

# SEGA

# VIRTUAL COP 2

DELUXE TYPE

## OWNER'S MANUAL

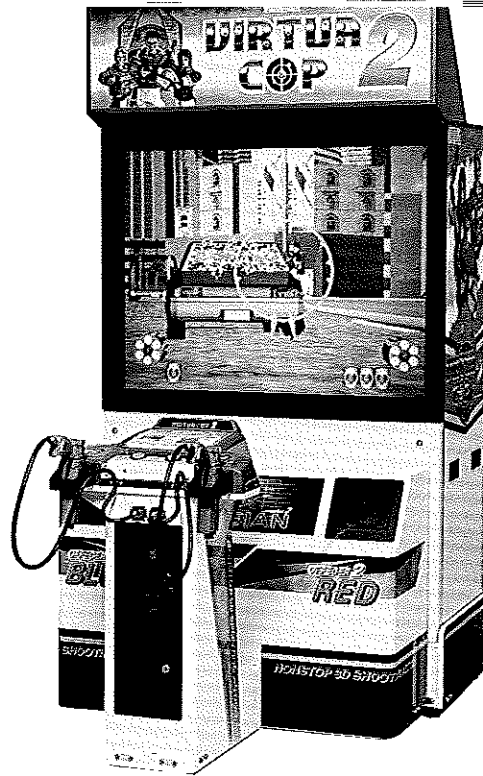

- Before using this product, be sure to read this manual.
- As far as you are using this product, keep this manual available.

## SEGA ENTERPRISES, LTD.

MANUAL NO. 420 - 6195 - 02



# BEFORE USING THE PRODUCT, BE SURE TO READ THE FOLLOWING:

To ensure the safe usage of the product, be sure to read the following before using the product. The following instructions are intended for the owners, operators and the personnel in charge of the operation of the product. After carefully reading and sufficiently understanding the instructions, handle the product appropriately.

Herein, explanations which require special attention are enclosed with dual lines. Depending on the potentially hazardous degrees, terms of WARNING!, CAUTION! and IMPORTANT! are used. SEGA is not liable whatsoever, even during the Liability period, for any injury or damage caused by the usage in the manner counter to the instructions herein stated. In order to prevent accidents, warning stickers and printed instructions are applied to the places where a potentially hazardous situation relating to the product can occur. For safety cause, be sure to comply with such warnings.



WARNING!

Indicates that mishandling the product by disregarding this warning will cause a potentially hazardous situation which can result in death or serious injury.



CAUTION!

Indicates that mishandling the product by disregarding this caution will cause a potentially hazardous situation which can result in personal injury and or material damage.



IMPORTANT!

This is cautionary information which should be complied with when handling the product. Indicates that mishandling the product by disregarding this will cause a potentially hazardous situation which might not result in personal injury but can damage the equipment, etc.

○ **Be sure to turn off power before working on the machine.**

To prevent electric shock, be sure to turn off power before starting the work in which the worker touches the interior of the product. If the work is to be performed in the power-on status, the Instruction Manual herein always states to that effect.

○ **Be sure to ground the Earth Terminal (this, however, is not required in the case where a power cord with earth is used).**

This product is equipped with the Earth Terminal. When installing the product, Connect the Earth Terminal to the "accurately grounded indoor earth terminal" by using an earth wire. Unless the product is grounded appropriately, the user can be subject to electric shock. After performing repair, etc. for the Control equipment, be sure to firmly connect the Earth Wire to the Control equipment.

○ **Ensure that the Power Supply used is equipped with a Circuit Protector.**

This product does not incorporate the Circuit Protector. Using a power supply which is not equipped with the Circuit Protector can cause a fire when short circuit occurs.

○ **Be sure to use fuses which meet the specified rating.**

○ **Specification changes (removal of equipment, conversion and addition) not designated by SEGA are not allowed.**

The parts of the product include warning labels for safety, covers for personal protection, etc. It is very hazardous to operate the product by removing parts and or modifying the circuits. Should doors, lids and protective parts be damaged or lost, refrain from operating the product. SEGA is not liable whatsoever for any injury and or damage caused by Specification changes (using other firm's parts, or by conversion) not designated by SEGA.

○ **Ensure that the product is of appropriate Electrical Specifications.**

Before installing the product, check for Electrical Specifications. SEGA products have a name-plate on which Electrical Specifications are described. Ensure that the product is compatible with the power supply voltage and frequency requirements of the location.

○ **Install and operate the product in places where appropriate lighting is available, allowing warning labels to be clearly read.**

To ensure safety for the customers, labels and printed instructions describing potentially hazardous situation are applied to places where accidents can be caused. Ensure that where the product is operated has sufficient lighting allowing the warnings to be read. If any label is peeled off, apply it again immediately.

○ **When handling the Monitor, be very careful. (Applies only to the product w/ monitor).**

Some of the monitor (TV) parts are subject to high tension voltage. Even after turning off power, some portions are still subject to high tension voltage sometimes. Monitor repair and replacement should be performed only by those technical personnel who have knowledge of electricity and technical expertise.

In the case where commercially available monitors and printers are used in this product, only the contents relating to this product are explained herein. Some commercially available equipment has functions and reactions not stated in this manual. Read this manual together with the specific Instruction Manual of such equipment.

- Descriptions herein contained may be subject to improvement changes without notice.
- The contents described herein are fully prepared with due care. However, should any question arise or errors be found, please contact SEGA.

## **INSPECTIONS IMMEDIATELY AFTER TRANSPORTING THE PRODUCT TO THE LOCATION.**

Normally, at the time of shipment, SEGA products are in a status allowing for usage immediately after transporting to the location. Nevertheless, an irregular situation may occur during transportation. Before turning on power, check the following points to ensure that the product has been transported in a satisfactory status.

- Are there any dented portions or defects (cuts, etc.) on the external surfaces of the cabinet?
- Are Casters and Leg Adjusters damaged?
- Do the power supply voltage and frequency requirements meet with those of the location?
- Are all wiring connectors correctly and securely connected? Unless connected in the correct direction, connector connections can not be made accurately. Do not insert connectors forcibly.
- Are all IC's of each IC BD firmly inserted?
- Do power cords have cuts and dents?
- Do the fuses used meet specified rating? Is the Circuit Protector in an energized status?
- Are such units as Monitors, Control equipment, IC BD, etc. firmly secured? Are all Earth Wires connected?
- Are all accessories available?
- Can all Doors and Lids be opened with the Accessory keys? Can Doors and Lids be firmly closed?

---

---

TABLE OF CONTENTS

---

---

INTRODUCTION OF THE OWNER'S MANUAL	
1. HANDLING PRECAUTIONS .....	1 ~ 2
2. PREVENTION OF COUNTERFEITING AND CONVERSION ...	3
3. PRECAUTIONS CONCERNING INSTALLATION LOCATION ..	4
4. NAME OF PARTS .....	5
5. ACCESSORIES .....	6
6. PRECAUTIONS TO BE HEEDED WHEN ASSEMBLING AND MOVING THE MACHINE .....	7 ~15
7. HOW TO PLAY .....	16~18
8. EXPLANATION OF TEST AND DATA DISPLAY .....	19~33
8-1 SW UNIT .....	20
8-2 TEST MENU .....	20
8-3 MEMORY TEST .....	21
8-4 T.G.P. TEST .....	21
8-5 INPUT TEST .....	22
8-6 OUTPUT TEST .....	22
8-7 SOUND TEST .....	23
8-8 C.R.T. TEST .....	23
8-9 GAME ASSIGNMENTS .....	24
8-10 COIN ASSIGNMENTS .....	25~28
8-11 GUN SETTING .....	29~31
8-12 BOOKKEEPING .....	32
8-13 BACKUP RAM CLEAR .....	33
9. CONTROLLER (GUN) .....	34~35
9-1 REPLACING THE MICROSWITCH .....	34
9-2 REPLACING THE SENSOR BOARD .....	35
10. COIN SELECTOR .....	36
11. ADJUSTING THE PROJECTOR .....	37~42
11-1 CLEANING THE SCREEN .....	37
11-2 ADJUSTING THE HITACHI PROJECTOR .....	38~40
11-3 ADJUSTING THE MITSUBISHI PROJECTOR .....	41~42
12. REPLACEMENT OF FLUORESCENT LAMP AND LAMPS .....	43
12-1 FLUORESCENT LAMP REPLACEMENT .....	43
12-2 LAMP REPLACEMENT .....	43
13. PERIODIC CHECK .....	44
14. TROUBLESHOOTING .....	44~45
15. GAME BOARD .....	46~47
15-1 REMOVING THE GAME BOARD .....	46
15-2 COMPOSITION OF GAME BOARD .....	47
16. DESIGN RELATED PARTS .....	48
17. PARTS LIST .....	49~78
18. WIRE COLOR CODE TABLE .....	80
19. WIRING DIAGRAM .....	81~82

---

---

## SPECIFICATIONS

Installation space	: 1,195 mm (W) × 1,690 mm (D) (47.0 in. × 66.5 in.)
Height	: 2,249 mm (88.5 in.)
Weight	: Approx. 241 kg. (531 lbs.)
Power, maximum current	: 400W 5.0A (AC 110V 50 Hz AREA) 390W 5.0A (AC 110V 60 Hz AREA) 400W 4.6A (AC 120V 60 Hz AREA) 410W 2.5A (AC 220V 50 Hz AREA) 410W 2.5A (AC 220V 60 Hz AREA) 410W 2.3A (AC 240V 50 Hz AREA) 400W 2.2A (AC 240V 60 Hz AREA)
For TAIWAN (HITACHI PROJECTION DISPLAY TYPE)	
Power, current	: 395W 4.95A (MAX.) 320W 3.90A (MIN.)
For TAIWAN (MITSUBISHI PROJECTION DISPLAY TYPE)	
Power, current	: 375W 4.75A (MAX.) 325W 3.90A (MIN.)
MONITOR	: 50 INCH PROJECTION DISPLAY

NOTE: Descriptions in this manual are subject to change without prior notice.

## INTRODUCTION OF THE OWNER'S MANUAL

SEGA ENTERPRISES, LTD., supported by its high electronic technology of LSIs, microprocessors, etc. and a wealth of experience, has for more than 30 years been supplying various innovative and popular game machines to the world market. This Owner's Manual is intended to provide detailed descriptions together with all the necessary information covering the general operation of electronic assemblies, electromechanicals, servicing control, spare parts, etc. as regards VIRTUA COP 2 DX TYPE, a new SEGA product.

This manual is intended for those who have knowledge of electricity and technical expertise especially in ICs, CRTs, microprocessors, etc. Carefully read this manual to acquire sufficient knowledge before working on the machine. Should there be a malfunction, non-technical personnel should under no circumstances touch the interior system. Should such a case arise, contact our Main Office or the closest branch office listed as follows:

SEGA ENTERPRISES, INC. (U.S.A.)/CUSTOMER SERVICE  
45133 Industrial Drive, Fremont, California 94538, U.S.A.  
Phone : (415) 802-3100  
Fax : (415) 802-1754

SEGA AMUSEMENTS EUROPE LIMITED/AMUSEMENT MACHINE SALES DIVISION  
Unit 2 Industrial Estate, Leigh Close, New Malden, Surrey KT3 3NL, England  
Phone : (081) 336-2256  
Fax : (081) 336-1715

SEGA SOUTHERN EUROPE LIAISON OFFICE  
Calle Vallellano, 19-23, 1° A, 37008-Salamanca, Spain  
Phone : (923) 265893  
Fax : (923) 265913

# 1. HANDLING PRECAUTIONS

When installing or inspecting the machine, be very careful of the following points and pay attention to ensure that the player can enjoy the game safely.

- Be sure to turn the power off before working on the machine.
- To insert or pull out the plug quickly is dangerous.
- It is necessary to make sure that the power cord or the grounding wire is not exposed on the surface (floor, ground, etc.) in a manner so as to be dangerous. Make sure that grounding connections are made safely at the position where so specified.
- Do not use any fuse that does not meet specified rating.
- Make complete connections for the IC board and other connectors. Insufficient insertion is very dangerous.
- The operating (ambient) temperature range is from 5°C to 40°C.

Also, for the IC board circuit inspections, only the logic tester is allowed. The use of a tester is not permitted, so be careful in this regard. After confirming that there are no irregularities, turn the power ON.



When the controller is pointed outside the screen, it sometimes (though rarely) functions the same as when shooting inside the screen. This is caused by some other machine's on-screen light or fluorescent light, etc. reflected on the controller. Should such a phenomenon occur frequently, change the position and or direction of this unit or objects causing the problem.

## CONCERNING THE PROJECTION DISPLAY:

A PROJECTION DISPLAY is used for this machine. The PROJECTION DISPLAY's screen is susceptible to damage and therefore, when cleaning it, pay careful attention. For details, refer to Section 11.

## CONCERNING THE STICKER DISPLAY

SEGA product has Stickers describing the product manufacture No. (Serial No.) and Electrical Specifications. Also it has a Sticker describing where to contact for repair and for purchasing parts.

When inquiring about or asking for repair, mention the Serial No. and Name of Machine indicated on the Sticker. The Serial No. indicates the product register. Identical machines could have different parts depending on the date of production. Also, improvements and modifications might have been made after the publication of this Manual. In order to meet the above situations, mention the Serial No. when contacting the applicable places.

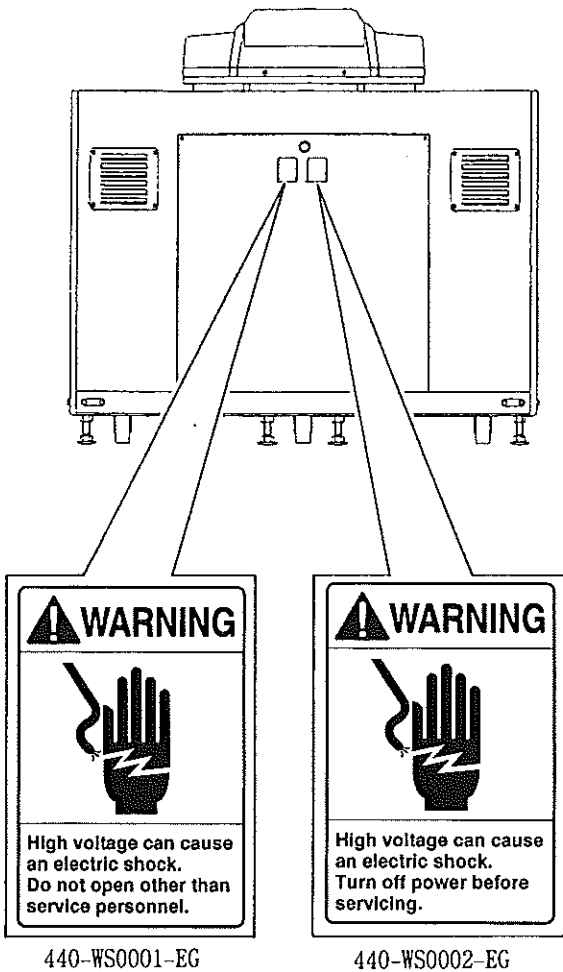

## CONCERNING WARNING DISPLAYS

SEGA product has warning displays on Stickers, Labels and or printed instructions adhered / attached to or incorporated in the places where a potentially hazardous situation can arise. The warning displays are intended for avoiding hazardous situation relating to maintenance and servicing work, and for the prevention of accidents for the customers.

There are some portions in the Cabinet, which are subject to high tension voltage, etc. where accidents can be caused only by touching. When performing the servicing work, be very careful of the warning displays. Especially, repair and replacement work not mentioned herein, should be performed by those technical personnel who have knowledge of electricity and technical expertise.

For the prevention of accidents, caution any customer whose act runs counter to the warnings, as to the effect that he must stop the act.

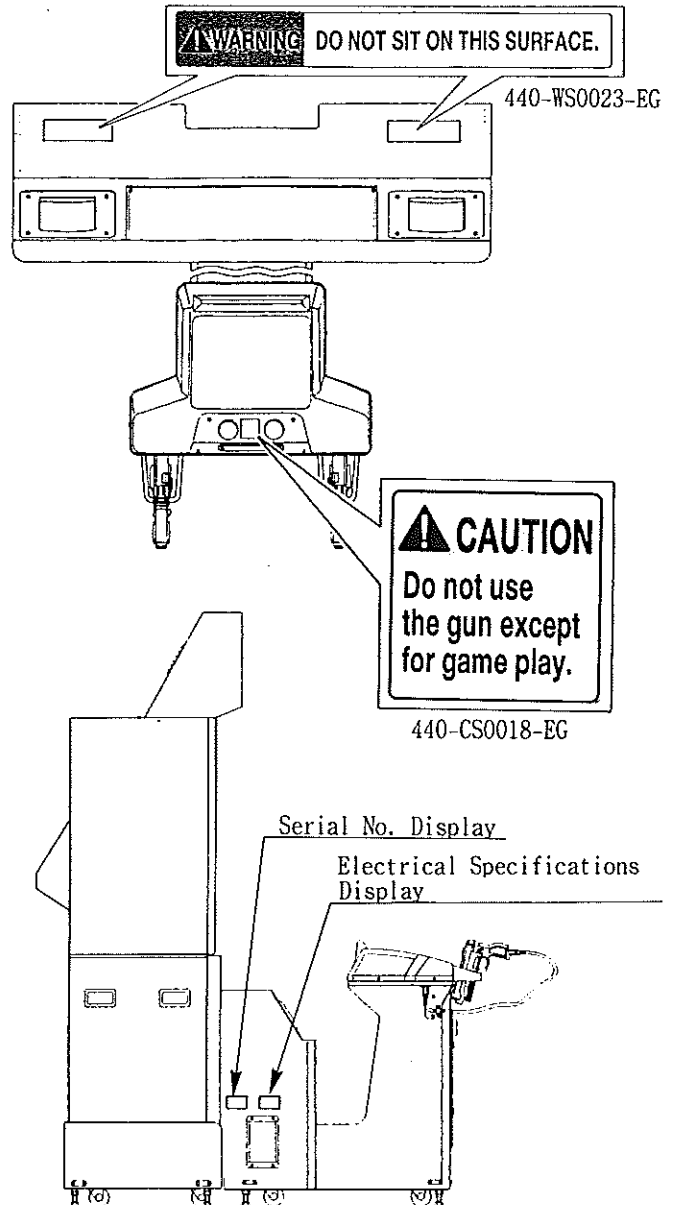



## 2. PREVENTION OF COUNTERFEITING AND CONVERSION

### ▶ LABELLING ◀

To prevent counterfeits and conversions, the following labels are put on all the SEGA products. When handling such goods, be sure to confirm the labels. They are used to prevent illegal acts such as the unauthorized copying of the products and the printed circuit boards thereof or carrying on business by manufacturing similar merchandise or by converting, selling or using such products or printed circuit boards.

#### ORIGINAL SEAL

The following seal is put on the machines manufactured by SEGA.



### ▶ COPYRIGHT NOTICE ◀

This SEGA product has the copyright notice as follows:

© SEGA 1995

This signifies that this work was disclosed in 1995 and is the property of SEGA ENTERPRISES, LTD.

### 3. PRECAUTIONS CONCERNING INSTALLATION LOCATION

The **VIRTUA COP 2 DX TYPE** is an indoor game machine. Under no circumstances install it outside. Even indoors, avoid installing in places mentioned below so as to ensure proper usage:

- Places subject to rain or water leakage, or condensation due to humidity.
- In the proximity of an indoor swimming pool and/or shower.
- Places subject to direct sunlight.
- Places subject to heat sources from heating units, etc., or hot air.
- Vicinity of highly inflammable/volatile chemicals or hazardous matter.
- Sloped surfaces.
- Vicinity of anti-disaster facilities such as fire exits and fire extinguishers.
- Places subject to any type of violent impact.
- Dusty places.

#### INSTALLATION PRECAUTIONS

- Do not insert more than one electrical plug into the power plug socket which is equipped with a Circuit Protector. This product does not incorporate the Circuit Protector. Be sure to prepare it to prevent outbreak of fire caused by generation of heat when short circuit occurs.
- The location facility need to have the Circuit Breaker and Earth Mechanism for this product.
- The per unit standard voltage/ampereage is 100~120V/5A and 200~240V/3.5A.
- Use of extension cables should be avoided. If you must use, ensure the extension cables are rated at 7A or higher for 100~120 volt areas or 3.5A or higher for 200~240 volt areas.
- Note that for transporting the machine into the location's building, the minimum necessary dimensions of the opening (of doors, etc.) are 0.9 m (W) and 1.2 m (H).
- For the operation of this machine, secure a minimum area of 1.2 m (W)×2.2 m (D).

#### Electric current consumption

MAX. 5.0A (AC 110V 50 Hz)
MAX. 5.0A (AC 110V 60 Hz)
MAX. 4.6A (AC 120V 60 Hz)
MAX. 2.5A (AC 220V 50 Hz)
MAX. 2.5A (AC 220V 60 Hz)
MAX. 2.3A (AC 240V 50 Hz)
MAX. 2.2A (AC 240V 60 Hz)
MAX. 4.95A (For TAIWAN, HITACHI projection display)
MAX. 4.75A (For TAIWAN, MITSUBISHI projection display)

## 4. NAME OF PARTS

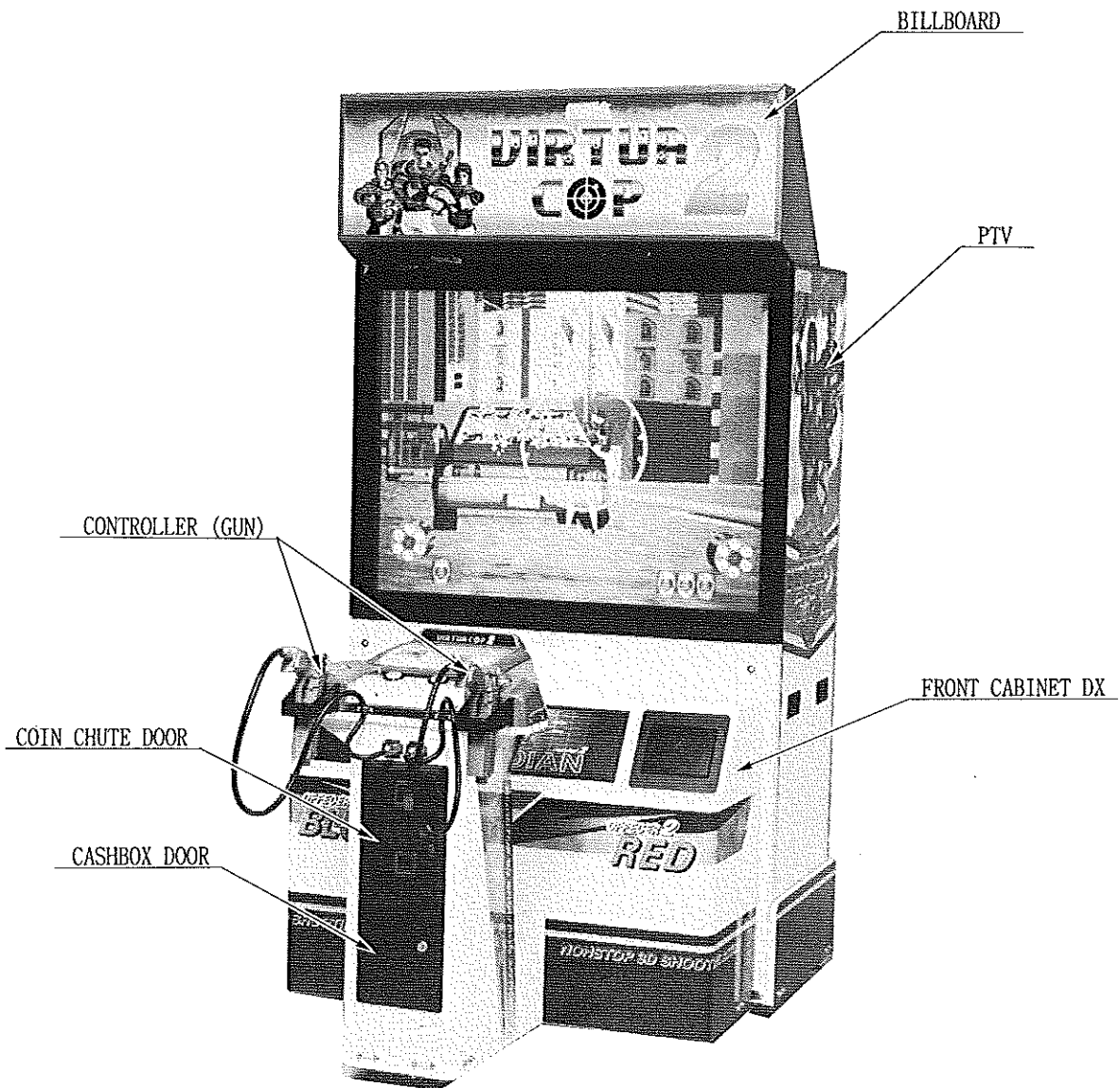

FIG. 4 OVERVIEW

TABLE 4

	Width	Length	Height (mm.)	Weight (kg.)
FRONT CABINET DX	1,095 ×	987 ×	992	Approx. 80
PTV w/PTV BASE	1,195 ×	782 ×	2,249	Approx. 161
When assembled	1,195 ×	1,690 ×	2,249	Approx. 300

## 5. ACCESSORIES

When transporting the machine, make sure that the following parts are supplied.

TABLE 5 ACCESSORIES

Part No.	Qty.	DESCRIPTION	Note
220-5381	2	KEY MASTER FOR 220-5380	For opening/closing the doors
	2	KEY	For the CASHBOX DOOR
420-6195-02	1	OWNERS MANUAL VIRTUA COP 2 DX ENG	
540-0006-01	1	WRENCH FOR TAMP PRF SCR DUAL TYPE M4	Tool
600-6664-02	1	EARTH WIRE	Used for installation. See Sec. 6.
509-5080	1	SW MICRO TYPE	For spare, See Sec. 9
390-5160	1	LAMP 6V 3W	For spare, See Sec. 12.
200-5297	1	REMOTE CONTROLLER H (HITACHI)	Used for adjustment. See Sec. 11.
200-5410			
200-5298		REMOTE CONTROLLER M (MITSUBISHI)	

TOOL

(TAMPERPROOF WRENCH)  
M4 540-0006-01

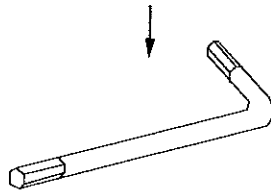

FIG. 5 TAMPERPROOF WRENCH

## 6. PRECAUTIONS TO BE HEEDED WHEN ASSEMBLING AND MOVING THE MACHINE



- Perform the assembly work by following the procedure herein stated. Failing to comply with the instructions, for example, inserting the plug into an outlet at the stage not mentioned in this manual can cause an electric shock accident.
- Assembling should be performed as per this manual. Since this is a complex machine, erroneous assembling can cause damage to the machine or malfunctioning to occur.
- When assembling, be sure to perform the work by plural persons. Depending on the assembly work, there are some cases in which performing the work by a single person can cause personal injury or parts damage.

When carrying out the assembly work, follow the procedure in the following 5-item sequence:

- 1 ASSEMBLING THE PTV
- 2 CONNECTING THE FRONT CABINET DX AND PTV
- 3 POWER SUPPLY, AND EARTH CONNECTION
- 4 SECURING IN PLACE (LEG ADJUSTER ADJUSTMENT)
- 5 ASSEMBLY CHECK

Note that the tools such as a plus screwdriver and wrench for M16 hexagon bolt w/24 mm width across flats are required for the assembly work.

# 1 ASSEMBLING THE PTV



When performing ⑤, ⑥ and ⑦ below, it is difficult to carry out the work by one person. Be sure to perform the work by plural persons.

- ① By using the specified screws, secure the 2 Mask Holders to the Projection Display ceiling. (FIG. 6.1)
- ② Insert the TV Mask from the underside as shown and secure with a total of 6 screws.
- ③ Secure Panel Mount Bracket L and R to the front of Projection Display in the installation direction shown with 2 screws for each.
- ④ Secure the Front Panel to both Panel Mount Brackets with a total of 4 screws.
- ⑤ Insert the Billboard Connector into the Terminal Board of Projection Display ceiling.
- ⑥ Insert the Billboard from the front as shown and secure with 2 screws. (FIG. 6.1)
- ⑦ Mount the assembled PTV on the PTV Base.

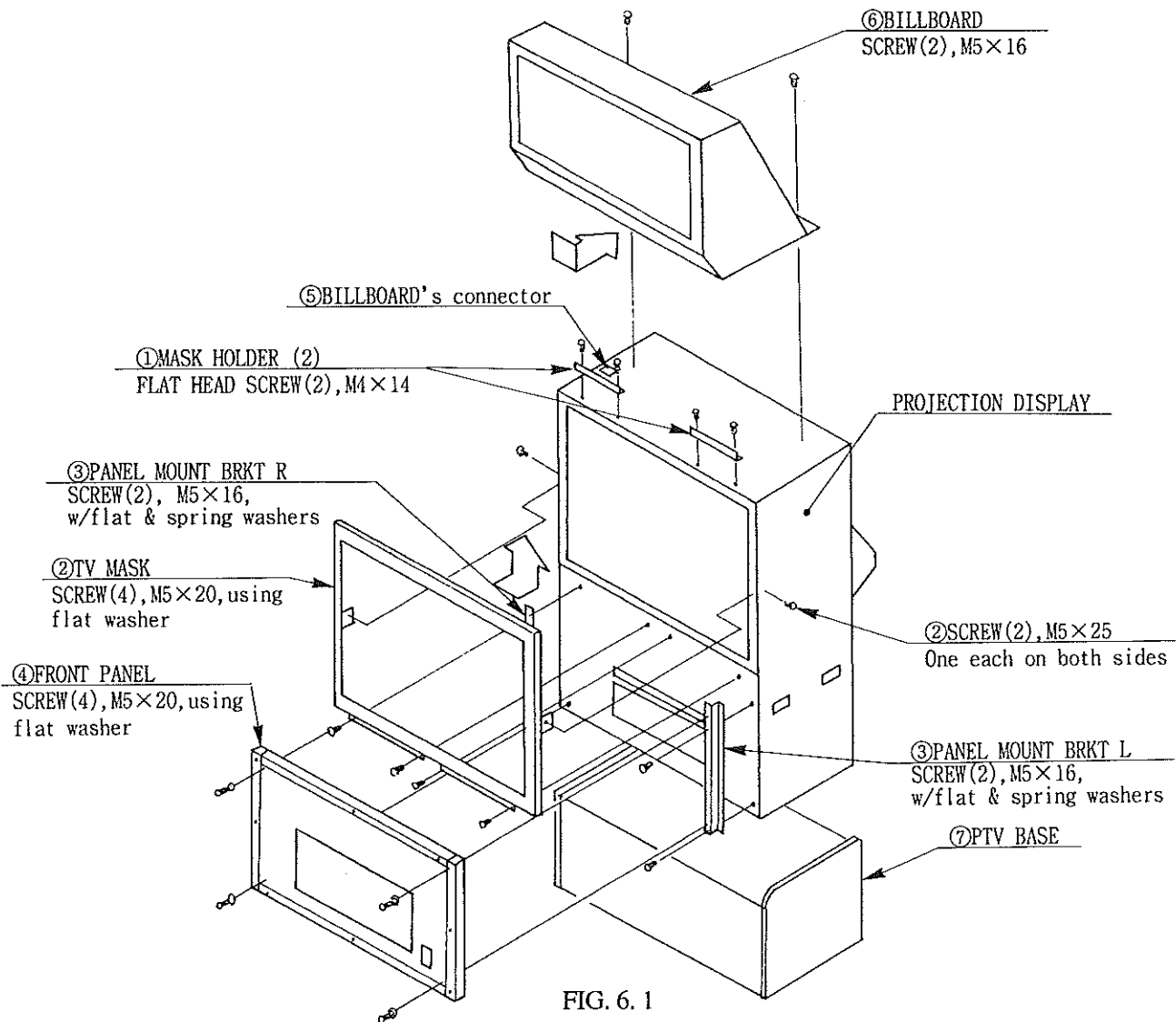

## 2

### CONNECTING THE FRONT CABINET DX AND PTV

Install the CONNECT TUBE in between PTV & FRONT CABINET DX and connect the wire. When performing the work, be sure to pay careful attention so that the CONNECT TUBE wiring will not be damaged by catching in between the door and the cabinet.

- ① Remove the PTV's SERVICE DOOR and FRONT CABINET DX BACK LID.

- ② Put the CONNECT TUBE's wiring connectors in the square hole beside the SERVICE DOOR and secure the JOINT BOX with 4 truss screws by paying careful attention that the connectors are not damaged.

- ③ Connect the CONNECT TUBE's wiring connectors to the connector panel inside the PTV. At this time, make sure that the wire color (red, green, blue and the remaining color) corresponds with the applicable symbol of the connector panel's display (R. G. B. and SYNC terminals). (FIG. 6. 2 a)

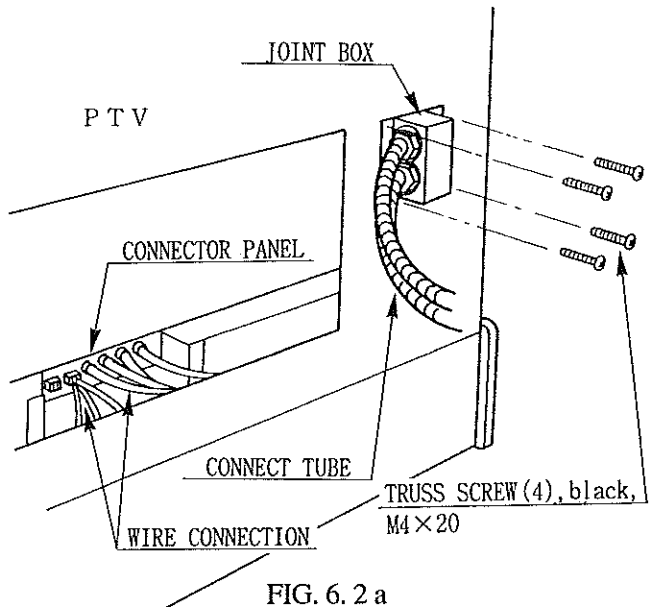

FIG. 6. 2 a

Also, note that the connector's insertion angle is predetermined. When the connector is forcibly inserted in an incorrect direction, it can be damaged. Therefore, ascertain the correct direction before insertion. After insertion, turn the connector ring clockwise to lock the connection.

- ④ Put the connect tube wires into the square hole of the FRONT CABINET DX and secure the joint box with 4 truss screws. When fastening the screws, be careful so that the wires are not damaged. (FIG. 6. 2 b)

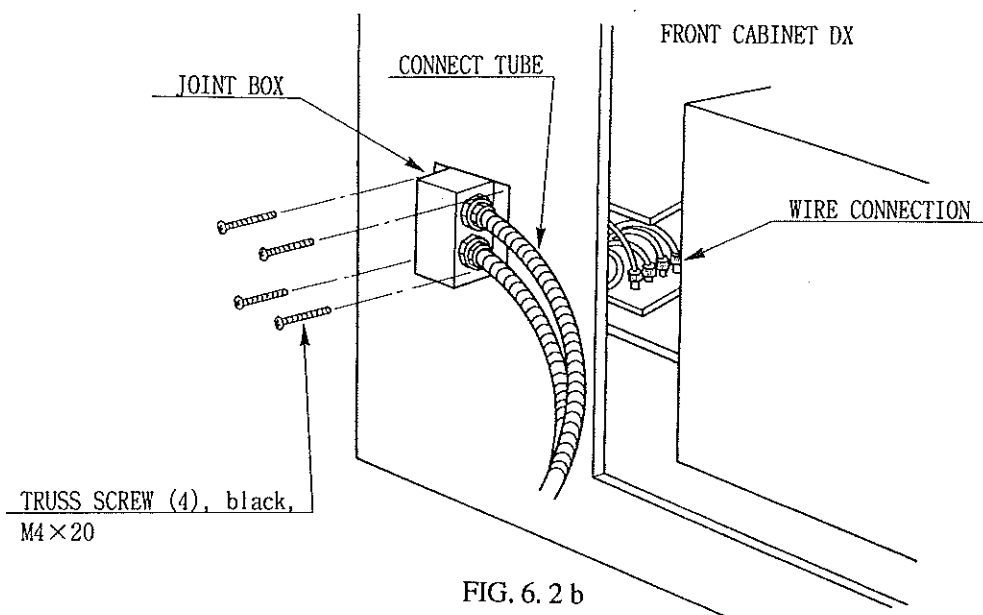

FIG. 6. 2 b

- ⑤ Connect the CONNECT TUBE's wire with VPM buffer BD & 3P white connector inside the FRONT CABINET DX. Make sure that the connector color corresponds to the applicable one of on-Board R. G. B. Insert the remaining color wire into SYNC. As for the 4 connectors inserted on the board, turn the connector ring clockwise to lock the connection.
- ⑥ Install the PTV's SERVICE DOOR.
- ⑦ Install the BACK LID to the FRONT CABINET DX with the 2 screws.

### JOINING METHOD

- ① Loosen the 2 Hexagon Bolts, one each on both sides of Front Cabinet DX.
- ② Loosen the 2 Hexagon Bolts, one each on both sides of of the PTV.
- ③ Install Joint Bracket L and R by fastening with the previously loosened Hexagon Bolts.



IMPORTANT!

When joining, be careful not to damage the Wire Tube which connects Front Cabinet DX and PTV. The Joint Bracket is used for protecting the PTV from falling down.

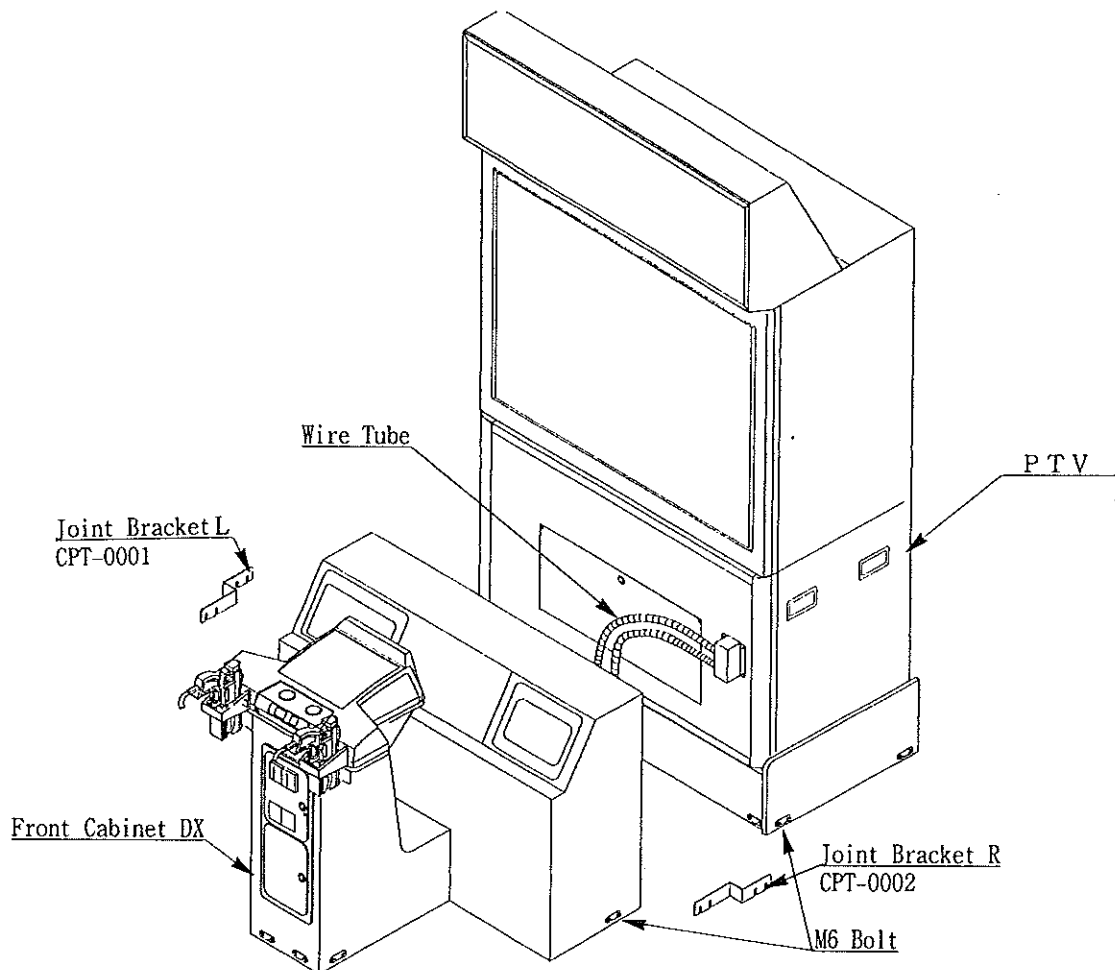

FIG. 6.2 c



### 3 SECURING IN PLACE (LEG ADJUSTER ADJUSTMENT)



Make sure that all of the leg adjusters are in contact with the floor. If they are not, the cabinet may move and cause an accident.

This machine has 4 each of casters and leg adjusters on PTV Base, and 4 Leg Adjusters & 3 Casters for Front Cabinet DX (FIG. 6. 3 a). When the installation position is determined, cause the leg adjusters to come into contact with the floor directly, make adjustments in a manner so that the casters will be raised approximately 5mm. from the floor and make sure that the machine position is level.

- ① Move the machine to the installation position.
- ② Cause all of the leg adjusters to make contact with the floor. By using a wrench, make adjustments in the height of the leg adjusters to ensure that the machine's position is level.
- ③ After making adjustments, fasten the leg adjuster nut upward and secure the height of the leg adjuster.

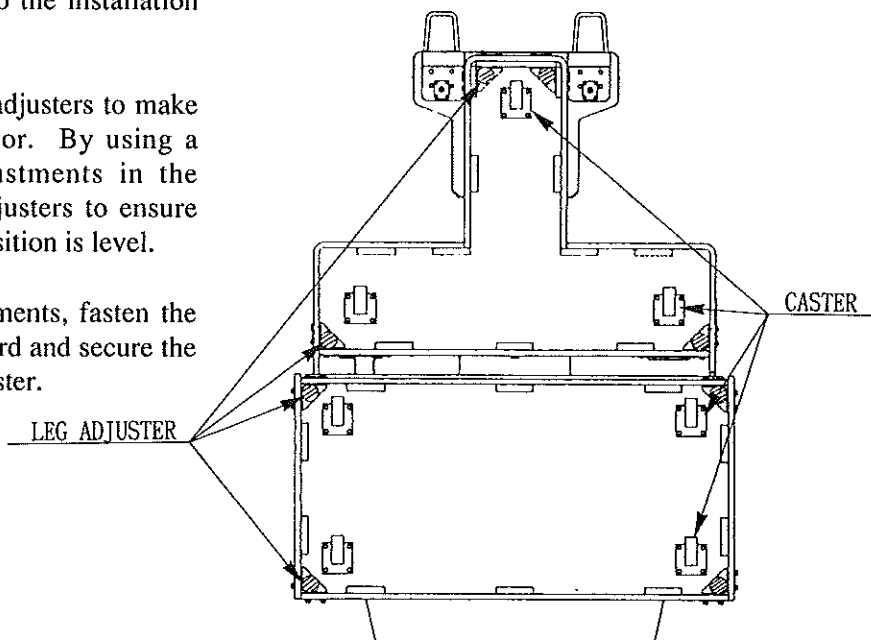

FIG. 6. 3 a BOTTOM VIEW

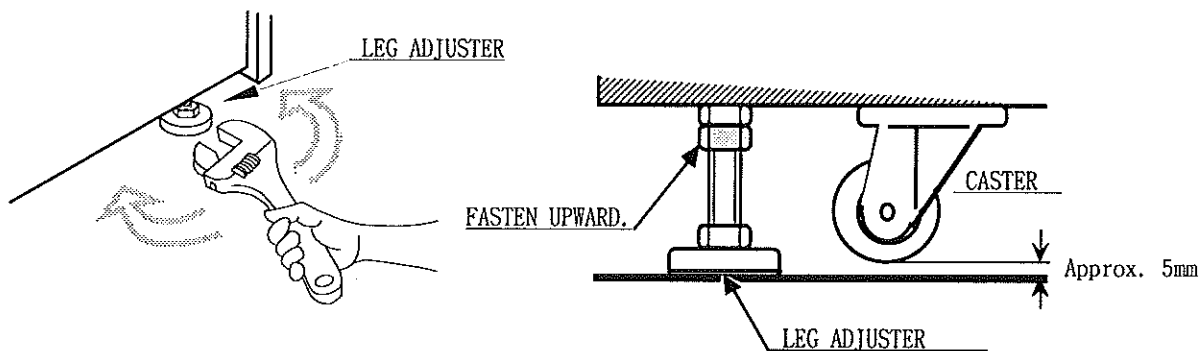

FIG. 6. 3 b LEG ADJUSTER

## 4

## POWER SUPPLY, AND EARTH CONNECTION



## WARNING!

- Ensure that the power supply is equipped with a Circuit Protector. Using the power supply which is not equipped with the Circuit Protector can cause a fire resulting from a short circuit.
- Ensure that the "accurately grounded indoor earth terminal" is available. This product is equipped with the earth terminal. Connect the earth terminal and the indoor earth terminal with an Earth Wire. If the grounding work is not performed appropriately, customers can be subjected to an electric shock, and the product's functioning may not be stable.
- Ensure that the power cord and earth wire are not exposed. If exposed, they are susceptible to damage, being caught by customers. If damaged, they can cause an electric shock or short circuit. Ensure that the cord and earth wire are not in the customer's passage way, or ensure that a protective covering is installed.

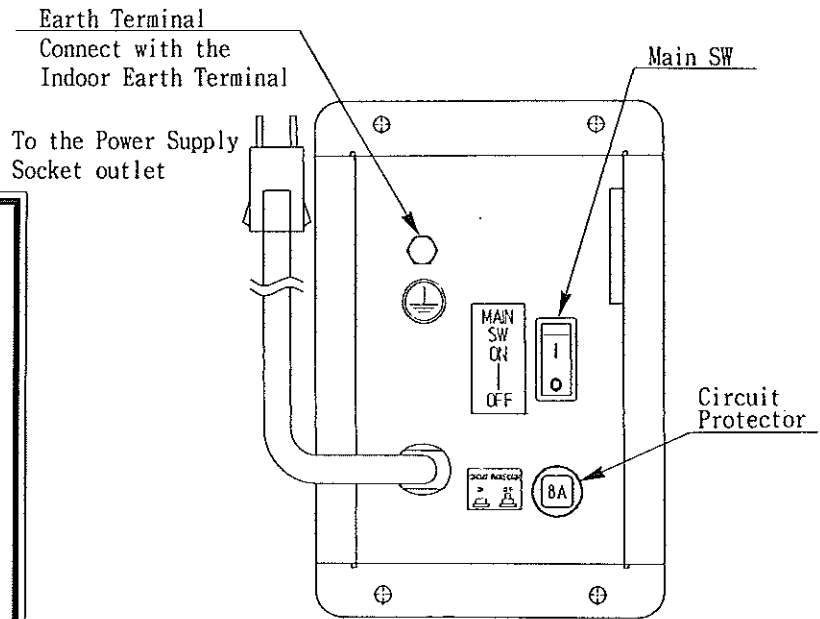

FIG. 6. 4 a AC Unit

- ① The AC unit is mounted on the rear of Cabinet DX. The AC Unit incorporates the Main SW, power cord, and earth terminal.
- ② Ensure that the Main SW is OFF.
- ③ Connect one end of the Earth Wire to the AC Unit's Earth Terminal and the opposite end to the Indoor Earth Terminal. The AC Unit's Earth Terminal has a Bolt and Nut combination. Take off the Nut and pass the Earth Wire end to the Bolt portion and fasten the Nut part.

Connect the Earth Wire to the Earth Terminal

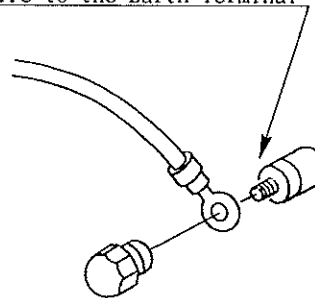

FIG. 6. 4 b Earth Wire Connection

- ④ Firmly insert the Power Plug into the Socket Outlet.
- ⑤ Perform wiring for the Power Cord and Earth Wire. Install Wire Covering to protect the Power Cord and Earth Wire.
- ⑥ Turn the Main Switch ON to turn power ON.

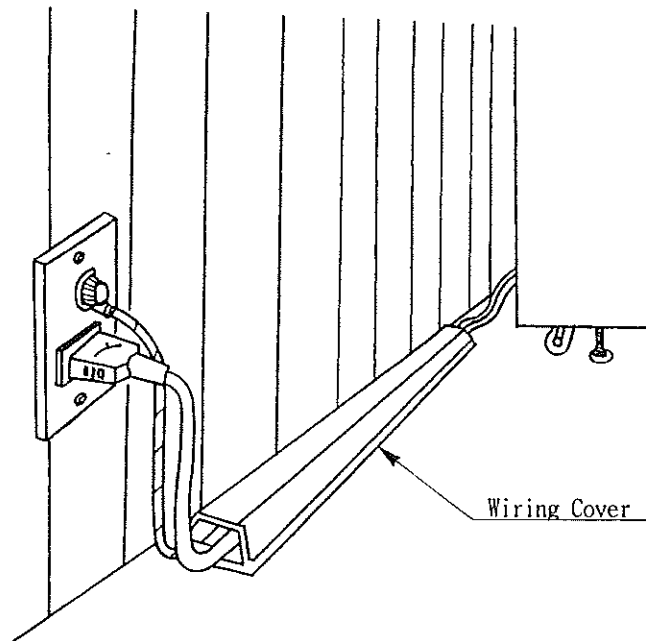

FIG. 6. 4 c Wiring for Power Cord and Earth Wire

## 5 ASSEMBLY CHECK

In the TEST MODE, ensure that the assembly has been made correctly and IC BD. is satisfactory (refer to Section 8).  
 In the test mode, perform the following test:

```

ROM
IC. 4 GOOD
IC. 7 GOOD
IC. 10 GOOD
IC. 13 GOOD

MEMORY TEST
IC. 5 GOOD
IC. 8 GOOD
IC. 11 GOOD
IC. 14 GOOD

IC. 6 GOOD
IC. 9 GOOD
IC. 12 GOOD
IC. 15 GOOD

RAM
IC. 45 GOOD
IC. 48 GOOD
IC. 54 GOOD

IC. 46 GOOD
IC. 49 GOOD
IC. 55 GOOD

IC. 47 GOOD
IC. 50 GOOD

TEST : TO EXIT
  
```

Selecting the MEMORY TEST on the test mode menu screen causes the on-board memory to be tested automatically. The game board is satisfactory if the display beside each IC No. shows GOOD.

```

INPUT TEST
CHUTE #1 OFF CHUTE #2 OFF
START1 OFF START2 OFF
TEST-SW OFF SERVICE-SW OFF
TRIGGER1 OFF TRIGGER2 OFF

TEST & SERVICE : TO EXIT
  
```

Selecting the INPUT TEST on the test mode menu screen causes the screen (on which each switch is tested) to be displayed. Press each switch. For the coin switch test, insert a coin from the coin inlet with the coin chute door being open. If the display beside each switch indicates "ON," the switch and wiring connections are satisfactory.

```

OUTPUT TEST

LAMP

→ EXIT

SELECT WITH SERVICE BUTTON
AND PRESS TEST BUTTON
  
```

Select "OUTPUT TEST" from the Test Menu in the Test Mode to have the Lamp Test Screen displayed. Check if each lamp lights up satisfactorily.

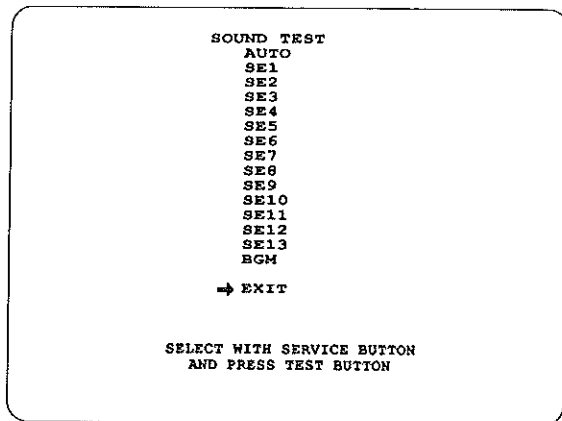

In the TEST mode, selecting SOUND TEST causes the screen, on which sound related BD and wiring connections are tested, to be displayed. Be sure to check if the sound is satisfactorily emitted from each speaker and the sound volume is appropriate.

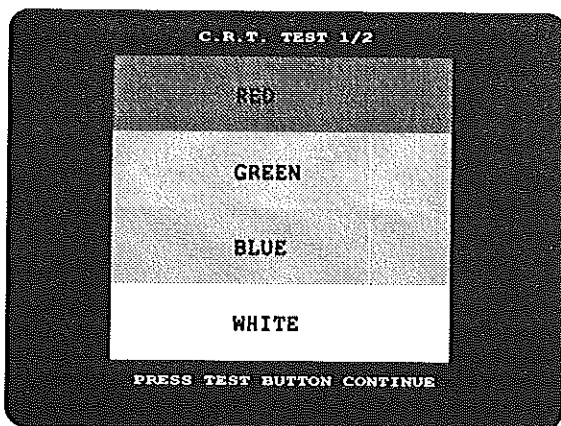

In the TEST mode menu, selecting C.R.T. TEST allows the screen (on which the projector is tested) to be displayed. Although the projector adjustments have been made at the time of shipment from the factory, color deviation, etc., may occur due to the effect caused by geomagnetism, the location building's steel frames and other game machines in the periphery. By watching the test mode screen, make judgment as to whether an adjustment is needed. If it is necessary, adjust the projector by referring to Section 11.

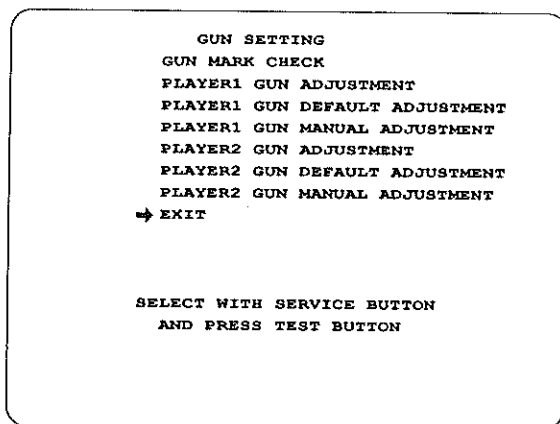

On the menu screen in the test mode, selecting GUN SETTING displays the screen on which gun sighting is set. Check to see if there is any problem for playing game.

Perform the above inspections also at the time of monthly inspection.

#### CAUTIONS TO BE HEEDED WHEN MOVING THE MACHINE



IMPORTANT!

- When moving the machine, be sure to remove the Joint Bracket L and R which secure the Front Cabinet DX and PTV Base. Moving the machine with the Brackets as is installed can damage parts.
- Front Cabinet DX weighs approximately 80 kg., and the PTV, approximately 160 kg. When moving the machine on the floor, Leg Adjusters should be retracted to have the Casters come into contact with the floor.
- When moving Front Cabinet DX, inclining it diagonally can cause the Controller (Gun) to fall off and to be damaged. Be very careful in this regard.
- If the floor has step like differences, be sure to separate the PTV and PTV Base when moving them. Inclining the PTV with the base as is installed can cause the PTV to fall down from the Base.

# 7. HOW TO PLAY

## CONTENT OF GAME AND HOW TO PLAY

- ① Inserting a coin(s) causes the credit display on the bottom of the screen to count. Inserting one credit worth coin(s) changes the message on the bottom of the screen from "INSERT COIN(S)" to "PUSH START" and both of the start buttons light up. The maximum number of credits counted at a time is 9. Any coin inserted after counting 9 credits will not be counted as any credits, nor be returnable. These coins, however, will count as coins inserted in bookkeeping and the coin meter. Note that game setting to USA allows up to 24 credits to be counted.
- ② Pressing either of the start buttons determines which side (left or right) you are playing on. There are 3 Stages available, i. e., File 1 BEGINNER, File 2 MEDIUM and File 3 EXPERT. Shoot to select the desired stage. If no desired stage is selected, BEGINNER will be chosen automatically to start.

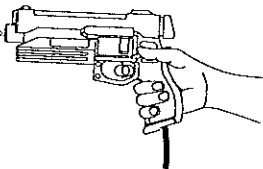
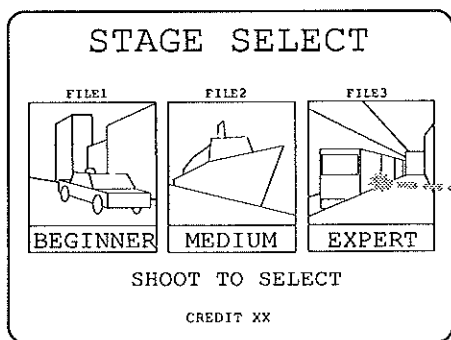

Shoot to select the desired stage.

- ③ When the game starts, the player's mission and boss character are introduced.
  - The life points and the number of bullets of the left-hand side player (1P) are displayed on the lower left-hand side of the screen, and those of the right-hand side player (2P), on the lower right-hand side of the screen.
  - The LOCK-ON SIGHT indicates the enemy character who is firing at the player. If the sight turns red, the enemy fires at the player and he loses one life point.

If the sight turns red, the enemy fires at the player.

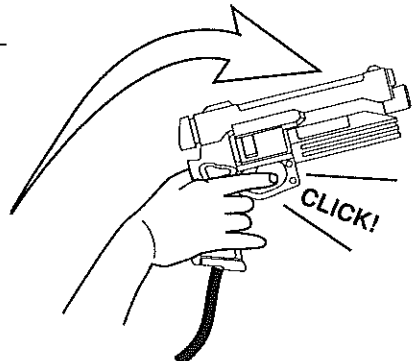
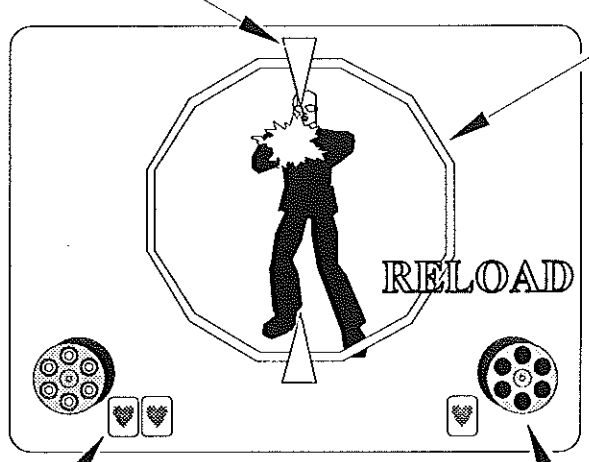

When your gun runs out of ammo, point outside the screen and pull the trigger to reload.

When the life point becomes zero, the game is over.

The loaded status of ammo is shown by cartridges in the cylinder.

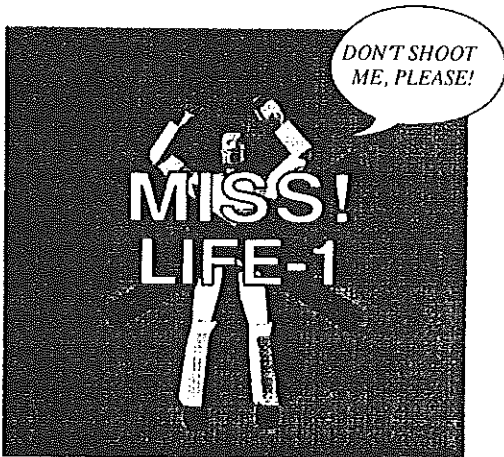

- The player loses one life point if he shoots a hostage by mistake.
  - The gun holds 6 bullets. When it runs out of ammo, "RELOAD" is displayed on the screen. At this time, point outside the screen and pull the trigger to reload.
  - The enemy's hand grenades, axes, rocket bombs, fire bombs, etc., can be shot down for your defense.
- 
- In the Stage, the player will notice the Signboard showing destinations. Shoot the Signboard to select the desired destination displayed by the signboard appearing on the screen. If the Signboard is not shot within a certain time period, the player proceeds in a certain direction automatically.
  - Shooting the background causes Special Items to appear. Capturing an item by shooting strengthens your weapon or recovers life points (explanations as regards the items are given later),
  - When the life point becomes zero, the game is over.
  - Downing the boss character awaiting you at the end of each stage results in clearing that particular stage. The player can not defeat the boss until his life meter becomes zero.
- 
- ④ Clearing all 3 Stages allows a short Special Stage (in which the Final Boss appears) to begin.
  - ⑤ If you would like to join in the game at anytime while the other person is playing, insert a coin(s) and press the start button. Also, when credits allowing the game to be played still remain, the start button on the other side will keep flashing. The player can participate in the game by pressing the flashing button.
  - ⑥ When the life point becomes zero, if you want to continue, insert a coin(s) required to continue and press the start button. If credits allowing the player to continue still remain, you can continue by merely pressing the start button.
  - ⑦ At the time of game over, if the player's score ranks 10th or higher, his name can be entered.

## CONCERNING SPECIAL ITEMS:

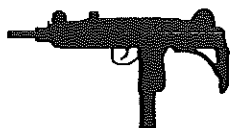

### MACHINE GUN

Holds 30 bullets. Can be repeatedly fired by keeping the trigger pulled. This can not be reloaded. Running out of ammo, or being damaged by the enemy causes the machine gun to become an ordinary gun.



### RIFLE

Holding 24 bullets, this allows for 3 consecutive shoots every time the trigger is pulled. It can not be reloaded. Running out of ammo, or being damaged by the enemy causes the rifle to become an ordinary gun.



### AUTOMATIC

Holding 15 bullets, this allows for reloading. When damaged by the enemy, this becomes an ordinary gun.



### SHOT GUN

Holds 6 bullets. Having a large "HIT" determining range, this allows you to shoot the enemy easier. It allows for reloading. When damaged by the enemy, it becomes an ordinary gun.



### MAGNUM GUN

Holds 6 bullets. Allows you to hit the enemy through an obstacle. Can be reloaded. When damaged by the enemy, it becomes an ordinary gun.



### LIFE

The life point increases by one, provided however that the life points in total do not exceed 10.

Depending on items, when a certain item is already strengthened, shooting another may cause such strengthened item to become another item.

## KNACK OF EARNING A HIGH SCORE:

### ● ACCURATELY SHOOT AT THE HEAD OR CHEST.

In each stage, enemy characters other than the boss can be downed by hitting any part of the body. When a bullet hits any portion other than the head or chest, a hit or not must be determined. Until such time that a hit or not is determined, shooting at the character that appears behind the opponent who was previously shot will result in shooting the previously shot character again instead. On the other hand, if any character is shot in the head or chest, he will be downed by single shot and in this case, there will be no need for hit determination, thus making it easy to shoot the enemy behind. The higher the stage level is, the more important the shooting accuracy becomes.

### ● FORESEEING THE ENEMY APPEARANCE POSITION

The enemy marked with the LOCK-ON SIGHT is the only one that fires at you. To forecast the enemy's appearance position, pay attention to the direction in which the sight moves. Since their appearance pattern is the same every time, you could master a knack of play by learning such pattern through repeated game play.



## 8. EXPLANATION OF TEST AND DATA DISPLAY

By operating the switch unit, periodically perform the tests and data check. When installing the machine initially or collecting cash, or when the machine does not function correctly, perform checking in accordance with the explanations given in this section. The following shows tests and modes that should be utilized as applicable.

TABLE 8 EXPLANATION OF TEST MODE

ITEMS	DESCRIPTION	REFERENCE SECTIONS
INSTALLATION OF MACHINE	When the machine is installed, perform the following: 1. Check to see that each setting is as per standard setting made at the time of shipment. 2. In the INPUT TEST mode, check each SW and VR. 3. In the OUTPUT TEST mode, check each of lamps. 4. In the MEMORY TEST mode, check ICs on the IC Board.	8 - 9, 8 - 10  8 - 5  8 - 6  8 - 3, 8 - 4
MEMORY	Choose MEMORY TEST in the MENU mode to allow the MEMORY test to be performed. In this test, PROGRAM RAMs, ROMs, and ICs on the IC Board are checked.	8 - 3, 8 - 4
PERIODIC SERVICING	Periodically perform the following: 1. MEMORY TEST 2. Ascertain each setting. 3. In the INPUT TEST mode, test the CONTROL device 4. In the OUTPUT TEST mode, check each of lamps.	8 - 3, 8 - 4  8 - 9, 8 - 10  8 - 5  8 - 6
CONTROL SYSTEM	1. In the INPUT TEST mode, check each SW and VR. 2. Adjust or replace each SW and VR. 3. If the problem can not be solved yet, check the CONTROL's moves.	8 - 5  9  9
PROJECTOR	In the PROJECTOR ADJUSTMENT mode, check to see if the PROJECTOR adjustment is appropriately made.	8 - 8
IC BOARD	1. MEMORY TEST 2. In the SOUND TEST mode, check the sound related ROMs.	8 - 3, 8 - 4  8 - 7
DATA CHECK	Check such data as game play time and histogram to adjust the difficulty level, etc..	8 - 12

## 8-1 SW UNIT

Open the coin chute door, and you will see the switch unit shown. The functioning of each SW is as follows:

- ① SOUND VOLUME ----- Controls the speaker volume.
- ② TEST BUTTON ----- For the handling of the TEST BUTTON, refer to the section on test mode.  
(TEST SW)
- ③ SERVICE BUTTON ----- Gives credits without registering on the coin meter.  
(SERVICE SW)

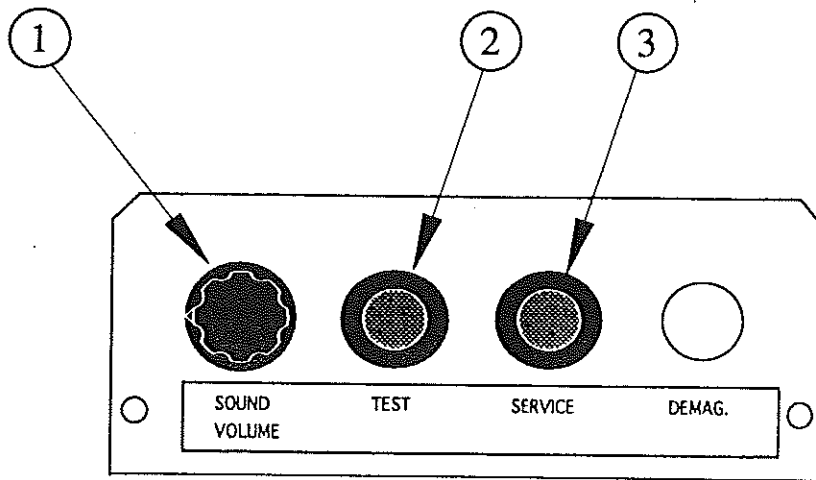
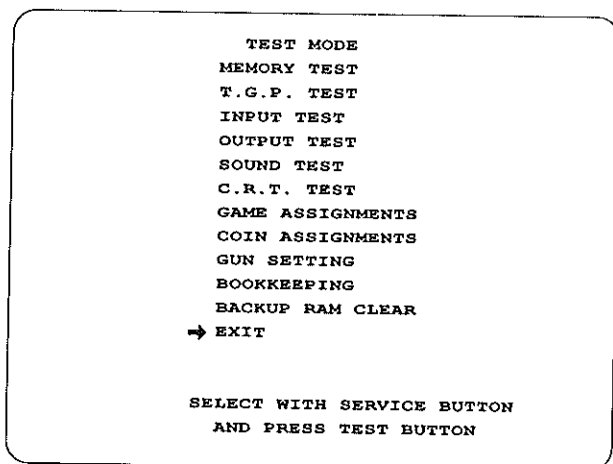

FIG. 8.1 SW UNIT

## 8-2 TEST MENU

This mainly checks if the operation of the game BD is accurate, and allows for COIN ASSIGNMENTS/GAME ASSIGNMENTS setting and Projector adjustments.

### SELECTION OF TEST ITEMS



- ① Push the TEST BUTTON to cause the following TEST MENU to appear:
- ② By pushing the SERVICE BUTTON, bring the arrow mark "→" to the desired item and press the TEST BUTTON.
- ③ After the test is complete, move "→" to "EXIT" and press the TEST BUTTON to return to the Game Mode.

FIG. 8.2 TEST MENU

### 8-3 MEMORY TEST

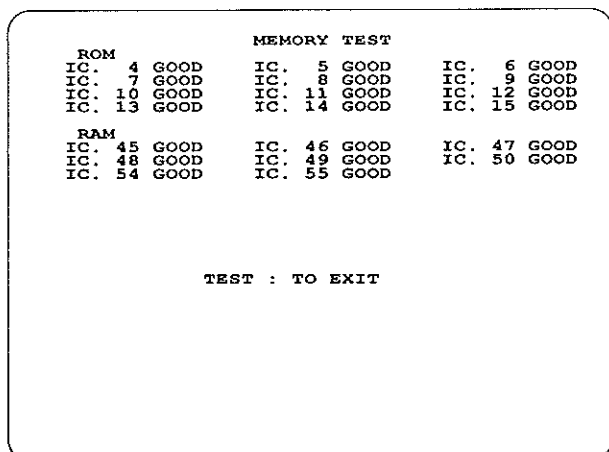

The MEMORY TEST mode is for checking the on-BD memory IC functioning. "GOOD" is displayed for normal ICs and "BAD" is displayed for abnormal ICs.

FIG. 8.3 MEMORY TEST

- When the test is completed, if the results are shown as above, it is satisfactory.
- It takes approximately 50 seconds to complete the test. If the period exceeds 50 seconds, this may have been caused by board malfunctioning.
- After finishing the test, pressing the TEST BUTTON allows the MENU mode to return on to the screen.

### 8-4 TGP TEST

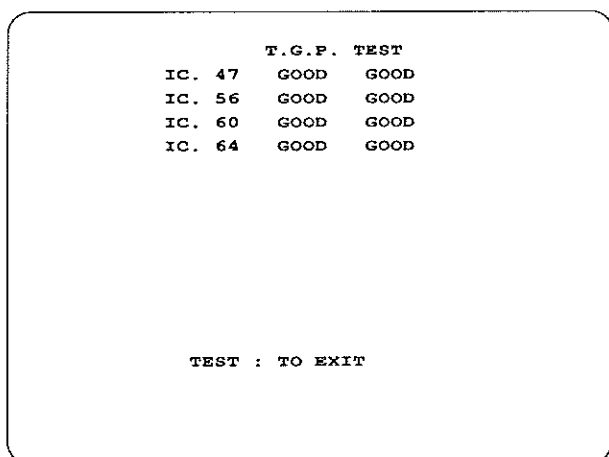

In this test, TGP (on-screen display related IC) is checked. As shown at the left, if "GOOD" is displayed for all, it is satisfactory. Press TEST BUTTON to return to the menu screen.

FIG. 8.4 TGP TEST

## 8-5 INPUT TEST

When INPUT TEST is selected, the Projector will show the following, allowing you to watch the status of each switch.  
On this screen, periodically check the status of each switch.

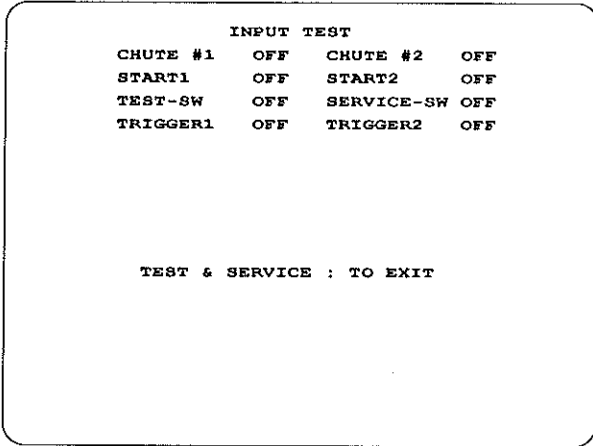

- By pressing each switch, if the display on the righthand side of the name of each switch changes to ON from OFF, the SW and the wiring connections are satisfactory.
- Open the COIN CHUTE DOOR and insert a coin from the COIN ENTRY to check the COIN CHUTE COIN SW.

In the INPUT test, pressing the TEST BUTTON and the SERVICE BUTTON simultaneously causes the menu to return to the screen.

FIG. 8.5 INPUT TEST

## 8-6 OUTPUT TEST

Choose OUTPUT TEST to cause the following upper screen to appear. In this test, periodically adjust the projector and check the status of each lamp.

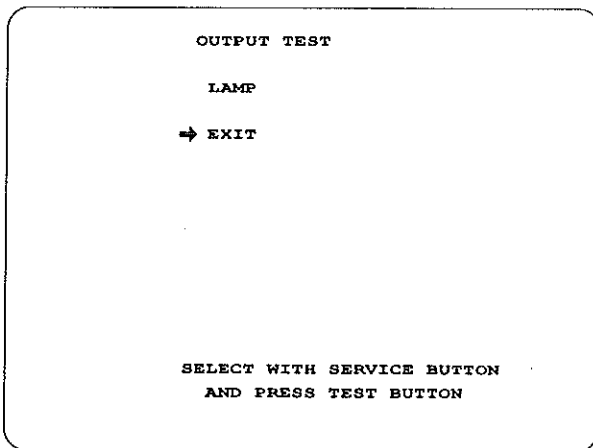

The FIG. at the left shows the menu mode of OUTPUT TEST. Press the SERVICE BUTTON to bring the arrow (→) to the desired test item. Periodically check the lamp status on this screen. Press the TEST BUTTON to cause the test mode screen below to appear. To return to the menu mode, bring the arrow to EXIT and press the TEST BUTTON.

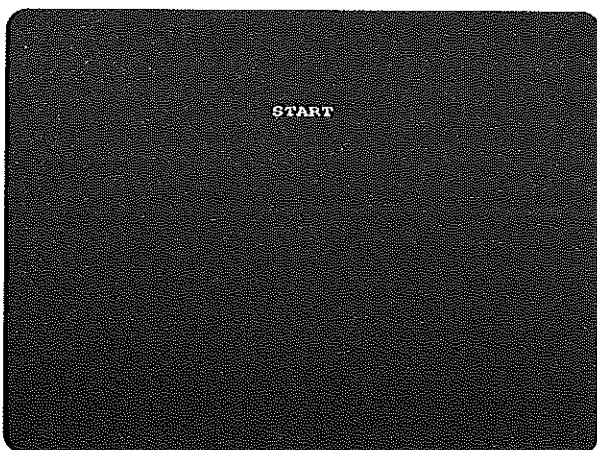

Choose LAMP to cause the screen shown at the left to appear, and both TEST BUTTONS to flash. Press the TEST BUTTON to have the above OUTPUT TEST menu return to the screen.

FIG. 8.6 OUTPUT TEST

## 8-7 SOUND TEST

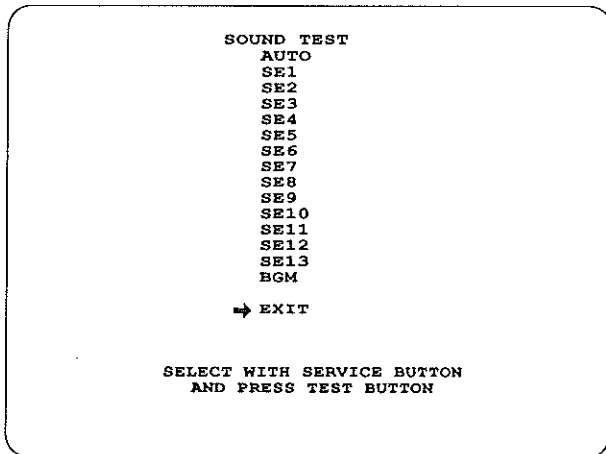

FIG. 8.7 SOUND TEST

- **AUTO:**  
 Auto play covering from SE1 to BGM. Bring the arrow to this item and press TEST BUTTON to cause SOUND TEST covering from SE1 to BGM to be automatically and repeatedly performed.

This enables sounds used in the game to be checked. Sound related memory and each speaker are checked. Press the SERVICE BUTTON to bring the arrow (→) to the desired sound item to be tested. Pressing the TEST BUTTON causes the desired sound test screen to appear.

Bring the arrow to EXIT and press the TEST BUTTON to return to the menu screen (FIG. 8.2).

In each sound test screen, pressing the SERVICE BUTTON to bring the arrow (→) to the desired sound item to be tested and pressing the TEST BUTTON causes the selected sound to be emitted.

- **SE\*:**  
 Sound effects during game.
- **BGM:**  
 Background music during game.

## 8-8 C.R.T. TEST

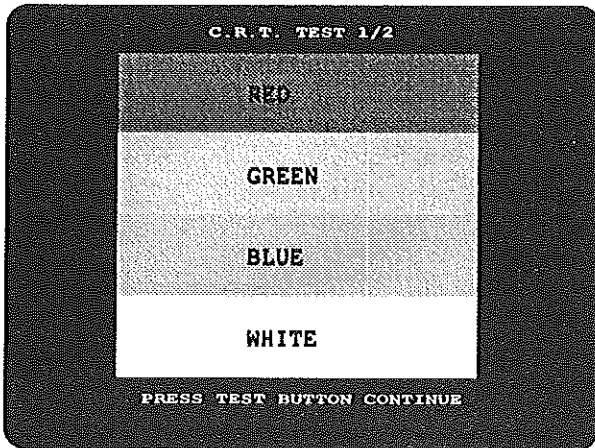

Select C. R. T. Test to cause the Projector to display the screen shown left, allowing Projector adjustment status to be checked.

Periodically check the Projector adjustment status on this screen.

The screen (1/2) enables color adjustment check to be performed. The color bar of each of the 4 colors, i. e., red, green, blue and white, is darkest at the extreme left and becomes brighter towards the extreme right.

Press the TEST BUTTON to shift to the next page (2/2).

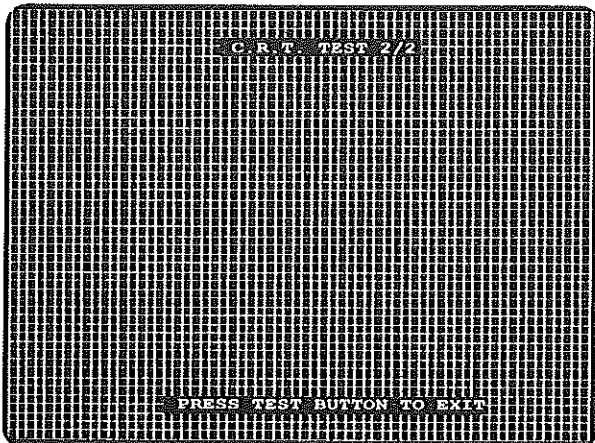

The screen (2/2) allows screen size and distortion to be tested.

Check if the Crosshatch Frame Line goes out of the screen and if the crosshatch lines are distorted.

Press the TEST BUTTON to return to the Menu mode. (FIG. 8.2)

FIG. 8.8 C.R.T. TEST

## 8-9 GAME ASSIGNMENTS

Selecting the GAME ASSIGNMENTS in the menu mode causes the present game setting to be displayed and also the game setting changes (game difficulty, etc.) can be made. Each item displays the following content.

### SETTING CHANGE PROCEDURE



IMPORTANT!

The setting can not be changed until "EXIT." When the setting is changed, be sure to "EXIT."

- ① Press the SERVICE BUTTON to move the arrow "→" to the desired item.
- ② Choose the desired setting change item by using the TEST BUTTON.
- ③ To return to the MENU mode, move the arrow to EXIT and press the TEST BUTTON.

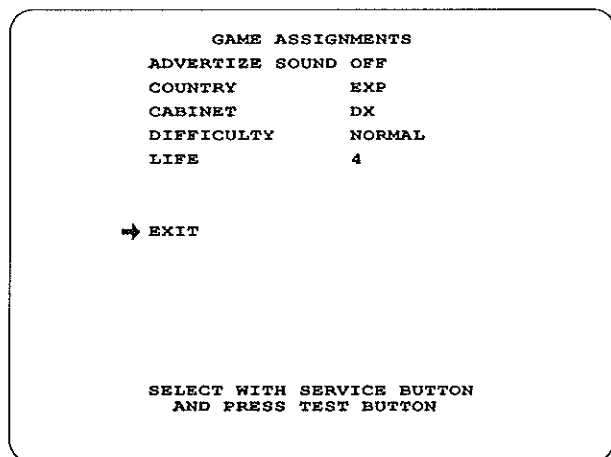

FIG. 8.9 GAME ASSIGNMENTS

- **ADVERTISE SOUND**  
Determines whether ADVERTISE SOUND is to be emitted or not by setting to ON when emitting it and to OFF when not emitting it.
- **COUNTRY**  
Message language (select USA for the U.S.A., and EXP for other countries)
- **CABINET**  
In this machine, the cabinet is set to "DX."
- **DIFFICULTY**  
The game difficulty levels can be set in 9 steps from EASIEST to HARDEST.
- **LIFE**  
This is the number of life points allotted at the time of starting game. Can be set from 1 to 9.

## 8-10 COIN ASSIGNMENTS

The "COIN ASSIGNMENTS" mode permits you to set the start number of credits, as well as the basic numbers of coins and credits. This mode expresses "how many coins correspond to how many credits."

### SETTING CHANGE PROCEDURE



IMPORTANT!

The setting can not be changed until "EXIT." When the setting is changed, be sure to "EXIT."

- ① Press the SERVICE BUTTON to move the arrow "→" to the desired item.
- ② Choose the desired setting change item by using the TEST BUTTON.
- ③ To return to the MENU mode, move the arrow to EXIT and press the TEST BUTTON.

COIN ASSIGNMENTS			
COIN CHUTE TYPE	COMMON		
CREDIT TO START	1	CREDIT (S)	
CREDIT TO CONTINUE	1	CREDIT (S)	
COIN/CREDIT SETTING #1			
CHUTE #1	1	COIN	1 CREDIT
CHUTE #2	1	COIN	1 CREDIT
MANUAL SETTING			
→ EXIT			
SELECT WITH SERVICE BUTTON AND PRESS TEST BUTTON			

- **COIN CHUTE TYPE**  
Sets the combination of the number of COIN CHUTES and the number of players as applicable. In the case that the COIN CHUTE is changed, be sure the setting is made in a manner meeting the replaced coin chute.

**INDIVIDUAL :**  
Each player uses a coin chute which accepts coins independently.

**COMMON :**  
Coins are accepted in common for both players.

FIG. 8. 10 COIN ASSIGNMENTS

- **CREDIT TO START**  
Number of credits required for starting game (1~5 credits are selected.)
- **CREDIT TO CONTINUE**  
Number of credits required for continuing game (1~5 credits are selected.)
- **COIN/CREDIT SETTING**  
Sets the CREDIT increase increment per coin insertion. There are 27 settings from #1 to #27, expressed in ○○ CREDIT as against ○○ COINS inserted. (TABLE 8. 2, 8.3) #27 refers to FREE PLAY.  
When the COIN CHUTE TYPE is set to INDIVIDUAL, there are some setting numbers not displayed as indicated in TABLE 8. 3.
- **MANUAL SETTING**  
This allows credit increase setting as against coin insertion to be further set in the manner finer than COIN/CREDIT SETTING (refer to Table 8. 4).

TABLE 8.2 COIN/CREDIT SETTING (COIN CHUTE COMMON TYPE)

SETTING	FUNCTIONING COIN CHUTE #1		FUNCTIONING COIN CHUTE #2	
SETTING #1	1 COIN	1 CREDIT	1 COIN	1 CREDIT
SETTING #2	1 COIN	2 CREDITS	1 COIN	1 CREDIT
SETTING #3	1 COIN	3 CREDITS	1 COIN	1 CREDIT
SETTING #4	1 COIN	4 CREDITS	1 COIN	1 CREDIT
SETTING #5	1 COIN	5 CREDITS	1 COIN	1 CREDIT
SETTING #6	1 COIN	2 CREDITS	1 COIN	2 CREDITS
SETTING #7	1 COIN	5 CREDITS	1 COIN	2 CREDITS
SETTING #8	1 COIN	3 CREDITS	1 COIN	3 CREDITS
SETTING #9	1 COIN	4 CREDITS	1 COIN	4 CREDITS
SETTING #10	1 COIN	5 CREDITS	1 COIN	5 CREDITS
SETTING #11	1 COIN	6 CREDITS	1 COIN	6 CREDITS
SETTING #12	2 COINS	1 CREDIT	2 COINS	1 CREDIT
SETTING #13	1 COIN	1 CREDIT	2 COINS	1 CREDIT
SETTING #14	1 COINS	2 CREDITS	2 COINS	1 CREDIT
SETTING #15	1 COIN	1 CREDIT	1 COIN	1 CREDIT
	2 COINS	3 CREDITS	2 COINS	3 CREDITS
SETTING #16	1 COIN	3 CREDITS	1 COIN	1 CREDIT
			2 COINS	3 CREDITS
SETTING #17	3 COINS	1 CREDIT	3 COINS	1 CREDIT
SETTING #18	4 COINS	1 CREDIT	4 COINS	1 CREDIT
SETTING #19	1 COIN	1 CREDIT	1 COIN	1 CREDIT
	2 COINS	2 CREDITS	2 COINS	2 CREDITS
	3 COINS	3 CREDITS	3 COINS	3 CREDITS
	4 COINS	5 CREDITS	4 COINS	5 CREDITS
SETTING #20	1 COIN	5 CREDITS	1 COIN	1 CREDIT
			2 COINS	2 CREDITS
			3 COINS	3 CREDITS
			4 COINS	5 CREDITS
SETTING #21	5 COINS	1 CREDIT	5 COINS	1 CREDIT
SETTING #22	1 COIN	2 CREDITS	3 COINS	1 CREDIT
			5 COINS	2 CREDITS
SETTING #23	2 COINS	1 CREDIT	2 COINS	1 CREDIT
	4 COINS	2 CREDITS	4 COINS	2 CREDITS
	5 COINS	3 CREDITS	5 COINS	3 CREDITS
SETTING #24	1 COIN	3 CREDITS	2 COINS	1 CREDIT
			4 COINS	2 CREDITS
			5 COINS	3 CREDITS
SETTING #25	1 COIN	1 CREDIT	1 COIN	1 CREDIT
	2 COINS	2 CREDITS	2 COINS	2 CREDITS
	3 COINS	3 CREDITS	3 COINS	3 CREDITS
	4 COINS	4 CREDITS	4 COINS	4 CREDITS
	5 COINS	6 CREDITS	5 COINS	6 CREDITS
SETTING #26	1 COIN	6 CREDITS	1 COIN	1 CREDIT
			2 COINS	2 CREDITS
			3 COINS	3 CREDITS
			4 COINS	4 CREDITS
			5 COINS	6 CREDITS
SETTING #27	FREE PLAY		FREE PLAY	



TABLE 8.3 COIN/CREDIT SETTING  
(COIN CHUTE INDIVIDUAL TYPE)

SETTING	FUNCTIONING OF EACH COIN CHUTE	
SETTING #1	1 COIN	1 CREDIT
SETTING #6	1 COIN	2 CREDITS
SETTING #8	1 COIN	3 CREDITS
SETTING #9	1 COIN	4 CREDITS
SETTING #10	1 COIN	5 CREDITS
SETTING #11	1 COIN	6 CREDITS
SETTING #12	2 COINS	1 CREDIT
SETTING #15	1 COIN	1 CREDIT
	2 COINS	3 CREDITS
SETTING #17	3 COINS	1 CREDIT
SETTING #18	4 COINS	1 CREDIT
SETTING #19	1 COIN	1 CREDIT
	2 COINS	2 CREDITS
	3 COINS	3 CREDITS
	4 COINS	5 CREDITS
SETTING #21	5 COINS	1 CREDIT
SETTING #22	3 COINS	1 CREDIT
	5 COINS	2 CREDITS
SETTING #23	2 COINS	1 CREDIT
	4 COINS	2 CREDITS
	5 COINS	3 CREDITS
SETTING #25	1 COIN	1 CREDIT
	2 COINS	2 CREDITS
	3 COINS	3 CREDITS
	4 COINS	4 CREDITS
	5 COINS	6 CREDITS
SETTING #27	FREE PLAY	

**MANUAL SETTING**

Selecting MANUAL SETTING in the Coin Assignment mode displays the following screen.

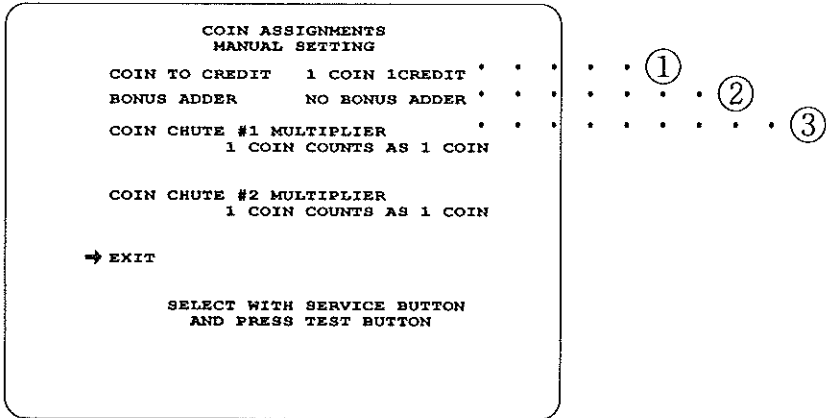

FIG. 8.10 b MANUAL SETTING

- ① Determines Coin /Credit setting.
- ② This sets how many coins should be inserted to obtain one Service Coin.
- ③ This sets how many tokens one coin represents.

Table 8.4 MANUAL SETTING

COIN TO CREDIT	1 COIN	1 CREDIT
	2 COINS	1 CREDIT
	3 COINS	1 CREDIT
	4 COINS	1 CREDIT
	5 COINS	1 CREDIT
	6 COINS	1 CREDIT
	7 COINS	1 CREDIT
	8 COINS	1 CREDIT
	9 COINS	1 CREDIT
BONUS ADDER	NO BONUS ADDER	
	2 COINS GIVE	1 EXTRA COIN
	3 COINS GIVE	1 EXTRA COIN
	4 COINS GIVE	1 EXTRA COIN
	5 COINS GIVE	1 EXTRA COIN
	6 COINS GIVE	1 EXTRA COIN
	7 COINS GIVE	1 EXTRA COIN
	8 COINS GIVE	1 EXTRA COIN
	9 COINS GIVE	1 EXTRA COIN
COIN CHUTE MULTIPLIER	1 COIN COUNTS AS	1 COIN
	1 COIN COUNTS AS	2 COINS
	1 COIN COUNTS AS	3 COINS
	1 COIN COUNTS AS	4 COINS
	1 COIN COUNTS AS	5 COINS
	1 COIN COUNTS AS	6 COINS
	1 COIN COUNTS AS	7 COINS
	1 COIN COUNTS AS	8 COINS
	1 COIN COUNTS AS	9 COINS

## 8-11 GUN SETTING

Selecting GUN SETTING causes the following screen shown at the top to appear. This allows the controller sighting to be adjusted. Periodically check the sighting adjustment status on this screen.

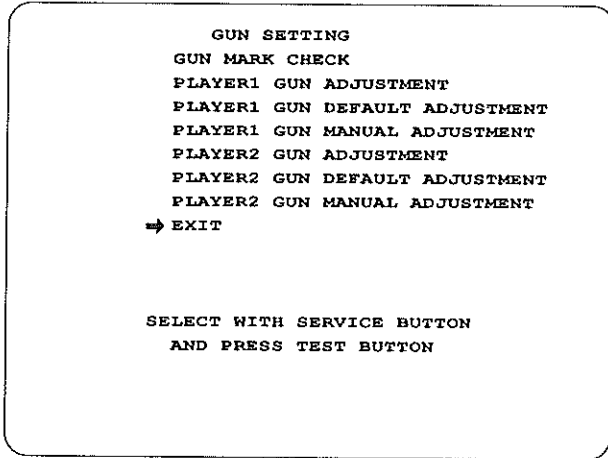

FIG. 8. 11 a SIGHTING ADJUSTMENT MENU

The screen shown at the left is the sighting adjustment menu mode. Press the SERVICE BUTTON to bring the (→) arrow to the desired adjustment item to select.

Press the TEST BUTTON to cause the following sighting check screen and sighting adjustment screen to appear. Each of 1P side and 2P side has 3 different kinds of adjustments to be made.

Adjustments for both 1P and 2P can not be made on the same screen.

To return to the menu, bring the arrow to EXIT and press the TEST BUTTON (FIG. 8.2).

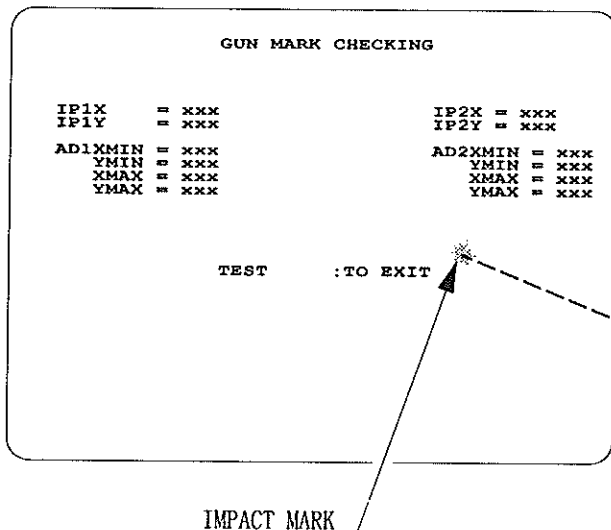

Selecting GUN MARK CHECK causes the screen at the left to appear. Point the controller at this screen to have an impact mark appear on the screen. The position of the mark shows the impact point shot by the controller. A blue impact mark applies to the 1P side and a red one to the 2P side. Perform sighting check on this screen.

Press the TEST BUTTON to return to the above sighting adjustment menu screen.

FIG. 8. 11 b SIGHTING CHECK

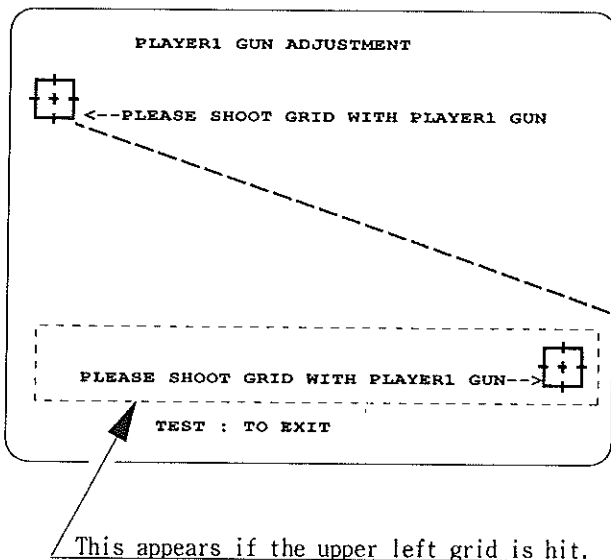

Selecting PLAYER 1 GUN ADJUSTMENT causes the screen shown at the left to be displayed.

1P side sighting adjustment can be made on this screen. If the TEST BUTTON is pressed, the sighting adjustment menu returns to the screen without performing anything.

Adjustment procedure: First shoot at the center of the grid (the square mark at the upper left portion of the screen). This causes another grid to appear at the lower right portion of the screen. Shoot at this grid also. (To be continued.)

FIG. 8. 11 c SIGHTING ADJUSTMENT

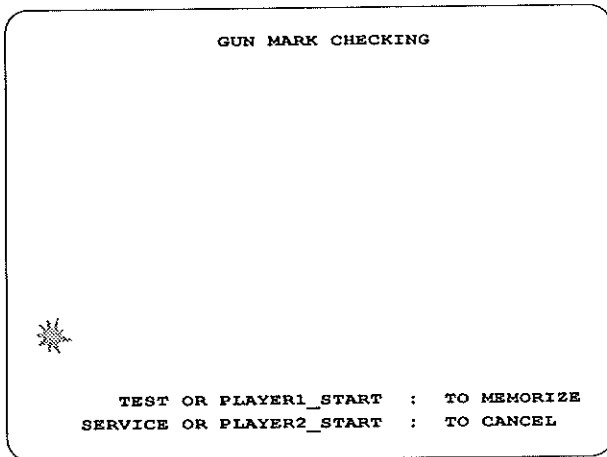

FIG. 8. 11 d SIGHTING ADJUSTMENT SELECTION

After shooting at the 2 grids, the screen shown at the left appears. In this screen, choose if the adjustment made is satisfactory or not. Pointing the controller at the screen causes the impact mark to be displayed. The mark shows the shot impact position.

If the adjustment is satisfactory, press the TEST BUTTON or 1P side start button. For readjustment, press the SERVICE BUTTON or 2P side start button.

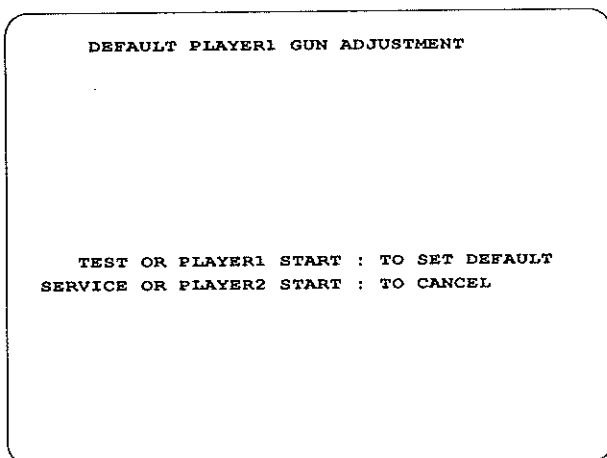

FIG. 8. 11 e SIGHTING ADJUSTMENT

Choosing PLAYER 1 GUN DEFAULT ADJUSTMENT causes the screen shown at the left to be displayed. The sighting is reset to the initial setting made at the time of shipment from the factory.

However, due to some changes in the unit's environment and cabinet after shipment, sighting may not be always accurate. To reset to the initial setting, press the TEST BUTTON or 1P side start button. To return to the sighting adjustment menu without doing anything, press the SERVICE BUTTON or 2P side start button.

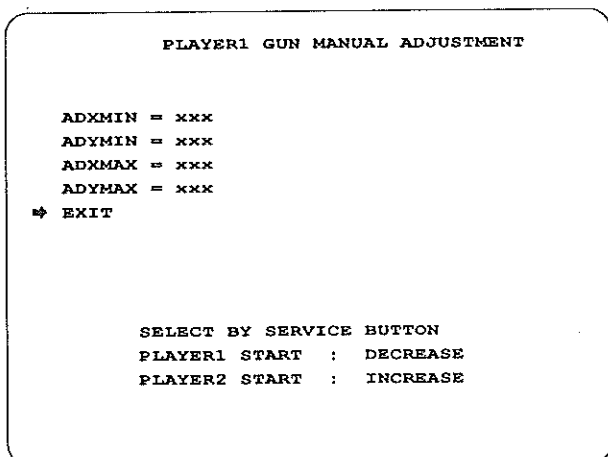

FIG. 8. 11 f SIGHTING ADJUSTMENT

Select PLAYER GUN MANUAL ADJUSTMENT to cause the screen shown at the left to be displayed. In this screen, the 4 adjustment values which determine sighting can directly be set. Use this adjustment mode only when accurate sighting can not be achieved in the above 2 screens. When setting each of the 4 adjustment values, follow the procedure below: Be sure to shoot at the screen's end portion in the designated direction and determine the adjustment value by paying attention to the impact mark movement.

### ADXMIN = xxx

Determines the adjustment value of the left-hand end in the horizontal direction. By pointing the controller at the screen's left-hand end, bring the impact mark to the left end of the screen. While pointing at the screen's left-hand end, pressing the left and right start buttons to change the adjustment value causes the impact mark to move left and right. Make adjustments in a manner so that the impact mark is at an appropriate position. At this time, disregard vertical directions.

### ADYMIN = xxx

Determines the adjustment value of the screen's upper end in the vertical direction. Point the controller at the screen's upper end to bring the impact mark to the screen's upper end. While pointing at the screen's upper end, changing the adjustment value by pressing the left and right start buttons causes the impact mark to move up and down. Make adjustments in a manner so that the impact mark is at an appropriate position. At this time, disregard horizontal directions.

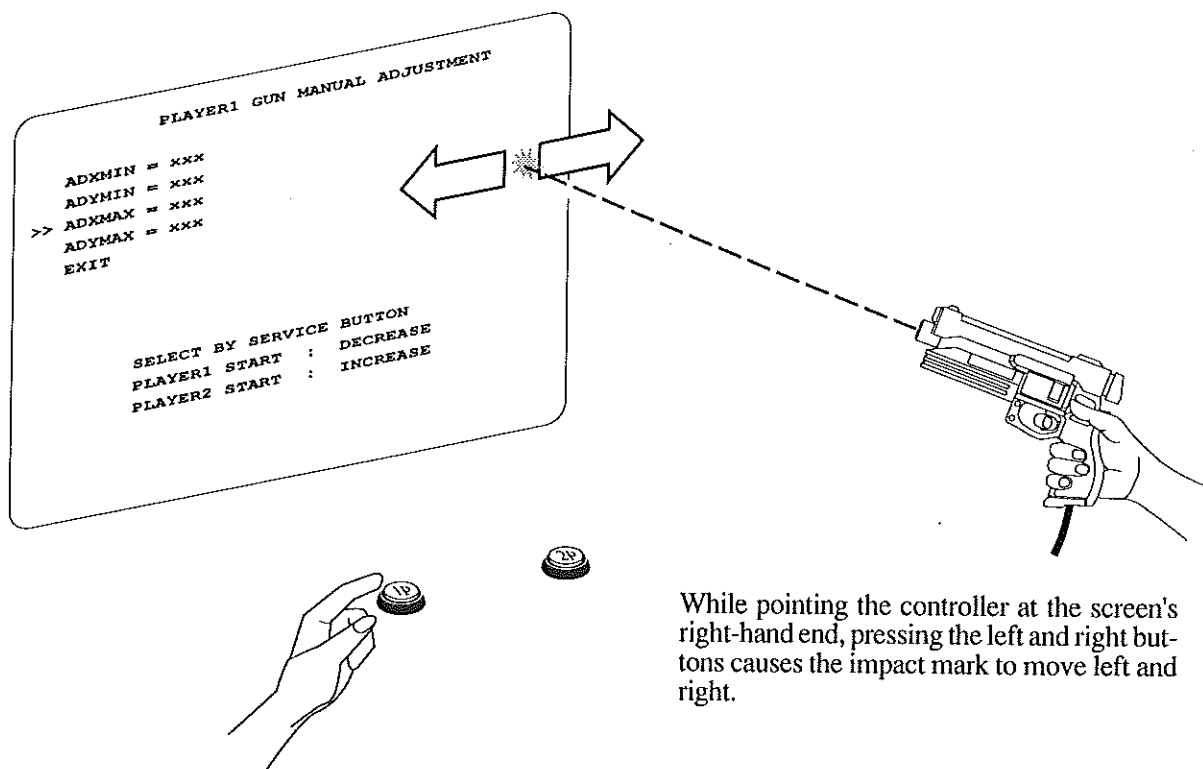

FIG. 8. 11 g SIGHTING ADJUSTMENT ( in the case of ADXMAX)

**ADXMAX = XXX**

Determines the adjustment value of the screen's right-hand end in the horizontal direction. Point the controller at the screen's right-hand end to bring the impact mark to the screen's right-hand end. While pointing at the screen's right-hand end, changing the adjustment value by pressing the left and right hand start buttons causes the impact mark to move left and right. Make adjustments in a manner so that the impact mark is at an appropriate position. At this time, disregard vertical directions.

**ADYMAX = XXX**

Determines the adjustment value of the screen's lower end in the vertical direction. Point the controller at the screen's lower end to bring the impact mark to the screen's lower end. While pointing at the lower end, changing the adjustment value by pressing the left and right start buttons causes the impact mark to move up and down. Make adjustments in a manner so that the impact mark is at an appropriate position. At this time, disregard horizontal directions.

Choosing PLAYER 2 GUN ADJUSTMENT causes 2P side sighting adjustment screen to be displayed. How to operate is the same as for 1P side.

Choosing PLAYER 2 GUN DEFAULT ADJUSTMENT causes 2P side sighting to be reset to the initial setting. How to operate is the same as for 1P side.

Choosing PLAYER 2 GUN MANUAL ADJUSTMENT causes the screen to adjust the 4 adjustment values for 2P side to appear. How to operate is the same as for 1P side.

## 8-12 BOOKKEEPING

Selecting the BOOKKEEPING in the menu mode causes the bookkeeping data up to the present to be displayed on 2 pages. To proceed to another screen, press the SERVICE BUTTON. Pressing the TEST BUTTON (on any screen page) causes the menu to return to the screen.

```

BOOKKEEPING 1/2

COIN CHUTE #1      xxxxxxxxxxxx
COIN CHUTE #2      xxxxxxxxxxxx
TOTAL COINS        xxxxxxxxxxxx

COIN CREDITS       xxxxxxxxxxxx
SERVICE CREDITS   xxxxxxxxxxxx
TOTAL CREDITS      xxxxxxxxxxxx

NUMBER OF GAMES    xxxxxxxxxxxx

TOTAL TIME         xDxxHxxMxxS
GAME PLAY TIME     xDxxHxxMxxS
AVERAGE GAME TIME xxMxxS
LONGEST GAME TIME  xxMxxS
SHORTEST GAME TIME xxMxxS

PRESS TEST BUTTON TO CONTINUE
    
```

FIG. 8.12 a BOOKKEEPING(1/2)

- COIN CHUTE#\* :  
Number of coins put in
- TOTAL COINS:  
Total number of activations of coin chutes
- COIN CREDITS:  
Number of credits registered by inserting coins
- SERVICE CREDITS:  
Credits registered by the SERVICE BUTTON
- TOTAL CREDITS:  
Total number of credits (COIN CREDITS + SERVICE CREDITS)
- TOTAL TIME:  
The total energized time

```

BOOKKEEPING 2/2

TOTAL PLAY GAMES  xxxxxxxxGAMES
CONTINUE GAMES   xxxxxxxxGAMES
P1 GAMES          xxxxxxxxGAMES
P2 GAMES          xxxxxxxxGAMES

TIME HISTOGRAM

0M00S~ 0M29S    xxxxxxxx
0M30S~ 0M59S    xxxxxxxx
1M00S~ 1M29S    xxxxxxxx
1M30S~ 1M59S    xxxxxxxx
2M00S~ 2M29S    xxxxxxxx
2M30S~ 2M59S    xxxxxxxx
3M00S~ 3M29S    xxxxxxxx
3M30S~ 3M59S    xxxxxxxx
4M00S~ 4M29S    xxxxxxxx
4M30S~ 4M59S    xxxxxxxx
OVER 5M00S      xxxxxxxx

PRESS TEST BUTTON TO EXIT
    
```

FIG. 8.12 b BOOKKEEPING(2/2)

On page (2/2), each play frequency is displayed. When setting difficulty levels, the frequency can be referred to as a standard.

- P1 GAMES:  
Games played on 1P side.
- P2 GAMES:  
Games played on 2P side.
- TIME HISTOGRAM  
By-playtime play frequency.

## 8-13 BACKUP RAM CLEAR

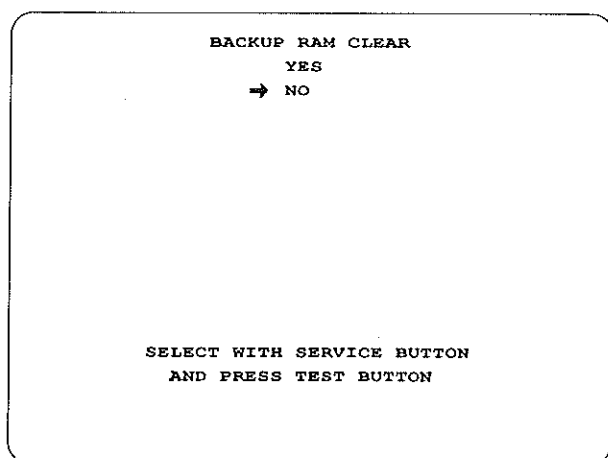

Clears the contents of BOOKKEEPING and high score player ranking entry. When clearing, bring "→" to "YES" and when not clearing, to "NO", by using the SERVICE BUTTON, and then push the TEST BUTTON. When the data has been cleared, "COMPLETED" will be displayed. Bring "→" to "NO" and press the TEST BUTTON to cause the Menu mode to return on to the screen. Note that the contents of game setting and sighting adjustment are not affected by BACKUP RAM CLEAR operation.

FIG. 8. 13 BACKUP RAM CLEAR

## 9. CONTROLLER (GUN)

In the cases where the controller's operation is not satisfactory or the controller sight deviates from the direction in which the controller is pointed, it is possible that some maintenance may be required (the controller's interior parts may have been damaged). Replace the parts by disassembling the controller in the following procedure: Also, be sure to perform sighting check in the test mode when the controller parts are replaced.

### 9-1 REPLACING THE MICROSWITCH

- ① Disassemble the controller.
- ② Pull out the microswitch from COVER RIGHT.
- ③ Take out the microswitch by removing the soldering from it.
- ④ Solder the new microswitch and assemble the controller.

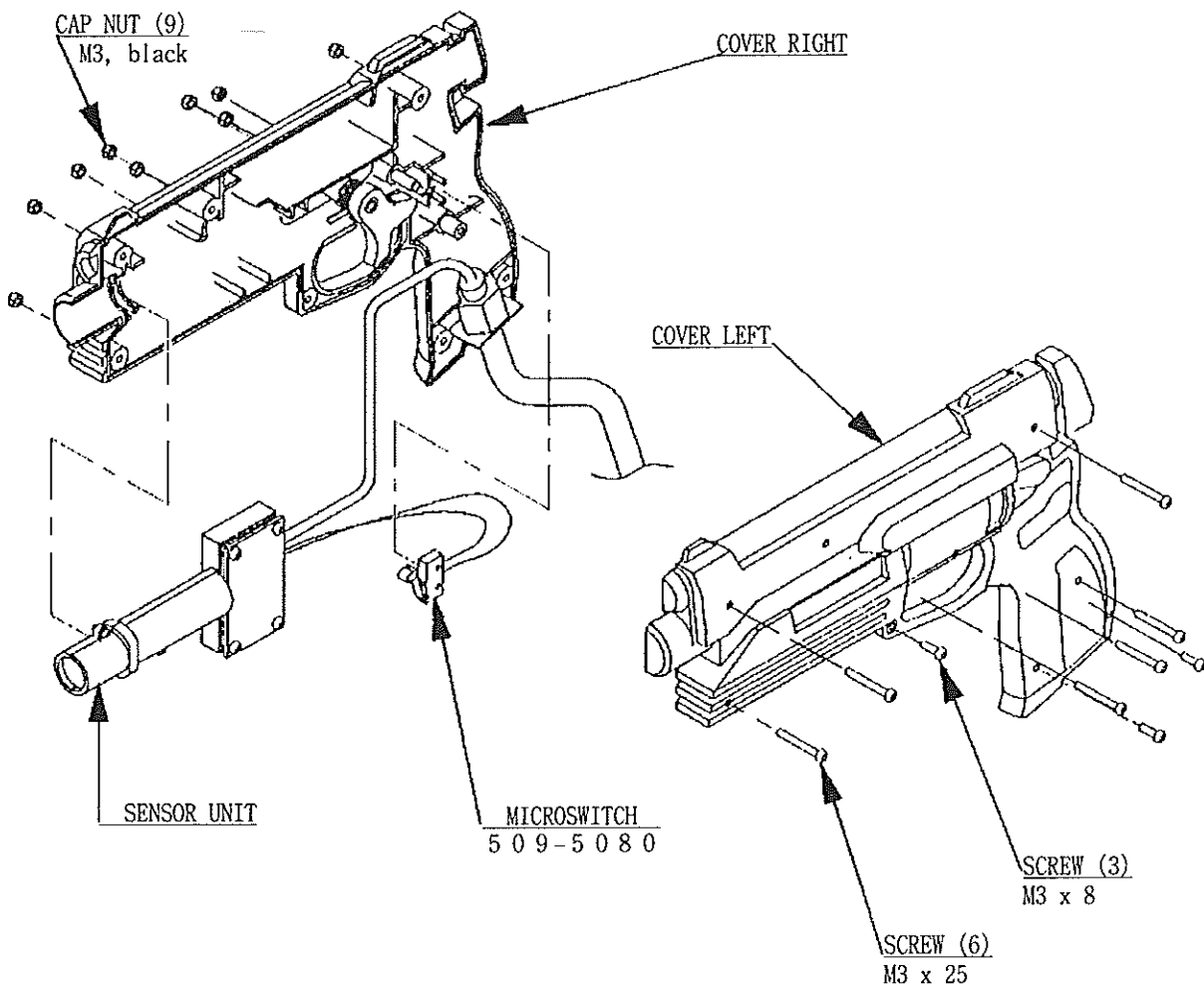

FIG. 9.1



## 9-2 REPLACING THE SENSOR BOARD

The sensor board fits in between LENS HOLDER L and LENS HOLDER R. Replace the sensor board by disassembling sensor unit in the following procedure:

- ① Disassemble the controller.
- ② Remove the sensor unit from COVER R.
- ③ Take off the 2 tapping screws to remove LENS HOLDER L.
- ④ Take off the 4 tapping screws and remove the sensor board from LENS HOLDER R.

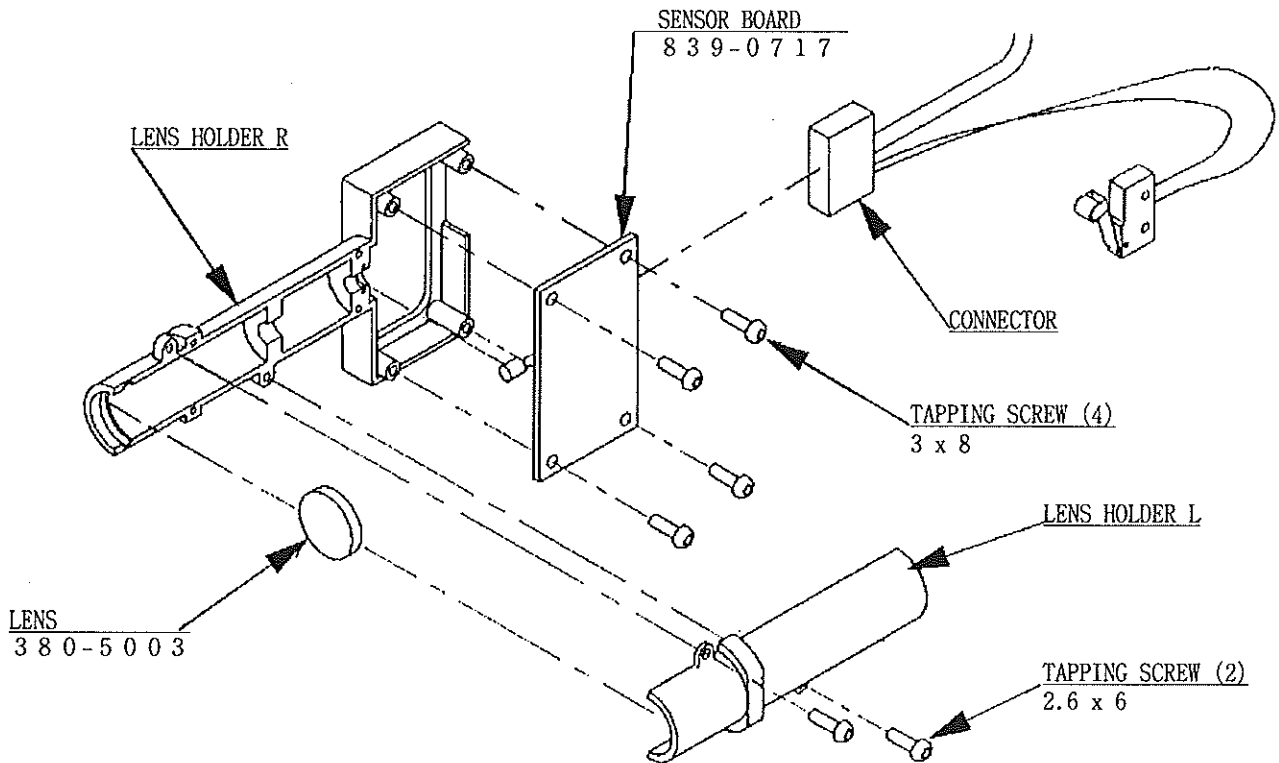

FIG. 9.2

# 10. COIN SELECTOR

## HANDLING THE COIN JAM

If the coin is not rejected even when the REJECT button is pressed, open the coin chute door and open the selector gate. After removing the jammed coin, put a normal coin in and check to see that the selector correctly functions.

## CLEANING THE COIN SELECTOR

The coin selector should be cleaned once every 3 months. When cleaning, follow the procedure below:

- ① Turn the power for the machine OFF. Open the coin chute door.
- ② Open the gate and dust off by using a soft brush (made of wool, etc.).
- ③ Remove stain by wiping with a soft cloth which contains water or chemical detergent.
- ④ Remove the CRADLE.  
When removing the retaining ring (E ring), be very careful so as not to bend the shaft.
- ⑤ Remove stain from the shaft and pillow portions by wiping off with a soft cloth, etc.
- ⑥ After wiping off as per 5 above, further apply a dry cloth, etc. to cause the coin selector to dry completely.



- Never apply machine oil, etc. to the Coin Selector.
- After cleaning the Coin Selector, insert a regular coin in the normal working status and ensure that the Selector correctly functions.

### COIN INSERTION TEST

Once every month, when performing the Coin SW Test, simultaneously check the following:

- Does the Coin Meter count satisfactorily?
- Does the coin drop into the Cashbox correctly?
- Is the coin rejected when inserted while keeping the Reject Button pressed down?

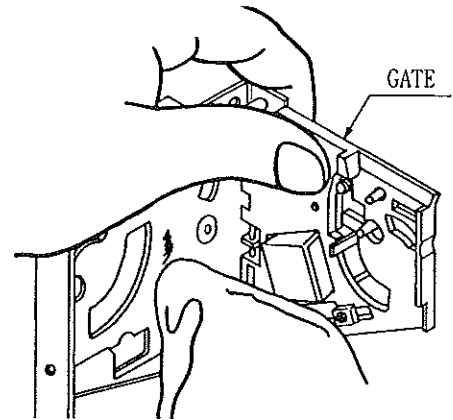

FIG. 10 a

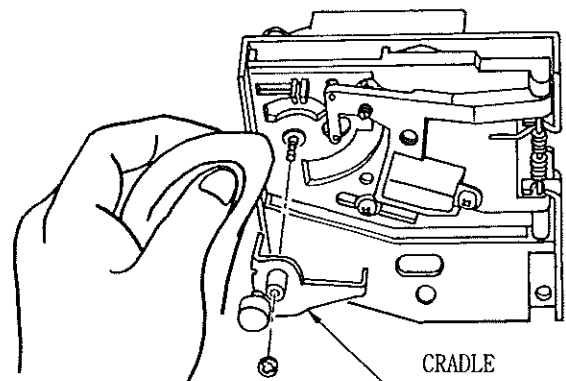
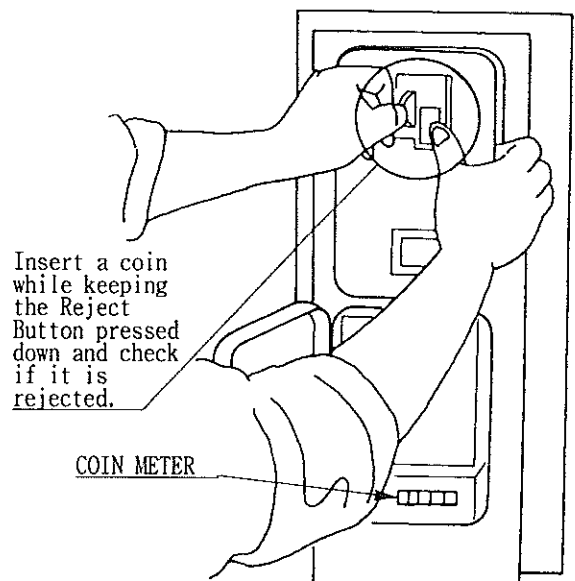

FIG. 10 b



Insert a coin while keeping the Reject Button pressed down and check if it is rejected.

FIG. 10 c

# 11. PROJECTOR



- Since the Projector screen is susceptible to damage, pay careful attention to its handling. When cleaning, refrain from using water or volatile chemicals.
- Since the Projector has been adjusted at the time of shipment, avoid making further adjustments without good reason.

Fine adjustments are stored in the Projector. Pressing the Fine Adjustment SW (Convergence Adjustment) results in entering the Fine Adjustment mode, and this may cause the stored fine adjustment to be changed. During work other than for adjustment, should you touch the Fine Adjustment SW by mistake, immediately turn the power off by using the main SW and then turn it back on again. If any distortion or color deviation is found in the test mode and adjustments are needed, use the specified Adjustment knob, or perform the adjustment by remote control. Note that there are two PROJECTOR makes (HITACHI & MITSUBISHI) and the adjustment method is different between the two. When checking the Adjustment Control knob, remove the PTV's Service Door. For the HITACHI Projector, open the cover in front of the control panel. For the MITSUBISHI Projector, remove the cover.



IMPORTANT!

The Projector is subject to color deviation due to Convergence deviation caused by the geomagnetism at the installation location and peripheral magnetic field. After the installation of machine, and before commencing operation, check for Convergence deviation and if deviated, make adjustments.

## 11-1 CLEANING THE SCREEN

When the screen surface becomes dirty with dust, etc., clean it by using a soft cloth such as gauze. When water, and volatile chemicals such as benzine, thinner, etc., spill on the screen surface, it may be subject to damage, therefore, do not use them. Also, since the surfaces are susceptible to damage, refrain from rubbing them with a hard material or using a duster.

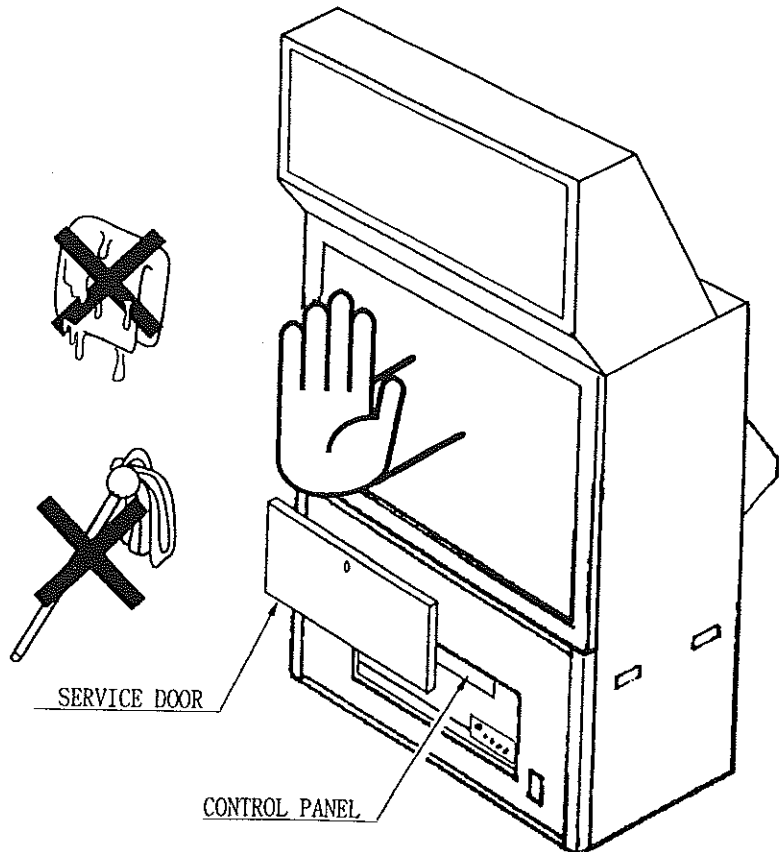

11-2 ADJUSTING HITACHI PROJECTORS



Never touch places other than those specified. Otherwise, hazardous electric shock or short-circuit can be caused.

There are 2 types of HITACHI PROJECTORS. As shown below, the Control Panel's layout differs from each other. The lower layout allows Static Convergence to be adjusted merely by operating the Remote Control.

□ HITACHI PROJECTOR CONTROL PANEL

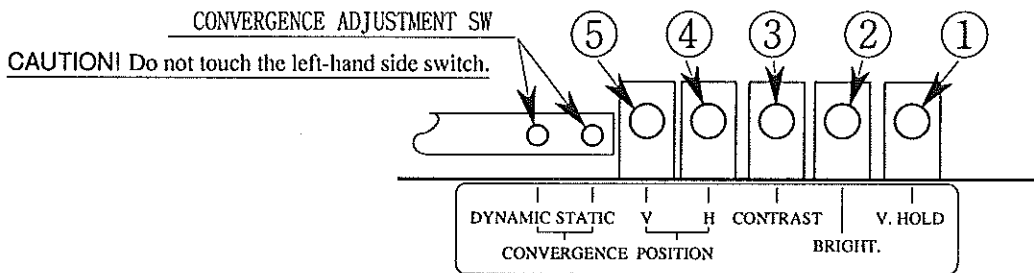
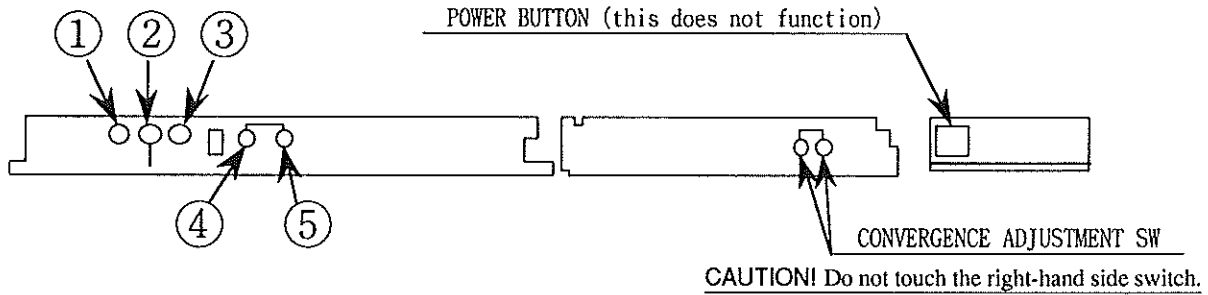

- ① V.HOLD
- ② BRIGHT
- ③ CONTRAST
- ④ H. POSITION
- ⑤ V. POSITION

STATIC CONVERGENCE ADJUSTMENT



Do not touch the Dynamic Convergence Adjustment SW. Dynamic Convergence adjustment work is quite troublesome and the visual effect is expected to be negligible. As such, no explanation is given in this manual. Should the SW be pressed by mistake or otherwise, turn the power off and turn it back on again.

CROSS PATTERN

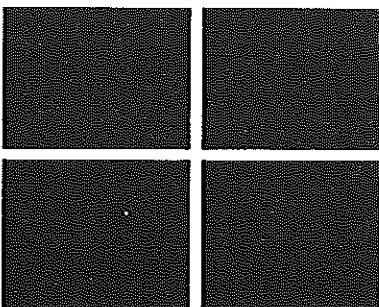

- ① Press the Static Convergence Adjustment SW which is on the Control Panel to cause the cross pattern to appear.
- ② Use the remote control to make static adjustment. For the operation of the Remote Controller, refer to the following pages.
- ③ Press the Static Convergence SW. At this time, static adjustment results are written and the PTV screen will return to the original screen mode.

The Remote Controller has 2 different types. Depending on the specific type, the adjustment procedure varies.

In the case of Remote Controller (Part No. 200-5297):

REMOTE CONTROL

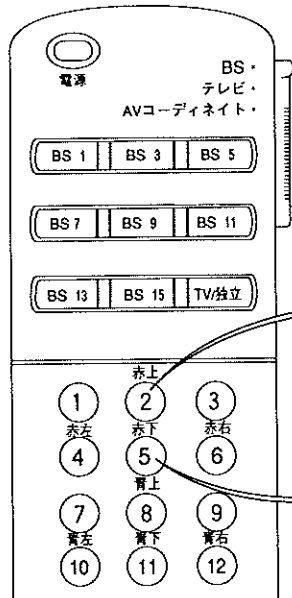

Entering Projector's Convergence Adjustment Mode allows the Crosshatch to be displayed on the screen. At this time, if the horizontal and vertical lines (of the cross) are not blurred and displayed in white, the convergence status is correct. If red or blue color is blurred from the line, the convergence is incorrect. In this case, make adjustment in the following Adjustment Procedure to return to the correct convergence status.

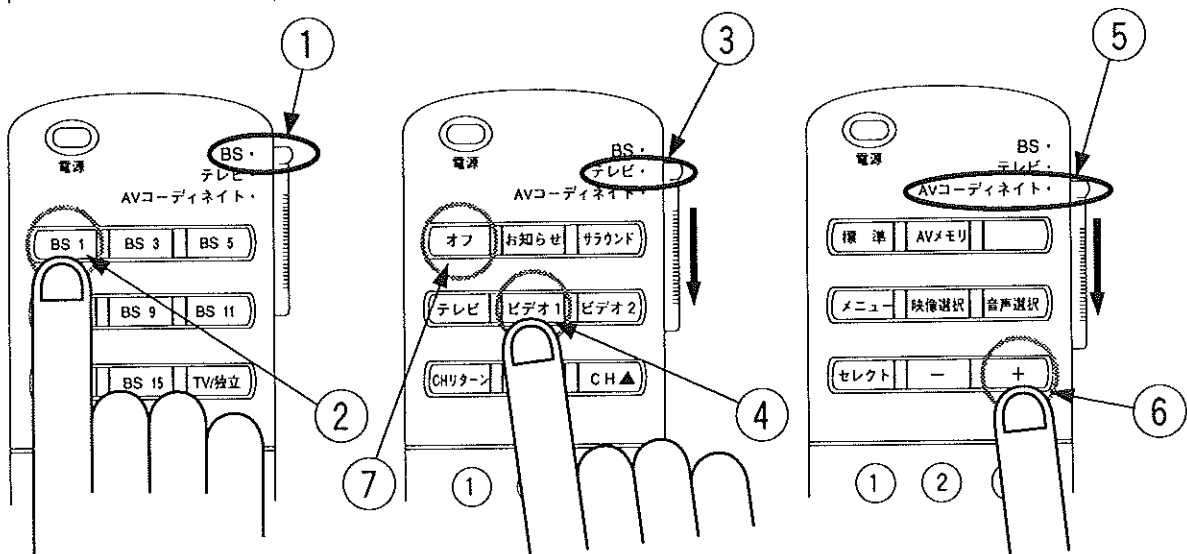
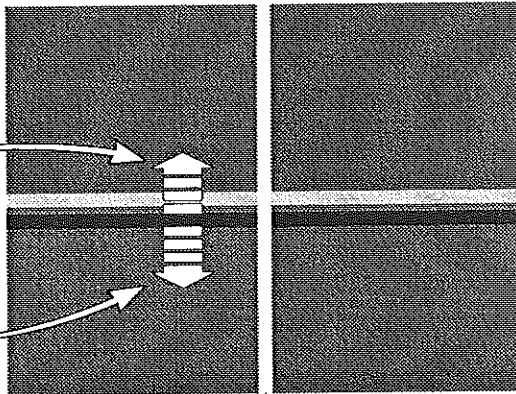

- ① Make sure that the slide portion of the Remote Control is positioned as per ① above.
- ② Press BS1.
- ③ Position the slide portion of the Remote Control to ③ in the above Figure.
- ④ Press VIDEO 1.
- ⑤ Position the Remote Control's slide portion to the above ⑤.
- ⑥ Press "+" to have the cross pattern appear.
- ⑦ Use the remote cotroller to make static adjustment.

Remote control [ 2 ], [ 5 ] ..... Causes the red horizontal line to match with the green horizontal line.

Remote control [ 4 ], [ 6 ] ..... Causes the red vertical line to match with the green vertical line.

Remote control [ 8 ], [ 11 ] ..... Causes the blue horizontal line to match with the green horizontal line.

Remote control [ 10 ], [ 12 ] ..... Causes the blue vertical line to match with the green vertical line.

- ⑧ Position the Remote Control's slide portion to ③ in the above Figure and push "OFF" 5 times to return to the normal mode.

In the case of Remote Controller (Part No. 200-5410):

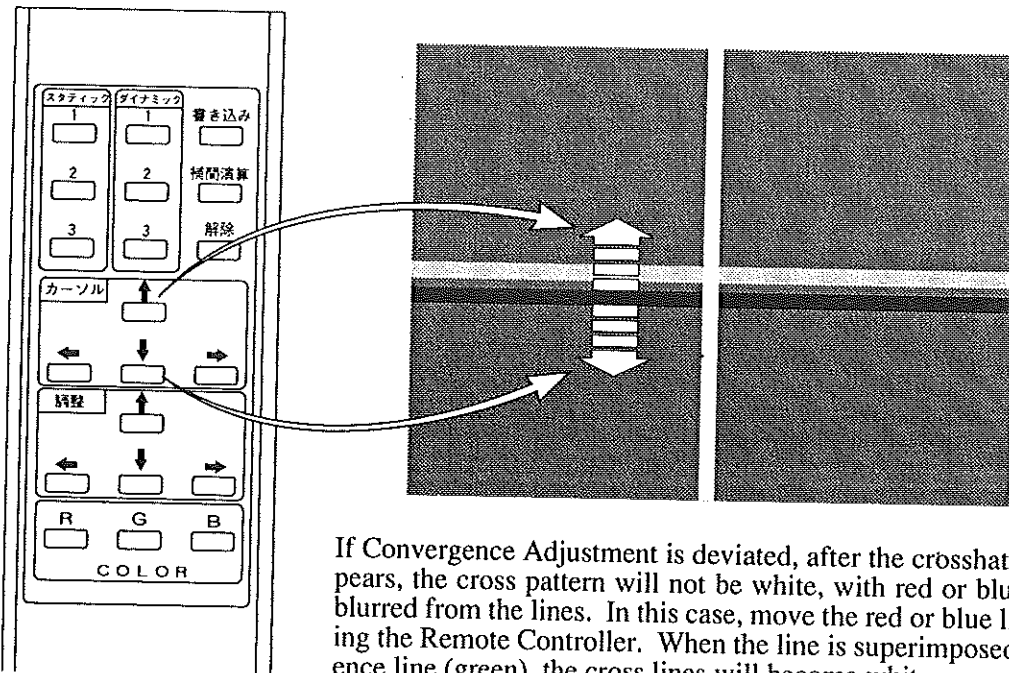

If Convergence Adjustment is deviated, after the crosshatch pattern appears, the cross pattern will not be white, with red or blue color being blurred from the lines. In this case, move the red or blue line by operating the Remote Controller. When the line is superimposed on the reference line (green), the cross lines will become white.

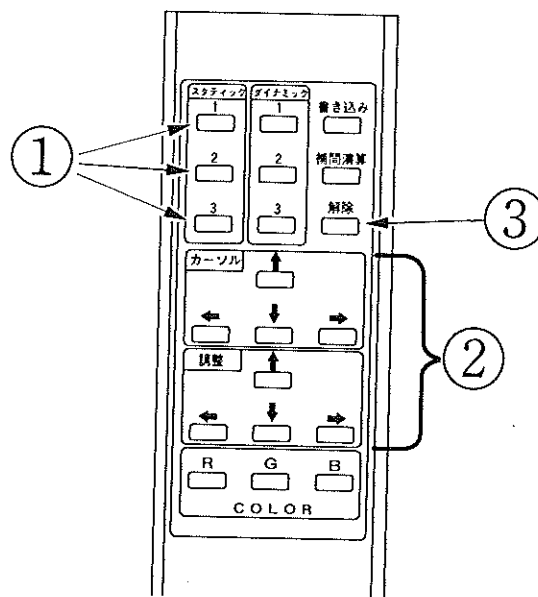

- ① Have the Remote Controller face the Projector screen and press Key 1, 2, and 3 (Portion ① shown) for Static Convergence Adjustment sequentially in order, causing the cross pattern to be displayed.
- ② Press the following arrow keys (Portion ② shown) to make adjustments.
  - Cursor    ↑↓ ..... Causes the red horizontal line to match with the green horizontal line.
  - Cursor    →← ..... Causes the red vertical line to match with the green vertical line.
  - Adjustment ↑↓ ..... Causes the Blue horizontal line to match with the green horizontal line.
  - Adjustment →← ..... Causes the Blue vertical line to match with the green vertical line.
- ③ Press the CANCEL Key (Portion ③ shown) 5 times. This operation allows for returning to the original screen and at the same time storing the adjustment data.

13-3 MITSUBISHI PROJECTOR

□ MITSUBISHI PROJECTOR CONTROL PANEL

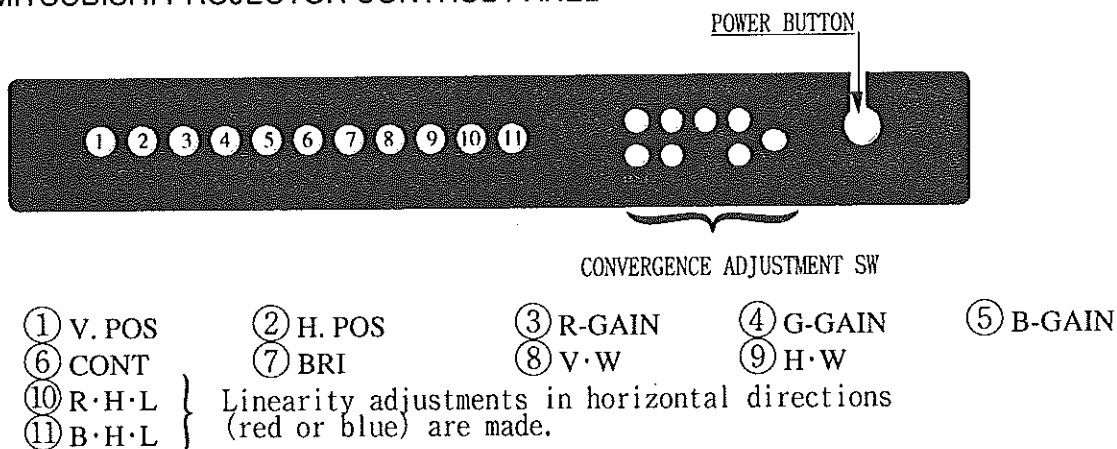

STATIC CONVERGENCE ADJUSTMENT

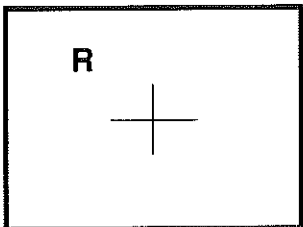
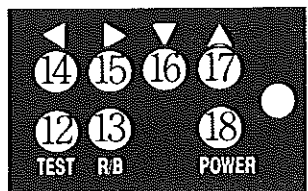

- |         |                      |
|---------|----------------------|
| ⑫ TEST  | Test mode on/off key |
| ⑬ R/B   | R/B shift key        |
| ⑭ ◀     | Left shift key       |
| ⑮ ▶     | Right shift key      |
| ⑯ ▽     | Lower shift key      |
| ⑰ ▲     | Upper shift key      |
| ⑱ POWER | Power button         |

- ① For the Convergence adjustment mode, press the test mode on/off key ⑫.
- ② Ensure that "R" is displayed on the screen.
- ③ Make adjustment so as to cause the red cross pattern to match with the green cross pattern by using Left Shift key ⑭, Right shift key ⑮, Lower shift key ⑯ and Upper shift key ⑰.
- ④ By using R/B shift key ⑬, cause the red adjustment "R" to shift to blue adjustment "B" and make sure that "B" is displayed on the screen.
- ⑤ In the same manner as in ③ above, cause the blue cross pattern to match with the green cross pattern.
- ⑥ After making adjustment, press the test mode on/off key ⑫ to cancel the Convergence adjustment mode.

## STATIC CONVERGENCE ADJUSTMENT WITH REMOTE CONTROL



- Although the remote control buttons other than the following do not function during convergence adjustment even if they are pressed, do not press them during the adjustment work.
- When operating the remote control, direct it on to the PTV screen.

### BEFORE USING THE REMOTE CONTROL:

First make sure that the main SW on the Projector's control panel is ON (the LED adjacent to the main SW is lit).

- ① For the Convergence Adjustment mode, press the test button (Figures 1·5 below). Ensure that "R" is displayed on the screen.
- ② Make adjustment so as to cause the red cross pattern to match with the green cross pattern. When the red cross matches the green cross, the green cross turns yellow or white (Figures 2·3·4 below).

Use remote control buttons shown below to move the red cross as follows:

- Button ⑤ ..... to the left.  
 ⑦ ..... to the right.  
 ② ..... Upward.  
 ⑩ ..... Downward.

- ③ Use Remote Control button ⑥ to shift "R" to "B." Make sure that "B" is displayed on the screen. Each time Button ⑥ is pressed, red and blue adjustments are shifted.
  - ④ In the same manner as in ② above, cause the blue cross to match with the green cross. When the blue cross matches with the green cross, the green cross turns white.
  - ⑤ After adjustment is made, press the test button (Figures 1·5 below) to cancel the Convergence Adjustment mode.
- ※ When 2 minutes or more elapses in the Convergence mode screen without taking any action, the on-screen adjustment mode will disappear.

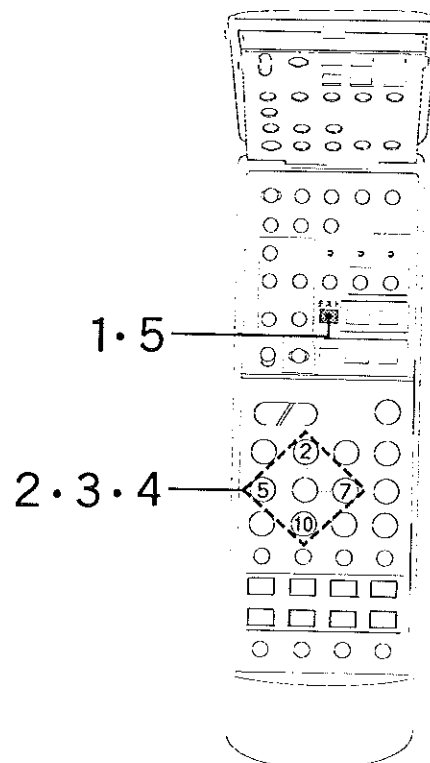
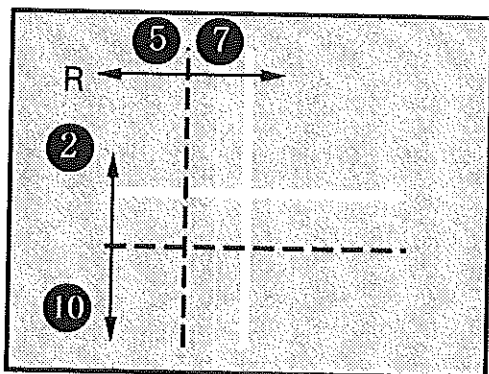



## 12. REPLACEMENT OF FLUORESCENT LAMP

### 12-1 FLUORESCENT LAMP REPLACEMENT

Remove the Billboard Holder and pull out the Billboard upward to replace the Fluorescent Lamp.

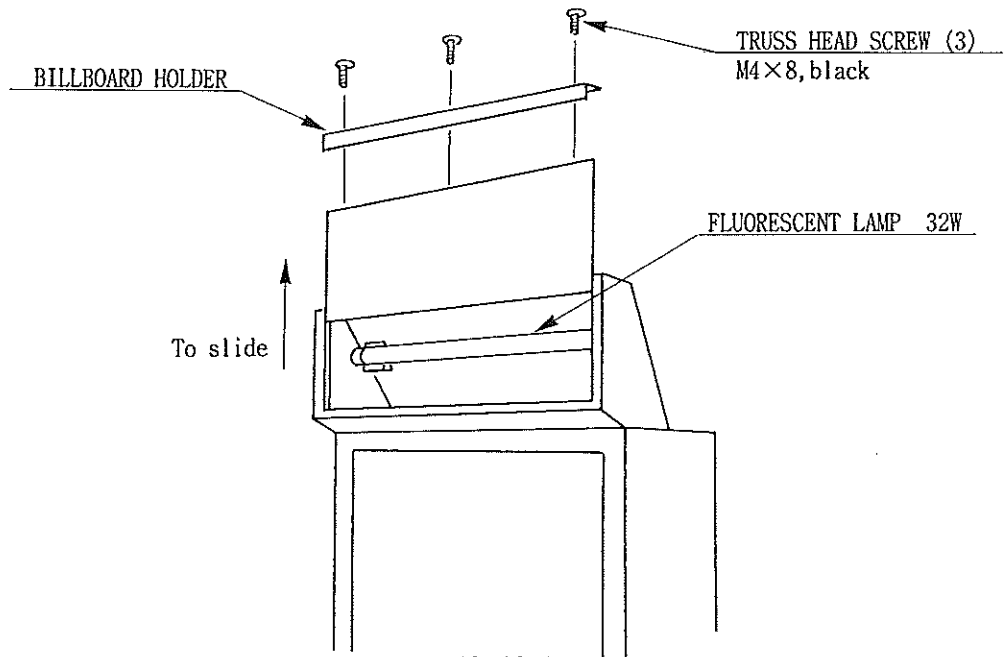
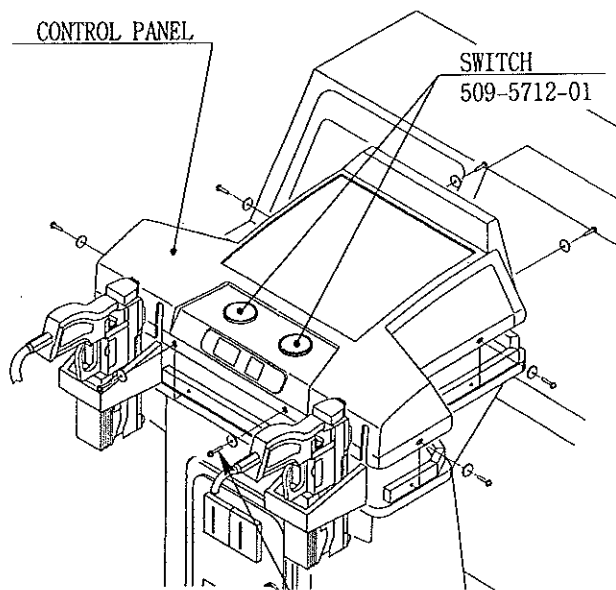

FIG. 12. 1

### 12-2 LAMP REPLACEMENT

- ① Take off the 8 Tamperproof Screws to remove the Control Panel upward. (FIG. 12. 2 a)
- ② Disconnect the Connector which comes from the Switch.
- ③ Pull the lower part of the Switch and remove the lamp portion to replace it. (FIG. 2. 2 b)



TAMPERPROOF SCREWS (8)  
M4 x 16, chromium plated,  
using flat washer

FIG. 12. 2 a

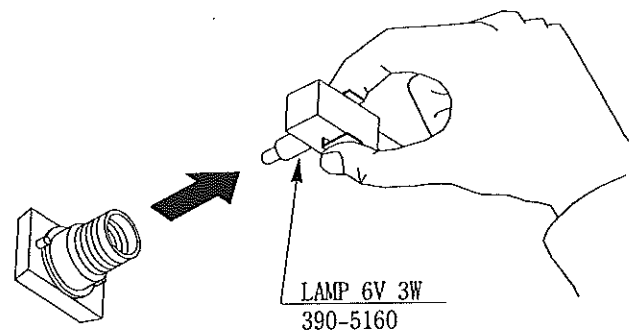

FIG. 12. 2 b

## 13. PERIODIC INSPECTION TABLE

The items listed below require periodic check and maintenance to retain the performance of this machine and ensure safe operation.

When handling the controller, the player will be in direct contact with it. In order to always allow the player to enjoy the game, be sure to clean it regularly. Also, it is advisable to provide wet tissue, etc. available for player use.



Be sure to clean the interior of the Cabinet and inspect & clean the Power Supply plug once a year. Using the Cabinet with dust as is accumulated can cause a fire and malfunctioning. Note that careless cleaning work can cause an accident and therefore, contact the place of contact herein stated or the distributor, etc. where the unit was purchased from. The interior cleaning service is available on a pay basis.

ITEMS	DESCRIPTION	PERIOD	REFERENCE
CONTROLLER	Cleaning	As required	
	Sight check	Weekly	8
	Check SWes.	Monthly	8
COIN SELECTOR	Check COIN SWes.	Monthly	8
	COIN SELECTOR cleaning.	Trimonthly	1 0
PROJECTOR	SCREEN cleaning.	Weekly	1 1
	Check adjustments.	Monthly	6、8、1 1
GAME BD	Setting check	Monthly	8
INTERIOR	Cleaning	Annually	See above.
POWER PLUG	Inspection and cleaning		

## 14. TROUBLESHOOTING

For troubleshooting, first check the connection of wiring connectors.

PROBLEMS	CAUSE	COUNTERMEASURES
With Main SW ON, no activation	Power is not supplied. Power supply/voltage is not correct. AC unit circuit protector causes the power to be off due to momentary overload.	Plug in correctly. Make sure that power supply/voltage is correct. Check circuit protector. Remove the cause of overload to reinstate the circuit protector (see Section 6).
PTV screen is blackened and no sound is emitted.	POWER SW is OFF. Connections within the base are defective. The CIRCUIT PROTECTOR functioned due to momentary overcurrent.	① Check to see if the power switch is ON. ② Check the BNC connector connections of the PTV TERMINAL BD and VPM BUFFER BD in CONTROL CABI. ③ Check the CIRCUIT PROTECTOR beside the POWER SUPPLY SW. If it functioned, restore it.

PROBLEMS	CAUSE	COUNTERMEASURES
PTV screen is all blue.	Irregular communications between each board.	① Check the communication cable connection between the Game BD and I/O BD.  ② Turn the Power SW back on again.
The color of the image on PTV screen is incorrect.	Connector connections are defective.	Check the connection for the RGB and SYNC Connectors of the PTV TERMINAL BD and VPM BUFFER BD.
The image on PTV screen has color deviation.	Affected by the magnetic field of installation location.	Make CONVERGENCE adjustment. (Refer to Section 11.)
No sound is emitted.	Sound volume adjustment is not appropriate.  Sound BD and speaker are malfunctioning.	Adjust sound volume (see Section 8).  Perform sound test to find and replace defective parts (See Section 8).
Controller operation is not satisfactory.	Due to environmental changes, etc., sighting became inappropriate.  Microswitch malfunctioning.  Sensor BD malfunctioning.	Perform sighting adjustment in the test mode (see Section 8).  Replace the microswitch (see Section 9).  Replace the sensor BD. (see Section 9).
The Fluorescent lamp does not light up.	The Fluorescent tube is burnt out.	Replace the Fluorescent tube with an FL 20W tube (refer to Section 12).



Functions due to the activation of bimetal .  
To restore the function, wait for approximately one minute or longer until the bimetal cools off.

# 15. GAME BOARD

## 15-1 REMOVING THE BOARD

Remove the Back Lid from Front Cabinet DX, disconnect the Connector which is connected to the Shield Case, and take out the Shield Case together with the Shield Case Base. Then, remove the Shield Case Lid to take out the Game BD. When taking out the Game BD from the Shield Case, ensure that the Shield Case is kept in a level status.

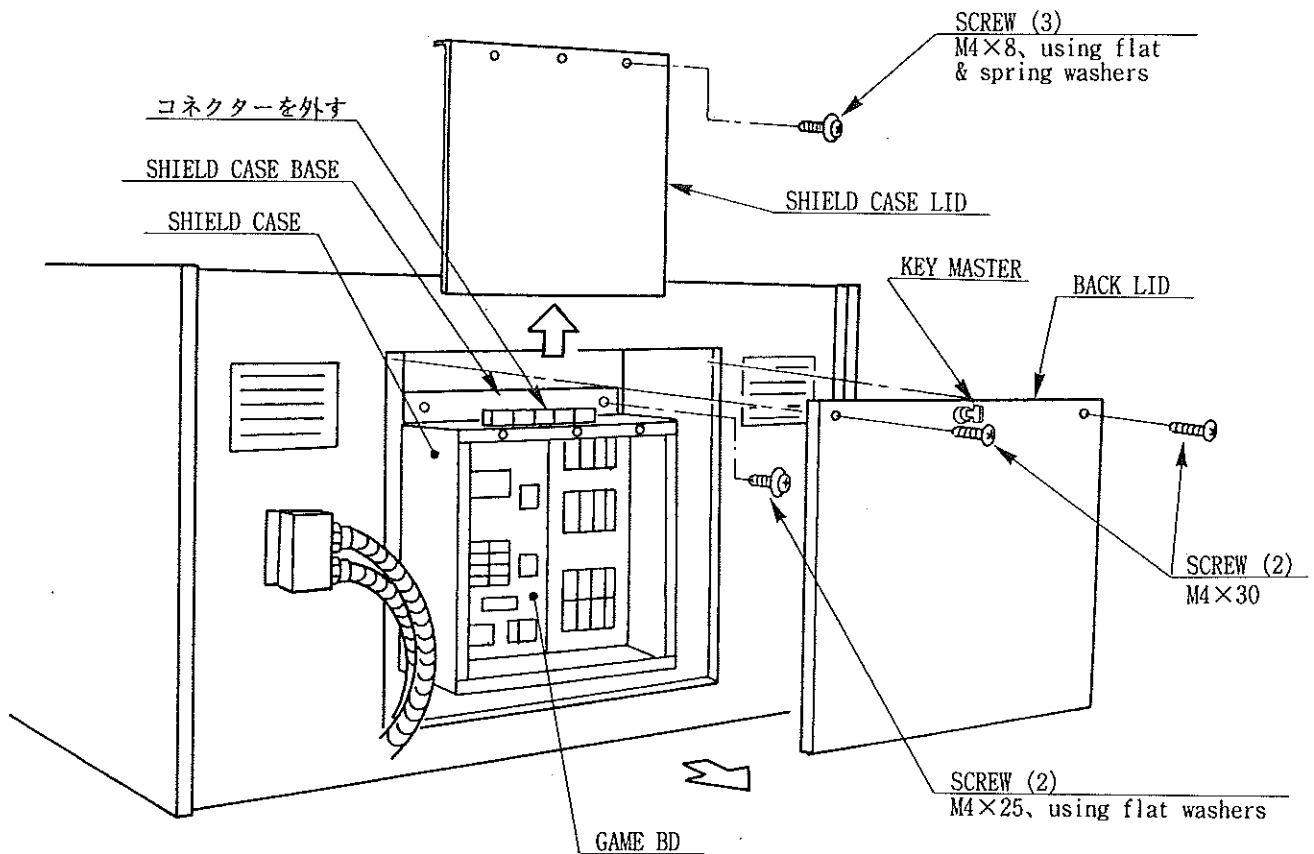

FIG. 15.1

15-2 COMPOSITION OF GAME BOARD

GAME BD VIRTUA COP 2 (833-12266)

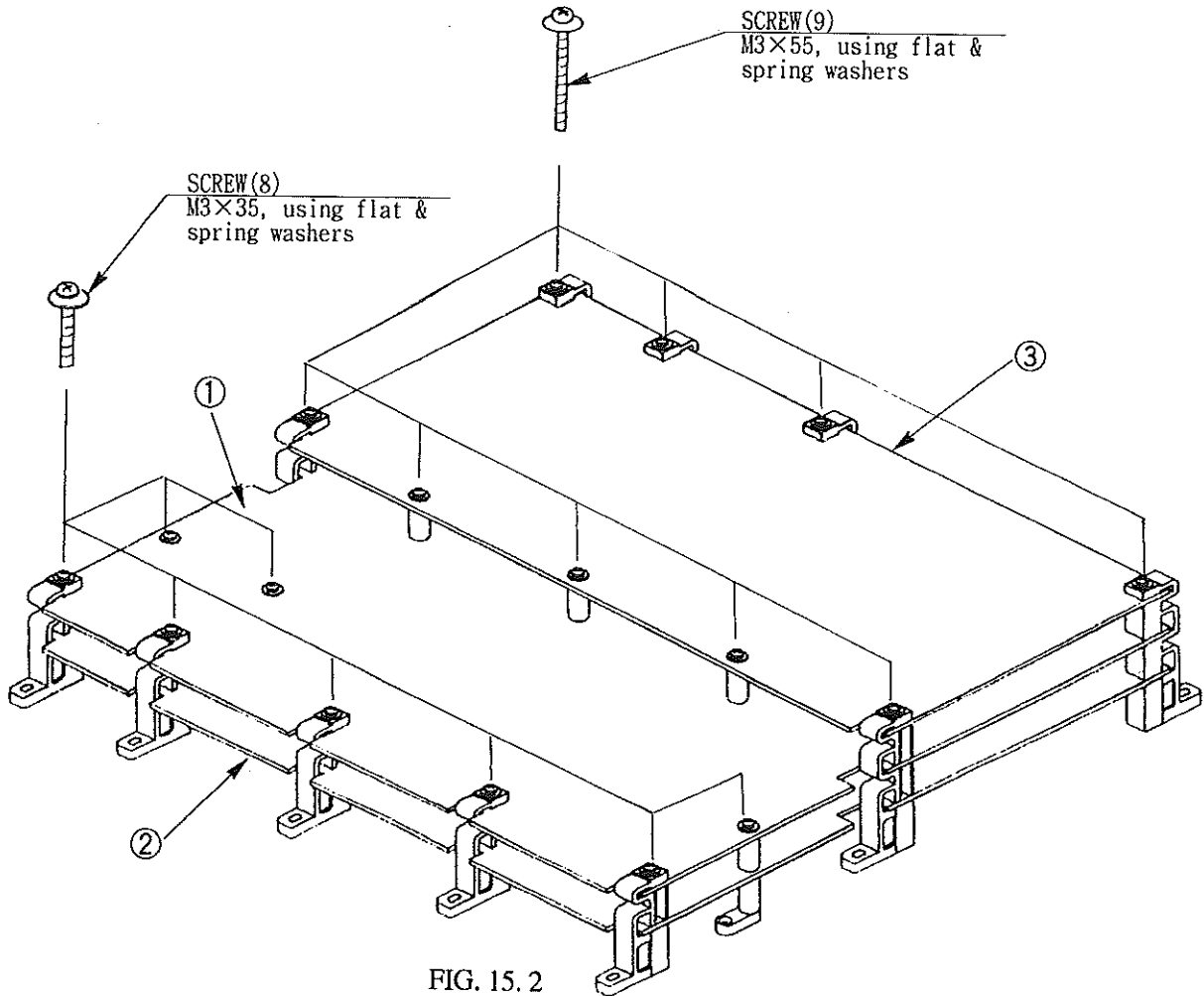
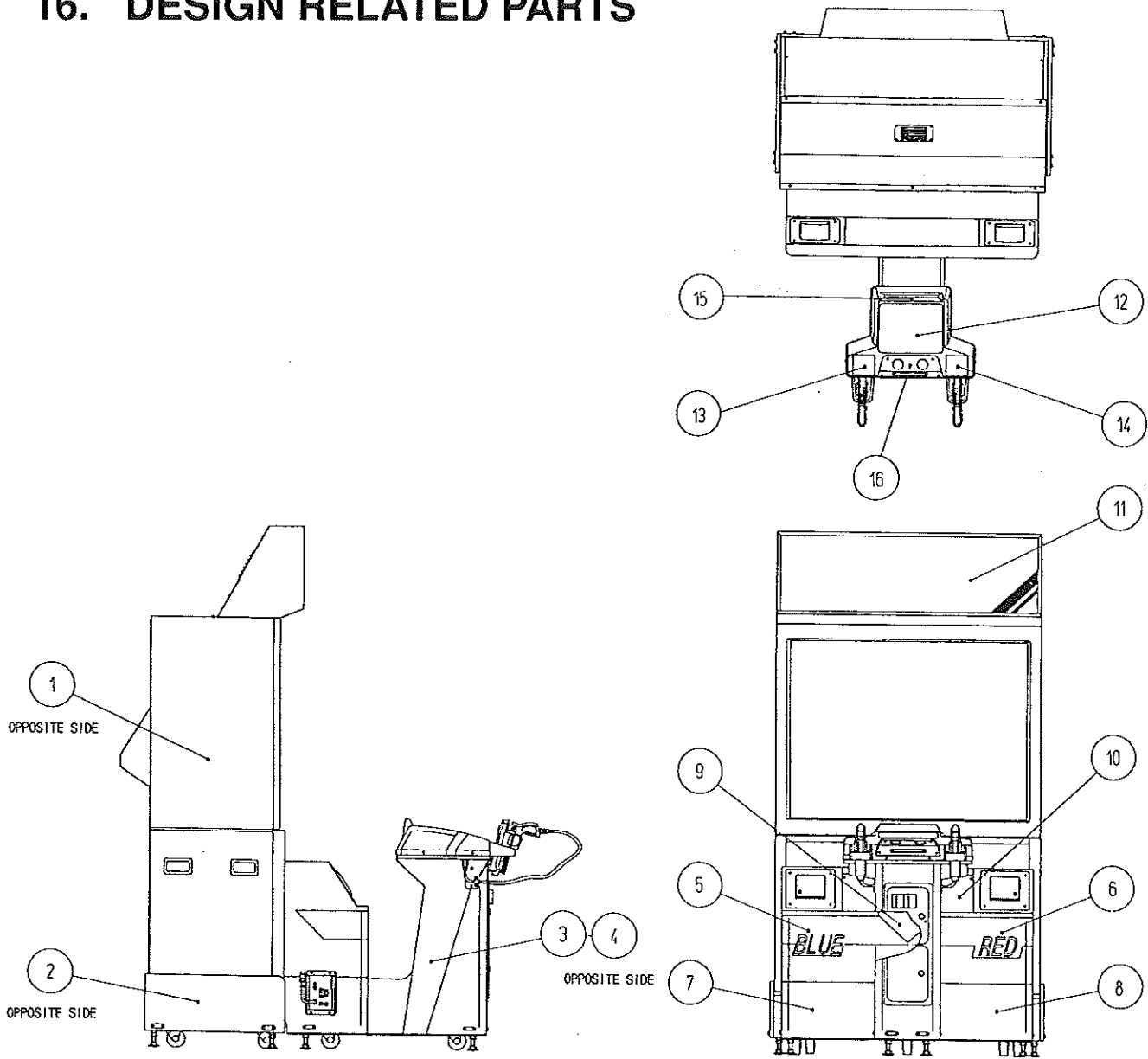

FIG. 15.2

No.	PART No.	DESCRIPTION
1	837-10848-91	MODEL2 A-CRX CPU BD COM
	837-10848-01-91	MODEL2 A-CRX CPU BD COM
2	837-10849-01	MODEL2 A-CRX VIDEO BD COM
	837-10849-02	MODEL2 A-CRX VIDEO BD COM
3	834-12267	ROM BD VIRTUA COP 2

# 16. DESIGN RELATED PARTS



No.	PART No.	Q/U	DESCRIPTION
1	421-8947	2	STICKER SIDE TV
2	CPT-1102	2	STICKER PTV BASE RIGHT
3	CPT-1025	1	STICKER TOWER LEFT
4	CPT-1026	1	STICKER TOWER RIGHT
5	CPT-1023	1	STICKER LEFT
6	CPT-1024	1	STICKER RIGHT
7	CPT-1028	1	STICKER UNDER LEFT
8	CPT-1029	1	STICKER UNDER RIGHT
9	CPT-1030	1	STICKER CENTER MARK
10	CPT-1027	1	STICKER GUARDAIN
11	CPT-1301	1	BILLBOARD
12	CPT-2004	1	INST PLATE
13	CPT-2001-C	1	STICKER OFFICER BLUE
14	CPT-2001-D	1	STICKER OFFICER RED
15	CPT-2001-B	1	STICKER VIRTUA COP 2
16	CPT-2002	1	BUTTON SHEET

# 17. PARTS LIST

① TOP ASSY VIRTUA COP 2 DX

(D-1/2)

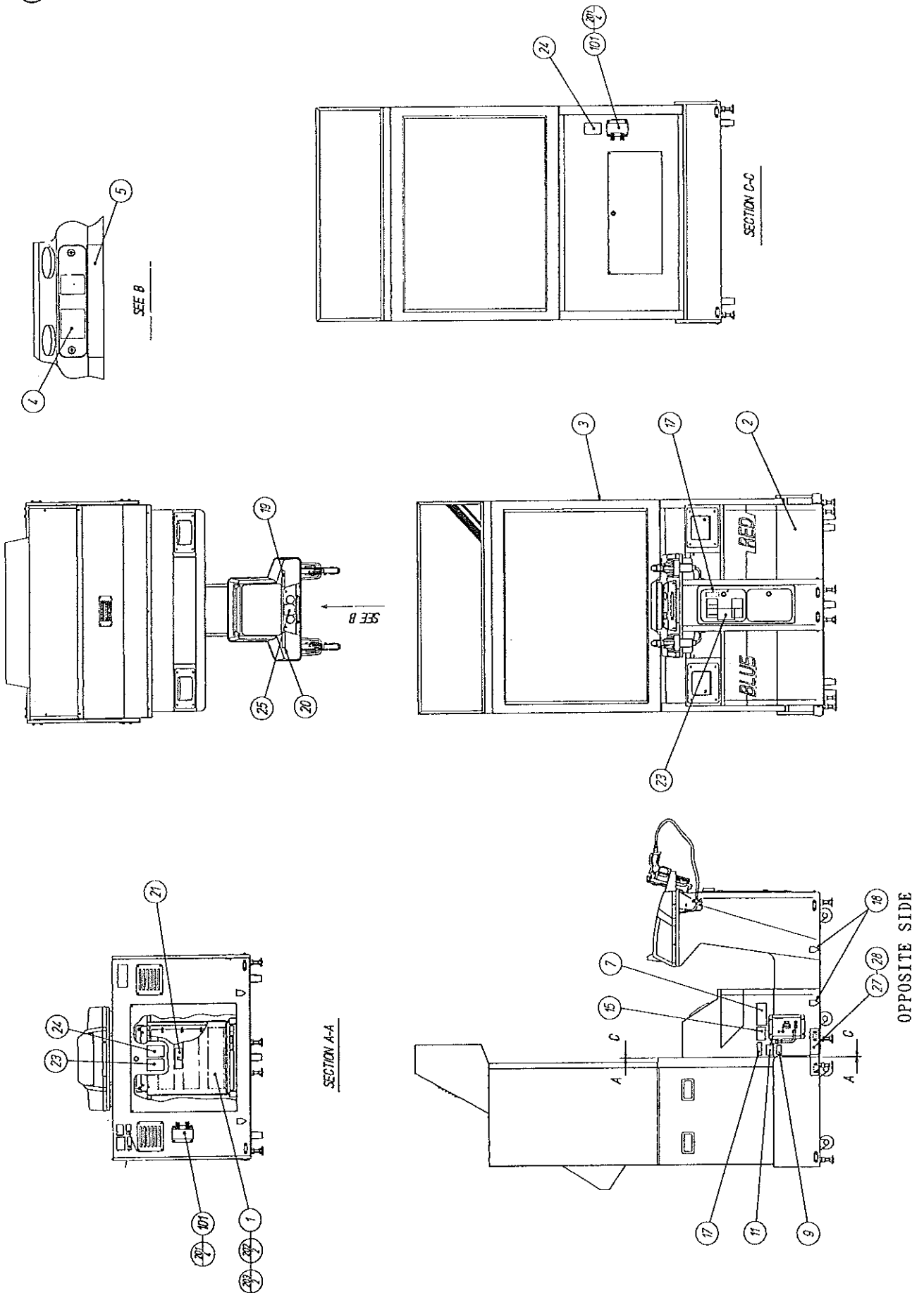

## ① TOP ASSY VIRTUA COP 2 DX (CPT-0000)

(D-2/2)

ITEM NO.	PART NO.	DESCRIPTION	NOTE
1	CPT-0100	ASSY SHIELD CASE DX	
2	CPT-1000	ASSY CABINET DX	
3	CPT-1100	ASSY PTV	
4	421-7308~	DENOMINATION SHEET 1GAME ~	OTHERS
	421-7308-55	NOT USED	NON DENOMI
9	421-6594-91	STICKER CERTIFICATE	
13	SGM-4111	KEY BAG	
14	220-5381	KEY MASTER FOR 220-5380	
15	421-7987	STICKER BLEC SPEC	OTHERS
	421-8408	STICKER BLEC SPEC FOR TAIWAN	TAIWAN
16	SGM-4385	POLY COVER 1000×1100×1000	
17	421-7988-91	STICKER SERIAL NUMBER	
18	421-7020	STICKER CAUTION FORK	
21	421-6709	STICKER SERVICE INSTRUCTION ENG	
22	421-8479-01	STICKER INSTR SUNLIGHT ENG	
23	440-WS0001-EG	STICKER W NOT OPEN DOOR ENG	
24	440-WS0002-EG	STICKER W POWER OFF ENG	
25	440-CS0018-EG	STICKER C CPT DX ENG	
26	421-8975	ADJ INSTR SH PTV	
27	CPT-0001	JOINT BRKT L	
28	CPT-0002	JOINT BRKT R	
29	440-WS0023-EG	STICKER W CPT DX A ENG	
101	600-6445-63	WIRE HARN CONNECT TUBE	
201	000-T00416-0B	M SCR TH BLK M4×16	
202	000-P00425	M SCR PH M4×25	
203	068-441616	FLT WSHR 4. 4-16×1. 6	
401	601-6604-70	CARTON BOX 70	
402	SGM-2675	POLYETHYLENE BAG 240×370	
403	540-0006-01	WRENCH FOR TAMP PRF SCR DUAL TYPE M4	
405	420-6195-02	OWNERS MANUAL VIRTUA COP 2 DX ENG	
407	601-6605-04	CARTON BOX 600×460×70	
408	600-6664-02	WIRE HARN BARTH W/LUG M6	
409	390-5160	LAMP WEDGE BASE TYPE 6V 3W	
410	509-5080	SW MICRO TYPE	
/	105-5216	CHAIN BRKT	
/	601-7975	CHAIN 1080	
/	GPD-0002X	SHIPPING BRACKET	
/	421-8740	CAUTION INSTR COP U/R	
/	560-5212	STEP DN AUTO XFMR 550VA	
/	CPT-1461	WOODEN BASE XFMR	
/	000-P00516-W	M SCR PH W/FS M5×16	
/	000-P00430	M SCR PH M4×30	
/	068-441616	FLT WSHR 4. 4-16×1. 6	
/	600-6656-43	WIRE HARN AUTO XFMR	
/	008-T00408-0C	TMP PRF SCR TH CRM M4×8	
/	421-6690~	STICKER ~V	
/	600-6618	AC CABLE CONECT TYPE FOR EXP	OTHERS
/	600-6619	AC CABLE CONECT TYPE FOR UK	U. K.



② ASSY SHIELD CASE DX (CPT-0100)

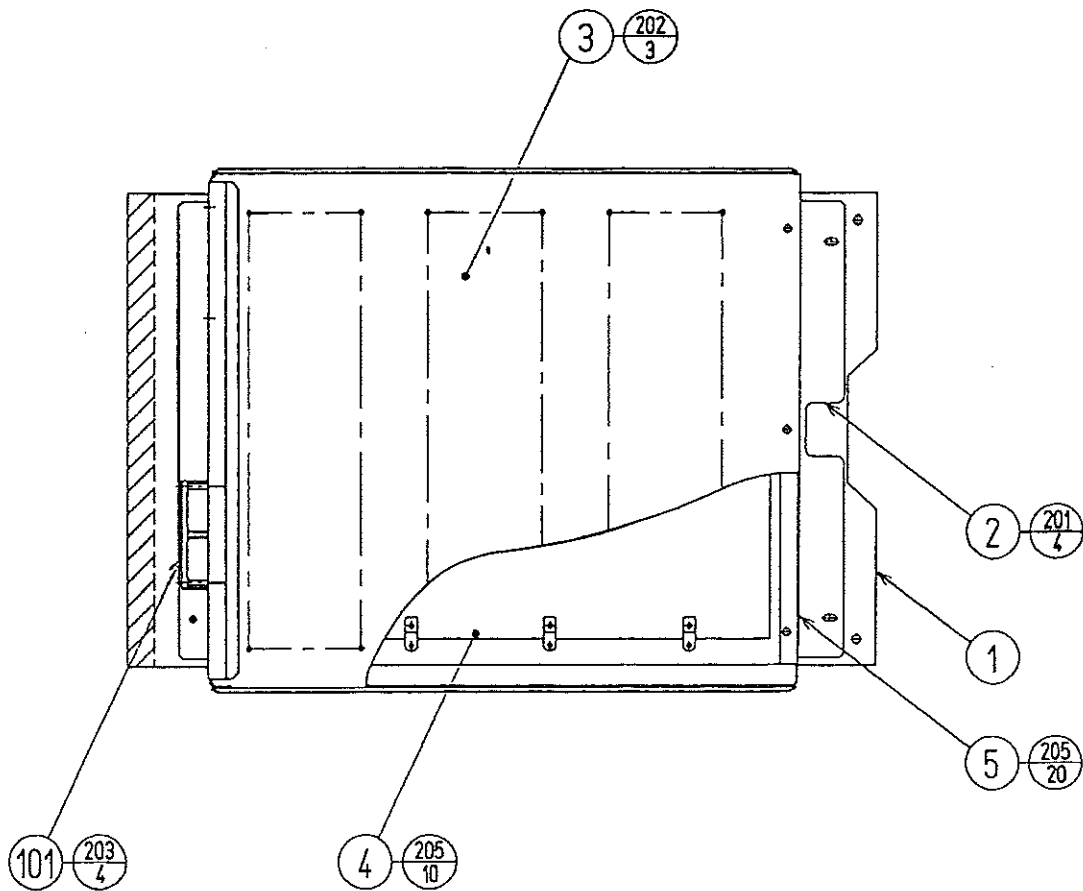

ITEM NO.	PART NO.	DESCRIPTION	NOTE
1	CPT-0101	SHIELD CASE BASE	
2	105-5218	SHIELD CASE	
3	105-5219-91	SHIELD CASE LID	
4	833-12266	GAME BD VIRTUA COP 2	
5	839-0827	FLT BD A-CRX COP2	
101	260-0055	FAN MOTOR DC5V	
102	209-0023	CONN CLOSED END	
103	601-0460	PLASTIC TIE BELT 100MM	
105	280-0425	CORD CLAMP $\phi$ 10	
201	000-P00414-W	M SCR PH W/FS M4 $\times$ 14	
202	000-P00408-W	M SCR PH W/FS M4 $\times$ 8	
203	000-P00330-W	M SCR PH W/FS M3 $\times$ 30	
204	011-F00310	TAP SCR FH 3 $\times$ 10	
205	010-P00308-F	S-TITE SCR PH W/F M3 $\times$ 8	
301	600-6502-13	WIRE HARN DC FAN	
302	600-6656-22	WIRE HARN DC GAME BD	
303	600-6656-23	WIRE HARN RGB GAME BD	
304	600-6656-24	WIRE HARN COMM GAME BD	
305	600-6656-25	WIRE HARN AUDIO GAME BD	
306	600-6656-26	WIRE HARN MAIN GAME BD	

③ ASSY CABINET DX (CPT-1000)

(D-1/2)

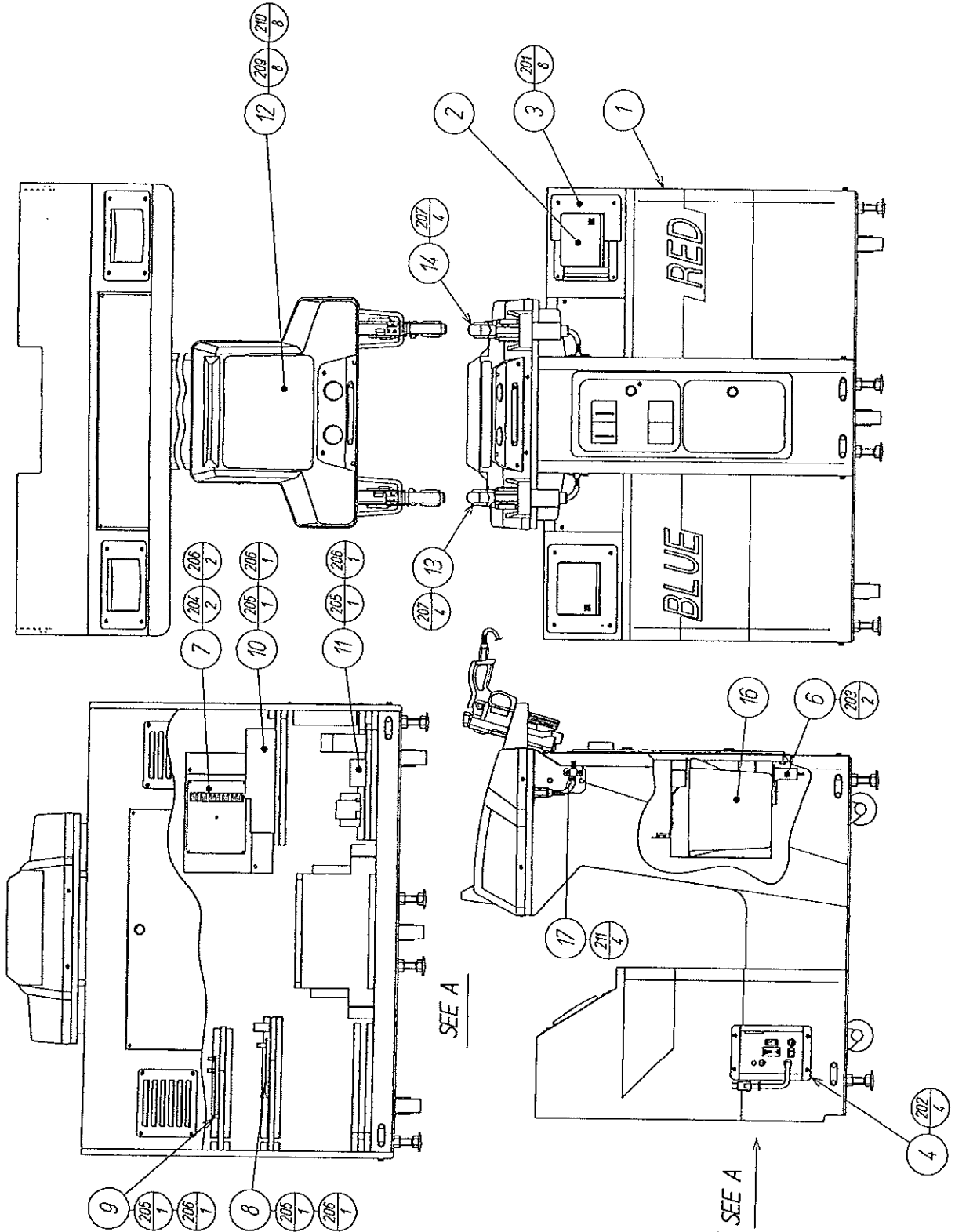

③ ASSY CABINET DX (CPT-1000)

(D-2/2)

ITEM NO.	PART NO.	DESCRIPTION	NOTE
1	CPT-1001	ASSY SUB CABI DX	
2	CPT-1060	ASSY SPEAKER	
3	CPT-1011	SPEAKER COVER	
4	CPT-1070	AC UNIT	
	CPT-1070-01	AC UNIT EXP	TAIWAN OTHERS
6	COP-1590	METER UNIT	
7	CPT-1400	ASSY AMP BD	
8	CPT-1410	ASSY BUFFER BD	
9	CPT-1420	ASSY I/O BD	
10	CPT-1430	ASSY SW REGU	
11	CPT-1440	ASSY AC SPLY	
12	CPT-2000	ASSY CONT PANEL DX	
13	COP-2000	CONTROL UNIT 1P	
14	COP-2050	CONTROL UNIT 2P	
16	253-5366	CASH BOX	
17	CPT-1017	CABLE CLAMP	
201	008-T00420-0B	TMP PRF SCR TH BLK M4×20	
202	000-T00420-0C	M SCR TH CRM M4×20	
203	000-P00410-W	M SCR PH W/FS M4×10	
204	032-000430	WING BLT M4×30	
205	000-P00430	M SCR PH M4×30	
206	068-441616	FLT WSHR 4, 4-16×1, 6	
207	008-T00430-0C	TMP PRF SCR TH CRM M4×30	
209	008-T00416-0C	TMP PRF SCR TH CRM M4×16	
210	068-441616-0C	FLT WSHR CRM 4, 4-16×1, 6	
211	000-T00410-0C	M SCR TH CRM M4×10	
301	600-6656-07	WIRE HARN SW REGU AC IN	

④ ASSY SUB CABI DX (CPT-1001)

(D-1/3)

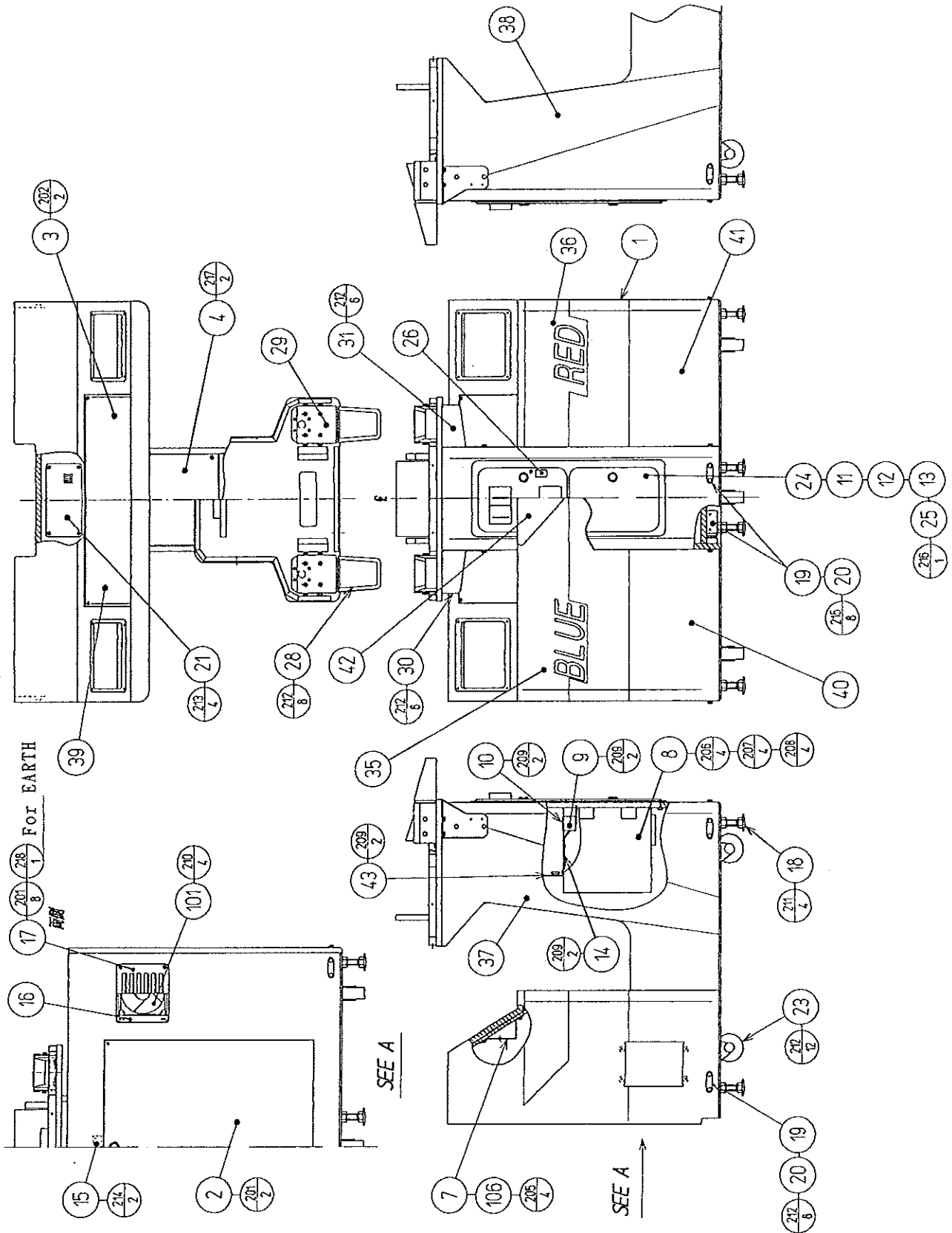

## ④ ASSY SUB CABI DX (CPT-1001)

(D-2/3)

ITEM NO.	PART NO.	DESCRIPTION	NOTE
1	CPT-1002	WOODEN FRONT CABINET	
2	CPT-1050	ASSY BACK LID	
3	CPT-1003	MAINTENANCE LID UPPER	
4	CPT-1004	MAINTENANCE LID LOWER	
7	CPT-1012	SHIELD CASE BASE MOUNT BRKT	
8	105-5106	CASH BOX COVER	OTHERS
	105-5109	COVER CASH BOX MARS	FOR MARS
9	105-5107	CHUTE	OTHERS
	105-5110	LOWER COIN CHUTE MARS	FOR MARS
11	DP-1167	TNG LKG	
		NOT USED	FOR MARS
12	220-5380	MAGNETIC LOCK MASTER W/O KEY	
		NOT USED	FOR MARS
13	220-5046-91	MAGNETIC LOCK W/KEYS	
		NOT USED	FOR MARS
14	105-5170	LOCK BRACKET S	
15	117-5098	TNG RETAINBR PLATE	
16	HN-1042X	FAN BRKT	
17	UP-1018	AIR VENT	
18	601-5699X	LEG ADJUSTER BOLT M16×75	
19	ARC-1006	LEG BRKT	
20	117-5191	PLATE	
21	117-5279	GUARD PLATE 96×196	
23	601-6224	CASTER φ75	
24	220-5128-~	ASSY COIN CHUTE 2DOOR ~	OTHERS
	220-5374	DOUBLE DOOR FRAME W/CASH DOOR	FOR MARS
25	421-7501-02	STICKER 6.3V 0.15A	OTHERS
		NOT USED	FOR MARS
28	CPT-1019	HOLDER	
29	CPT-1020	HOLDER BRKT	
30	CPT-1021	SIDE BRKT L	
31	CPT-1022	SIDE BRKT R	
34	CPT-1450	ASSY WIRE DX	
35	CPT-1023	STICKER LBFT	
36	CPT-1024	STICKER RIGHT	
37	CPT-1025	STICKER TOWER LEFT	
38	CPT-1026	STICKER TOWER RIGHT	
39	CPT-1027	STICKER GUARDAIN	
40	CPT-1028	STICKER UNDER LEFT	
41	CPT-1029	STICKER UNDER RIGHT	
42	CPT-1030	STICKER CBNTER MARK	
43	CPT-1080	SW UNIT	
101	260-0011-02	AXIAL FLOW FAN AC100V 50-60Hz	
103	280-5009-01	CORD CLAMP φ21	
104	280-0425	CORD CLAMP φ10	
105	310-5029-F20	SUMITUBE F F20MM	OTHERS
		NOT USED	FOR MARS
106	280-5190-02	EDGE SADDLE ES-1916	
201	000-T00430-0B	M SCR TH BLK M4×30	
202	000-T00430-0C	M SCR TH CRM M4×30	

④ ASSY SUB CABI DX (CPT-1001)

(D-3/3)

ITEM NO.	PART NO.	DESCRIPTION	NOTE
205	000-P00412-W	M SCR PH W/FS M4×12	
206	000-P00406	M SCR PH M4×6	
207	060-S00400	SPR WSHR M4	
208	060-F00400	FLT WSHR M4	
209	000-P00410-W	M SCR PH W/FS M4×10	
210	000-P00312	M SCR PH M3×12	
211	050-H01600-0B	HEX NUT M16 BLK	
212	030-000630-SC	HEX BLT W/S CRM M6×30	
213	000-T00420-0B	M SCR TH BLK M4×20	
214	011-T00312	TAP SCR TH 3×12	
215	030-000650-SC	HEX BLT W/S CRM M6×50	
216	000-P00430	M SCR PH M4×30	
217	000-T00440-0C	M SCR TH CRM M4×40	
218	050-F00400	FLG NUT M4	
219	011-F00312	TAP SCR FH 3×12	
301	600-6656-06	WIRE HARN AC FAN	
302	600-6455-02	WIRE HARN COIN CHUTE DOOR SINGLE	OTHERS FOR MARS
	600-6455-04	WIRE HARN MARS MS-111	
303	600-6455-03	WIRE HARN EARTH	
304	600-6656-28	WIRE HARN EARTH AC FAN	
305	600-6656-29	WIRE HARN EARTH SP. L	
306	600-6656-30	WIRE HARN EARTH SP. R	
307	600-6656-31	WIRE HARN EARTH SW UNIT	
/	HN-1050	SPACER RING	} OTHERS  FOR MARS
/	109-0045-91	KEY HOLDER	
/	105-5201	MAGNETIC LOCK BRKT FOR ASAHI	
/	600-6455-01	WIRE HARN COIN CHUTE DOOR TWIN	
/	600-6455-03	WIRE HARN EARTH	
/	600-6455-07	WIRE HARN METER GND BK	
/	000-P00308-W	M SCR PH W/FS M3×8	
/	600-6455-06	WIRE HARN METER GND WH	

⑤ ASSY BACK LID (CPT-1050)

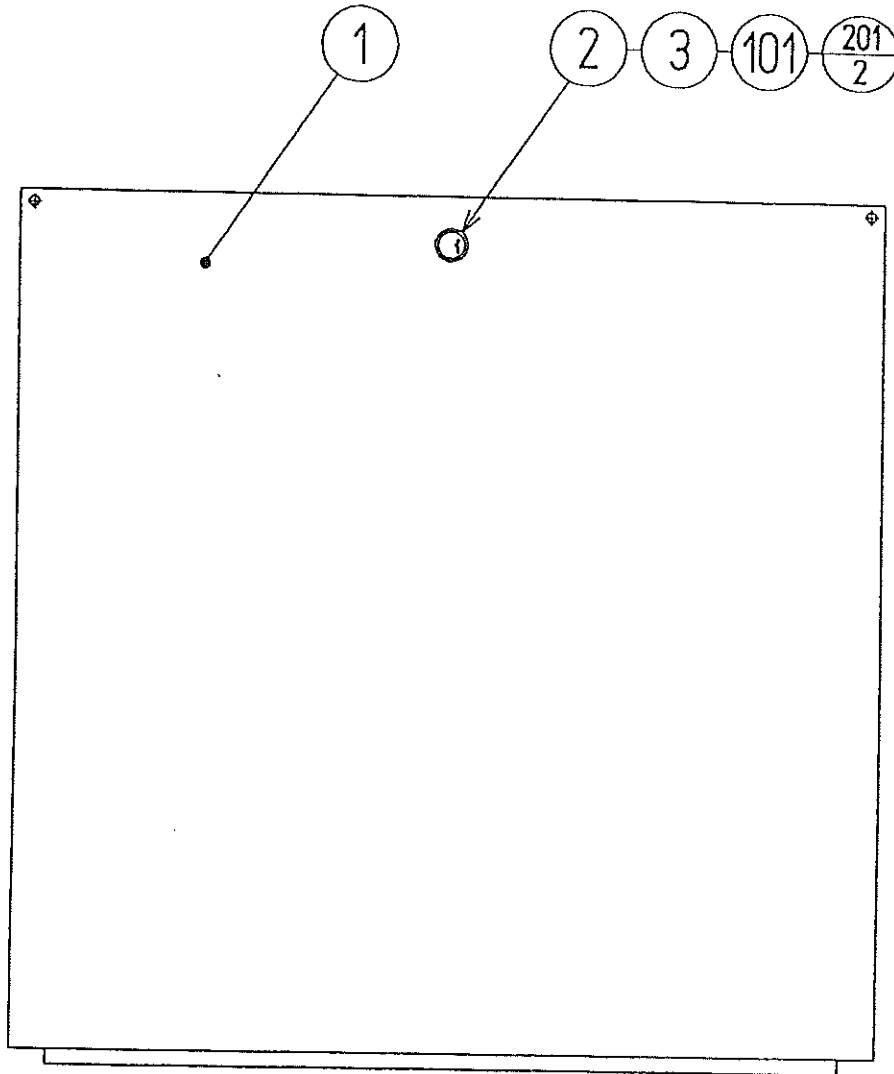

ITEM NO.	PART NO.	DESCRIPTION	NOTE
1	CPT-1005	MAINTENANCE LID BACK	
2	DP-1148X	LKG TNG	
3	117-0062	PLATE LOCK RETAINER	
101	220-5380	MAGNETIC LOCK MASTER W/O KEY	
201	011-T00312	TAP SCR TH 3×12	

⑥ ASSY SPEAKER (CPT-1060)

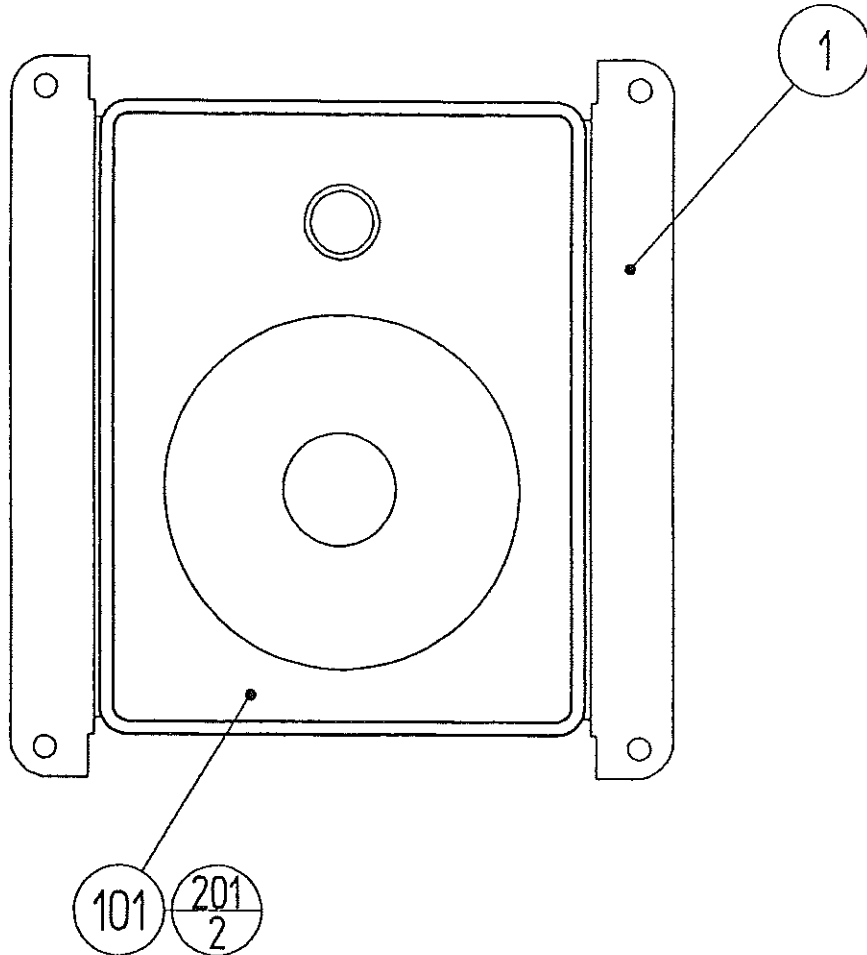

ITEM NO.	PART NO.	DESCRIPTION	NOTE
1	CPT-1061	SPEAKER BRKT	
101	130-5096	ASSY SERVO SPEAKER BOX	
201	000-P00512-W	M SCR PH W/FS M5×12	
301	600-6341-44	WIRE HARN RIGHT SPEAKER	
302	600-6656-32	WIRE HARN EARTH SPEAKER	



⑦ AC UNIT (CPT-1070)

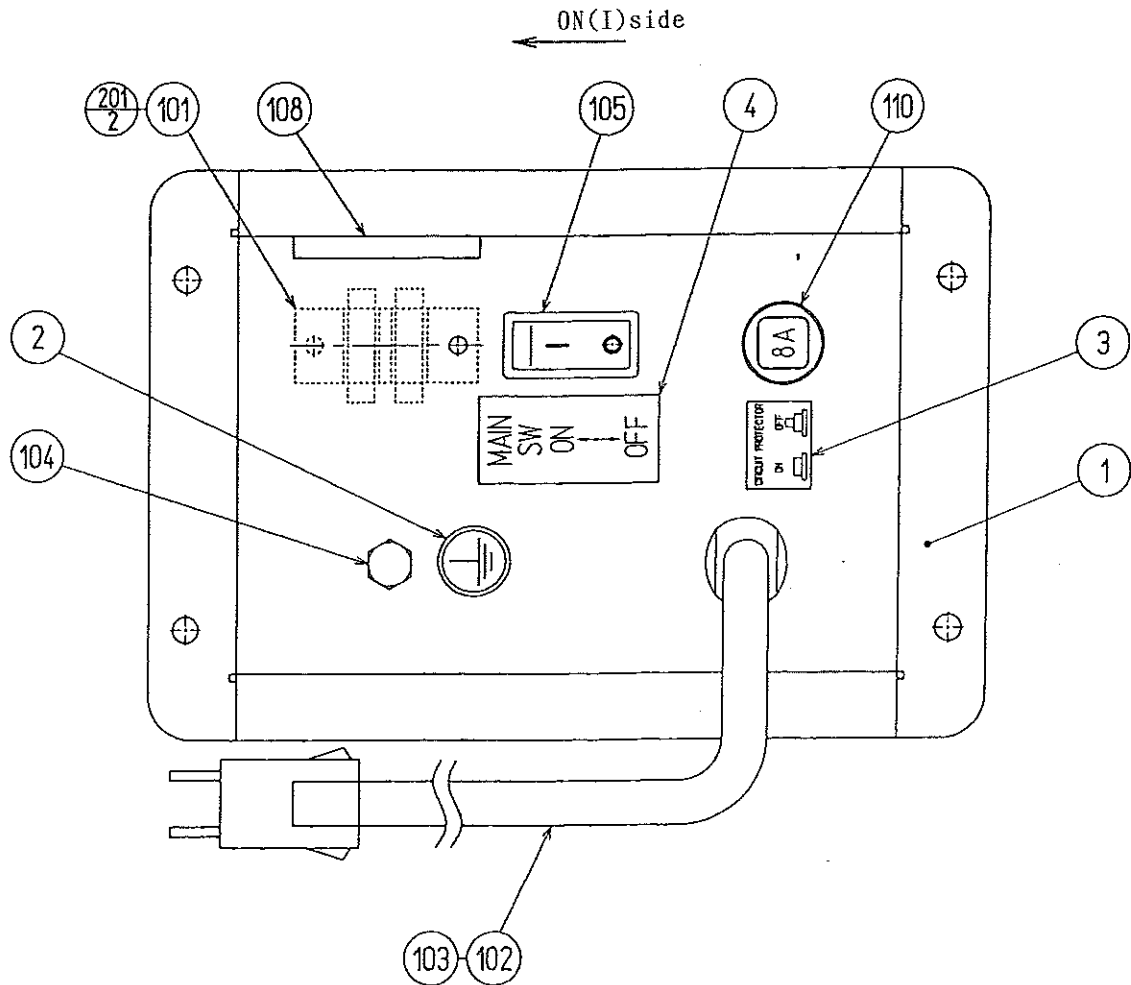

ITEM NO.	PART NO.	DESCRIPTION	NOTE
1	CPT-1071	AC BRKT	
2	421-8202	STICKER EARTH MARK	
3	421-7468	STICKER C.P	
4	421-6526	STICKER ON OFF	
101	117-5182	TERMINAL PLATE 2P	
102	600-5843-25	CA & PLUG ASSY 15A W/-F- L=2.5M	
103	280-5134-6N34	BUSHING STRAIN RELIEF 6N34	
104	280-0417	TERMINAL BINDING POST BLACK	
105	509-5453-V-B	SW ROCKER J8 V-B	
106	209-0023	CONN CLOSED END	
107	601-0460	PLASTIC TIE BELT 100MM	
108	253-5185	CAP SW 30	
109	280-5008	CORD CLAMP $\phi$ 15	
110	512-5033-8000	CIRCUIT PROTECTOR 8000mA	
201	010-P00312-F	S-TITE SCR PH W/F M3×12	
301	600-6656-01	WIRE HARN AC IN	
302	600-6656-02	WIRE HARN MAIN SW	
303	310-5029-H20	SUMITUBE F H20MM	

⑦ AC UNIT EXP (CPT-1070-01)

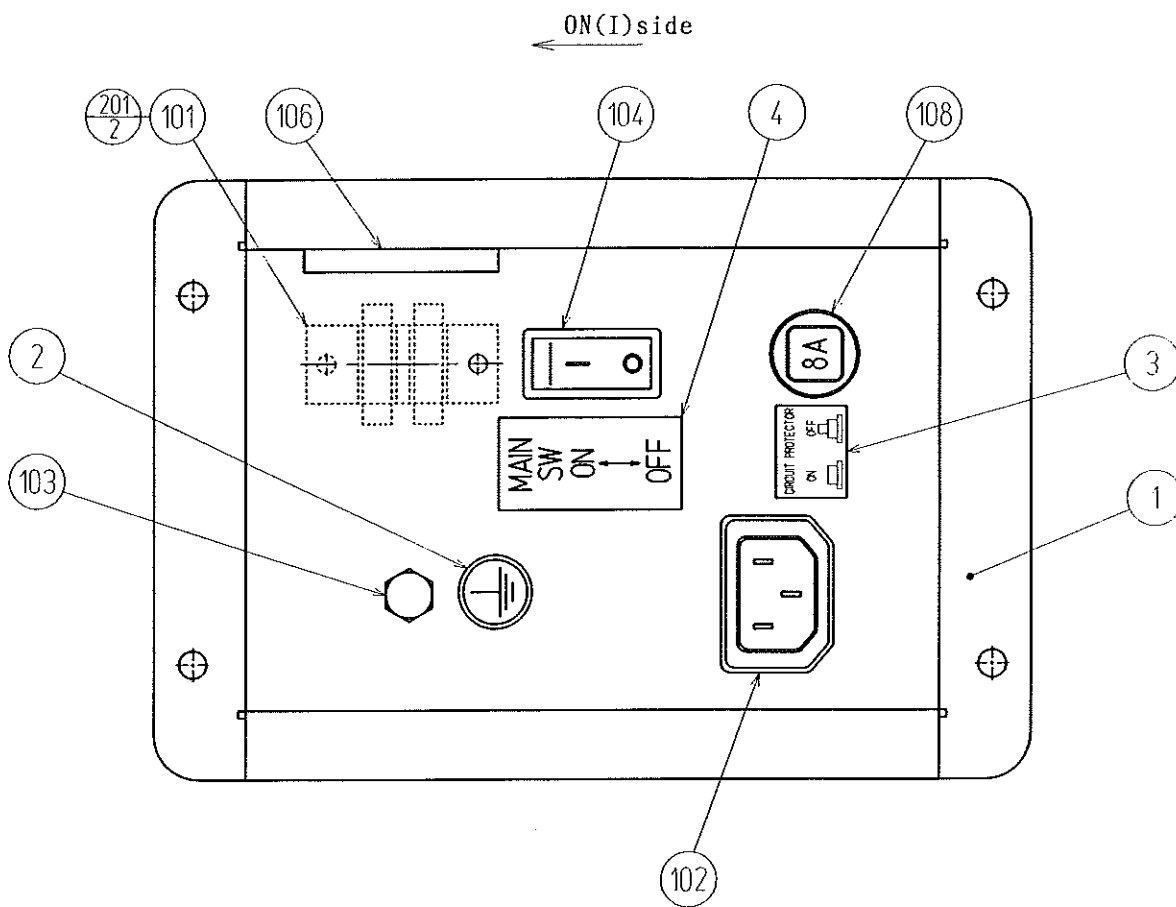

ITEM NO.	PART NO.	DESCRIPTION	NOTE
1	CPT-1071-01	AC BRKT EXP	
2	421-8202	STICKER EARTH MARK	
3	421-7468	STICKER C. P	
4	421-6526	STICKER ON OFF	
101	117-5182	TERMINAL PLATE 2P	
102	214-0202	AC INLET PANEL TYPE	
103	280-0417	TERMINAL BINDING POST BLACK	
104	509-5453-V-B	SW ROCKER J8 V-B	
105	601-0460	PLASTIC TIE BELT 100MM	
106	253-5185	CAP SW 30	
108	512-5033-5000	CIRCUIT PROTECTOR 5000mA	
201	010-P00312-F	S-TITE SCR PH W/F M3×12	
301	600-6656-44	WIRE HARN AC IN EXP	
302	600-6656-02	WIRE HARN MAIN SW	
303	310-5029-H20	SUMITUBE F H20MM	

⑧ SW UNIT (CPT-1080)

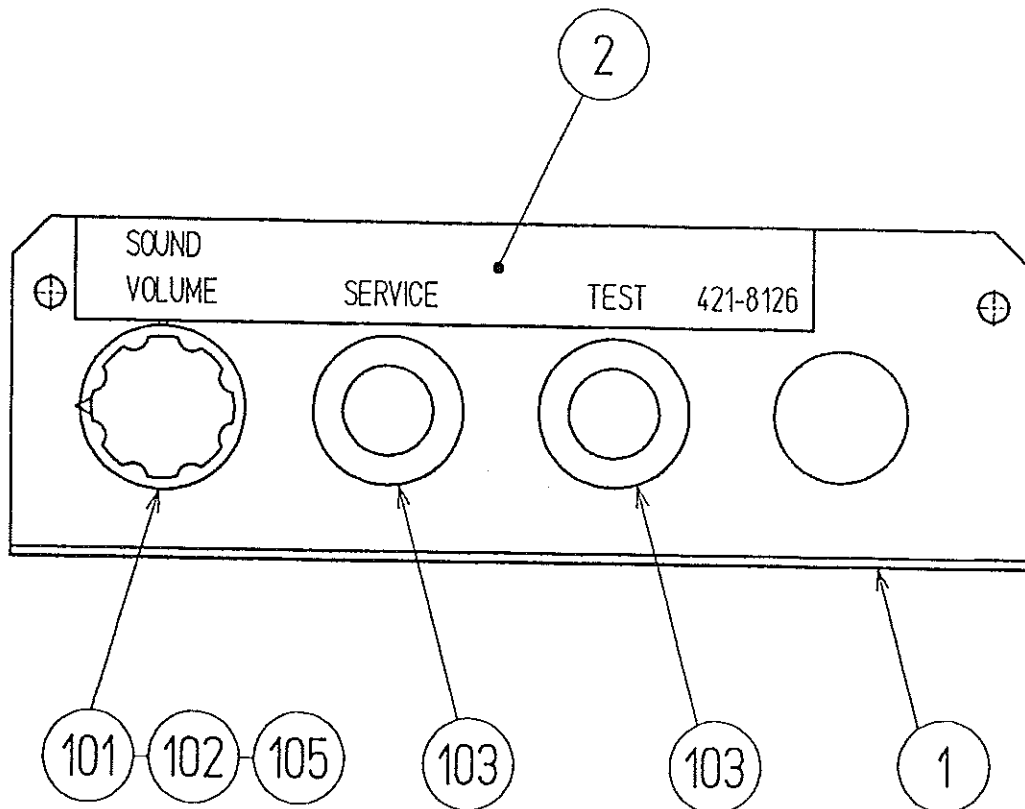

ITEM NO.	PART NO.	DESCRIPTION
1	KR-1060	SW BRKT
2	421-8126	STICKER SWITCH PANEL
101	220-5179	VOL CONT B-5K OHM
102	601-0042	KNOB 22mm
103	509-5028	SW PB 1M
104	601-0460	PLASTIC TIE BELT 100MM
105	310-5029-015	SUMITUBE F D15MM
301	600-6656-21	WIRE HARN SW UNIT

⑨ ASSY PTV (CPT-1100)

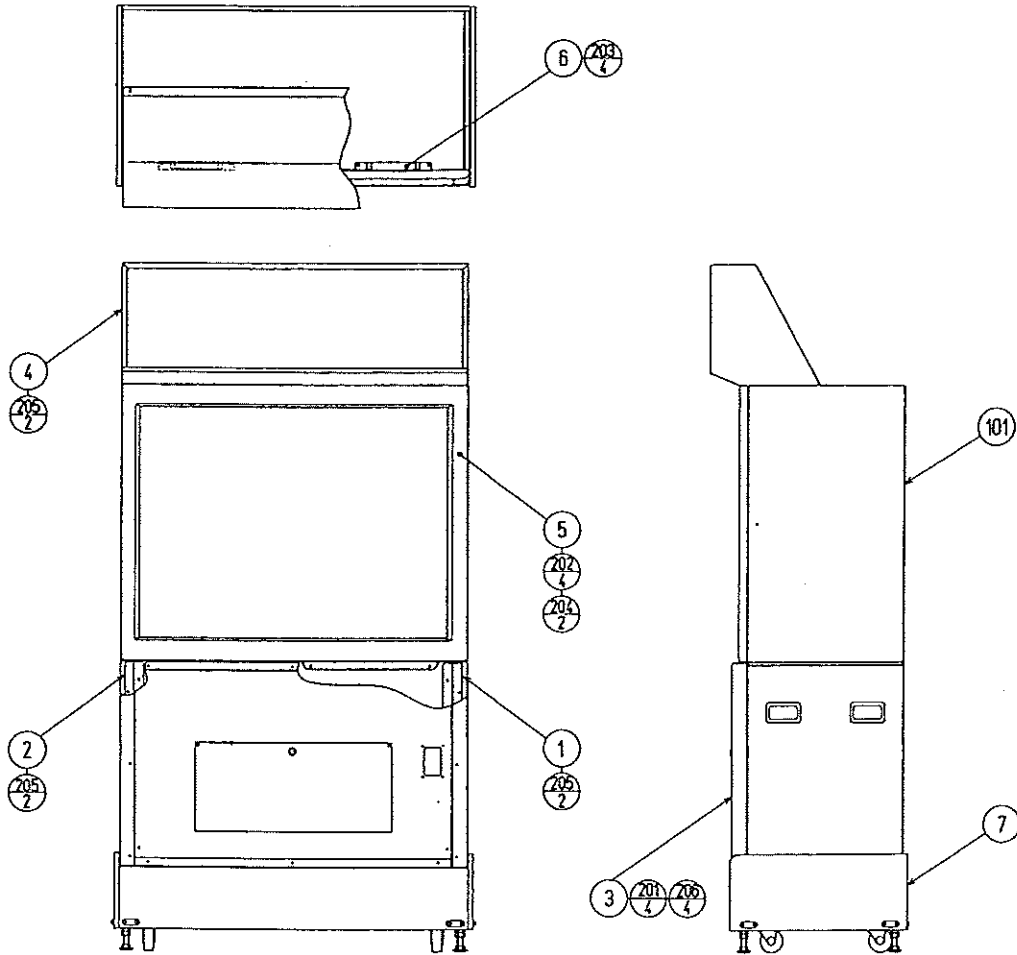

ITBM NO.	PART NO.	DESCRIPTION	NOTE
1	DYN-0501	PANEL MOUNT BRKT L	
2	DYN-0502	PANEL MOUNT BRKT R	
3	CPT-1200	ASSY FRONT PANEL	
4	CPT-1300	ASSY BILLBOARD	
5	MGL-1150	ASSY MASK	
6	RAL-0501	MASK HOLDER	
7	CPT-1101	PTV BASE	
101	200-5315-01-CPT	ASSY PROJECTION DISPLAY CPT (W/RC)	
201	000-T00520-0C	M SCR TH CRM M5×20	
202	000-T00520-0B	M SCR TH BLK M5×20	
203	000-F00414	M SCR PH M4×14	
204	000-T00525-0C	M SCR TH CRM M5×25	
205	000-P00516-W	M SCR PH W/FS M5×16	
206	068-552016-0C	FLT WSHR CRM 5.5-20×1.6	

⑩ ASSY MASK (MGL-1150)

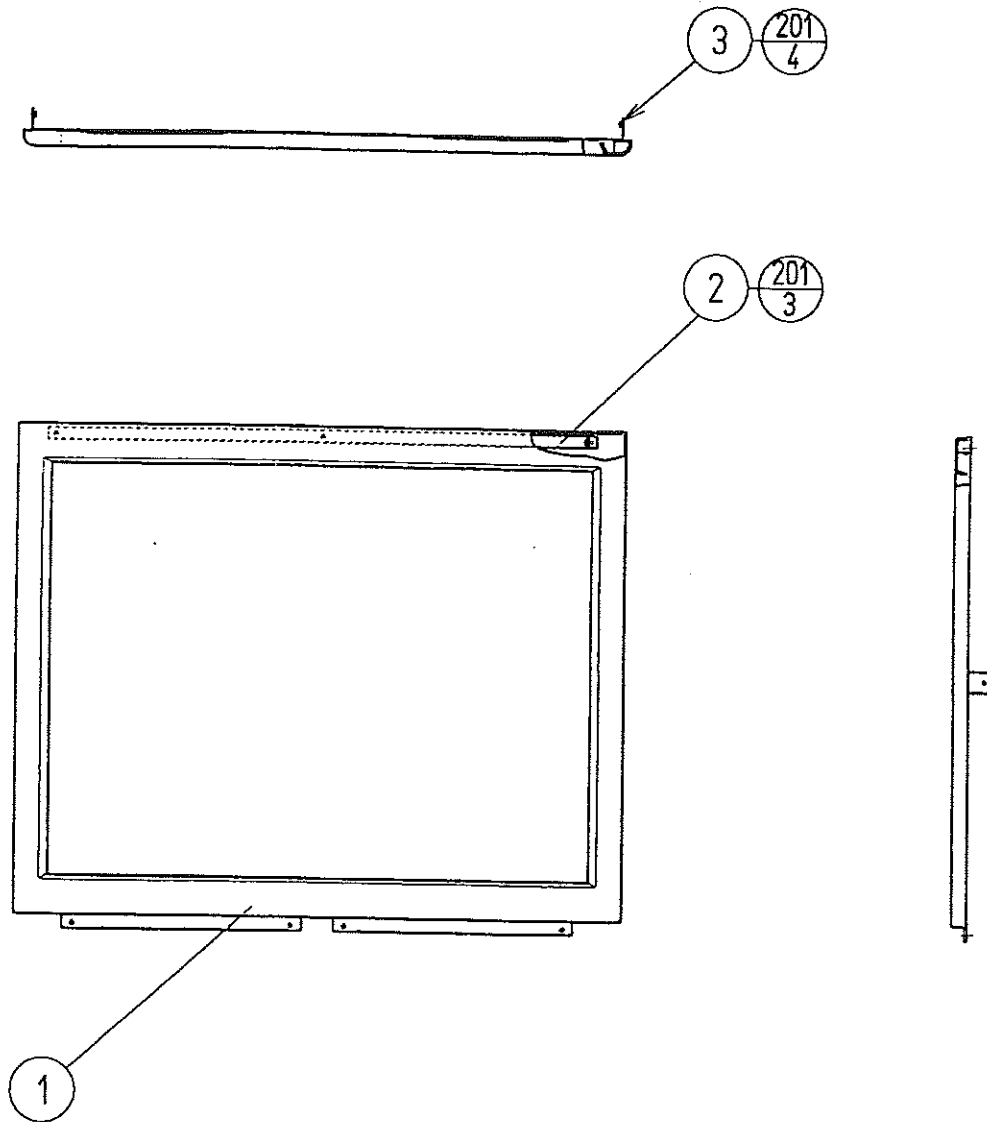

ITEM NO.	PART NO.	DESCRIPTION	NOTE
1	MGL-1102	TV MASK	
2	MGL-1151	SLIT PLATE	
3	MGL-1152	MASK SIDE HOLDER	
201	012-F00408-0B	TAP SCR FH BLK	
202	000-F00410	M SCR FH M4×10	

⑪ ASSY FRONT PANEL (CPT-1200)

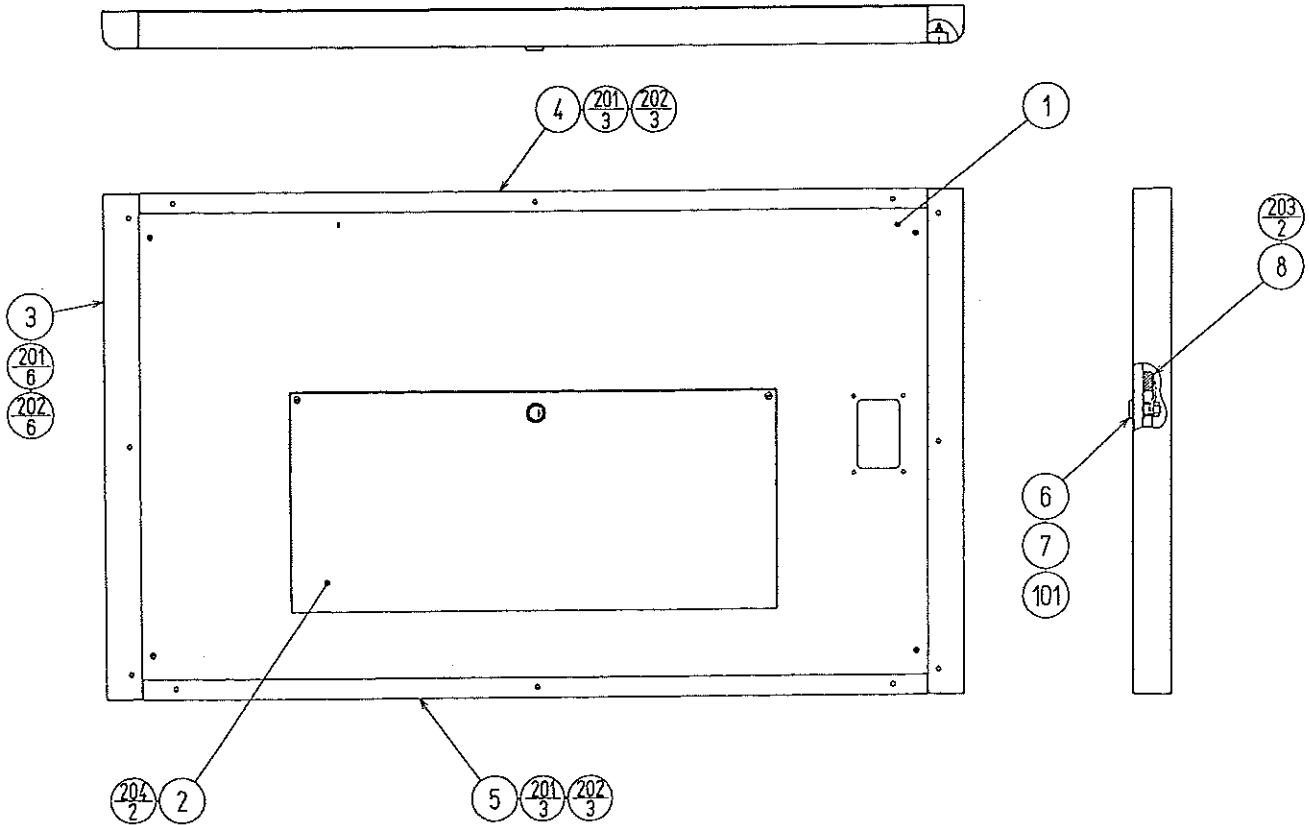

ITEM NO.	PART NO.	DESCRIPTION	NOTE
1	CPT-1201	FRONT PANEL	
2	CPT-1202	SERVICE DOOR	
3	CPT-1203	SIDE BRKT	
4	CPT-1204	BRKT UPPER	
5	CPT-1205	BRKT LOWER	
6	DP-1148X	LKG TNG	
7	117-0062	PLATE LOCK RETAINER	
8	117-5098	TNG RETAINER PLATE	
101	220-5380	MAGNETIC LOCK MASTER W/O KEY	
201	068-552016	FLT WSHR 5, 5-20×1, 6	
202	050-F00500	FLG NUT M5	
203	011-T00312	TAP SCR TH 3×12	
204	000-T00430-0C	M SCR TH CRM M4×30	

⑫ ASSY BILLBOARD (CPT-1300)

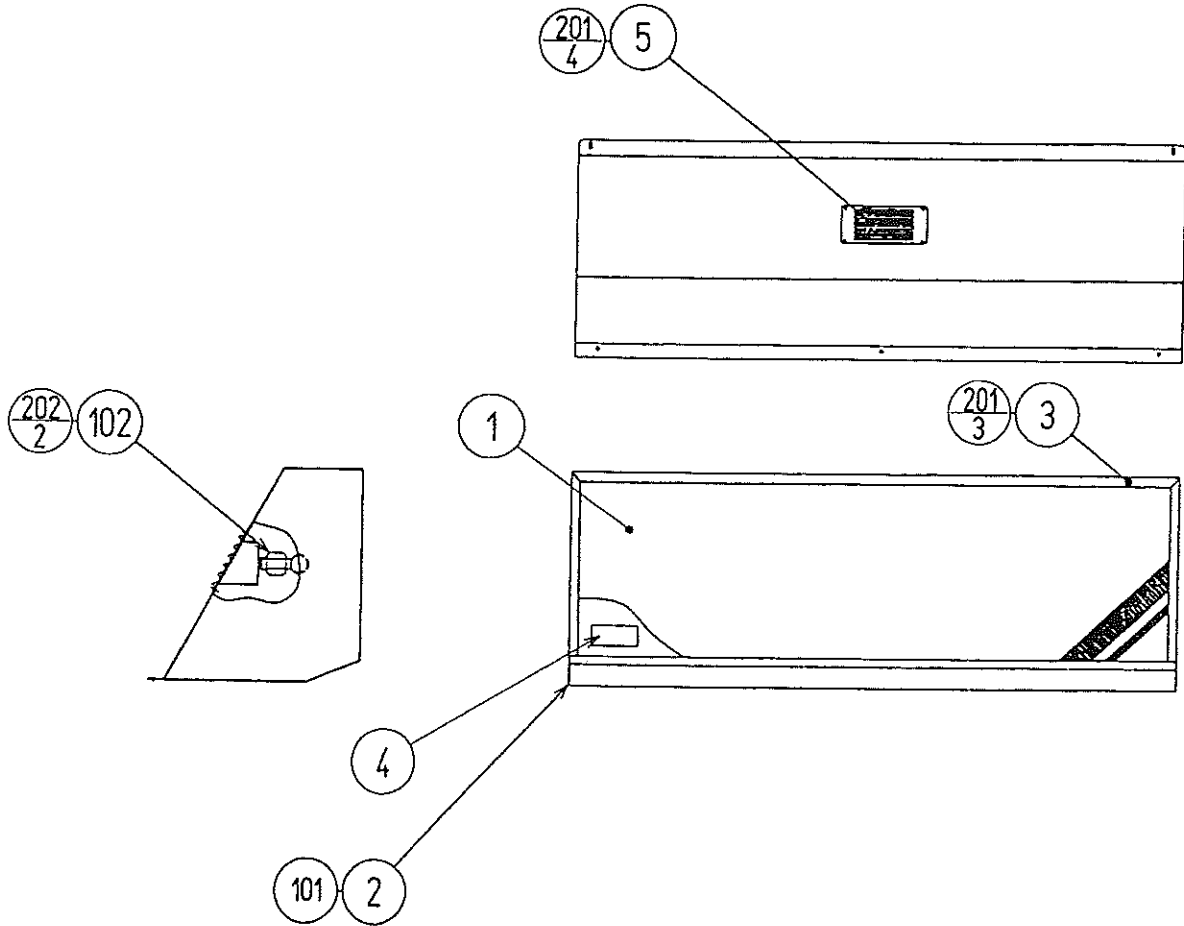

ITEM NO.	PART NO.	DESCRIPTION	NOTE
1	CPT-1301	BILLBOARD	
2	CPT-1302	BILLBOARD BOX	
3	CPT-1303	BILLBOARD HOLDER	
4	421-7501-18	STICKER FL32W	
5	UP-1018	AIR VENT	
101	280-5009	CORD CLAMP $\phi$ 21	
102	390-5538-32EX	ASSY FL32W EX W/CONN HIGH	
201	000-T00408-0B	M SCR TH BLK M4 $\times$ 8	
202	000-P00416-W	M SCR PH W/FS M4 $\times$ 16	
301	600-6445-46-91	WIRE HARN BILLBOARD	

⑬ ASSY AMP BD (CPT-1400)

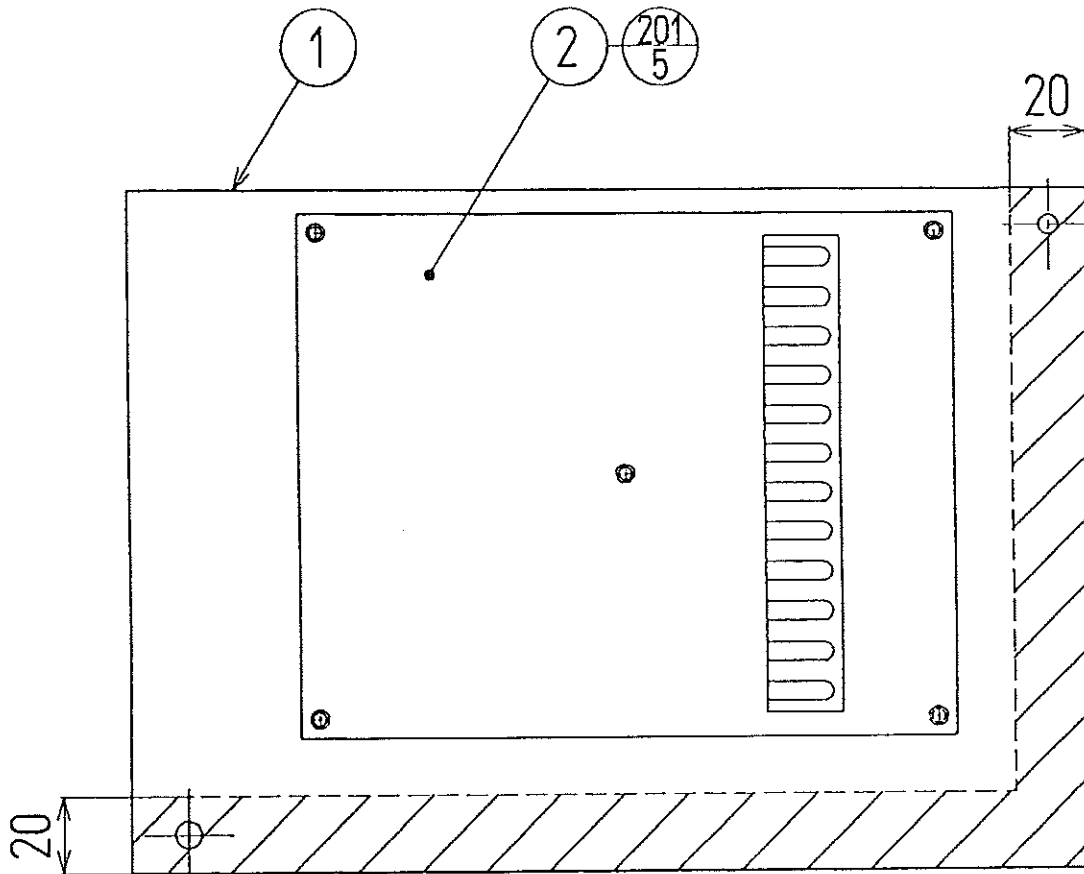

ITEM NO.	PART NO.	DESCRIPTION	NOTE
1	CPT-1401	WOODEN BASE AMP	
2	838-10018	AMP BD SERVO	
201	011-P00325	TAP SCR PH 3×25	



⑭ ASSY BUFFER BD (CPT-1410)

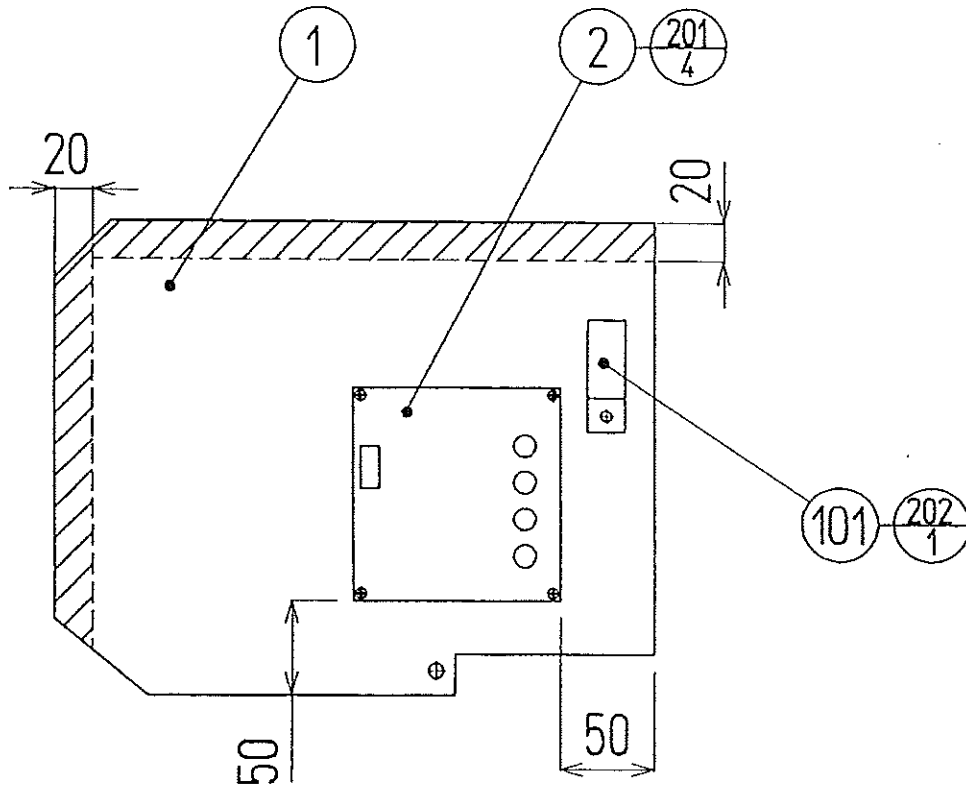

ITEM NO.	PART NO.	DESCRIPTION	NOTE
1	CPT-1411	WOODEN BASE VF	
2	839-0582	VPM BUFFER BD	
101	270-5009	LINE FILTER	
102	280-0419	HARNES LUG	
201	011-P00325	TAP SCR PH 3×25	
202	011-T03512	TAP SCR TH 3.5×12	
301	600-6656-13	WIRE HARN RGB BUFFER IN	

⑮ ASSY I/O BD (CPT-1420)

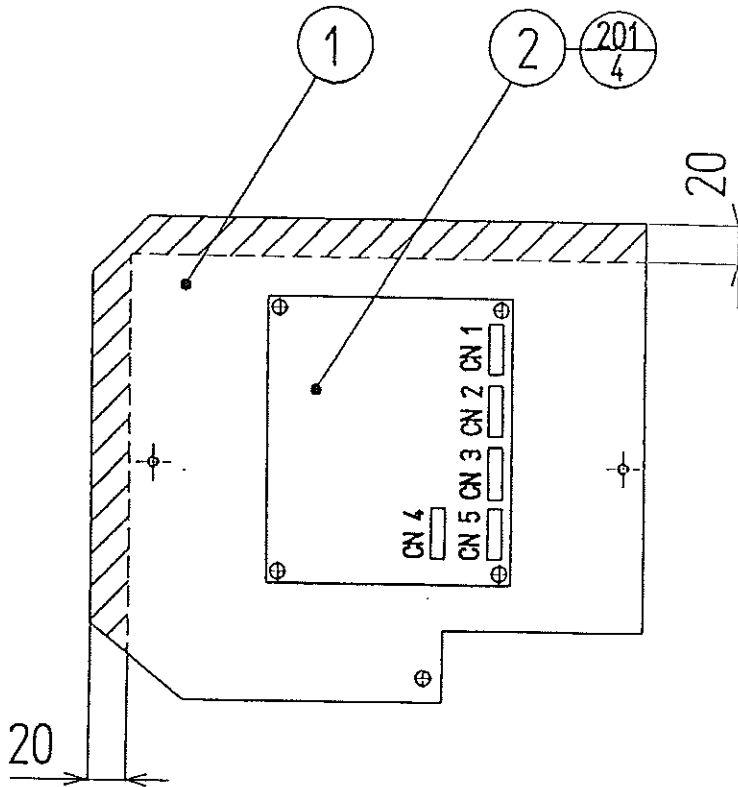

ITEM NO.	PART NO.	DESCRIPTION	NOTE
1	CPT-1421	WOODEN BASE I/O	
2	837-12079	IC BD GUN SENS A-CRX/B-CRX	
201	011-P00325	TAP SCR FH 3×25	

①⑥ ASSY SW REGU (CPT-1430)

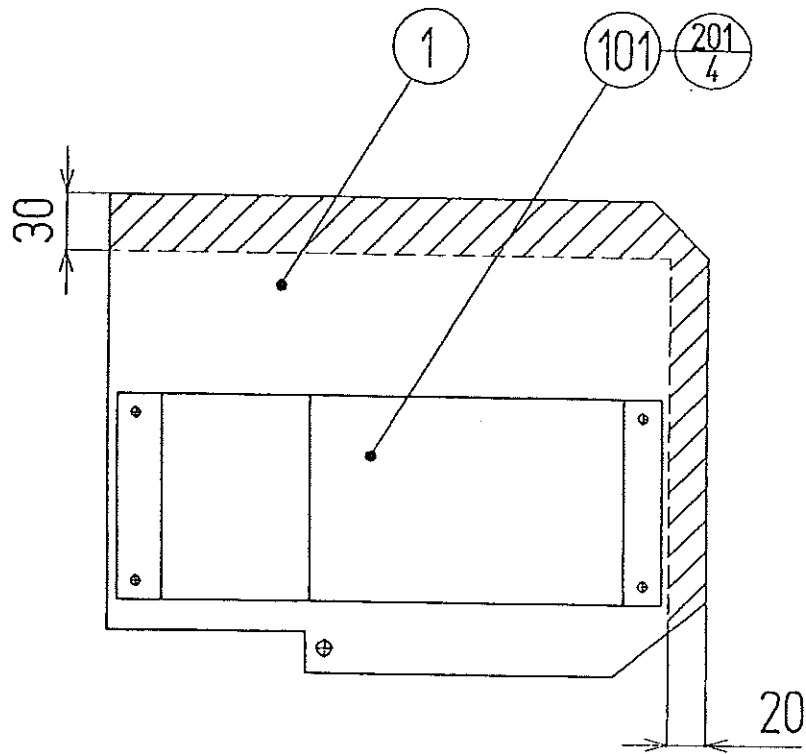

ITEM NO.	PART NO.	DESCRIPTION	NOTE
1	CPT-1431	WOODEN BASE SW	
101	400-5264	SW REGU +5V12A, +12V1.5A, -5V1A	
201	000-P00412-W	M SCR PH W/FS M4×12	

⑰ ASSY AC SPLY (CPT-1440)

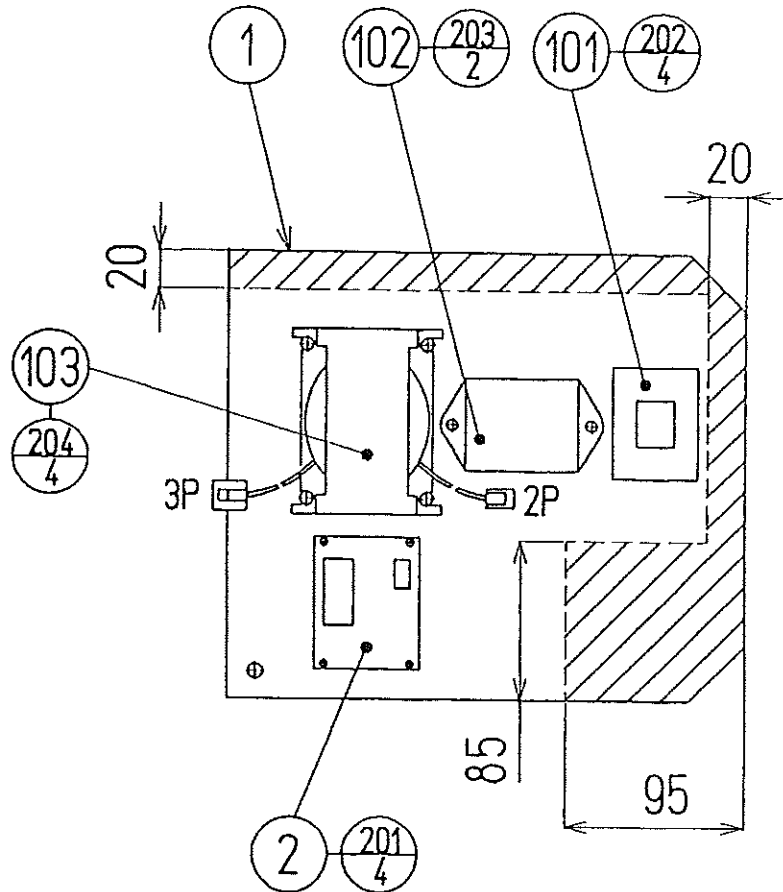

ITEM NO.	PART NO.	DESCRIPTION	NOTE
1	CPT-1441	WOODEN BASE AC SPLY	
2	838-10801-02	CONN BD B	
101	450-5090	MAGNET CONTACT SC-03 AC110V 1A	AC110V AREA
	450-5091	MAGNET CONTACT SC-03 AC240V 1A	AC240V AREA
	450-5092	MAGNET CONTACT SC-03 AC220V 1A	AC220V AREA
102	270-5022-01	NOISE FILTER 20A	
103	560-5250	XFMR AC100V 12.8V 6A	
104	280-0419	HARNES LUG	
105	601-0460	PLASTIC TIE BELT 100MM	
201	011-P00320	TAP SCR PH 3×20	
202	011-T03516	TAP SCR TH 3.5×16	
203	011-T00312	TAP SCR TH 3×12	
204	000-P00412-W	M SCR PH W/FS M4×12	
301	600-6656-03	WIRE HARN AC SPLY	
302	600-6656-04	WIRE HARN MAG. FLT	
303	600-6656-05	WIRE HARN FLT. CONN	

⑱ ASSY WIRE DX (CPT-1450)

ASSY WIRE DX (CPT-1450) is comprised of the following wire harnesses.  
An ASSY DRG. is unavailable.

ITEM NO.	PART NO.	DESCRIPTION	NOTE
101	601-0460	PLASTIC TIE BELT 100MM	
301	600-6656-08	WIRE HARN EARTH CONT PNL	
302	600-6656-09	WIRE HARN AC AMP	
303	600-6656-10	WIRE HARN DC OUT 1	
304	600-6656-11	WIRE HARN DC OUT 2	
305	600-6656-12	WIRE HARN RGB SENS IN	
306	600-6656-14	WIRE HARN SENS COMM	
307	600-6656-15	WIRE HARN AMP AUDIO	
308	600-6656-16	WIRE HARN EXT COIN&METER	
309	600-6656-17	WIRE HARN EXT START SW	
310	600-6656-18	WIRE HARN EXT SW UNIT	
311	600-6656-19	WIRE HARN EXT GUN	
312	600-6656-27	WIRE HARN EXT SPEAKER	

①⑨ METER UNIT (COP-1590)

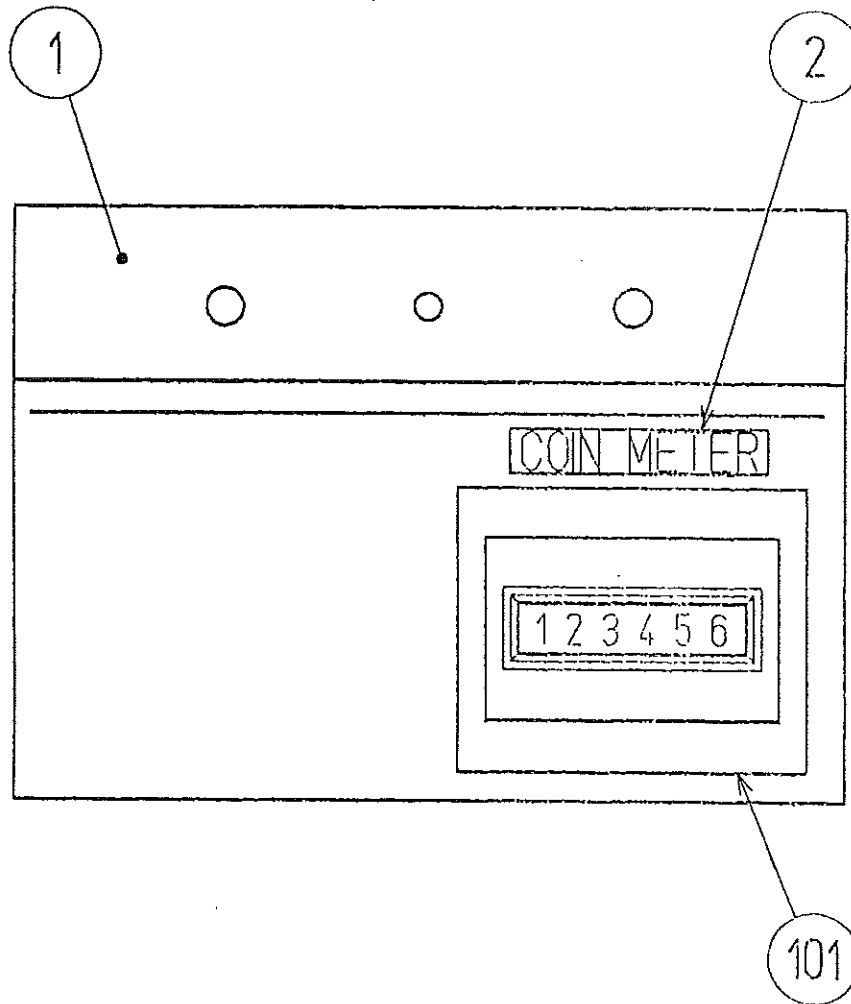

ITEM NO.	PART NO.	DESCRIPTION	NOTE
1	105-5108X	METER BRACKET	
2	421-6591-01	STICKER COIN METER	
101	220-5412 220-5217-01	MAG CNTR W/CONN MAG CNTR 6DIG DC 12V	OTHERS FOR MARS

②① ASSY CONT PANEL DX (CPT-2000)

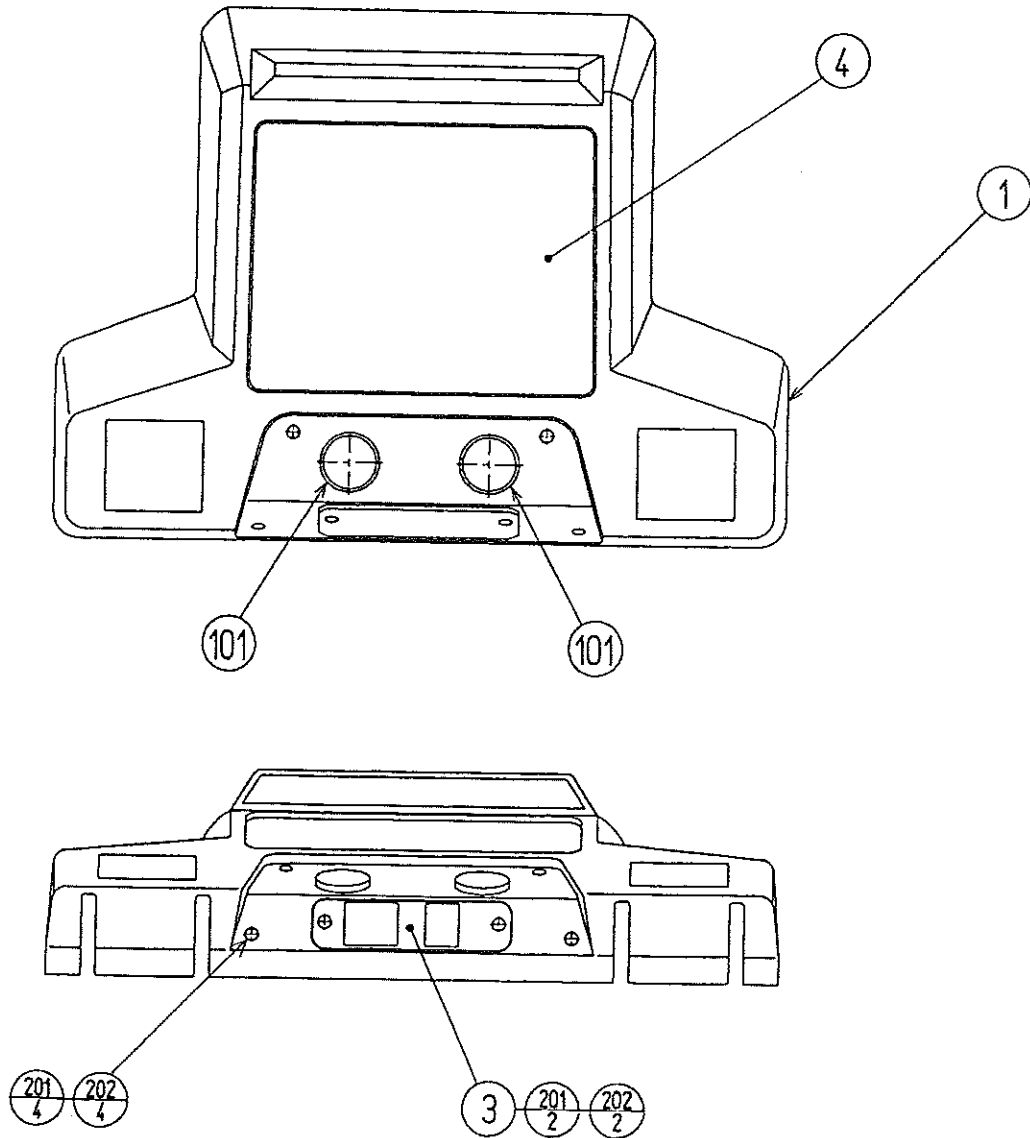

ITEM NO.	PART NO.	DESCRIPTION	NOTE
1	CPT-2001	CONT PNL	
3	CPT-2003	DENOMI PLATE	
4	CPT-2004-01	INST PLATE ENG	
101	509-5712-01	SW PB W/L 6V YELLOW	
201	031-000414-0C	CRG BLT CRM M4×14	
202	050-F00400	FLG NUT M4	
301	600-6656-20	WIRE HARN START SW & LAMP	

21 CONTROL UNIT 1P (COP-2000)

(D-1/2)

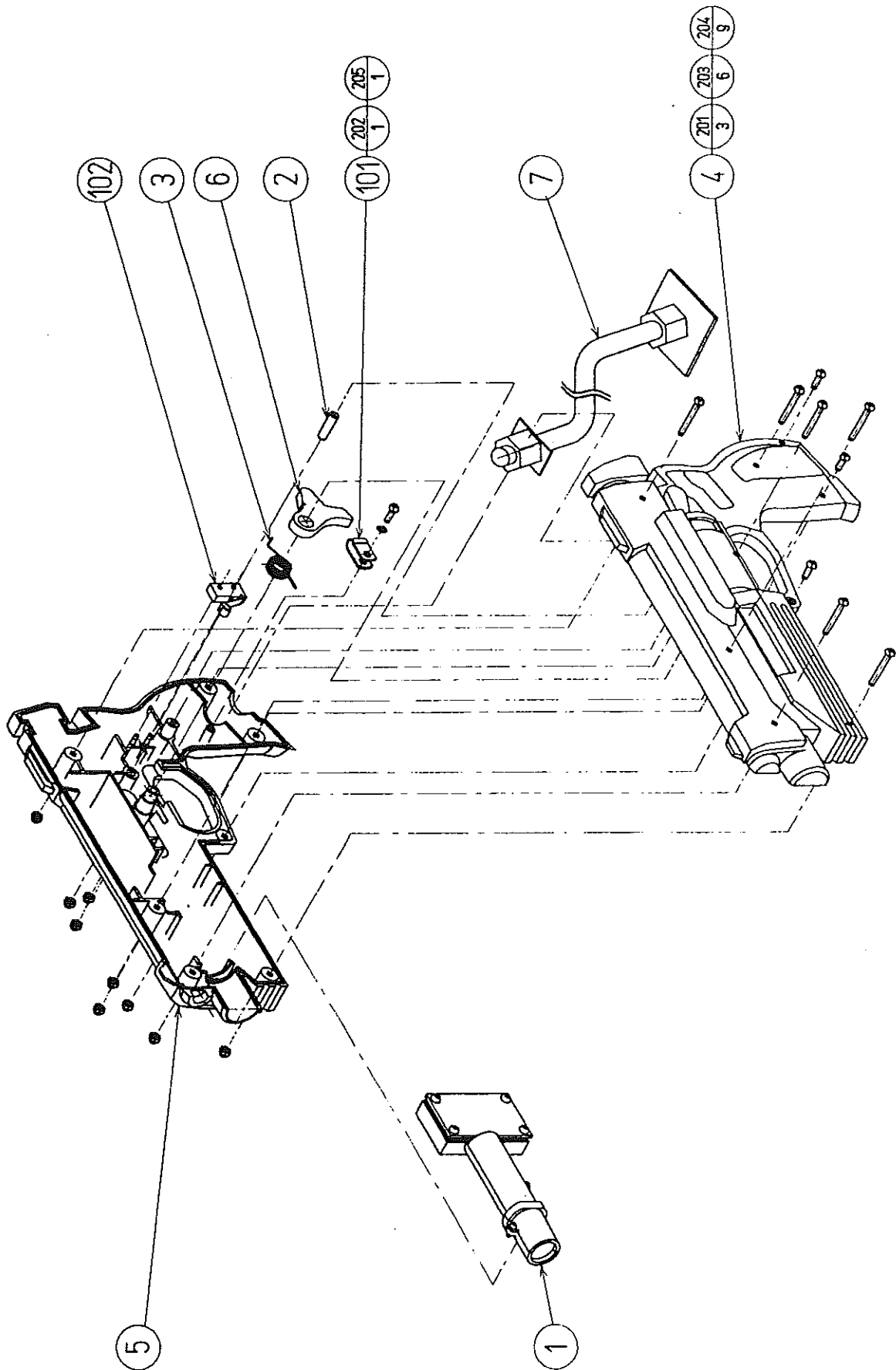



② CONTROL UNIT 1P (COP-2000)

(D-2/2)

ITEM NO.	PART NO.	DESCRIPTION	NOTE
1	COP-2020	SENSOR UNIT	
2	COP-2005	STOPPER PIN	
3	125-5124	TORSION SPRING	
4	253-5404-01	COVER LBFT BLUE	
5	253-5405-01	COVER RIGHT BLUE	
6	253-5406-01	TRIGGER BLUE	
7	601-7974	PROTECT TUBE NEW	
8	421-7226-02-91	STICKER B LONG	
101	280-5124-03	NYLON CLAMP NK03	
102	509-5080	SW MICRO TYPE	
103	601-0460	PLASTIC TIE BELT 100MM	
201	000-P00308-0B	M SCR PH BLK M3×8	
202	012-P00306	TAP SCR PH 3×6	
203	FAS-000015	M SCR PH BLK M3×25	
204	FAS-500006	CAP NUT TYPE 3 BLK M3	
205	060-F00300	FLT WSHR M3	
301	600-6456-30	WIRE HARN CONTROL UNIT	

②② SENSOR UNIT (COP-2020)

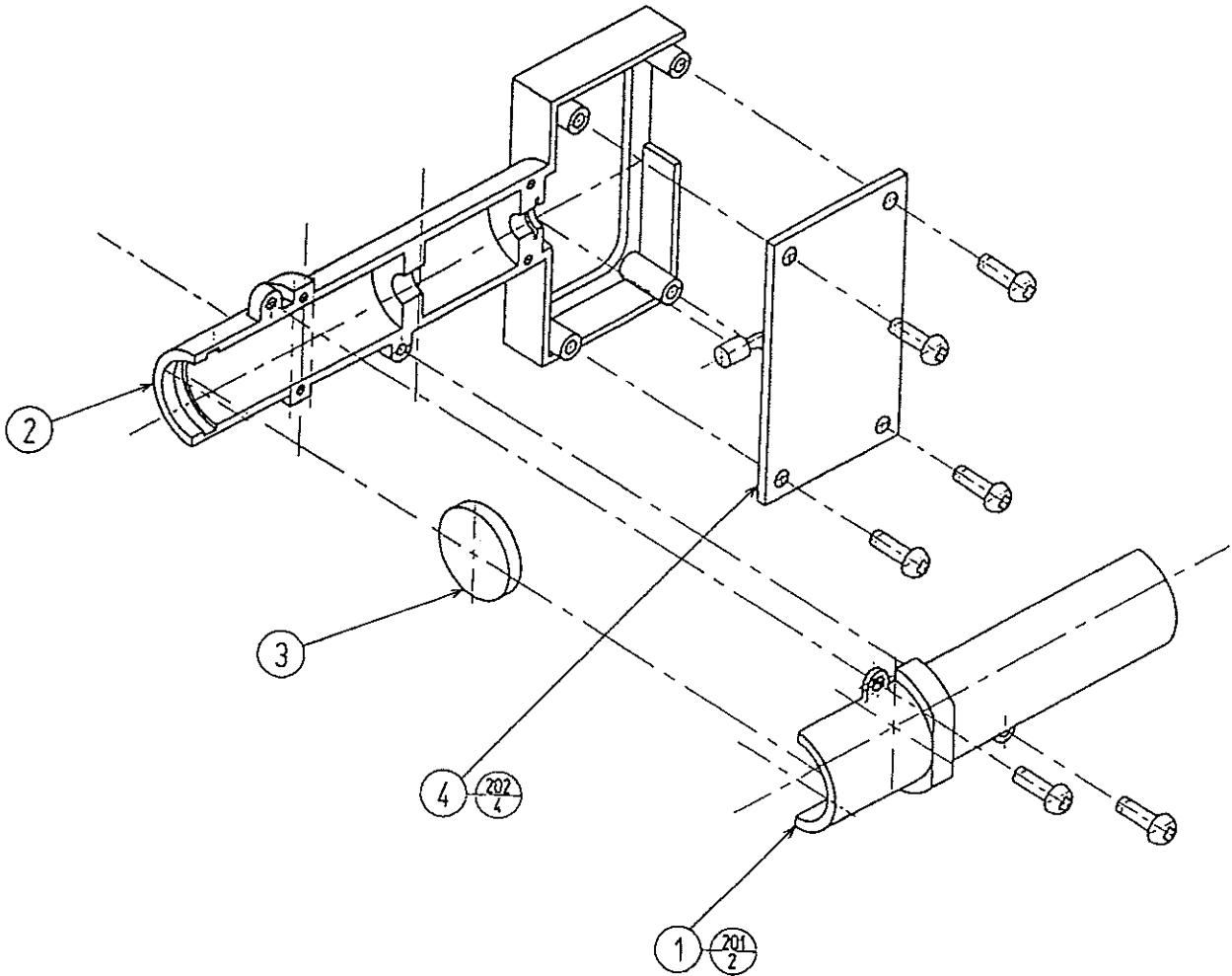

ITEM NO.	PART NO.	DESCRIPTION	NOTE
1	COP-2003	LENS HOLDER L	
2	COP-2004	LENS HOLDER R	
3	380-5003	LENS LP	
4	838-11145	SENSOR BD	
201	012-P02606	TAP SCR PH 2.6×6	
202	012-P00306	TAP SCR PH 3×6	



②③ CONTROL UNIT 2P (COP-2050)

(D-2/2)

ITEM NO.	PART NO.	DESCRIPTION	NOTE
1	COP-2020	SENSOR UNIT	
2	COP-2005	STOPPER PIN	
3	125-5124	TORSION SPRING	
4	253-5404-02	COVER LBFT RED	
5	253-5405-02	COVER RIGHT RED	
6	253-5406-02	TRIGGER RED	
7	601-7974	PROTECT TUBE NEW	
8	421-7226-18-19	STICKER R LONG	
101	280-5124-03	NYLON CLAMP NK03	
102	509-5080	SW MICRO TYPE	
103	601-0460	PLASTIC TIE BELT	
201	000-P00308-0B	M SCR PH BLK M3×8	
202	012-P00306	TAP SCR PH 3×6	
203	FAS-000015	M SCR PH BLK M3×25	
204	FAS-500006	CAP NUT TYPE 3 BLK M3	
301	600-6456-30	WIRE HARN CONTROL UNIT	



# 18. WIRE COLOR CODE TABLE

THE WIRE COLOR CODE is as follow:

- A PINK
- B SKY BLUE
- C BROWN
- D PURPLE
- E LIGHT GREEN

Wires other than those of any of the above 5 single colors will be displayed by 2 alphanumeric characters.

- 1 RED
- 2 BLUE
- 3 YELLOW
- 4 GREEN
- 5 WHITE
- 7 ORANGE
- 8 BLACK
- 9 GRAY

If the right-hand side numeral of the code is 0, then the wire will be of a single color shown by the left-hand side numeral (see the above).

Note 1: If the right-hand side alphanumeric is not 0, that particular wire has a spiral color code. The left-hand side character shows the base color and the right-hand side one, the spiral color.

<Example> 51 ..... WHITE / RED

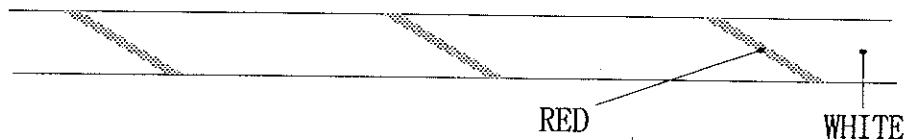

Note 2: The character following the wire color code indicates the size of the wire.

- K: AWG18, UL1015
- L: AWG20, UL1007
- None: AWG22, UL1007