



OPERATOR'S MANUAL



WAVE SHARK

© 1996 KONAMI ALL RIGHTS RESERVED.

WARNING

WAVE SHARK™ IS AN ORIGINAL GAME DEVELOPED BY KONAMI CO.,LTD. KONAMI CO., LTD.RESERVES ALL THE COPYRIGHTS, TRADEMARKS AND OTHER INDUSTRIAL PROPERTY RIGHTS WITH RESPECT TO THIS GAME.

Contents

■ About this product	1
■ Precautions for use	2
1 Specifications	7
2 Names of parts and list of main parts	8
3 How to play	10
4 Opening and closing the doors	
4-1 Opening and closing the maintenance door	11
4-2 Opening and closing the coin door	12
5 Networking game machines and PCB settings	
5-1 How to network game machines	13
5-2 Initializing the PCB	14
5-3 PCB start—up check (self test)	14
5-4 Adjusting the game position (manual test)	15
5-5 Mode descriptions	16
5-6 Measures to be taken when “DRIVING SYSTEM ERROR” is displayed	23
5-7 Measures to be taken when there is a network abnormality	24
6 Setting up the game machine	
6-1 Connecting the units	26
6-2 Fastening the adjusters	28
6-3 AC bracket	28
6-4 Service panel	29
6-5 Separating and moving the units	30
7 Maintenance and annex	
7-1 Replacing the coin selector	31
7-2 Replacing the fluorescent light	32
7-3 Replacing the start/view switch (lamp)	33
7-4 Replacing and adjusting the volume knobs	33
7-5 Replacing the belt and adjusting the belt tension	35
7-6 Adjusting the projector	37
7-7 Error code list	42
7-8 Wiring diagram	44

■ About this product

Thank you for purchasing this Konami product. This manual explains how to operate your game machine correctly and safely.



Failure to operate the machine correctly could result in malfunction or accidents, so please read the manual carefully before commencing operation. Be sure to operate the machine as described in this manual.

- The specifications of this product are subject to change without notice for reasons such as improving the performance.
- The contents of this game, its main data and design are protected by copyright law industrial property law.
- Unauthorized reproduction of this document or any of its contents is strictly forbidden.

© 1996 KONAMI ALL RIGHTS RESERVED.

■ Precautions for use

In this manual, the precautions to be followed without fail in order to prevent damage to persons to install, use or maintain “WAVE SHARK™” or other persons or to properties are shown as follows.

Be sure to read the following

- The following suggestions show the degree of danger and damage caused when the product is used improperly with the suggestions disregarded.



WARNING

indicates a situation where disregarding the suggestions could result in death or serious injury.



CAUTION

indicates a situation where disregarding the suggestions could result in injury or product damage.

- The following graphic suggestions describe the types of precautions to be followed.



indicates a matter of which care should be taken.



indicates a matter which is forbidden.











indicates a matter which should be performed without fail.

Setting Up



WARNING



- **Be sure to consult your nearest dealer when setting up, moving or transporting this product.**
 - ▶ This product should not be set up, moved or transported by anyone other than industry specialists. Doing so could result in injury or product damage.
 - ▶ When setting up this product, fasten the game machine securely with all the level adjusters. If the game machine is not fastened securely, injury or accidents could be caused by the machine rocking.
 - ▶ When setting up this product, take care that no undue force is applied to the connecting sections of the game machine. Failure to do so could cause injury, accidents or product damage.
- **This product is an indoor game machine. Never set up the game machine outside.** 
 - ▶ Setting up this product outside could result in accidents or equipment failure.
- **Do not set up the game machine near emergency exits.** 
 - ▶ Doing so could block exits in time of emergency and could result in death or serious injury.
- **Do not set up the game machine:** 
 - in a place exposed to rain or moisture
 - in a place exposed to direct sunlight
 - in a place exposed to direct heat from a heater, etc.
 - near hazardous flammable substances such as thinner and kerosene
 - on an inclined or uneven floor
 - near fire extinguishing equipment
 - in a place exposed to strong vibration
 - in a place exposed to excessive dust
 - near equipment generating strong magnetism or electric waves
- **Do not use the handrail at the both sides of the main unit to hoist the unit.** 
 - ▶ Doing so could cause an accident or damage.
- **Do not place containers holding chemicals or water on or near the game machine.** 
 - ▶ Electrical shock or damage could be caused by water or foreign matter entering the inside of the machine.
- **Do not place items near the ventilating holes.** 
 - ▶ Doing so could cause the internal temperature to rise excessively, resulting in equipment failure.
- **Do not bend the power cord by force or place heavy objects on it.** 
 - ▶ Doing so could result in electric leakage or fire.
- **Never plug or unplug the power cord with wet hands.** 
 - ▶ Doing so could result in electrical shock.
- **Never unplug by pulling on the power cord.**
 - ▶ Doing so could damage the cord, resulting in electric leakage or fire.
- **Use an earthing band or similar means of discharging static electricity when adjusting the PCB DIP switches.**
 - ▶ If not discharged, static electricity could damage the electronic components on the board.

Precautions for use

Setting



CAUTION





- Be sure to use indoor wiring for within the specified voltage range. For extension cord, use indoor wiring of the specified rating or more.
 - ▶ Failure to do so could result in fire or equipment failure.
- Never plug more than one cord at a time in the electrical receptacle.
 - ▶ Doing so could result in fire or electrical shock.
- Do not run the power cord across passages where pedestrians' feet could get caught on the cord. 
 - ▶ This could cause pedestrians to fall and injure themselves, or could damage the power cord. 
- Be sure to connect a earth cable to the ground terminal of the game machine.
- Clearances of 100mm(3.94in) or more should be created between the game machine and walls.



Operation



WARNING

- Anyone who falls under any of the following categories should not use this machine.
 - ▶ Doing so could cause an accident, induce illness or aggravate the current disease. 

<ul style="list-style-type: none">• Those who are under the influence of alcohol.• Those who are in poor physical condition.• Those who suffer from high blood pressure or heart disease.• Those who cannot walk without help.	<ul style="list-style-type: none">• Those who have spinal cord disease.• Those who have a pacemaker inserted.• Those who tend to get motion sickness.• Those who are or may be pregnant.
---	---
- Do not permit more than one rider on the machine. A rider should be restrained only in the blue-mat area during playing. Do not get on the machine with poor-balanced shoes;
 - ▶ otherwise, it will cause personal injury or an accident. 
- Do not remove hands away from the handle and use caution to prevent fingers from getting pinched in the wheel during playing;
 - ▶ otherwise, it will cause personal injury or an accident. 
- Give a warning to others to stay away from the machine during operation.
 - ▶ Failure to do so will result in personal injury or an accident.
- Do not use this product anywhere other than industrial areas.
 - ▶ Using in a residential area or an area next to a residential area could affect signal reception of radios, television sets, telephones, etc. 
- If there is any abnormality such as smoke, bad smell or abnormal noise being emitted from the machine, immediately unplug the power cord to stop operating it. 
 - ▶ Using the machine in abnormal conditions could result in fire or accidents.

<ol style="list-style-type: none">1. Turn off the power.2. Unplug the power cord.3. Contact your nearest dealer.	In case of abnormality:
--	-------------------------
- Do not leave the power cord plugged improperly or covered with dust.
 - ▶ Doing so could result in electrical shock or fire, so inspect the power cord periodically. 
- Never disassemble, repair or modify any section other than those specified in this manual.
 - ▶ Doing so could result in fire, malfunction or equipment failure. 

Operation



CAUTION

- Do not plug or unplug the power cord with wet hands.

▶ Doing so could result in electrical shock.



- When handling the power cord, take care of the following:

▶ Improper handling could result in fire or electrical shock.



- | | |
|---|--|
| • Do not damage the power cord. | • Do not modify the power cord. |
| • Do not bend the power cord excessively. | • Do not twist the power cord. |
| • Do not heat the power cord. | • Do not pull the power cord. |
| • Do not bind the power cord. | • Do not tread on the power cord. |
| • Do not sandwich the power cord. | • Do not drive a nail into the power cord. |

- If the power cord or power plug becomes damaged, immediately stop using the machine.

▶ Using a damaged power cord or power plug could result in fire or electrical shock.

Inspection and cleaning



WARNING

- Be sure to turn off the power and unplug the power cord from the receptacle before inspecting or cleaning the machine.

▶ Failure to do so could result in electrical shock.



- Do not turn the power off while you are playing the game. Make sure the machine is in the demonstration mode before turning the power off;

▶ otherwise the main body will not be properly locked so that the seat could jolt, resulting in an accident.



- When replacing parts, be sure to use parts of the correct specifications. Never use parts other than the specified ones.

▶ Using improper parts could result in fire or equipment failure.



- Never disassemble, repair or modify any section other than those specified in this manual.

▶ Doing so could result in fire, malfunction or equipment failure.



- To clean the game machine, wipe it with a soft cloth dampened in a neutral detergent and wrung out.



▶ Using organic solvents such as thinner may decompose the material.

▶ Electrical shock or equipment failure could be caused by water entering the inside of the machine.

Moving and Transportation





CAUTION

- The game machine contains parts such as a projector, electronic components and precision components which are sensitive to vibration and impact. Great care therefore should be taken when moving and transporting the game machine. Be sure not to let the machine tip over. 
- Fully raise all the adjusters before moving the game machine and move it utilizing the casters. Be sure to turn off the power and unplug the power cord from the receptacle before moving the game machine. 
 - ▶ Failure to do so could result in accidents, damage or equipment failure.
- Take care that no undue force is applied to the connecting sections of the game machine when moving it.
 - ▶ Failure to do so could cause injury, accidents or product damage.

Disposal



WARNING

- When disposing of the projector of this product, do not leave it with the screen exposed. 
 - ▶ Doing so could result in fire due to direct sunlight, etc.
- If the screen is removed, be careful not to leave it in direct sunlight. 
 - ▶ Doing so could cause burns or fire.

PRECAUTION IN
HANDLING

- When setting up, handling, inspecting, maintaining, moving or transporting this product, follow the procedures and instructions set forth in this manual and perform such work safely.
- Do not remove labels of "WARNING", "CAUTION", etc. attached to the product.
- Do not set up, handle, inspect, maintain, move or transport this product under conditions equivalent to the condition of "WARNING" or "CAUTION" specified in this manual.
- If a new owner is to have this product as a result of transfer, etc., be sure to give this manual to the new owner.

1 Specifications

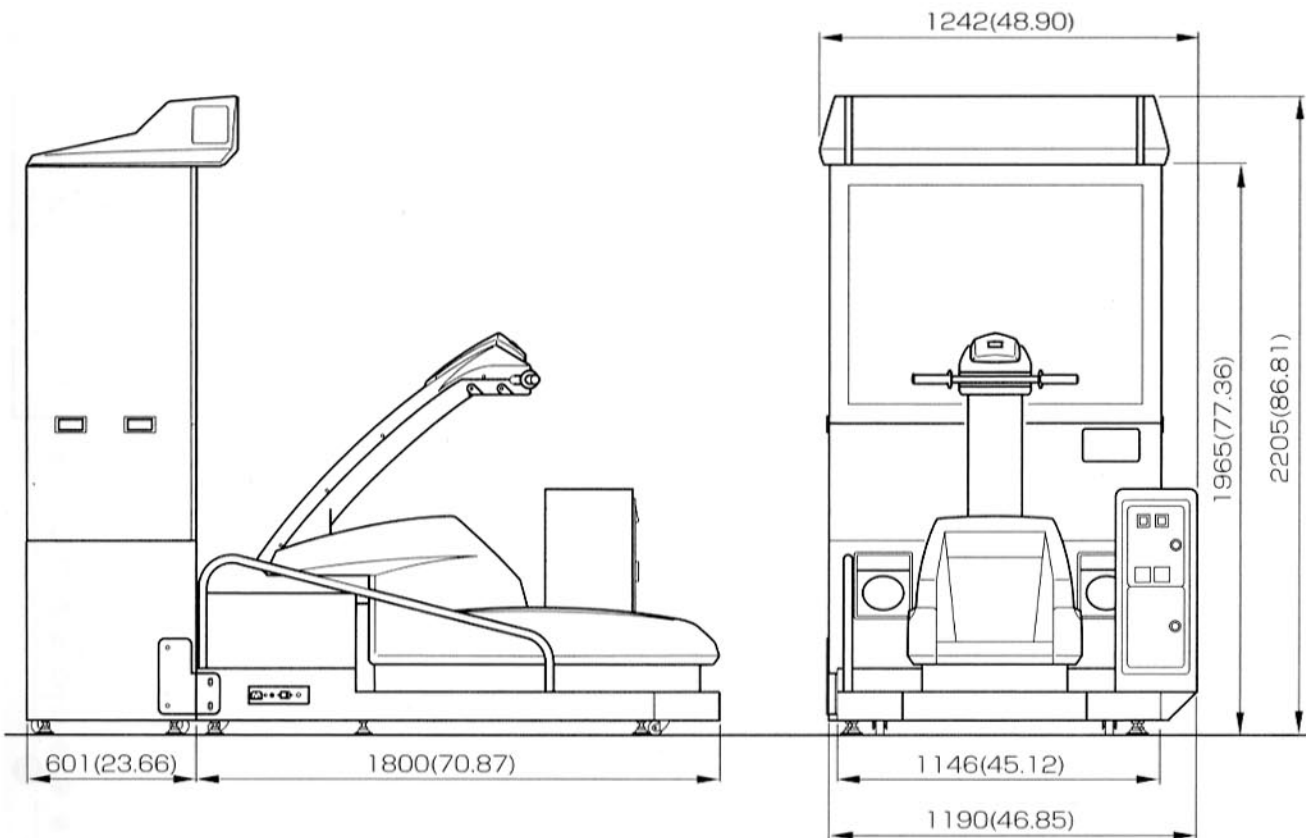

Specifications

Dimensions	Refer to the figure above: mm (in)
Weight	Projector unit: Approx. 140 kg (309lb) Main unit : Approx.268kg (591lb) Billboard : Approx.17kg (37lb)
Power consumption	Max. 280 W
Monitor	50-inch color projector
Service condition	Temperature 10 to 35°C (50to95°F) Humidity 20 to 80% (No dewing is allowed.)
Attachments	<ul style="list-style-type: none"> • Instruction manualthis manual • Keys for cash box2 • Keys for maintenance2 • Networking cord1 • Remote control for adjusting projector1 • UM-4(AAA batteries)2 • Seal for remote control for adjusting projector1

● If any part is defective or not found, contact your nearest dealer.
 The specifications of this product are subject to change without notice for reasons such as improving the performance.

2 Names of parts and list of main parts

■ Main machine

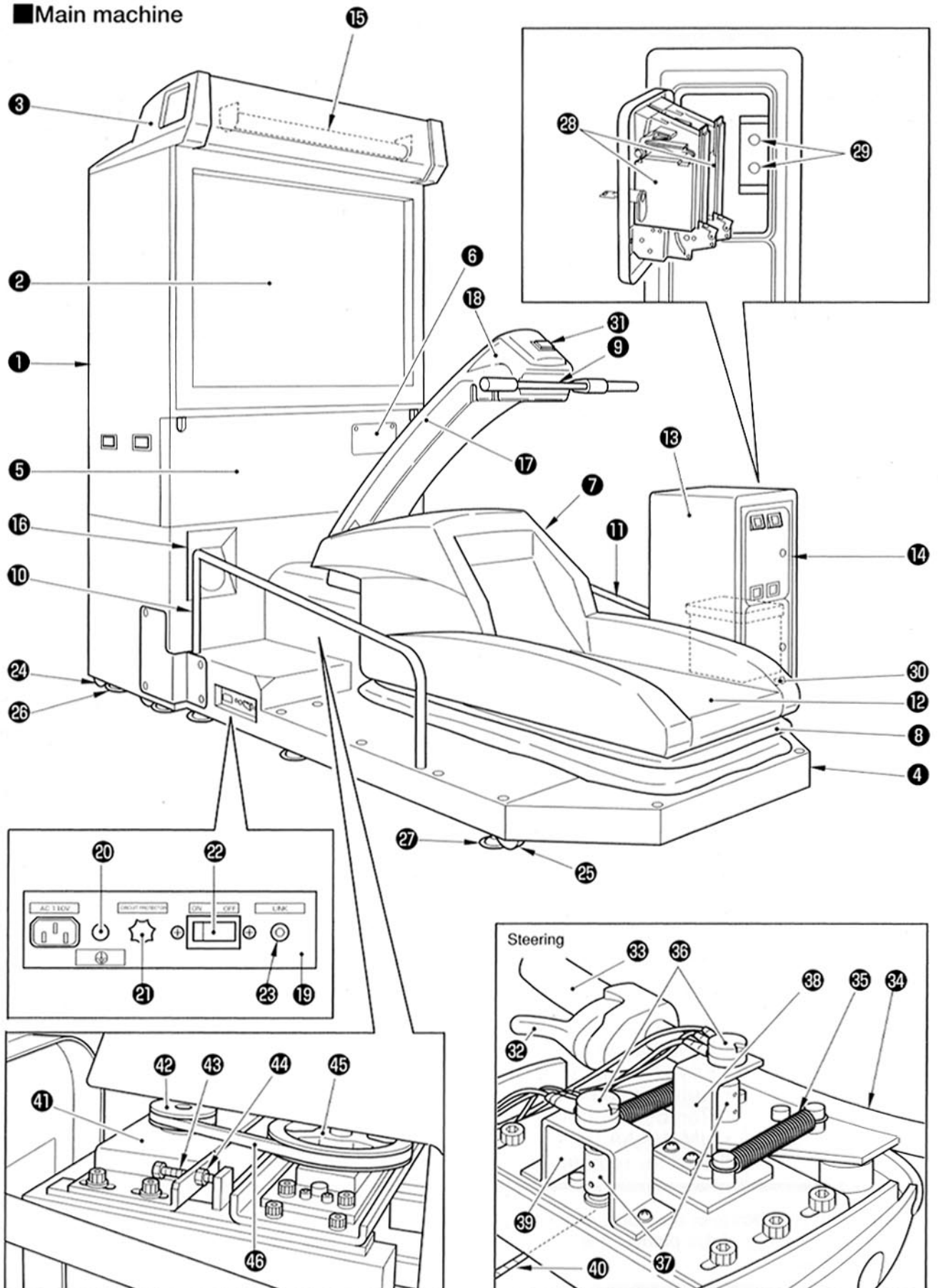

2 Names of parts and list of main parts

No.	Part name	Part#	Quantity	Remarks
①	Projector unit	—	1	
②	Projector	002243	1	
③	Billboard	—	1	
④	Main unit	—	1	
⑤	Projector maintenance door (large)	100494	1	
⑥	Projector maintenance door (small)	402688	1	
⑦	Main body (hull)	100466	1	
⑧	Bellows	302142	1	
⑨	Steering unit	—	1	
⑩	Handrail bar (left)	302172A	1	
⑪	Handrail bar (right)	302173A	1	
⑫	Mat	302143	1	
⑬	Operator's box	100504	1	
⑭	Door unit	002484	1	
⑮	Fluorescent light unit	002239	1	
⑯	Speaker	002351	2	
⑰	Beam	—	1	
⑱	Beam cover	200526	1	
⑲	AC bracket	302150	1	
⑳	Ground terminal	055905	1	
㉑	Circuit protector	002483	1	
㉒	Main power switch	055233	1	
㉓	Network terminal	501015	2	
㉔	Caster	000751	4	Projector unit
㉕	Caster	002355	4	Main unit
㉖	Adjuster	002102	4	Projector unit
㉗	Adjuster	001027	6	Main unit
㉘	Coin selector	—	2	
㉙	Service & test switch	054337	2	
㉚	Coin meter	054339	1	
㉛	Start/view switch	002383	1	
㉜	Accelerator lever	002352	1	
㉝	Grip	002354	2	
㉞	Handle bar	200532	1	
㉟	Spring	002376	2	
㊱	Volume knob	001123	2	
㊲	Coupling	002357	2	
㊳	Volume knob bracket	402708A	1	For Steering bar
㊴	Volume knob bracket	402723	1	For accelerator lever
㊵	Wire	402701A	1	
㊶	Motor bracket	302192	1	
㊷	Pulley (small)	402710	1	Motor side
㊸	Adjuster bolt	—	2	
㊹	Lock nut	—	2	
㊺	Pulley (large)	302188A	1	Ball screw side
㊻	Belt	002556	1	

3 How to play

This game machine is designed to enjoy marine sports.

The machine can bank to the right and left sides and hop as well. Moreover, Realistic pictures made by using polygons produce realistic feeling of flying over the water surface and create unique operating feel. Enjoy the water race and run your machine toward the goal.

■ How to play

1. Drop a coin to start the game.
※ In the free play mode, press the [START/VIEW] switch to start the game.
2. The Network Entry screen appears. If a coin(s) is dropped into another machine which connected to this machine through the network with this screen displayed, a network race begins automatically.
If the machine is not connected to the network, the game begins at the item 3 after a coin(s) is dropped.
3. Select anyone out of the four riders on the player selecting screen by using the handle and press the [START/VIEW] switch to set. There are two different player modes "Beginner" and "Advanced". In the "Beginner" player mode, the participant who plays the game for the first time can enjoy playing and in the "Advanced" player mode, difficult acceleration and cornering technique are required.
4. Select a course on the course selecting screen by using the handle and press the [START/VIEW] switch to set. There are three different courses: "Beginner", "Intermediate" and "Advanced". Their features are as follows:
 - NOVICE (Beginner) West Coast (West Coast course)
 - EXPERT (Intermediate) Island Course (Resort course)
 - PRO (Advanced) Lagoon Course (European canal course)After the course is selected, the game starts. The race begins when the countdown starts on the screen.
5. The basic operation is as follows:
 - Cornering Turning the handle clockwise or counterclockwise turns the machine. Quick cornering can be achieved by shifting your weight to bank the machine to the right or left side.
 - Acceleration The right lever of the handle is the accelerator. The machine speed increases by squeezing the lever and decreases by releasing it.
 - Big Jump Raising the handle at the same time as the machine rides on a wave or on a jumping stand jumps the machine.
6. Every time you pass one of the checkpoints located along the course, extra play time is added to your remaining time.
7. The game ends when you have completed the required numbers of laps, or when the play time reaches 0.
8. The game results, i.e., the course, remaining time, position, course record and each lap time are displayed on the screen.

■ Buy-in during the game

In WAVE SHARK, no buy-in is allowed while the game is in Progress.

4 Opening and closing the doors

4-1 Opening and closing the maintenance door

■ How to open the maintenance door



- Take care not to apply any load or impact to the maintenance door when it is open.

- 1 | Insert the attached maintenance key and turn it clockwise.

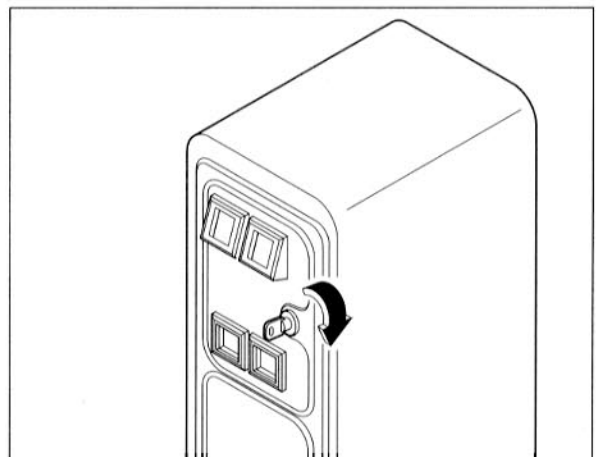

- 2 | Open the maintenance door.

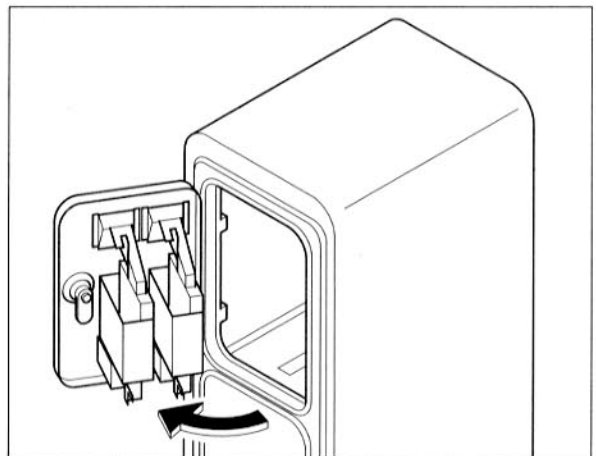

■ How to close the maintenance door

- 1 | Close the maintenance door.
- 2 | Turn the maintenance key counter clockwise.

4-2 Opening and closing the coin door

■ How to take out the cash box



- Securely lock the door for protection against theft.
- Note that the cash box is considerably heavy to take out if it is full of coins.
- Make sure that the main body is locked before trying to pull the cash box.

- 1 Insert the attached coin key into the keyhole of the door in the lower portion of the operator's box, and turn it clockwise.
- 2 Open the coin door and take out the cash box.

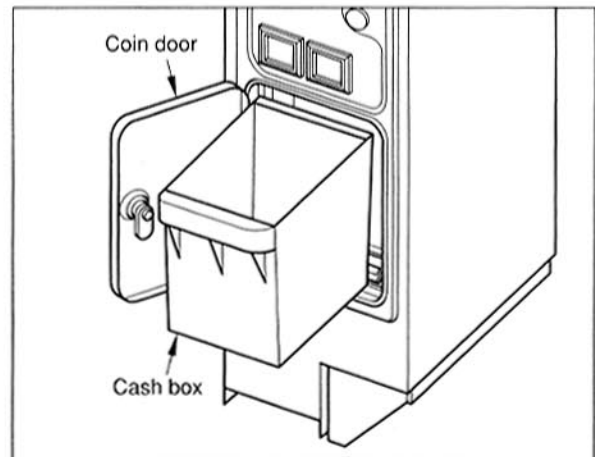

■ Coin meter

You will find the cash box when the coin door is opened.
The coin meter is located under the cash box.

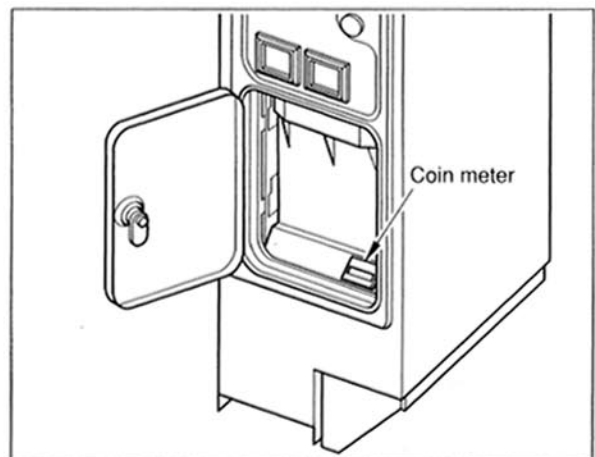

5 Networking game machines and PCB settings

5-1 How to network game machines

The specification of the main game machine PCB allow up to four game machines to be connected so that players can enjoy versus games. To network, connect the networking cord supplied with each game machine to the network pin jack of the main unit after setting up the game machines.



- When using the game machine independently, do not connect anything to the pin jack.
- Game machines are linked together in a chain with the networking cords. Do not connect anything to the first and last pin jacks in the chain.
- When networking game machines, set the PCB main board dip switch "Network ID" while referring to "DIP SWITCH SETTINGS" on page 20.

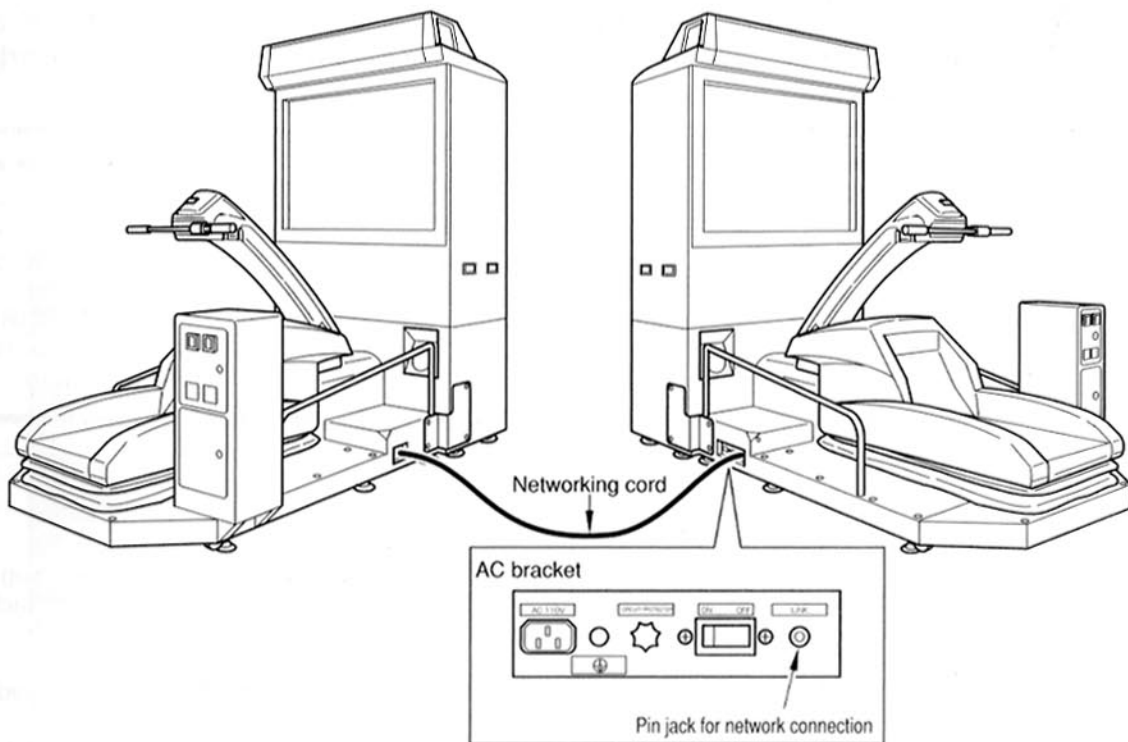

■ Networking four game

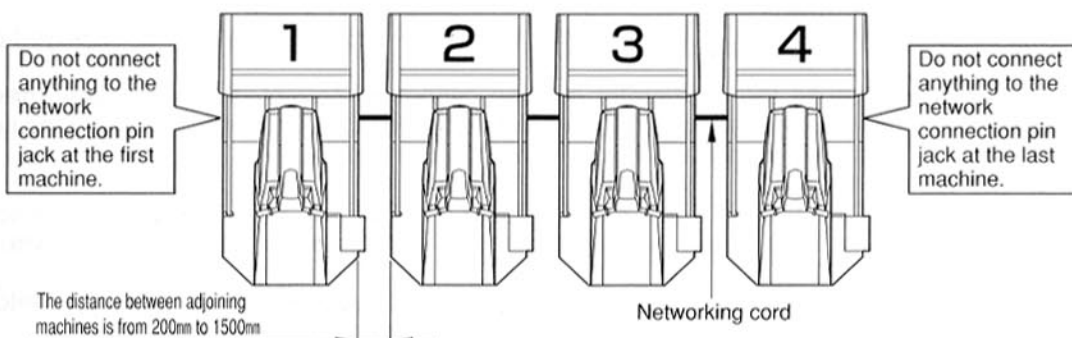

5-2 Initializing the PCB

■ Be sure to initialize the PCB according to the following procedures after installing the game machine, repairing or replacing the PCB to ensure proper functioning of the game.

- 1 While pressing the test switch on the service panel, turn on the main power. (This operation should be performed by two persons.) (This will return all the manual test settings to the original factory settings at the time of shipment.)
- 2 Initialization is completed when the "EEP-ROM INITIALIZE COMPLETE" message is displayed after the "EEP-ROM BIT CHECK OK" message being displayed. If the test switch is not released, the "TEST SWITCH IS STILL ON. PLEASE RELEASE IT OR REPAIR" message will appear.
When the test switch is released, this message will disappear. If this message appears in spite of the test switch not being pressed, contact your nearest dealer.

5-3 PCB start-up check (self test)

When the power switch is turned ON after the installation of the game machine, the self test is conducted automatically.



● Be sure to perform the self test before using the machine. If an abnormality persists or the machine does not operate properly, immediately turn OFF the power to stop operating the machine.

■ Result of test

If test is OK

- After the EEPROM check is completed, the start-up check of the machine and the correction of the steering bar and accelerator positions are performed automatically. At this time, the message "MACHINE INITIALIZE. PLEASE DO NOT RIDE THIS MACHINE DURING INITIALIZE." is displayed on the screen. Do not touch the steering bar, accelerator or brake while this message is displayed. If everything is normal, the game mode screen will appear.

If an abnormality is detected

The test results are displayed on the screen.

- **EEP-ROM abnormality**
The message "EEP-ROM BAD" is displayed on the screen.
What to do... Turn OFF the power switch, and then turn ON the power switch while pressing the test switch. (This will return all the manual test settings to the original factory settings at the time of shipment.)
- **Steering bar abnormality**
The message "PLEASE ADJUST THE STEERING BAR MECHANICALLY" is displayed on the screen.
What to do... Because the steering bar position cannot be corrected automatically, make the necessary adjustments mechanically while referring to "7-4 Replacing and adjusting the volume knobs" on pages 33 and 34.
- **Accelerator abnormality**
The message "PLEASE ADJUST THE ACCEL LEVER MECHANICALLY" is displayed on the screen.
What to do... Because the accelerator position cannot be corrected automatically, make the necessary adjustments mechanically while referring to "7-4 Replacing and adjusting the volume knobs" on pages 33 and 34.
- **Driving system error**
The message "DRIVING SYSTEM ERROR ERROR CODE ○○" is displayed on the screen.
What to do... When any of the error codes 1 to 16 is displayed, turn off the power switch immediately.
When any of the error codes 17 to 25 is displayed, turn off the power switch after waiting for more than 3 minutes and turn on the power switch again.

5-4 Adjusting the game position (manual test)

Manually check and change the settings for the screen displays and game contents.

Starting the manual test mode

- 1 Turn on the power switch.
- 2 Press the test switch on the service panel during the game mode demo (during the game mode demo of all the game machines in case of networking) . (Turning ON the power while holding down the test switch will return all the present manual test settings to the original factory settings at the time of shipment.) The unit is set in the manual test mode and the main menu is displayed on the screen.

Ending the manual test mode

- 1 Select [GAME MODE] on the main menu screen.
- 2 Press the [START/VIEW] switch.
 - The unit is set in the game mode.

Main mode screen (basic items)

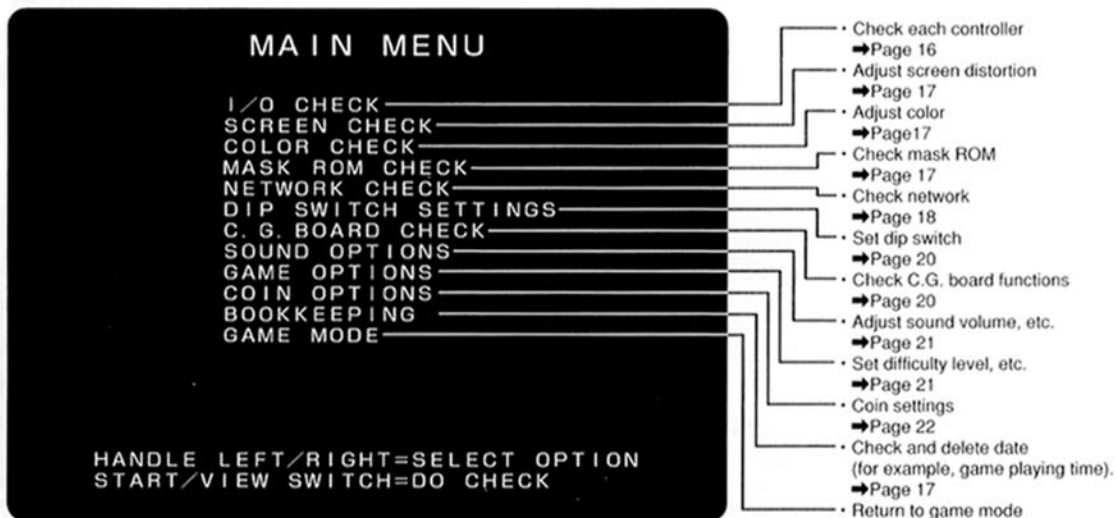

Selecting each mode

How to select each mode from the main menu

- Select → Move the steering bar up or down.
- Set → Press the [START/VIEW] switch

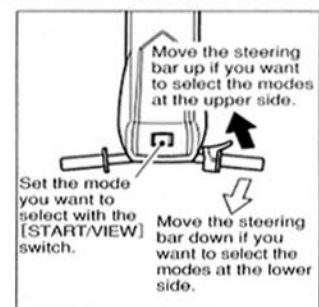

After selecting a mode, refer to the page on which the selected mode is described in details.

If the handle or the accelerator is not properly adjusted, make necessary adjustments, referring to “7-4 Replacing and adjusting the volume knobs” on pages 33 to 34.

If “ALM” indicates “ON”, turn off the power switch after waiting for more than 3 minutes and turn on the power switch again.

MEMO

SCREEN CHECK

- The check mode for the screen display.

Adjust the focus, distortion and size of the screen while looking at the grille screen. Use the projector adjustment PCB (see page 37) to make adjustments. To return to the main menu screen, press the [START/VIEW] switch.

COLOR CHECK

- The check mode for the color display.

Make adjustments using the projector adjustment PCB (see page 37) so that the color of the color bar is displayed at the optimum level. To return to the main menu screen, press the [START/VIEW] switch.

MASK ROM CHECK

- This checks each ROM in order, and displays “OK” or “BAD” at the end of the check. To return to the main menu screen, press the [START/VIEW] switch.

BOOKKEEPING

- The check mode for the game playing time of each course.

Use this mode when changing the difficulty level setting of the game. If the [TEST] switch and the [SERVICE] switch on the service panel are pressed at the same time, all recorded data (including score data) will be deleted.



- Take special care not to turn off the power switch during playing; otherwise the data in memory might be erased. If there is trouble with the data in memory, turn on the power switch with the [TEST] switch on the service panel pressed to initialize the PCB.

NETWORK CHECK

■ The network communication check mode.

Observe the screen in this mode for at least one minute to make sure that the following three items are responding as described below. To return to the main menu screen, press the [START/VIEW] switch.



● If any of the three items responds incorrectly, it indicates possible communication malfunction. Take measures while referring to “5-7 Inspection procedure when there is a network abnormality” on page 24. If the same symptom persists in spite of taking measures or a problem not covered in this manual occurs, immediately turn off the power switch to stop operating the machine.

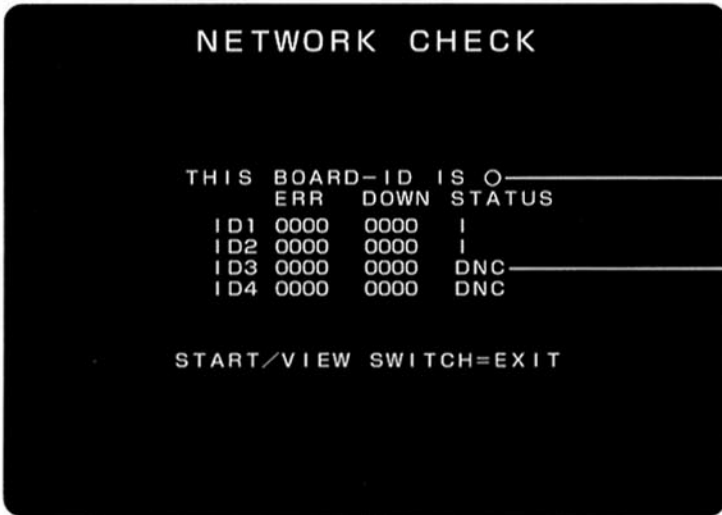

• Shows the “Network ID” of the connected game machine.
(A number for 1to4)

• “DNC” (did not connect) appears if connection is made.

- Check items
- Check that the “I” mark in the STATUS column is moving from the left to the right at a fixed speed.
 - Check that the value in the ERR column is below “10” after one minute.
 - Check that the value in the DOWN column does not change from “0000” .

■ Screen display when game machines are networked

● Two game machines are networked

Screen for player 1

```

NETWORK CHECK

THIS BOARD-ID IS1
ERR DOWN STATUS
ID1 0000 0000 |
ID2 0000 0000 |
ID3 0000 0000 DNC
ID4 0000 0000 DNC

START/VIEW SWITCH=EXIT
    
```

Screen for player 2

```

NETWORK CHECK

THIS BOARD-ID IS2
ERR DOWN STATUS
ID1 0000 0000 |
ID2 0000 0000 |
ID3 0000 0000 DNC
ID4 0000 0000 DNC

START/VIEW SWITCH=EXIT
    
```

● Four game machines are networked

Screen for player 1

```

NETWORK CHECK

THIS BOARD-ID IS1
ERR DOWN STATUS
ID1 0000 0000 |
ID2 0000 0000 |
ID3 0000 0000 |
ID4 0000 0000 |

START/VIEW SWITCH=EXIT
    
```

Screen for player 2

```

NETWORK CHECK

THIS BOARD-ID IS2
ERR DOWN STATUS
ID1 0000 0000 |
ID2 0000 0000 |
ID3 0000 0000 |
ID4 0000 0000 |

START/VIEW SWITCH=EXIT
    
```

Screen for player 3

```

NETWORK CHECK

THIS BOARD-ID IS3
ERR DOWN STATUS
ID1 0000 0000 |
ID2 0000 0000 |
ID3 0000 0000 |
ID4 0000 0000 |

START/VIEW SWITCH=EXIT
    
```

Screen for player 4

```

NETWORK CHECK

THIS BOARD-ID IS4
ERR DOWN STATUS
ID1 0000 0000 |
ID2 0000 0000 |
ID3 0000 0000 |
ID4 0000 0000 |

START/VIEW SWITCH=EXIT
    
```

DIP SWITCH SETTINGS

■ The DIP switch setting check mode. (Set DIP switch)
 When changing the DIP switch settings, refer to the chart below. To return to the main menu screen, press the [START/VIEW] switch.

!

● Be sure to turn OFF the power switch before setting the DIP switch.

■ DIP switch setting chart

● Main board (upper PCB) DIP switch

● Set the all DIP switches on the C.G. board (PCB shown below) for OFF.

Setting	1	2	3	4
C.G. board settings specifications (Always OFF)	OFF			
AT/MT (Always OFF)		OFF		
Network ID	First machine		OFF	OFF
	Second machine		ON	OFF
	Third machine		OFF	ON
	Fourth machine		ON	OFF

- When setting DIP switch of networking game machines, number each switch in the sequence of the small number. (Example: When networking two game machines, set the network ID of one machine to 1 and the other to 2.)
- The DIP switch on the PCB can be shifted easily by utilizing a thin flatblade screwdriver or a ball-point pen.

MEMO

C.G.BOARD CHECK

(check C.G. board functions)

■ The C.G. board function check mode.
 Observe the screen in this mode to check whether the C.G. board is functioning properly. To return to the main menu screen, press the [START/VIEW] switch.



- The logo is displayed in front of the cubes.
- The two cubes are rotating.
- The image behind the cubes rotates.

SOUND OPTIONS

(Adjust sound volume)

■ The following screen appears when this mode is selected.

SOUND OPTIONS

SOUND IN ATTRACT MODE ALL THE TIME
 SOUND SCALE CHECK
 SOUND VOLUME UP -----
 SOUND VOLUME DOWN -----
 FACTORY SETTINGS
 SAVE AND EXIT
 EXIT

HANDLE LEFT/RIGHT = SELECT OPTION
 START/VIEW SWITCH = MODIFY SETTING

- Turns the demo play sound ON or OFF.
- ALL THE TIME-----Sound always ON
- ONCE EVERY 4 CYCLES ----- Sound ON every 4 cycles
- COMPLETELY OFF--Sound always OFF
- You will hear a do-re-mi musical scale from the left external speaker and then the right external speaker, which is repeated twice.
- Adjusts the volume from the level 0 (no volume) to 30 (Max.)
- Returns all the settings to the factory settings at the time of shipment.

GAME OPTIONS

(Game settings)

■ The following screen appears when this mode is selected.

!

● When game machines are networked, make sure that the PCB settings are the same on all the units.

GAME OPTIONS

NOVICE COURSE
 DIFFICULTY LEVEL 4/MEDIUM
 SETTING FOR NUMBER OF LAPS 3
 EXPERT COURSE
 DIFFICULTY LEVEL 4/MEDIUM
 SETTING FOR NUMBER OF LAPS 3
 PRO COURSE
 DIFFICULTY LEVEL 4/MEDIUM
 SETTING FOR NUMBER OF LAPS 3
 SPEEDMETER DISPLAY km/h
 GAME JOINING PERIOD 15
 BONUS CREDIT FOR WINNER NO
 FACTORY SETTINGS
 SAVE AND EXIT
 EXIT

HANDLE LEFT/RIGHT = SELECT OPTION
 START/VIEW SWITCH = MODIFY SETTING

- Difficulty level settings (8 levels)
 1/EASIEST Very easy
 2/VERY EASY
 3/EASY
 4/MEDIUM ----- Medium
 5/MEDIUM HARD
 6/HARD
 7/VERY HARD
 8/HARDEST Very difficult
- Lap number settings (2 to 5 laps)
- You can set the difficulty level and number of laps for each course.
- Changes the speedometer display. [Km/h] or [MPH]
- Sets the game joining period length. (5, 10, 15 or 20))
- If "YES" is selected, a game is awarded to the winner who has reached the goal and come out first in a 4-participant network game.
- Returns all the settings to the factory settings at the time of shipment.

COIN OPTIONS

(Coin settings)

■ The following screen appears when this mode is selected.

! ● Note that the coin setting options are not displayed when FREE PLAY is set to "YES".

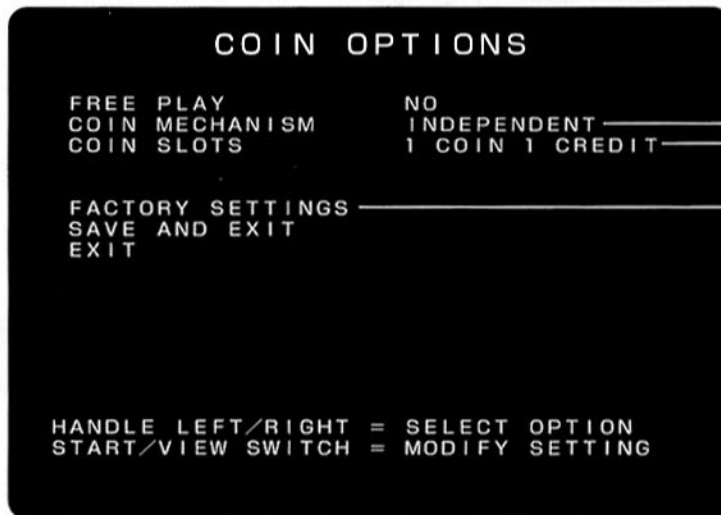

- Always keep it set to INDEPENDENT.
- Sets the relation between the number of coins and the number of credits.
- When FREE PLAY is set to YES, COIN MECHANISM and COIN SLOTS options are not displayed.
- Returns all the settings to the factory settings at the time of shipment.

The relation between the number of coin(s) and the number of credits.

SETTING	1	2	3	4	5	6	7	8	9	10	11	12	13	14	15	16	17	18	19	20	21	22	23	24	25	26	27	28	29	30	31	32
COIN(S)	1	1	1	1	1	1	1	2	2	2	3	3	3	4	4	4	5	5	6	5	7	7	8	8	9	10	11	12	13	14	15	16
CREDIT(S)	1	2	3	4	5	6	7	1	3	5	1	2	4	1	3	5	1	2	1	5	1	2	1	3	1	1	1	1	1	1	1	1

5-6 Measures to be taken when “DRIVING SYSTEM ERROR” is displayed

If the “DRIVING SYSTEM ERROR” message appears on the screen, take the following measures.



- If the same symptom persists after taking necessary measures or a problem not covered in this manual occurs, immediately turn off the power switch to stop operating the machine.

Symptom 1 “DRIVING SYSTEM ERROR” message appears on the screen.



Possible causes and measures to be taken — — — — —

Possible causes	Measures
<ul style="list-style-type: none"> ● The machine body has received or is receiving too heavy load or too strong impact during operation. (Refer to error code list “DRIVING SYSTEM ERROR” on page 41.) 	<ul style="list-style-type: none"> ○ When any of the error codes 1 to 16 is displayed, turn off the power switch immediately. ○ When any of the error codes 17 to 25 is displayed, turn off the power switch after waiting for more than 3 minutes and turn on

5-7 Measures to be taken when there is a network abnormality

If the “NETWORK ERROR” message appears, if any item responds incorrectly in the network communication check described on pages 18 and 19, or if the projector displays differ from the specified ones, take the following measures.



- If the same symptom persists in spite of taking measures or a problem not covered in this manual occurs, immediately turn off the power switch to stop operating the machine.

Symptom 1 The “NETWORK ERROR” message appears on the screen after the power is turned on.

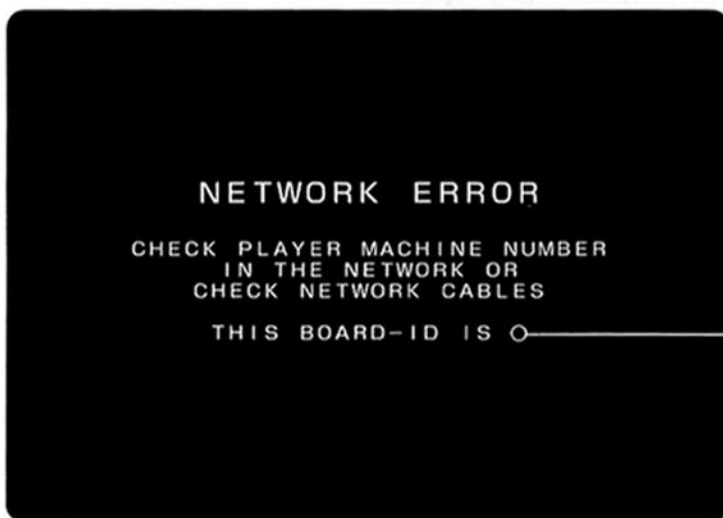

Shows the “Network ID” of the game machine.
(A number from 1 to 4)

■ Possible causes and measures to be taken

Possible causes	Measures
<ul style="list-style-type: none"> ● The main board DIP switch “Network ID” settings are improper. 	<ul style="list-style-type: none"> ○ Set the DIP switch properly. (See page 20.)
<ul style="list-style-type: none"> ● One of the networking cords used is disconnected from the game machine. 	<ul style="list-style-type: none"> ○ Properly connect the networking cords between the game machines. Make sure that the pin jacks that are not in use are free of dust or dirt.
<ul style="list-style-type: none"> ● A networking cord is connected to the first pin jack of the first game machine or the second pin jack of the last game machine. 	<ul style="list-style-type: none"> ○ Disconnect the networking cord connected to the first pin jack of the first game machine or the second pin jack of the last game machine. (See page 13.)

Symptom 2 The "NETWORK ERROR" message appears on the screen during playing.

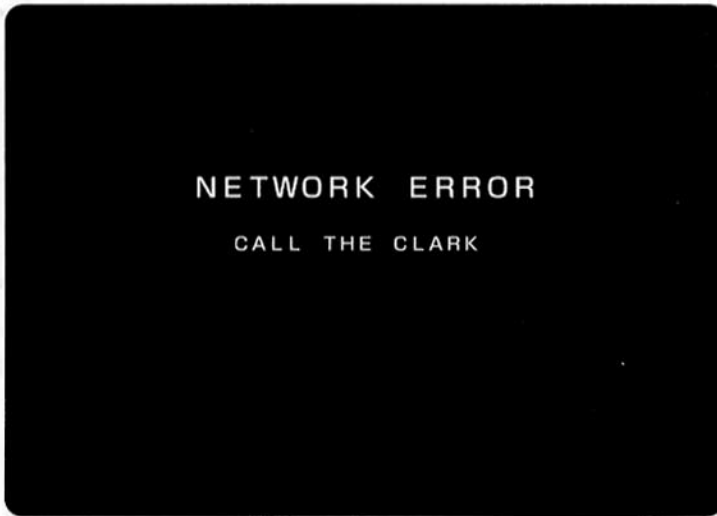

■ Possible causes and measures to be taken

Possible causes	Measures
<ul style="list-style-type: none"> ● One of the networking cords has been disconnected from the game machine during play. 	<ul style="list-style-type: none"> ○ 1. Turn OFF the power switch. ○ 2. Connect the networking cord properly. ○ 3. Turn ON the power switch.
<ul style="list-style-type: none"> ● One of the networking cords has been internally broken or broken. 	<ul style="list-style-type: none"> ○ Replace the networking cord with the spare networking cord. (You can also use commercially-sold video cable (75 Ω 3C-FV) having a length of 2m(78.74in) or less.)
<ul style="list-style-type: none"> ● The test switch (on the service panel) of one of the networked game machines has been pressed. <div style="border: 1px solid black; padding: 5px; margin-top: 10px;"> <p style="text-align: center;"></p> <ul style="list-style-type: none"> ● The test switch should be pressed during the game mode demo of all the networked game machines. </div>	<ul style="list-style-type: none"> ○ 1. Turn OFF the power switches of all the networked game machines. ○ 2. Close the maintenance door.
<ul style="list-style-type: none"> ● Any of the machines which are connected through the network have different game option settings (in the manual test). 	<ul style="list-style-type: none"> ○ Enter the manual test mode and set for the same game options among all the machines.

6 Setting up the

6-1 Connecting the units

■ How to connect the units



- Install the billboard with 2 or more people by using a stool.
- Do not move the machine after connecting each unit.

- 1** Remove the joint plate attached to the projector unit and the screws at the main unit connection side.

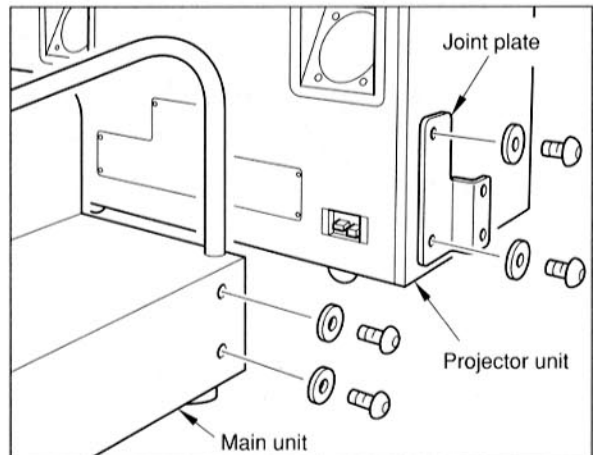

- 2** Place the projector unit where you want to set it and install the joint plate in the direction as shown in the figure.

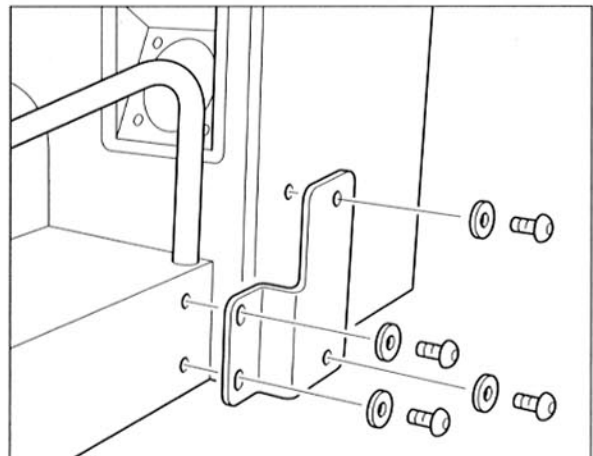

- 3** Connect the main unit and install the joint plate temporarily.

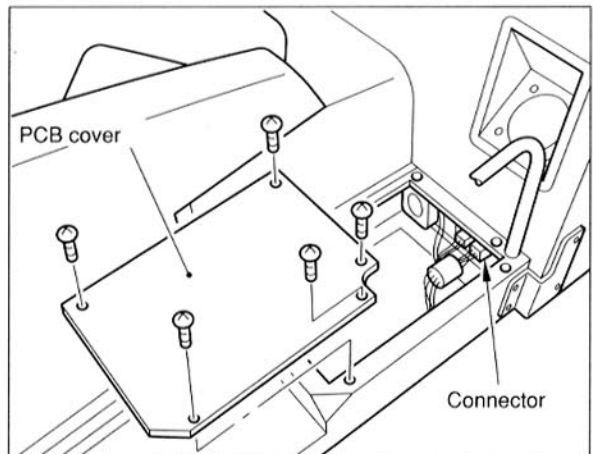

- 4** Remove the PCB cover from the main unit.

- 5** Cut the insulator lock fastening the connecting wires and remove the connector.

6 | Connect the connector to the projector unit side

7 | Reinstall the PCB cover onto the original position.

8 | Fasten the adjusters, referring to “Fastening adjusters” on page 28. Securely tighten the joint plate which was temporarily tightened.

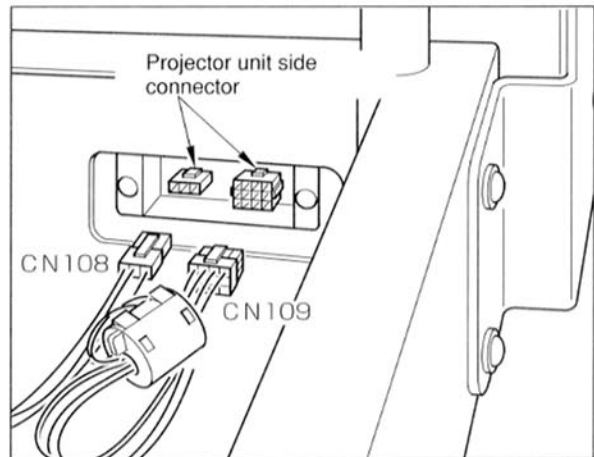

9 | Remove the connector from the billboard bottom surface.

10 | Remove the title unit locking screws (4 pcs.) from the top surface of the projector unit.

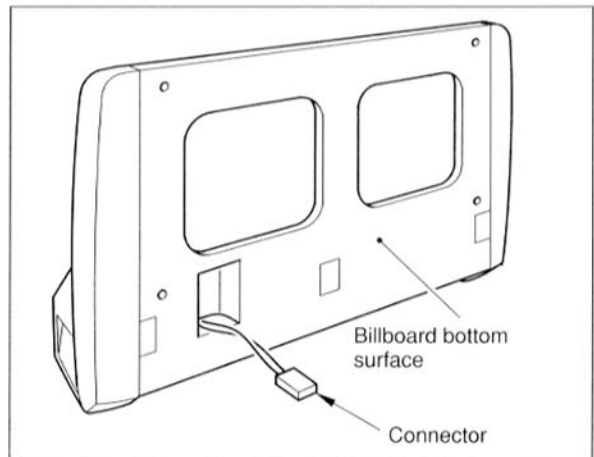

11 | Lift the billboard and connect the connector to the projector unit side. Fasten the billboard with the screws removed in step 10, being careful not to catch the bound wires.

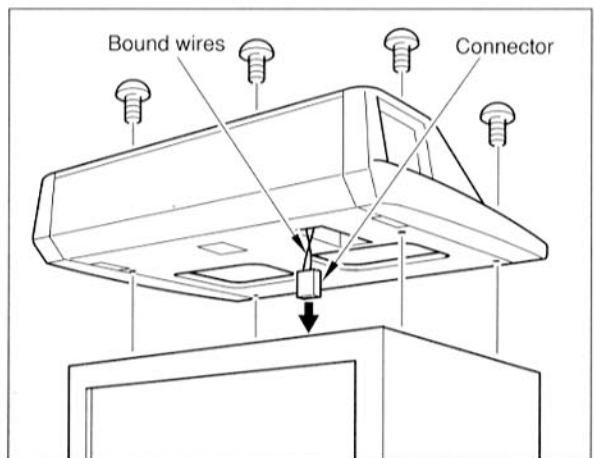

6-2 Fastening the adjusters

■ How to fasten the adjusters



- Adjust the adjusters so that the casters do not touch the floor. Take care not to exceed the maximum adjusting height of the adjuster.
- After checking that all the adjusters stand on the floor and the units do not wobble, tighten the hexagon nuts upward.

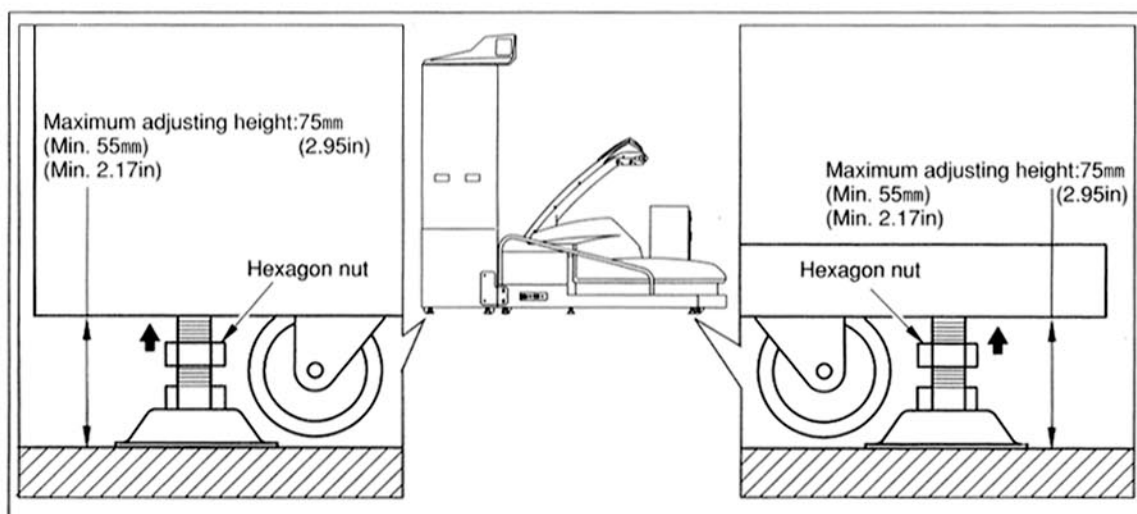

6-3 AC bracket

■ AC bracket

The AC bracket is located on the left side of main unit.

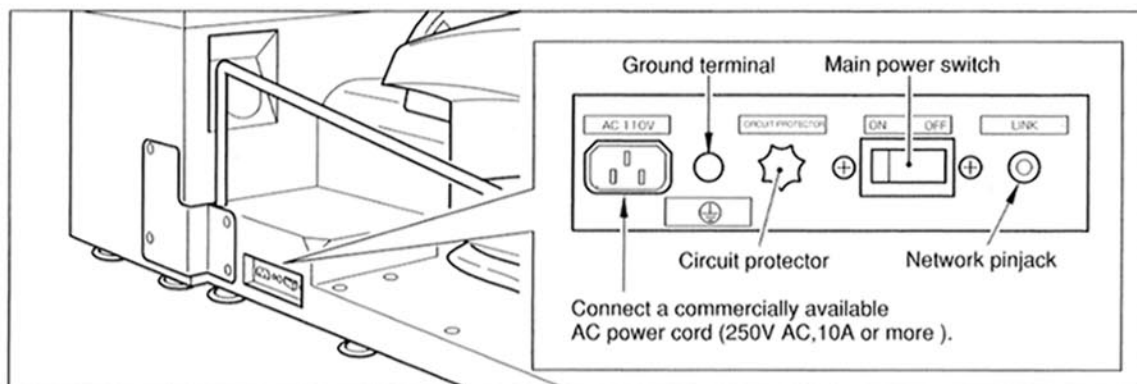

6-4 Service panel

■ Service panel

You will find the service panel when the maintenance door is opened with the attached maintenance key.

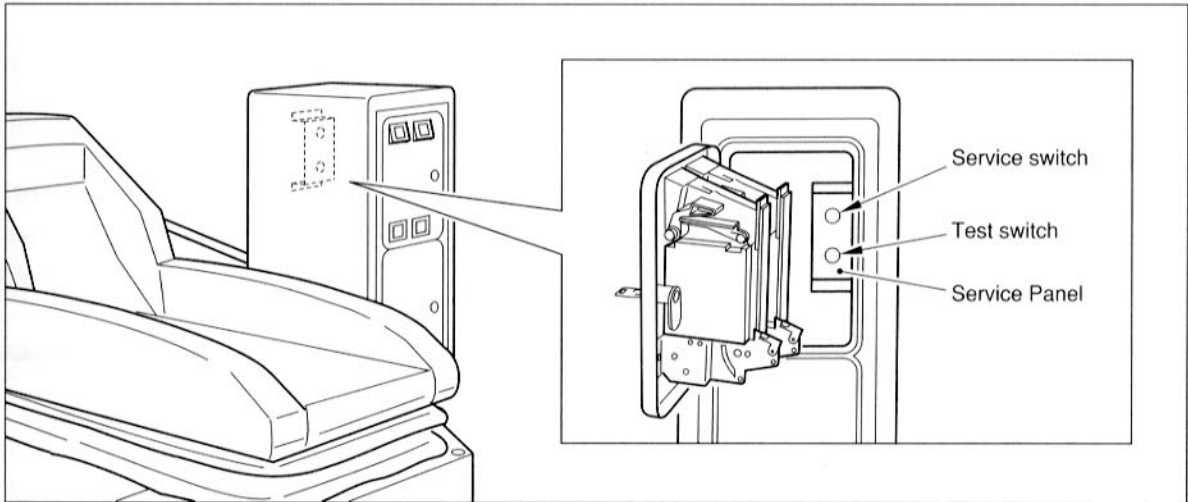

6-5 Separating and moving the units

The units of the machine can be separated.

■ How to remove the units



- Move the game machine, after making sure that the Main unit and projector unit are removed separately.
- Before separating each unit from the machine, be sure to turn off the power switch and remove the power cord plug from the receptacle.
- When connecting the separated units, take care not to catch the wiring or your hand between the units.

- 1 Turn off the power switch and remove the power cord plug from the receptacle.

- 2 Remove the PCB cover and disconnect the connector.

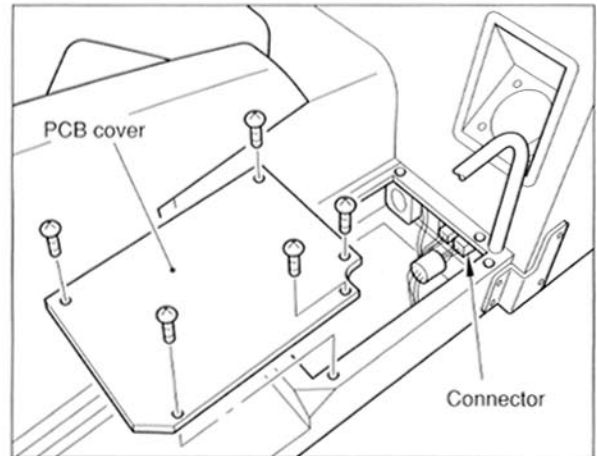

- 3 Separate the main unit from the projector unit in the reverse order of connection.

- 4 Loosen all adjusters and move each unit using casters.

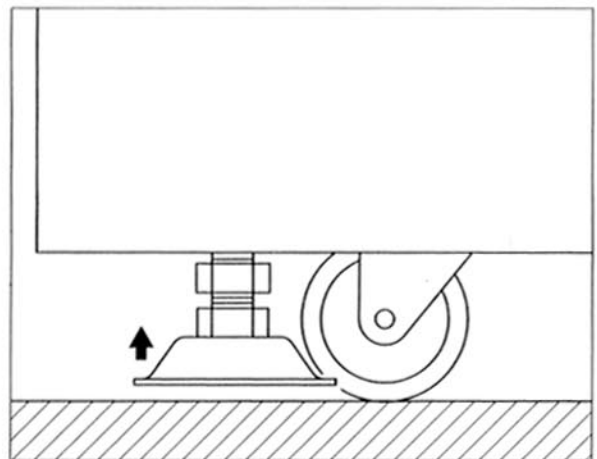

7. Maintenance and annex

7-1 Replacing the coin selector



- Be sure to turn off the power switch and remove the power cord plug from the receptacle before replacing the coin selector.
- Make sure that the main body is locked before replacing the coin selector.

- 1 | Open the maintenance door.
- 2 | Turn the stopper clockwise to release.
- 3 | Remove the plate holding the coin selector from the bottom side.
- 4 | Holding its front side take the coin selector out in the direction of the arrow.

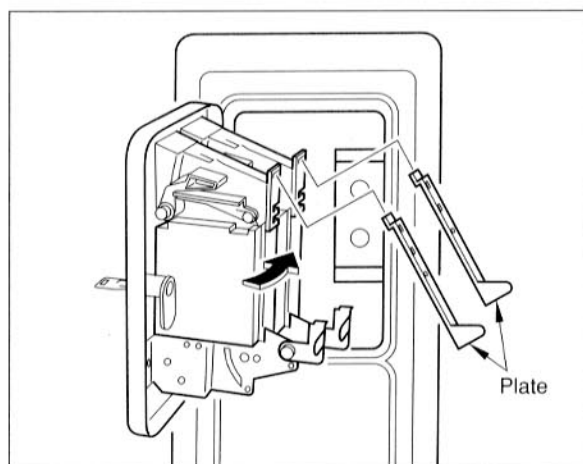
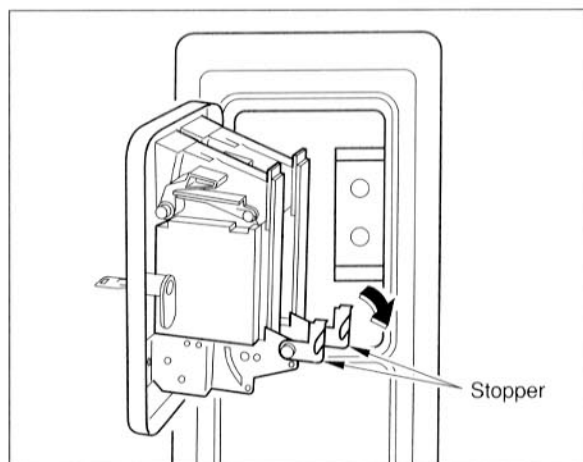

7-2 Replacing the fluorescent light



- Be sure to turn off the power switch and remove the power cord plug from the receptacle before replacing the fluorescent light.
- The fluorescent light is hot just after it is put off. Wait until it cools down and then replace it with a new one of the same type (straight tube 32 W/100V).
- When removing or installing the fluorescent light unit, take care not to catch the wiring between the fluorescent light unit and the main unit.

- 1 Remove the screws fixing the fluorescent light unit in the upper portion of the billboard, and remove the fluorescent light unit.

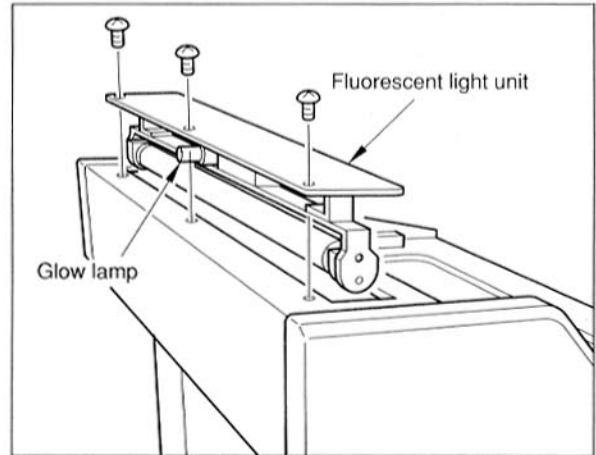

- 2 Push one end of the fluorescent light in the direction of the socket. The other end of the fluorescent light will be detached from the opposite socket.

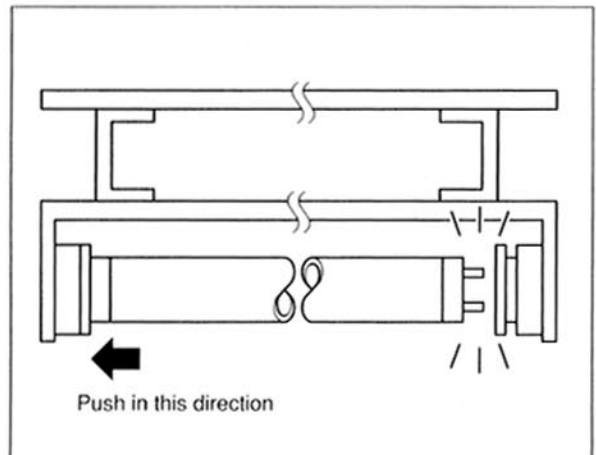

- 3 Install a new fluorescent light in the reverse order.

It is recommended that the glow lamp should be also replaced.

MEMO

7-3 Replacing the start/view switch (lamp)

■ How to replace the start/view switch (lamp) ————



- Turn off the power switch and remove the power cord plug from the receptacle before replacing the start/view switch (lamp).
- Make sure that the main body is locked.

- 1 | Remove the beam cover, being careful not to pull the wires.
- 2 | Take out the switch and the lamp receptacle from the back side of the beam.
- 3 | Replace the parts.
- 4 | Install the switch and the lamp receptacle in the reverse order of removal.

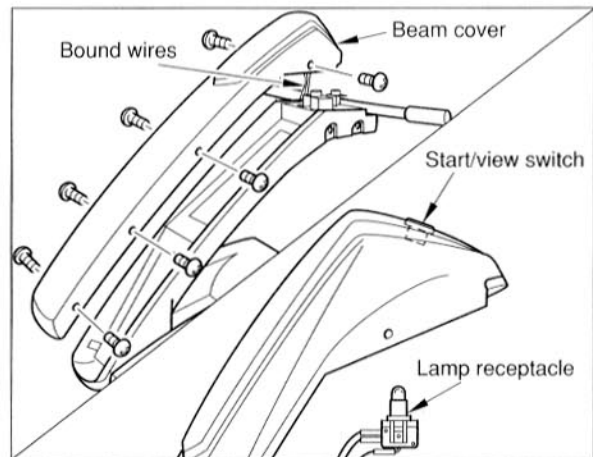

7-4 Replacing and adjusting the volume knobs

■ How to replace the volume knobs ————



- Turn off the power switch and remove the power cord plug from the receptacle before replacing the volume knobs.
- Make sure that the main body is locked.

- 1 | Remove the beam cover.
- 2 | Do not confuse the steering bar volume knob with the accelerator volume knob.

Before installing new volume knobs, adjust them referring to the procedures described on page 34.

MEMO

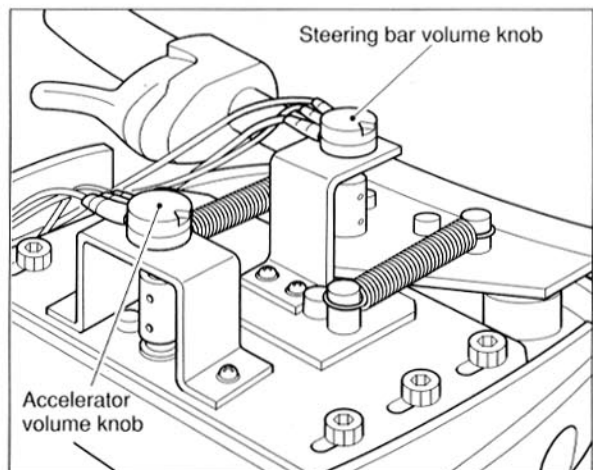

- 3 Remove the wires and loosen the hexagon socket head screw.
- 4 Remove the screws fastening the bracket and remove the volume knob with the bracket.
- 5 Remove the hexagon nut and take the volume knob out.

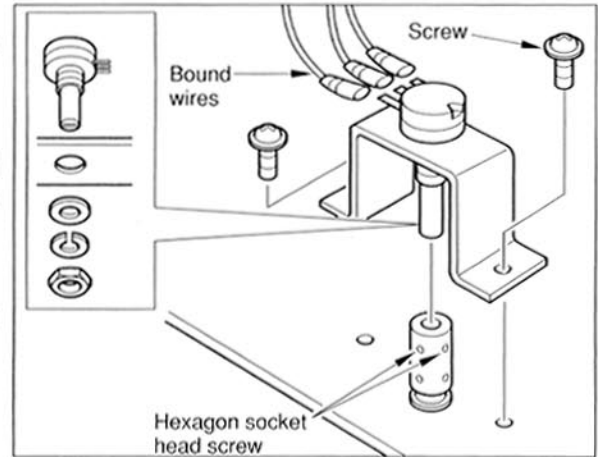

How to adjust the volume knob



Be sure to perform "5-3. PCB start-up check (self test)" on page 14 after replacing the volume knob.

- 1 Attach a new volume knob to the bracket.
- 2 Connect the wiring properly.

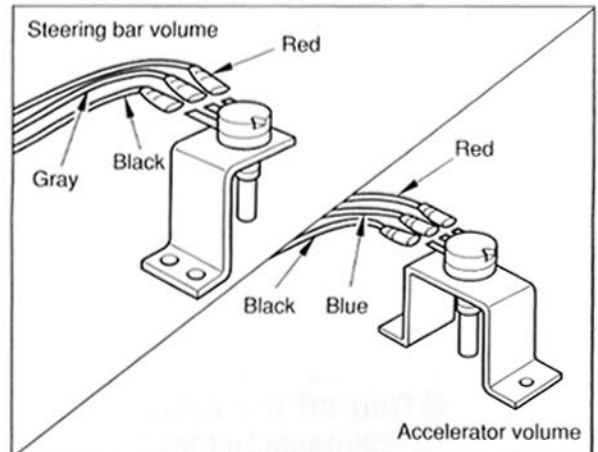

- 3 Grasp the volume knob tip with your fingers and adjust it as shown in the figure.
- 4 Install the bracket and securely tighten the hexagon socket set screws.

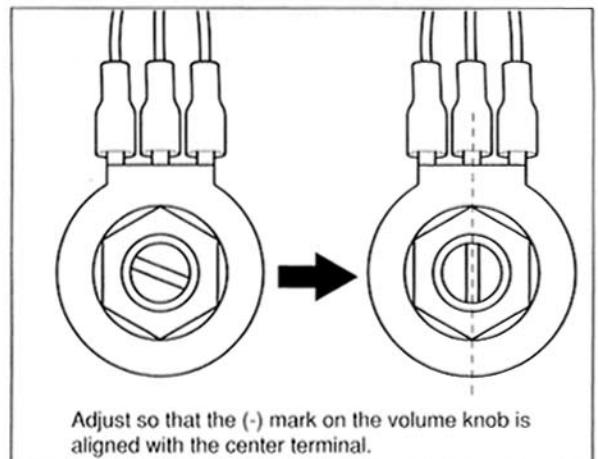

7-5 Replacing the belt and adjusting the belt tension

How to replace the belt



- Turn off the power switch and remove the power cord plug from the receptacle before replacing the belt.
- Make sure that the main body is locked.

- 1** Remove the right and left motor covers.

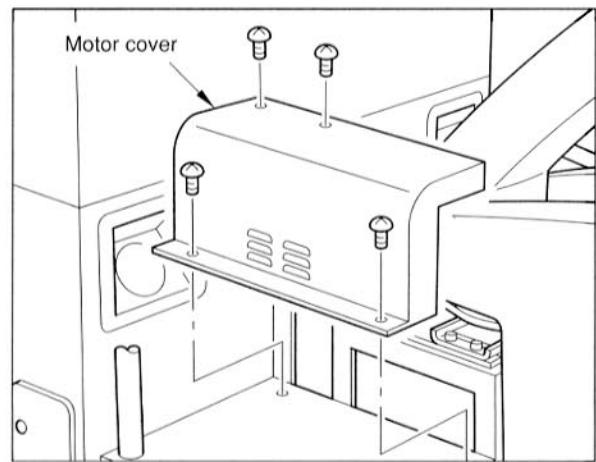

- 2** Loosen the adjuster lock nuts and the adjuster bolts on the right and left sides of the motor bracket.

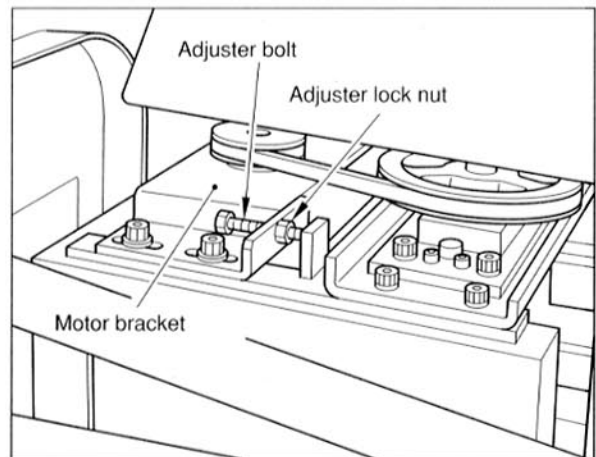

- 3** Loosen the hexagon socket head bolts (4 pcs.) fastening the motor bracket and remove the belt.

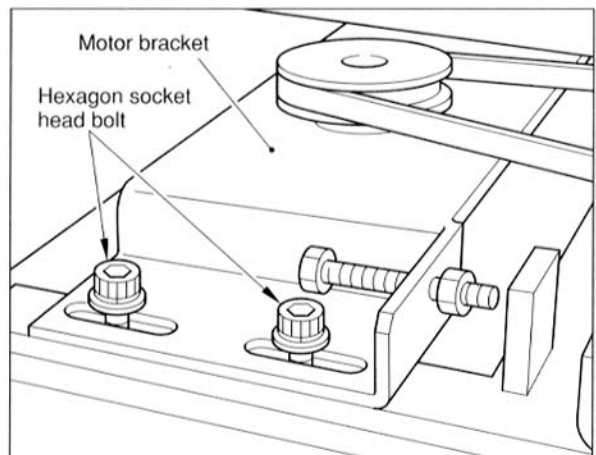

Adjust the belt tension according to the procedure described on page 36, after replacing the belt with a new one.

MEMO

■ How to adjust the belt tension



- Make sure that the belt is securely placed in the groove of both pulleys before adjusting the belt tension.
- Tighten the right and left adjuster bolts evenly.
- Do not lubricate the belt and pulleys.

- 1 Remove the right and left motor covers.
- 2 Loosen the hexagon socket head bolts (4 pcs.) fastening the motor bracket.

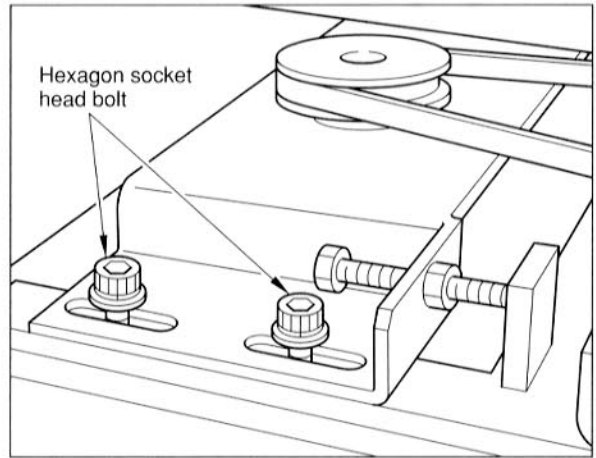

- 3 Tighten the adjuster bolts evenly on the right and left sides of the motor bracket and adjust the belt tension correctly.

Correct deflection of the belt

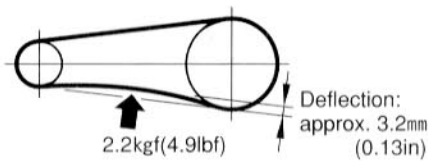

Note:
Using a commercial tension gauge may make it easy to adjuster bolt tension.

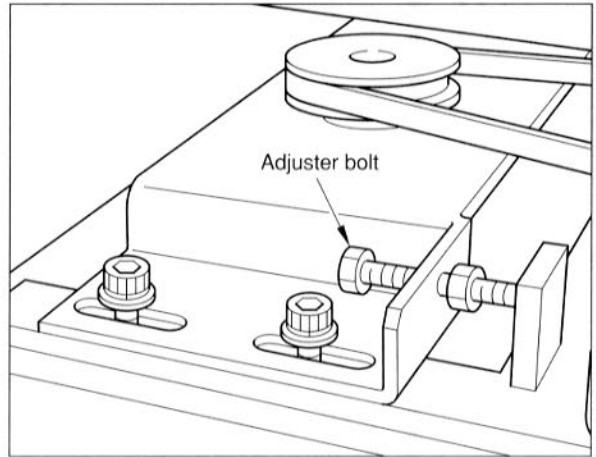

- 4 Tighten the hexagon socket bolts (4 pcs.) and tighten the adjuster lock nuts.

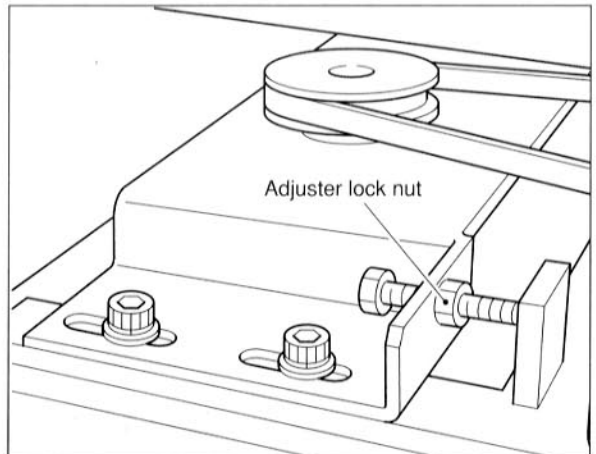

- 5 Install the right and left motor covers in this order.

7-6 Adjusting the projector



- The interior of the projector contains high voltage electricity, so take great care not to touch it.

■ Projector adjustment PCB

The projector adjustment PCB is located inside the projector maintenance door of the projector unit. (Remove the screws and open the door with the maintenance key.)

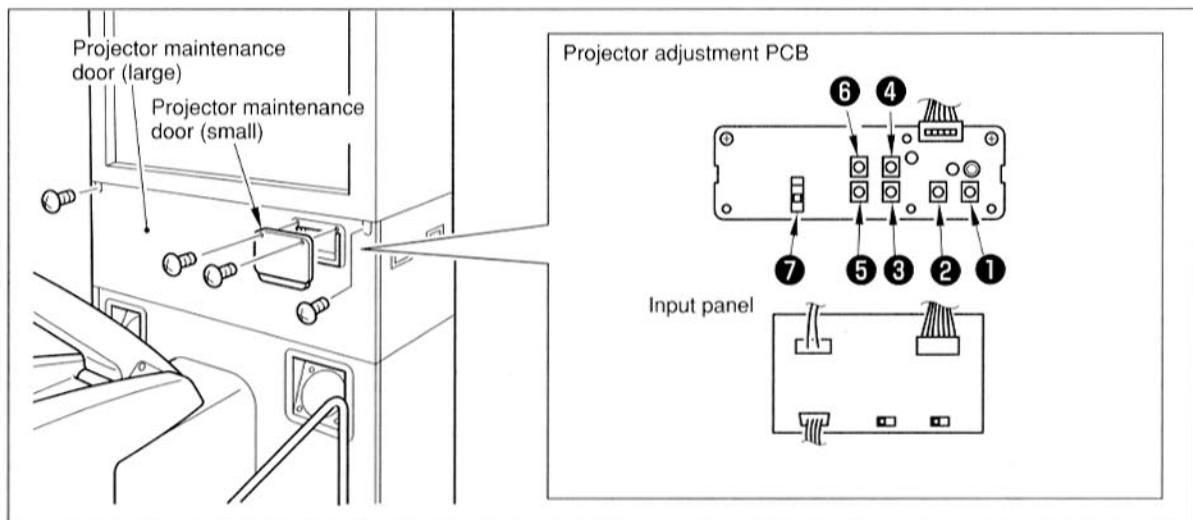

①	CONTRAST	Contrast adjustment Used to change the contrast.
②	BRIGHT	Brightness adjustment Used to change the brightness. Turning it clockwise will make the image brighter.
③	H.POSI	Horizontal screen position adjustment Used to change the raster position in the horizontal direction.
④	V.POSI	Vertical screen position adjustment Used to change the raster position in the vertical direction.
⑤	H.SIZE	Horizontal screen size adjustment Used to change the width of the screen.
⑥	V.SIZE	Vertical screen size adjustment Used to change the height of the screen.
⑦	CONV.ADJ. (CONVERGENCE)	Static convergence adjustment Used to adjust misconvergence caused by the earth's magnetic field, etc. (Be sure to keep this off when not adjusting.) Refer to page 38 for the adjusting method.

When the game machine is moved to another location or reoriented, screen color distortion can occur due to magnetism from objects near the game machine or from the earth's magnetic field. If screen color distortion occurs uniformly across the whole screen, adjust static convergence in the following way.

■ How to adjust static convergence



- Be sure to keep the [CONV.ADJ.] switch off when not adjusting. After the completion of adjustment, check that the [CONV.ADJ.] switch is turned off.
- When using the remote control, keep it within a 30° angle to the top, bottom, left and right of the center of the screen and stand no further than 3 meters(118inches) away from the screen.
- When the [RESET] key is pressed during adjustment, setting to the status before adjustment is performed.
- If the screen is extremely disturbed due to static electricity, etc. during adjustment, turn off the power switch and then turn it on.
- If the remote control does not work properly, replace the batteries with new ones. If the remote control is not to be used for a long time, remove the batteries from the remote control. Failure to do so could cause liquid leakage.

1 Turn ON the [CONV.ADJ.] switch on the projector control PCB.

2 Point the remote control at the screen and press the [TEST] key for about 3 seconds.
(A green cross pattern appears on the screen.)

3 Press the [R] key on the remote control.
(A red cross pattern appears on the screen along with the green cross pattern and the frame turns red.)

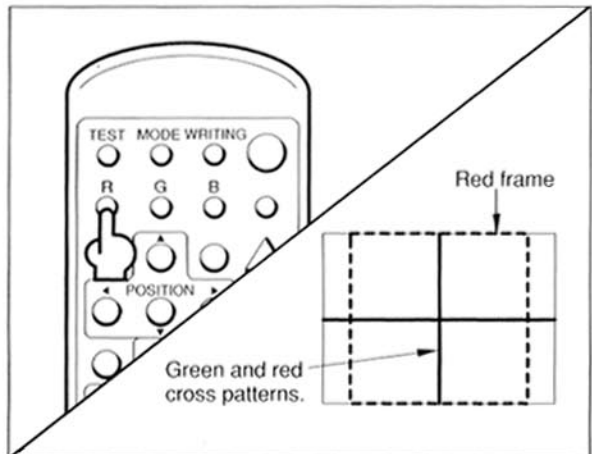
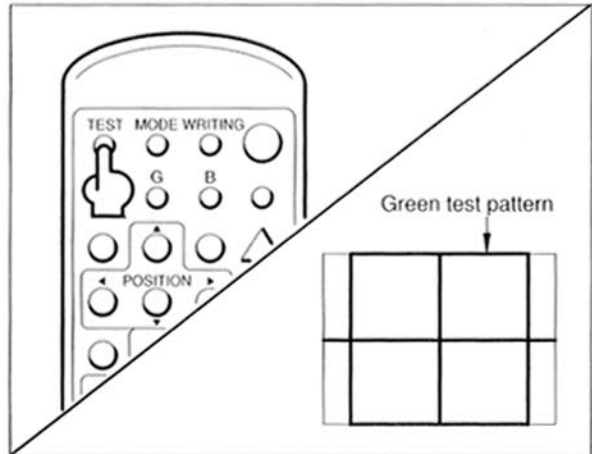

- 4** Using the [ADJUST] keys on the remote control, align the center of the red cross with the center of the green cross. (When the red cross is superimposed on the green cross, the resultant cross looks yellow.)

Move the red cross (not the green cross) for adjustment.

MEMO

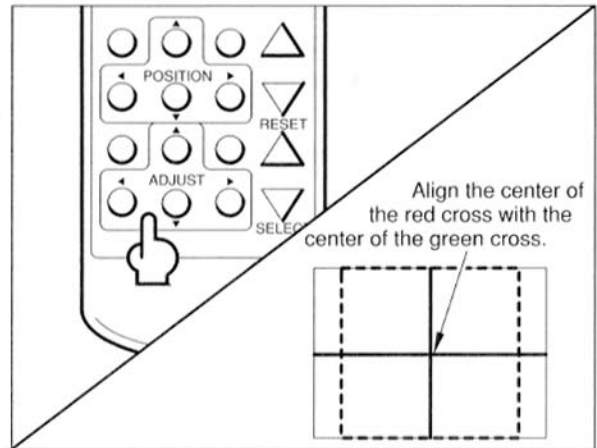

- 5** Press the [B] key on the remote control. (A blue cross pattern appears on the screen along with the yellow cross pattern and the frame turns blue.)

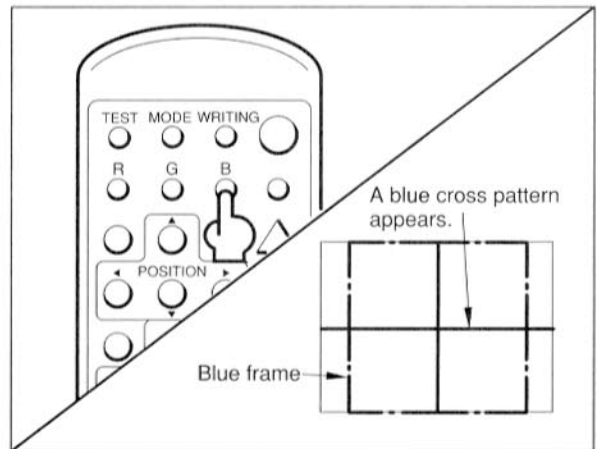

- 6** Using the [ADJUST] keys on the remote control, align the center of the blue cross with the center of the yellow cross. (When the blue cross is superimposed on the yellow cross, the resultant cross looks white.)

Selecting red again after adjusting blue will make the red disappear, so select a second time. (Do the same when adjusting blue again after red.)

MEMO

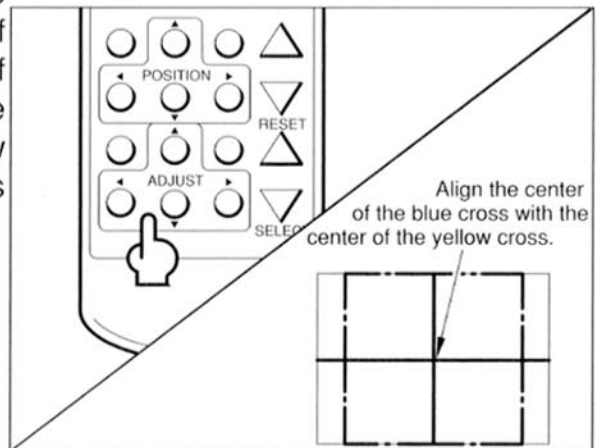

- 7** Press the [WRITING] key on the remote control to save the adjustments.

- 8** Turn OFF the [CONV.ADJ.] switch on the projector control PCB.

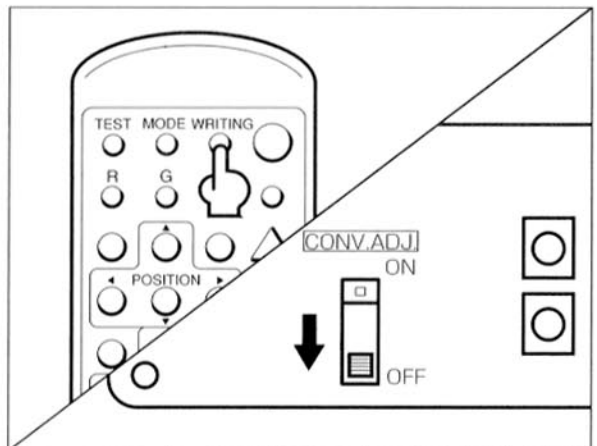

If a partial color drift is found, perform static convergence adjustment in the following procedure:

■ How to perform partial static convergence adjustment — — — — —

- 1 | Turn on the [CONV.ADJ] switch on the projector control PCB.
- 2 | Point the remote control toward the screen and press the [TEST] key for about 3 seconds. (A green checked pattern appears on the screen.)
- 3 | Press the [MODE] key on the remote control.
 (Each pressing of the [MODE] key changes the mode in the following order:static adjustment→one-row adjustment→one-point adjustment---. Select one of the modes according to the color drift condition. Here, we will describe the procedure for carrying out partial static convergence adjustment, assuring that the one-point adjustment mode has been selected: The screen shows a green checked test-pattern and the marker indicating the place to be adjusted.)

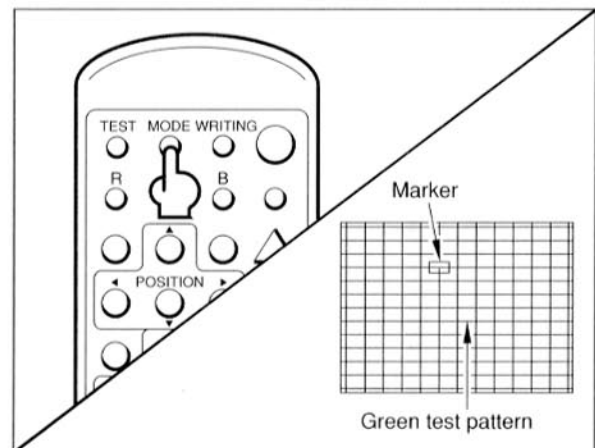

- 4 | Press the [R] key on the remote control.
 (A red test pattern appears on the screen along with the green test pattern,and the green marker turns red.)
- 5 | Press the [POSITION] keys on the remote control to move the marker to the place you want to adjust. (The range where the marker can move is limited.)
- 6 | Press the [ADJUST] keys on the remote control to match the red test pattern with the green one. (When the red test pattern is laid over the green one, the resultant test pattern looks yellow.)
- 7 | Press the [B] key on the remote control.
 (The blue test pattern is added to the screen and the red marker turns blue. Adjust the blue color according to the procedure described in steps 5 and 6.)
- 8 | Store the adjustment condition by pressing the [WRITING] key on the remote control.
- 9 | Turn off the [CONV.ADJ.] switch on the projector control PCB.

MEMO

7-7 Error code list

■ Error code and description of “DRIVING SYSTEM ERROR” — — — — —



- When any of the error codes 1 to 16 is displayed, turn off the power switch immediately.
- When any of the error codes 17 to 25 is displayed, turn off the power switch after waiting for more than 3 minutes and turn on the power switch again.

Error code	Description
1	All sensors are ON. Sensors are defective.
2	[L-Limit] sensor, [Run-Limit] sensor and [N] sensor are ON. 2 or 3 of the sensors above are defective.
3	[L-Limit] sensor, [Run-Limit] sensor and [U-Limit] sensor are ON. 2 or 3 of the sensors above are defective.
4	[L-Limit] sensor, [N] sensor and [U-Limit] sensor are ON. 2 or 3 of the sensors above are defective.
5	[N] sensor, [Run-Limit] sensor and [U-Limit] sensor are ON. 2 or 3 of the sensors above are defective.
6	[L-Limit] sensor and [Run-Limit] sensor are ON. Either or both of the sensors above are defective.
7	[L-Limit] sensor and [N] sensor are ON. Either or both of the sensors above are defective.
8	[L-Limit] sensor and [U-Limit] sensor are ON. Either or both of the sensors above are defective.
9	[Run-Limit] sensor and [N] sensor are ON. Either or both of the sensors above are defective.
10	[Run-Limit] sensor and [U-Limit] sensor are ON. Either or both of the sensors above are defective.
11	[N] sensor and [U-Limit] sensor are ON. Either or both of the sensors above are defective.

Error code	Description
12	Neither [Run-Limit] sensor or [N] sensor respond. [L-Limit] sensor and [U-Limit] sensor are normal. [Run-Limit] sensor and [N] sensor are defective.
13	[Run-Limit] sensor does not respond. [L-Limit] sensor, [N] sensor and [U-Limit] sensor are normal. [Run-Limit] sensor is defective.
14	[N] sensor does not respond. [L-Limit] sensor, [Run-Limit] sensor and [U-Limit] sensor are normal. [N] sensor is defective.
15	[RIGHT TURN] switch and [LEFT TURN] switch are ON. Either or both of the switches above are defective.
16	When the machine is lowered to the bottom, the [T-CENTER] switch is not turned ON. [T-CENTER] switch or the machine is defective.
17	[L-Limit] sensor does not respond. The conditions of the other sensors are not clear. If this error code is displayed with the machine lowered to the bottom, the [L-Limit] sensor or the motor is defective.
18	[L-Limit] sensor is ON. Any of [Run-Limit] sensor, [N] sensor and [U-Limit] sensor does not respond. If the machine can be moved, the sensors or the motor might be defective.
19	[Run-Limit] sensor is ON. Any of [L-Limit] sensor, [N] sensor and [U-Limit] sensor does not respond. If the machine can be moved, the sensors or the motor might be defective.
20	[N] sensor is ON. Any of [L-Limit] sensor, [Run-Limit] sensor and [U-Limit] sensor does not respond. If the machine can be moved, the sensors or the motor might be defective.
21	[U-Limit] sensor is ON. Any of [L-Limit] sensor, [Run-Limit] sensor and [N] sensor does not respond. If the machine can be moved, the sensors or the motor might be defective.
22	Any of [Run-Limit] sensor, [N] sensor and [U-Limit] sensor does not respond. [L-Limit] sensor is proper. If this error code is displayed with the machine raised to the top, the [Run-Limit] sensor, [N] sensor and [U-Limit] or the motor might be defective.
23	Neither [N] sensor or [U-Limit] responds. [L-Limit] sensor and [Run-Limit] sensor are normal. If this error code is displayed with the machine raised to the top, the [N] sensor and [U-Limit] sensor or the motor might be defective.
24	[U-Limit] sensor does not respond. [L-Limit] sensor, [Run-Limit] sensor and [N] sensor are normal. If this error code is displayed with the machine raised to the top, the [U-Limit] sensor or the motor might be defective.
25	Neither [Run-Limit] sensor or [U-Limit] sensor responds. [L-Limit] sensor and [N] sensor are normal. If this error code is displayed with the machine raised to the top, both the [Run-Limit] sensor and [U-Limit] sensor are defective or the [Run-Limit] sensor and the motor are defective.

7-8 Wiring diagram

