



Trade Marks of Taito America Corporation

72-00001-001

# **“ZARZON”™-UPRIGHT**

## **TABLE OF CONTENTS**

### **1. ZARZON™ GAME SET-UP**

- A. Introduction
- B. Game Inspection
- C. Game Installation
- D. Dip Switch & Volume Control Settings

### **2. MAINTENANCE**

- A. Cleaning
- B. Fuse Replacement
- C. Video Monitor Removal
- D. Video Monitor Adjustments (Separate Manual) (72-00003-001)
- E. Fluorescent Bulb Replacement
- F. Printed Circuit Board Replacement

### **3. ILLUSTRATIONS AND PART LISTS**

- Figure 1 Video and Cabinet Assembly
- Figure 2 Coin Mechanisms and Front Door
- Figure 3 Switching Regulator & Cabinet Parts
- Figure 4 Control Panel
- Figure 5 Mounting Chassis Assembly
- Figure 6 CPU Board “A” & Component List
- Figure 7 CRT Controller Board “B” & Component List
- Figure 8 Option Switch & Volume Control Locations
- Figure 9 Wiring Diagram
- Figure 10 PC Board “A” Schematic (FOLD OUT)
- Figure 11 PC Board “B” Schematic (FOLD OUT)

## GAME SET-UP

### INTRODUCTION

TAITO AMERICA'S "ZARZON"™ is a video action game designed for one or two players.

The object of the game is to get your spaceship to Saturn, then once on Saturn to destroy as many Satan's as possible. Additional bonus points can be accumulated by destroying the comet or attacking dragonflies. An additional spaceship is awarded if the players score reaches 5,000 or 10,000 points. (adjustable)

If the attacking UFO's or enemy rockets are destroyed points will be scored. The game progresses through 4 different screens.

### GAME INSPECTION

TAITO AMERICA'S "ZARZON"™ game is ready to play when received. However, careful inspection is necessary to insure the game is in perfect condition. Please verify the following before turning the game on.

- \* Examine external parts for chips, dents, or broken parts.
- \* Open the service door and examine the following:
  - \* Plug-in connectors to make sure they are firmly seated.
  - \* Speakers
  - \* Player Controls
  - \* Printed circuit boards making sure there is no damage to the components.
  - \* Check for loose foreign objects especially metal objects which may cause electrical problems.
  - \* Fuses, making sure they are firmly in the holders.
  - \* Transformer
  - \* Coin Mechanisms

If problems occur or technical assistance is required, contact our Customer Service Department HOT LINE Toll Free 800-323-0666 (except Illinois). Illinois phone 981-1000 X 215.

The Video Monitor is properly adjusted before shipping. If there are any adjustments necessary refer to the Video Monitor Manual. (72-00003-001)

### POWER REQUIREMENTS

TAITO AMERICA'S "ZARZON"™ game is shipped ready for operation at 120VAC, 60Hz with a power consumption of approximately 250 Watts.

#### CAUTION

For safe operation it is recommended the cabinet be grounded. This game is equipped with a three conductor power cable. The third conductor is the ground conductor and when the cable is plugged into an appropriate receptacle, the game is grounded. The off-set pin on the power cable's three-prong connector is the ground connection.

#### LOCATION SPACE REQUIREMENTS

Depth - 35" (87.5cm)  
 Width - 24" (61cm)  
 Height - 68" (171cm)  
 Weight - 300 lbs. (135Kg)  
 (Packaged Weight)

### INSTALLATION REQUIREMENTS

The following precautions should be followed when installing the game.

- \* Avoid rough handling of the game, the picture tube is fragile.
- \* Install the game on a level surface.
- \* Avoid installing the game where it may receive excessive sunlight or heat, to prevent the game from rising internal temperature.
- \* Do not install in a damp or dusty location.
- \* For a short time after connecting the power to the game, the picture may be temporarily distorted.

### DIP SWITCH AND VOLUME CONTROL SETTINGS

#### DIP SWITCH SETTINGS

TAITO AMERICA'S "ZARZON"™ game provides the following option switches. See Figure 8. These options can be found on PC Board "A" Switch B.

#### NOTE

Remove power before making S.W. Adjustments.

SW1 should be kept in the ON position. The only time it would be in the OFF position would be for the cocktail table version.

SW2 and SW4 are for coin selection. These switches are preset at the factory for 1 coin - 1 play.

COIN SELECTION	SW2	SW4
1 coin - 1 play	OFF	OFF
1 coin - 2 play	ON	OFF
2 coin - 1 play	OFF	ON

TABLE 1 COIN SELECTION

- \* SW3 is used for additional bonus spaceships. Once the players score reaches the set bonus he is awarded an additional spaceship. This is preset at the factory at 5,000 points.

SW3	ON	5,000
	OFF	10,000

TABLE 2 BONUS POINT OPTION

- \* SW5 and SW6 are used for selecting the number of spaceships per game. These switches are preset at the factory for 4 spaceships.

SPACESHIPS	SW5	SW6
3	OFF	OFF
4	ON	OFF
5	OFF	ON

TABLE 3 SPACESHIP SELECTION

- \* SW7 & SW8 are not used at all and must be kept in the OFF position.

#### VOLUME CONTROL SETTING

- \* VR. A This control is used to control the volume of the total game and is found on PC Board "B". See Figure 8 volume goes down when turning as the arrow indicates.

## MAINTENANCE

All games require a certain amount of maintenance to keep them in good condition. A periodic check of mechanical controls would be beneficial to guarantee your game will be profitable.

## CLEANING

The exterior of the game, all metal parts and all plastic parts can be cleaned with a non-abrasive cleanser. Caution should be used when cleaning the plastic, a dry cloth can cause scratches and result in a foggy appearance.

## FUSE REPLACEMENT

This game uses six fuses, 5 are located on the Switching Regulator. See Figure 3 for size and part number of fuses. One fuse is located on the Power Supply itself.

## VIDEO MONITOR REMOVAL

If you need to remove the video monitor, follow the instructions listed below:

### CAUTION

It is recommended the game be left disconnected for at least one hour before removing the video monitor. This will probably discharge the video tube but extreme caution is still necessary.

- \* Remove power from line voltage.
- \* Disconnect the monitor and cable connector.
- \* Remove wire cable clamp.
- \* Take out the two side bolts, one on each side of the cabinet.
- \* Lower the monitor to rest on the lower set of wood supports.
- \* Remove the four mounting bolts and disconnect the green ground wire.
- \* Slide the monitor out by pulling the monitor towards you.

### CAUTION

Use extreme caution and do not touch electrical parts of the monitor yoke area with your hands or with any metal object in your hands! High voltages may exist in any monitor, even with power disconnected.

## VIDEO MONITOR ADJUSTMENTS

TAITO AMERICA CORPORATION presently uses either a Wells-Gardner Corp. or Electrohome Electronics 19" color video game monitor in the "ZARZON"™ upright game. Refer to the Monitor Manual for your specific video monitor. Be sure to heed all the WARNINGS and CAUTION INSTRUCTIONS provided before repairing or replacing your video monitor. (72-00003-001).

## FLOURESCENT TUBE REPLACEMENT

### CAUTION

If you drop a flourescent tube and it breaks it will explode! PLEASE USE CARE WHEN REPLACING.

\*Remove the three screws from the marquee bracket, being sure to hold the glass while removing the screws.

\*Remove marquee glass and the flourescent bulb is accessible.

\*With both hands turn the bulb toward you, carefully pull lamp out of lamp socket.

## PRINTED CIRCUIT BOARD REPLACEMENT

You may wish to remove the "ZARZON" printed circuit boards for replacement or repair. Follow the procedure below.

To remove "A" and "B" board, loosen the wing screw located on the top of the PCB Chassis. Then slide the stop bracket to the side and slide the PC board to be removed out of the guides.

### WARNING

This equipment generates, uses, and can radiate radio frequency energy and if not installed and used in accordance with the instruction manual, may cause interference to radio communications. As temporarily permitted by regulation it has not been tested for compliance pursuant to Subpart J of Part 15 of FCC Rules, which are designed to provide reasonable protection against such interference. Operation of this equipment in a residential area is likely to cause interference in which case the user at his own expense will be required to take whatever measures may be required to correct the interference.

## VIDEO AND CABINET ASSEMBLY

### FIGURE 1

ITEM	TAITO PART NO.	DESCRIPTION	REFERENCE
1	47C00001-002	Screened Acrylic Marquee Panel	400073
2	27-00001-001	Fluorescent Tube, Std., 15W	AA054711
3	42B00057-001	Fluorescent Lamp Panel	140006
4	26-00004-001	Lamp Socket (Holder)	113000
5	61C00007-001	Marquee Retainer	500024
6	26-00005-001	Starter Socket	114001
7	29-00003-001	Starter	114000
8	18-00002-001	Ballast Transformer (220V, 60Hz)	010001
9	61B00011-001	"L" Bracket	AAP13584
10	41B00002-002	Cabinet Assembly	
		or	
	41B00005-001	Cabinet Assembly	
11	63-00002-001	"T" Molding	400007
12	59-00008-001	Clamp Fastener	390002
13	47D00002-002	Cover Glass	
14	63C00003-001	Monitor Shroud	400005
15	61C00016-001	Glass Retaining Bracket	500022
16	44C00001-001	Wheel Assembly	520000
17	63B00005-002	"L" Molding, Black, 22½" Long	400031-A
18	63B00005-003	"L" Molding, Black, 33¾" Long	400031-B
19	31-00001-001	Wells Gardner Monitor, 19"	620006
19A	31-00001-002	Electrohome Monitor 19"	620007
20	60C00061-001	Video Monitor Bracket	500026
21	45-00001-001	Anchor Plate	600005-C
22	45-00001-001	Service Lock & Key	600005
23	42C00035-001	Cabinet Back	143003
24	61B00027-001	Grille	500074
25	500086	Mounting Bracket Top	AA013580
26	500088	Cash Box	AA028507
27	400050	Cash Case	AA028506
28	600007	Lock Plate	AA013593
29	500089	Cash Box Door	AA026512
30	600006	Lock (Cash Box) & Key	AA016545
31	500060	Coin Funnel	
32	500061	Coin Funnel Plate	AA013690
33	115000	Counter, 6V DC	AA013608
34	500091	Counter Bracket	
35	63B00006-004	U Channel	400025
36	500087	Bracket, Bottom	
37	36-00005-001	Counter Drive Credit Board	800011
38	25-00014-001	10 Position Edge Connector	
39	500035	Credit Board Bracket	
*40	07-00031-001	Chassis PCB Mounting	85008
*41	08-00004-001	PCB Set (Taito)	
*42	08-00006-001	PCB Set (SNK)	

\*Not Shown on Figure 1

# VIDEO AND CABINET ASSEMBLY

FIGURE 1

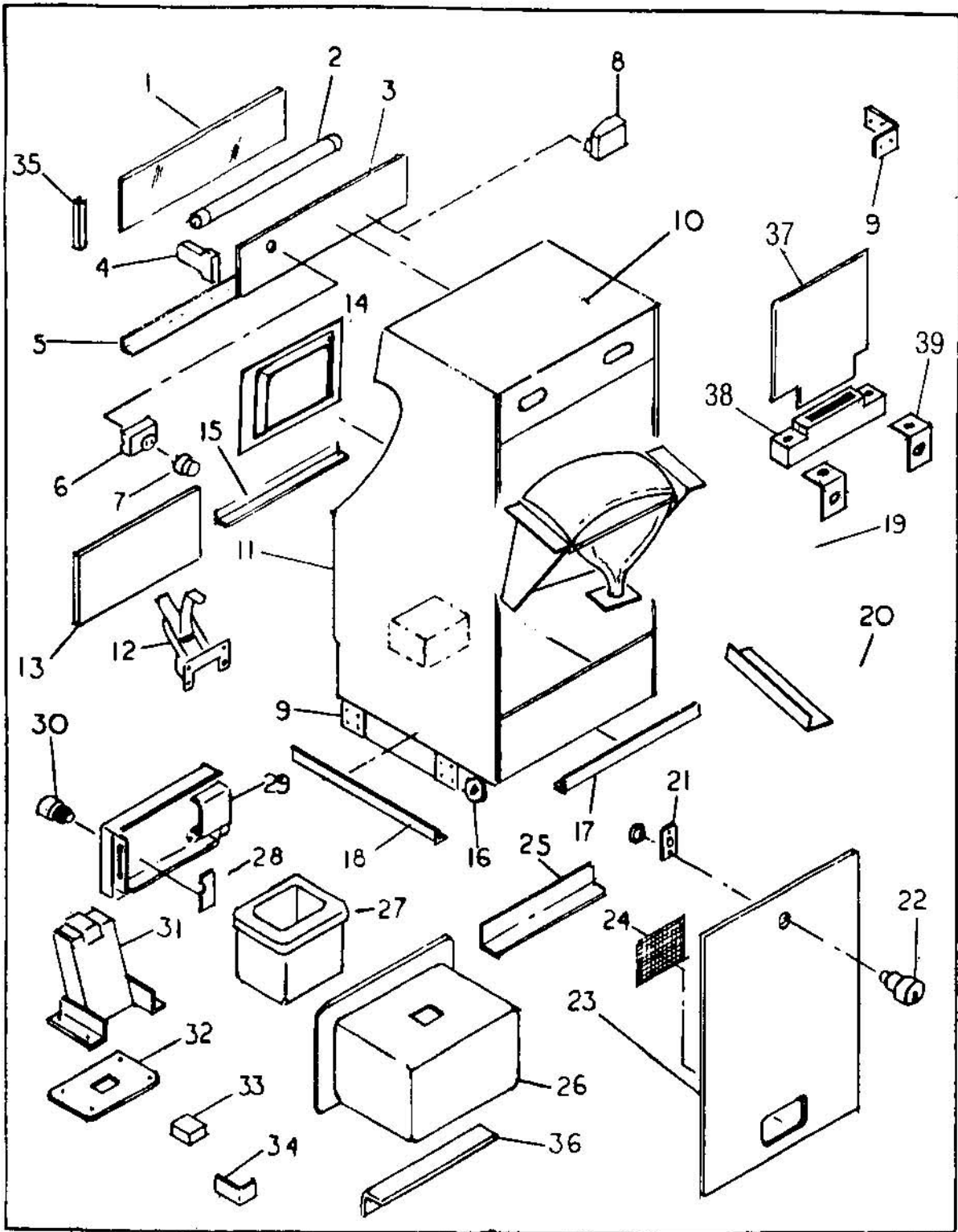

# COIN MECHANISM AND FRONT DOOR ASSEMBLY

FIGURE 2

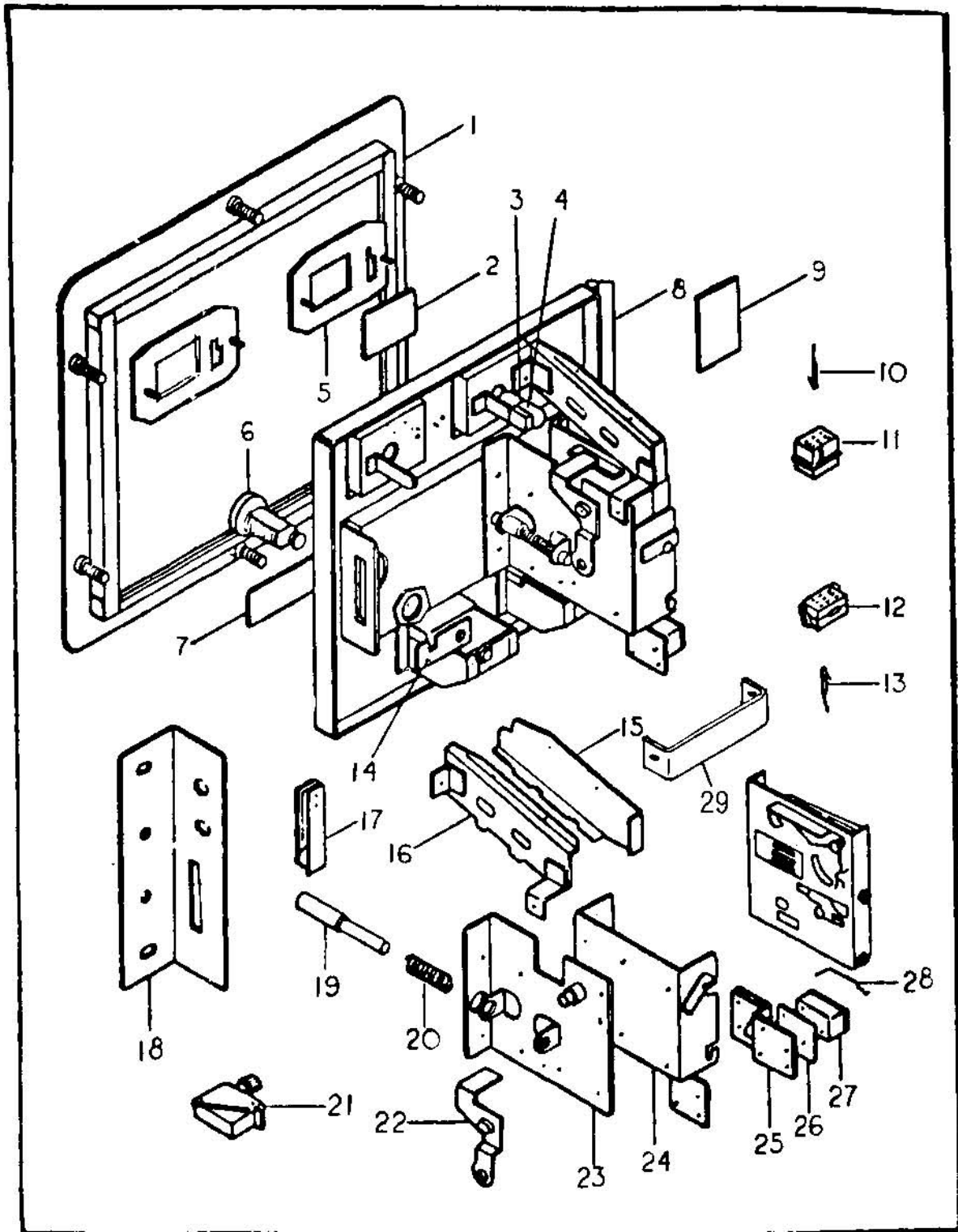

## SWITCHING REGULATOR & CABINET PARTS

FIGURE 3

ITEM	TAITO PART NO.	DESCRIPTION	REFERENCE
1	36-00004-001	Switching Regulator Assembly	800010
2	998702	Shield Box	AA013613
3	22B00001-001	Power Line Filter	
4	26-00003-001	Service Outlet	
5	24-00002-002	Fuse, 1.5 AMP, 3AG, Slo-Blo, 250V	
5A	24-00002-001	Fuse, 3AMP, 3 AG, Slo-Blo, 250V	
6	24-00001-001	Fuse Holder	171000
7	35-00001-001	Barrier Strip, 8 Position	100027
8	42-00034-001	Power Mounting Board	850071
9	29-00005-001	Switch, Interlock	024001
10	29-00004-001	Toggle Power Switch	021500
11	35B00002-001	Insulating Shield	199015
12	18A00001-001	Isolation Transformer	010002
13	998962	Noise Filter	AAT61017
14	998703	Shield Cover	
15	61-00030-001	Bracket Interlock Switch	



# SWITCHING REGULATOR & CABINET PARTS

FIGURE 3

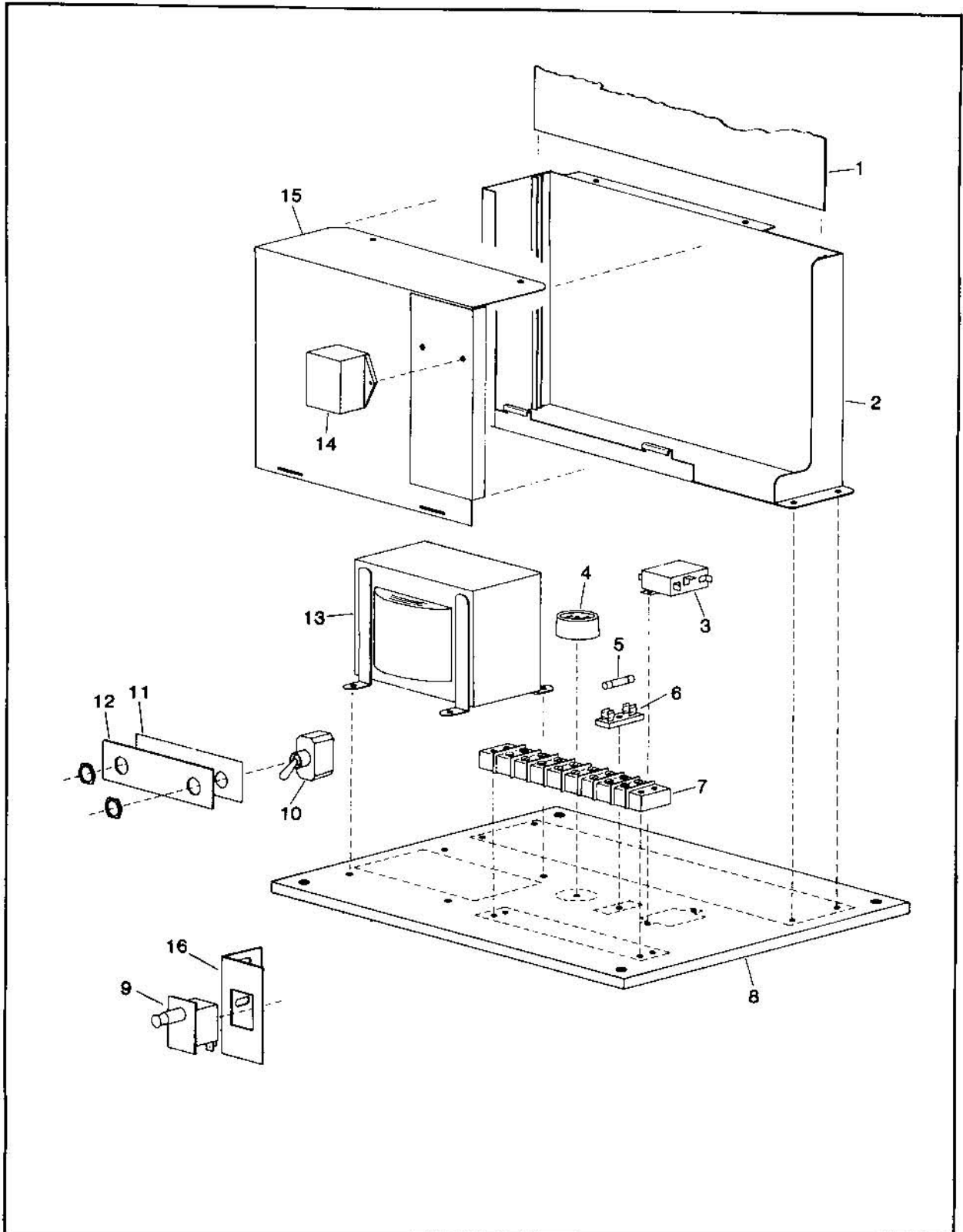

## CONTROL PANEL

FIGURE 4

ITEM	TAITO PART NO.	DESCRIPTION	REFERENCE
1	29-00011-001	Joystick Assembly 2-Way	850084
2	42D0058-001	Control Panel (Wood)	
3	61A00015-001	Strike Hook	390003
4	29-00009-001	Push Button Assembly (White)	BTK00004
5	47C00007-001	Dash Panel, Screened	

**CONTROL PANEL**

**FIGURE 4**

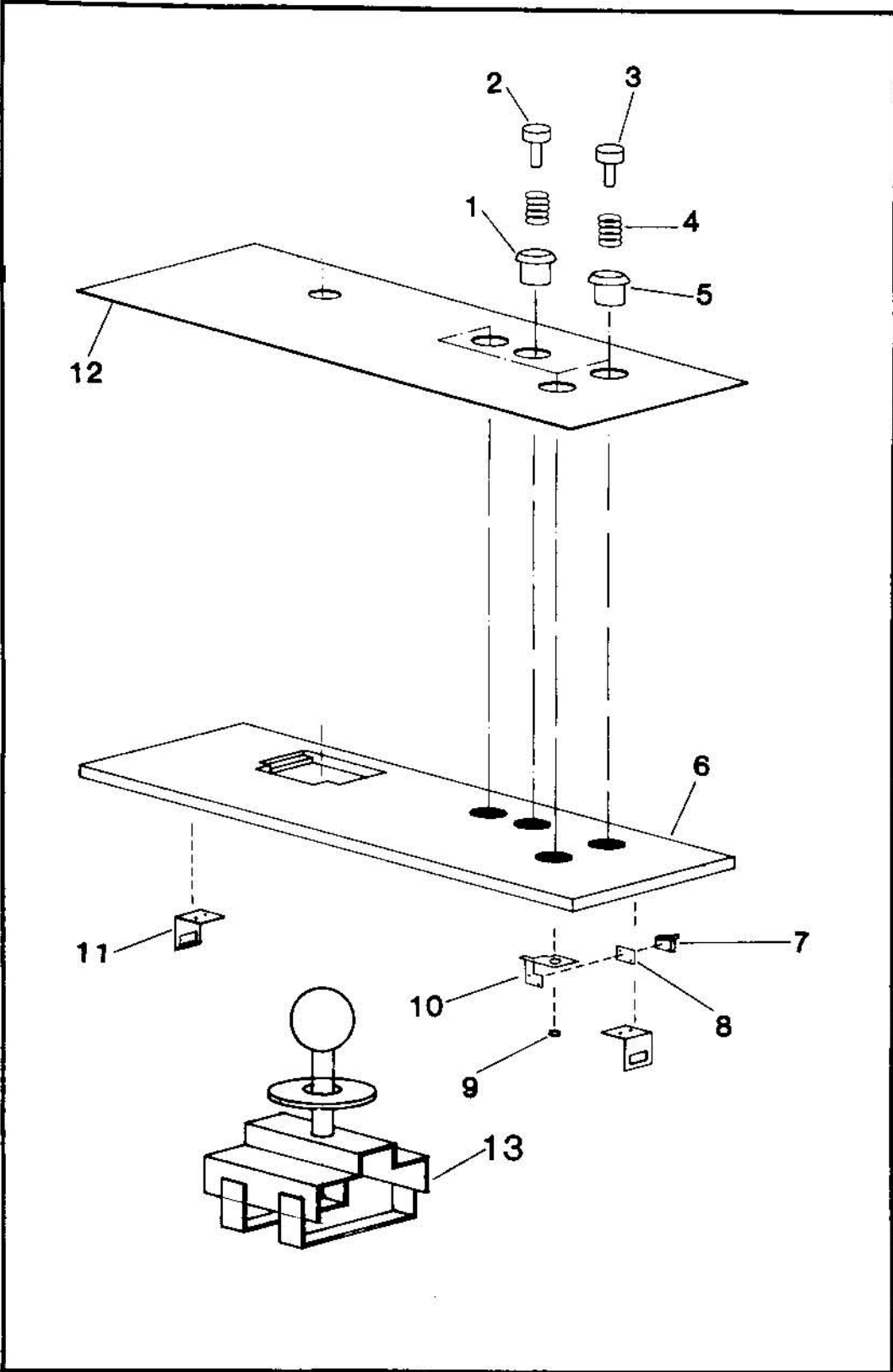

## MOUNTING CHASSIS ASSEMBLY

FIGURE 5

ITEM	TAITO PART NO.	DESCRIPTION	REFERENCE
1	85007	PC Board Guide "B"	WTO 90008
2	61800050-001	Stop Bracket	TUO 200010
3	500059	Shaft P C Chassis	TVO 20001
4	25-00015-001	44 Position Housing Connector	
5	500055	Plate Shield	CVO 300023
6		Overall Board Set	
	08-00004-001	Taito "ZARZON"™	
		or	
	08-00006-001	SNK "ZARZON"™	
7	850006	PC Board Guide "A"	AAO 19547

\* Item 6 may be 2 or 3 board set

**MOUNTING CHASSIS ASSEMBLY**

**FIGURE 5**

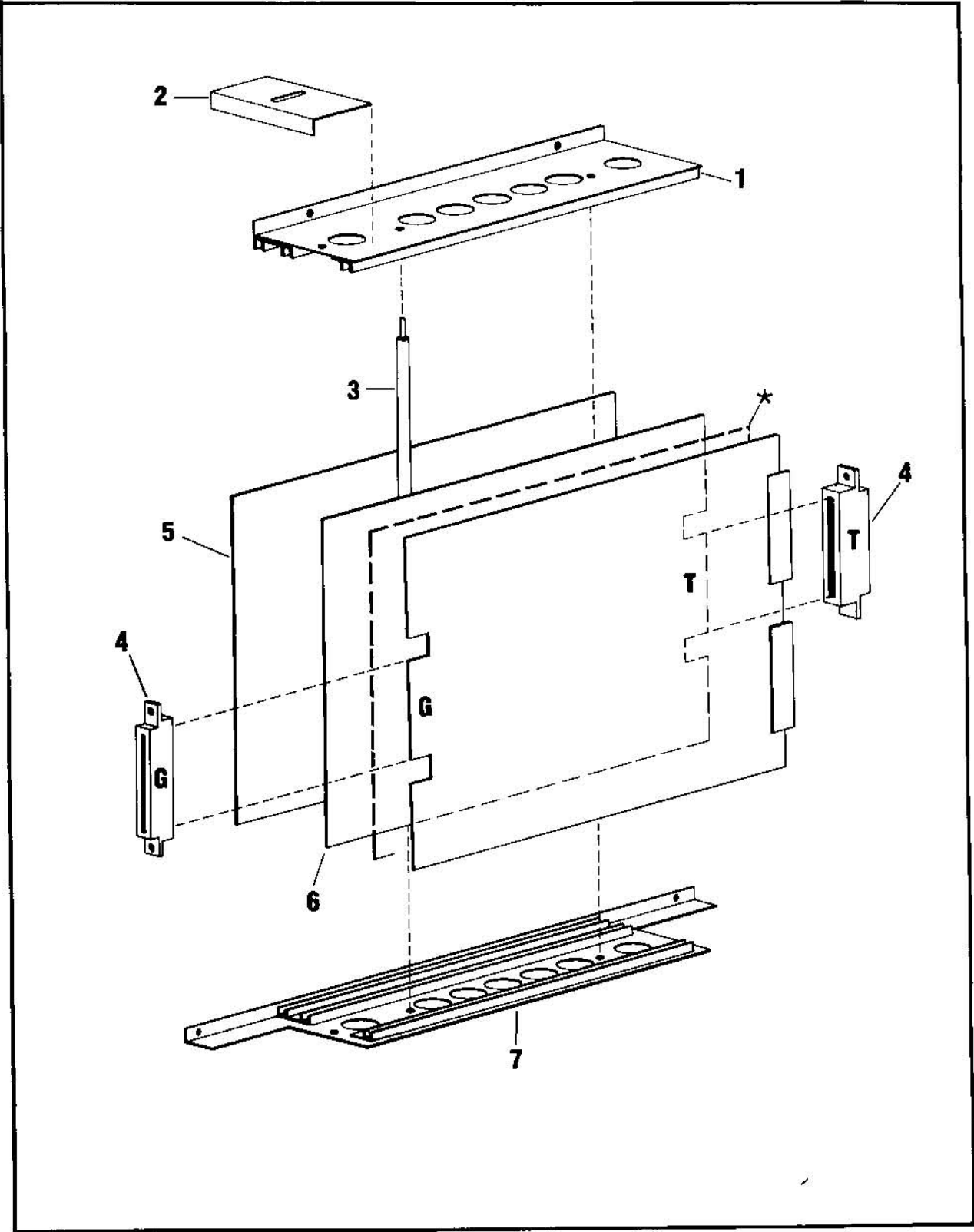

## C.P.U. BOARD "A"

FIGURE 6

ITEM	TAITO PART NO.	DESCRIPTION	REFERENCE
		ZARZON CUP PC BOARD "A"	
BS		PC Board Sticker (H000049)	
VR	11-60001-102	Variable Resistor 1K	
50P	99-AA055154	Angle Pin Header PS 50P	
IS1	99-055787	IC Socket 25P	
IS2	99-999552	IC Socket (Wire-Wrap Type) 14P (SNK Only)	
D1	99-AAT12025	Diode 1S1588	
TR	99-AAT11005	Transistor 2SC458	
X-TAL	99-AA069563	X-Tal 11.289MHZ	
OP	99-AAT31052	OP Amplifier MB3713	
IC1	99-AAT33001	LS IC 74LS00	
IC2	99-AAT33003	LS IC 74LS02	
IC3	99-AAT33005	LS IC 74LS04	
IC4	99-AAT33006	LS IC 74LS05	
IC5	99-AAT33011	LS IC 74LS10	
IC6	99-AAT33026	LS IC 74LS30	
IC7	99-AAT33051	LS IC 74LS74	
IC8	99-AAT33062	LS IC 74LS86	
IC9	99-AAT33067	LS IC 74LS93	
IC10	99-AAT33089	LS IC 74LS125	
IC11	99-AAT33096	LS IC 74LS138	
IC12	99-AAT33109	LS IC 74LS154	
IC13	99-AAT33118	LS IC 74LS163	
IC14	99-AAT33156	LS IC 74LS244	
IC15	99-AAT33170	LS IC 74LS273	
IC16	99-AAT33220	LS IC 74LS393	
IC17	99-AAT32141	Sound Generator IC SN76477	
IC18	99-AAT31028	TTI IC NE556	
IC19	99-AAT31028	TTI IC NE5563	
IC20	99-AAT31011	OP Amplifier LM3900	
IC21	99-AAT31036	OP Amplifier LM324	
IC22	99-AAT36007	C-MOS IC MC14006B	
IC23	99-AAT36067C	C-MOS IC MC14066B	
IC24	99-HT001145	Static Ram MK4118N 40	
CPU	99-AAT34010	CPU 6502	
ROM 1	16-00002-001	P-ROM 1FH 2716	
ROM 2	16-00002-002	P-ROM 2AFJ 2716	
ROM 3	99-997511	P-ROM SS-3 or 124 2716	
ROM 4	16-00002-004	P-ROM 4G 2716	
ROM 5	16-00002-005	P-ROM 5F 2716	
ROM 6	99-997512	P-ROM SS-6 or 124 2716	

ITEM	TAITO PART NO.	DESCRIPTION	REFERENCE
ROM 7	99-997512	P-ROM SS-7 or 128 2716	
ROM 8	99-997514	P-ROM SS-8 or 129 2716	
ROM 9	99-997515	P-ROM SS-9 or 130 2716	
ROM10	16-00002-010	P-ROM 10FG 2716	
ROM 11	99-997516	P-ROM SS-11 or 132 2716	
ROM 12	16-00002-012	P-ROM 12A 2716	
ROM 13	99-997517	P-ROM SS-13 or 134 2716	
C1	99-AAT41326	CAP. CERAMIC 22pf 50V	
C2	99-AAT41399	CAP. CERAMIC 22pf 50V	
C3	99-AAT41403	CAP. CERAMIC .0022mf 50V	
C4	99-AAT41403	CAP. CERAMIC .0047mf 50V	
C5	99-AAT41411	CAP. CERAMIC 0.01uf 50V	
C6	99-AAT41672	CAP. CERAMIC 0.1uf 50V	
C7	99-AAT41241	CAP. FILM .033mf, 50V	
C8	99-AAT41425	CAP. TANTALUM 1uf 25V	
C9	99-AAT41426	CAP. TANTALUM 22uf 25V	
C10	99-AAT41430	CAP. TANTALUM 10uf 25V	
C11	99-AAT41035	CAP. ELECTROLYTIC 25V 47uf	
C12	99-AAT41043	CAP. ELECTROLYTIC 35V100uf	
C13	99-AAT41040	CAP. ELECTROLYTIC 25V100uf	
R1	99-AAT51741	RES. CARBON 100ohm $\frac{1}{4}W \pm 5\%$	
R2	99-AAT51745	RES. CARBON 150ohm $\frac{1}{4}W \pm 5\%$	
R3	99-AAT51749	RES. CARBON 220ohm $\frac{1}{4}W \pm 5\%$	
R4	99-AAT51757	RES. CARBON 470ohm $\frac{1}{4} \pm 5\%$	
R5	99-AAT51759	RES. CARBON 560ohm $\frac{1}{4}W \pm 5\%$	
R6	99-AAT51765	RES. CARBON 1K $\frac{1}{4}W \pm 5\%$	
R7	99-AAT51771	RES. CARBON 1.8K $\frac{1}{4}W \pm 5\%$	
R8	99-AAT51773	RES. CARBON 2.2K $\pm 5\%$	
R9	99-AAT51781	RES. CARBON 4.7K $\frac{1}{4} \pm 5\%$	
R10	99-AAT51785	RES. CARBON 6.8K $\frac{1}{4} \pm 5\%$	
R11	99-AAT51789	RES. CARBON 10K $\frac{1}{4} \pm 5\%$	
R12	99-AAT51793	RES. CARBON 15K $\frac{1}{4} \pm 5\%$	
R13	99-AAT51795	RES. CARBON 18K $\frac{1}{4} \pm 5\%$	
R14	99-AAT51797	RES. CARBON 27K $\frac{1}{4} \pm 5\%$	
R15	99-AAT51799	RES. CARBON 27K $\frac{1}{4} \pm 5\%$	
R16	99-AAT51801	RES. CARBON 33K $\frac{1}{4} \pm 5\%$	
R17	99-AAT51805	RES. CARBON 47K $\frac{1}{4} \pm 5\%$	
R18	99-AAT51809	RES. CARBON 68K $\frac{1}{4} \pm 5\%$	
R19	99-AAT51813	RES. CARBON 100K $\frac{1}{4} \pm 5\%$	
R20	99-AAT51829	RES. CARBON 470K $\frac{1}{4} \pm 5\%$	



## CRT CONTROLLER BOARD "B"

FIGURE 7

ITEM	TAITO PART NO.	DESCRIPTION	REFERENCE
		ZARZON CPU PC BOARD "B"	
50P	99-AA055154	Angle Pin Header-50Pin	
DS	99-AA052566	Dip Switch DSS8	
IS1	99-AA044786	IC Socket 16P	
IS2	99-AA055103	IC Socket 18P	
IS3	99-AA055787	IC Socket 24P	
IS4	99-AA055812	IC Socket 40P	
IC1	99-AAT33001	LS IC 74LS00	
IC2	99-AAT33003	LS IC 74LS02	
IC3	99-AAT33005	LS IC 74LS04	
IC4	99-AAT33009	LS IC 74LS08	
IC5	99-AAT33011	LS IC 74LS10	
IC6	99-AAT33027	LS IC 74LS32	
IC7	99-AAT33051	LS IC 74LS74	
IC8	99-AAT33062	LS IC 74LS86	
IC9	99-AAT32020	TTL IC 74121	
IC10	99-AAT33089	LS IC 74LS125	
IC11	99-AAT33110	LS IC 74LS155	
IC12	99-AAT33112	LS IC 74LS157	
IC13	99-AAT33118	LS IC 74LS163	
IC14	99-AAT33121	LS IC 74LS166	
IC15	99-AAT33127	LS IC 74LS174	

ITEM	TAITO PART NO.	DESCRIPTION	REFERENCE
IC16	99-AAT33152	LS IC 74LS240	
IC17	99-AAT33156	LS IC 74LS156	
IC18	99-AAT33170	LS IC 74LS273	
IC19	99-AAT33176	LS IC 74LS283	
IC20	99-AAT32163	Static Ram PD2114LC	
IC21	99-AAT34105	CRT CONTROLLER IC HD46505SP	
ROM1	99-997518	P-ROM 2716 D or 135	
ROM2	99-997519	P-ROM 2716 U or 136	
ROM3	99-997478	BIPOLAR ROM IM5610 (OR138)	
C1	99-AAT41326	Cap Ceramic .220pf 50V	
C2	99-AAT41399	Cap Ceramic 100pf, 50V	
C3	99-AT41672	Cap Ceramic 0.1uf 50V	
R1	99-AAT51741	Res, Carbon 100 ohm 1/4 ±5%	
R2	99-AAT51749	Res, Carbon 220 ohm 1/4 ±5%	
R3	99-AAT51757	Res, Carbon 470 ohm 1/4 ±5%	
R4	99-AAT51765	Res, Carbon 1K 1/4 ±5%	
R5	99-AAT51781	Res, Carbon 47K 1/4 ±5%	
R6	99-AAT51797	Res, Carbon 22K 1/4 ±5%	
RB	99-AAT55058	Resistor Block 2.2 ohmx8	





# OPTION SWITCH & VOLUME CONTROL LOCATIONS

FIGURE 8

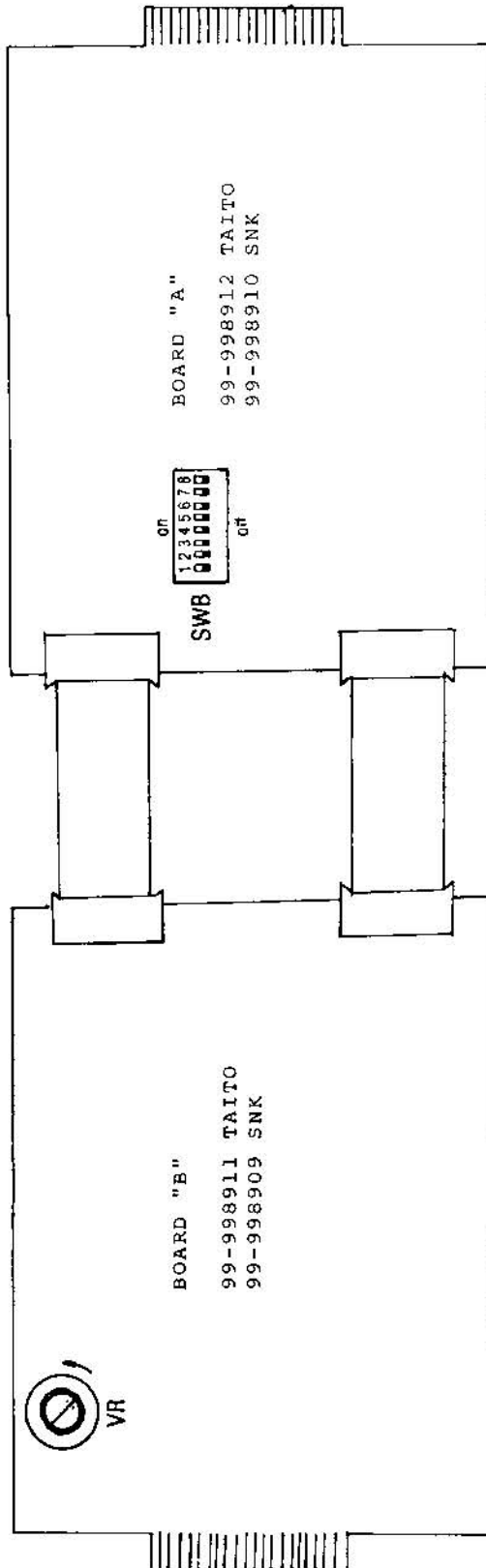



SCHEMATIC CPU BOARD A  
1 OF 3

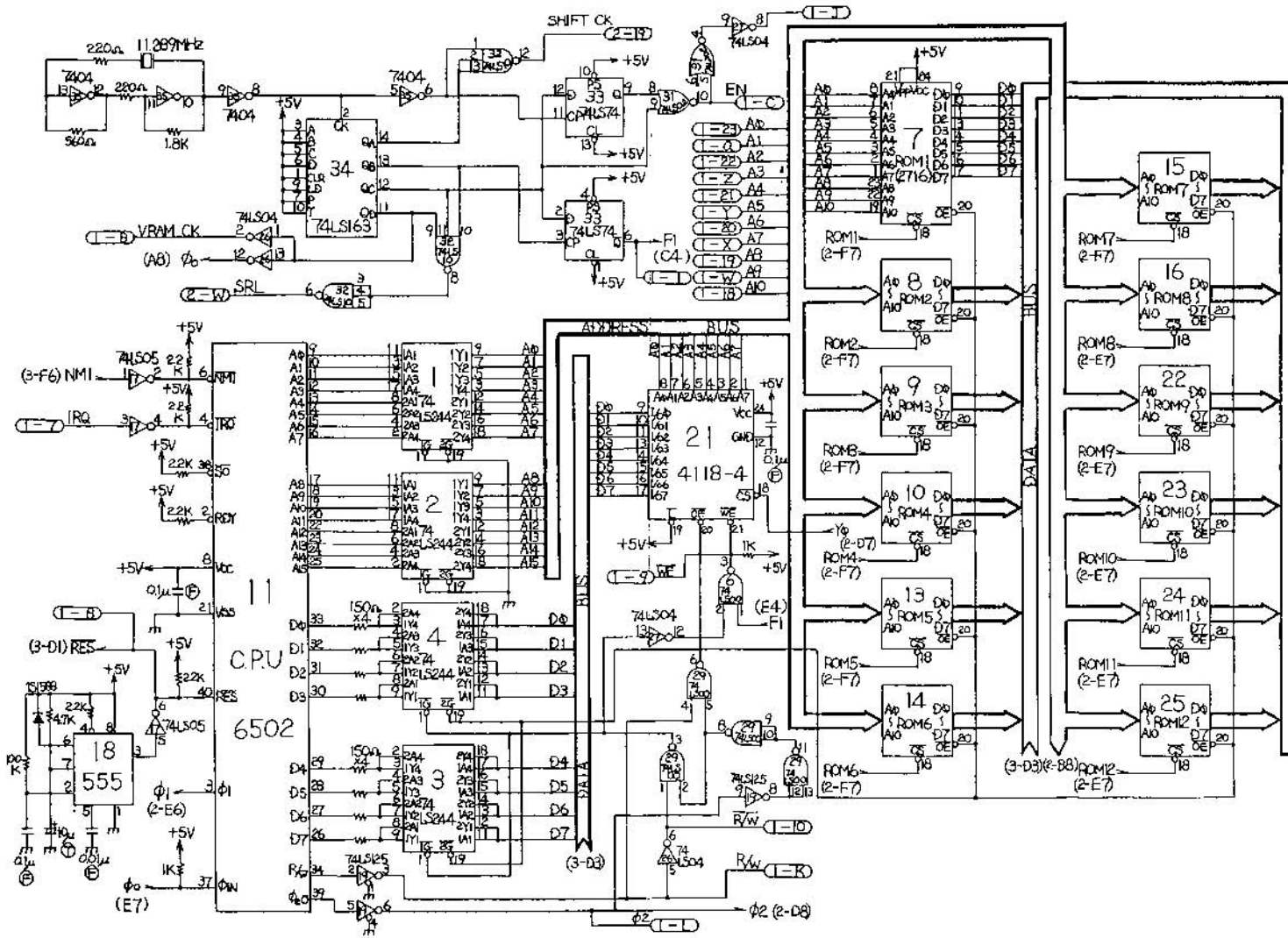





**SCHEMATIC CRT BOARD "B"**  
2 OF 3

