

SAMMIE

~the Amazing Jumpin' Dog~

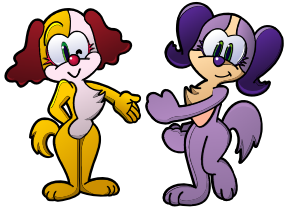

OPERATING MANUAL

Sammy USA Corporation

901 Cambridge Drive
Elk Grove Village, IL 60007-2434
Phone: (847) 364-9787
FAX: (847) 364-9831
Toll fee: 1-888-US-SAMMY
Internet: www.sammyusa.com

TABLE OF CONTENTS

SPECIFICATIONS	Page 2
HANDLING AND INSTALLATION	Page 3
HOW TO PLAY	Page 4
CAROUSEL UNITS	Page 5
HOW TO ADJUST THE PRIZE CAROUSEL UNITS FOR YOUR PRIZES	
PRIZES	Page 6-8
PRIZE SIZES	
SIZE OF KEY CHAIN & LOOP	
HOW TO FILL THE PRIZES (PRIZE FILLING MODE)	
PRIZE PAYOUT CHECK MODE	
HOW TO CLEAR PAYOUT DATA (DEFAULT)	
GAME SETTING MODE	Page 9,10
HOW TO ENTER THE GAME SETTING MODE	
HOW TO ADJUST THE GAME SETTING STYLE	
IF YOU HIT THE CLEAR SWITCH DURING THE GAME SETTING MODE....	
SETTING FUNCTIONS	
TABLE OF SETTING FUNCTIONS	Page 11-13
TEST MODE	Page 14
HOW TO ENTER THE TEST MODE	
HOW TO GO BACK TO THE REGULAR GAME MODE	
ERRORS	Page 15
TILT	
COIN ERROR	
PRIZE VENDING ERROR	
CUSTOM MARQUEE SET-UP & PARTS NUMBER	Page 16
OPTION (BULK HOOPER ASSY, DBA, SECURITY BAR KIT)	Page 17, 18

SPECIFICATIONS

POWER 120VAC @ 60Hz USA & CANADA
230VAC @ 50Hz EUROPE

DIMENSIONS Width: 39" (990mm)
Height: 76 1/2" (1675 mm)
Depth: 27" (675mm)

WEIGHT 310 lb (140 kg)

Manual, SAMMIE
Part #: 51-30-321

BULK HOPPER

Holds 1", 2", 3" and 4" capsule.
Default is 2" capsule.
(Modification change necessary
for capsule size change)



SPECIFICATIONS (CONT.)

LIMITED WARRANTY

Sammy USA Corp. warrants all products to be free from defective materials and workmanship for a period of thirty (30) days from the Sammy USA Corp. invoice date unless otherwise specified in writing by Sammy USA Corp. The extent of this warranty applies to all electronic assemblies only, and does not include lamps and fuses.

This limited warranty is invalid for any product that upon examination is deemed to have been subject to misuse, improper repair or installation, neglect or violation of specifications or other instructions published by Sammy USA Corp. There are no additional warranties described above. The limited warranties described above shall be in lieu of any other warranty, expressed or implied, including but not limited to any implied warranty of merchantability or fitness for a particular purpose.

HANDLING AND INSTALLATION

PLEASE TAKE A MOMENT TO READ THE FOLLOWING BEFORE YOU TURN ON YOUR NEW GAME.

The **SAMMIE the amazing jumping dog** prize redemption game is an indoor game machine. It is not designed for outdoor use. Avoid installing the game in the following locations:

- ▶ Locations subject to rain or water damage
- ▶ Locations in direct sunlight
- ▶ Locations subject to extreme heat
- ▶ Locations near hazardous or flammable liquids or chemicals

You will need the following dimensions of space for your machine to be properly installed into your location:

- ▶ 85 inches height
- ▶ 45 inches in width

INSTALLATION

- ▶ Unpack your game carefully. Be careful of the shipping staples. They can be sharp.
- ▶ Your game is assembled and will not need any assembly.
- ▶ Level your game using enclosed Leg levelers. Prizes will then fall properly.
- ▶ The standard voltage for U.S. and Canada 120V / 125V - 3A; Europe 220V / 240V - 2A.
- ▶ Use of extension cords is prohibited.
- ▶ Use only a grounded outlet. **YOUR GAME MUST BE GROUNDED!!!**
- ▶ The minimum space required for operation in your locations should be:
 - ▶ 85" high
 - ▶ 45" wide
 - ▶ 60" depth

THE GAME MUST BE LEVEL. IF THE GAME IS NOT ON A LEVEL SURFACE, THE TILT SYSTEM WILL MALFUNCTION. USE A LEVEL TO AVOID NEEDLESS ADJUSTMENTS.

SAFETY PRECAUTIONS

- ▶ Be sure to turn the power off or unplug the game before working on the unit.
- ▶ Do not unplug game by pulling on the line cord.
- ▶ Replace line cord if the insulation is damaged in any way with one of equal quality.
- ▶ Replace open fuses with same type and rating.
- ▶ Re-check and re-seat all harness connections.

HOW TO PLAY

- ▶ Insert coin (s).
- ▶ Select one button A thru F to select the prize you hope to win! (Score display shows number of jump that you must skip to win prize.)
- ▶ Make SAMMIE skip rope 30 times to win a prize!
- ▶ Only one jump for each turn of rope.
- ▶ If you have BULK version, Mercy capsule will be paid out when you lose. (operator adjustable)

HOW TO PLAY

- ① Insert coin(s). Select one button **A** thru **F** to choose the prize you want to win!
- ② Press the "JUMP" button to START the GAME!

Make **SAMMIE** skip **30 times** to win a prize!
Only one jump for each turn of the rope.

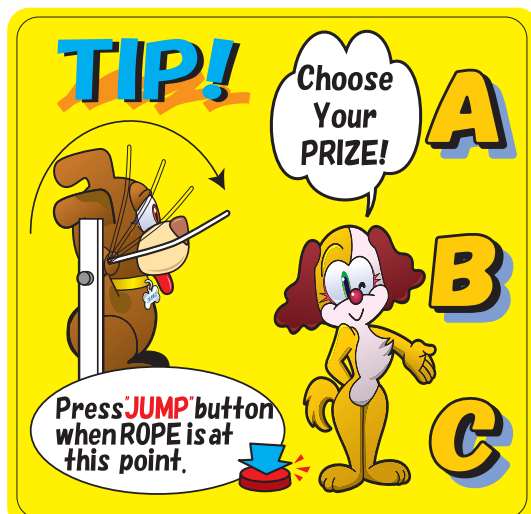

CAROUSEL UNITS



HOW TO ADJUST THE CAROUSEL UNITS FOR YOUR PRIZES

You can adjust each Carousel Unit level for your prize size.

- 1 Take off 2 screws from the Carousel Unit Cover.
- 2 Take off 2 screws from the Carousel Unit Frame.
- 3 Adjust the Carousel Unit Frame onto one of 3 levels for your prizes.

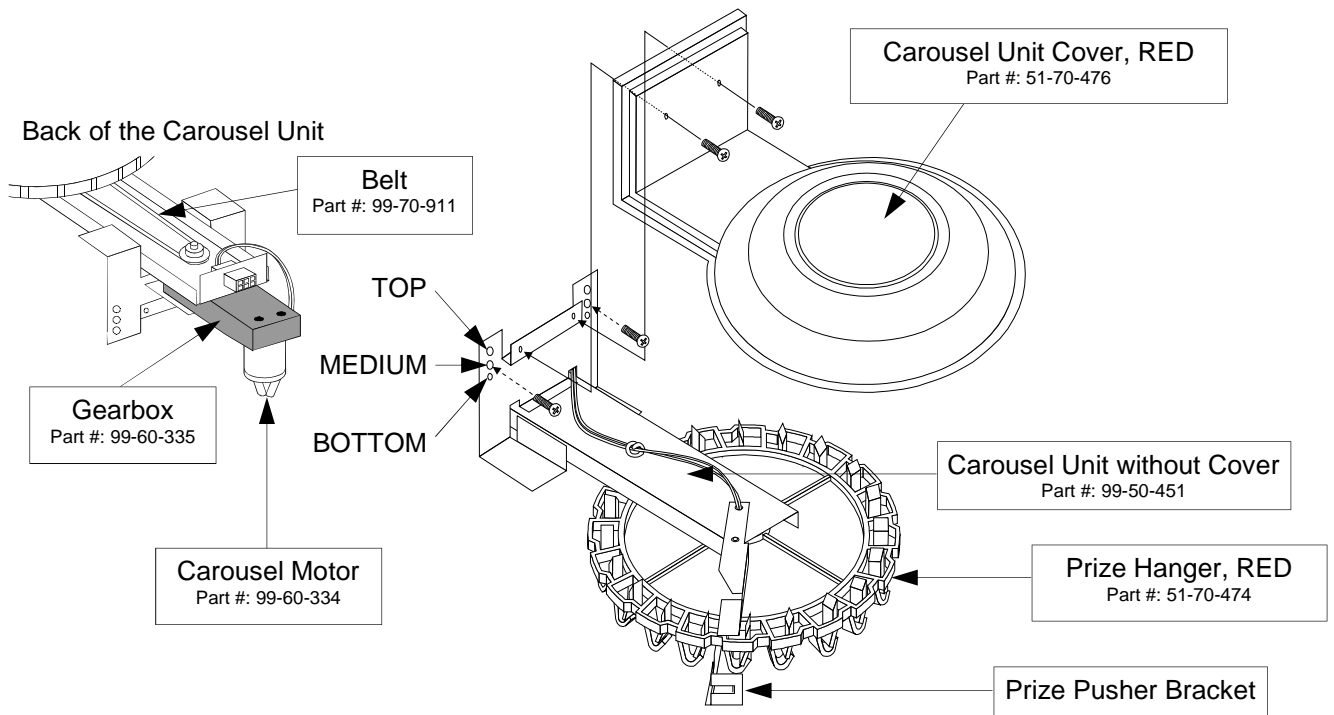

PRIZES

IF YOU DO NOT USE PRIZES OF THE FOLLOWING RECOMMENDED SIZES, THE MACHINE MAY MALFUNCTION AND YOU MAY GET UNEXPECTED RESULTS.

PRIZE SIZES

MAXIMUM Height: 6" (150 mm) *Including Key Chain and Loop
Weight: 2.6 oz (75 g)



If bottom of the prize touches the next Carousel Unit Cover, adjust the Vending Units.
(See page 5, HOW TO ADJUST THE CAROUSEL UNITS FOR YOUR PRIZES)

SIZE OF KEY CHAIN & LOOP

MINIMUM Height: 1" (25.5 mm)
MAXIMUM Width: 1 3/4" (44.5 mm)

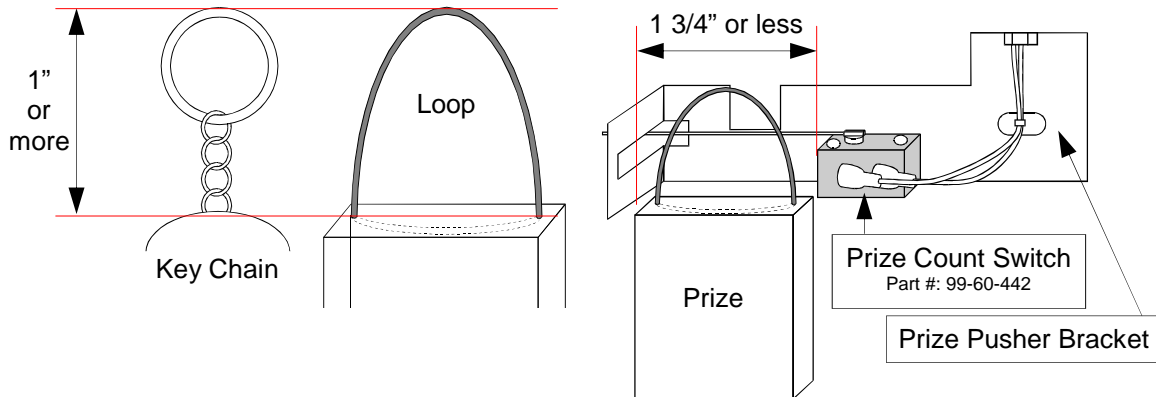

CLOSE THE KEY RING BEFORE FILLING!

When you fill a prize which has this type of Key Ring, you must close the Key Ring before Filling. If the Key Ring is not closed, the machine will malfunction.

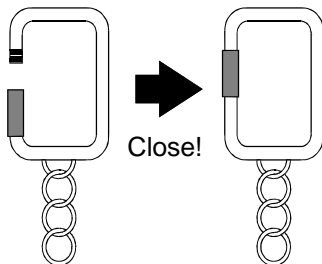

HOW TO FILL THE PRIZES (PRIZE FILLING MODE)

Press hold JUMP button then press METER switch to enter PRIZE FILL MODE. 7 seg. Display on Control Panel shows "Pr".

Press and hold the PRIZE SELECT button to turn the Prize Hangers and fill prizes.

Fill prizes on 4 or 5 Prize Hangers from left side of the Prize Pusher Bracket and advance 4 or 5 Prize Hangers for next filling.

Press other PRIZE SELECT button on the Control Panel to fill the prizes on next Carousel Unit. Press RESET switch to return to game mode.

View of Control Panel

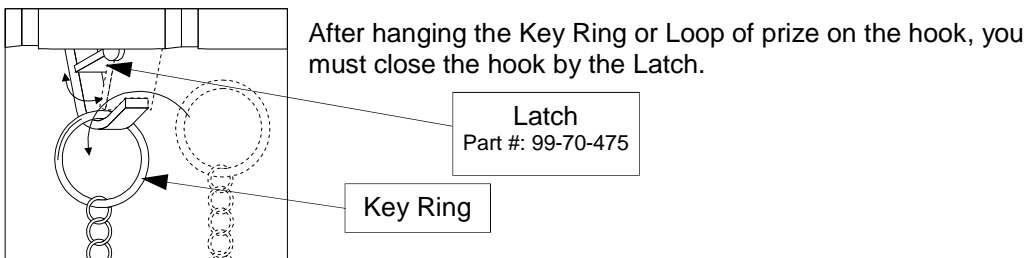
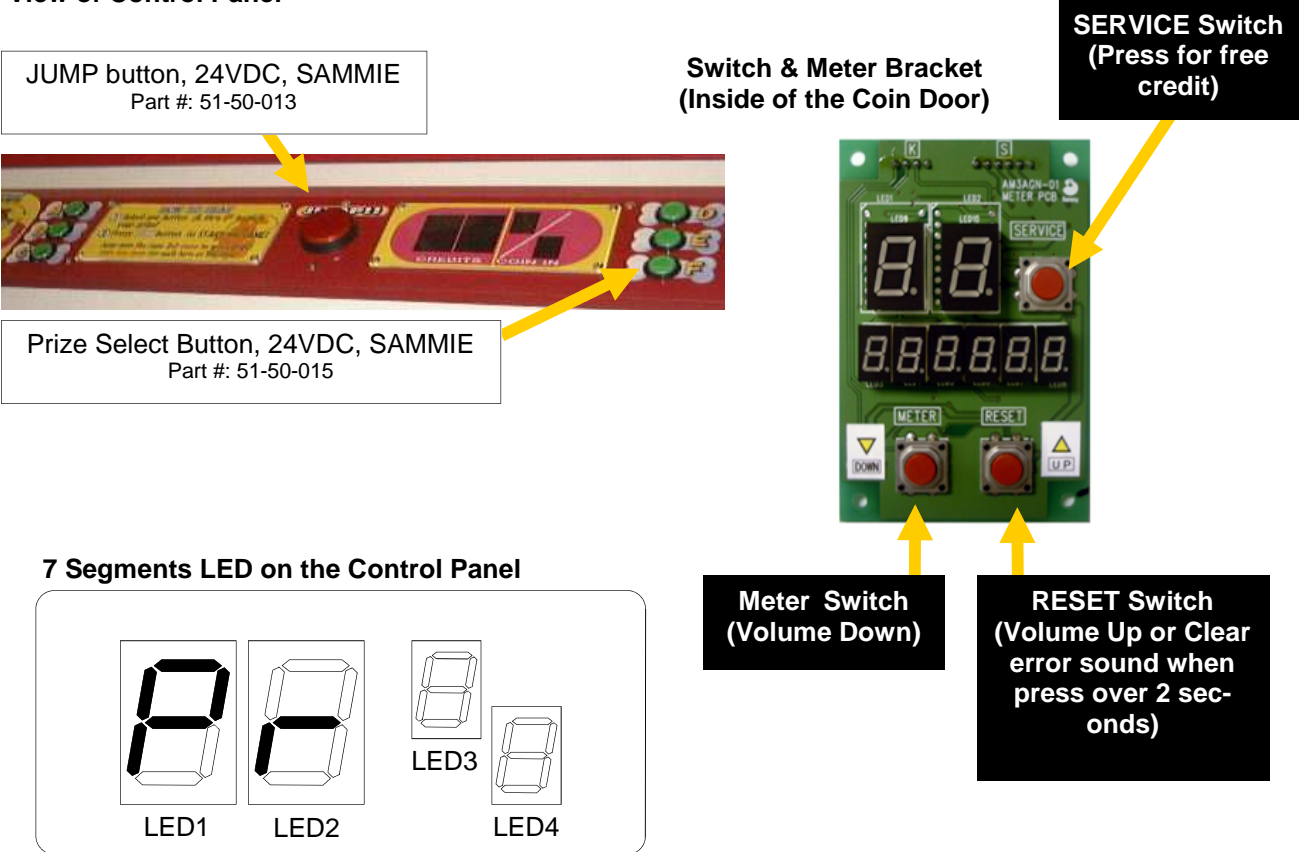

DO NOT FILL THE PRIZES FROM RIGHT SIDE OF THE PRIZE PUSHER BRACKET!
If you fill the prizes from right side of the Prize Pusher Bracket, the prizes will drop when you advance the Prize Hanger.

CAROUSEL PAYOUT CHECK MODE

Press the SERVICE and METER switches, at the same time, hold for 2 seconds to enter the CAROUSEL PAYOUT CHECK mode.

Press METER switch to select Carousel Unit number that you need to know how many prizes are paid out from each Carousel. 2 digit display shows r1, r2, r3 and L1, L2, L3. And 6 digit display shows QTY of Prize paid out from each Carousel Unit.

Press and hold RESET switch over 2 seconds to return to normal game mode.

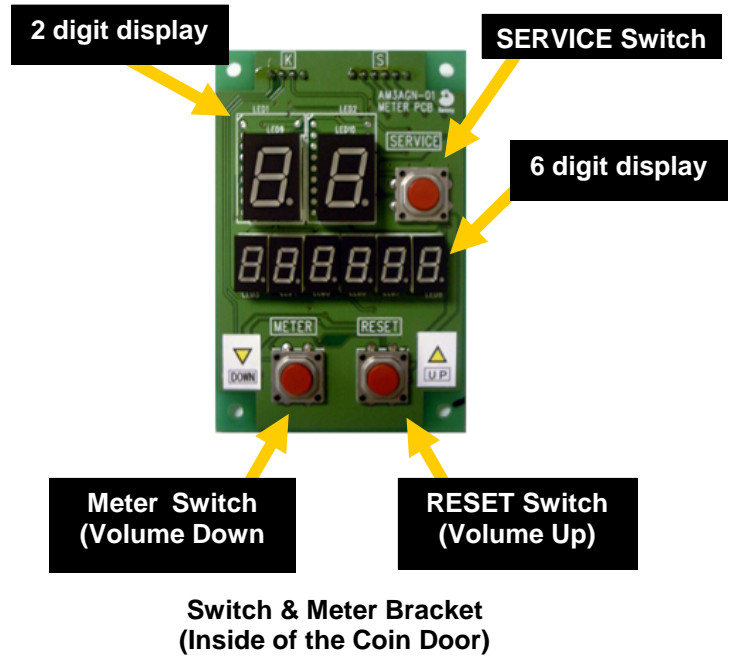

HOW TO CLEAR PAYOUT DATA (DEFAULT)

Press and hold JUMP button then press METER and RESET switches over 2 sec. to reset all payout data for each carousel unit to ZERO.

GAME SETTING MODE

You can adjust each game setting in this mode.

HOW TO ENTER THE GAME SETTING MODE

Press and hold the Service Switch about 2 seconds to enter the GAME SETTING MODE. LED1 & LED2 on the Control Panel shows FUNCTION # and LED3 & LED4 on the Control Panel shows SETTING #. (See page 11 to 12 TABLE OF SETTING FUNCTIONS)

Switch & Meter Bracket (Inside of the Coin Door)

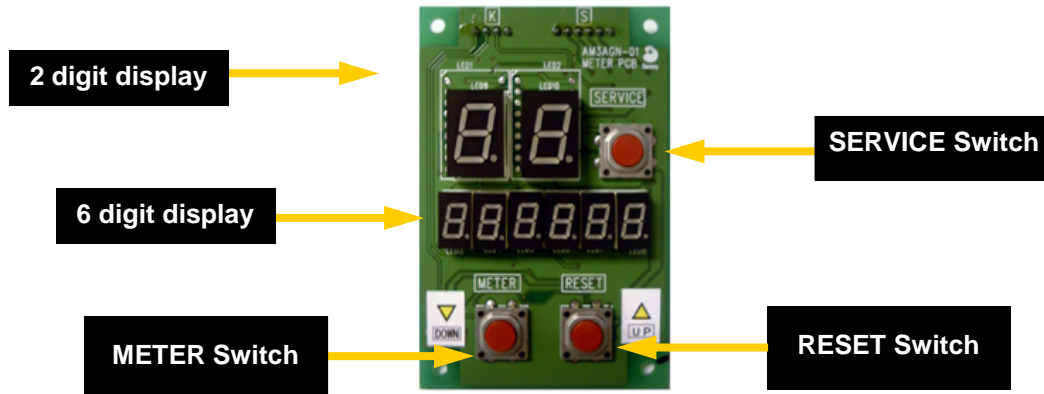

7 Segments LED on the Control Panel

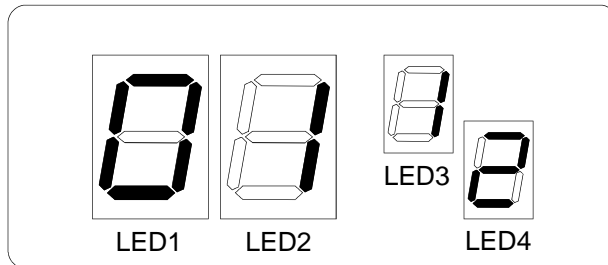

HOW TO ADJUST THE GAME SETTING

- 1 Advance the FUNCTION # by hitting the Service Switch.
- 2 Change the SETTING # by hitting the METER and RESET switches.
- 3 After you change setting, hit the Service Switch to advance the functions. After Function number R3, press SERVICE switch again to return to the regular game mode. Then the adjustment will be done.

DEFAULT SETTING

If you want to clear all credits or change all setting to Factory default, press hold JUMP button then hold RESET switch over 2 seconds.

SETTING FUNCTIONS

The contents of each function follow the TABLE OF SETTING FUNCTIONS.

01 WINABILITY

You can adjust the level of WINABILITY (difficulty) in this function.
When you adjust on SETTING #20, player will be able to win every play.
(See page 11)

02 COIN CHUTE

You can adjust value of the COIN CHUTE in this function.

03 HOW MANY JUMPS TO WIN

You can adjust number of JUMPS for WIN in this function.

04 PRIZE EMPTY ON CAROUSEL

This function will allow you to adjust how the machine will respond, in case someone wins on a carousel that has no prizes.

05 MERCY CAPSULE PAYOUT

This function will allow you to adjust Bulk Hopper Payout Setting.

06 TILT SYSTEM

You can set TILT SYSTEM on or off in this function.
If you choose SETTING #0 (ON), the machine will make noise for about 15 seconds when the machine is shaken.

07 ATTRACT SOUND

You can set ATTRACT SOUND on or off in this function.

08 FREE PLAY

You can set FREE PLAY on or off in this function.

09 BONUS CREDIT

Use these settings for operator who has a bill acceptor on the machine.
NOTE: Bill acceptor is optional.

L1 THROUGH r3 PRIZE VALUE OF EACH CAROUSEL UNIT

An important feature of SAMMIE the Amazing Jumping Dog is the ability to change the value on each individual Carousel unit based on the prize's value (cost). In other words, the prizes can vary \$0.50 up to \$50.00 for each individual Carousel unit. (The current factory setting is for \$1.75 value on every Carousel unit in the game.) It is very important that you set the Carousel units properly according to the TABLE OF SETTING FUNCTIONS. By doing this properly the game will be able to adjust the difficulty for winning prizes of various values. If not done properly, it could result in unexpected vending. If you do not understand this section, please contact our service department for further details.

TABLE OF SETTING FUNCTIONS (SAMMIE Jumping Dog)

FUNCTION# (LED1 & 2)	FUNCTION	SETTING# (LED3 & 4)	SETTING	NOTE			
01	WINABILITY	01	HARDEST ↑				
		02					
		03					
		04					
		05					
		06					
		07					
		08					
		09					
		10					
					11	NORMAL	
					12	↓ EASIEST	
		13					
		14					
		15					
		16					
		17					
		18					
		19					
		20					
		20	WINNER EVERY PLAY				
02	COIN CHUTE	01	1 COIN / 1 CREDIT	\$0.25 per play			
		02	2 COINS / 1 CREDIT	\$0.50 per play			
		03	3 COINS / 1 CREDIT	\$0.75 per play			
		04	4 COINS / 1 CREDIT	\$1.00 per play			
		05	5 COINS / 1 CREDIT	\$1.25 per play			
		06	6 COINS / 1 CREDIT	\$1.50 per play			
		07	7 COINS / 1 CREDIT	\$1.75 per play			
		08	8 COINS / 1 CREDIT	\$2.00 per play			
		09	9 COINS / 1 CREDIT	\$2.25 per play			
		10	10 COINS / 1 CREDIT	\$2.50 per play			
		11	11 COINS / 1 CREDIT	\$2.75 per play			
		12	12 COINS / 1 CREDIT	\$3.00 per play			
		13	13 COINS / 1 CREDIT	\$3.25 per play			
		14	14 COINS / 1 CREDIT	\$3.50 per play			
		15	15 COINS / 1 CREDIT	\$3.75 per play			
		16	16 COINS / 1 CREDIT	\$4.00 per play			
		17	17 COINS / 1 CREDIT	\$4.25 per play			
		18	18 COINS / 1 CREDIT	\$4.50 per play			
		19	19 COINS / 1 CREDIT	\$4.75 per play			
		20	20 COINS / 1 CREDIT	\$5.00 per play			
03	HOW MANY JUMPS TO WIN	01	20 JUMPS				
		02	25 JUMPS				
		03	30 JUMPS				
		04	35 JUMPS				

"FACTORY INSTALLED" SETTING

FUNCTION# (LED 1 & 2)	FUNCTION	SETTING# (LED 3 & 4)	SETTING	NOTE
04	PRIZE EMPTY ON CAROUSEL	01	Replay.	
		02	Stop at error code.	
		03	Payout from next Carousel.	
05	MERCY CAPSULE PAYOUT	01	WHEN LOOSE	
		02	5 JUMPS	
		03	10 JUMPS	
		04	15 JUMPS	
		05	20 JUMPS	
		06	25 JUMPS	
		07	30 JUMPS	
		08	NO PAYOUT	
06	TILT SYSTEM	01	ON	
		02	OFF	
07	ATTRACT SOUND	01	ON	
		02	OFF	
08	FREE PLAY	01	OFF	Regular Game
		02	ON	Free play
09	BONUS CREDIT	01	OFF	
		02	4 COINS / 3 CREDITS	\$1.00/3 CREDITS
		03	20 COINS / 11 CREDITS	\$5.00/11 CREDITS

"FACTORY INSTALLED" SETTING

FUNCTION# (LED 1 & 2)	FUNCTION	SETTING# (LED 3 & 4)	SETTING	NOTE
L1, L2, L3 and R1, R2, R3	PRIZE VALUE OF EACH CAROUSEL UNIT	01	\$0.50	Use these settings when using prizes of various values. You can set each individual Carousel unit based on the prize cost. (See manual for detail.)
		02	\$0.75	
		03	\$1.00	
		04	\$1.25	
		05	\$1.50	
		06	\$1.75	
		07	\$2.00	
		08	\$2.25	
		09	\$2.50	
		10	\$2.75	
		11	\$3.00	
		12	\$3.25	
		13	\$3.50	
		14	\$3.75	
		15	\$4.00	
		16	\$4.25	
		17	\$4.50	
		18	\$4.75	
		19	\$5.00	
		20	\$6.00	
		21	\$7.00	
		22	\$8.00	
		23	\$9.00	
		24	\$10.00	
		25	\$12.50	
		26	\$15.00	
		27	\$17.50	
		28	\$20.00	
		29	\$25.00	
		30	\$30.00	
		31	\$35.00	
		32	\$40.00	
		33	\$45.00	
		34	\$50.00	

"FACTORY INSTALLED" SETTING

TEST MODE

You can check 6 tests in this mode.

HOW TO ENTER THE TEST MODE

Press hold SERVICE, METER and RESET switches over 3 seconds to to enter to TEST MODE. Press SERVICE switch to advance each test contents. Refer below.

01: OUTPUT TEST

Checks All lamps and LED Digits automatically.

02: INPUT TEST (INCLUDE COUNTER METER TEST)

Display 2 digit numbers on SCORE Display as below when following switches are activated. 2 digit Display shows "- -" when no switch activated.

Coin in and Prize out counter meters will count up when Prize select switch E and F are pressed.

Name of switch	Display	Name of switch	Display	Name of switch	Display	Name of switch	Display
Coin switch 1	C1	Prize select switch A	P1	Prize count switch A	U1	Rope loop sensor	H1
Coin switch 2	C2	Prize select switch B	P2	Prize count switch B	U2	Capsule count switch	A1
SERVICE switch	S1	Prize select switch C	P3	Prize count switch C	U3		
METER switch	S2	Prize select switch D	P4	Prize count switch D	U4		
RESET switch	S3	Prize select switch E	P5	Prize count switch E	U5		
JUMP switch	J1	Prize select switch F	P6	Prize count switch F	U6		

03: DOG TEST

Automatically DOG jumps & Misses the Rope by 5 different speeds. SCORE Display will display the number of jumps.

04: SOUND TEST

Press JUMP button to out put all sounds in Sound Memory card. SCORE Display will display the number of sound.

HOW TO GO BACK TO THE REGULAR GAME MODE

After SOUND TEST, press SERVICE switch once to go back to the REGULAR GAME MODE. Or just re-power on the game.

ERRORS

TILT

If you set 06 TILT SYSTEM "ON" in setting mode, the game will make noise and LED1 & 2 on the Control Panel will show "EL" when the machine is shaken. The error will automatically clear about 15 seconds later.

7 Segments LED on the Control panel

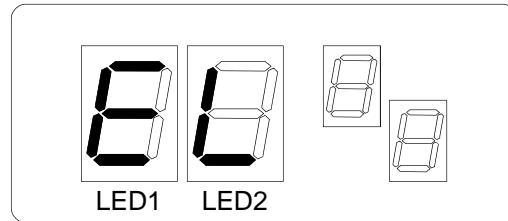

COIN ERROR

The game will make noise and LED1 & 2 on the Control Panel will show "EC" when the machine gets a coin jam. Check around the Coin Switch. Hit the RESET Switch inside of the Coin Door and clear the error.

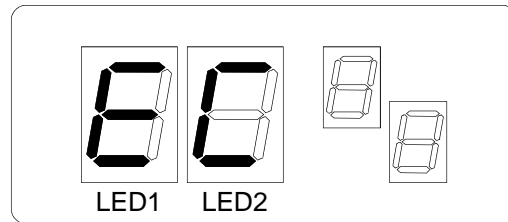

CAROUSEL UNIT ERROR

IF YOU SET 04 PRIZE EMPTY ON CAROUSEL "REPLAY"....

Game will make noise and LED1 & 2 on the Control Panel will show the Carousel Unit Number (r1, r2, r3 & L1, L2, L3) when player stops the lamp on an empty carousel unit (with no prizes). The error will automatically clear a few seconds later then machine re-start game.

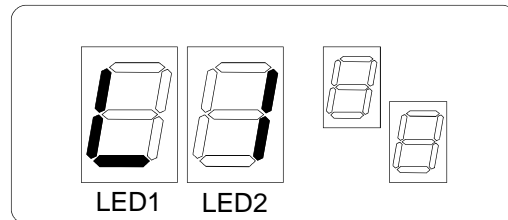

IF YOU SET 04 PRIZE EMPTY ON CAROUSEL "Stop at error code"....

Game will make noise and LED1 & 2 on the Control Panel will show the Carousel Unit Number when player stops the lamp on an empty carousel unit (with no prizes). Error code stay on display until power is turned off.

IF YOU SET 04 PRIZE EMPTY ON CAROUSEL "Payout from next carousel"....

Game will make noise and LED1 & 2 on the Control Panel will show the Carousel Unit Number when player stops the lamp on an empty carousel unit (with no prizes). The error will automatically clear a few seconds later then machine will payout prize from next carousel unit.

BULK HOPPER UNIT ERROR

IF YOU SET 05 MERCY CAPSULE PAYOUT "01 to 07 (Payout when loose or reach some score)"....

Game will make noise and LED1 & 2 on the Control Panel will show "CP" when no Capsule payout because the Hopper is empty or capsule is jammed. The error will automatically clear a few seconds later then machine re-start game.

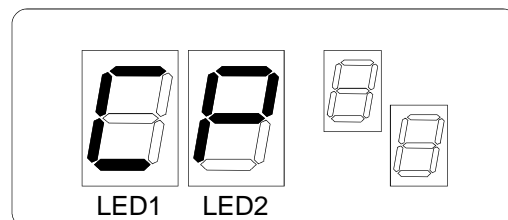

CUCUSTOM MARQUEE SET-UP & PARTS NUMBER

You can put your original marquee on your SAMMIE the amazing jumping dog for your location.

- 1 Use front door Key to open Front Door.
- 2 Remove original marquee out from Metal Glass Door top.
- 3 Put your original marquee as same spot as original mounted.



PART NUMBERS

Main CPU Board, SAMMIE, AM3AGK-01	51-10-001	Stepping Motor for Rope, SAMMIE	51-60-339
Score PCB, SAMMIE, AM3AGM-01	51-20-015	Solenoid Coil for jump, SAMMIE	51-60-901
Panel PCB, SAMMIE, AM3AGL-01	51-20-010	Rope Loop Sensor, K11300	51-60-560
Marquee, SAMMIE	51-30-130	Meter PCB, SAMMIE, AM3AGN-01	51-20-215
Decal Set (Bone A to F, payout...etc) SAMMIE	51-30-224	Power Supply ASSY, 5, 12 and 24VDC	99-60-112
Coin / Credit Sheet, SAMMIE	51-30-251	JUMP button, 24VDC, SAMMIE	51-50-013
Instruction sheet, SAMMIE	51-30-250	Motor PCB for Rope, SAMMIE, AM3AFW-02	51-20-175
Marquee Plexi, Clear, Mini SA	51-30-500	Prize Select button, 24VDC, SAMMIE	51-50-015
Carousel Unit without Cover	51-50-451	Motor, Prize Vending, DC12V, 47C-VG-500-C249	99-60-334
Control panel decal, Left & Right	51-30-210	Motor PCB for Bulk Hopper	51-20-178
Side decal, SAMMIE	51-30-200	Motor, Bulk Hopper	51-60-300
		Capsule motor Sensor, Bulk Hopper	51-60-550
		Capsule count switch, Bulk Hopper	51-60-447

PART NUMBERS

DOG Mech. Assy (Inside front view)

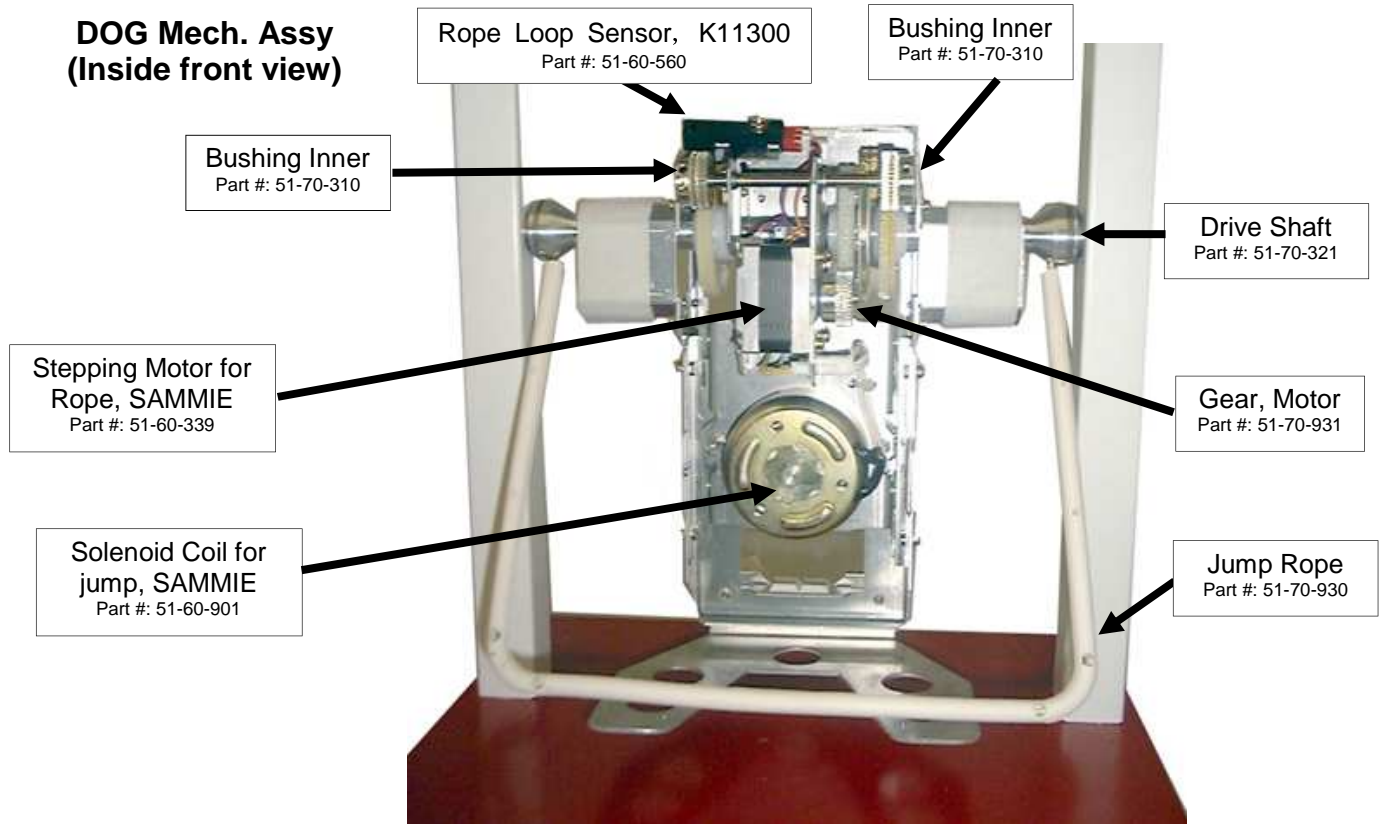

DOG Mech. Assy (Inside back view)

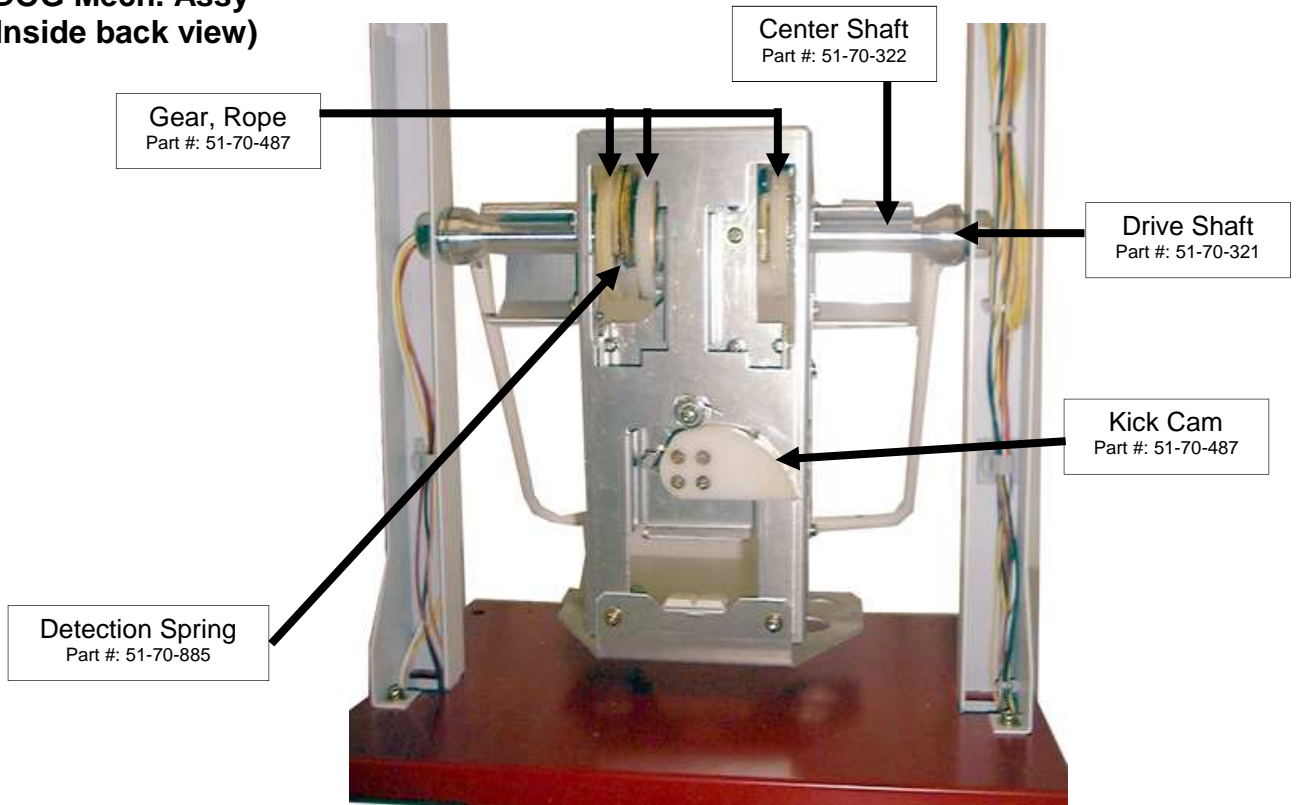

OPTION (BULK HOPPER UNIT, DBA, SECURITY BAR KIT)

BULK HOPPER UNIT (Option Parts for Capsule size change)
Default is 2" Bulk Hopper unit. Payout 2" of Capsule, Gumballs and Super ball.

(Ask Sammy USA Corporation if you want to change size of Bulk Hopper dispense. There are 1", 3" and 4" dia. available.

DBA (OPTION)

Cable of DBA is prepared already in cabinet. (9 pin connector near the hinge of upper coin door)

Set up DIPSW of DBA to all OFF.

SECURITY BAR KIT (OPTION)

Cabinet already has 4 of Carriage bolts both side of coin door that use for mounting Security Bar.



ELECTRICAL WIRING DIAGRAM (USA & CANADA)

ELECTRICAL WIRING DIAGRAM (EUROPE)