



# SEGA

## Kit Comments...

The update does a number of things that are much more than cosmetic.

1) The Beginner course is completely replaced with a new 'Pedal to the Metal' NASCAR track. The designers got rid of all the BS in the background, (waterfalls, Ferris wheels mountains etc.). They also changed the track layout making it a much better racing experience.

2) The Challenge Course. This track (referred to as the 4th course), starts the player out on the Advanced track. After one lap, the player races through a tunnel (there is no break in the action) and ends up coming out the other side on the Expert track. Players race one lap on the Expert track, enter a tunnel and again, without a break in the action, come out for one lap on the Beginner track. This may seem peculiar until you play it. Racing on the Advanced or Expert track takes quite a bit of skill; you constantly have to change gears, brake and maneuver through tight places. After doing that for the first 9/10ths of the race, ending on the NASCAR track with its high banks and wide track makes for a really exciting finish.

3) A 4th car. the designers blew the dust off the original Daytona Hornet and have made that an option for the players to select from. For the die hard Daytona I fans, this will be a real treat.

4) The time is now kept in thousandths of a second. With our upcoming Internet National Tournament System, ties between players became a problem.

5) A lot more chatter from the pit boss to the player. Not wanting to compliment another manufacturer, but.... Williams really hit the mark with NFL Blitz. The commentators might not get credit for making the game a success but I'm willing to bet if they weren't there, the game would not do as well as it does. We Sales guys noticed that and made the request to pick up the chatter coming from the pit boss. The end result is an added sense of reality and a raised sense of urgency. When the pit boss says "he's right on your tail" some players will be looking behind them.



SEGA Service Department  
45133 Industrial Drive  
Fremont Ca. <http://www.sgwservice.com>  
Phone: (650) 802-1750  
Fax: (650) 802-1754



## DAYTONA 2 USA POWER EDITION



**IMPORTANT:**

Before starting work be sure to turn power off. Failure to observe this can cause electric shock and short circuit hazards.

Use care so as not to damage wirings. Damaged wirings can cause electric shock or short circuit accidents.

This work should be performed by the Locations Maintenance Man or Serviceman. Performing work by those who do not have technical expertise can cause electric shock accident, or damage to the Game Board

### ***KIT INSTALLATION INSTRUCTIONS:***

- 1.) Turn power off & Disconnect all plugs from the Game Board Cage.*
- 2.) Remove Cage and open Case Lid.*
- 3.) Remove (12) phillips screws and remove the PCB from Cage.*
- 4.) Remove (4) phillips screws and nuts that secure Security Board to CPU Board. Remove Security Board.*
- 5.) Install new Security Board and secure with the (4) philips screws previously removed; DO NOT OVER TIGHTEN!*
- 6.) Remove each of the (41) E-Proms and Mask Roms from the Rom Board. Be careful not to scratch the Board or break sockets.*
- 7.) Install new E-Proms and Mask Roms. Be careful not to damage IC by static electricity. Be careful not to bend pins while inserting E-Proms and Mask Roms.*
- 8.) Re-install Game Board into cage, then replace cage into cabinet. Reconnect all connectors.*
- 9.) Power On Game and test for proper operation. Set all game options.*

Please see diagrams on the following page for E-PROM and ROM layout.

*If you have any questions please contact the SEGA Service Department at the numbers given above.*

[ CURRENT DAYTONA 2 USA E-PROM AND MASK ROM LAYOUT ]

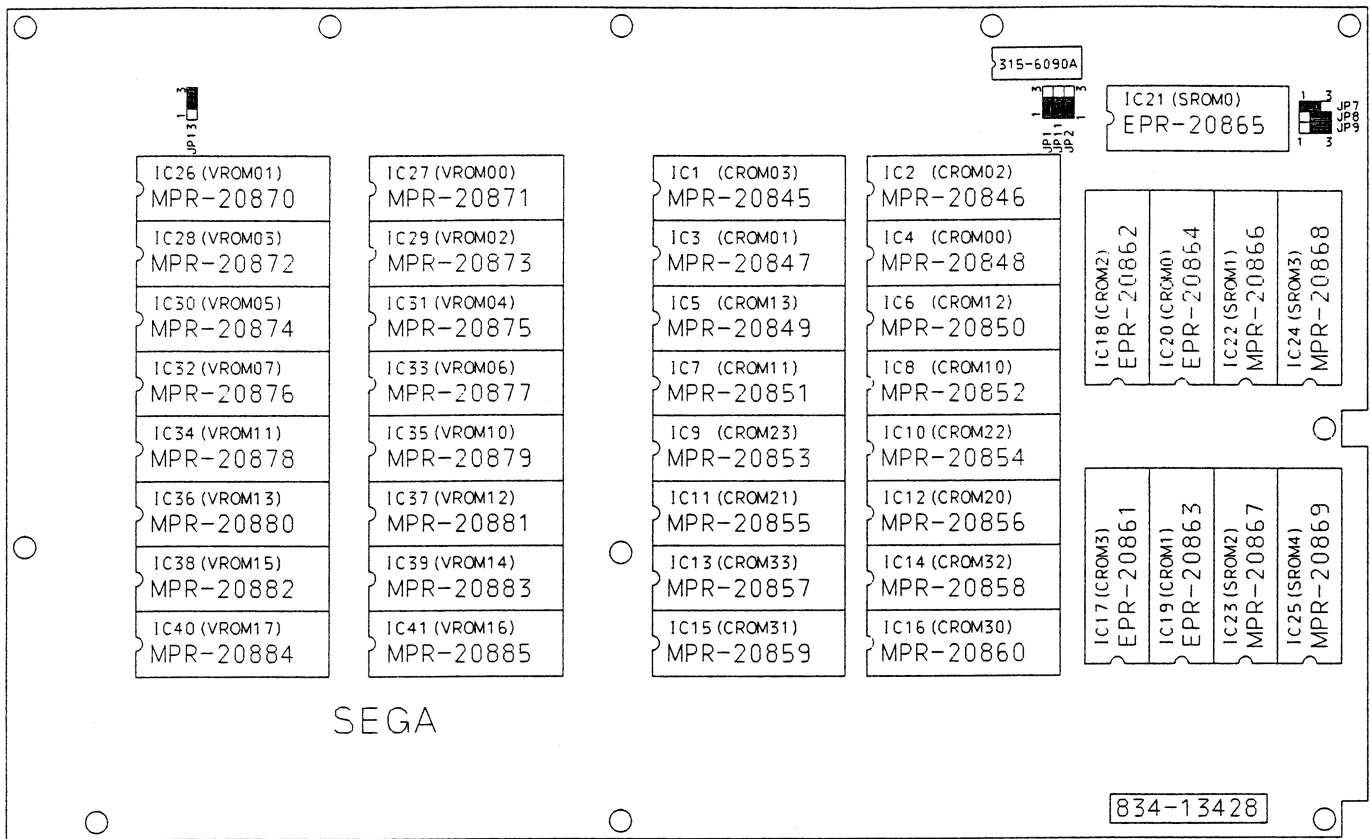

[ NEW DAYTONA 2 USA POWER EDITION E-PROM AND MASK ROM LAYOUT ]

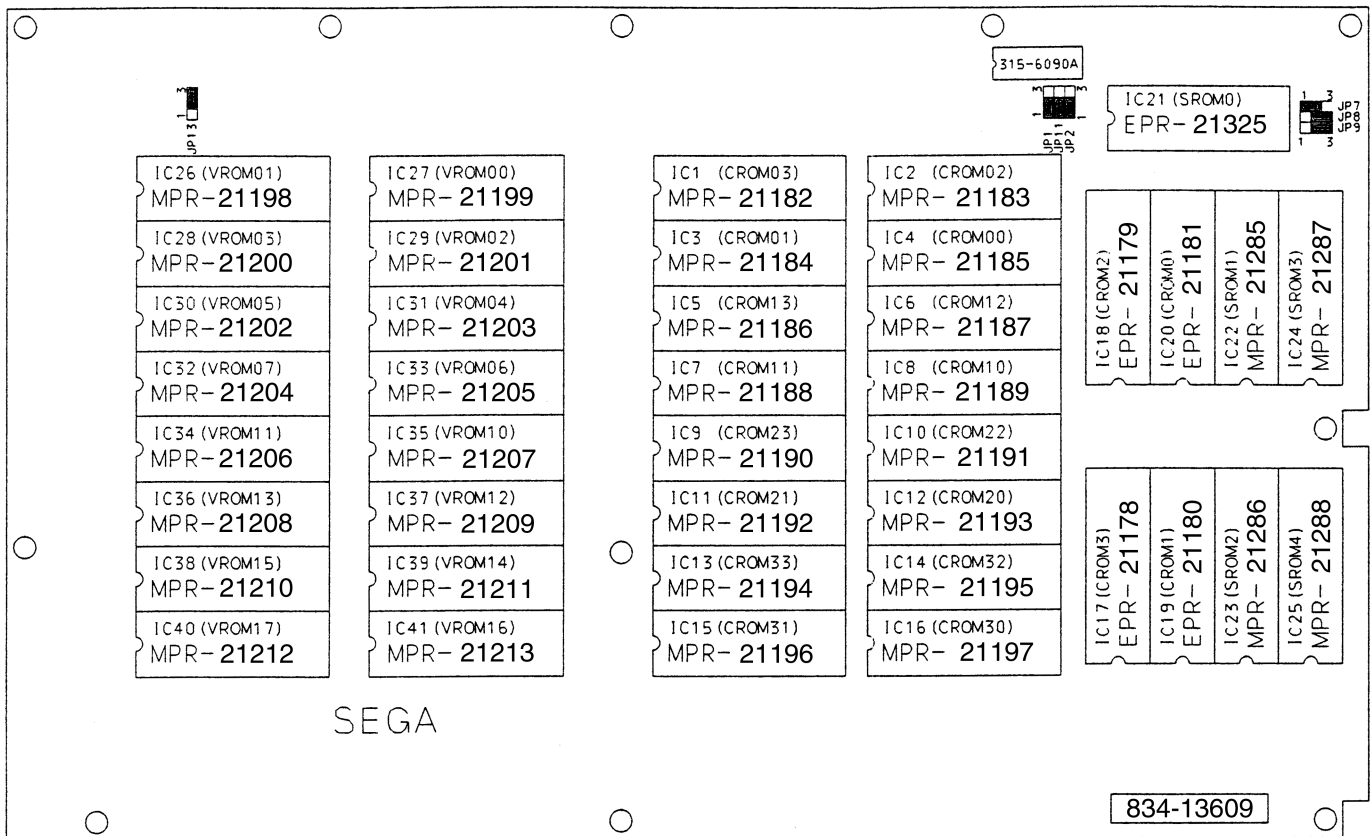

# COMPOSITION OF GAME BOARD

## GAME BD DAYTONA USA 2

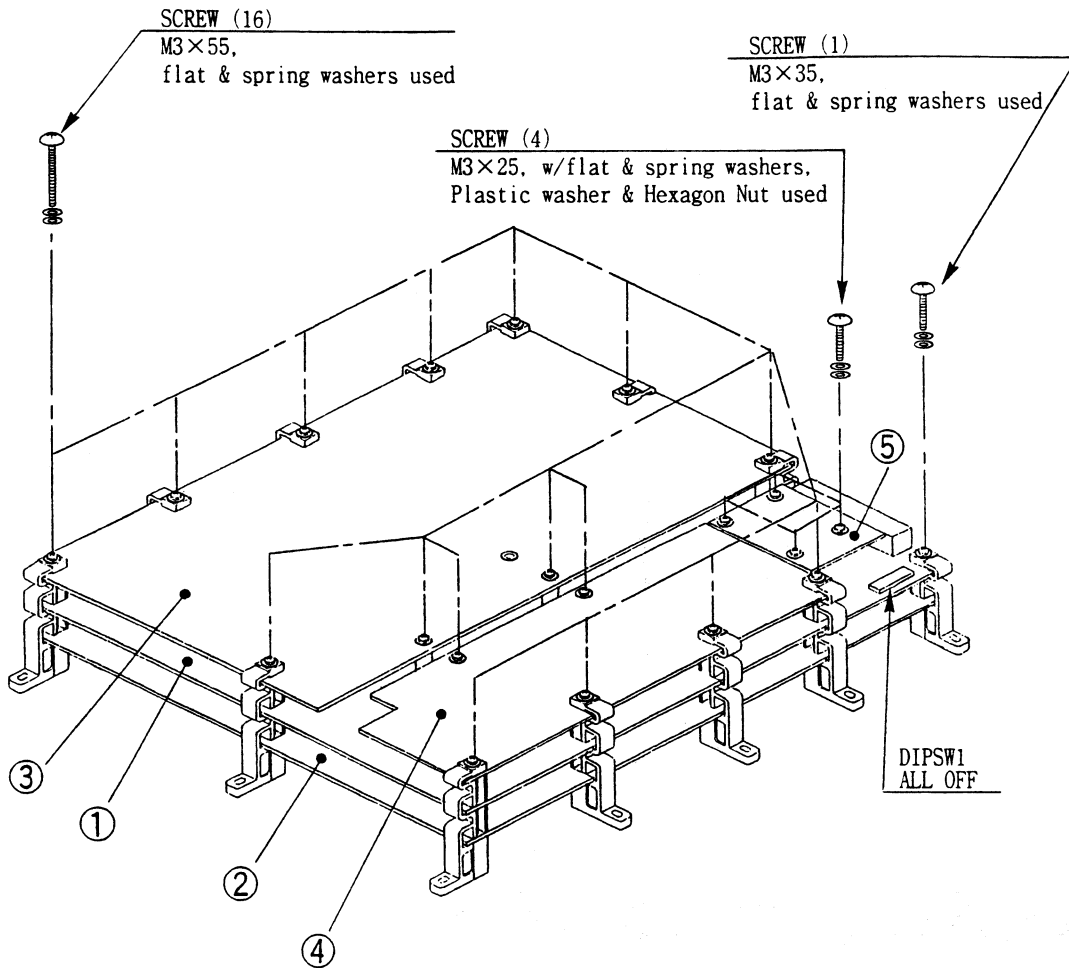

No.	PART No.	DESCRIPTION
①	837-12715-91	MODEL3 STEP2 CPU BOARD
②	837-12716-91	MODEL3 STEP2 VIDEO BOARD
	837-13368	MODEL3 STEP2.1 VIDEO BD
③	834-13428	ROM BD DAYTONA USA2
④	837-11861-91	MODEL3 COMM BD COM
⑤	837-13507-COM	PFSB SEC BD DUT COM



View of the POP panel included in this kit, NOTE: this may be shipped seperately from the ROM kit itself. This Panel will also include two of the mounting grips pictured at right to mount this to the top of the marquee.