

namco®



ACE DRIVER DELUXE

Operators Manual

**IT IS THE RESPONSIBILITY OF THE OPERATOR TO MAINTAIN CUSTOMER SAFETY
AT ALL TIMES, AND IT IS IMPERATIVE THAT THE DETAILS SET OUT IN THIS
MANUAL ARE FOLLOWED PRECISELY.**

SAFETY WARNING

In Order to Use This Machine Safely

In order to use this machine safely, be sure to read this Operators Manual and the Installation and Commissioning manual carefully before installation and use of the machine.

Whenever the owner of this machine entrusts disassembly, installation, adjustment, routine maintenance or trouble shooting to another person, the owner should ensure that they read the appropriate precautions and relevant sections of this manual before starting work.

In order that no accidents occur when the machine is in operation, strictly follow the notes on safety described below. Also, carefully read section 3, "Precautions".

Warnings for Operation

- NOTE:** Only operate this machine after checking that it has been installed correctly and in accordance with the Installation and Commissioning manual.
- NOTE:** Parts of this machine move during game play, so there are places where the distance between the stationary section and moveable section changes. There are warning stickers to keep hands and feet clear of moving parts, however if the operator feels that a customer playing the game is in any danger, he should warn the customer accordingly.
- NOTE:** The warning stickers must always be kept in good condition and replaced if worn so that the customer can read them clearly.
- NOTE:** **If there is an error or problem with this machine, operation must be stopped immediately.** (If the Drive Castor is worn out, it should be handled according to section 6-9, "Handling Drive Castor Wear".)

Warnings for Disassembly, Installation, Routine Maintenance and Troubleshooting

- DANGER:** Namco Ltd. bears absolutely no responsibility for accidents or injuries resulting from unauthorized changes to the machine.
- DANGER:** Ensure that the machine has been turned **OFF** before making adjustments or carrying out maintenance. Also ensure only qualified personnel carry out maintenance or turn the power **ON** to this machine.
- DANGER:** The power supply and inside the monitor will remain hot and have areas of high voltage even though the machine has been turned OFF, and there is a possibility of burns or electric shock. Be careful not to touch these areas.
- DANGER:** In order to avoid injuries due to mis-operation, be sure that the voltage of the power supply is within the prescribed limits. Also to prevent possible electric shocks due to failure, this machine **MUST** be fitted with a securely connected earthed plug.
- NOTE:** Do not turn the main power switch **ON** until the machine has been installed correctly.

© 1994 **namco**[®] Ltd - all rights reserved.

No part of this publication may be reproduced by any mechanical, photographic or electronic process, or in the form of phonographic recording, nor may it be stored in a retrieval system, transmitted or otherwise copied for public or private use, without permission from **namco** Ltd.

While the information contained in this manual is given in good faith and was accurate at the time of publication, BRENT LEISURE LIMITED reserve the right to make changes and alterations without notice.

This machine has been manufactured in accordance with European Community directives (1st. January 1995), and as such bears the **CE** marking. Any changes or modifications to this machine must be in accordance with European Community directives (1st. January 1995).

If you make any unauthorised changes to this product, you may contravene European Community directives (1st. January 1995)

Published by:
BRENT LEISURE Ltd.
Unit 1 Brent Crescent,
London. NW10 0QT

Phone:- 0181-965-0550
Fax:- 0181-961-0574

Contents

1.	HOW TO PLAY	1
2.	SPECIFICATIONS	2
3.	PRECAUTIONS	4
	3-1. Notes on Operation	4
	3-2 Notes on Installation	5
	3-3. Notes on Moving and Shipping	6
	3-4 Notes on Handling	7
4.	MAJOR COMPONENTS	8
5	ADJUSTMENTS	9
	5-1 Turning on the Power	9
	5-2 Adjustment Switches	9
	5-3 Test Mode	10
	5-3-1 Coin Options	11
	5-3-2 Game Options	12
	5-3-3 I/O Test	14
	5-3-4 Switch Test	15
	5-3-5 Motor Test.....	16
	5-3-6 Motion Stop Test	16
	5-3-7 Lamp Test.....	17
	5-3-8 LED Test.....	17
	5-3-9 Sound Test	18
	5-4 Linking Two or More Machines.	19
	5-4-1 Setting the Link Switches	20
	5-5 Adjustments When Replacing Parts (Initialization)	21
6.	MAINTENANCE	22
	6-1 Cleaning the Under Base	22
	6-2. Sign Assembly	23
	6-2-1. Replacing the Fluorescent Tube and Reflector Lamp	23
	6-2-2. Replacing the LED Drive PCB	23
	6-3. Main tower Assy.	24
	6-3-1. Replacing Fluorescent Lamp and Reflector Lamp	24
	6-3-2. Removing the Game PCB	24
	6-3-3. Removing the Shield Case	25
	6-3-4. Removing the I/O Board	25
	6-3-5 Replacing the Switch Mode Power Supply and Fuses.	26
	6-3-6 Replacing the Amplifier.	26

6-4. Removing the Monitor	27
6-5. Steering and Shift Lever	29
6-5-1. Replacing the Steering Wheel	29
6-5-2. Shift Assembly Maintenance	29
6-5-3. Replacing the Steering Drive PCB	30
6-5-4. Replacing the Time Belt	31
6-5-5. Replacing the Motor and Motor Brush	32
6-5-6. Replacing the Pulley	33
6-5-7. Replacing the Fuse	34
6-5-8. Replacing the Control Pot	34
6-6. Replacing the Seat	35
6-6-1. Removing the Seat	35
6-6-2. Installing the Seat	37
6-7. Under Base Assembly	38
6-7-1. Removing the Rear Covers (L), (R)	38
6-7-2. Names of Under Base Parts	39
6-7-3. Replacing the Drive Castor	39
6-7-4. Replacing the Drum Drive PCB and Motion Stop PCB	42
6-7-5. Replacing the V Belts	43
6-7-6. Replacing the Motor and Motor Brushes	44
6-7-7. Replacing the Motor Fuse	44
6-8. AB Pedal Assembly	45
6-8-1. Removing the AB Pedal Assembly	45
6-8-2. Replacing the Control Pots	45
6-9. Handling Drive Castor Wear	46
6-9-1. Checking drive Castor Wear	46
6-9-2. Action When the Drive Castor is Worn Out	46
7. TROUBLESHOOTING	47
8. PARTS	48
9. SCHEMATICS	90

1. HOW TO PLAY

- This machine is a multi-player racing game that allows several people to play at the same time, up to a maximum number of eight.
- When two or three players are competing against each other, the computer car is included and competition is between four cars.
When four or more players compete against each other, competition is amongst those players only.
When only one player is playing, he/she competes against the computer cars.

[Game Summary]

- The object of the game is to complete the set number of laps as fast as possible within the set time.
- The game is over after completing the set number of laps. The finishing position, lap time, and total time are displayed at the end of the game.
- If the set time runs out (becomes "0") before the laps are completed, the game is over.

[Starting the Game]

- Insert a coin/s. Move the shift lever up or down to select the method of shifting, AT (auto) or MT (manual) and then depress the accelerator.
- Next, move the shift lever up or down to select the level of difficulty (beginner, expert, expert (pro)) and then depress the accelerator. Expert (pro) is selected by selecting expert and depressing the accelerator while at the same time pressing the view change button. In a linked game expert (pro) class is set only if all participating players select it.
- After making selections, wait for the empty seat entry.
- A linked game starts when all of the connected seats have been entered, or when another player enters from another seat within twenty seconds after the coin/s have been inserted.
If there is no entry by another person within the twenty seconds, the game starts as a single player.
- A single player game can be started without waiting for other players by inserting a coin/s while pressing the view change button.

2. SPECIFICATIONS

POWER SUPPLY :- 220/240volts AC

POWER CONSUMPTION:- 720W

MONITOR :- Hantarex 28" Polo Colour Monitor with auto degauss.

DIMENSIONS :-

- Assembled: 2,370mm(w) x 2,180mm(d) x 2,200mm(h)
- Separated:
 - Seat Assy 1,070mm(w) x 2,030mm(d) x 1,640mm(h)
 - Tower Assy 2,100mm(w) x 850mm(d) x 1,760mm(h)
 - Header Assy 1,380mm(w) x 842mm(d) x 325mm(h)
 - Sign Boards 440mm(w) x 170mm(d) x 490mm(h)

WEIGHT:-

- Assembled: 1,112kg
- Separated:
 - Seat Assy 360kg (x2)
 - Tower Assy 348kg
 - Header Assy 32kg
 - Sign Boards 6kg (x2)

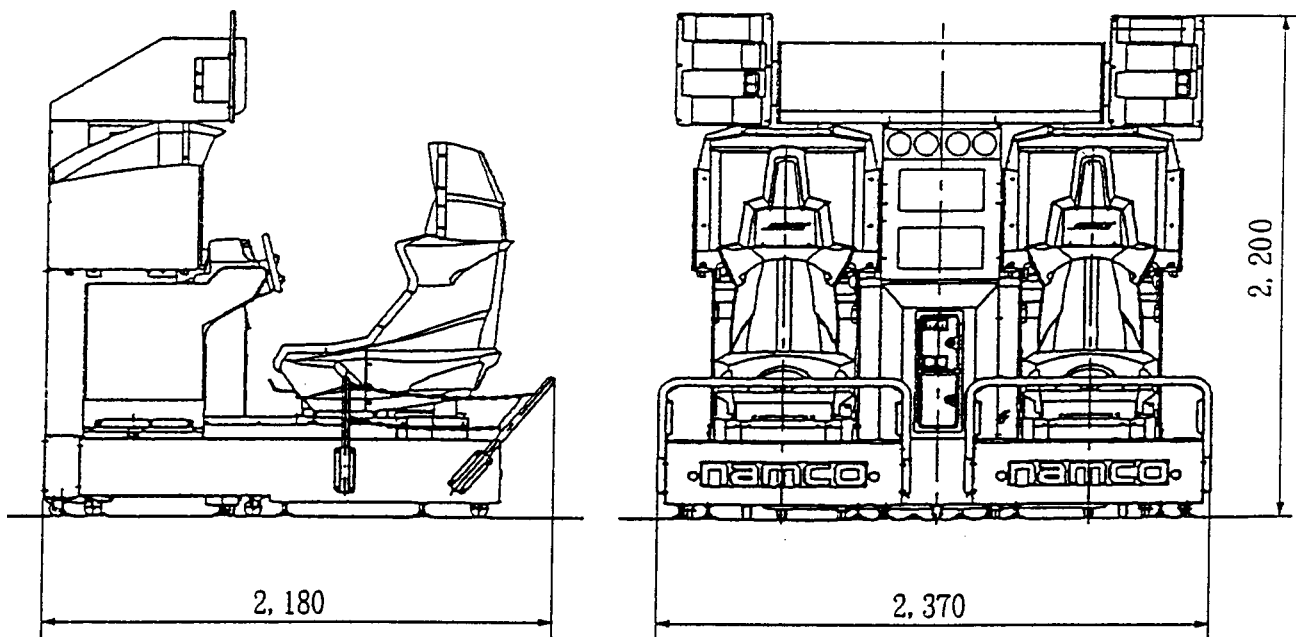

ACCESSORIES :-

Keys:	(Cash Door).....	2
	(Coin Door).....	2
	(Back Door)	2ea
IEC Mains Lead		1
Operators Manual.....		1
Installation & Commissioning Manual		1
Monitor Manual		1
Car Number Decal Set - Large		2
Car Number Decal Set - Small		1
M10 Security Wrench		1
M8 Security Wrench		1
M6 Security Wrench		1
M5 Security Wrench		1
Link Cable 6 metre		1
Steering Control Pot (Cont. Rotation)		1
Header Sign Board - LHS		1
Header Sign Board - RHS		1
Seat Base Extension Brkt - LHS/RHS		4
Floor Safety Mat - LHS		1
Floor Safety Mat - RHS		1
Floor Safety Mat - Centre		1
Rear Guard Fence.....		1
Rear Guard Fence Securing Brkt.....		4
Safety Skirt		2
Safety Skirt Stay		2
M10x25 Hex Head Screw		12
M10 Flat Washer - H/Duty		12
M10 Spring Washer Type B		12
M8x20 Security Button Head Screw		40
M8 Flat Washer - H/Duty		40
M8 Spring Washer Type B		40
M6x20 Security Button Head Screw		4
M5x16 Security Button Head Screw		6
M5x12 Security Button Head Screw		4
No6x½" Pozi Flange Head Screw		4

3. PRECAUTIONS

Be sure to read this section carefully

3-1. Notes on Operation

NOTE: Only operate this machine after checking that it has been installed correctly and in accordance with the Installation and Commissioning manual.

NOTE: The supplied guard fence is to ensure customers do not get too close to the machine or get injured. Make sure that the fence is fitted to the machine correctly and the rubber safety mats are in place.

NOTE: Parts of this machine move during game play, so there are places where the distance between the stationary section and moveable section changes. There are warning stickers to keep hands and feet clear of moving parts, however if the operator feels that a customer playing the game is in any danger, he should warn the customer accordingly.

NOTE: Ensure customers do not get hurt by leaning or climbing on the seat base or fence. Be especially careful in the case of young children.

NOTE: The warning stickers must always be kept in good condition and replaced if worn so that the customer can read them clearly.

NOTE: **If there is an error or problem with this machine, operation must be stopped immediately.**

Parts of this machine move to the left and right during the game. **In order to maintain the customer's safety**, the operator should strictly follow the appropriate precautions.

NOTE: **Ensure no items are placed on the seat base next to the seat assemblies to prevent damage to the machine.**

3-2 Notes on Installation

1. This machine is designed for indoor use only. **Do not** install the machine in the following places:

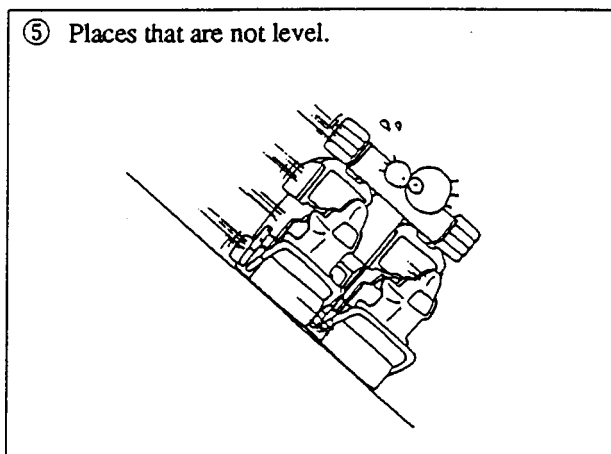
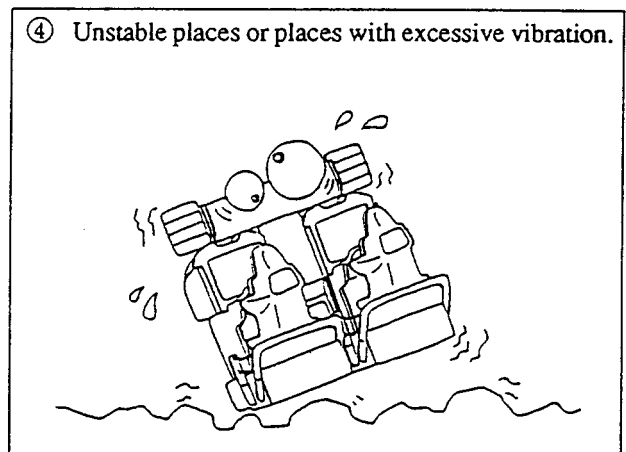
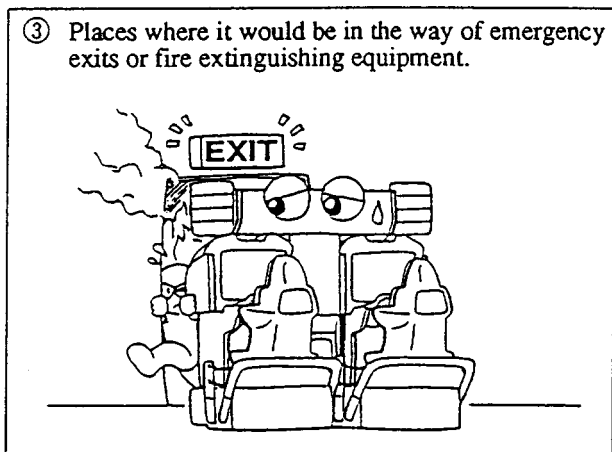
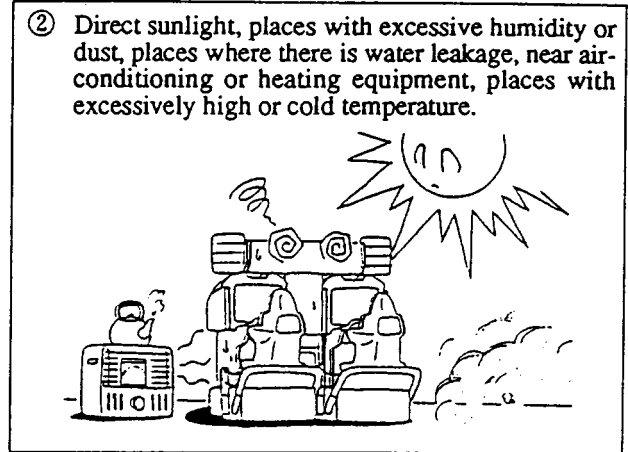
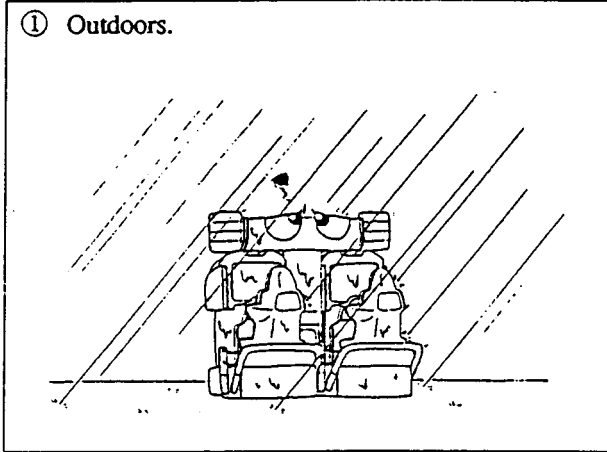

2. If this machine is installed next to walls or other machines, ensure there is plenty of space between them

NOTE: So that customers are not crushed or injured while the machine is moving, ensure that it is separated from walls or other machines by at least 30cm.

NOTE: In order that the PCB rack or power supply can be removed for service, make sure that the rear of the machine is separated from a wall or other machine by a distance of at least 50cm or more.

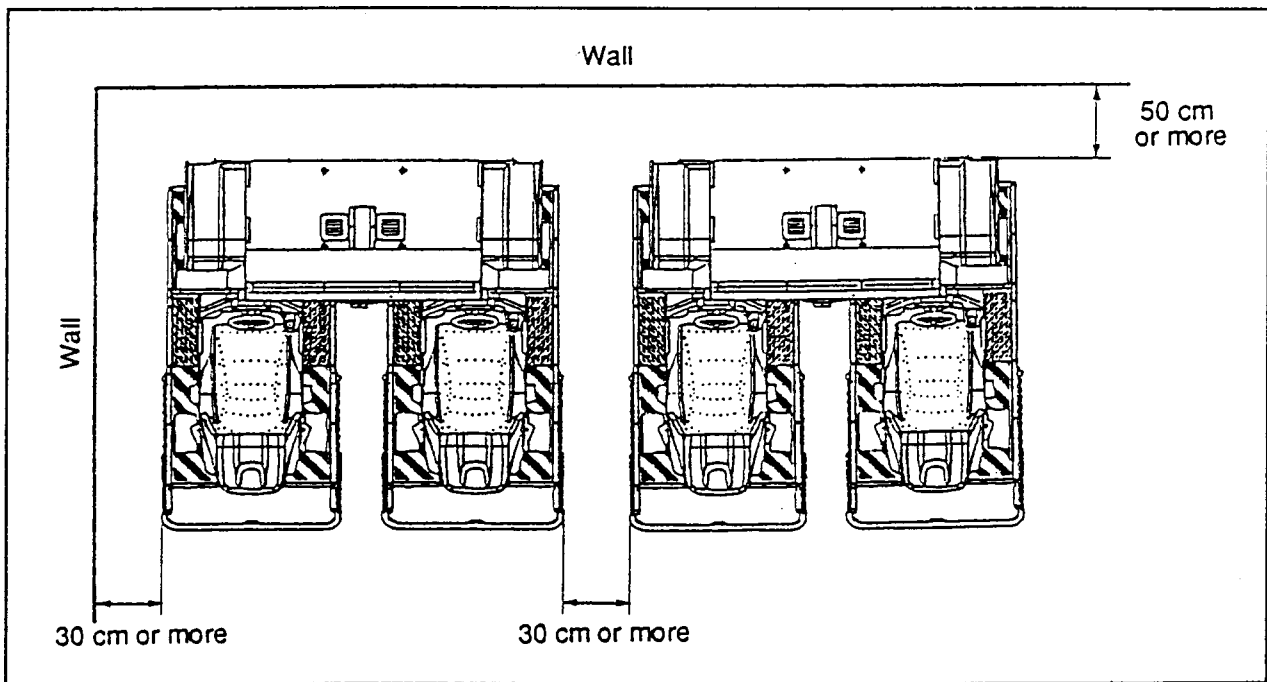

3-3. Notes on Moving and Shipping

NOTE: If the seat assembly is not secured to the seat base, there is a danger of the seat assembly moving left or right during shipping. Ensure that the shipping brackets (two for each seat assembly) are fitted securely.

NOTE: The tower assembly has a high centre of gravity and is unstable when standing alone. **Do not use a forklift** when moving or shipping.

- Take care not to damage the machine when moving or shipping.
- Take care not to rope moulded (plastic) parts when shipping.
- Ensure that the levellers are raised fully when moving the machine, even for short distances.
- The seat assy, tower assy and side boards must be separated when shipping.
- If a forklift is used to move the machine, use it only to move the seat assembly and only insert the forks in the places indicated on the side of the assembly.

3-4 Notes on Handling

- DANGER** The Mains voltage to this machine should be within the range of 220 to 240v AC and the transformer input matched accordingly.
- DANGER** Be sure that the power is turned **OFF** when replacing parts and connecting/disconnecting connectors.
- DANGER** to prevent possible electric shocks due to failure, this machine **MUST** be fitted with a securely connected earthed plug.
- DANGER** The monitor and power supply contain areas of very high voltage. Be extremely careful when inspecting or making adjustments.
- DANGER** When unplugging the game from an electrical outlet, always grasp the plug, not the mains lead.

NOTES:

- Always return PC Boards to your dealer for repair. Never test the PCB for continuity with a multimeter or similar device. The PCB contains sensitive devices which could be damaged or even destroyed by the internal voltage of such test equipment.
- Adjustments are required after replacing the game PCB, ROM, Steering Assy, AB Pedal Assy and control pots. Adjustments should be performed as described in section 5-4, "Adjustments when Replacing Parts" ([page 19](#)).
- After initial installation or if the number of machines linked together changes, it may be necessary to use the test mode to change the settings and link switch settings. (Refer to section 5-4, "Linking Two or More Machines" ([page 19](#)).

4. MAJOR COMPONENTS

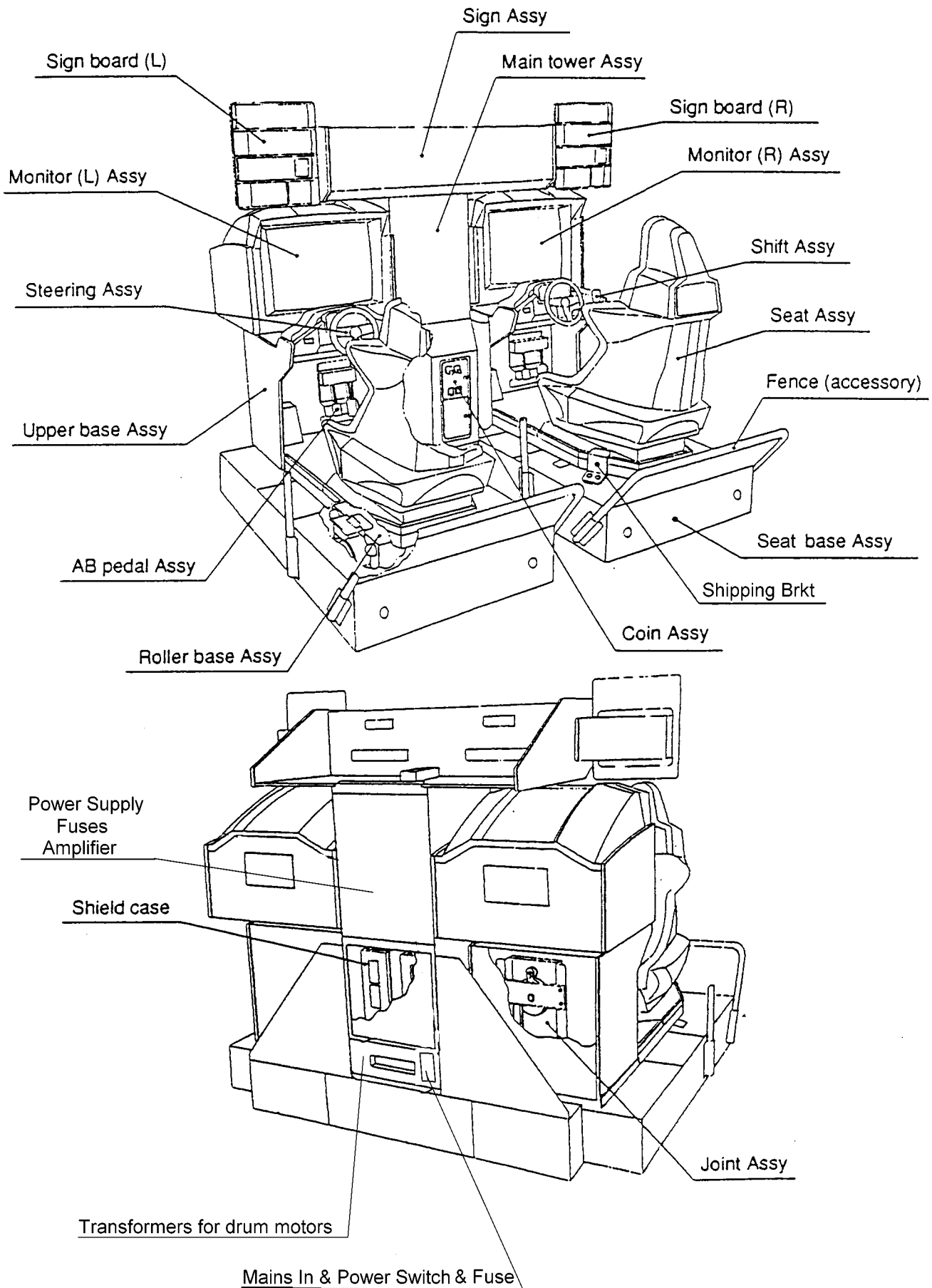

5 ADJUSTMENTS

5-1 Turning on the Power

After the machine has been installed, turn ON the power. The Power switch is located on the rear of the upper tower section. (See section 4 "Major Components" [\(page 8\)](#).)

5-2 Adjustment Switches

The adjustment switches are located inside the coin door.

1. Service Switch
Press this switch to obtain game credits without incrementing the play meters.
2. Test Switch
Slide this switch "ON" to enter test mode. Test mode allows game testing and the changing of game settings. (Refer to section 5-3 "Test Mode" [\(page 10\)](#).)

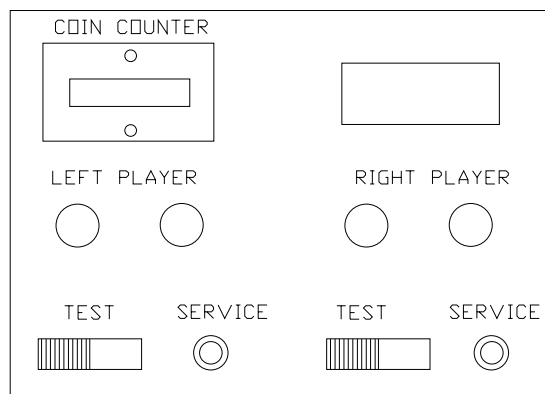

Service Bracket

5-3 Test Mode

1. Open the coin door and slide the test switch "ON". The "Menu Screen" will be displayed on the monitor.
2. Select the test required by moving the shift lever up or down. The colour of the selected test will change.
3. Enter the selected test by stepping on the accelerator. Select "EXIT" to return to the "Menu Screen" (step on the accelerator when using the monitor test screen).
4. After testing is completed, ensure that the test switch is returned to the "OFF" position to return to game mode.

The Test Switch must always be in the "OFF" position for normal game mode.

MENU	
COIN OPTIONS	----- (1) Sets the price of play. (See 5-3-1)
GAME OPTIONS	----- (2) Sets the game options. (See 5-3-2)
I/O TEST	----- (3) Used for testing the switches and motor. (See 5-3-3)
MONITOR TEST	----- (4) Used for adjusting the monitor.
SOUND TEST	----- (5) Used for adjusting the speaker volume. (See 5-3-9)
ADS DATA	----- (6) Displays the accumulated game data.
OTHERS	----- (7) Used for testing the PC boards and for initializing all of the settings.
GAS: ENTER SHIFT: CHOOSE	

5-3-1 Coin Options

- a. Select item (1) "COIN OPTIONS" on the menu screen, to set the game cost and related settings.
- b. Use the shift lever to select the required item then step on the accelerator.
- c. Use the shift lever to change the settings then step on the accelerator to store the new values.
- d. Select "EXIT" to return to the menu screen.

COIN OPTIONS [DEFAULT IN GREEN]	
GAME COST 1 COIN 1 CREDIT (a)
COIN1 MECH VALUE 1 COIN COUNT AS 1 COIN (b)
COIN MECH 2 VALUE 1 COIN COUNT AS 1 COIN (c)
BONUS FOR QUANTITY BUY IN NONE (d)
FREE PLAY OFF (e)
EXIT	
GAS: ENTER SHIFT: CHOOSE	

Note:- The price of play on this machine is set within the Cashflow Coin Mech. Ensure that the Coin Options on the screen are set as shown in the following table.

ITEM	CONTENTS	FACTORY SET
(a) Game Cost	Coins required for 1 credit - - - - - settable 1 - 9	1
(b) Coin 1 Mech Value	Number of pulses on meter per coin - - - - - settable 1 - 9	1
(c) Coin 2 Mech Value	Number of pulses on meter per coin - - - - - settable 1 - 9	1
(d) Bonus Coin	Extra coin pulse at specified coins in	NONE
(e) Free Play	Game started by pressing accelerator - - - - - Yes/No	NO

5-3-2 Game Options

- a. Select item (2) "GAME OPTIONS" on the menu screen to set the game options.
- b. Use the shift lever to select the required item then step on the accelerator.
- c. Use the shift lever to change the settings then step on the accelerator to store the new values.
- d. Select "EXIT" to return to the menu screen.

Note: Race Class (c) must be set first before changing items (d), (e), or (f).

GAME OPTIONS [DEFAULT IN GREEN]				
PCB ID NUMBER			 (a)
TEAM COLOUR		BLUE3	 (b)
RACE CLASS	BEG	EXP	PRO (c)
DIFFICULTY	B	B	B (d)
LAPS [LINK]	3	3	4 (e)
LAPS [SOLO]	3	3	4 (f)
SPEED DISPLAY			KM/H (g)
SOUND IN ATTRACT			ON (h)
EXIT				
GAS: ENTER		SHIFT: CHOOSE		

(See page 13 for descriptions)

NOTES

- **The rank (level of difficulty) and number of laps must be set the same on all positions that are linked.**
- **The PCB number of the seat furthest left (when facing the front of the machine) should be set to 1, and the other seats set to 2, 3, 4 and so on in order from left to right. The PCB number of the farthest right position should equal the number of positions linked.**
- **Settings other than those described will cause the machine to operate incorrectly.**

ITEM		DESCRIPTION		FACTORY SET
(a) PCB Number		The PCB number should be set so that none of the linked positions have the same number		
(b) Team Colour		RED 25 or 26 BLUE 3 or 4 YELLOW 17 or 18 GREEN 11 or 12 * When more than three sets (6 seats) are linked, different race numbers should be used for the same team colours.		
(c) Race Class	BEG	(d) Game difficulty level (time)	A (long) to D (short)	B
		(e) Number of laps (linked game)	3 to 6	3
		(f) Number of laps (solo play)	3 to 6	3
	EXP	(d) Game difficulty level (time)	A (long) to D (short)	B
		(e) Number of laps (linked game)	3 to 6	3
		(f) Number of laps (solo play)	3 to 6	3
	PRO	(d) Game difficulty level (time)	A (long) to D (short)	B
		(e) Number of laps (linked game)	3 to 6	4
		(f) Number of laps (solo play)	3 to 6	4
(g) Speedo Units		KM/H / MPH		MPH
(h) Attract Sound		ON / OFF		ON

5-3-3 I/O Test

1. Select item (3) "I/O TEST" on the menu screen.
2. Use the shift lever to select the required item then step on the accelerator.

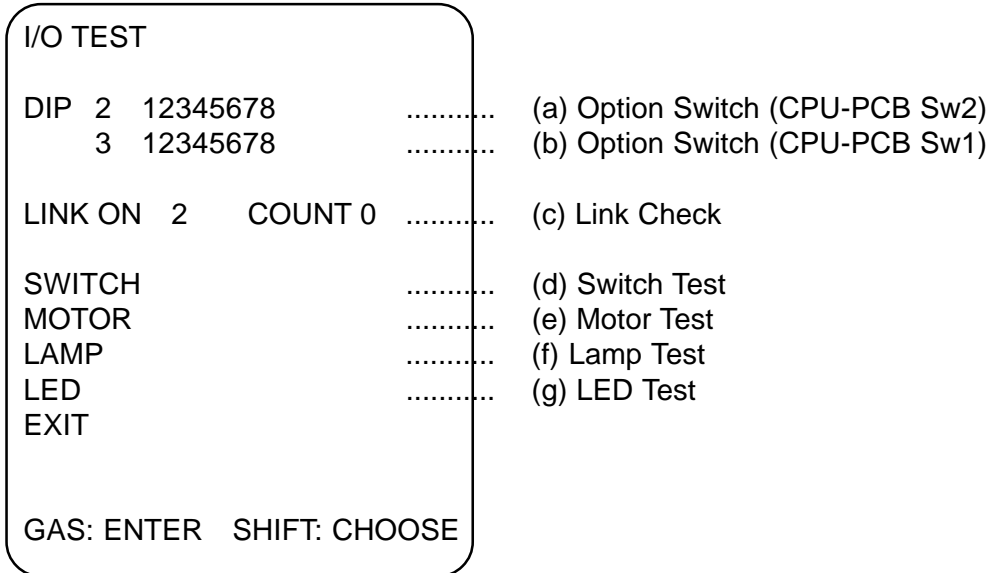

- (a) Displays the state of the option switch, SW2, on the game PC board (CPU-PCB).
- (b) Displays the state of the option switch, SW3, on the game PC board (CPU-PVB). For both items (a) and (b), the switch is ON when the numbers are shown in red.
- (c) Displays the number of positions linked. If there is a link error, "ERROR" is displayed. The numbers to the right of "COUNT", display the number of link errors detected during the I/O test.
- (d) Tests the switches. ([See 5-3-4.](#))
- (e) Tests the motors. ([See 5-3-5.](#))
- (f) Tests the lamps. ([See 5-3-7.](#))
- (g) Tests the LEDs. ([See 5-3-8.](#))

5-3-4 Switch Test

The following screen is displayed when "SWITCH" is selected on the I/O screen.

I/O TEST							
DIP		2	12345678				
		3	12345678				
LINK ON 2		COUNT 0					
SWITCH							
(a) Accelerator	GAS:	*0000	COIN 1:	OFF	(e) Coin 1 switch
(b) Brake	BRAKE	*0000	COIN 2:	OFF	(f) Coin 2 switch
(c) Steering	STEER	*0000	SERVICE:	OFF	(g) Service switch
(d) Shift	SHIFT	CENTRE	VIEW:	OFF	(h) View change switch
TO EXIT, STEP ON GAS AND SHIFT UP							

- (a) When the accelerator is stepped on, the number increases in the + direction.
- (b) When the brake is stepped on, the number increases in the + direction.
- (c) When the steering wheel is turned to the right, the number increases in the + direction, and when it is turned to the left, it increases in the - direction.

When items (a), (b), and (c) are in their middle position, "0000" is displayed. (It is normal for the last digit to change.) Just before the steering wheel is as far as it will go, or just before stepping on the accelerator or brake as far as they will go, "OK" will be displayed to the right of the number if everything is correct.

- (d) Displays the position of the shift lever (CENTRE, UP, DOWN) and the state of the switches.

When the shift lever is pressed forward, switch 1 goes "ON" and "DOWN" is displayed, and when it is pulled back, switch 2 goes "ON" and "UP" is displayed.

- (e) When coin 1 switch is operated, "ON" is displayed.
- (f) Unused.
- (g) Goes "ON" when the service switch inside the coin door is pressed.
- (h) Goes "ON" when the view change button is pressed

To return to the menu screen, move the shift lever up and step on the accelerator.

5-3-5 Motor Test

The following screen is displayed when "MOTOR" is selected on the I/O screen.

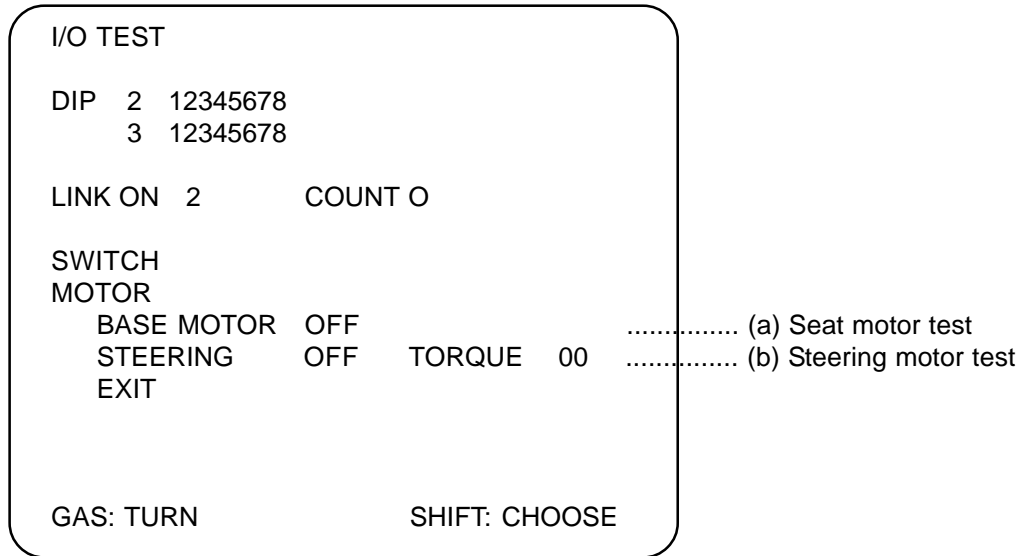

- (a) Tests the seat roller motor.

When "BASE MOTOR" is selected and the accelerator is pressed the test is "ON" and the motor starts to operate. Pressing the accelerator again turns the test "OFF" and the motor stops.

- (b) Tests the steering feedback motor.

When "STEERING" is selected and the accelerator is pressed the test is "ON" and the motor will start and turn the steering wheel left and right.

When performing this test, ensure that test (a) "BASE MOTOR" is also "ON".

Pressing the accelerator turns the test "OFF" and the motor will stop.

Select "EXIT" to return to the I/O test screen.

Note: Performing the steering motor test can be dangerous, sit on the seat properly, and take hands off the steering wheel.

5-3-6 Motion Stop Test

The Stop Motion Switches will illuminate as soon as the test switch is turned ON.

To test the motion stop switches enter motor test (Refer to section 5-3-5, "Motor Test" above.) and select Base Motor ON.

Each time a stop motion switch is pressed, the motor will stop and restart when the switch is released.

NOTE: If this switch is pressed during game mode, the seat motion will stop and stay off for the remaining duration of the game

5-3-7 Lamp Test

The following screen is displayed when "LAMP" is selected on the I/O screen.

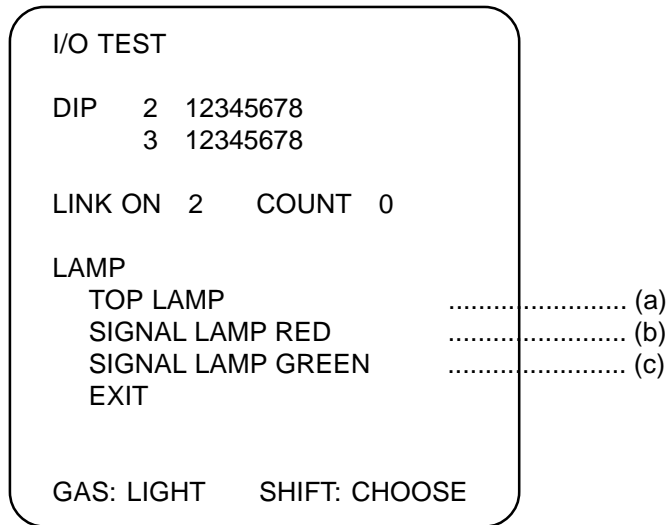

- (a) Tests the top lamp.
- (b) Tests the red signal lamp.
- (c) Tests the green signal lamp.

Select "EXIT" to return to the I/O test screen.

5-3-8 LED Test

The following screen appears when "LED" is selected on the I/O test screen.

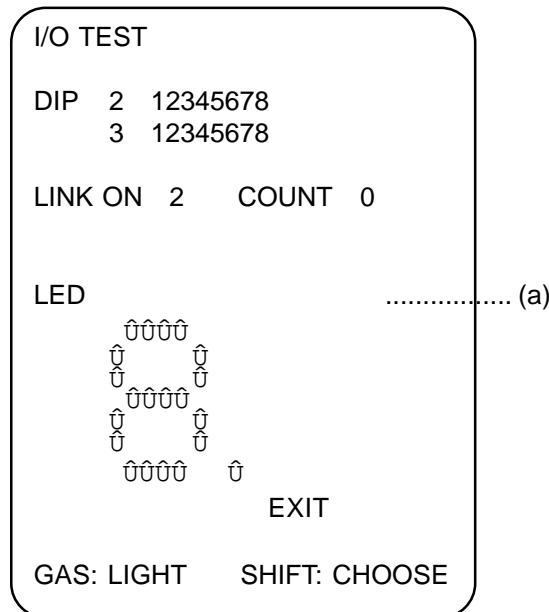

- (a) Tests the finish position LED.

Select "EXIT" to return to the I/O test screen.

5-3-9 Sound Test

To adjust the sound volume, select "SOUND TEST" in the menu screen. The following screen will be displayed.

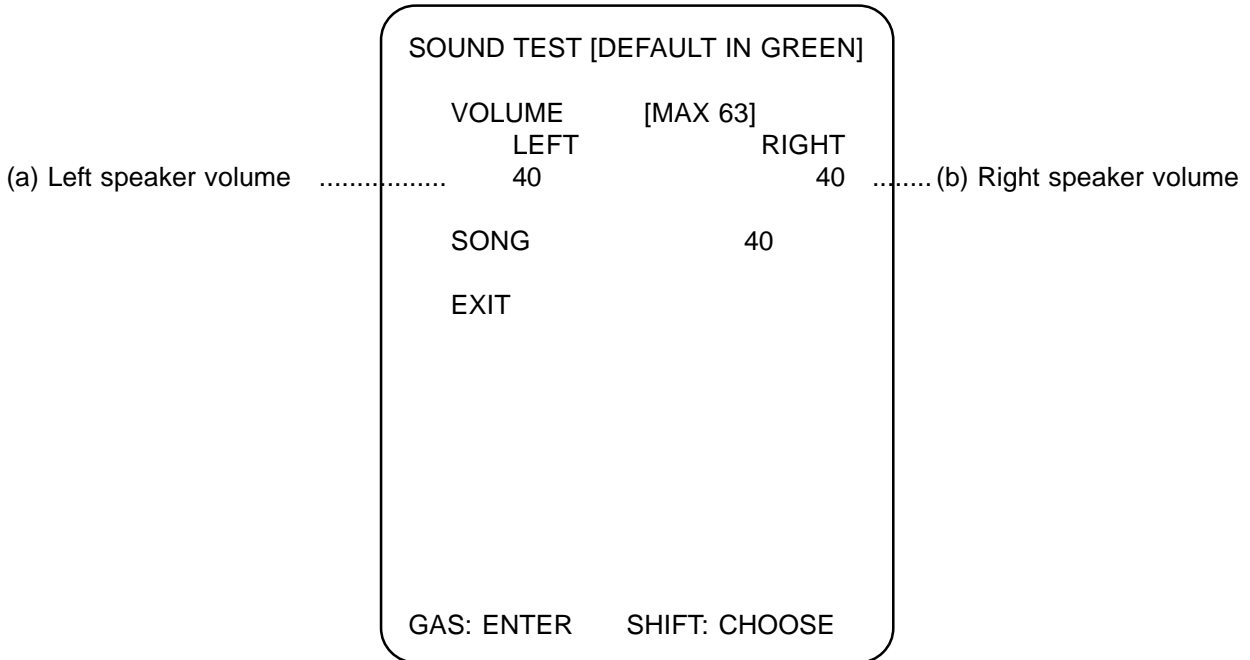

Select (a) or (b) by using the shift lever, the characters will blink in red, when the accelerator is pressed the numbers will start to blink. Moving the shift lever up will increase the number, moving the shift lever down will decrease the number.

The volume can be adjusted in 64 steps, with 00 the lowest and 63 the loudest. The factory setting is "40"

Select "EXIT" to return to the menu screen

5-4 Linking Two or More Machines.

Up to four machines (8 seats) can be linked together.
The machines should be linked as described below.

NOTE: Each machine can draw up to 8 amps. Make sure that the power supply is adequate.

- 1) Ensure that the power is "OFF".
- 2) Loosen the two screws (M4x10) on the back of the tower assy, and remove the connector cover.

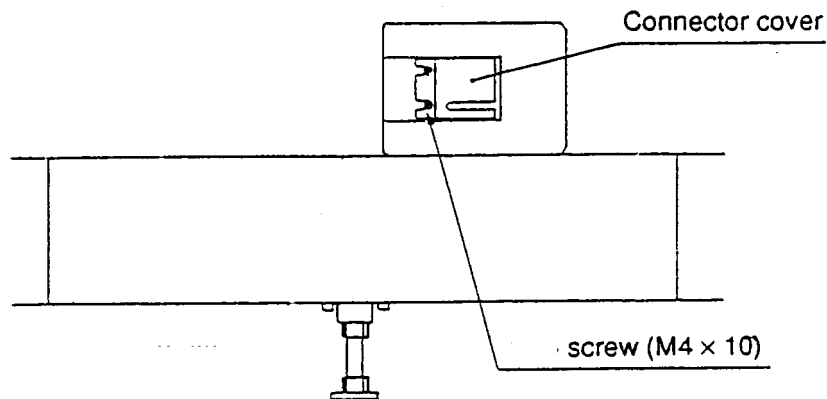

- 3) Set the link switches to "ON", "EXT", and "ON". (See Diag.)
- 4) Use the supplied link cable and connect the machines between "IN" and "OUT" sockets (See Diag.)

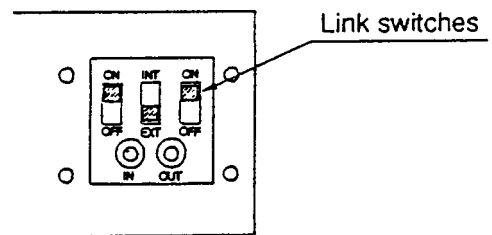

[Examples of Linked Machines]

- a) 2 Machines
(4 Seats)

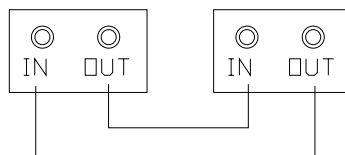

- b) 3 Machines
(6 Seats)

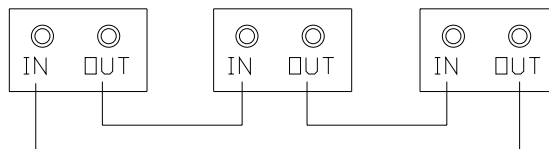

- c) 4 Machines
(8 Seats)

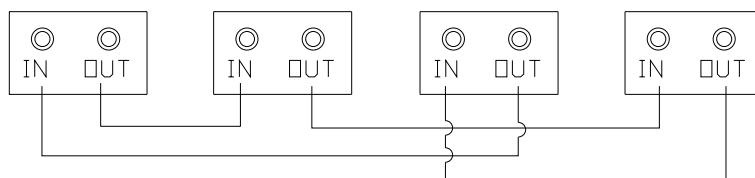

- 5) Turn the power to each machine "ON", and set the PCB ID using the test mode.
(Refer to section 5-3-2, "Setting the Game Options" (page 11))

Note: Settings other than those described will cause the machine to operate incorrectly.

5-4-1 Setting the Link Switches

The link switches are used to set the connection between seats and machines.

- 1). Setting only one machine (2 seats)

Set the link switches to "ON", "INT", and "ON".

Note: Do not use a link cable.

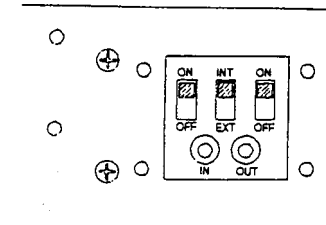

- 2) Setting two or more machines.

Set the link switches to "ON", "EXT", and "ON".

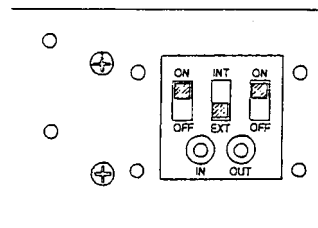

- 3) Install the connector cover using the two screws (M4x10).

The link procedure is now complete.

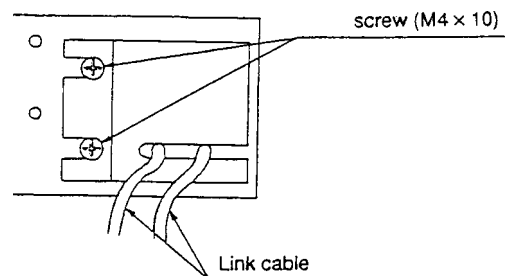

- 4) Setting for faulty PCB.

If the game PCB of only one side is faulty, set the link on that side to "OFF".

[Example of setting for faulty left side]

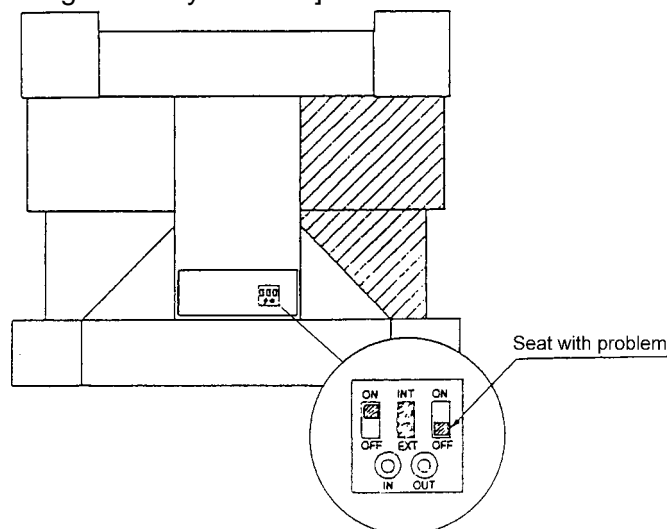

5-5 Adjustments When Replacing Parts (Initialization)

The following adjustments should always be performed after replacing the game PC board, ROM, Steering Assy, Pedal Assy, or Control Pots.

The game will not operate correctly if these adjustments are not made.

- a) Ensure that accelerator and brake pedals are fully returned.
- b) Place the steering wheel to it's centre position and remove hands from the wheel
(*The steering wheel does not return to centre by itself.*)
- c) Slide the test switch "ON" while pressing the service switch. The following

ADJUST MODE			
	BASE	BIAS	VALUE
STEER:	****	****	0000
GAS:	****	****	0000
BRAKE:	****	****	0000

ADJUST WHILE PRESSING
SERVICE SWITCH.
TO EXIT, TURN OFF TEST SWITCH.

screen will be displayed on the monitor.

- d) Press the service switch to reset all values to 0000
- e) Fully depress and release the accelerator, then the brake, then turn the steering wheel fully left and right.
- f) Slide the test switch "OFF" to return to normal game mode.

***** If the above initialization does not perform correctly, repeat two or three times.

6. MAINTENANCE

DANGER: In order to prevent injury or electric shock to service personnel, ensure that the MAIN POWER IS OFF before attempting any maintenance.

DANGER: Before performing any work not described in this manual, be sure to contact your distributor first to receive instructions or answers to questions.

NOTE: This machine has a moving mechanism, and uses a drive castor in the base assy (see section 6-7, "Under Base Assy"). When the castor wears out, the seat assembly can be moved left to right easily by hand.

Turn OFF the motor power switch in the base assy and secure the movable seat assy using the shipping brackets until the castor has been replaced with a new one. (Refer to section 6-9, "Handling Drive Castor Wear".)

NOTE: As the drive castor wears, worn material is deposited in the base assy and should be removed approximately once a month. (Refer to section 6-1, "Cleaning the Under Base".)

6-1 Cleaning the Under Base

The worn material from the drive castor should be removed once a month.

- 1) Switch the power OFF
- 2) Remove the rear covers (L), (R).
(Refer to section 6-7-1, "Removing the Rear Covers (L), (R)")
- 3) Move the seat assy by hand, and use a vacuum cleaner to remove the worn material that has collected under the roller. (Refer to section 6-7, "Under Base Assy".)

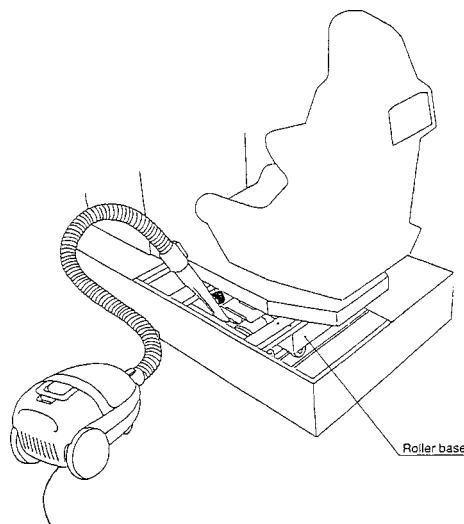

6-2. Sign Assembly

6-2-1. Replacing the Fluorescent Tube and Reflector Lamp

- 1) Remove the two security screws (M5x12) and remove the acrylic retainer (B).
- 2) Remove the four Security screws (M5x12) and remove the acrylic retainer (C).
- 3) Pull the acrylic sign forward to remove it.
- 4) Replace the fluorescent lamp 4ft..
- 5) Unscrew the reflector lamp (240v 25w E14 only) to the left to remove. Refit by screwing the lamp to the right. (*Warning: Make sure the lamp is not hot*)

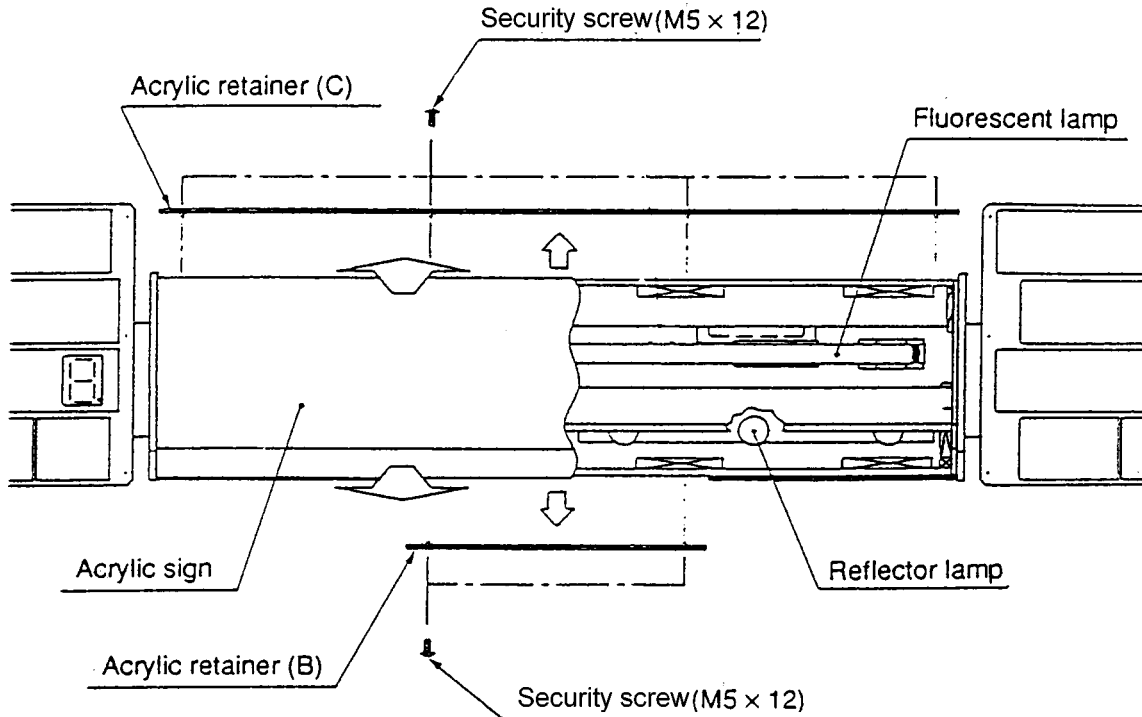

before touching it.)

6-2-2. Replacing the LED Drive PCB

- 6) Remove the four security screws (M6x16), and remove the sign board.
- 7) Disconnect the connector.
- 8) Carefully close the support locking ramp with pliers, and gently remove the board from each support in turn. Replace the board by pushing gently pushing the board on to each support.

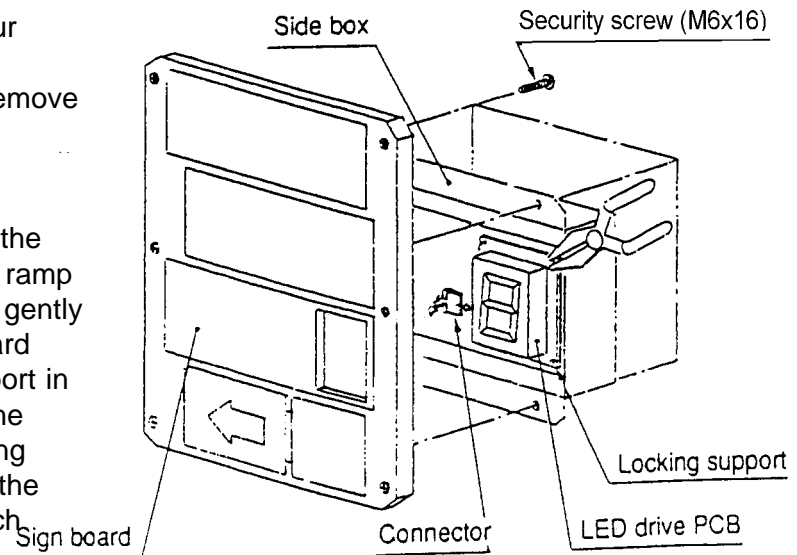

6-3. Main tower Assy.

6-3-1. Replacing Fluorescent Lamp and Reflector Lamp

- 1) Remove the four security screws (M5x12) and the acrylic support bar, then remove the acrylic board.
- 2) Replace the fluorescent lamp (12").
- 3) Unscrew the reflector lamp (240v 25w E14 only) to the left to remove. Refit by screwing the lamp to the right. (*Warning: Make sure the lamp is not hot before touching it.*)

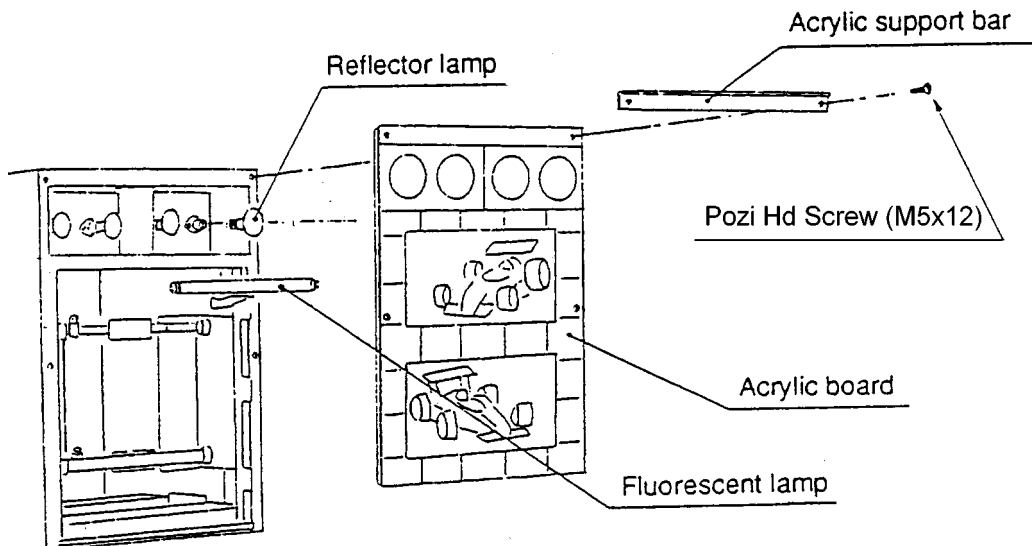

6-3-2. Removing the Game PCB

- 1) Remove the rear cover (L).
- 2) Disconnect the two connectors on the EMI board. Remove the six pozi head screws (M4x10) to remove the shield case door and earth terminal, being very careful of the connector that connects the EMI board and Game PCB, then remove the Game PCB.

Note: Be careful not to lose the internal washer (M4).

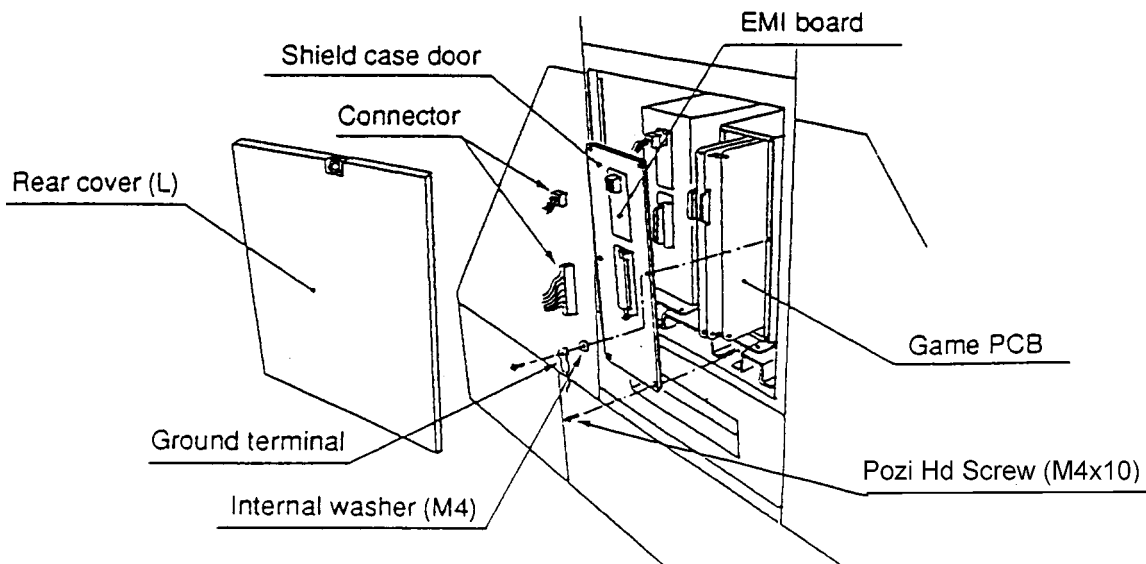

6-3-3. Removing the Shield Case

- 1) Remove the rear cover (L).
- 2) Remove the Pozi head screw (M4x10), and remove the earth terminal.
(Note: Be careful not to lose the internal washer (M4).)
- 3) Disconnect the two connectors on the EMI board, the AC fan connector, and the four connectors on the I/O PCB.
- 4) Remove the two Pozi head screws (M5x12), then remove the shield case.

6-3-4. Removing the I/O Board

- 1) Pull out the shield case until the I/O board can be seen.
(Refer to section 6-3-3, above, "Removing the Shield Case".)
- 2) Remove the four Pozi head screws (M3x20).
(Note: Be careful not to lose the four nylon spacers.)
- 3) Remove the I/O PCB.

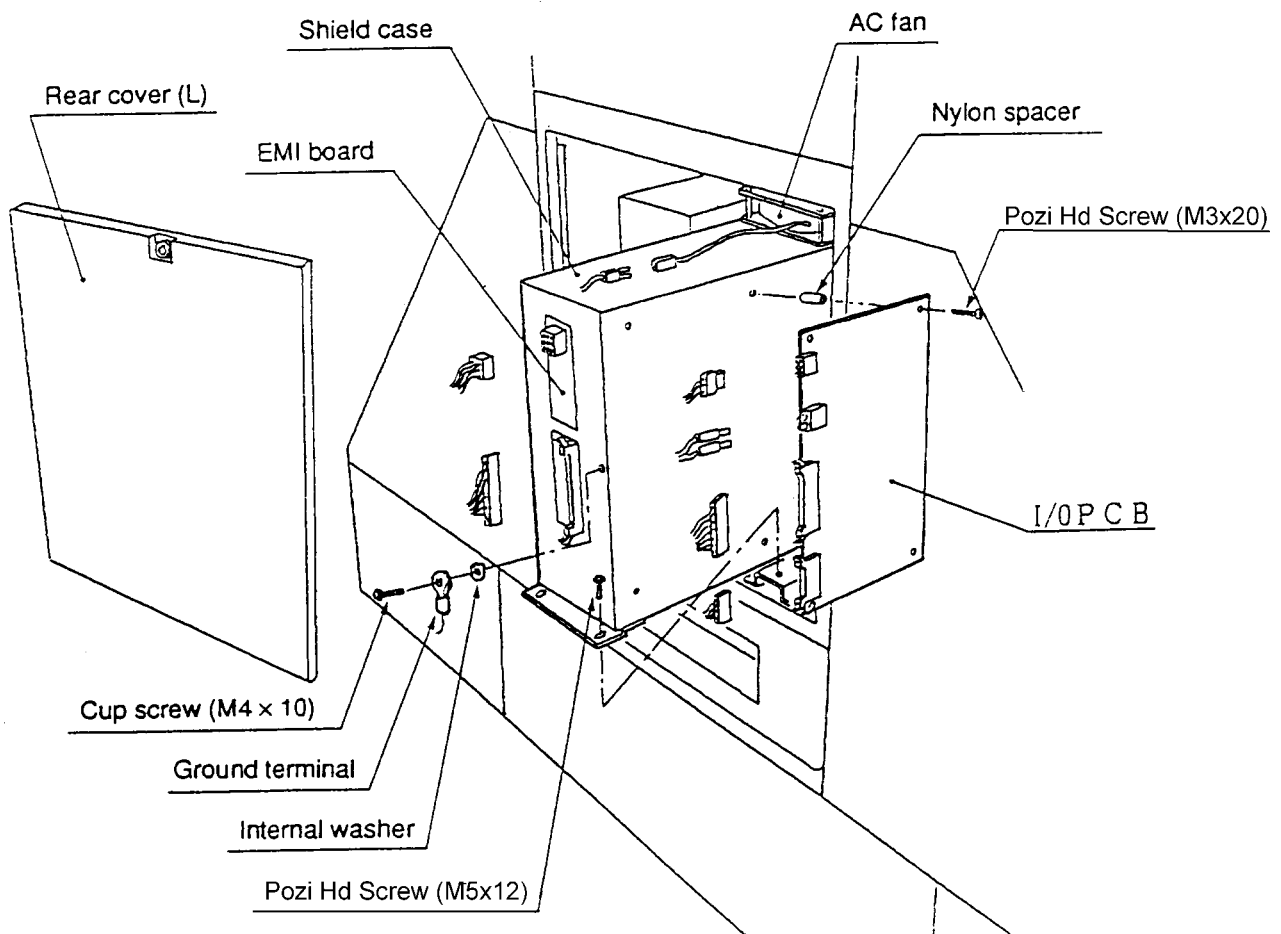

6-3-5 Replacing the Switch Mode Power Supply and Fuses.

- 1) Remove six security screws (M5x12), and remove the upper rear panel from the tower unit.
- 2) Partially slide the power supply wooden tray backwards to gain access to the fuses.
- 3) Disconnect all connectors, and remove the wooden tray completely.
- 4) Replace the power supply assembly.

6-3-6 Replacing the Amplifier.

- 1) Remove six security screws (M5x12), and remove the upper rear panel from the tower unit.
- 2) Partially slide the amplifier wooden tray backwards.
- 3) Disconnect all connectors from the amplifier, and remove the wooden tray completely.
- 4) Replace the amplifier.

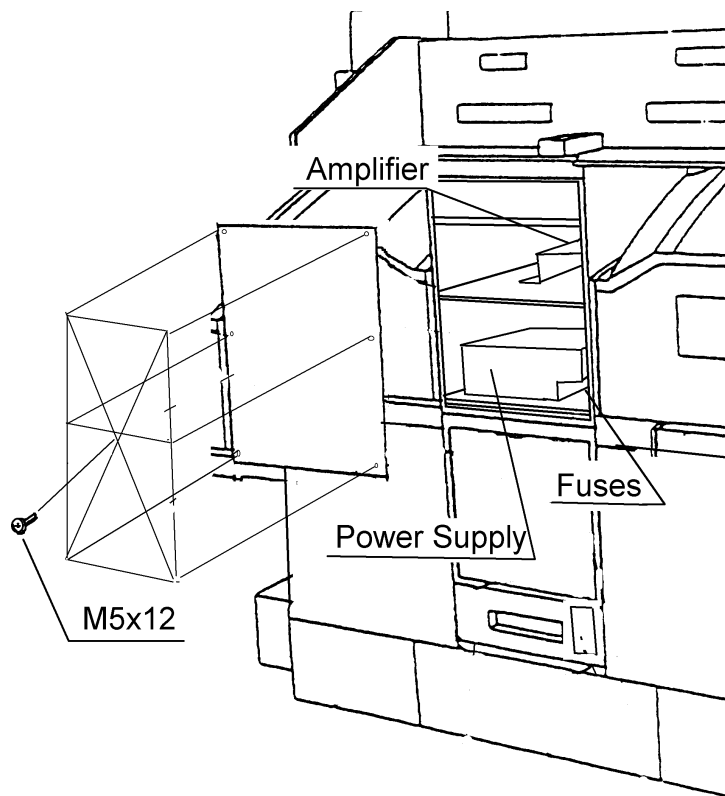

6-4. Removing the Monitor

DANGER: There are areas within the monitor that have high temperature and very high voltage even after the power has been removed. Extreme care must be taken to avoid burns or electric shock.

DANGER: The monitor weighs approx 60kg, at least two people should be used to remove the monitors.

- 1) Ensure that the power is turned OFF before removing the monitors.
- 2) Remove the back door from the monitor.
- 3) Disconnect the six way video connector and three way power connector.
Remove the hex head screw (M4x10) retaining the earth terminal.
- 4) Remove the six security screws (M5x12) on the rear of the main tower assy, and remove the rear cover (U).
- 5) Remove the wiring leading from the main tower to the monitor assy.
- 6) Remove the four security screws (M5x12) on the front of the main tower assy, and remove the acrylic fastener bar and acrylic sheet.
- 7) The monitor is fastened on the side and bottom to the main tower assy. Remove the following bolts:
Side: Five hex head bolts (M8x45), flat and safety washers.
Bottom: Two hex head bolts (M8x25), flat and safety washers.

WARNING: If the seat assemblies are not fitted to the tower and only one monitor is being removed, the tower assembly will be unstable, so remove both monitor assemblies.

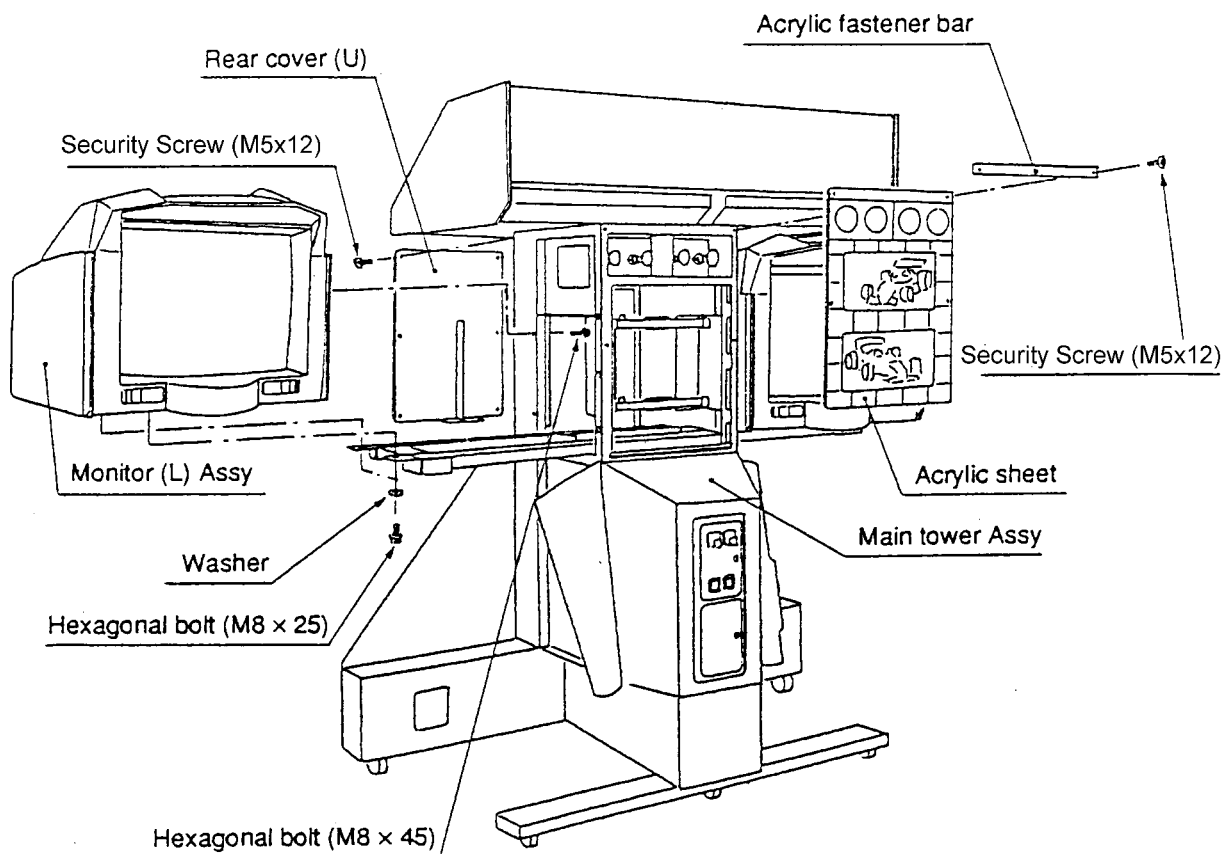

- 8) Remove the four security screws (M5x20) connecting the monitor mask to the monitor cover.
- 9) Remove the six security screws (M5x20) which fasten the monitor mask to the monitor box, and remove the monitor mask.
- 10) Remove the three security screws (M5x20) which fasten the monitor cover to the monitor box, and remove the monitor cover.
- 11) Remove the four hex head bolts (M8x20), and withdraw the monitor from the front.

Note: Remember the monitor is heavy, approx 40kg, use two people.

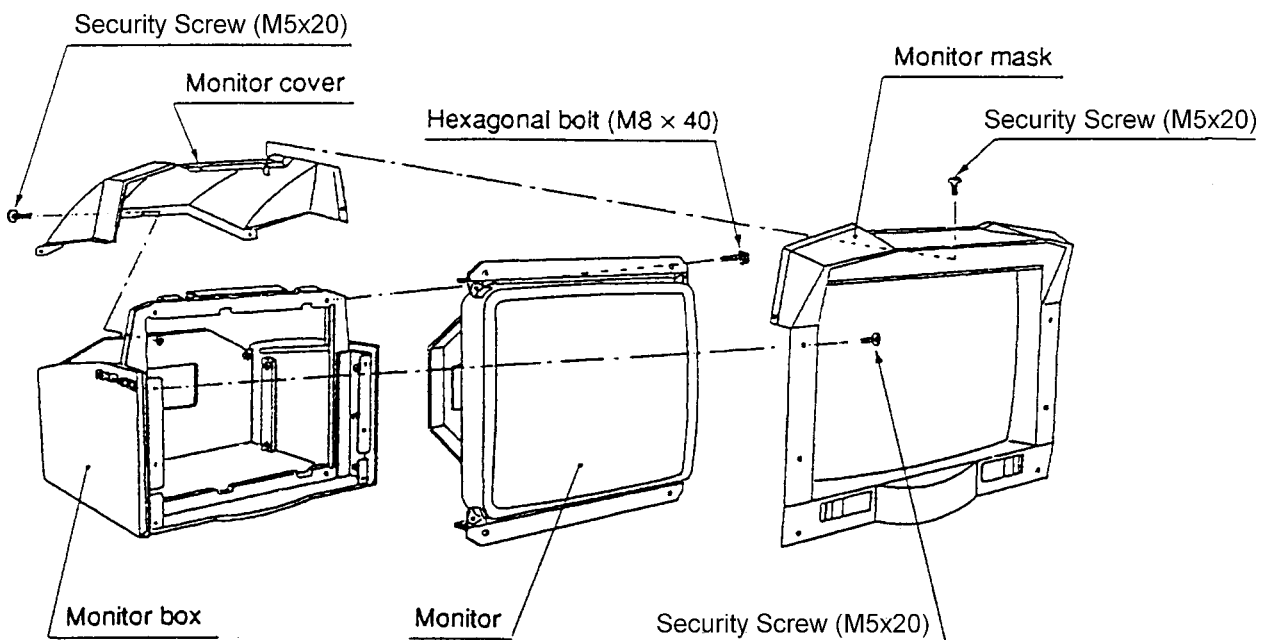

6-5. Steering and Shift Lever

6-5-1. Replacing the Steering Wheel

- 1) Remove the three security screws (M6x20), and remove the steering wheel.
- 2) When refitting the steering wheel, ensure that the keyway between the steering boss and shaft is at the bottom, and take care that the wheel is fitted at the correct angle.

6-5-2. Shift Assembly Maintenance

- 1) Removing the Shift assembly
 - a). Remove the four security screws (M6x16), and withdraw the shift assembly.

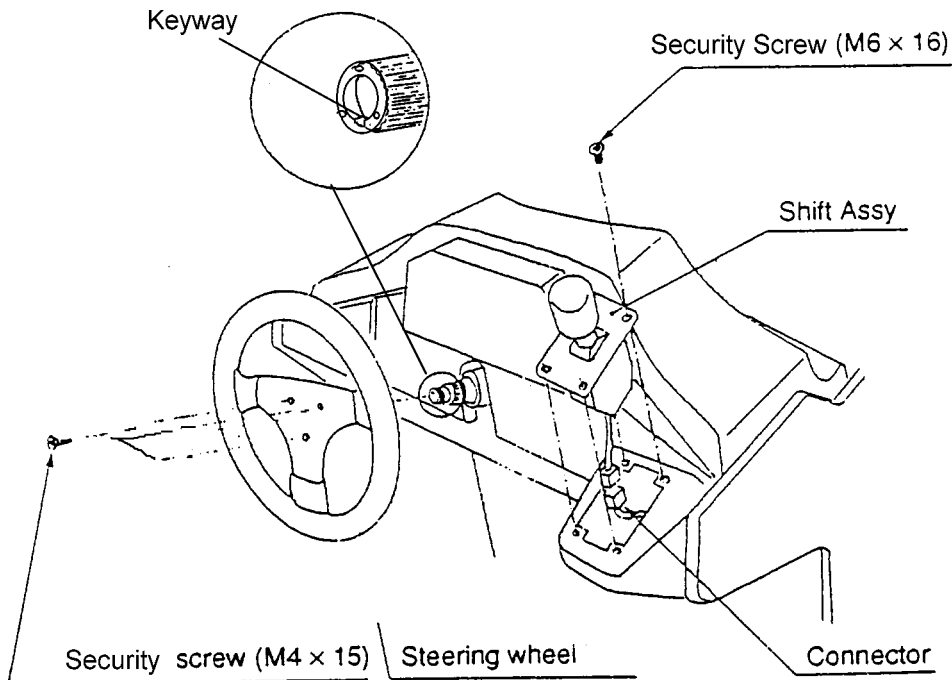

- b). Disconnect the connector.

- 2) Replacing the Microswitch
 - Remove the two pozi head screws (M3x16), and replace the switch. Ensure that the switch is refitted the correct way round.

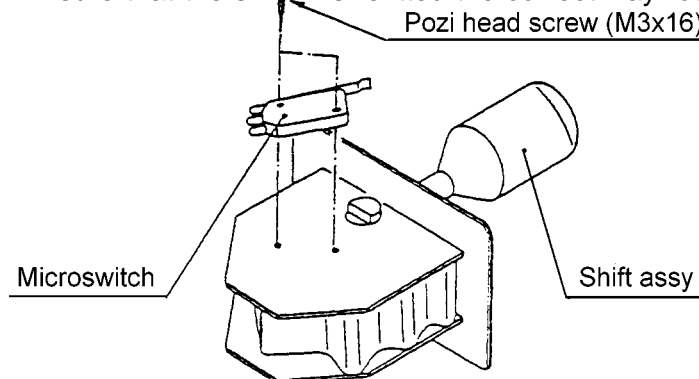

6-5-3. Replacing the Steering Drive PCB

- 1) Remove the shift assemble (Refer to section 6-5-2, "Shift Assy Maintenance".)
- 2) Remove the six security screws (M5x12), and slide the inner panel towards the steering wheel.
- 3) Remove the two security screws (M5x12) and the two security screws (M5x20), and remove the nose cover. (To remove the M5x20 security screws, push the seat assembly fully to the left and right. (Refer to section 6-7-1, "Removing the Rear Covers (L), (R)"))

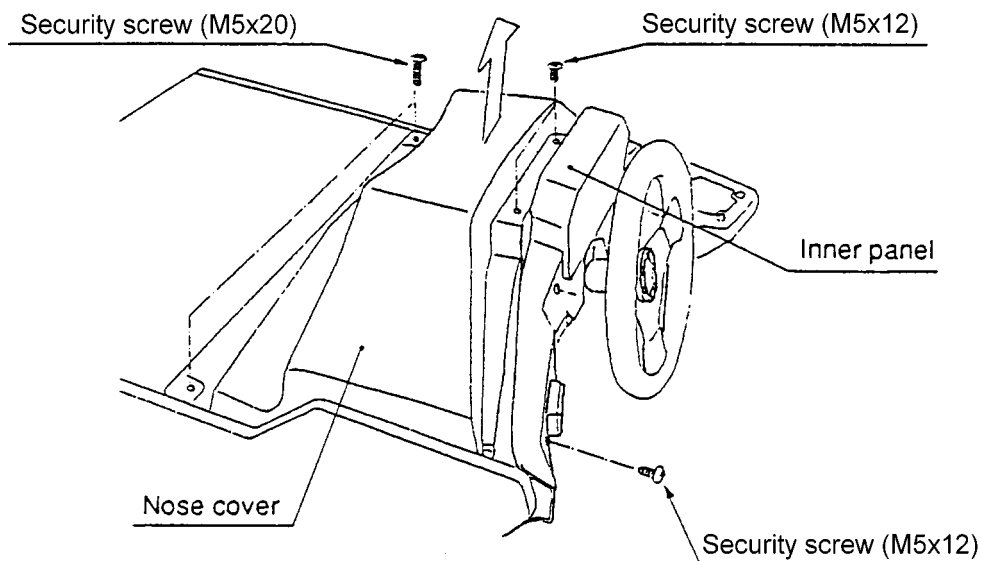

- 4) Remove the nose cover, then disconnect the four connectors on the PCB.
- 5) Remove the four nuts (M4), and remove the PCB complete with it's base.
- 6) Remove the four pozi head screws (M3x10), and remove the PCB from it's base.

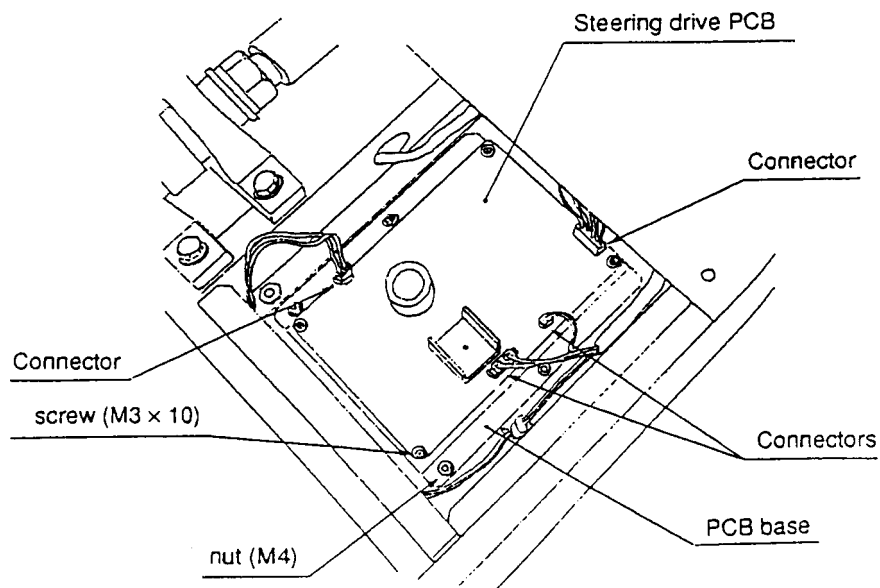

6-5-4. Replacing the Timing Belt

- 1) Remove the nose cover. (Refer to section 6-5-3, "Replacing the Steering Drive PCB.")
- 2) Remove the steering wheel. (Refer to section 6-5-1, "Replacing the steering wheel".)
- 3) Remove the lamp/switch assemblies from the view change and motion stop buttons, and remove the inner panel.
- 4) Remove the four hex head bolts (M6x16) and three security screws (M6x16), and remove the front panel.

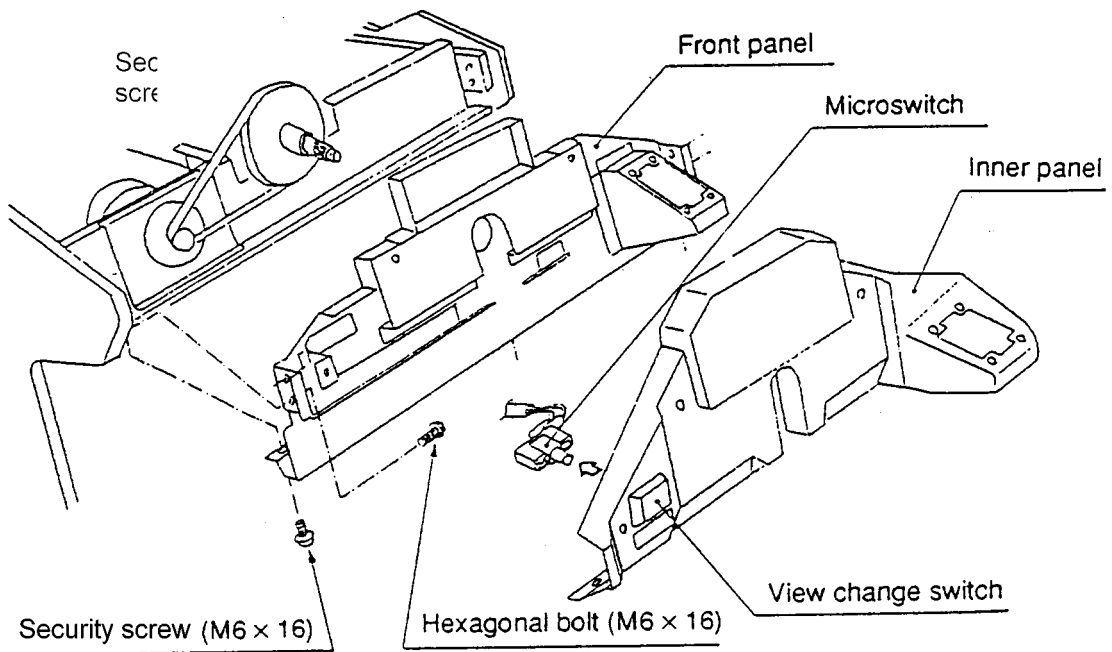

- 5) After removing the front panel, remove the locking nut (M6), and loosen the socket head bolt (M6x25) and four hex head bolts (M8x16). Slide the motor towards the steering and remove the timing belt.

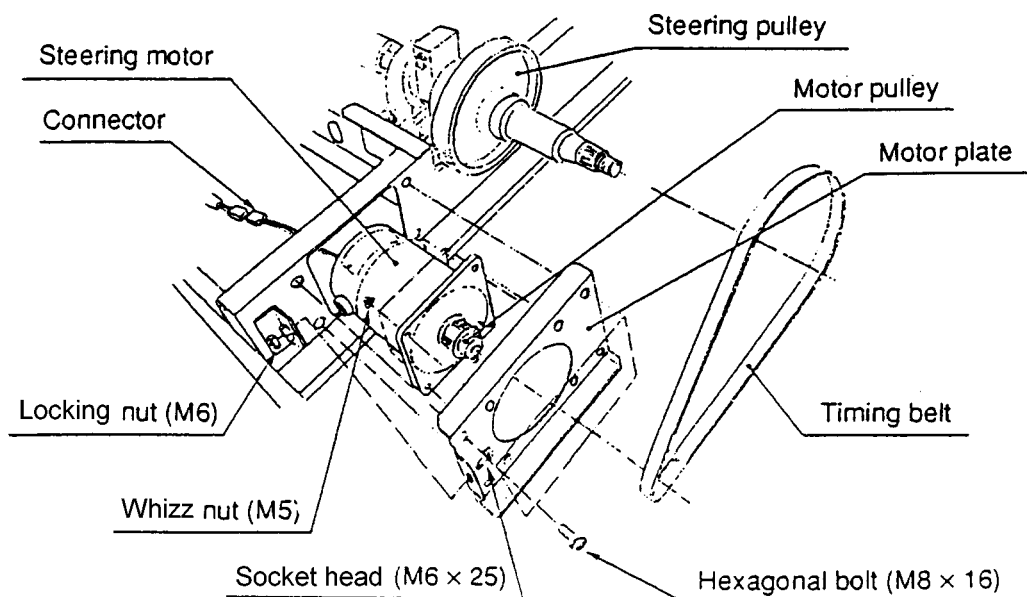

- 6) When replacing the timing belt, fit to the motor gear first. If the belt is forced, it could damage the belt or motor.
- 7) Set the belt tension using the socket head bolt (M6x25). The tension should be set so that the belt moves about 2-3mm when a force of 500g is applied to the belt between the pulleys. (The tension of the belt is 7-9kg.)

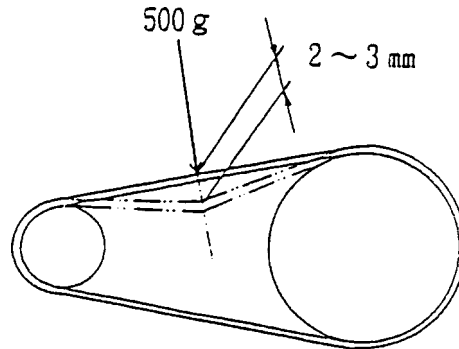

- 8) After setting the tension, tighten the locking nut (M6), to prevent the socket head bolt (M6x25) from moving, and the four hex head bolts (M8x16).

6-5-5. Replacing the Motor and Motor Brush

- 1) Replacing the Motor
 - a) Remove the timing belt. ([Refer to section 6-5-4](#), "Replacing the Timing Belt".)
 - b) Remove the locking nut (M6), the socket head bolt (M6x25), and the four hex head bolts (M8x16). Disconnect the connector and remove the motor.
 - c) Remove the four Whizz nuts (M5), and remove the motor from the mounting plate.
- 2) Replacing the Motor Brush
 - a) Remove the motor . (See steps a and b of replacing the motor.)
 - b) Remove the brush cover by sliding it towards the back of the motor. Replace the brush and cap.

Note: When replacing the brush, ensure that the brush slides in to the motor without binding.

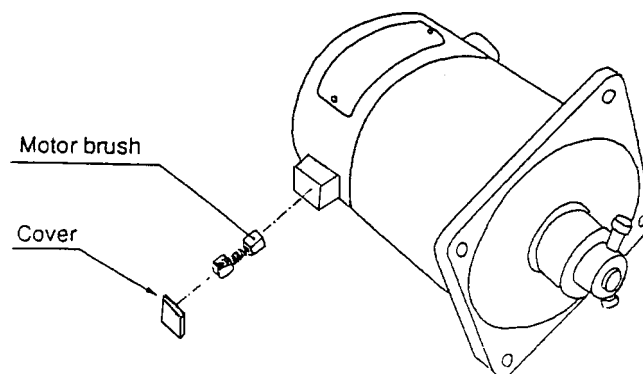

6-5-6 Replacing the Pulley

The pulley is retained to the motor shaft with a 'Taper-Lock' bush.

1) Removing the pulley

- a) Using a hex wrench, slacken the two grub screws a number of turns.
- b) Remove one of the grub screws and screw it into the release hole. Continue to tighten until the 'Taper-Bush' releases.
- c) Remove the pulley taking care not to lose the woodruff key.

2) Refitting the Pulley

- a) Fit the pulley onto the motor shaft until it is flush with the end of the shaft, ensuring that the woodruff key is fitted.
- b) Using a hex wrench, alternately tighten the two grub screws in the fix holes until tight.

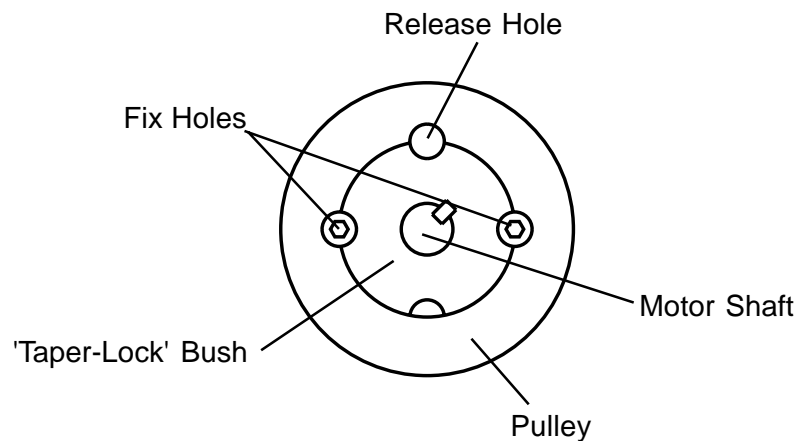

6-5-7. Replacing the Fuse

There is a fuse located below and to the left of the steering wheel. Use a flat blade screwdriver and turn the fuse cap anticlockwise to release the cap and fuse. Replace the fuse (5amp Slo-Blo)

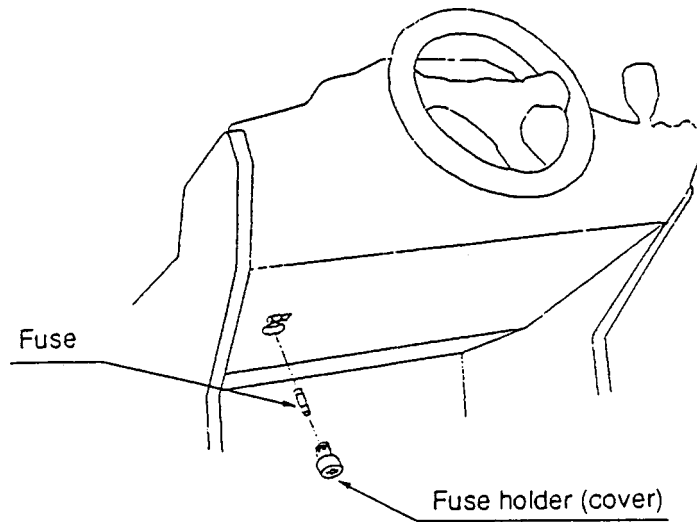

6-5-8. Replacing the Control Pot

- 1) Remove the six security screws (M5x20), and remove the rear cover of the upper base assembly.
- 2) Disconnect the connector located below the control pot.
- 3) Loosen the control shaft screw and remove the control and control stopper.
- 4) Remove the control from the control stopper.

NOTE: Replace only with a continuous rotation pot (Part No. X008-022)

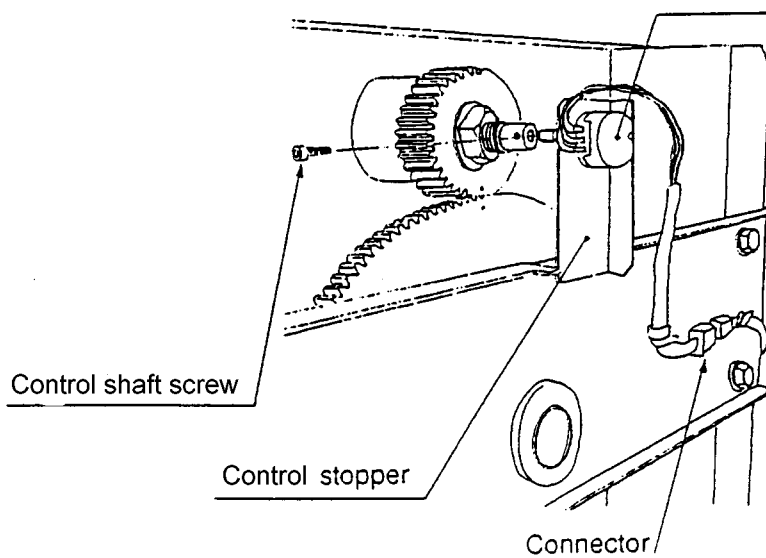

6-6. Replacing the Seat

6-6-1. Removing the Seat

- 1) Remove ten security screws (M5x10), and remove the headrest.
- 2) Loosen the security screws (M5x20) on seat side A, seat side B, and seat back A joints (six screws total). When doing this, take care to remove the screws completely.
- 3) Remove the ten security screws (M5x25), and remove seat side A, seat side B, and seat back A. When doing this, take care not to lose the washers for each screw.

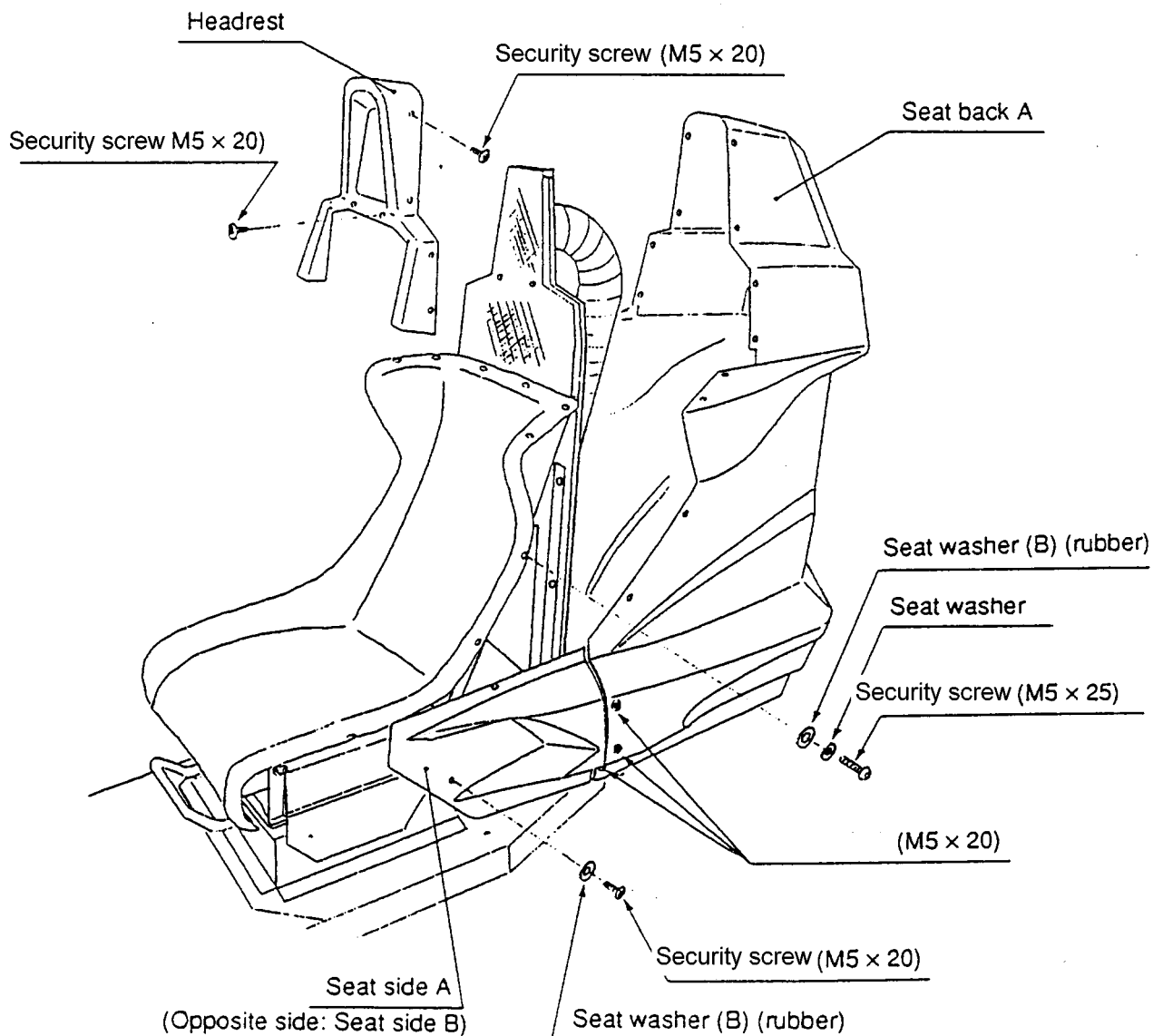

- 4) Remove the four pozi head screws (M5x25), and remove the speaker

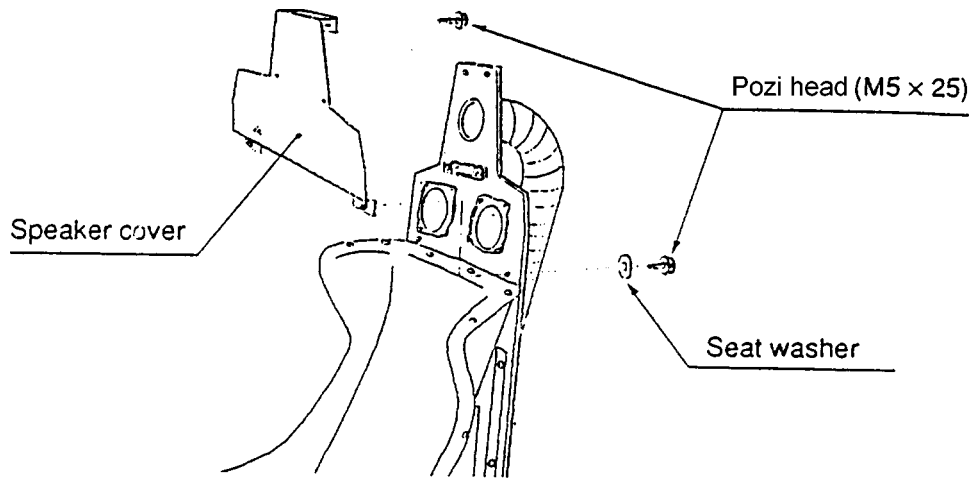

cover.

- 5) Remove the two pozi head screws (M5x25) and four security screws

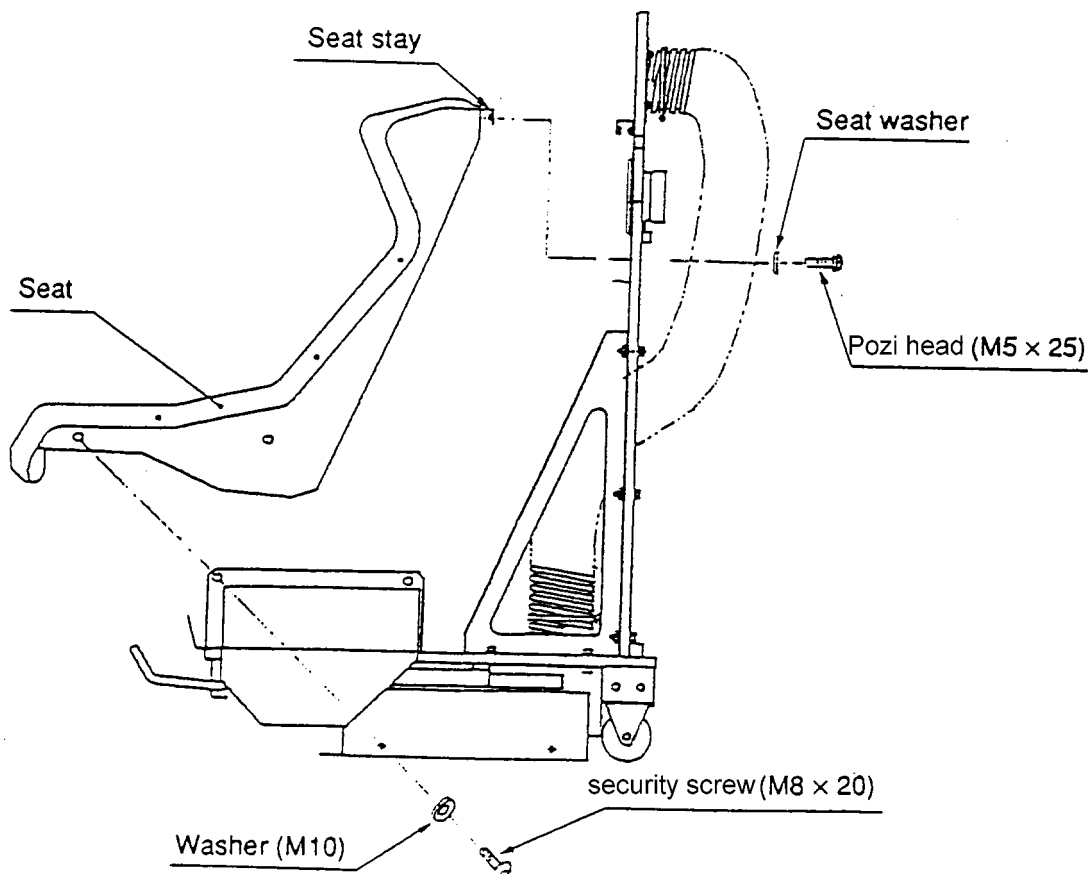

(M8x20), and remove the seat section.

- 6) Remove the two security screws (M5x25) and two Whizz nuts (M5) from the upper part of the removed seat section, and remove the seat stay from the seat.
- 7) When doing this, take care not to lose the washers.

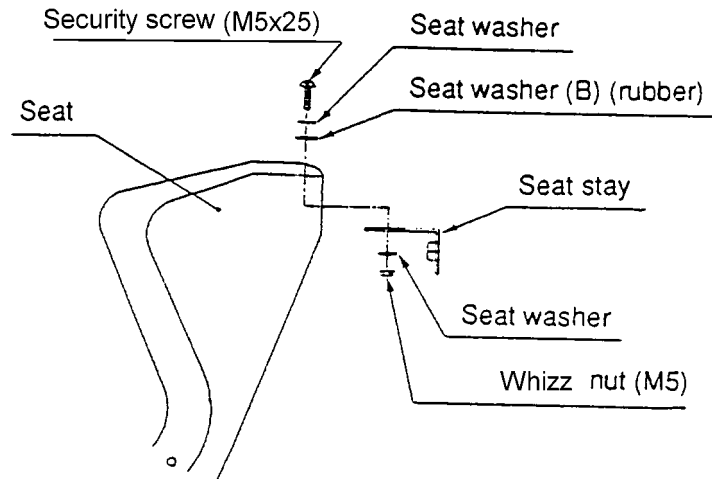

6-6-2. Installing the Seat

- 1) Temporarily fasten the seat stay to the seat ([Refer to 6-6-1, step 6](#)).
- 2) Install the seat section to the seat.
- 3) Temporarily fasten the seat to the seat holder, and the seat stay to the rear board.
- 4) Secure the seat making sure that the seat line is parallel with the seat holder.
- 5) Tighten all of the screws in the seat and seat stay.
- 6) Install the speaker cover.
- 7) Install seat side A, seat side B, seat back A, and the headrest, following the reverse procedure of [section 6-6-1 steps 1-3](#).

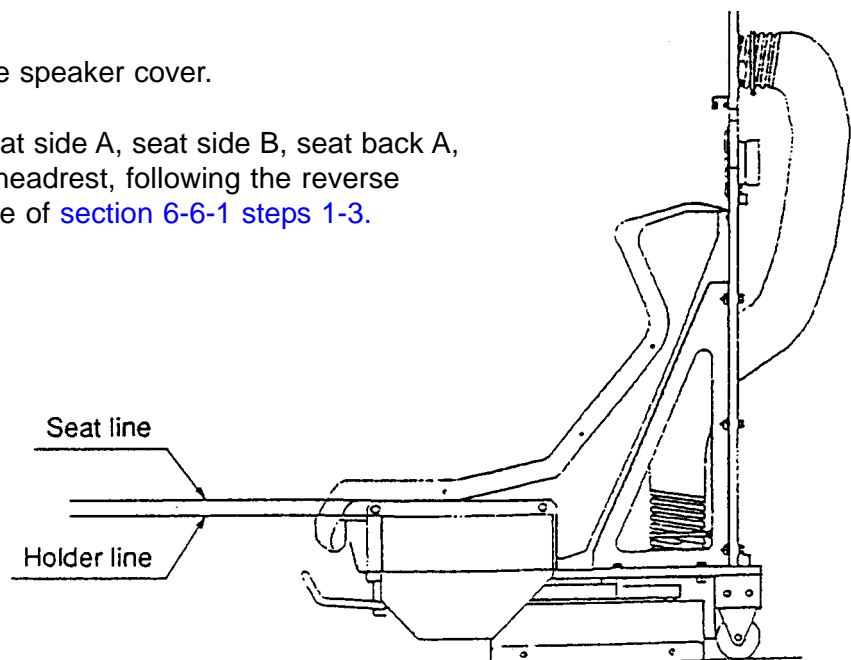

6-7. Under Base Assembly

DANGER: The drum drive PCB (see section 6-7-2, "Names of Under Base Parts") has areas of high voltage and high temperature even after the power has been turned OFF. Take care not to touch the PCB to avoid receiving electric shocks or burns.

DANGER: Ensure that the power is turned OFF before commencing work.

WARNING: This work involves moving the seat assembly from left to right in order to remove screws. Take care not to trap or injure the other person when performing this work.

6-7-1. Removing the Rear Covers (L), (R)

Removing the Rear Cover (L)

- 1) Remove the rear guard fence.
- 2) Turn the steering wheel all the way to the right, and move the cabinet by hand so that the rear cover (L) is easier to remove.
- 3) Remove the security screws (M5x20), and remove the edge guards and rubber skirts.
- 4) Remove the nine security screws (M5x12) and two security screws (M8x20), then remove the rear cover (L)

Removing the Rear Cover (R)

- 1) Turn the steering wheel all the way to the left and move the cabinet to the left by hand so that the rear cover (R) is easier to remove.
- 2) Remove the rear cover (R) in the same way as the rear cover (L) as above.

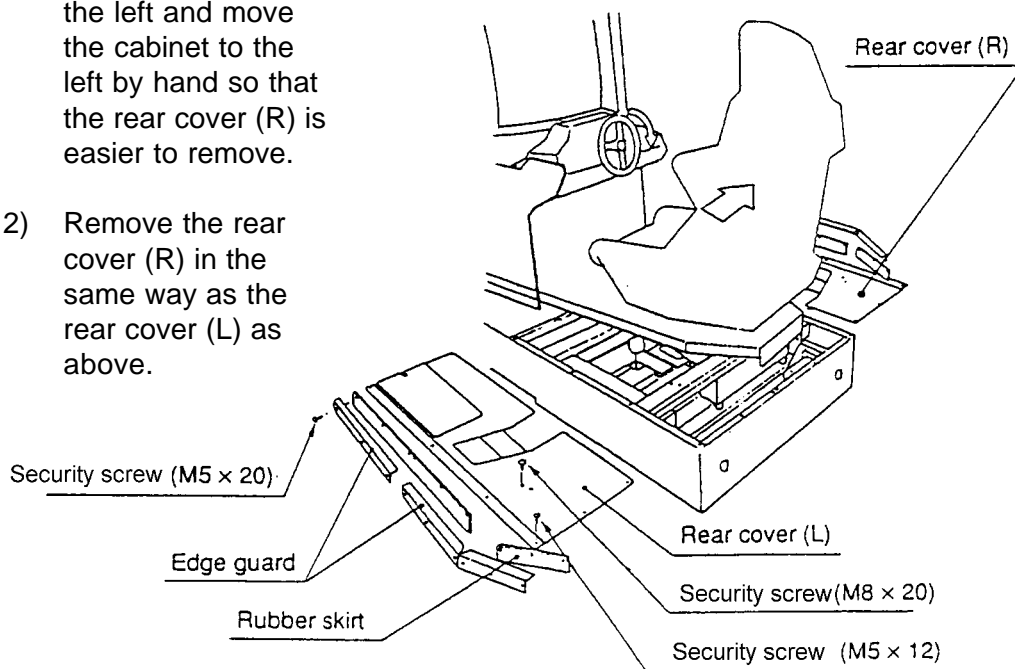

6-7-2. Names of Under Base Parts

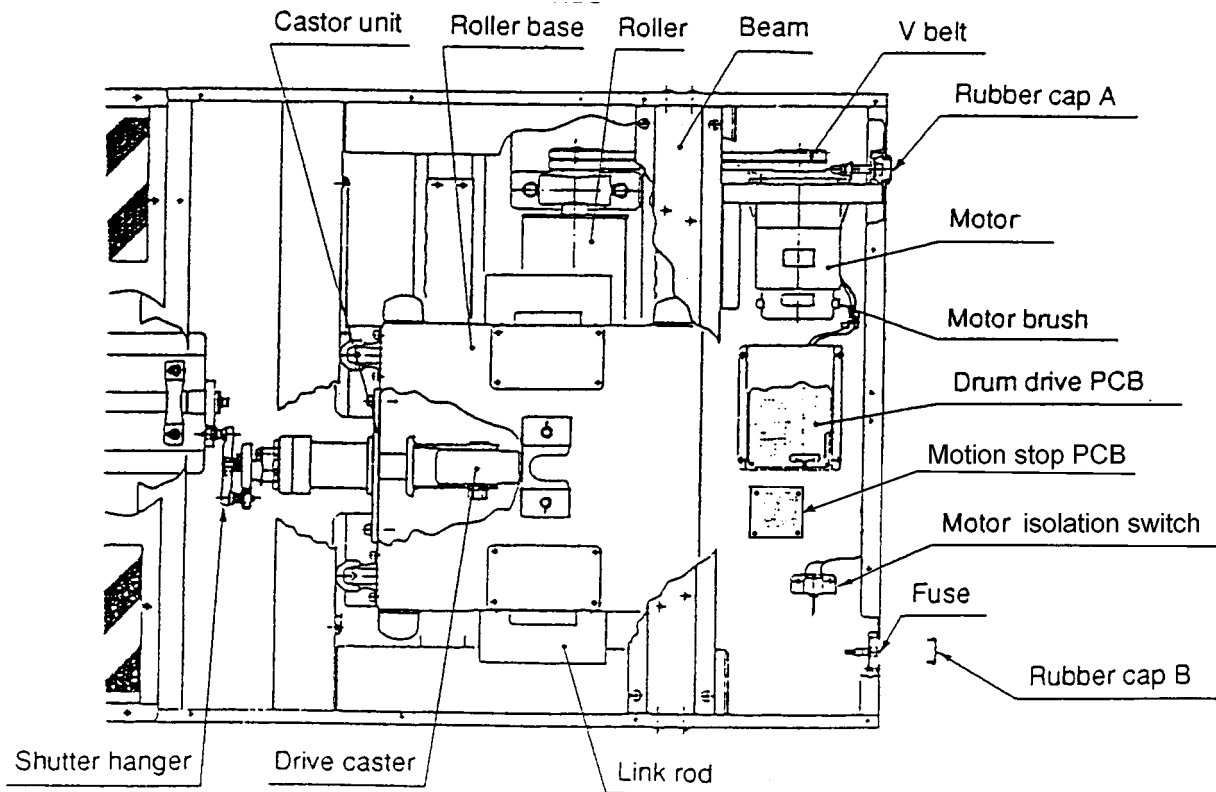

6-7-3. Replacing the Drive Castor

NOTE: *When replacing the castor, it is recommended that two people perform the work and safety gloves are worn.*

1) Removing the Castor Unit.

- a) Remove the nut (M10), and remove the link rod and link arm.
- b) Remove the Hex head bolt (M8x20), and remove the nut locking bracket from the link arm.
- c) Use the nut locking bracket and turn the hexagonal nut until it touches the housing.

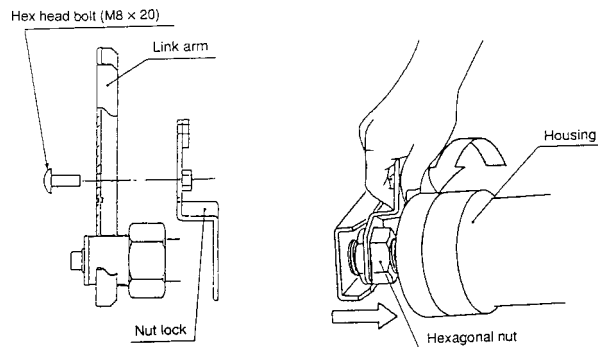
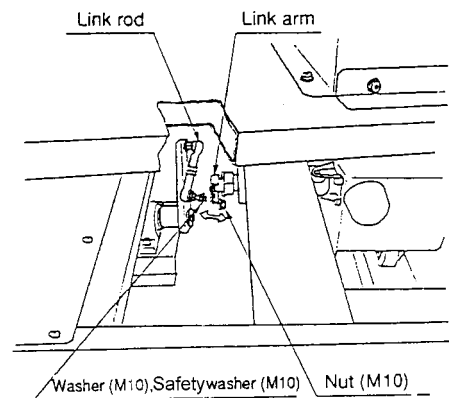

- d) Loosen the four hex head bolts (M10x40) that hold the housing to the main housing.
- e) The housing is fixed using keyholes. Lift the housing up and then pull it forward to remove the castor unit. If there is difficulty in removing the unit, remove the top two bolts.
- f) Remove the nut (M20), pull out the shaft and replace the drive castor.
- g) When replacing the drive castor, ensure that the shaft key aligns with the keyway in the housing.
- h) Tighten the nut (M20) so that there is no play between the drive castor and housing. Take care not to tighten the nut too tight, or the castor will not turn freely.
- (i) Re-tighten the four hex head bolts (M10x40) to a torque of 70 ft/lb

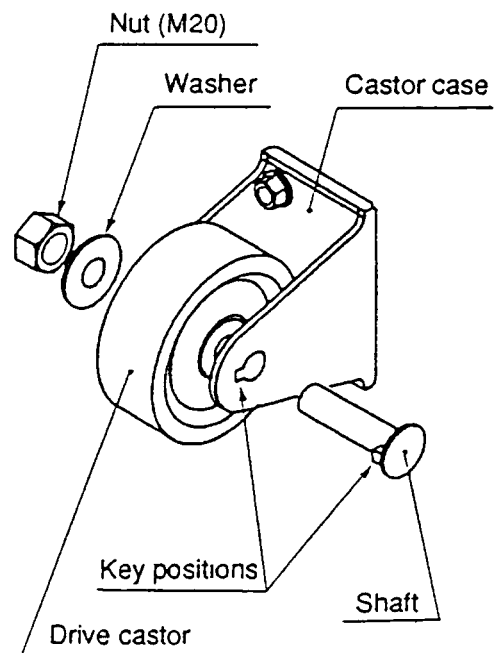
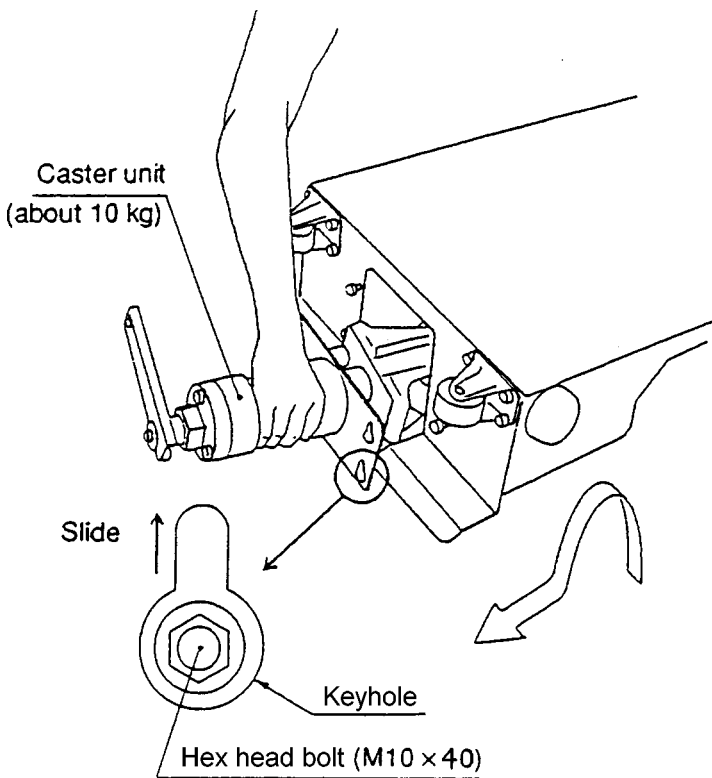
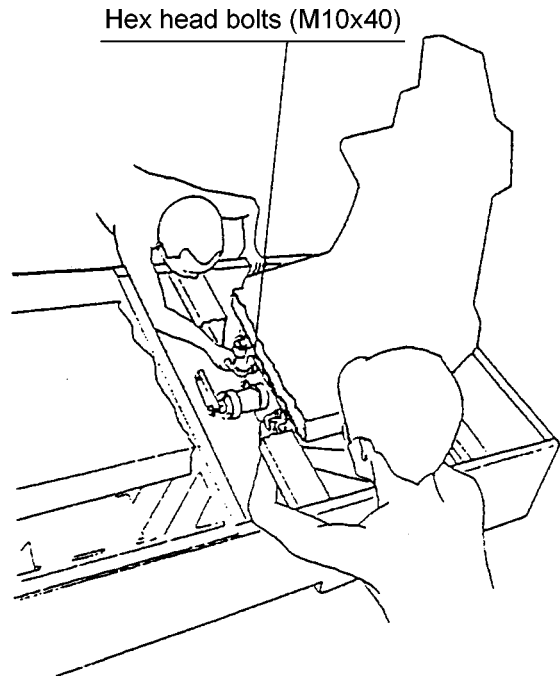

2) Notes on Installing the Castor Unit

- a) Install the castor unit in the roller base, and tighten the four hex head bolts (M10x30).
- b) Use the nut locking bracket to turn the nut towards the link arm and set the spacing between the nut and housing as shown in fig A. This space should be set so that the nut just grips the spacer section of the locking bracket to the housing as shown in fig B.
- c) Refit the nut locking bracket using the hex head bolt (M8x20).
- d) Connect the link rod and link arm. Ensure this is done as shown in fig C. *Note The steering will not work properly if the direction is incorrect.*
- e) Refit the rear covers (L) and (R), and rear safety fence.

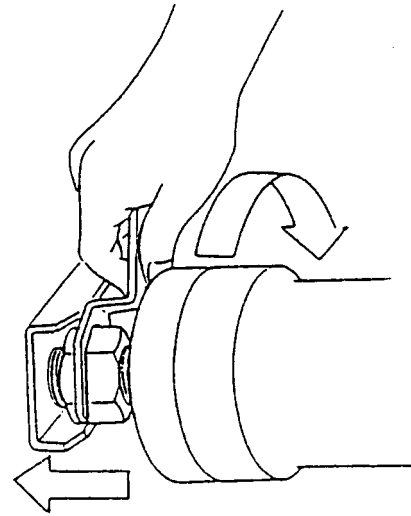

Figure A

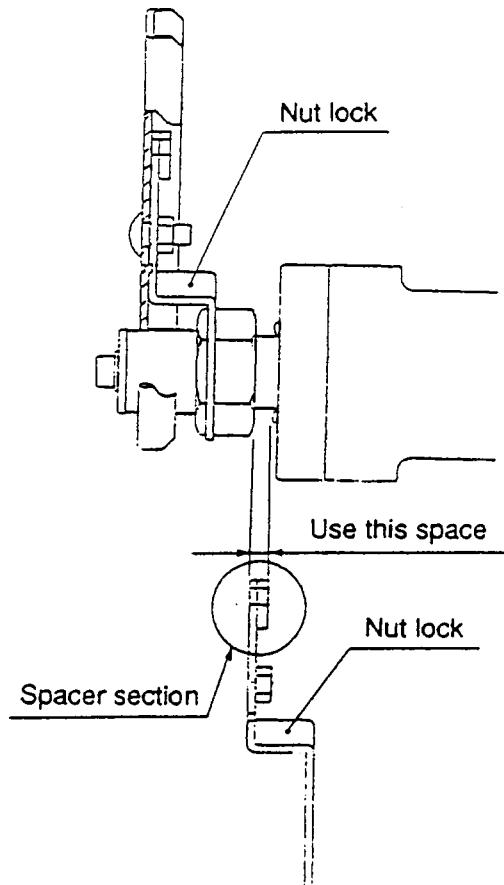

Figure B

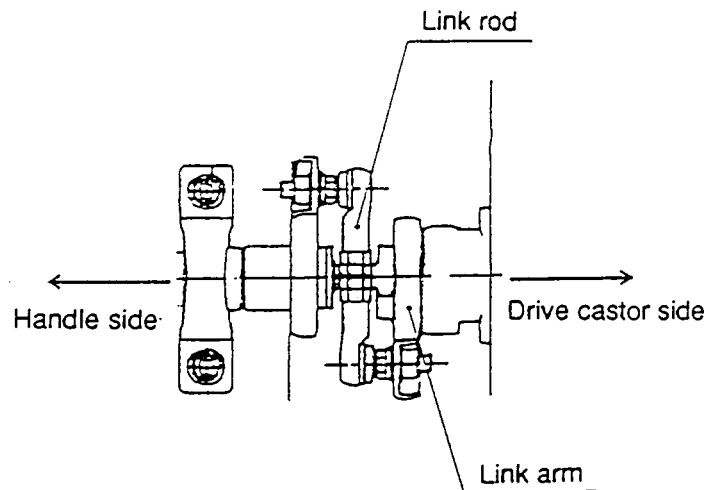
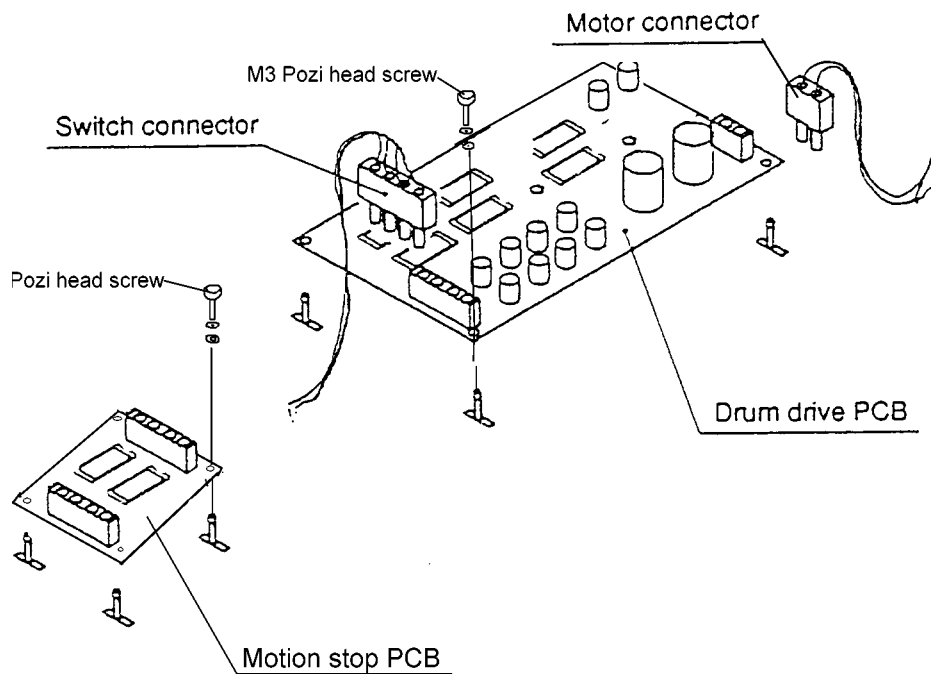

Figure C

6-7-4. Replacing the Drum Drive PCB and Motion Stop PCB

- 1) Remove the rear cover (R). (Refer to section 6-7-1, "Removing the Rear Cover.")
- 2) Disconnect all the connectors
- 3) Remove the Pozi head screws (M3X10) and washers, and remove the PCB.



6-7-5. Replacing the V Belts

1) Removing the V Belts

- a) Remove the rear covers (L), (R). (Refer to section 6-7-1, "Removing the Rear Covers".)
- b) Remove the four bolts (M8x20) and the four security screws (M8x40), then remove the beam. See section 6-7-2, "Names of Under Base Parts" page 37.)
- c) Loosen the four hex head bolts (M8x20).
- d) Remove the locking nut (M10).
- e) Remove rubber cap A, and remove the tension bolt (M10x60) and washer.
- f) Push the motor to the right as shown, and remove the two V belts.

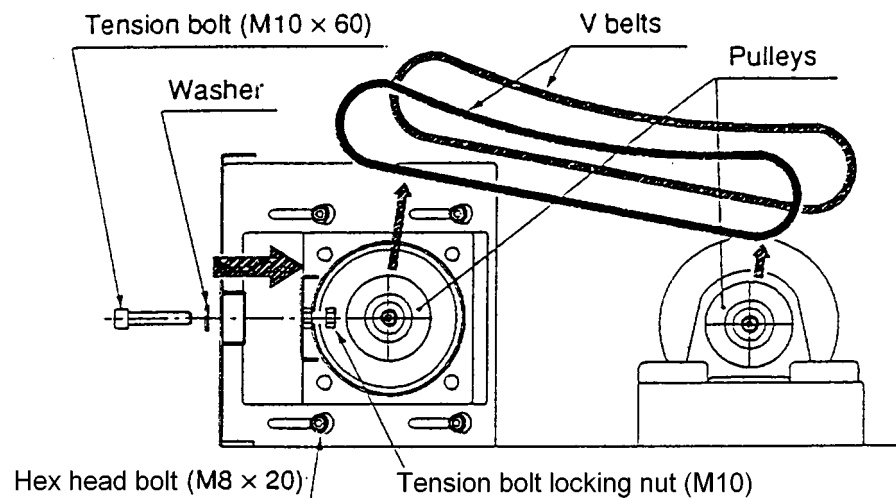

2) Installing the V Belts

- a) Place the two V belts on the pulleys.
- b) Attach the tension bolt (M10x60) and washer.
- c) Adjust the tension of the V belts by tightening the tension bolt. The belts should be adjusted so that they have about 5-6mm of slack when the centre of the belts are depressed with a force of 2kg. Tighten the locking nut (M10). (The tension in the belt is 19-21kg.)
- d) Refit the beam, and tighten the four bolts (M8x20), and four security screws (M8x40).
- e) Replace rubber cap A.

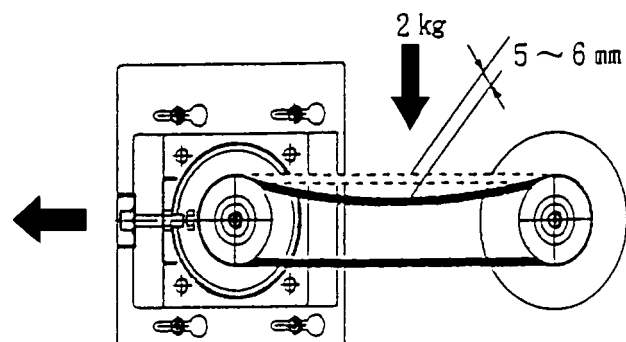

6-7-6. Replacing the Motor and Motor Brushes.

- 1) Replacing the Motor Brush.
 - a) Remove the rear cover (Refer to section 6-7-1, "Removing the Rear Covers".)
 - b) Remove the pozi head screws from the brush covers (located either side of the motor), and remove the covers
 - c) Replace the two brushes. (Ensure that the brushes slide freely into the motor when replacing.)
- 2) Replacing the Motor
 - a) Remove the two V belts (Refer to section 6-7-5, "Removing the V Belts".)
 - b) Disconnect the motor connector.
 - c) Remove the motor with the slider bracket attached.
 - d) Remove the four nuts (M10), and remove the motor from the slider bracket.
 - e) When installing the motor, adjust the V belts as described in section 6-7-5, "Installing the V Belts".

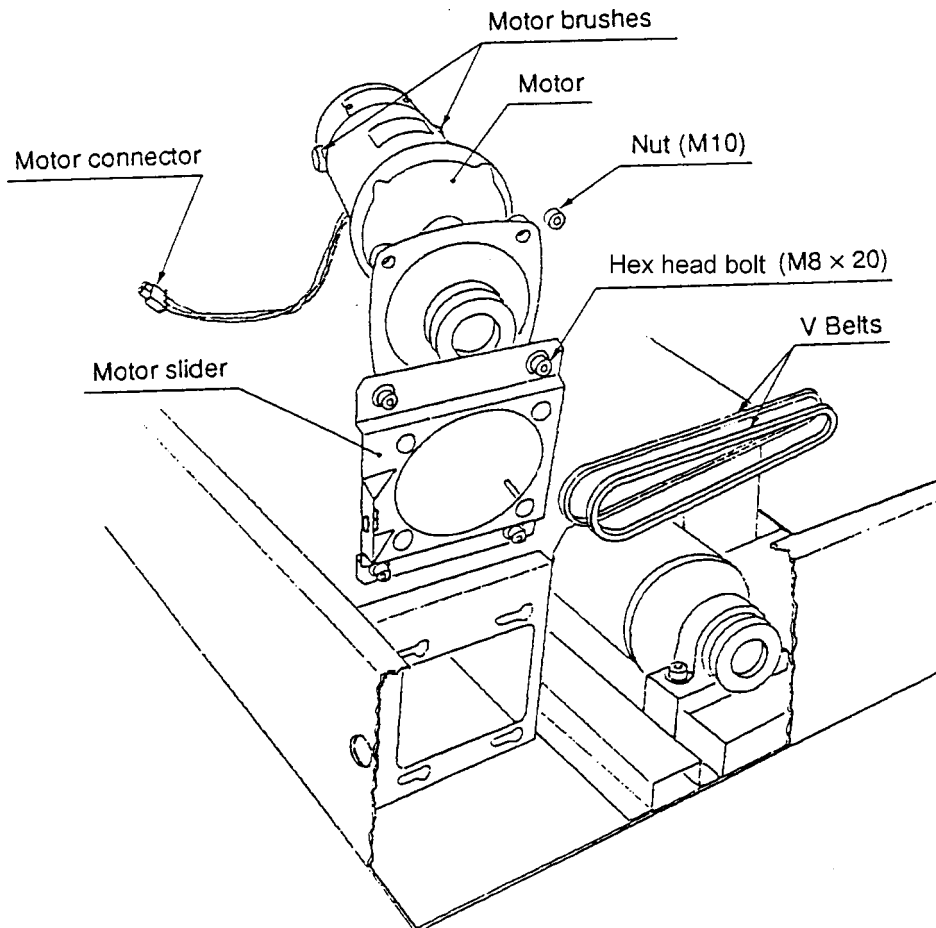

6-7-7. Replacing the Motor Fuse

The fuse is located as shown in section 6-7-2, page 37.

- 1) Remove the rubber cap B.
- 2) Turn the fuse cap anticlockwise half a turn, and remove the cap and fuse.
- 3) Replace the fuse (5A, Slo-Blb).

6-8. AB Pedal Assembly

6-8-1. Removing the AB Pedal Assembly

- 1) Remove the four security screws (M6x20), and withdraw the assembly forward.
- 2) Disconnect the connector, and remove the assembly.

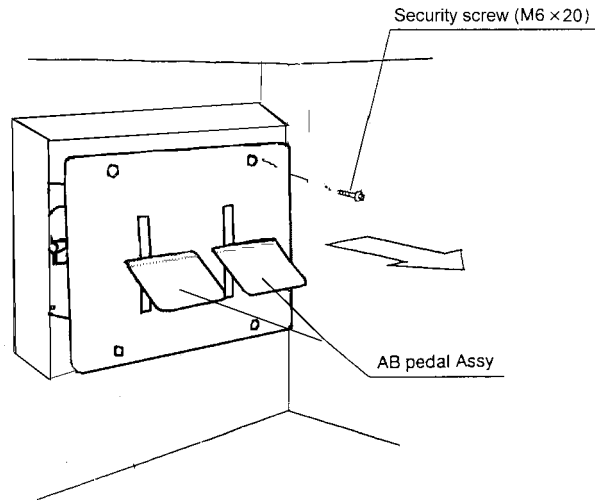

6-8-2. Replacing the Control Pots

- 1) Loosen the quadrant gear clamp screw, and remove the quadrant gear.
- 2) Loosen the gear grub screw, and remove the gear.
- 3) Replace the control pot.

Note: When replacing the control pot

- a. *Ensure that the potentiometer locating tag is engaged in the mounting plate hole.*
- b. *Turn the potentiometer shaft almost fully clockwise before engaging the quadrant gear.*

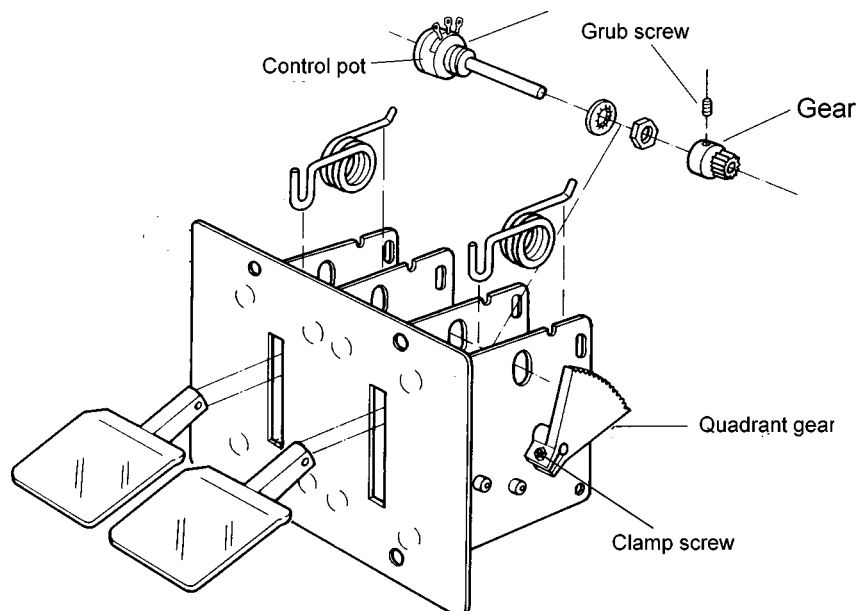

6-9. Handling Drive Castor Wear

This machine uses a moveable mechanism controlled by the pressing of a drive castor against the metal roller. During the playing of the game, this castor gradually wears due to the constant friction with the roller.

When the drive castor wears sufficiently, the pressure becomes poor, and the seat assembly is no longer driven left and right and can be pushed easily sideways by hand. This will take about a year to occur. (This is assuming that the game is played 7.5 hours per day. This period will vary depending on how often and for how long the game is played.

6-9-1. Checking Drive Castor Wear

The drive castor should be checked, when the machine displays the following symptoms.

- Game play is possible on the screen, but the seat assembly does not move.
- When the steering wheel is turned to the left or right, the seat assembly movement is slow.

NOTE: First check that the motor is working.

If the motor is not working, ensure that the motor switch in the under base is turned ON.

If the motor switch is ON but the motor is not working, there is a motor problem, and should be checked as described in section 7, "Troubleshooting".

Method of Checking

- 1) Ensure that the power to the machine is turned OFF.
- 2) Remove the fence, and rear cover (L) or (R). (Refer to section 6-7-1, "Removing the Rear Covers (L), (R)" on page 36.)
- 3) Look at the drive castor in the roller base. If the drive castor moves left and right when the steering wheel is turned, there is no problem with the steering linkage, and the problem is the drive castor worn out.

6-9-2. Action When the Drive Castor is Worn Out

If the drive castor is worn out, discontinue use of the machine until the following has been carried out.

- 1) Turn the main power to the machine OFF.
- 2) Remove the fence.
- 3) Remove the rear cover (L), (Refer to section 6-7-1, "Removing the Rear Covers".)
- 4) Turn the motor switch in the under base OFF.
- 5) Refit rear cover (L).
- 6) Refit and securely fasten the seat assembly shipping brackets that were removed when the machine was first installed.
- 7) Refit the fence.
- 8) After the above has been carried out, turn the main power to the machine ON.
- 9) After a new drive castor has been fitted, ensure that the game is re-initialized before the game is played. (Refer to section 6-7-1, "Removing the Rear Covers", 6-7-3, "Replacing the Drive Castor", and 5-5, "Adjustments When Replacing Parts".)
- 10) After fitting the new drive castor, remember to turn the motor switch ON.

7. TROUBLESHOOTING

DANGER: To avoid injury, always turn the main power OFF, before carrying out any checks or adjustments.

Check the following whenever there is a problem with the machine.

- 1) The machine requires a mains supply of 220-240volt AC. If there are several high current devices (air conditioners, large rides or other large machines etc.) connected to the same power supply, the power supply may fluctuate due to power surges, and cause game malfunction.
Each machine requires a maximum of 8amps, Ensure an adequate power supply to prevent an overload and possible fire risk.
 - 2) If the machine fails to work even though the power is ON, try turning the power off and back on. If the machine still fails to work, check the mains in fuse.
 - 3) If the seat assembly does not move even though game play is possible on the screen, check that the seat shipping brackets have been removed, the motor switch in the under base is turned on, and the condition of the drive castor. Check the drive castor according to [section 6-9](#), "Handling the Drive Castor Wear" (page 44).
 - 4) The game will not operate correctly if it has not been initialized after replacing the game PCB, ROM, or control pots. Adjustment should be performed according to [section 5-5](#), "Adjustment After Replacing Parts" (page 21).
 - 5) Check all wiring for loose connections.
 - 6) Dirt and dust on the game PCB, steering PCB, drum motor drive PCB, or monitor PCB, could cause a malfunction, so all PCB's should be kept clean.
 - 7) When checking electrical problems, refer to the wiring diagrams, and make sure that the connectors and wire colours are correct.
- If none of the items 1-7 above seem to be the cause of the problem, or the problem is not cured, contact your dealer.
 - Repairs to the PCB should be carried out by your dealer. **NEVER** perform a continuity check on the PCB with a test meter, as the internal voltage of the meter could cause damage to PCB components.
 - When sending a part for repair, clearly describe the problem and ensure that the part is properly packed in a sturdy container to prevent damage in transit.

8. PARTS

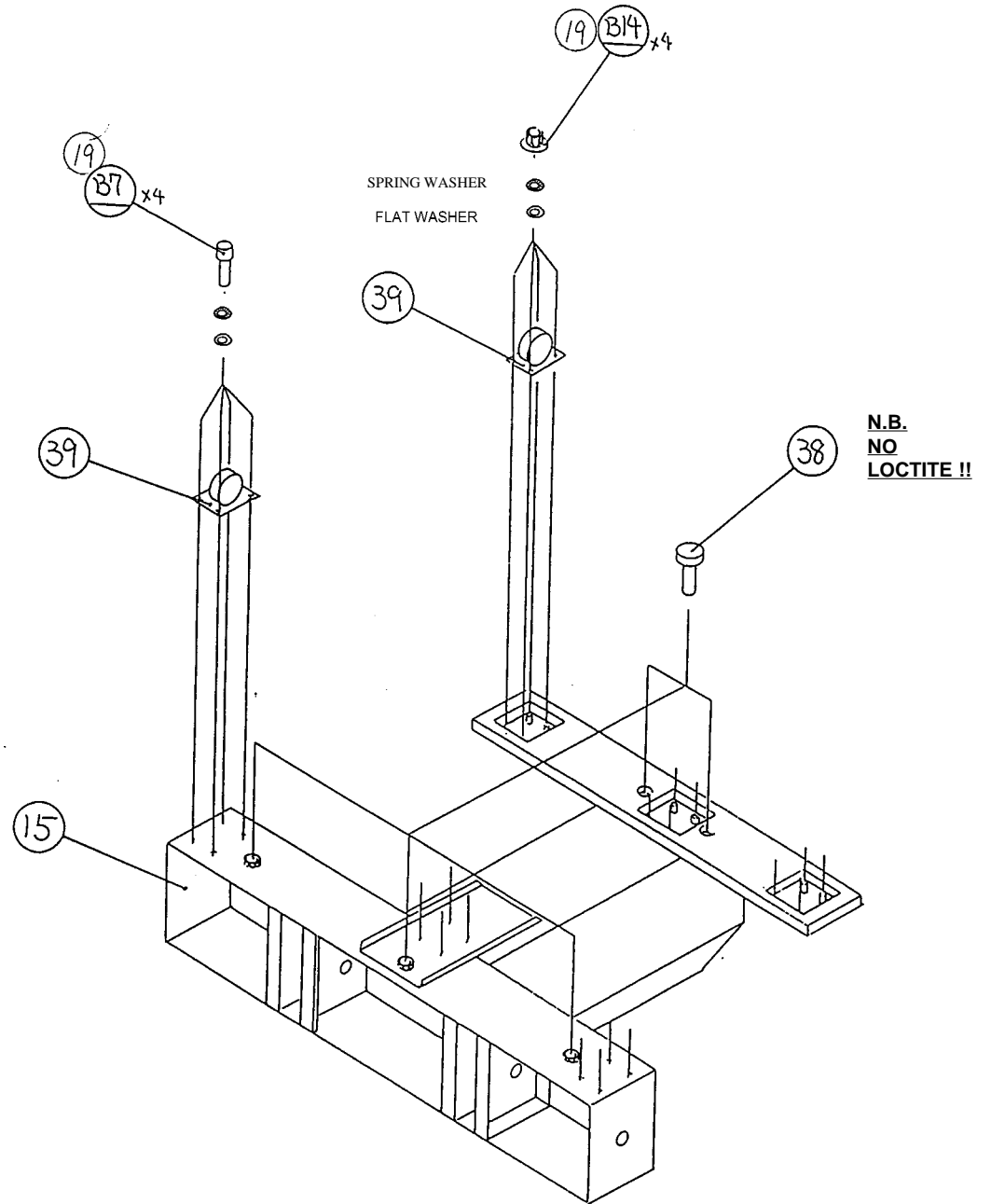

ITEM	DESCRIPTION	PART No.
B14	M6 FULL NUT	27000021
B7	M6x20 HEX HEAD SET SCREW - BZP	88300700
	M6 FLAT WASHER H/DUTY -BZP	88300702
	M6 SPRING WASHER TYPE B - BZP	28000034
39	SWIVEL CASTOR - 63mm	59000002
38	ADJUSTABLE FOOT M20x125 W/LOCK NUT	25000008
15	TOWER PLINTH	45000300
19	LOCTITE 242	95000009

ITEM	DESCRIPTION	PART No.	QNTY
B12	M8x25 SECURITY BUTTON HEAD - SUS	26300042	20
	M8 FLAT WASHER - SUS	28000030	20
	M8 SPRING WASHER TYPE B - SUS	28000017	20
B9	M8x25 HEX HEAD SET SCREW - BZP	26300050	8
	M8 FLAT WASHER H/DUTY - BZP	88300702	8
	M8 SPRING WASHER TYPE B - BZP	28000027	8
B3	M5x12 PZ PAN HEAD SCREW - BZP	26500432	4
	M5 FLAT WASHER H/DUTY - BZP	88300432	4
	M5 SPRING WASHER TYPE B - BZP	28000026	4
21	COIN TOWER INTERNAL SUPPORT BRACKET	45000306	1
19	LOCTITE 242	95000009	
17	TOWER SIDE SUPPORT RHS	45000302	1
16	TOWER SIDE SUPPORT LHS	45000301	1
12	PCB STOP BRACKET	45000299	1
11	SHORTY BUSHING	39000051	12
10	EXTRUDED GROMMETING	39000807	
1	TOWER CENTRE SECTION	45000288	1

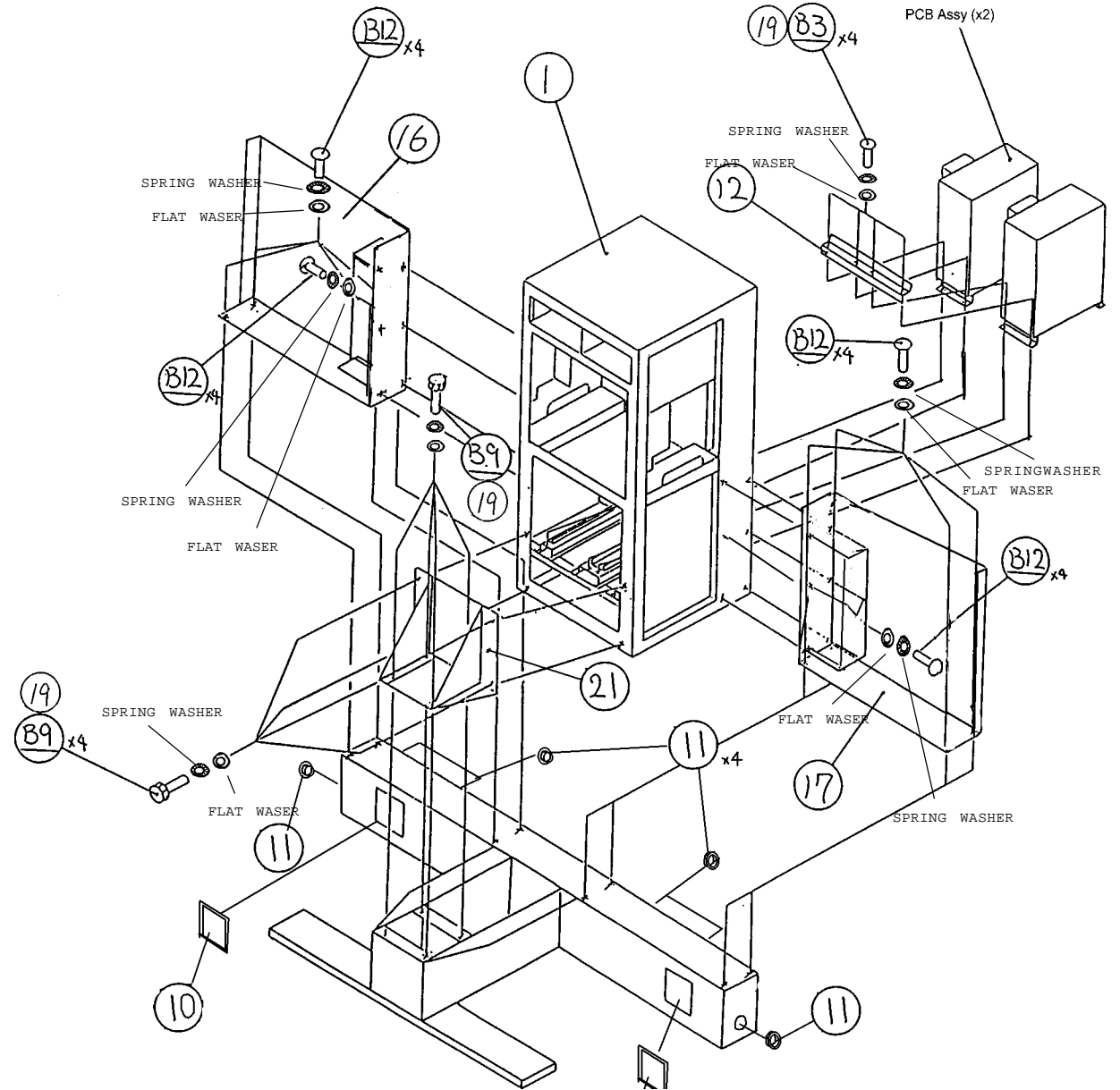

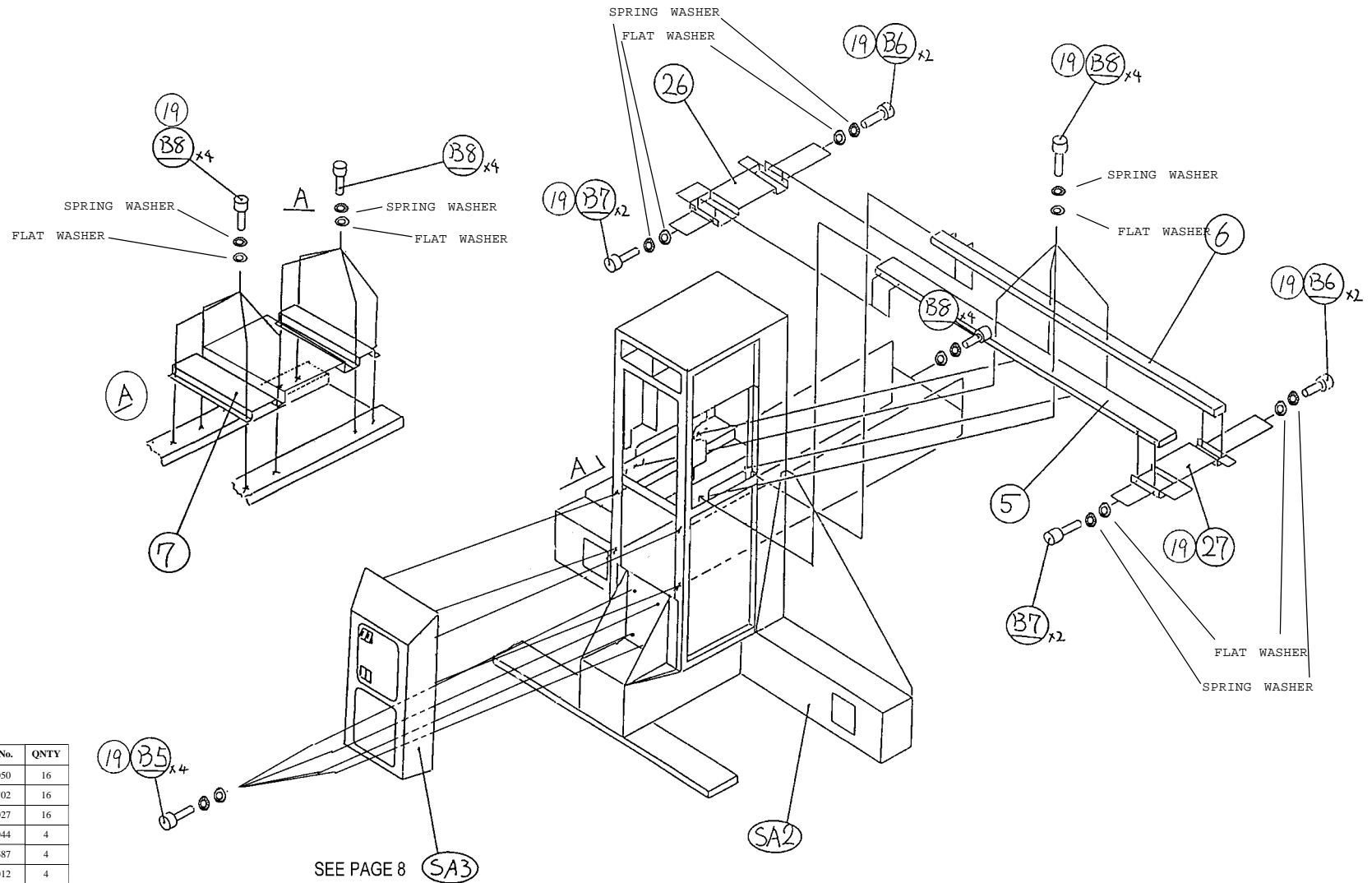

ITEM	DESCRIPTION	PART No.	QNTY
B8	M8x25 HEX HEAD SET SCREW - BZP	26300050	16
	M8 FLAT WASHER H/DUTY - BZP	88300702	16
	M8 SPRING WASHER TYPE B - BZP	28000027	16
B7	M6x16 SECURITY BUTTON HEAD SCREW - SUS	26300044	4
	M6 FLAT WASHER - SUS	88300687	4
	M6 SPRING WASHER TYPE B - SUS	28000012	4
B6	M4x12 SECURITY BUTTON HEAD SCREW - SUS	26300041	4
	M4 FLAT WASHER - SUS	88300687	4
	M4 SPRING WASHER TYPE B - SUS	28000016	4
B5	M10x20 HEX HEAD SET SCREW - BZP	26500409	4
	M10 FLAT WASHER H/DUTY - BZP	88300794	4
	M10 SPRING WASHER TYPE B - BZP	28000023	4
27	MONITOR CABINET CLAMP BRACKET - RHS	45000312	1
26	MONITOR CABINET CLAMP BRACKET - LHS	45000311	1
19	LOCTITE 242	95000009	
7	MONITOR SUPPORT RAIL INTERNAL CLAMP	45000294	1
6	MONITOR SUPPORT RAIL - REAR	45000293	1
5	MONITOR SUPPORT RAIL - FRONT	45000292	1
2	COIN TOWER ASSEMBLY	45000289	1

ITEM	DESCRIPTION	PART No.	QNTY
E3	SES LAMP HOLDER	64800003	4
E2	240v 25w SES SILVERED LAMP	64000083	4
B11	3.2x9.5 RIVET	23000010	4
B5	M5x12 SECURITY BUTTON HEAD SCREW - SUS	26300045	8
B3	M5x12 HEX HEAD SET SCREW - BZP	26500432	4
	M5 FLAT WASHER H/DUTY - BZP	88300432	4
	M5 SPRING WASHER TYPE B - BZP	28000026	4
B2	No.4 x 1/2" PZ PAN HEAD SCREW - BZP	26100070	8
47	COIN TOWER SAFETY DECAL	40000205	2
46	YELLOW CAR DECAL	40000201	1
45	GREEN CAR DECAL	40000202	1
44	BLUE CAR DECAL	40000203	1
43	RED CAR DECAL	40000204	1
40	FLUORESCENT TUBE ASSEMBLY		1
	FLUORESCENT ASSY WOOD	37100041	1
	12" TWIN LIGHTING TRAY	64500038	1
	12" 8W FLUORESCENT TUBE	64500008	2
39	M4 WING NUT - BZP	27000129	5
29	SERIAL NUMBER PLATE	-----	1
28	CE COMPLIANCE LABEL	-----	1
20	TOWER PLINTH FRONT CENTRE CLOSING PLATE	45000305	1
19	LOCTITE 242	95000009	
14	CENTRE ACRYLIC	44000005	1
11	CENTRE ACRYLIC TOP RETAINING BRACKET	45000298	1
10	RACE START LAMP MNTG BRKT - LHS	45000296	1
9	RACE START LAMP MNTG BRKT - RHS	45000297	1

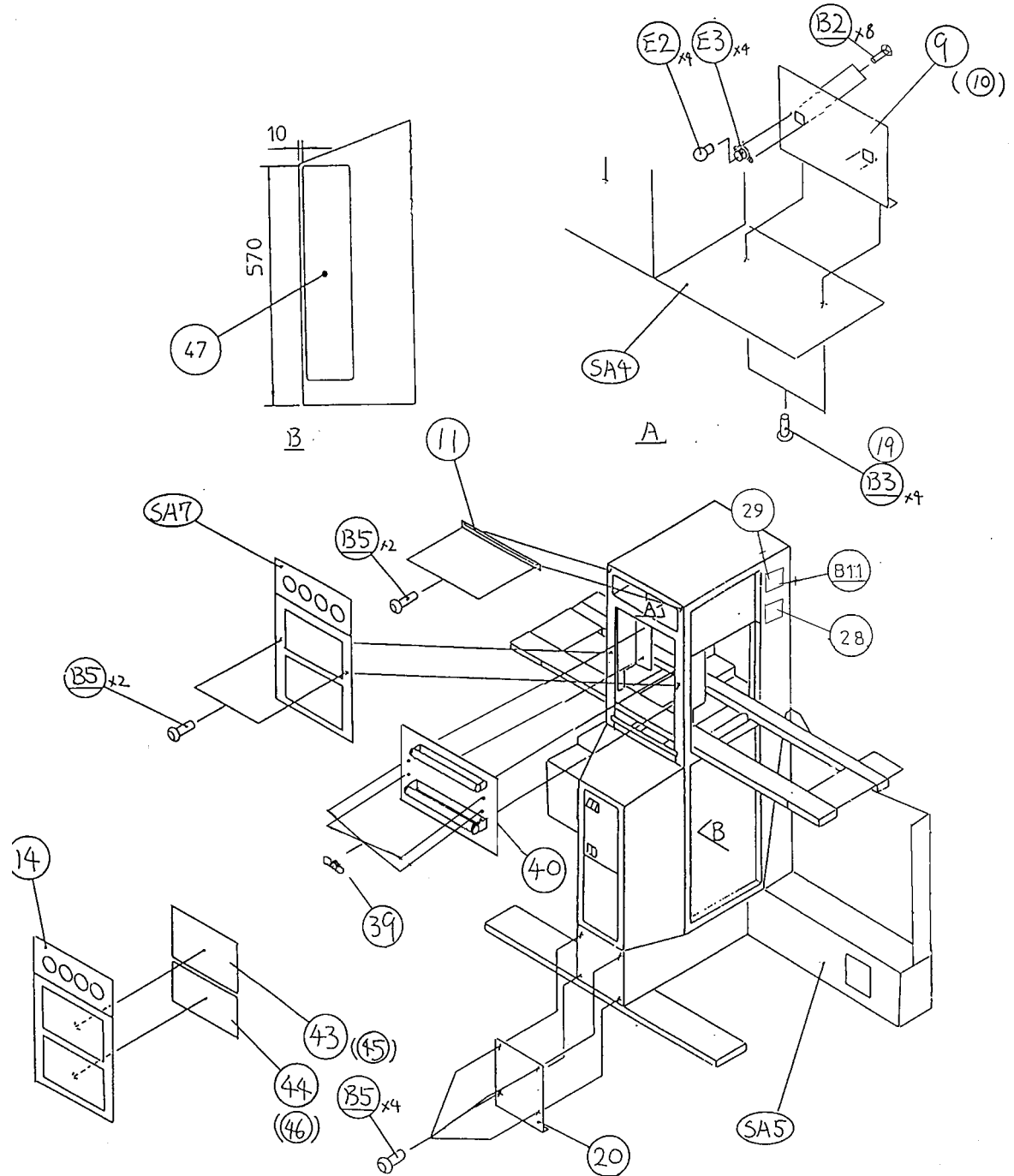

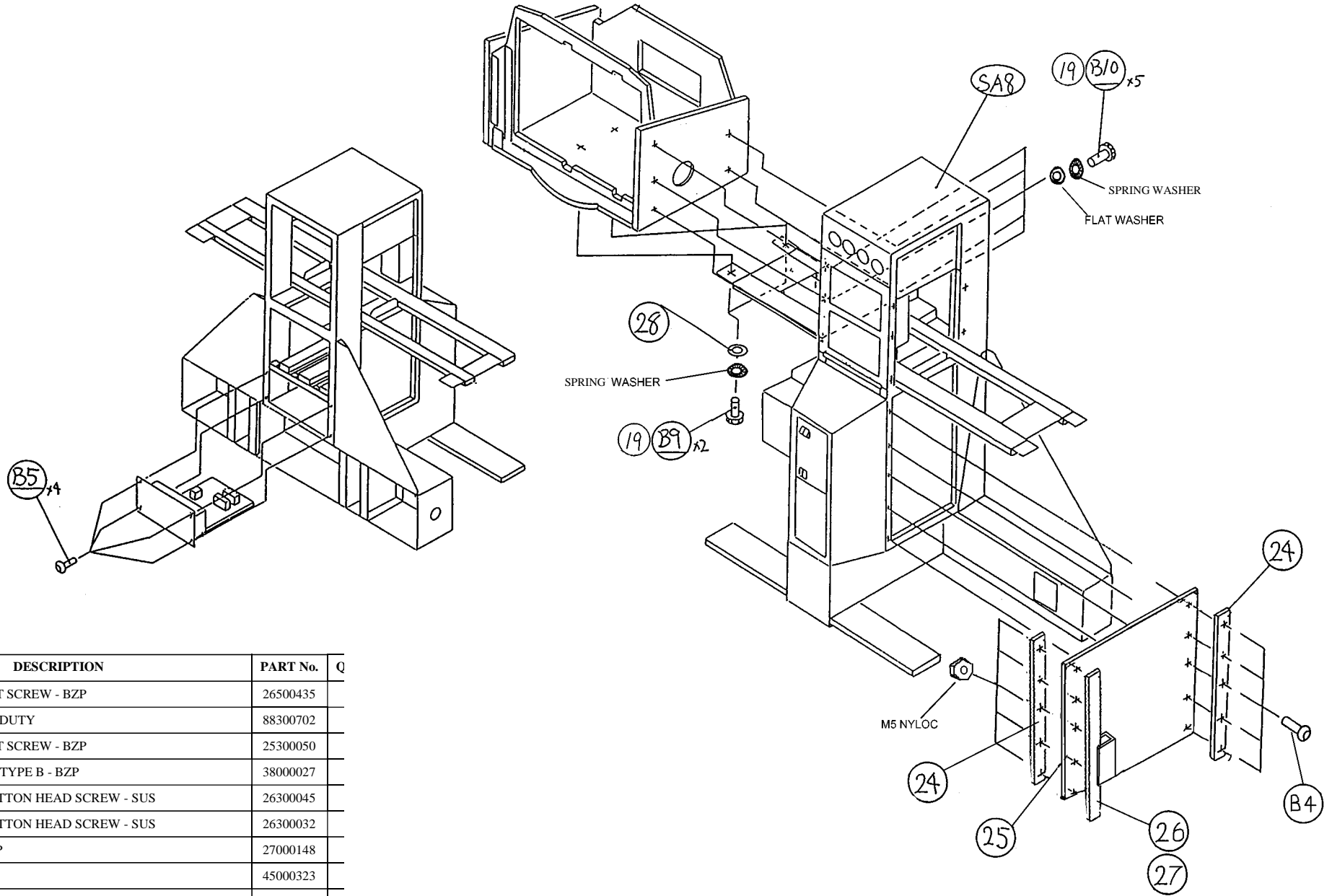

ITEM	DESCRIPTION	PART No.	Q
B10	M8x45 HEX HEAD SET SCREW - BZP	26500435	
	M8 FLAT WASHER H/DUTY	88300702	
B9	M8x25 HEX HEAD SET SCREW - BZP	25300050	
	M8 SPRING WASHER TYPE B - BZP	38000027	
B5	M5x12 SECURITY BUTTON HEAD SCREW - SUS	26300045	
B4	M5x16 SECURITY BUTTON HEAD SCREW - SUS	26300032	
	M5 NYLOC NUT - BZP	27000148	
28	WASHER - BZP	45000323	
27	TOWER/BASE SEAT JOINT BRKT - LHS	45000307	
26	TOWER/BASE SEAT JOINT BRKT - RHS	45000308	
25	TOWER/BASE JOINT RUBBER	45000310	
24	TOWER./BASE SEAT JOINT BRACKET PLATE	45000309	

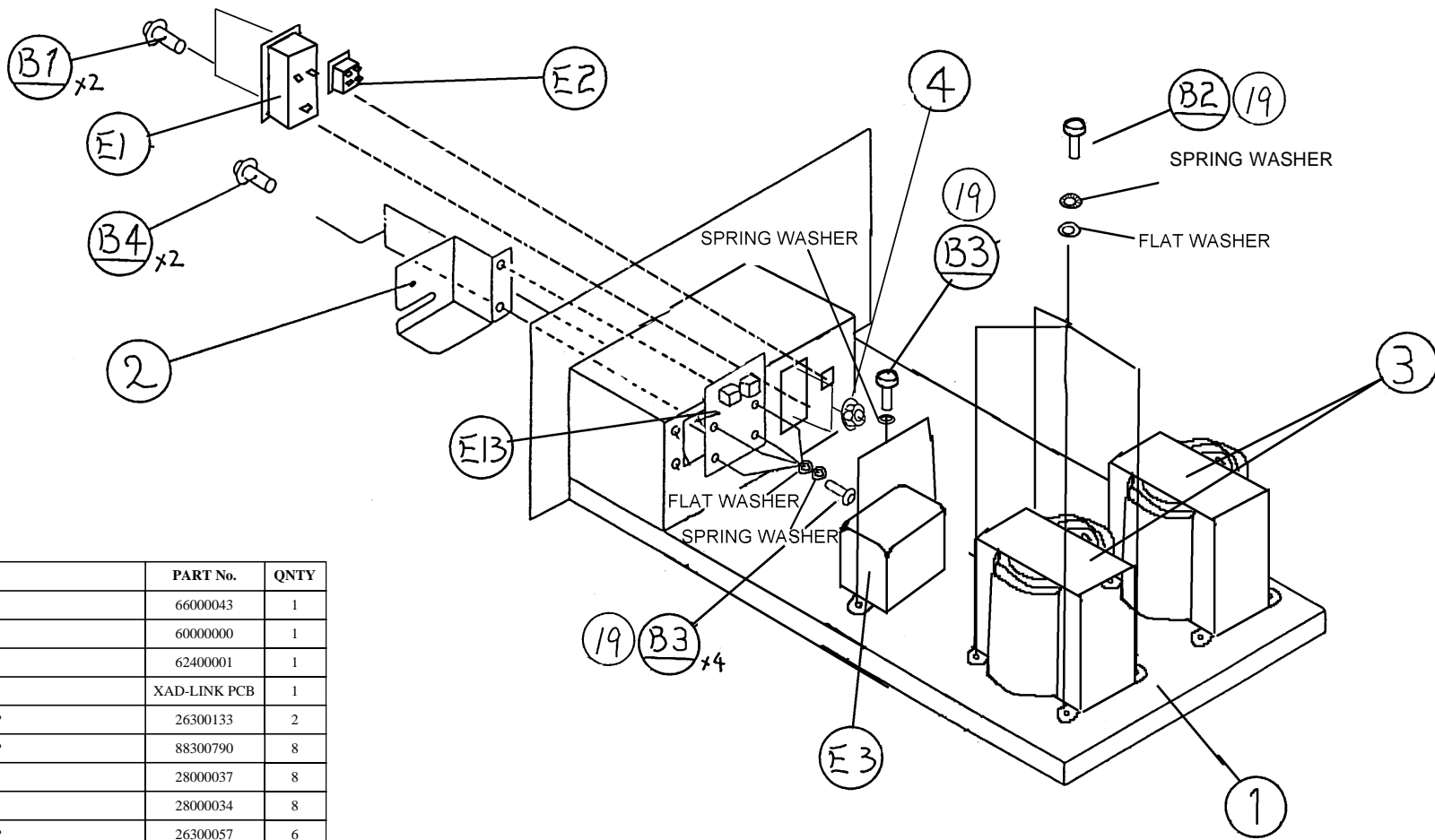

ITEM	DESCRIPTION	PART No.	QNTY
E1	SCHAFFNER IEC MAINS INLET	66000043	1
E2	MAIN S SWITCH - D/POLE	60000000	1
E3	MAIN S FILTER	62400001	1
E13	LINK PCB ASSEMBLY	XAD-LINK PCB	1
B1	M3x12 POZI PAN HEAD SCREW - BZP	26300133	2
B2	M6x16 POZI PAN HEAD SCREW - BZP	88300790	8
	M6 FLAT WASHER H/DUTY - BZP	28000037	8
	M6 SPRING WASHER TYPE B - BZP	28000034	8
B3	M4x12 POZI PAN HEAD SCREW - BZP	26300057	6
	M4 FLAT WASHER H/DUTY - BZP	28000036	4
	M4 SPRING WASHER TYPE B - BZP	28000035	6
B4	M5x12 SECURITY BUTTON HEAD SCREW - SUS	26300045	2
19	LOCTITE 242	95000009	
1	TRANSFORMER TRAY	45000313	1
2	LINK PCB COVER BRKT	45000370	1
3	TRANSFORMER 0-220-240 / 0-100 @ 5A	67700013	2
4	M3 NYLOC NUT	27000026	2
	SCHAFFNER BOOT	66000017	1

ITEM	DESCRIPTION	PART No	QNTY
B1	M4x12 POZI PAN HEAD SCREW - BZP	26300383	2
B2	M4 SPRING WASHER TYPE B - BZP	28000018	2
B3	M4x30 SLOTLESS HEAD SCREW - BZP	26500185	2
B4	M4 WING NUT - BZP	27000129	2
19	LOCTITE 242	95000009	
6	COIN ENTRY BLANKING PLATE	21000055	1
5	"CREDIT AVAILABLE WHEN LIT" BUTTON ASSY	60200215	2
4	PUBLIC INFORMATION DECAL	42000006	1
3	SERVICE BRACKET ASSEMBLY	-----	1
2	DOUBLE FRAME MINI DOOR - CASHFLOW	65500377	1
1	COIN TOWER	45000289	1

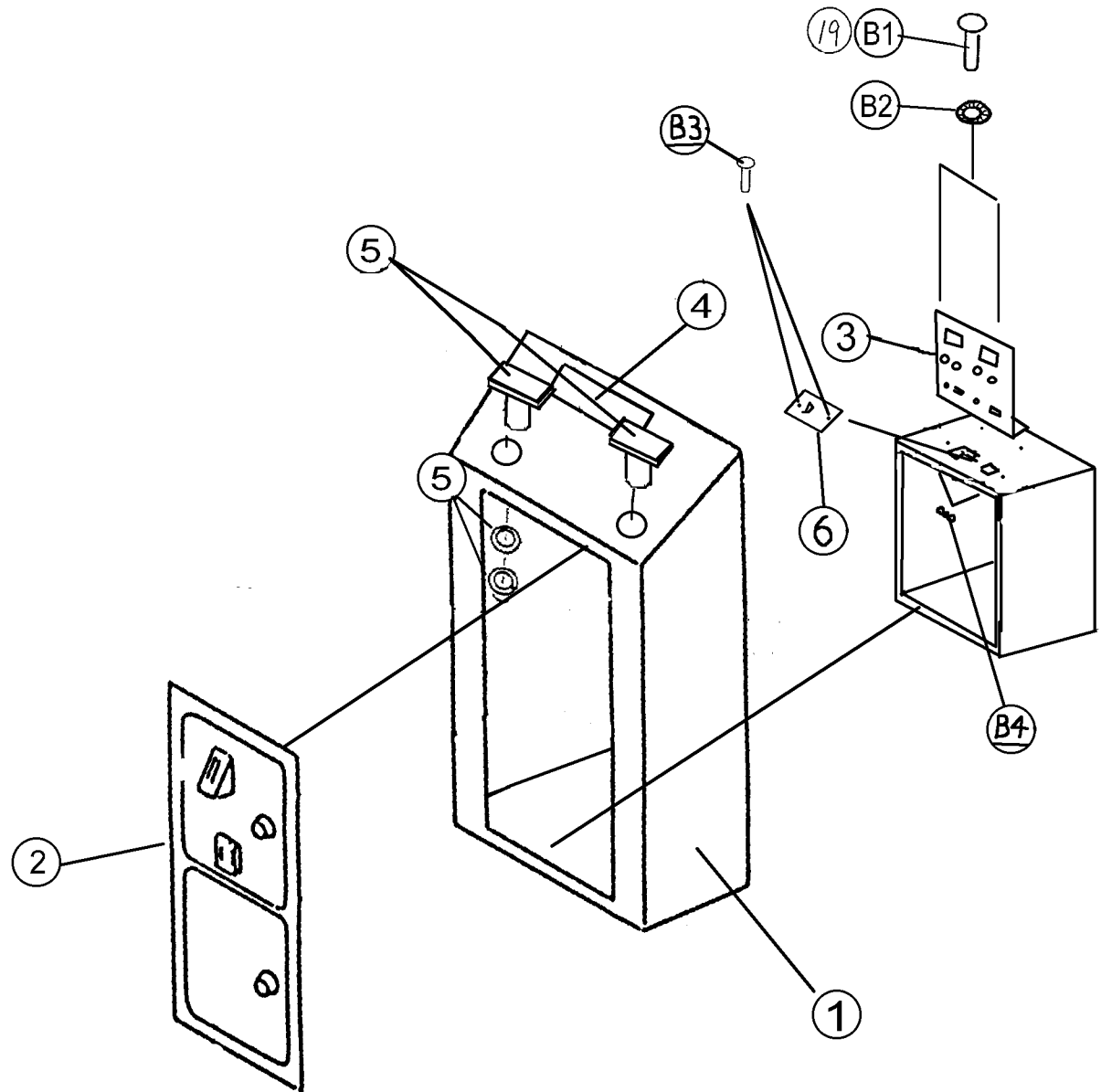

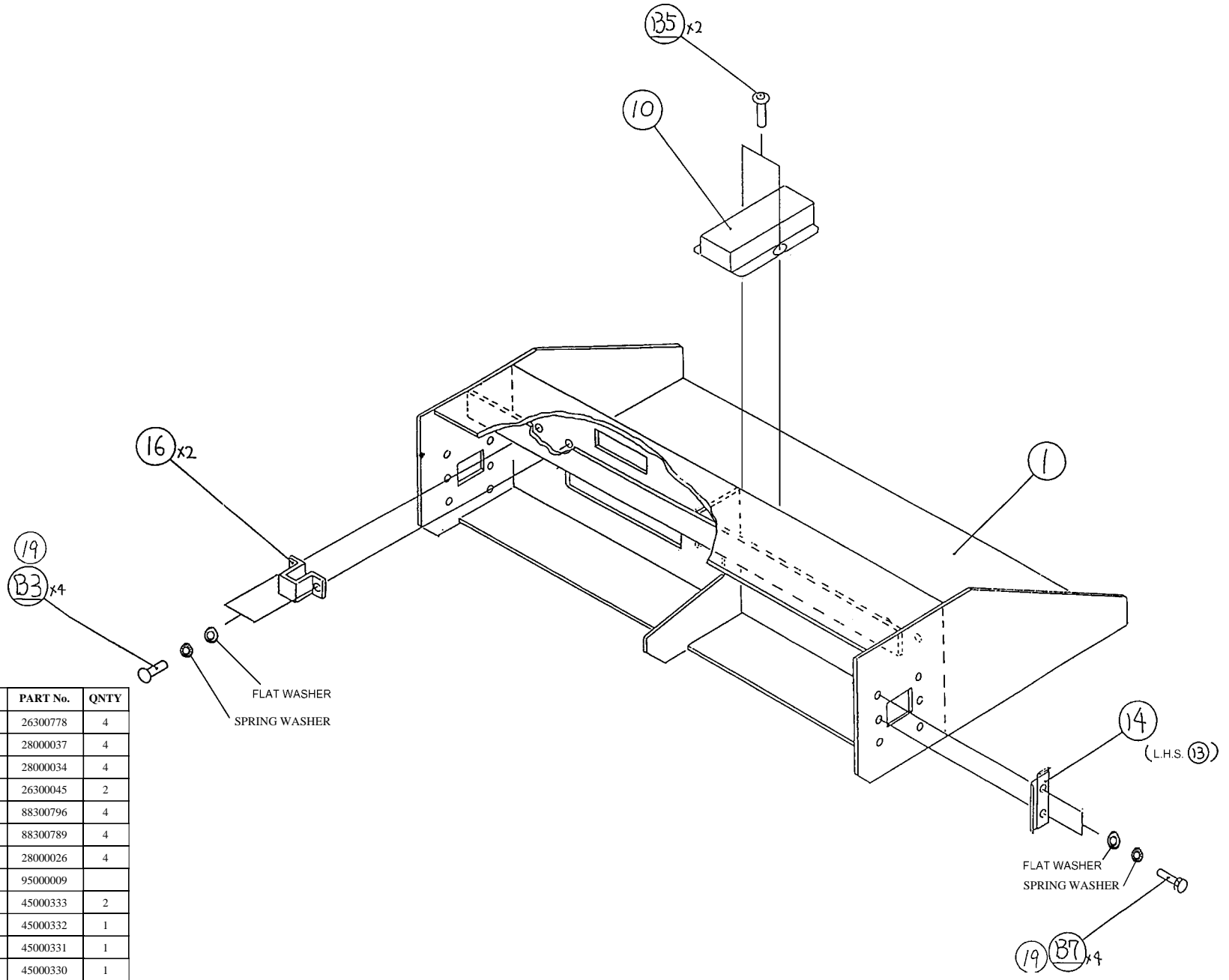

ITEM	DESCRIPTION	PART No.	QNTY
B7	M6x20 HEX HEAD SET SCREW - BZOP	26300778	4
	M6 FLAT WASHER H/DUTY - BZP	28000037	4
	M6 SPRING WASHER TYPE B - BZP	28000034	4
B5	M5x12 SECURITY BUTTON HEAD SCREW - SUS	26300045	2
B3	M5x20 HEX HEAD SET SCREW - BZP	88300796	4
	M5 FLAT WASHER H/DUTY - BZP	88300789	4
	M5 SPRING WASHER TYPE B - BZP	28000026	4
19	LOCTITE 242	95000009	
16	FLOURESCENT TUBE ASSY MNTG BRKT	45000333	2
14	POSITION BOX MOUNTING BRKT - RHS	45000332	1
13	POSITION BOX MOUNTING BRKT - LHS	45000331	1
10	TOP EXTERNAL CABLE COVER BRKT	45000330	1
1	MAIN HEADER WOODEN BOX	37100039	1

ITEM	DESCRIPTION	PART No.	QNTY
E5	4ft FLUORESCENT TUBE ASSY	6400045	1
E2	MES LAMP HOLDER	64800003	6
E1	240v 25w SES SILVERED LAMP	64000083	6
B4	M5x20 HEX HEAD SET SCREW - BZP	88300796	4
B3	M5x16 HEX HEAD SET SCREW - BZP	26500431	2
	M5 FLAT WASHER H/DUTY - BZP	88300789	6
	M5 SPRING WASHER TYPE B - BZP	28000026	6
B1	No.4 x 1/2" PZ PAN HEAD SCREW - BZP	26100070	12
19	LOCTITE 242	95000009	
9	LEADER LAMP MOUNTING BRACKET	45000329	2

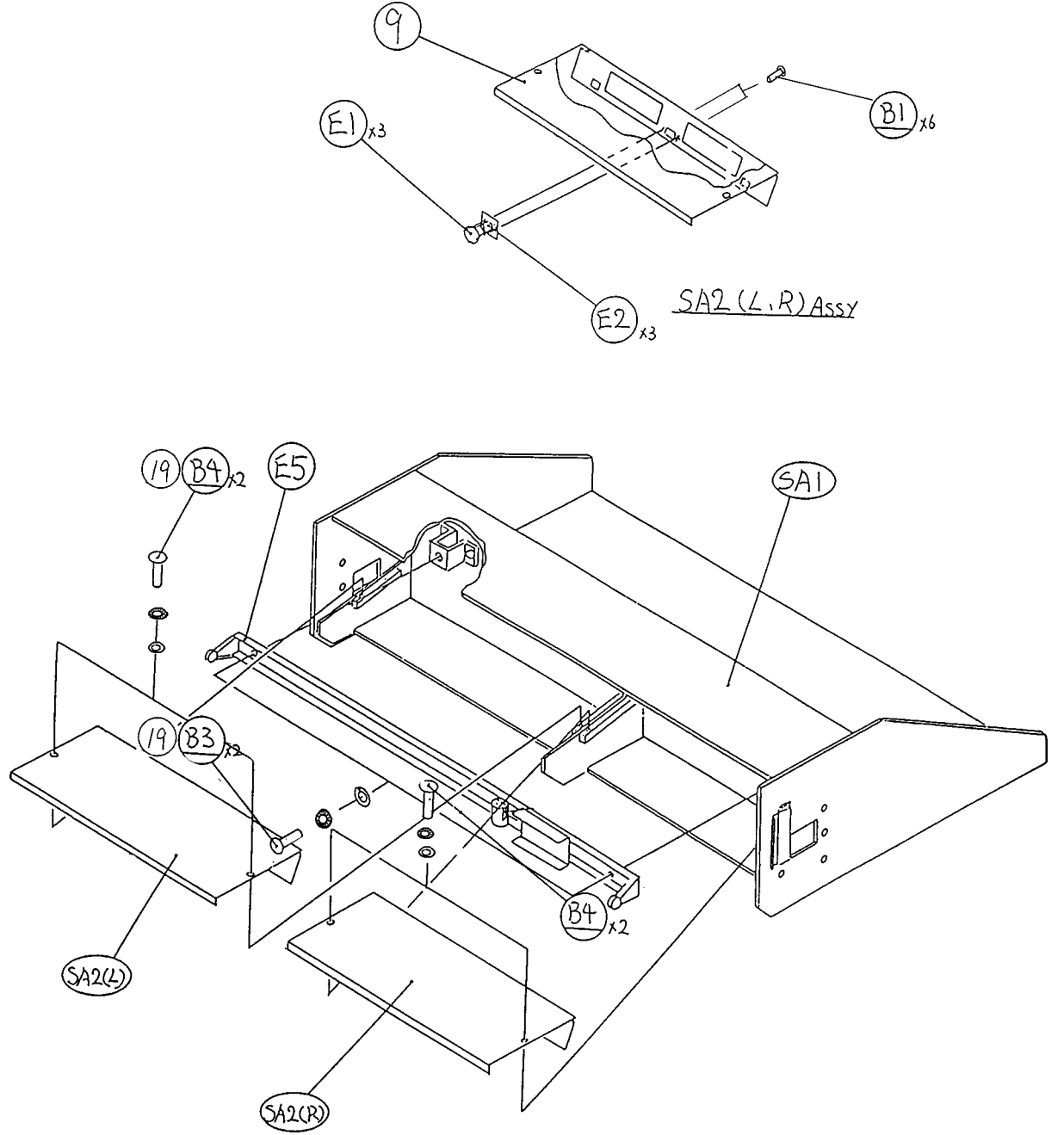

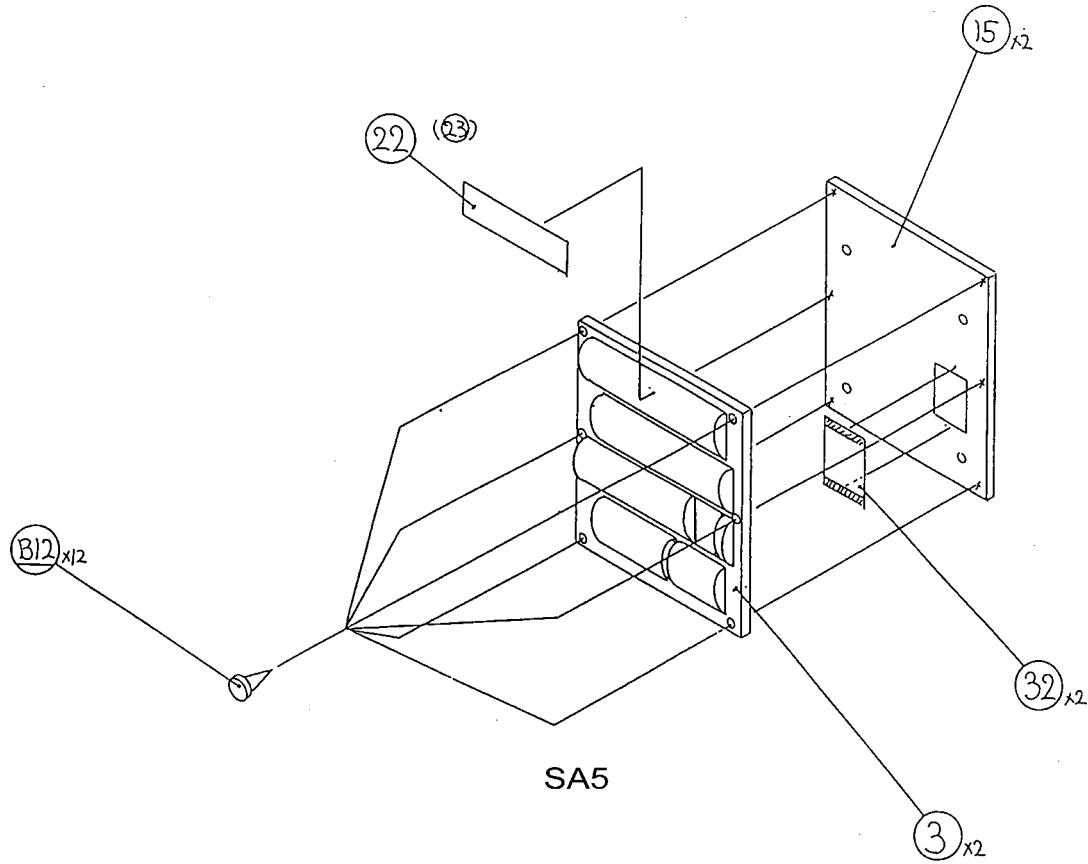

SA5

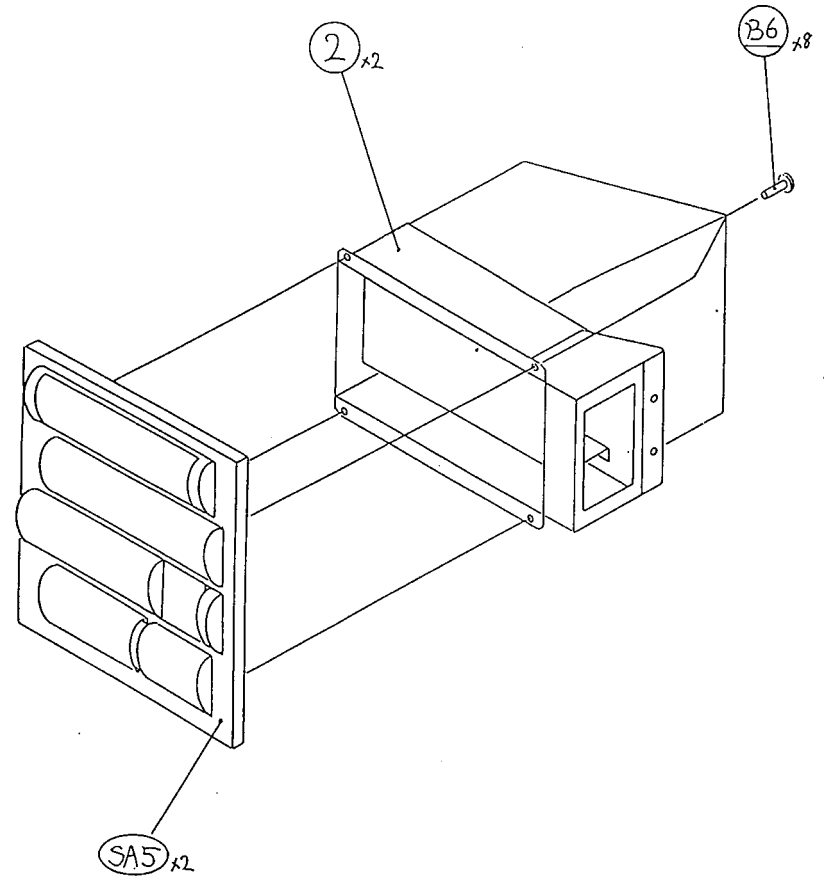

ITEM	DESCRIPTION	PART No.
B12	M5x10 SECURITY BUTTON HEAD SCREW - SUS	26300043
B6	M6x16 SECURITY BUTTON HEAD SCREW - SUS	26300044
32	SEVEN SEGMENT DISPLY FILTER	39000048
23	POSITION VAC-FORM CAR STICKER - GREEN	A 40000210
22	POSITION VAC-FORM CAR STICKER - YELLOW	
23	POSITION VAC-FORM CAR STICKER - BLUE	B 40000212
22	POSITION VAC-FORM CAR STICKER - RED	
19	LOCTITE 242	95000009
15	POSITION VAC-FORM MOUNTING WOOD	37100040
3	POSITION VAC-FORM	45000325
2	POSITION BOARD MOUNTING BOX	45000324

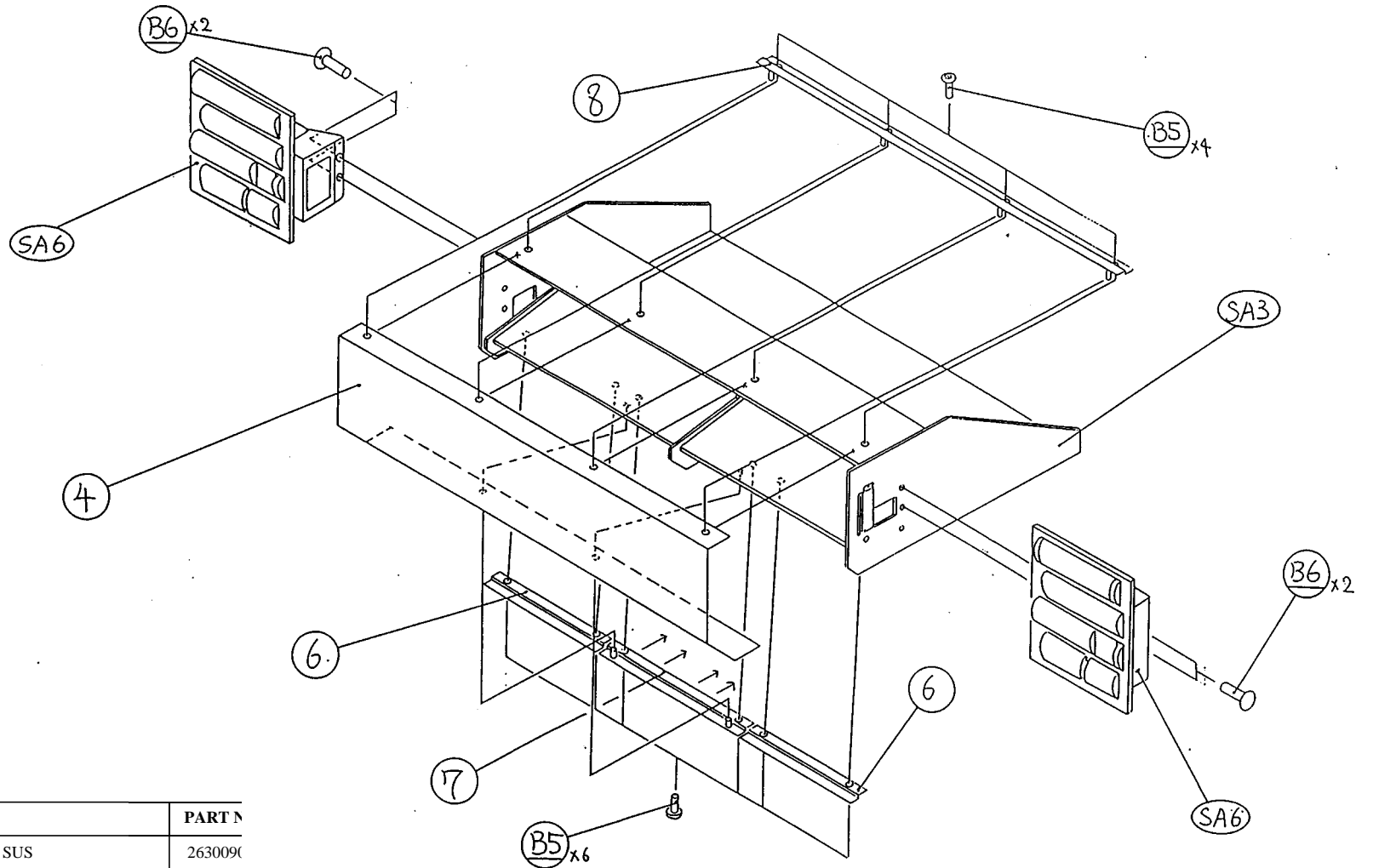

ITEM	DESCRIPTION	PART N
B6	M6x20 SECURITY BUTTON HEAD SCREW - SUS	2630090
B5	M5x12 SECURITY BUTTON HEAD SCREW - SUS	2630002
19	LOCTITE 242	9500000
8	TOP FLASH ACRYLIC RETAINING BRKT - TOP	4500032
7	TOP FLASH ACRYLIC RETAINING BRKT - BOTTOM	4500032
6	TOP FLASH ACRYLIC RETAINING BRKT - BOTTOM	4500032
4	TOP FLASH ACRYLIC - GREEN/YELLOW	A 3000002
4	TOP FLASH ACRYLIC - RED/BLUE	B 3000002

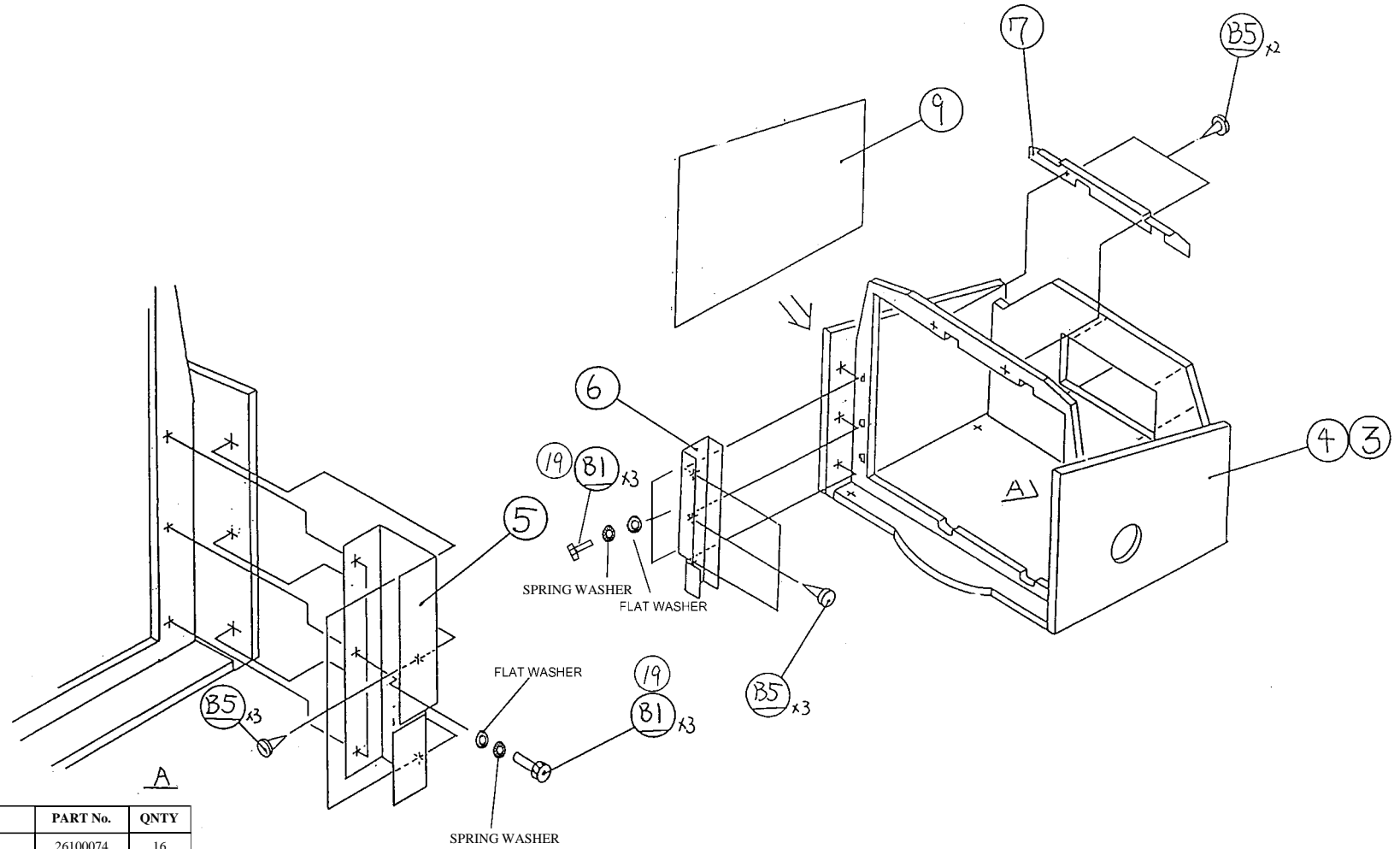

ITEM	DESCRIPTION	PART No.	QNTY
B5	No.6 x 1/2" PZ FLANGE SCREW	26100074	16
B1	M8x40 HEX HEAD SET SCREW - BZP	26500433	12
	M8 FLAT WASHER H/DUTY - BZP	88300702	12
	M8 SPRING WASHER TYPE B - BZP	28000027	12
19	LOCTITE 242	95000009	
9	MONITOR CABINET SIDE DECAL - LHS	40000207	1
	MONITOR CABINET SIDE DECAL - RHS	40000208	1
7	MONITOR TOP SUPPORT BRACKET	45000322	2
6	TUBE MOUNTING WOOD SIDE SUPPORT - LHS	45000320	2
5	TUBE MOUNTING WOOD SIDE SUPPORT - RHS	45000321	2
4	MONITOR WOODEN CABINET-LHS	37100042	1
3	MONITOR WOODEN CABINET-RHS	37100043	1

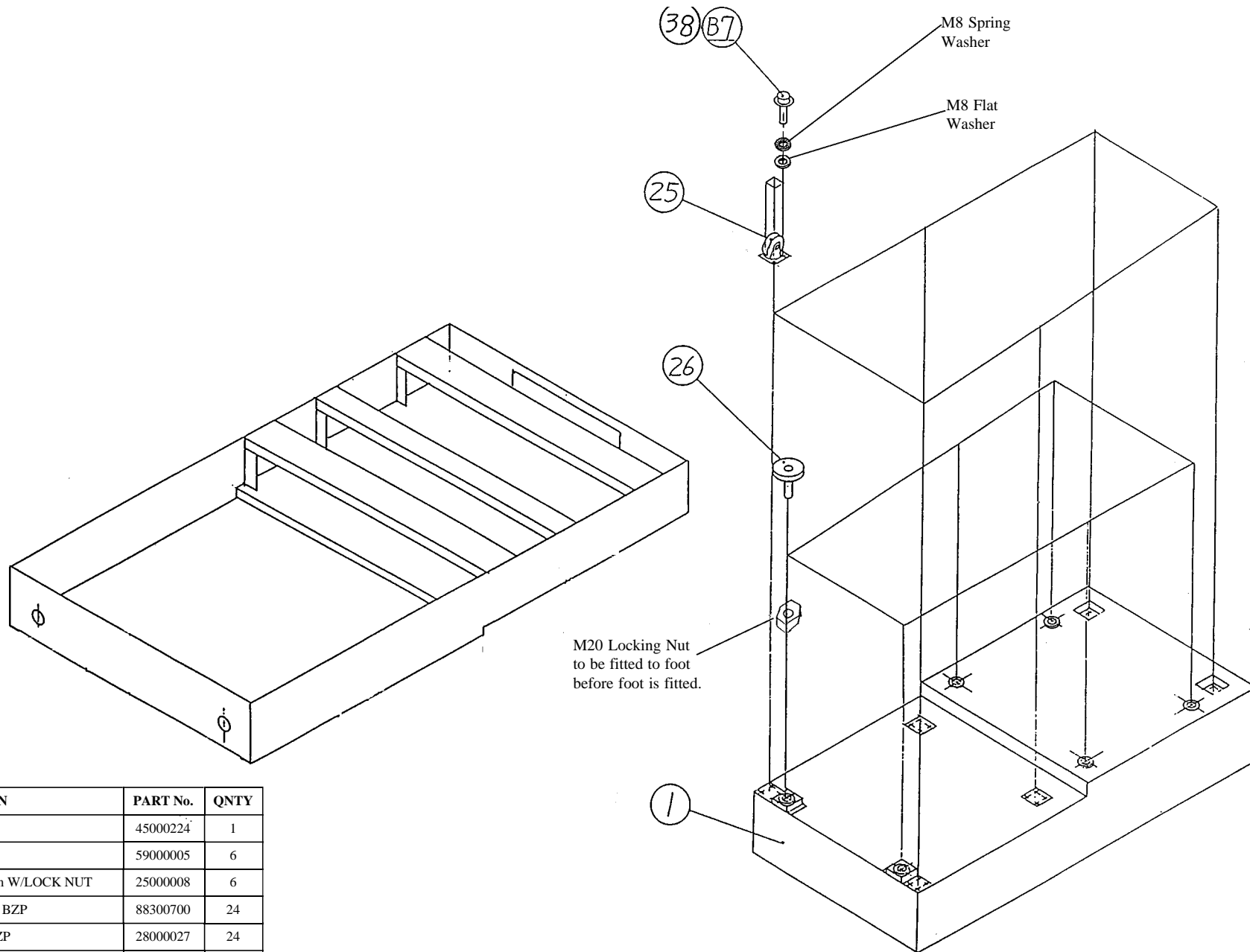

ITEM	DESCRIPTION	PART No.	QNTY
1	MAIN BASE METALWORK	45000224	1
25	SWIVEL CASTOR 75mm	59000005	6
26	ADJUSTABLE FOOT M20x100mm W/LOCK NUT	25000008	6
B7	M8x20 HEX HEAD SET SCREW - BZP	88300700	24
	M8 FLAT WASHER H/DUTY - BZP	28000027	24
	M8 SPRING WASHER TYPE B - BZP	88300702	24
38	LOCTITE 262	95000003	-

ITEM	DESCRIPTION	PART No.	QNT
E3	DRIVE MOTOR & GEARBOX	45000241	1
B6	M8x16 HEX HEAD SET SCREW - BZP	88300795	3
B12	M8 SPRING WASHER TYPE B - BZP	28000027	7
B13	M8x20 HEX HEAD SET SCREW - BZP	88300700	4
B14	M10 FULL NUT 1.25 PITCH - BZP	27000197	1
B17	M10 FLAT WASHER H/DUTY - BZP	88300794	2
B19	M10 SPRING WASHER TYPE B - BZP	28000023	1
6	MOTOR DRIVE DRUM	45000235	1
8	DRIVE SHAFT	45000230	1
9	DRIVE MOTOR MOUNTING BRACKET	45000244	1
11	FRONT CONTROL ARM	45000231	1
12	REAR CONTROL ARM	45000232	1
13	TAPER LOCK BUSHING - 25mm	45000456	1
14	WASHER 40x8.5x3.2 - BZP	45000233	3
15	DUAL V BELT PULLEY BLOCK	45000237	1
16	TAPER LOCK BUSHING - 5/8"	45000457	1
22	WOODRUFF KEY 8x7x40	45000234	2
23	WOODRUFF KEY 8x7x25	45000238	2
28	RIGHT ANGLE DUAL BALL JOINT ASSY	45000276	2
	M10x48 THREADED STUD - BZP	26500427	1
	M10 THIN FULL NUT - BZP	27000024	2
29	PILLOW BEARING - FYH UCP X07	45000236	2
30	PILLOW BEARING - FYH BLP 205	45000229	2
44	WASHER	45000239	1
45	WASHER	45000240	1
38	LOCTITE 242	95000009	

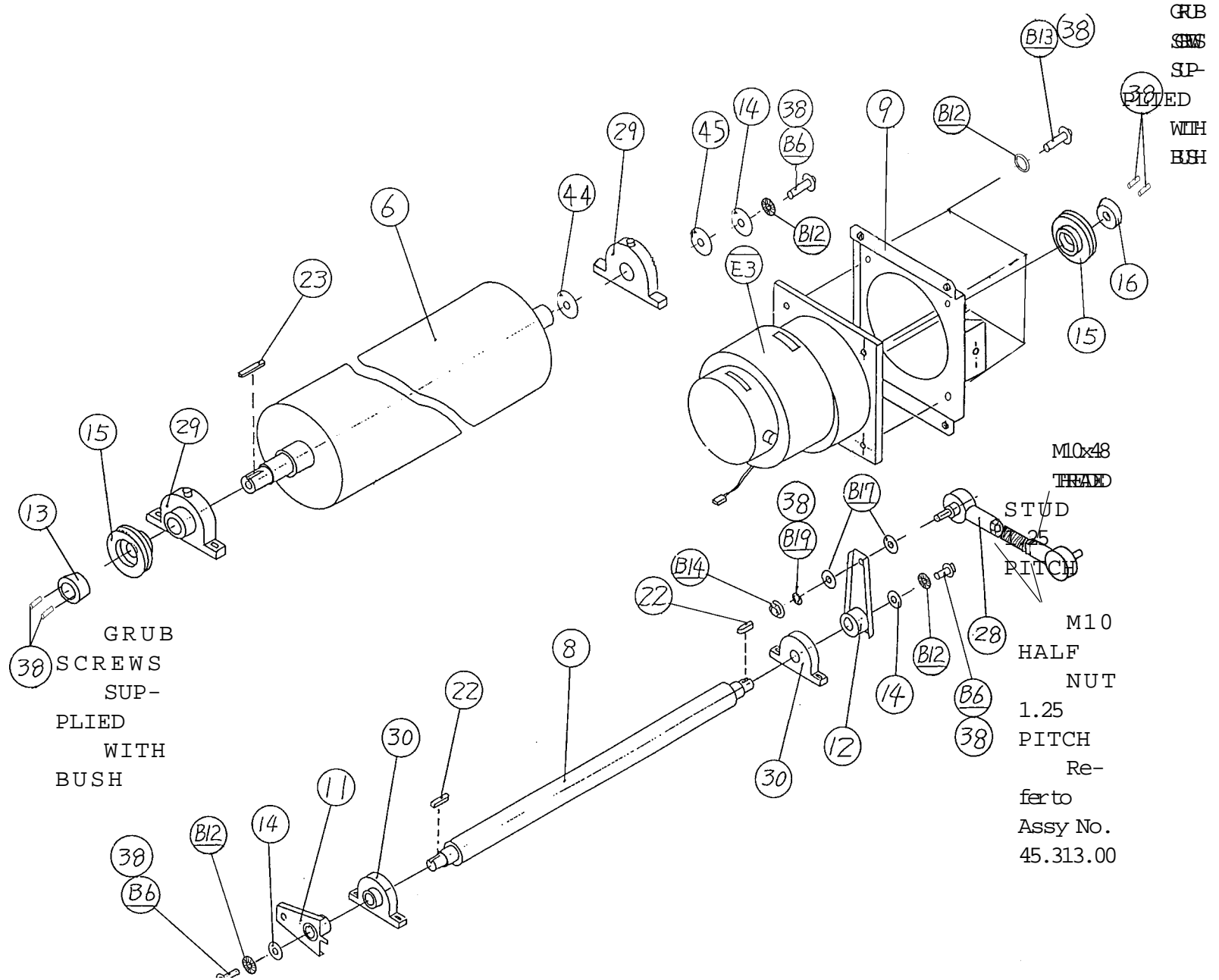

GRUB
SCREWS
SUP-
PLIED
WITH
BUSH

ITEM	DESCRIPTION	PART No.	QNTY
B7	M8x20 HEX HEAD SET SCREW - BZP	88300700	4
	M8 FLAT WASHER H/DUTY - BZP	88300702	4
	M8 SPRING WASHER TYPE B - BZP	88300027	4
B10	M10x80 HEX HEAD SET SCREW - BZP	26500439	1
B11	M12x50 HEX HEAD SET SCREW - BZP	26500438	4
	M12 FLAT WASHER H/DUTY - BZP	28000020	4
	M12 SPRING WASHER TYPE B - BZP	28000019	4
B15	M10 FULL NUT - BZP	27000023	1
B17	M10 FLAT WASHER H/DUTY - BZP	88300794	5
B18	M14 FLAT WASHER H/DUTY - BZP	28000021	5
24	V DRIVE BELT 3V-355	45000243	2
38	LOCTITE 242	95000009	

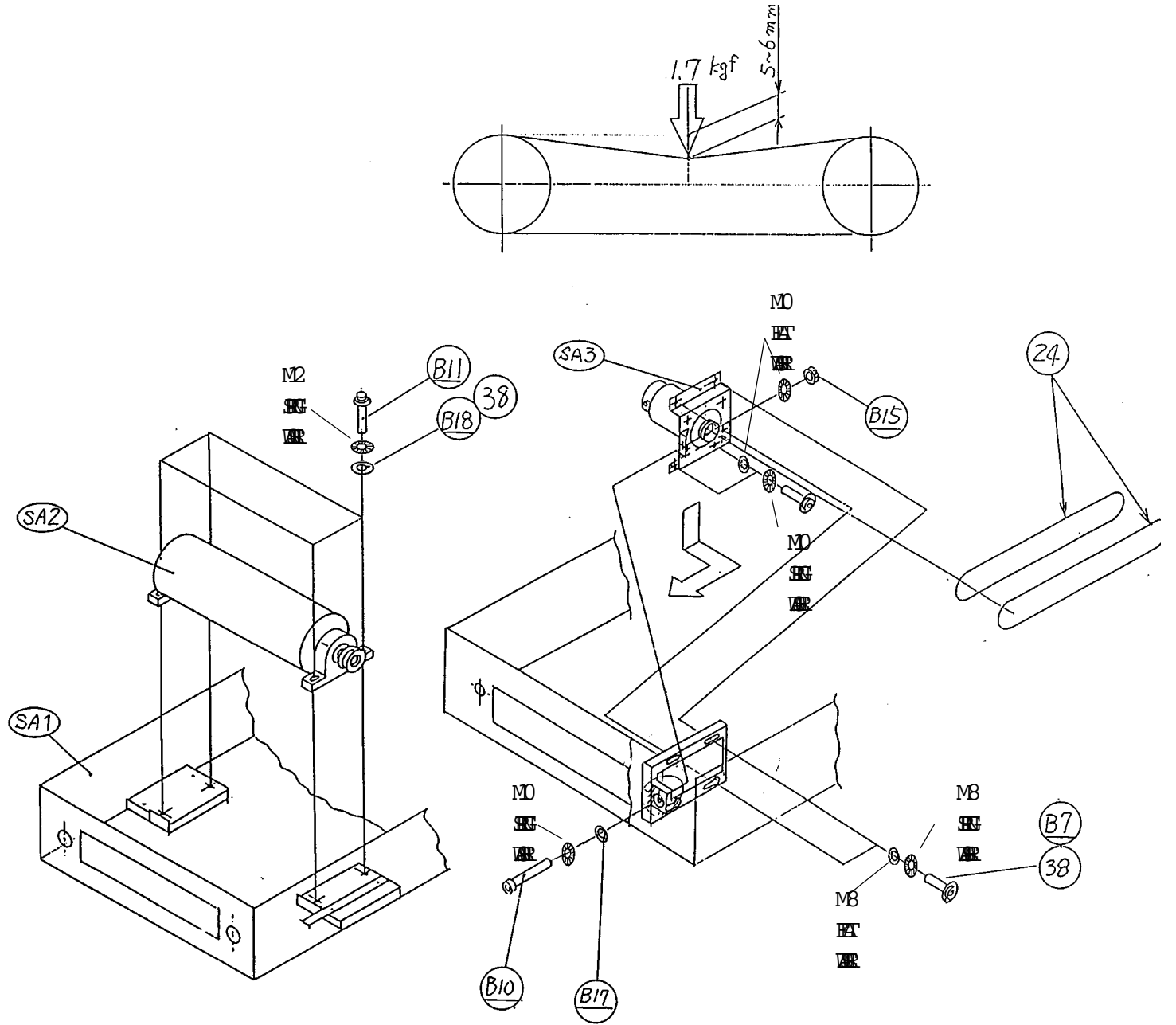

ITEM	DESCRIPTION	PART No.	QNTY
E11	DPCO TOGGLE SWITCH	T.B.A.	1
E6	20mm FUSE HOLDER - PANEL MOUNT	T.B.A	1
E5	20mm FUSE 5A SLO-BLO	63500600	1
E2	MOTION STOP PCB	45000442	1
E1	DRIVE MOTOR PCB		1
B22	M18 FLAT WASHER H/DUTY - BZP	28000025	2
B20	M18 SPRING WASHER TYPE B - BZP	28000024	2
B16	M18 FULL NUT 1.25 PITCH - BZP	27000208	1
B12	M18x50 HEX HEAD SET SCREW 1.25 PITCH- BZP	26500414	1
B9	M10x40 HEX HEAD SET SCREW	26500437	4
	M10 FLAT WASHER - BZP	88300794	4
	M10 SPRING WASHER TYPE B - BZP	28000023	4
B3	M5x12 PZ PAN HEAD SCREW - BZP	26300575	16
	M5 FLAT WASHER H/DUTY - BZP	28000032	16
	M5 SPRING WASHER TYPE B - BZP	28000026	16
B2	M4x12 POZI PAN HEAD SCREW - BZP	26300057	8
	M4 FLAT WASHER - BZP	28000036	8
	M4 SPRING WASHER TYPE B - BZP	28000035	8
B1	M10x40 HEX HEAD SET SCREW - BZP	26500437	2
	M10 FLAT WASHER H/DUTY - BZP	88300794	2
	M10 SPRING WASHER TYPE B - BZP	28000023	2
42	FUSE LABEL 5A		1
41	DRIVE MOTOR PCB MOUNTING BRACKET	45000242	1
38	LOCTITE 242	95000009	
31	BLIND HOLE GROMMET	45000246	2
27	MOUNTING PIVOT - THK RBI 18D	45000227	1
16	BALL JOINT/SEAT BED LOCATING BRKT	45000228	1
13	SUS 304 ROLLER BRACKET	45000226	3

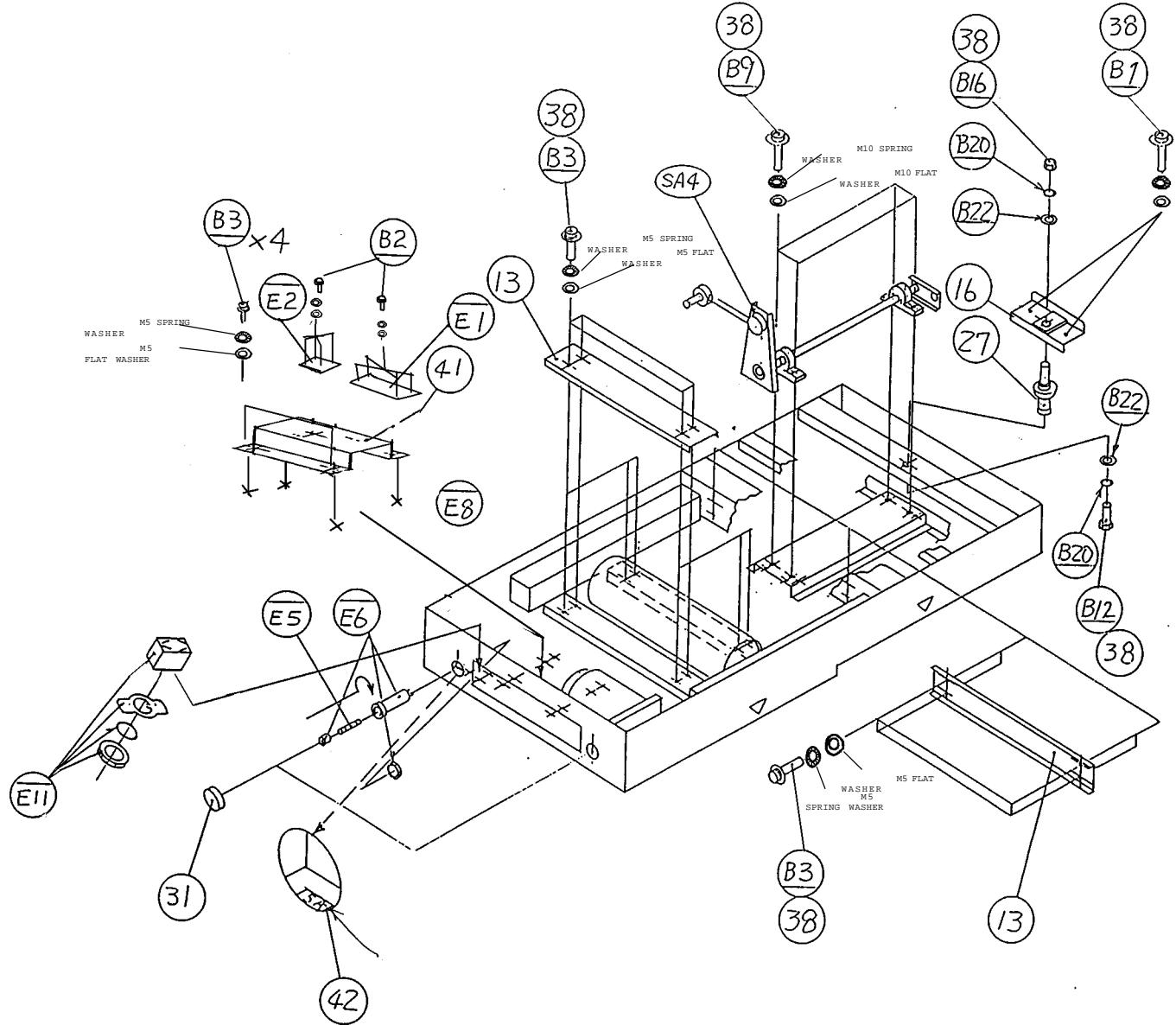

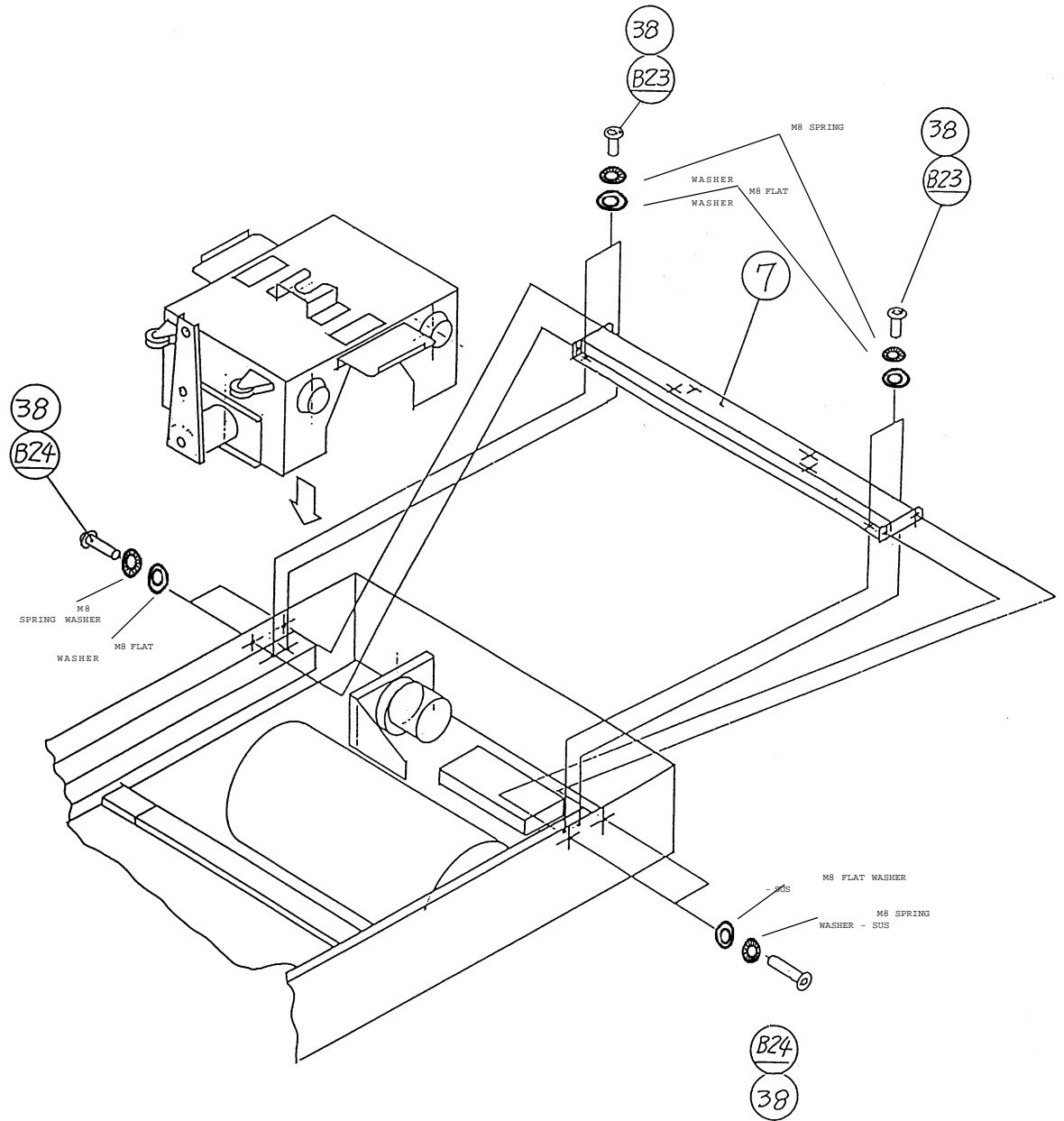
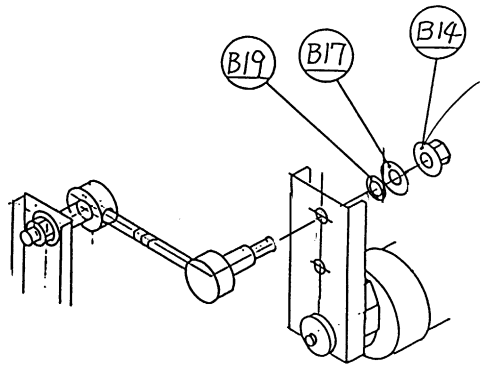

ITEM	DESCRIPTION	PART No.	QNTY
B24	M8x40 SECURITY BUTTON HEAD SCREW - SUS	26300047	4
B23	M8x20 HEX HEAD SET SCREW - BZP	88300700	4
	M8 FLAT WASHER H/DUTY - BZP	28000027	4
	M8 SPRING WASHER TYPE B - BZP	88300702	4
B19	M10 FLAT WASHER H/DUTY - BZP	88300794	1
B17	M10 SPRING WASHER TYPE B - BZP	28000023	1
B14	M10 FULL NUT 1.25 PITCH - BZP	27000197	1
38	LOCTITE 242	95000009	
7	MAIN BASE CROSS MEMBER	45000263	1

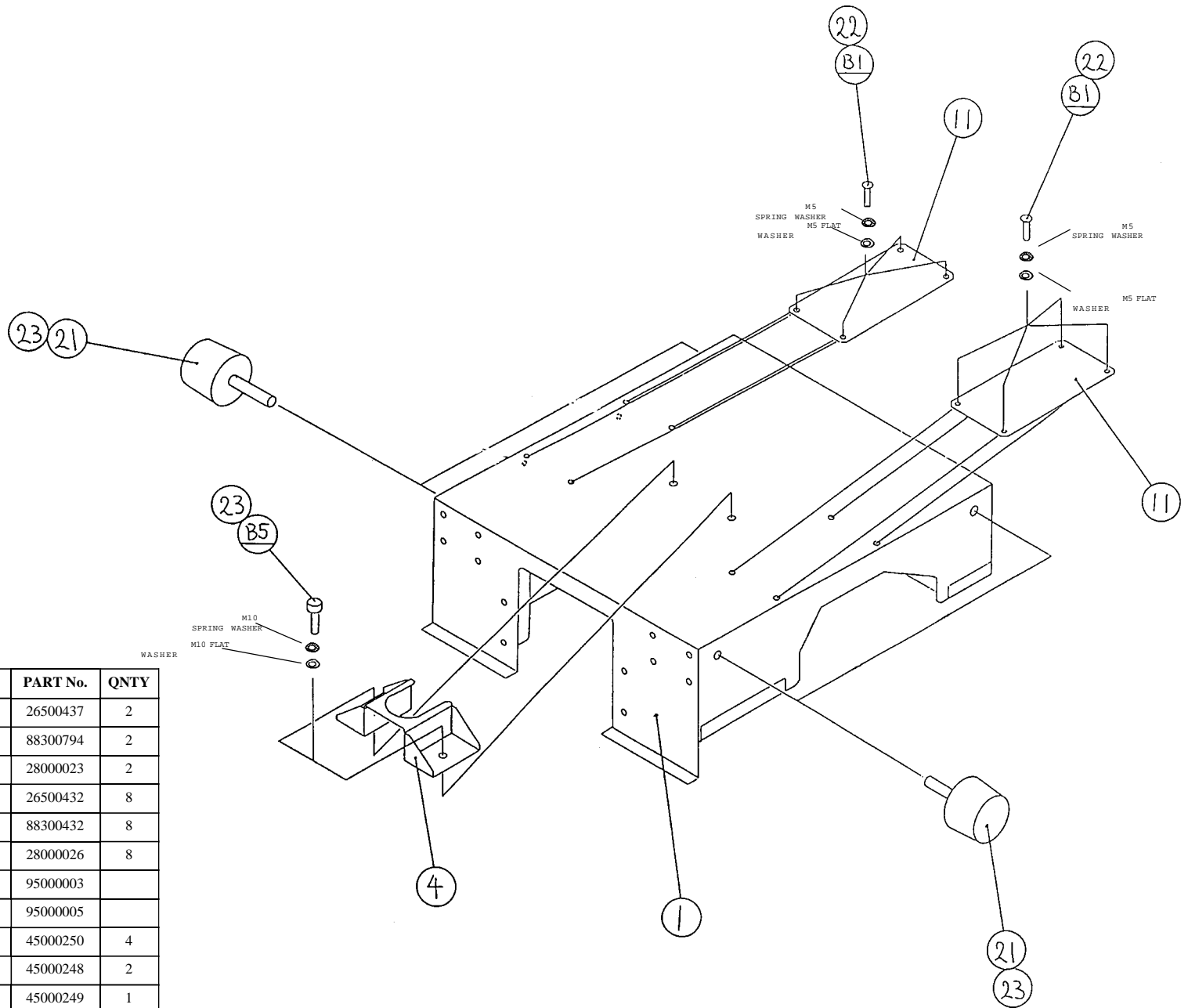

ITEM	DESCRIPTION	PART No.	QNTY
B5	M10x40 HEX HEAD SET SCREW - BZP	26500437	2
	M10 FLAT WASHER H/DUTY - BZP	88300794	2
	M10 SPRING WASHER TYPE B - BZP	28000023	2
B1	M5x12 HEX HEAD SET SCREW - BZP	26500432	8
	M5 FLAT WASHER H/DUTY - BZP	88300432	8
	M5 SPRING WASHER TYPE B - BZP	28000026	8
23	LOCTITE 262	95000003	
22	LOCTITE 242	95000005	
21	SIDE IMPACT BUMPER	45000250	4
11	SUS 304 CASTOR ROLLER PLATE	45000248	2
4	SEAT MOUNTING BRACKET	45000249	1
1	MAIN HOUSING	45000247	1

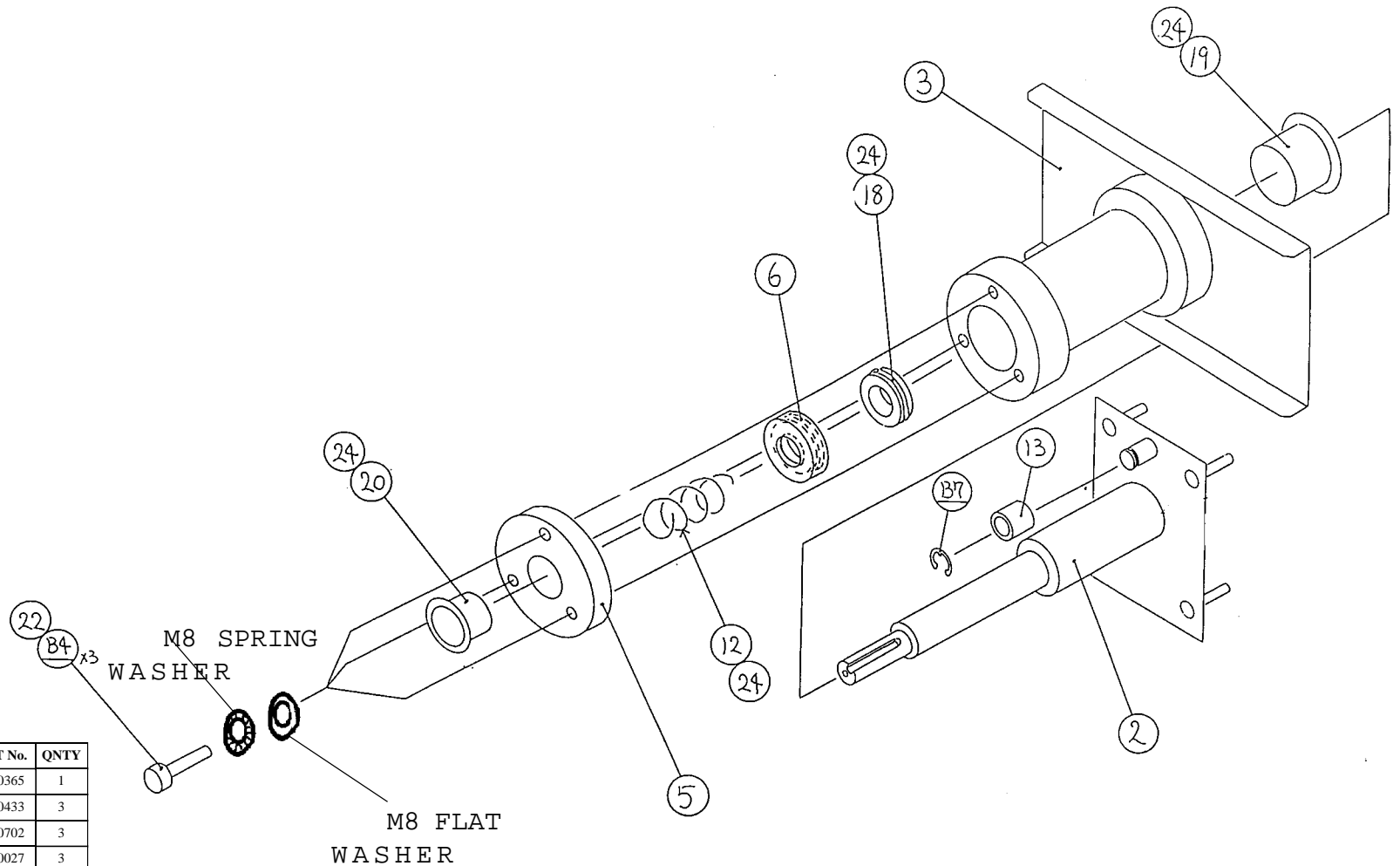

ITEM	DESCRIPTION	PART No.	QNTY
B7	10mm 'E' CLIP	45000365	1
B4	M8x40 HEX HEAD SET SCREW - BZP	26500433	3
	M8 FLAT WASHER H/DUTY - BZP	88300702	3
	M8 SPRING WASHER TYPE B - BZP	28000027	3
24	GREASE LIGHT	95000019	
22	LOCTITE 242	95000005	
20	DELIN BUSH - SMALL	45000262	1
19	DELIN BUSH - LARGE	45000261	1
18	BEARING - NTN 51106	45000260	1
13	NEOPRENE BUMPER	45000259	1
12	TENSION SPRING	45000258	1
6	TENSION SPRING INSERT CAP	45000254	1
5	TENSION SPRING END CAP	45000253	1
3	CASTOR MOUNTING BRACKET ASSEMBLY	45000252	1
2	CASTOR SHAFT	45000251	1

ITEM	DESCRIPTION	PART No.	QNTY
B8	M8x20 HEX HEAD SET SCREW - BZP	88300700	1
	M8 FLAT WASHER H/DUTY - BZP	88300702	1
	M8 SPRING WASHER TYPE B - BZP	28000027	1
B6	M10 FULL NUT - BZP	27000023	4
	M10 FLAT WASHER H/DUTY - BZP	88300794	4
	M10 SPRING WASHER TYPE B - BZP	28000023	4
B2	M8x16 HEX HEAD SET SCREW - BZP	88300795	1
	M8 SPRING WASHER TYPE B - BZP	28000027	1
22	LOCTITE 242	95000009	
17	WOODRUFF KEY 8x7x40	45000234	1
15	DRIVE CASTOR	X102-056	1
14	WASHER 40x8.5x3.2 - BZP	45000233	1
9	ADJUSTING NUT LOCKING BRACKET	45000257	1
8	ADJUSTING NUT M36	45000256	1
7	CONTROL ARM	45000255	1

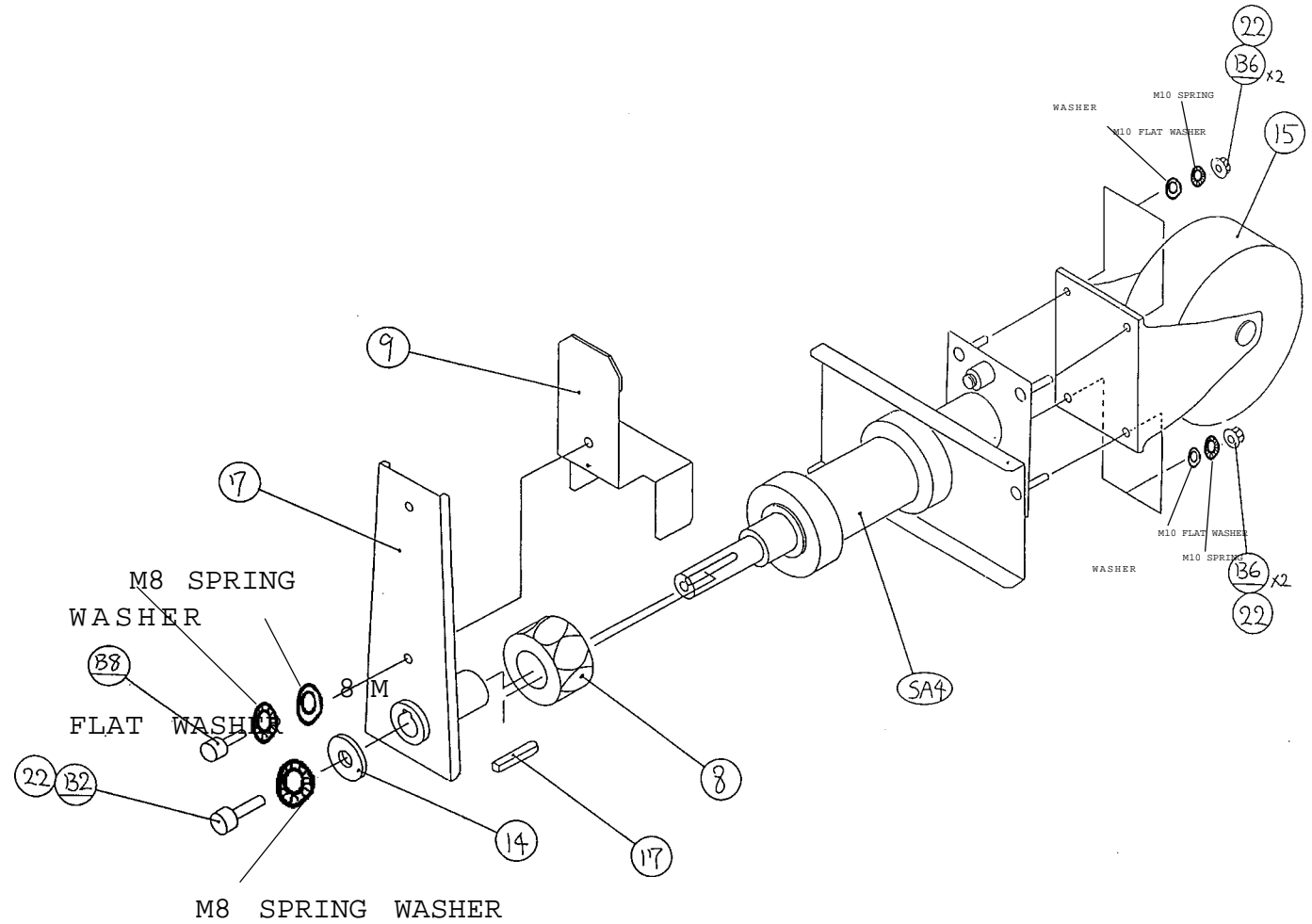

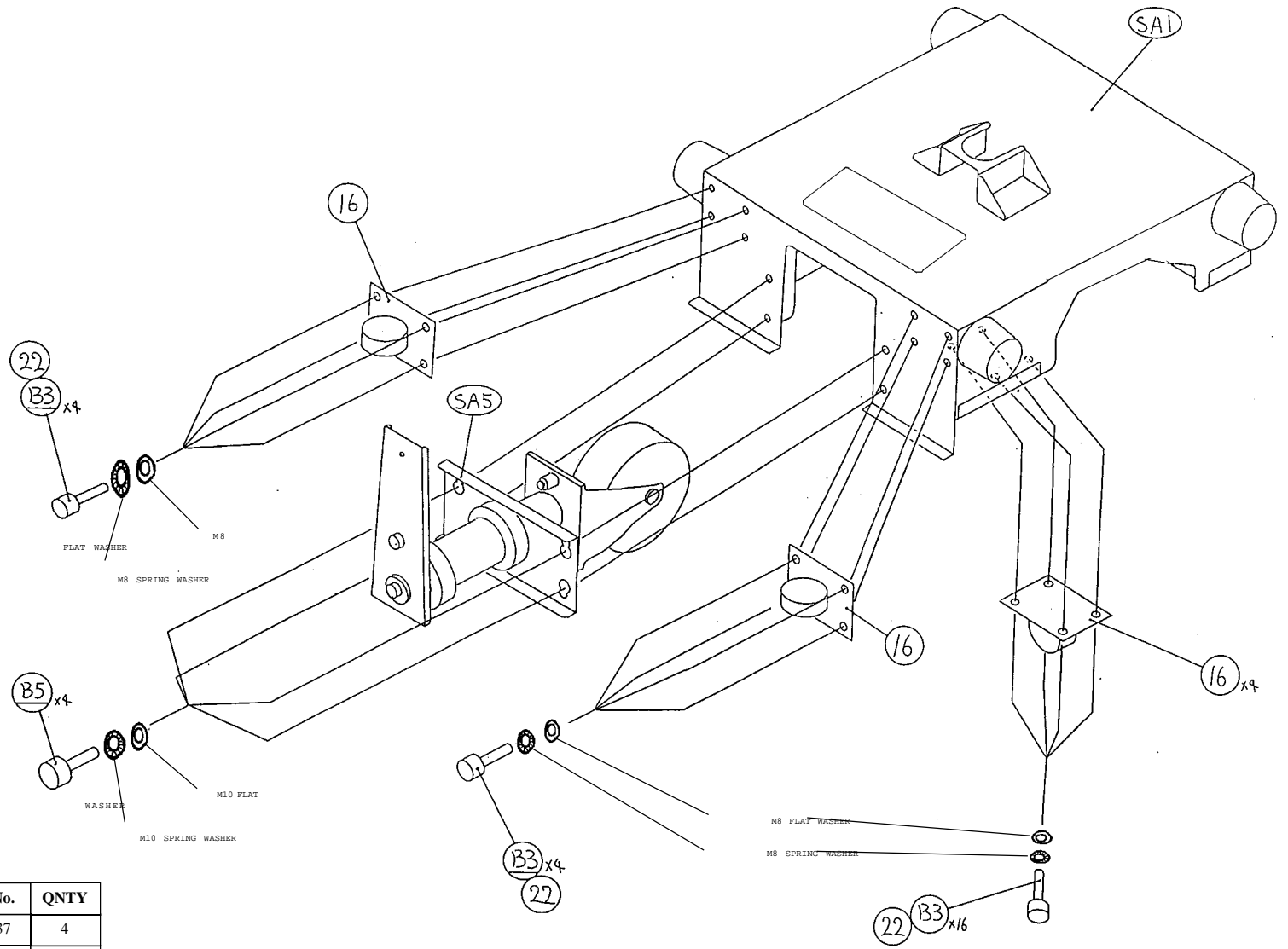

ITEM	DESCRIPTION	PART No.	QNTY
B5	M10x40 HEX HEAD SET SCREW - BZP	26500437	4
	M10 FLAT WASHER H/DUTY - BZP	88300794	4
	M10 SPRING WASHER TYPE B - BZP	28000023	4
B3	M8x20 HEX HEAD SET SCREW - BZP	88300700	24
	M8 FLAT WASHER H/DUTY - BZP	88300702	24
	M8 SPRING WASHER TYPE B - BZP	28000027	24
22	LOCTITE 242	95000009	
16	FIXED CASTOR 50mm - BLUE	59000003	6

ITEM	DESCRIPTION	PART No.	QNTY
E1	STEERING POT - CONTINOUS ROTATION	X008-022	1
B9	M4x12 POZI PAN HEAD SCREW - BZP	26300057	4
	M4 FLAT WASHER H/DUTY - BZP	28000123	4
	M4 SPRING WASHER TYPE B - BZP	28000018	4
B8	M10 FLAT WASHER H/DUTY - BZP	88300794	6
	M10 SPRING WASHER TYPE B - BZP	28000023	5
B7	M10 HALF NUT LH THREAD 1.25 PITCH - BZP	27000196	1
B6	M10 HALF NUT 1.25 PITCH - BZP	27000195	1
B5	M12 FULL NUT - BZP	27000022	1
	M12 FLAT WASHER H/DUTY - BZP	28000020	1
B4	M10 HALF NUT 1.25 PITCH - BZP	27000195	1
B3	M4x6 DOG HEAD GRUB SCREW - BZP	26300046	1
B2	M10x20 HEX HEAD SET SCREW - BZP	88300792	4
B1	M8x20 HEX HEAD SET SCREW - BZP	88300700	4
	M8 FLAT WASHER H/DUTY - BZP	88300702	4
	M8 SPRING WASHER TYPE B - BZP	28000027	4
	SHAFT EXTENSION	45000281	1
	M6x40 HEX HEAD SET SCREW - BZP	26500434	2
	M6 NYLOC NUT - BZP	27000172	2
19	GREASE - LIGHT	95000019	
18	LOCTITE 242	95000009	1
17	STEERING PILLAR LOWER COVER PLATE	45000280	1
16	UNIVERSAL JOINT NP-18-NOA-02	45000271	1
15	CONNECTING SHAFT TRANSMISSION GEAR	45000278	1
14	LOWER ROD EYE - BL10BDL	45000277	1
13	UPPER ROD EYE - BL10BD	45000276	1
12	DELIN BUSH - SMALL	45000279	2
11	DELIN BUSH - LARGE	45000270	2
10	WOODRUFF KEY 6x6x18	45000282	1
9	CONNECTING SHAFT	45000275	1
8	STEERING POTENTIOMETER GEAR	45000274	1
7	KEYED WASHER	45000273	1
6	SUS 430 KEYED WASHER	45000272	1
5	SUS430 WASHER	45000269	3
4	STEERING POTENTIOMETER LOCATING BRKT	45000268	1

FIX TO MAIN FRAME
USING 2xM10 FLAT
WASHER
1xM10 SAFETY
WASHER
AND 1xM10 HALF NUT
(AS PER OTHER END)

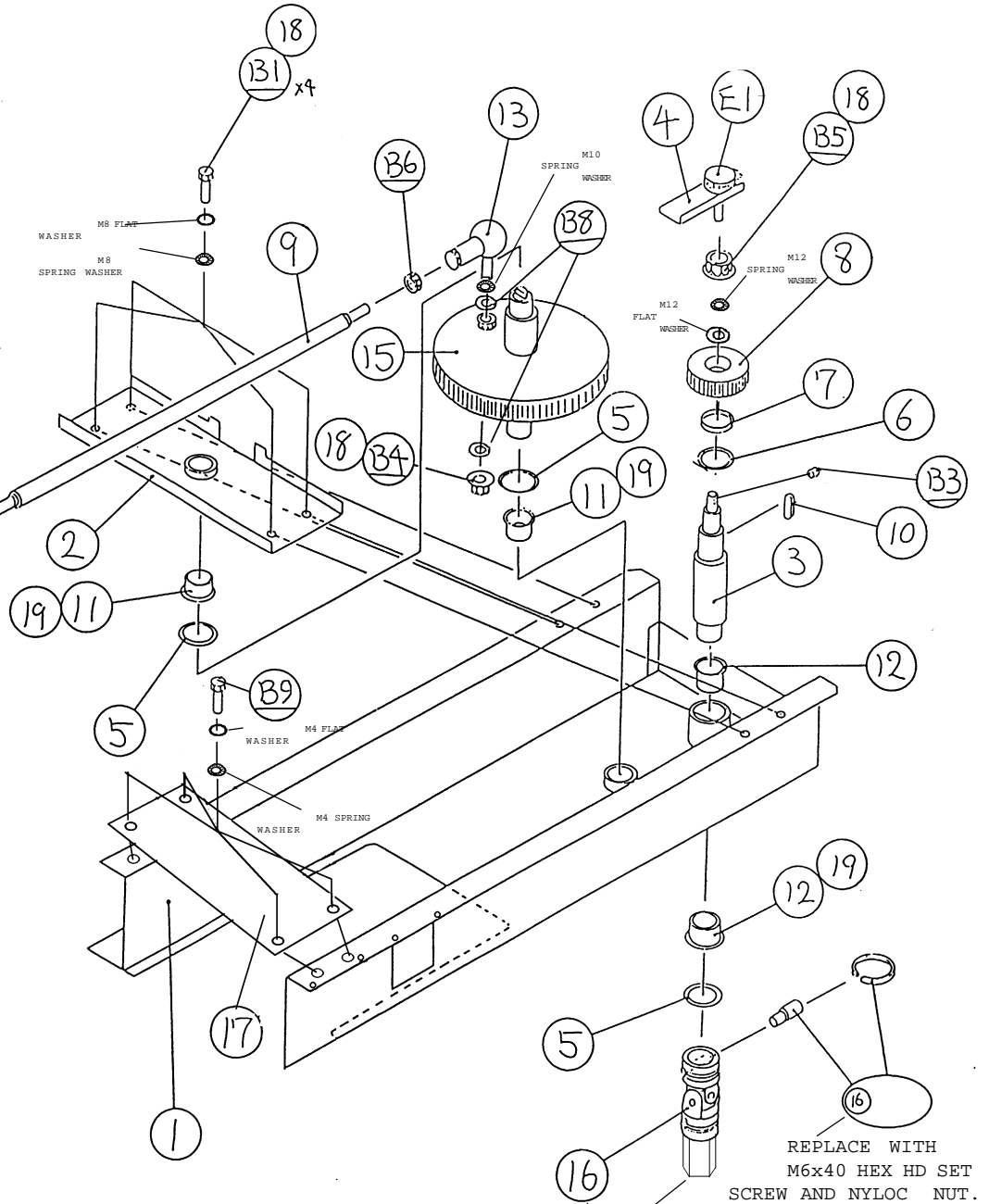

SHAFT

EXTEN-
SION

REPLACE WITH
M6x40 HEX HD SET
SCREW AND NYLOC
NUT.

ITEM	DESCRIPTION	PART No.	QNTY
B17	EXTERNAL CIRCLIP 32mm	45000287	1
B6	M8x20 HEX HEAD SET SCREW - BZP	88300700	16
	M8 FLAT WASHER H/DUTY - BZP	88300702	16
	M8 SPRING WASHER TYPE B - BZP	28000027	16
45	GREASE - LIGHT	95000019	
44	LOCTITE 242	95000009	
30	FIXED CASTOR 50mm - BLACK	59000008	4
18	ROLLER	45000284	1
17	CASTOR SPACER	45000285	2
16	WASHER	45000286	1
7	SEAT BED ASSY - INCL. TURNED PART	45000283	1
	EVA FLOOR MAT - GREY	45000336	1
	EVA ADHESIVE	92000030	

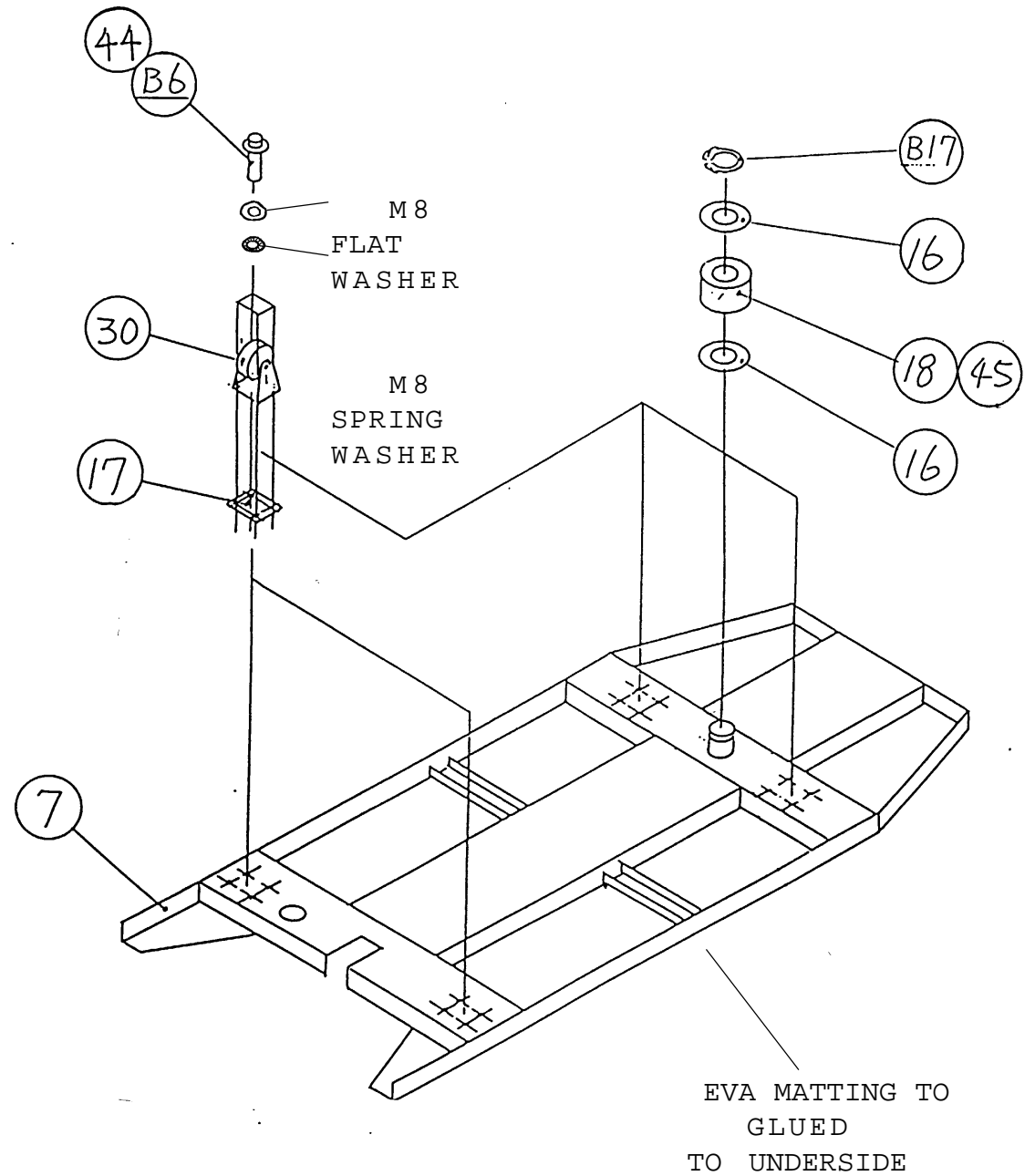

ITEM	DESCRIPTION	PART No.	QNTY
38	LOCTITE 242	95000009	
B9	M10x30 HEX HEAD SET SCREW - BZP	26500428	2
	M10 FLAT WASHER H/DUTY - BZP	88300794	2
	M10 SPRING WASHER TYPE B - BZP	28000023	2
B14	M5x16 HEX HEAD SET SCREW - BZP	26500431	2
	M5 FLAT WASHER H/DUTY - BZP	28000032	2
	M5 SPRING WASHER TYPE B - BZP	28000026	2
B10	M6x16 SECURITY BUTTON HEAD SCREW - SUS	26300044	3
	M6 FLAT WASHER - SUS	88300687	3
	M6 SPRING WASHER TYPE B - SUS	28000012	3
B4	M10x30 HEX HEAD SET SCREW - SUS	88300703	6
	M10 FLAT WASHER - SUS	28000013	6
	M10 SPRING WASHER TYPE B - SUS	28000009	6
B3	M8x35 SECURITY BUTTON HEAD SCREW - SUS	26300040	4
	M8 FLAT WASHER - SUS	28000017	4
	M8 SPRING WASHER TYPE B - SUS	28000017	4
B2	M8x16 HEX HEAD SET SCREW - BZP	88300795	4
	M8 FLAT WASHER H/DUTY - BZP	88300702	4
	M8 SPRING WASHER TYPE B - BZP	28000027	4
B1	M6x16 HEX HEAD SET SCREW - BZP	26500311	8
	M6 FLAT WASHER H/DUTY - BZP	28000037	8
	M6 SPRING WASHER TYPE B - BZP	28000034	8
29	WASHER - BZP	45000347	4
20	STEERING CABINET REINFORCING STRAP PLATE	45000344	2
19	DASHBOARD VAC-FORM LHS MOUNTING BRKT	45000336	1
9	UP/DOWN SHIFTER MOUNTING BRKT	45000335	1
8	DASHBOARD VAC-FORM MOUNTING BRKT	45000334	1
	EVA FLOOR MAT - GREY	45000366	1
	EVA ADHESIVE	92000030	

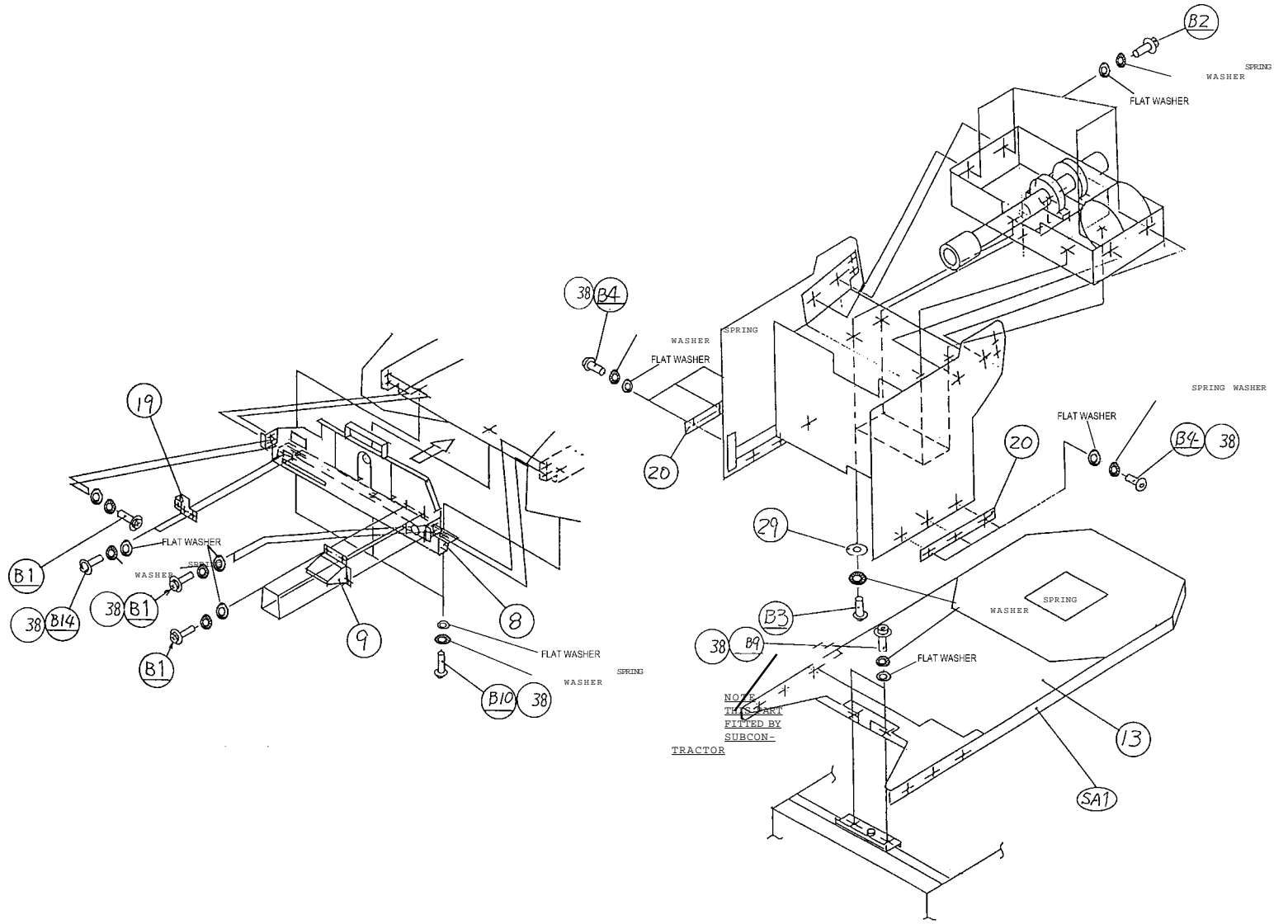

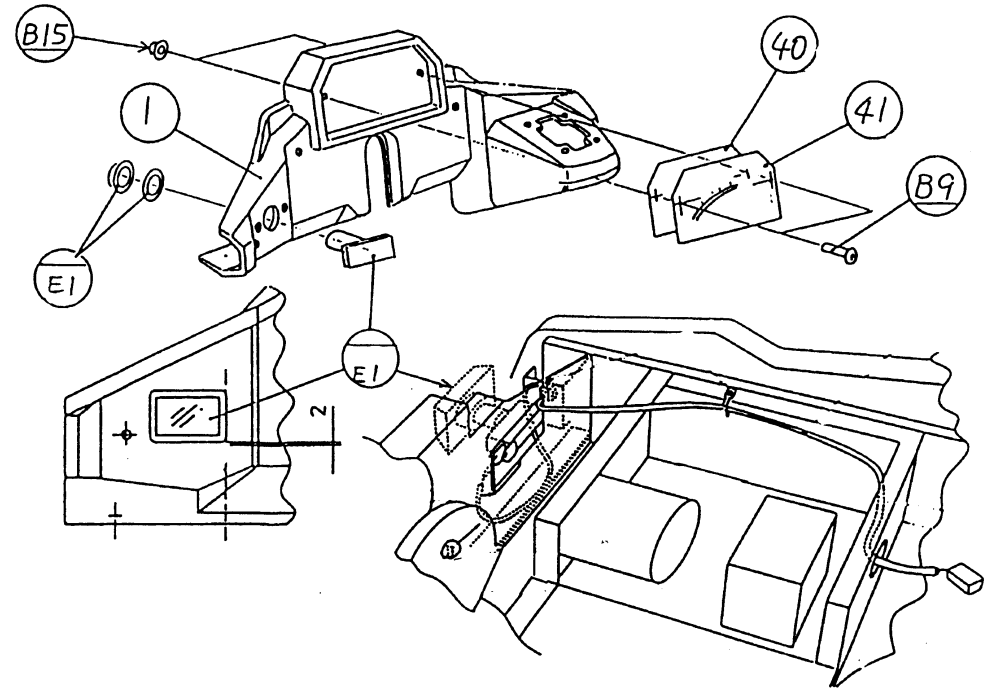
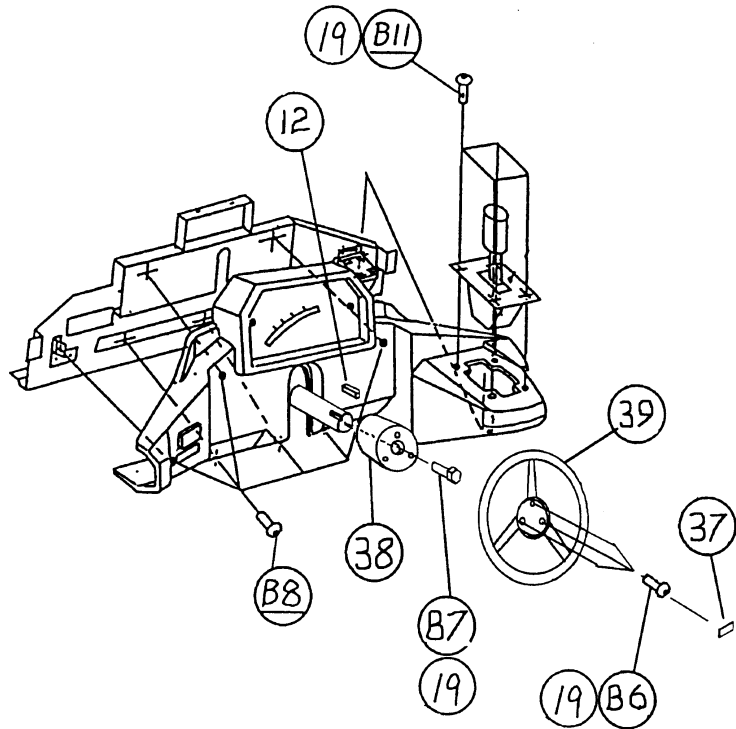

ITEM	DESCRIPTION	PART No.	QNTY
E1	RPB - YELLOW W/VIEWPOINT CHANGE LOGO	60200078	1
B15	M5 WHIZZTITE NUT - BZP	27000151	2
B11	M6x16 SECURITY BUTTON HEAD SCREW - SUS	26300044	4
B9	M5x20 SECURITY BUTTON HEAD SCREW - SUS	26300039	2
B8	M5x12 SECURITY BUTTON HEAD SCREW - SUS	26300045	6
B7	M8x16 HEX HEAD SET SCREW - BZP	88300796	1
	M8 SPRING WASHER TYPE B - BZP	28000027	1
	WASHER 27x10x3	45000349	1
B6	M6x16 SECURITY BUTTON HEAD SCREW - SUS	26300044	3
	M6 SPRING WASHER - SUS	28000012	3
19	LOCTITE 242	95000009	
41	SPEEDO PLEXI - PRINTED	42000005	1
40	SPEEDO BACKING PLEXI	39000049	1
39	STEERING WHEEL - 10" RED LEATHER RACING	88800064	1
38	STEERING WHEEL BOSS	45000342	1
37	"NAMCO LOGO" DECAL	40000022	1
12	WOODRUFF KEY 6x6x31.7	45000318	1
1	DASHBOARD VAC-FORM	45000337	1

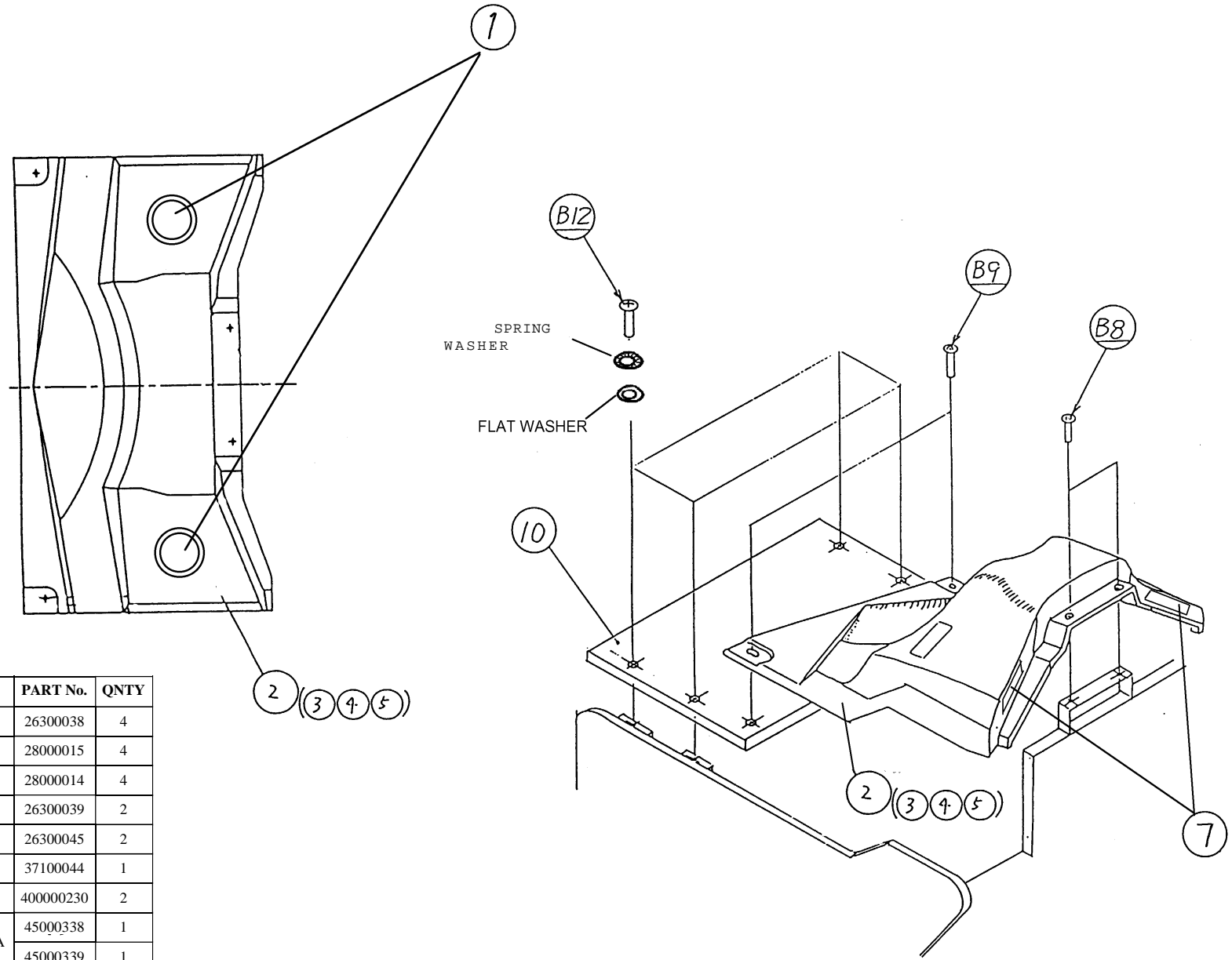

ITEM	DESCRIPTION	PART No.	QNTY
B12	M5x40 SECURITY BUTTON HEAD SCREW - SUS	26300038	4
	M5 FLAT WASHER - SUS	28000015	4
	M5 SPRING WASHER TYPE B - SUS	28000014	4
B9	M5x20 SECURITY BUTTON HEAD SCREW - SUS	26300039	2
B8	M5x12 SECURITY BUTTON HEAD SCREW - SUS	26300045	2
10	STEERING CABINET TOP CLOSING WOOD	37100044	1
7	STOP MOTION DECAL	400000230	2
5	DASHBOARD COVER VAC-FORM - GREEN	A 45000338	1
4	DASHBOARD COVER VAC-FORM - YELLOW		1
3	DASHBOARD COVER VAC-FORM - BLUE	B 45000341	1
2	DASHBOARD COVER VAC-FORM - RED		1
1	MCPB PUSHBUTTON - RED	60200581	2

ITEM	DESCRIPTION	PART No.	QNTY
B16	M20 SPRING WASHER TYPE B - BZP	28000010	1
B15	M20 FLAT WASHER H/DUTY - BZP	28000011	1
B14	M20 FULL NUT - BZP	27000020	1
B7	M5x6 DOG HEAD GRUB SCREW	26300034	1
B6	M4x8 DOG HEAD GRUB SCREW	26300035	1
B4	M6x40 HEX HEAD SET SCREW - BZP	26500434	1
B3	M6 NYLOC NUT - BZP	27000172	1
B2	M6x8 DOG HEAD GRUB SCREW	26300761	4
19	LOCTITE 242	95000009	
17	UNIVERSAL JOINT SHAFT EXTENSION 155mm	45000360	1
16	UNIVERSAL JOINT SHAFT EXTENSION 75mm	45000451	1
15	UNIVERSAL JOINT SHAFT EXTENSION COUPLING	45000361	1
14	STEERING SHAFT GEAR P130-3GT-15-6W	45000355	1
13	PILLOW BEARING BLP-205	45000229	1
12	WOODRUFF KEY 8x7x32	45000363	2
11	SPACER WASHER 9mm	45000452	1
9	UNIVERSAL JOINT NP-18-NOA-02	45000271	1
8	STEERING STOPPER BUMPER	45000359	2
7	STEERING STOPPER	45000358	1
6	KEYED SPACER WASHER	45000357	3
5	STEERING DRIVE SHAFT	45000353	1
3	FLAT SPACER WASHER	45000362	1

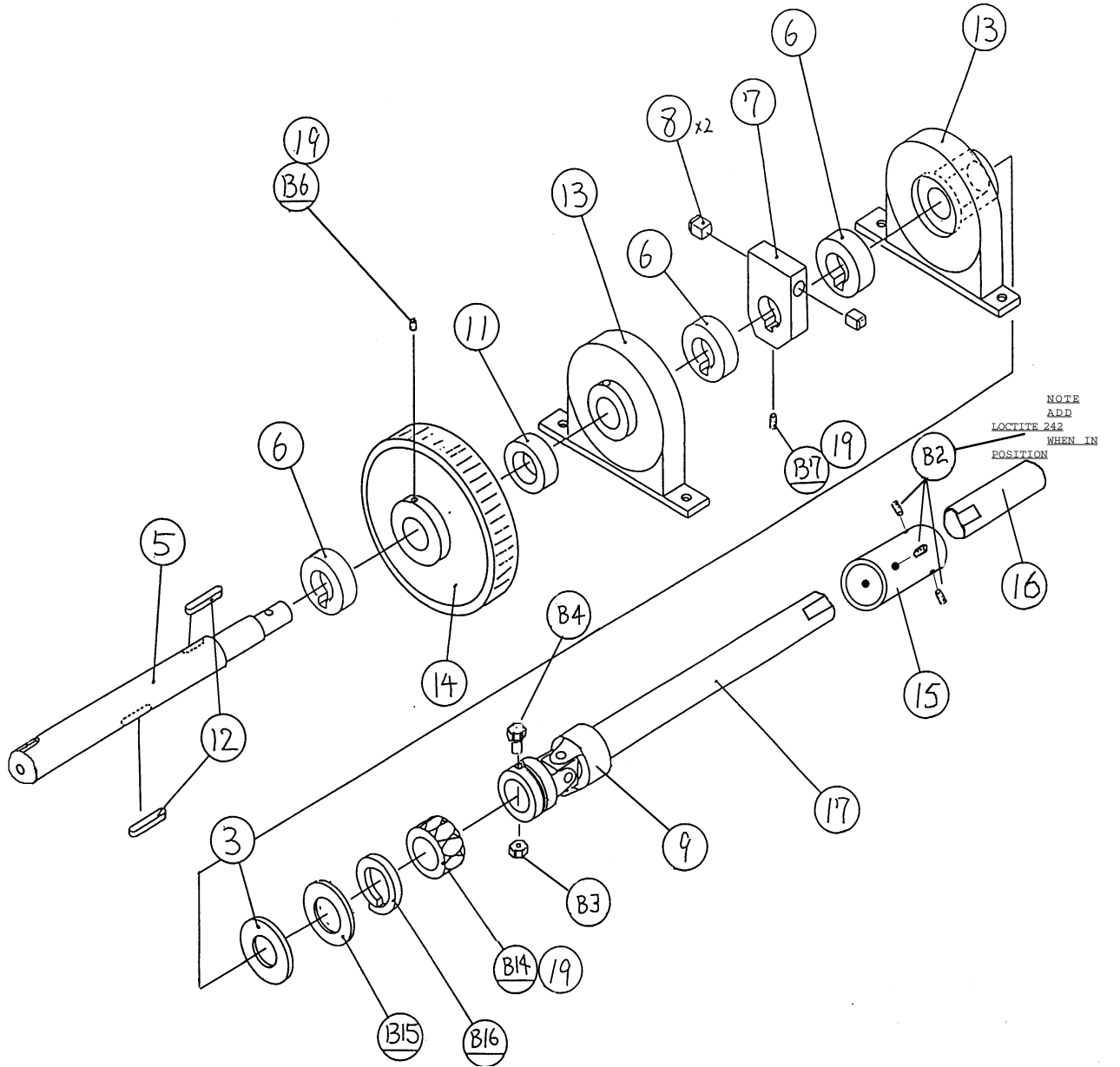

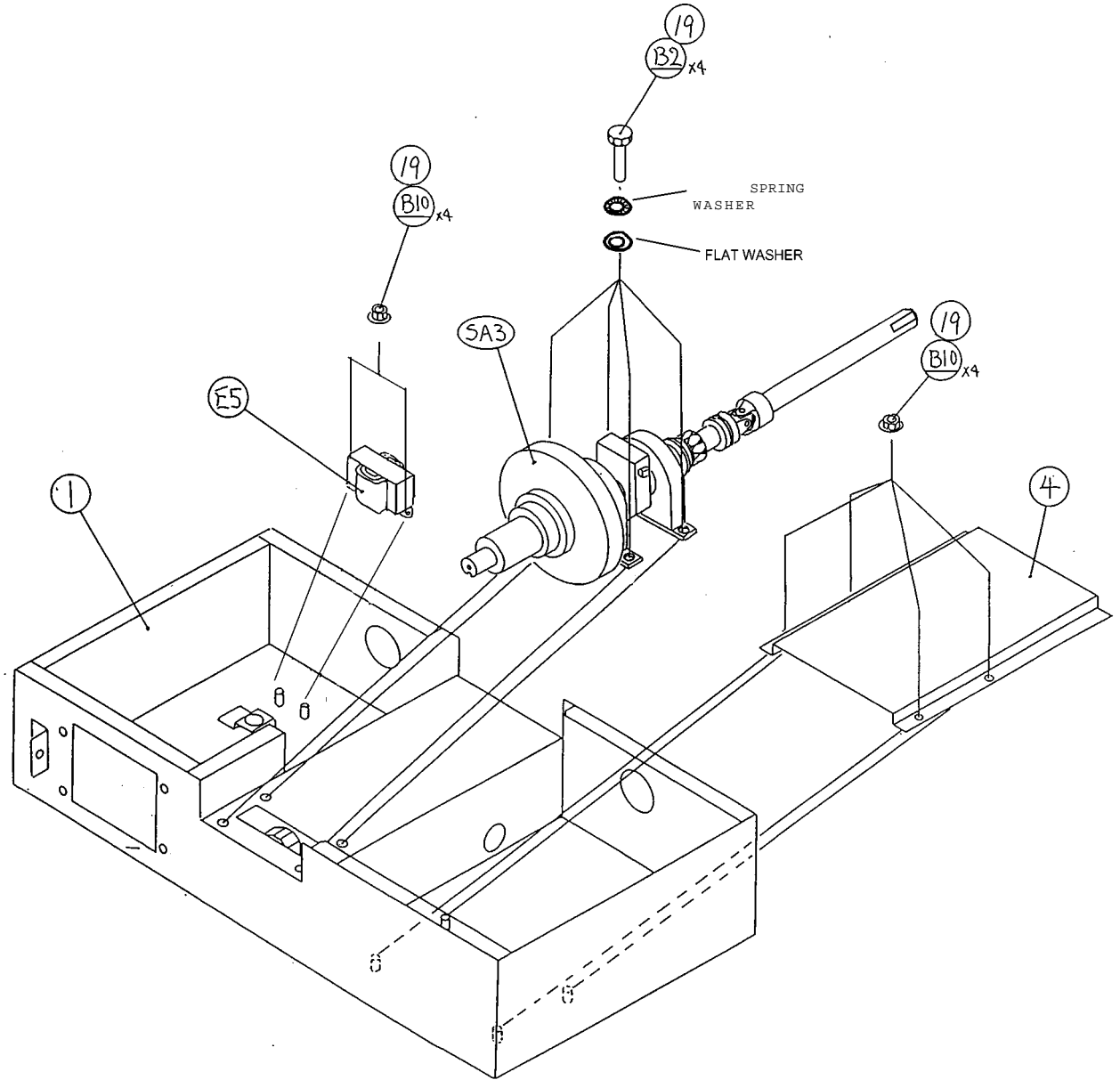

ITEM	DESCRIPTION	PART No.	QNTY
E5	TRANSFORMER 0-220-240 / 15v @ 0.5A - 24v @ 3A	67700031	1
B10	M4 WHIZZTITE NUT - BZP	27000128	6
B2	M8x30 HEX HEAD SET SCREW - BZP	26500407	4
	M8 FLAT WASHER H/DUTY - BZP	88300702	4
	M8 SPRING WASHER TYPE B - BZP	28000027	4
19	LOCTITE 242	95000009	
4	STEERING MOTOR PCB MOUNTING BRACKET	45000352	1
1	STEERING ASSEMBLY TRAY	45000350	1

ITEM	DESCRIPTION	PART No.	QNTY
B12	M6 FULL NUT - BZP	27000021	1
	M6 FLAT WASHER H/DUTY - BZP	28000037	2
B11	M5x12 POZI PAN HEAD SCREW - BZP	26300576	2
	FLAT WASHER H/DUTY - BZP	28000032	2
	SPRING WASHER TYPE B - BZP	28000010	2
B8	M4x8 DOG HEAD GRUB SCREW - BZP	26300035	2
B5	M6x25 HEX HEAD SET SCREW - BZP	26300058	1
B2	M3x10 POZI PAN HEAD SCREW - BZP	26300067	4
	M3 FLAT WASHER - BZP	28000107	4
	M3 SPRING WASHER - BZP	28000109	4
B1	M8x25 HEX HEAD SET SCREW - BZP	26300050	4
	M8 FLAT WASHER H/DUTY - BZP	88300702	4
	M8 SPRING WASHER TYPE B - BZP	28000027	4
E8	20mm PANEL MOUNT FUSE HOLDER	63500785	1
E7	20mm FUSE 5A SLO-BLO	63500600	1
E1	STEERING MOTOR PCB	XAD-STEER PCB	1
E3	STEERING MOTOR 24v DC 15w 500RPM	45000367	1
19	LOCTITE 242	95000009	
16	STEERING DRIVE BELT 597-3M2-15	45000356	1
15	STEERING MOTOR DRIVE PULLEY P26-3GT-15-6F	45000354	1
3	SHORTY BUSHING	39000051	3
2	STEERING MOTOR MOUNTING BRACKET	45000351	1

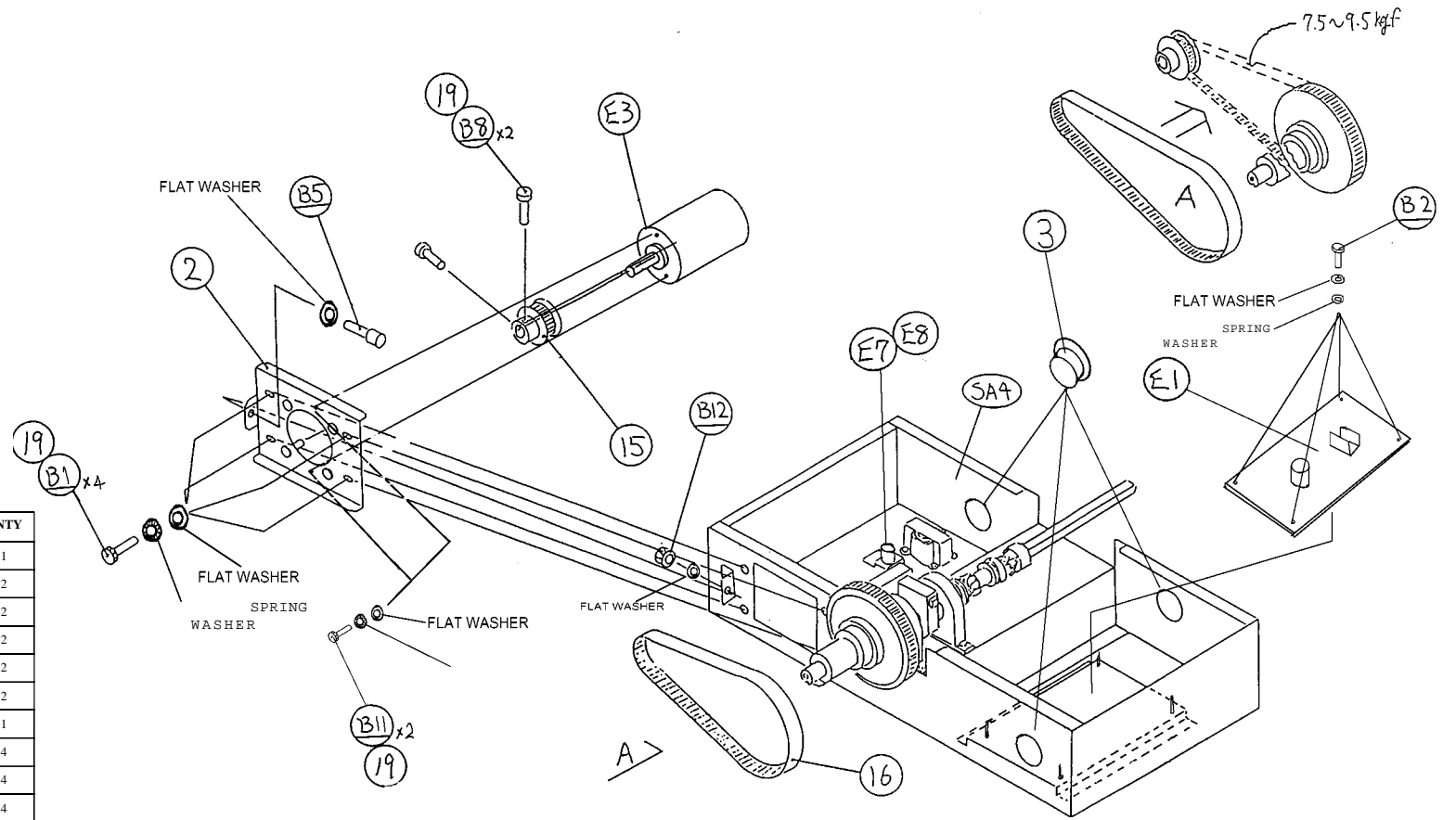

ITEM	DESCRIPTION	PART No.	QNT
B4	M6x40 HEX HEAD SET SCREW - BZP	26500034	4
	FLAT WASHER H/DUTY - BZP	88300791	4
	SPRING WASHER TYPE B - BZP	28000034	4
B3	M4x25 POZI PAN HEAD SCREW - BZP	26300060	4
	M4 FLAT WASHER H/DUTY - BZP	28000036	4
	M4 SPRING WASHER TYPE B - BZP	28000018	4
B2	M8x30 HEX HEAD SET SCREW - BZP	26500407	10
	M8 FLAT WASHER H/DUTY - BZP	88300702	10
	M8 SPRING WASHER TYPE B - BZP	28000027	10
B1	M8x40 CSK SET SCREW - BZP	26300855	4
42	SPEAKER BOX	37100024	1
28	SEAT SUPPORT BRACKET - RHS	45000415	1
25	SEAT ANGLE SUPPORT BRACKET - RHS	45000409	1
24	SEAT ANGLE SUPPORT BRACKET - LHS	45000408	1
20	SEAT REAR WOOD	37100065	1
19	SEAT BASE WOOD	37100064	1
18	SEAT SUPPORT BRACKET - LHS	45000414	1
17	SEAT SUPPORT BRACKET	45000404	1
16	SPEAKER - WOOFER B141	62000062	1
38	LOCTITE 242	95000009	

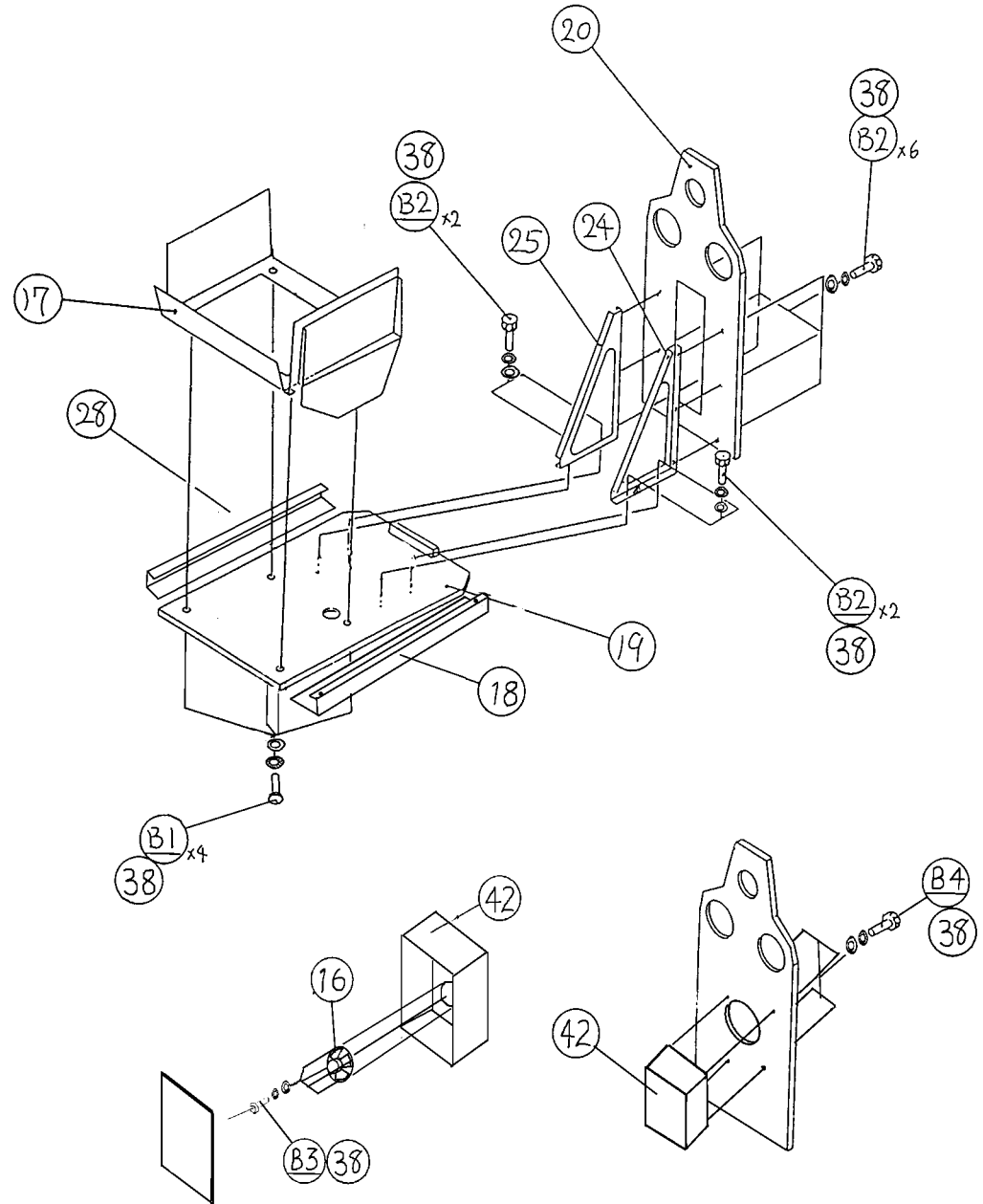

ITEM	DESCRIPTION	PART No	QNT
B7	M8x20 BUTTON HEAD SCREW - BZP	26500119	4
	M8 SPRING WASHER - BZP	28000027	4
B6	M8x40 BUTTON HEAD SCREW - BZP	26500408	4
	M6 FLAT WASHER H/DUTY	88300791	4
	M8 SPRING WASHER - BZP	28000027	4
B5	M5x25 POZI PAN HEAD SCREW - BZP	36300049	12
	M5 FLAT WASHER H/DUTY - BZP	88300789	12
	M5 SPRING WASHER TYPE B - BZP	28000026	12
B4	M4x25 POZI PAN HEAD SCREW - BZP	26300060	16
	M4 FLAT WASHER H/DUTY - BZP	28000036	16
	M4 SPRING WASHER TYPE B - BZP	28000018	16
81	SEAT REAR SUPPORT BRACKET	45000413	1
42	4½" 20w SPEAKER	62000006	2
40	SEAT ADJUST LEVER	45000448	1
39	SEAT RUNNERS (SET)	45000449	1
38	HOSE CLIP	96000021	2
37	CONVOLUTED TUBE	39000050	1
34	CONVOLUTED TUBE TOP VAC-FORM	45000393	1
33	BASS SPEAKER VAC-FORM	45000392	1
31	SPEAKER GRILLE SUPPORT BRACKET	45000410	1
21	HEADREST FRONT SPEAKER GRILLE	45000406	1
18	SEAT FIXING BRACKET	45000405	1
75	LOCTITE 242	95000009	

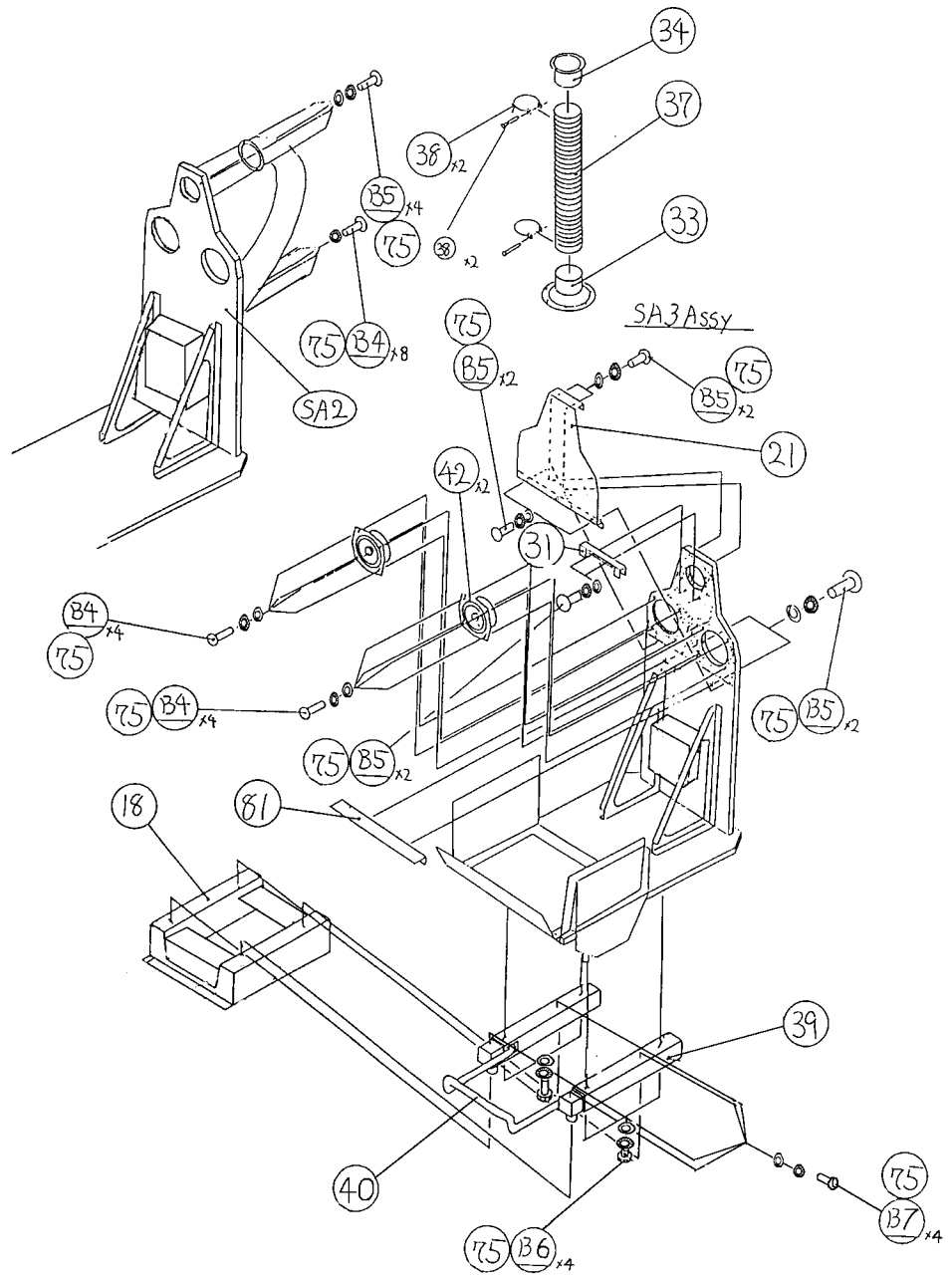

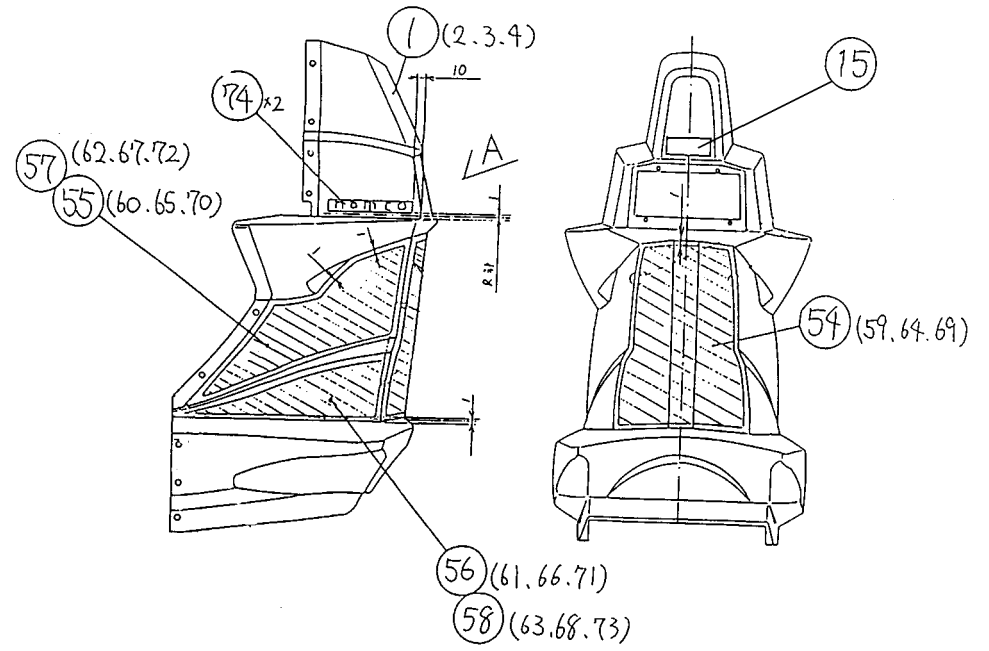
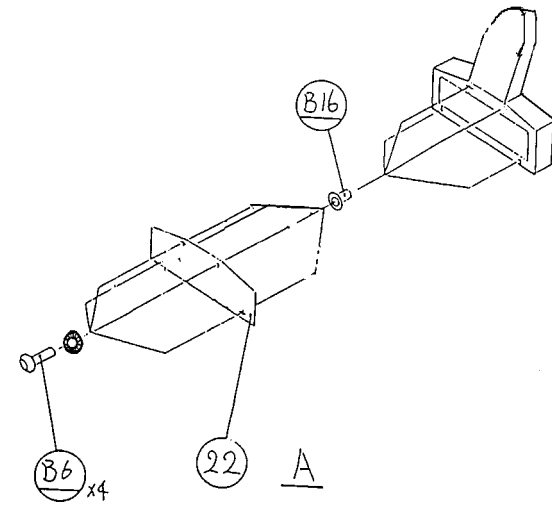

ITEM	DESCRIPTION	PART No	QNTY
B16	M5x14x10 RAWLNUT	27000153	4
B6	M5x25 SECURITY BUTTON HEAD SCREW - SUS	26300033	4
	M5 SPRING WASHER - SUS	28000014	4
74	NAMCO SEAT DECAL	40000066	2
54-73	SEAT DECAL SET - YELLOW	40000067	1
	SEAT DECAL SET - GREEN	40000068	1
	SEAT DECAL SET - RED	40000070	1
	SEAT DECAL SET - BLUE	40000069	1
22	HEAD REST REAR SPEAKER GRILLE	45000407	1
15	SEAT REAR SAFETY DECAL	40000233	1
1-4	SEAT REAR VAC-FORM - YELLOW	45000367	1
	SEAT REAR VAC-FORM - GREEN	45000381	1
	SEAT REAR VAC-FORM - RED	45000389	1
	SEAT REAR VAC-FORM - BLUE	45000385	1

ITEM	DESCRIPTION	PART No	QNTY
B23	M5 WHIZZ NUT	45000418	2
B16	M5x14x10 RAWLNUT	27000153	22
B9	M8x20 HEX HEAD SET SCREW - BZP	88300700	4
	M10 FLAT WASHER H/DUTY - BZP	88300794	4
	M8 SPRING WASHER TYPE B - BZP	28000027	4
B8	M5x25 SECURITY BUTTON HEAD SCREW - SUS	26300033	12
B6	M5x20 SECURITY BUTTON HEAD SCREW - SUS	26300039	16
79	WASHER 15x6 PLASTIC	45000417	12
36	SEAT UNIT	45000394	1
31	WASHER 15x6 - ZINTEC	45000418	2
30	WASHER 15x6 - SUS	45000416	12
	SEAT HEADREST VAC-FORM - YELLOW	45000376	1
	SEAT HEADREST VAC-FORM - GREEN	45000380	1
	SEAT HEADREST VAC-FORM - RED	45000388	1
	SEAT HEADREST VAC-FORM - BLUE	45000384	1
	SEAT LOWER VAC-FORM RHS - YELLOW	45000379	1
	SEAT LOWER VAC-FORM RHS - GREEN	45000383	1
	SEAT LOWER VAC-FORM RHS - RED	45000391	1
	SEAT LOWER VAC-FORM RHS - BLUE	45000387	1
	SEAT LOWER VAC-FORM LHS - YELLOW	45000378	1
	SEAT LOWER VAC-FORM LHS - GREEN	45000382	1
	SEAT LOWER VAC-FORM LHS - RED	45000390	1
	SEAT LOWER VAC-FORM LHS - BLUE	45000386	1
75	LOCTITE 242	95000009	

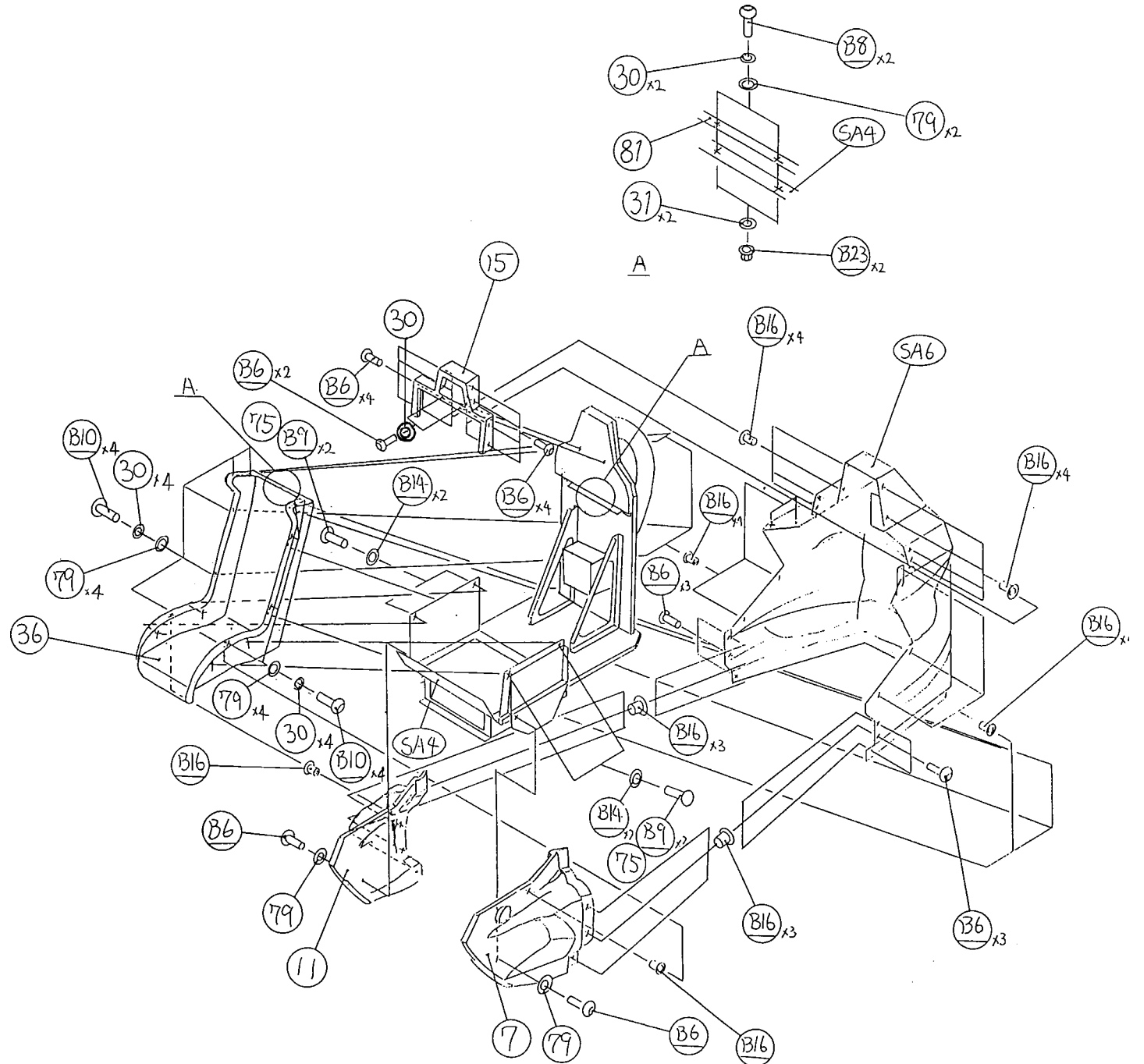

NOTE:
 FIT TO THIS SIDE FOR YELLOW & RED
 FIT TO OTHER SIDE FOR GREEN & BLUE

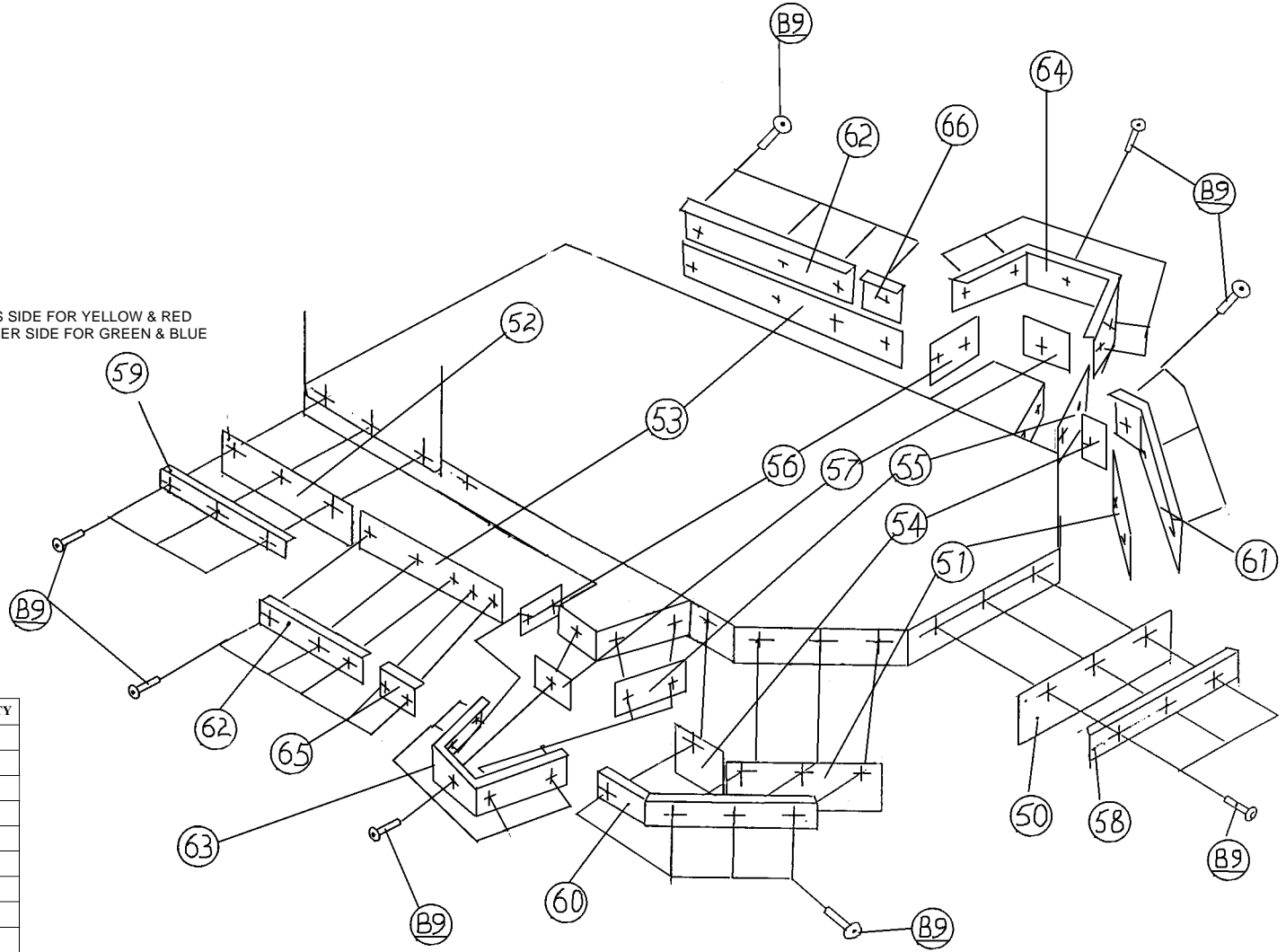

ITEM	DESCRIPTION	PART No	QNTY
B9	M5x16 SECURITY BUTTON HEAD SCREW - SUS	26300032	34
50	SAFETY RUBBER - BACK	45000421	1
51	SAFETY RUBBER - REAR LHS/RHS	45000422	2
52	SAFETY RUBBER - FRONT	45000423	1
53	SAFETY RUBBER - SIDE LHS/RHS - MIDDLE SECTION	45000424	2
54	SAFETY RUBBER - SIDE LHS/RHS - REAR SECTION	45000425	2
55	SAFETY RUBBER - SLIDE COVER BRACKET - REAR	45000426	2
56	SAFETY RUBBER - SLIDE COVER BRACKET - FRONT	45000427	2
57	SAFETY RUBBER - SLIDE COVER BRACKET - OUTSIDE	45000428	2
58	SAFETY RUBBER RETAINING BRACKET - BACK	45000429	1
59	SAFETY RUBBER RETAINING BRACKET - FRONT	45000430	1
60	SAFETY RUBBER RETAINING BRACKET - REAR LHS	45000431	1
61	SAFETY RUBBER RETAINING BRACKET - REAR RHS	45000432	1
62	SAFETY RUBBER RETAINING BRACKET - SUS	45000433	2
63	SAFETY RUBBER RETAINING BRACKET - SLIDE COVER LHS	45000434	1
64	SAFETY RUBBER RETAINING BRACKET - SLIDE COVER RHS	45000435	1
65	SAFETY RUBBER RETAINING BRACKET - SIDE LHS	45000436	1
66	SAFETY RUBBER RETAINING BRACKET - SIDE RHS	45000437	1

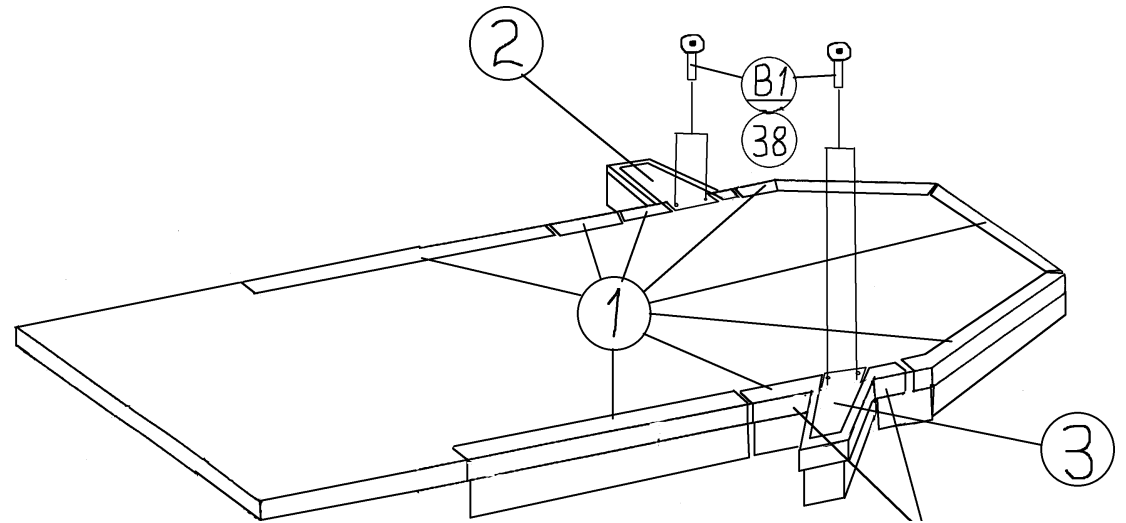

ITEM	DESCRIPTION	PART No
B1	M6x16 SECURITY BUTTON HEAD SCREW - SUS	26300044
B2	M8x16 SECURITY BUTTON HEAD SCREW - SUS	88300795
3	SLIDE COVER BRACKET SAFETY DECAL - LHS	40000226
2	SLIDE COVER BRACKET SAFETY DECAL - RHS	40000227
1	SAFETY DECAL STRIP - YELLOW/BLACK	40000224
38	LOCTITE 242	95000009

ITEM	DESCRIPTION	PART No	QNTY
B23	M8x20 HEX HEAD SET SCREW - BZP	88300700	4
	M8 FLAT WASHER - BZP	88300702	4
	M8 SPRING WASHER - BZP	28000176	4
B13	M5 WHIZZTITE NUT	27000151	8
B5	M5x12 PZ CSK SCREW - SUS	26300069	8
B4	M5x12 SECURITY BUTTON HEAD SCREW - SUS	26300045	34
35	REAR BASE COVER PLATE DECAL - RHS	40000075	1
34	REAR BASE COVER PLATE DECAL - LHS	40000074	1
33	FRONT BASE COVER PLATE DECAL - LHS/RHS	40000073	2
21	SUS CASTOR ROLLER PLATE	45000248	2
20	SHIPPING BRACKET - REAR	45000264	2
19	BASE REAR "NAMCO" DECAL	40000071	1
18	BASE "FORK HERE" DECAL	40000072	4
17	SERIAL NUMBER PLATE	-----	1
16	RIVET 3.2 x 9.5	23000010	4
15	MOTOR EMERGENCY STOP DECAL	40000225	1
10	SIDE STEP PLATE	45000375	2
5	REAR BASE COVER PLATE - RHS	45000374	1
4	REAR BASE COVER PLATE - LHS	45000373	1
3	FRONT BASE COVER PLATE - RHS	45000372	1
2	FRONT BASE COVER PLATE - LHS	45000371	1
38	LOCTITE 242	95000009	--

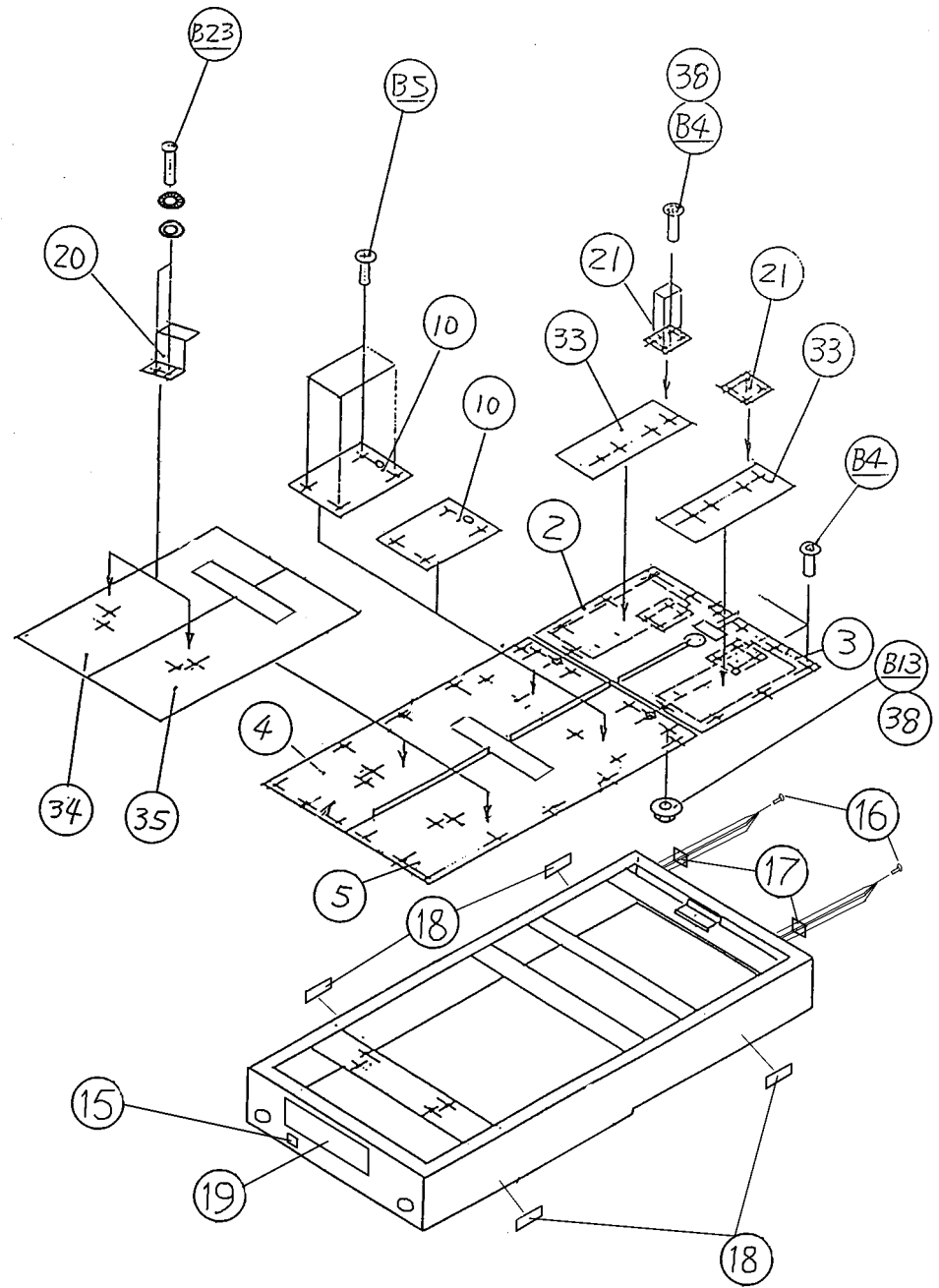

NOTE:
 FIT TO THIS SIDE FOR YELLOW & RED
 FIT TO OTHER SIDE FOR GREEN & BLUE

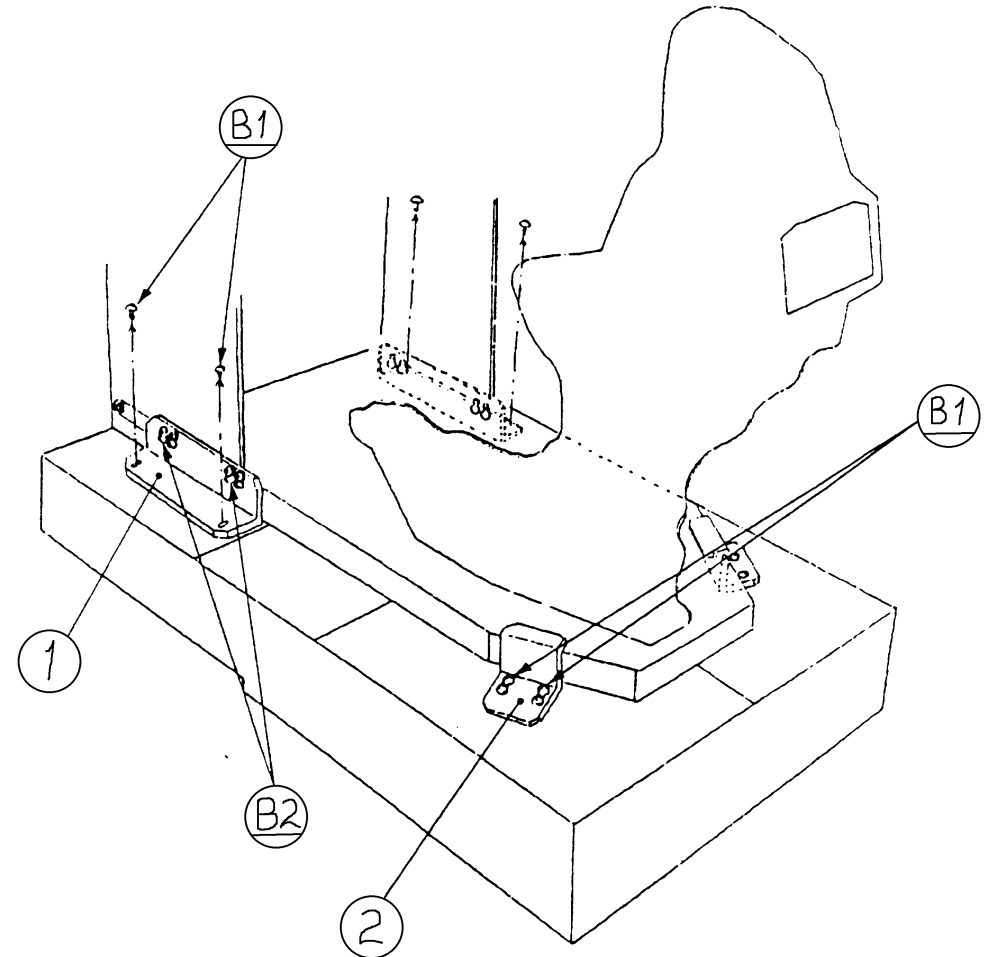

ITEM	DESCRIPTION	PART No
B1	M8x20 HEX HEAD SET SCREW - BZP	88300700
B2	M10x30 HEX HEAD SET SCREW - SUS	88300703
	M10FLAT WASHER - SUS	28000013
	M10 SPRING WASHER TYPE B - SUS	28000009
2	REAR SHIPPING BRACKET	45000264
1	FRONT SHIPPING BRACKET	45000369

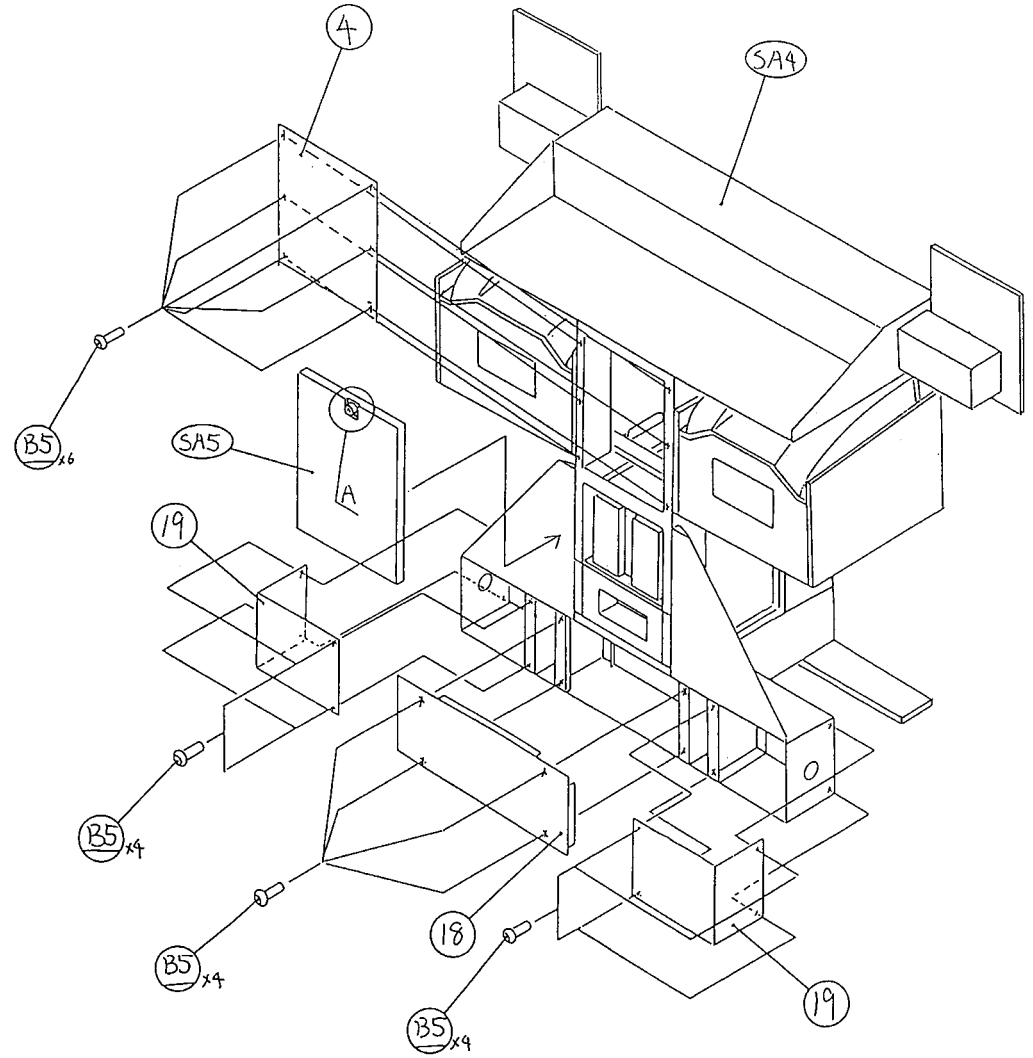
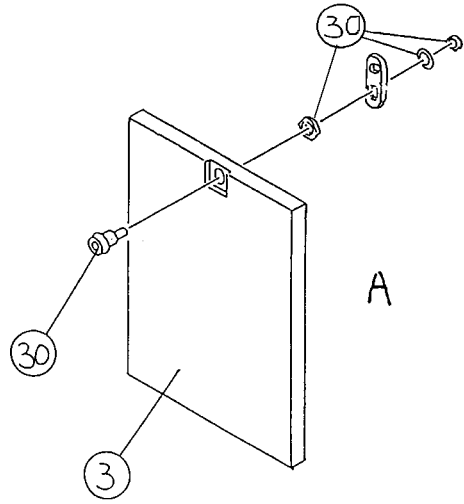

ITEM	DESCRIPTION	PART No	QN
B5	M5x12 SECURITY BUTTON HEAD SCREW - SUS	26300045	1
30	LOCK	24000016	1
19	TOWER PLINTH REAR CLOSING PLATE - LHS/RHS	45000304	2
18	TOWER PLINTH REAR CENTRE CLOSING PLATE	45000303	1
4	UPPER BACK DOOR	45000291	1
3	PCB SECTION REAR DOOR	45000220	1

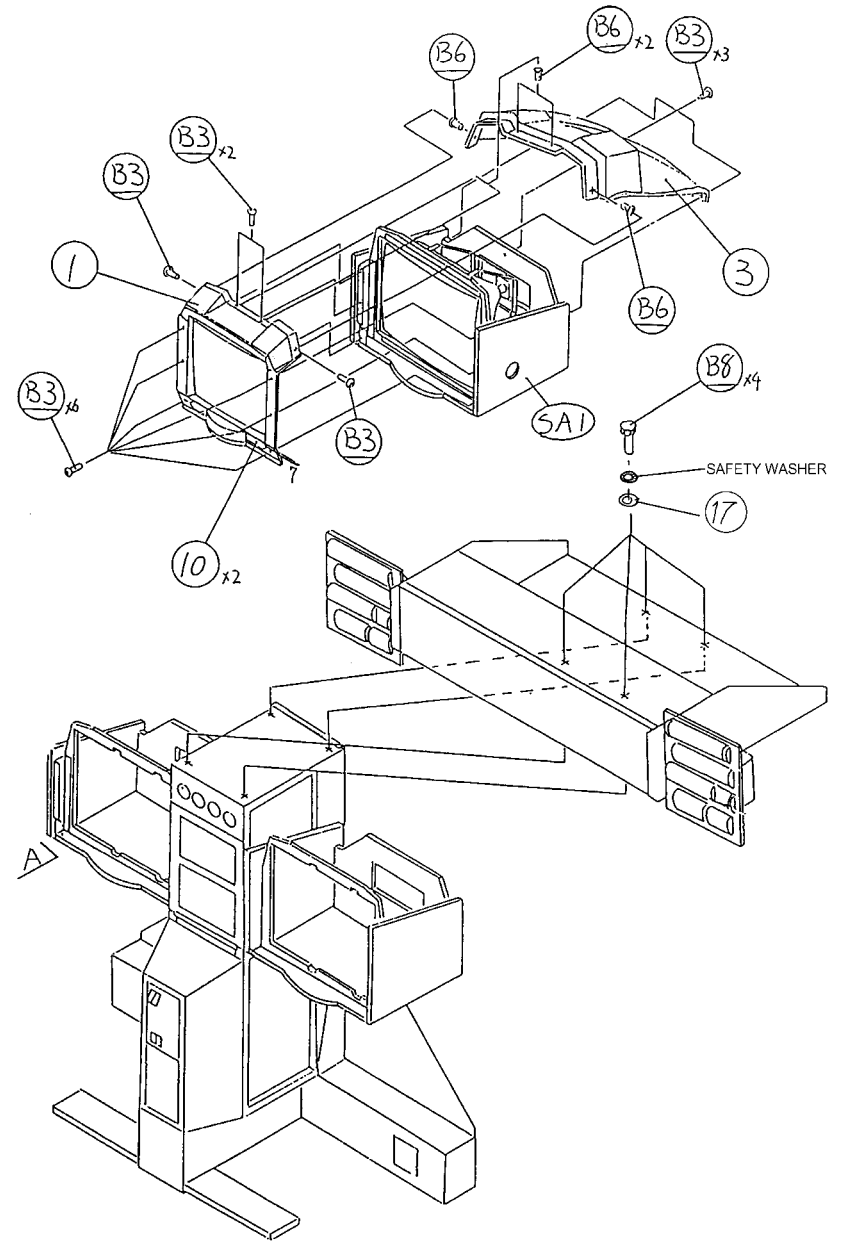
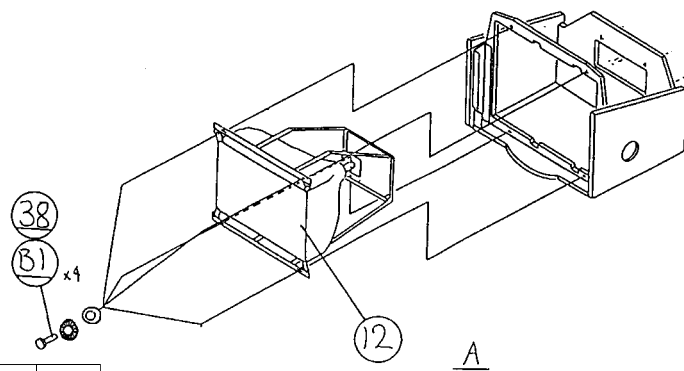

ITEM	DESCRIPTION	PART NO	QNTY
17	WASHER - BZP	45000364	4
B8	M10x30 HEX HEAD SET SCREW - BZP	26500428	4
	M10 SPRING WASHER TYPE B - BZP	28000023	4
B6	M5 RAWLNUT	27000153	8
B3	M5x20 SECURITY BUTTON HEAD SCREWS - SUS	26300039	26
B1	M6x40 HEX HEAD SET SCREW - BZP	26500434	8
	FLAT WASHER 1/4"x1" - BZP	28000040	8
	SPRING WASHER TYPE B - BZP	28000034	8
12	HANTAREX 33" POLO MONITOR W/REMOTE		2
10	DECAL - MONITOR VAC-FORM	40000209	4
3	MONITOR TOP VAC-FORM - YELLOW	A 45000316	1
	MONITOR TOP VAC-FORM - GREEN	45000317	1
	MONITOR TOP VAC-FORM - BLUE	B 45000318	1
	MONITOR TOP VAC-FORM - RED	45000319	1
1	TUBE SURROUND VAC-FORM	45000315	2
38	LOCTITE 242	95000009	

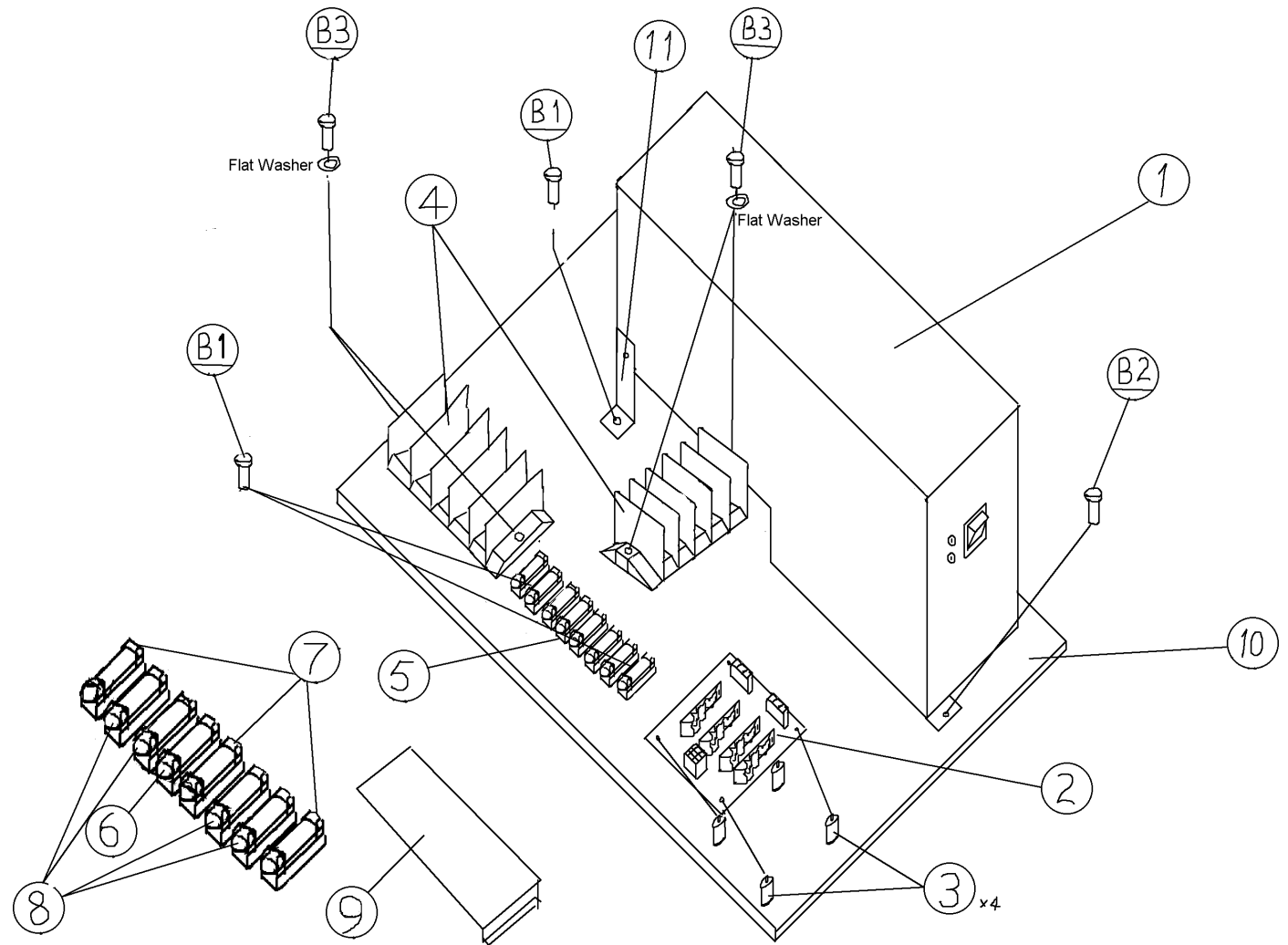
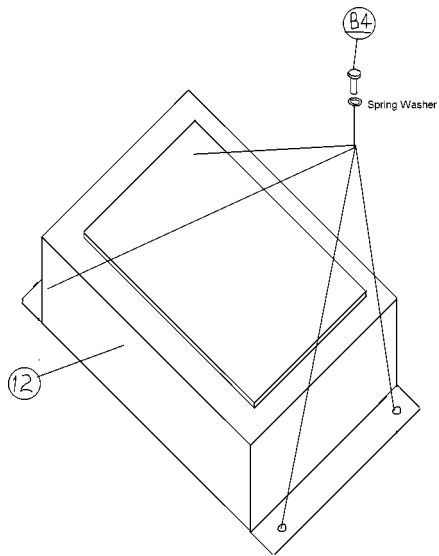

ITEM	DESCRIPTION	PART No	QNTY
B4	M4x20 POZI PAN HEAD SCREW - BZP	26300055	4
	M4 SPRING WASHER	28000018	4
B3	M4x25 POZI PAN HEAD SCREW - BZP	26300060	4
	M4 FLAT WASHER - BZP	28000036	4
B2	M4x20 POZI PAN HEAD SCREW - BZP	26300055	1
	M4 SPRING WASHER - BZP	28000035	1
B1	No6x½" POZI FLANGE HEAD SCREW - BZP	26100169	4
12	AMPLIFIER ASSEMBLY	45000314	1
11	SMPSU MOUNTING BRACKET	88300613	1
10	PSU WOOD	37100062	1
9	FUSE COVER STRIP	-----	1
8	FUSE ¼" 1A SLO-BLO	63500639	4
7	FUSE ¼" 2A SLO-BLO	63500506	3
6	FUSE ¼" 3A SLO-BLO	63500547	1
5	FUSE STRIP 8way	63500046	1
4	ELKAY 5way TERM BLOCK	66000014	2
3	PCB MOUNTING PILLAR	39000040	4
2	LAMP DRIVER PCB	45000402	1
1	SMPSU 5v 30A / 12v 5A	83000004	1

TOWER ASSEMBLY

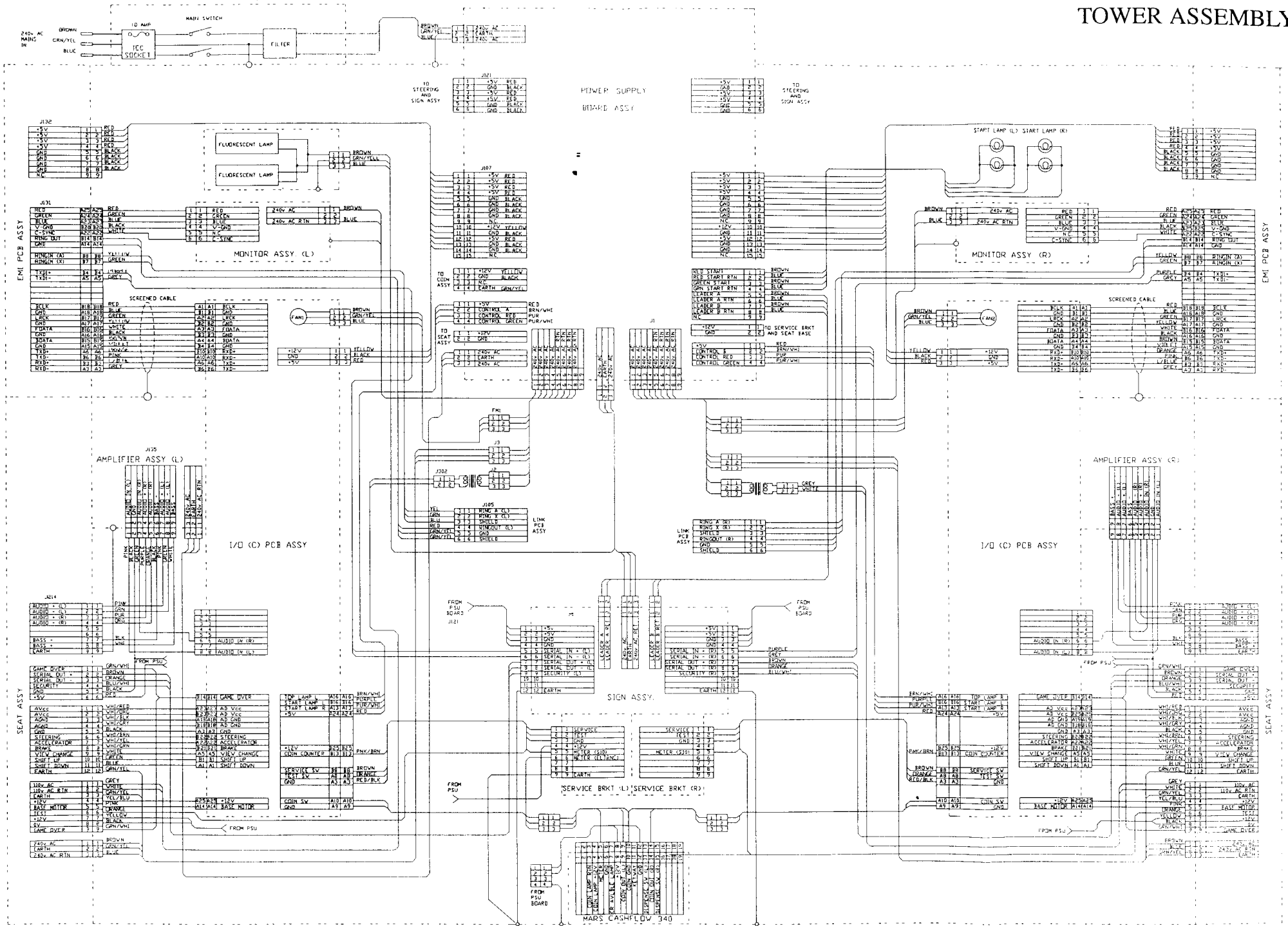

SEAT ASSEMBLY

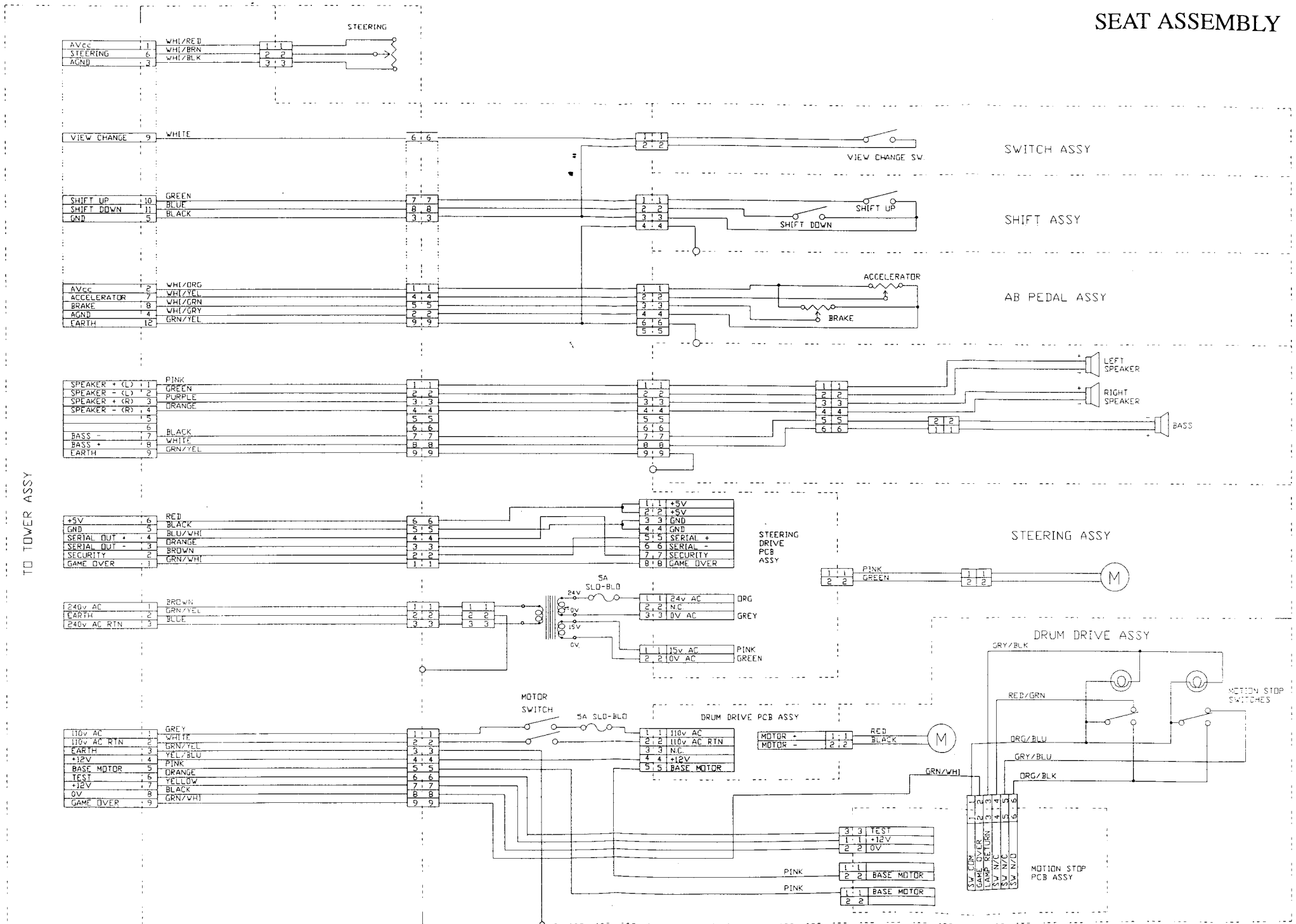

TO TOWER ASSY

POWER SUPPLY BOARD

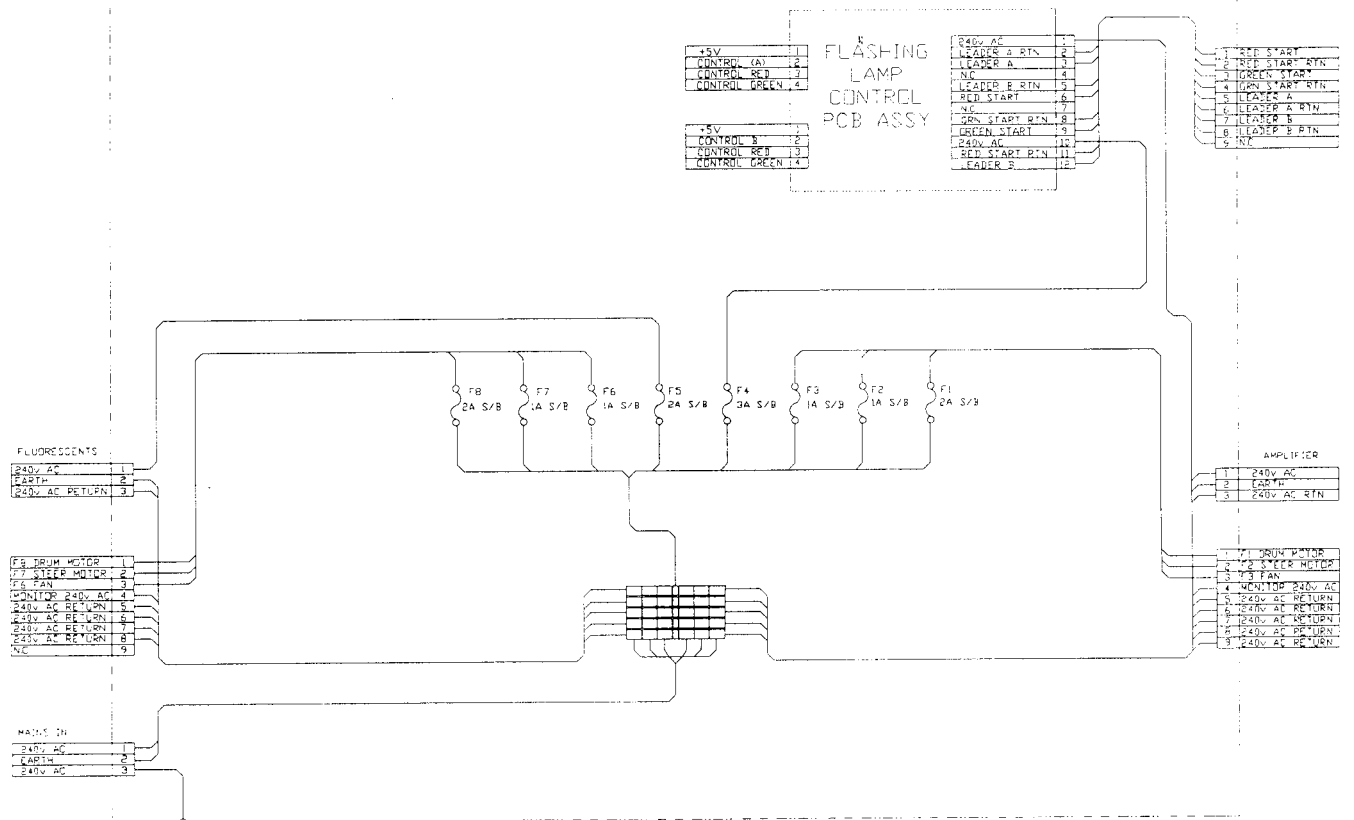
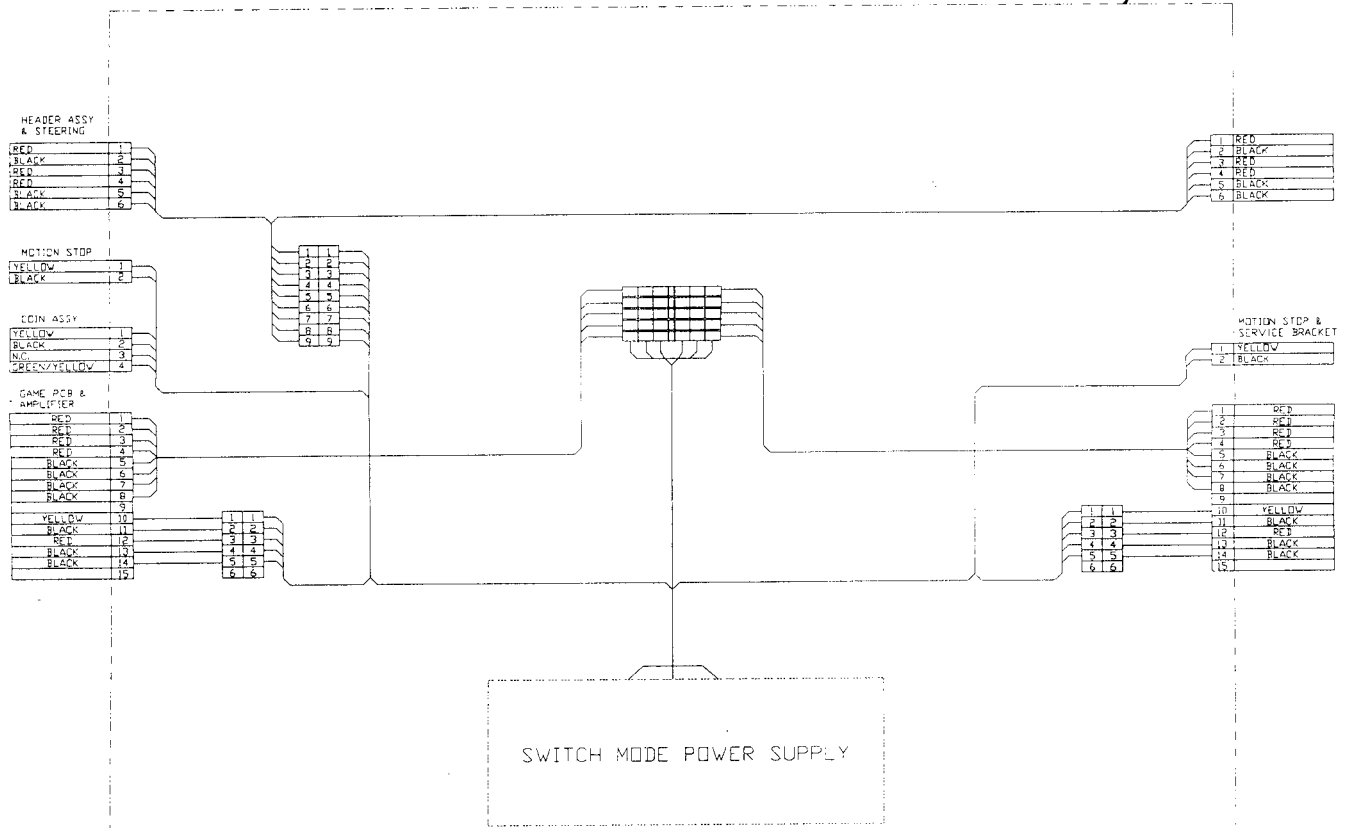

SERVICE BRACKET ASSY

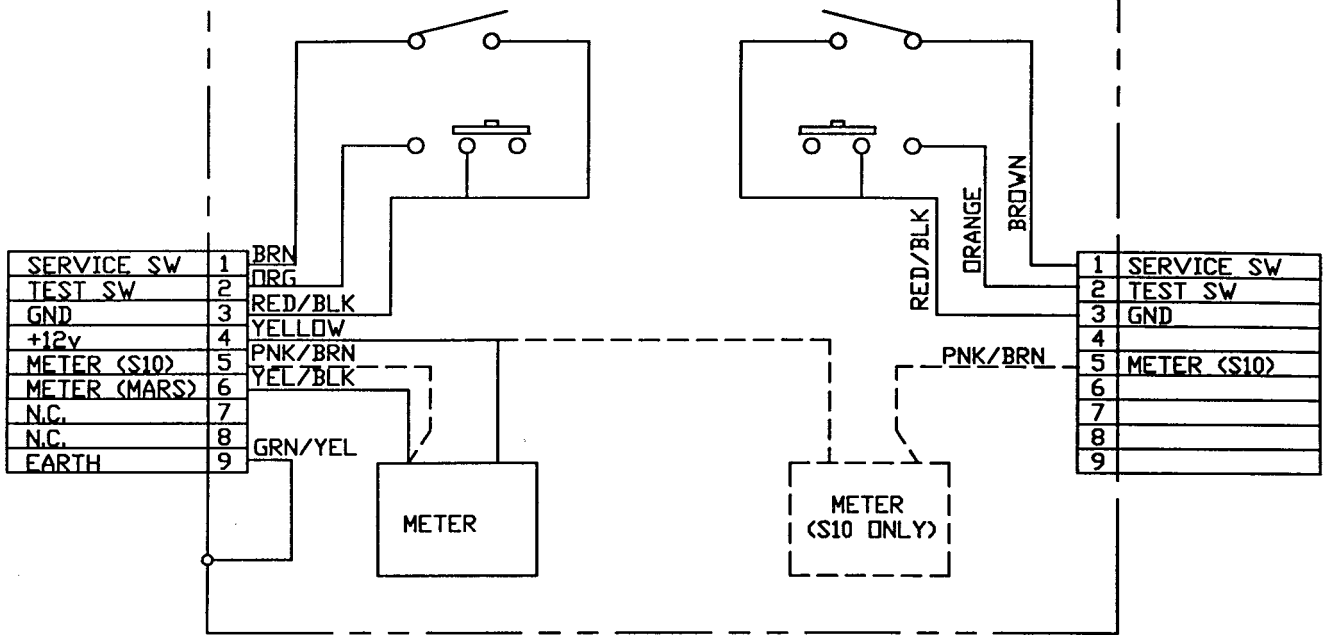

COIN DOOR ASSY

