

**namco<sup>®</sup>**



# **GODZILLA WARS Jr.**

## **Operators Manual**

**1. SPECIFICATIONS**

**POWER SUPPLY :-** 220/240 Volts AC

**CAPSULE SIZE :-** 50mm DIAMETER

or

**C2000 TICKET DISPENSER**

**DIMENSIONS :-** 645(w) x 745(d) x 1665(h) (with header)

**WEIGHT:-** 77kg.

**ACCESSORIES:-**

Keys:	(Cash Door) .....	2
	(Coin Door) .....	2
	(Back Door) .....	2
	(Hopper Door) or (Dispenser Door) .....	2
	Operators Manual .....	1

## **2. PRECAUTIONS**

### **2-1 Cautions When Installing.**

This game is designed for indoor use only. The game must not be installed outdoors or under the following conditions:-

- a. In areas directly exposed to sunlight, high humidity, direct water contact, dust, high heat or extreme cold.
- b. In locations that would present an obstacle in the case of an emergency, i.e. near fire equipment or emergency exits.
- c. On an unstable surface or subject to floor vibration.

### **2-2 Caution When Handling.**

- a. AC power must always be turned OFF, and the game disconnected, before replacing any parts or connecting/disconnecting connectors.
- b. When unplugging the game from an electrical outlet, always grasp the plug, not the mains lead.
- c. The machine must be earthed with a securely connected earthed plug.
- d. Care must be taken at all times to avoid electric shock when inspecting or adjusting the game.

### **2-3 When Transporting.**

- a. Do not subject the game to physical shock when transporting or moving it.
- b. Take care not to rope any plastic parts when transporting.

## **3. INSTALLATION**

1. Ensure that five ping-pong balls have been placed on the playfield, and the hopper filled with capsules or the ticket dispenser loaded with tickets.

## 4. HOW TO PLAY

1. Insert coin/s to establish credit, shown on the credit display, then press the dispense button once. Godzilla will begin to move and the background sounds will begin.
2. Pressing the bomb pushbutton when lit will fire a ping-pong ball at Godzilla. If the timing is right the ball will go into Godzilla's mouth.
3. If six balls are shot into Godzilla's mouth in the given time, Godzilla is defeated and a prize or tickets will be dispensed.
4. The game is over if the player fails to shoot six balls into Godzilla's mouth in the given time.

## 5. ADJUSTMENTS

### 5-1. DIP Switch Settings

The DIP switches on the game PCB alter the price of play, game difficulty and ticket/prize mode.

*Note;- This machine is fitted with a credit dispense board, and the game PCB switches should always be set for 1 coin 1 play and game pricing set using the credit dispense board switches.*

**Always turn the machine OFF when adjusting DIP switches.**

Function		1	2	3	4	5	6	7	8
Coin	<b>1 coin - 1 play</b>	<b>ON</b>	<b>ON</b>	<b>ON</b>					
	1 coin - 2 plays	off	on	on					
	1 coin - 3 plays	on	off	on					
	2 coins - 1 play	off	off	on					
	2 coins - 3 plays	on	on	off					
	3 coins - 1 play	off	on	off					
	3 coins - 2 plays	on	off	off					
	Free play	off	off	off					
Number of tickets issued	2 tickets for each point +10 tickets for 6 points				<b>ON</b>				
	3 tickets for each point +10 tickets for 6 points				off				
Difficulty	Hard					on	on		
	Medium					<b>OFF</b>	<b>ON</b>		
	Easy					on	off		
	Very Easy					off	off		
Off = hopper mode / On= ticket mode								<b>OFF</b>	
Sound in attract mode	Yes								<b>ON</b>
	No								off

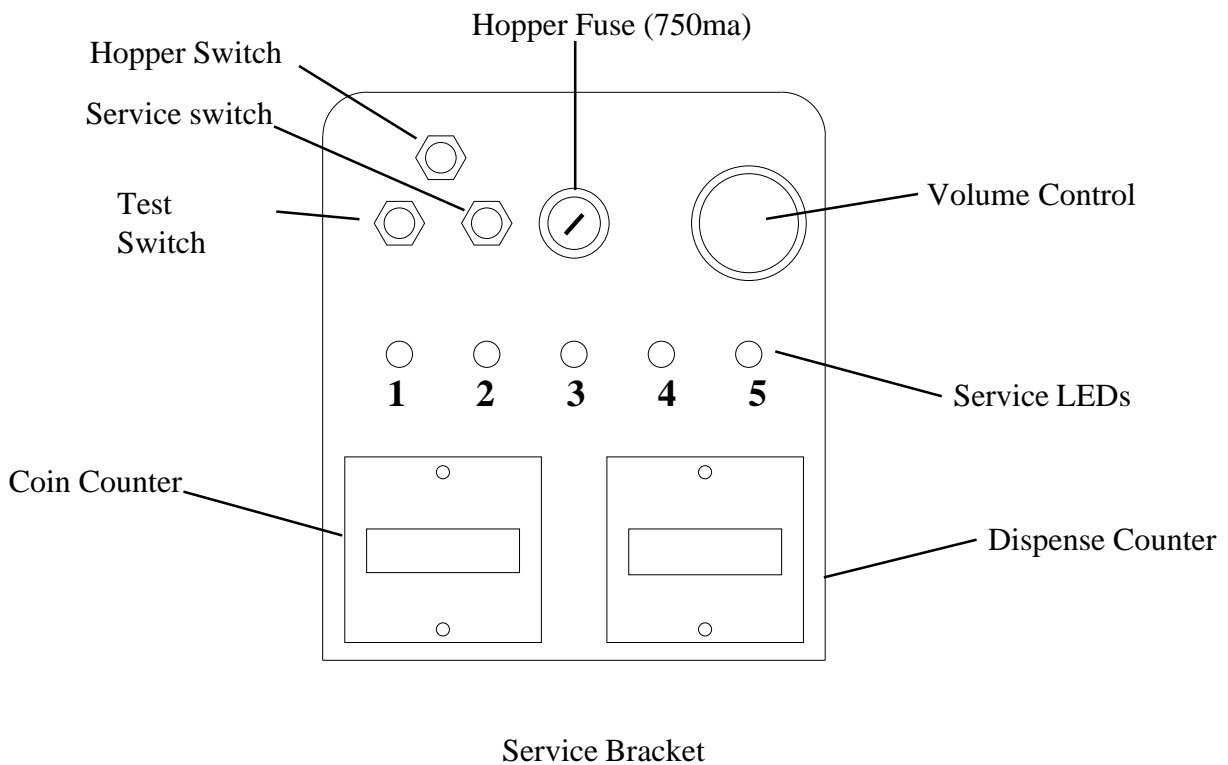

## 5-2. Volume Control

The volume control is fitted to the service bracket located inside the coin door.

## 5-3. Service Switch

Pressing the service switch establishes a game credit without operating the coin counter.

## 5-4. Hopper Switch

If the hopper switch is pressed while the machine is in stand-by, the hopper will turn and a capsule dispensed.

## 5-5. Test Switch

There are seven test steps. The steps are advanced each time the test switch is pressed.

### Test 1 Mouth Motor Test

The mouth motor runs and count lamps 2 or 5 light when Optos 1 or 2 are interrupted, and ping pong balls can be fired by pressing the bomb button.

### Test 2 Godzilla Motor Test

Godzilla motor operates and count lamp 4 lights when Opto 3 is interrupted

Test 3 Ball Shooting Test

The mouth opens and balls are automatically shot. The height to which balls are shot can be adjusted during this test. (see 5-6 below)

Test 4 Sound Test

All the game sounds are produced one after another.

Test 5 Lamp and LED test

The count lamps light one after another. The game over and hit lamps flicker alternately. The bomb button lamp and service LEDs light every other second.

Test 6 Switch Test

A bleep will sound each time the bomb button, hopper switch, service switch, Godzilla's mouth microswitch or hopper outlet microswitch is pressed.

Pressing the test switch again will put the machine back to stand-by mode.

### 5-6. Ball Height Adjustment

The height to which the balls are fired can be adjusted by loosening (do not remove) the two screws fixing the spring retaining plate on the side of the ball shooter assy and moving the plate up or down. Ensure that the two screws are fully tightened when adjustment is completed.

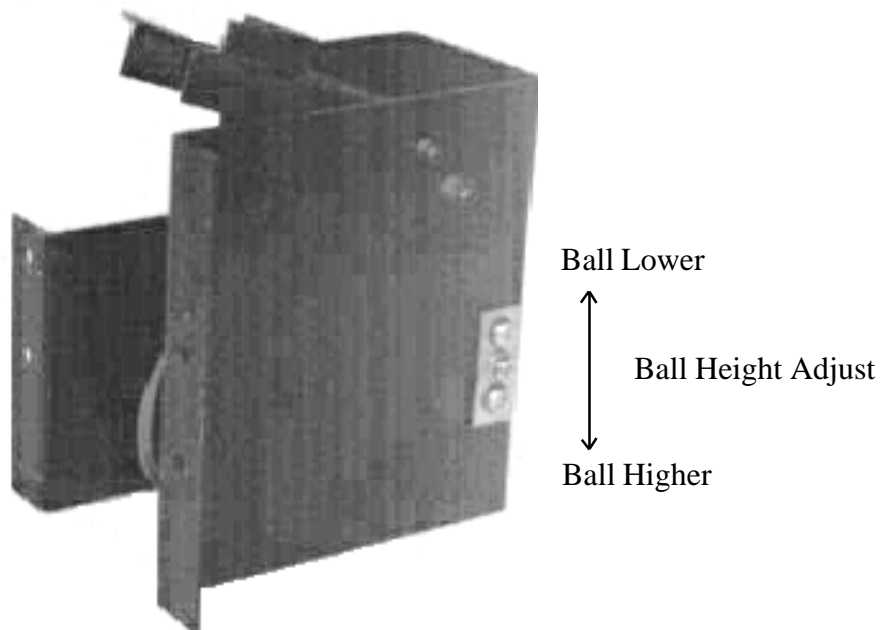

## 6. TROUBLESHOOTING

The game constantly monitors certain functions and if there is a failure certain LEDs or count lamps light as an indication.

The following table indicates these conditions.

Service LED Indication	Fault Indicated
○ ○ ● ○ ●	Credit dispense pulse remains on
○ ○ ● ● ○	
● ○ ○ ● ○	Service switch remains on
○ ● ● ○ ○	Mouth micro switch remains on
● ○ ● ○ ●	Hopper test switch remains on
● ○ ○ ○ ●	Hopper microswitch remains on
● ○ ● ○ ○	Hopper not dispensed
○ ● ○ ○ ○	Tickets run out
● ○ ● ● ○	Ticket count switch remains on
○ ● ○ ● ○	Test switch remains on
● ● ● ○ ●	Opto 3 remains on
● ● ○ ● ●	Opto 2 remains on
● ○ ● ● ●	Opto 1 remains on
● ○ ○ ● ●	Mouth motor not working
Count Lamp Indication	Fault Indicated
○ ● ○ ● ○ ○	Mouth does not return to start position at power-up
● ○ ○ ○ ● ○	Godzilla does not return to start position at power-up

○ Lamp OFF

● Lamp ON

## 7. PARTS

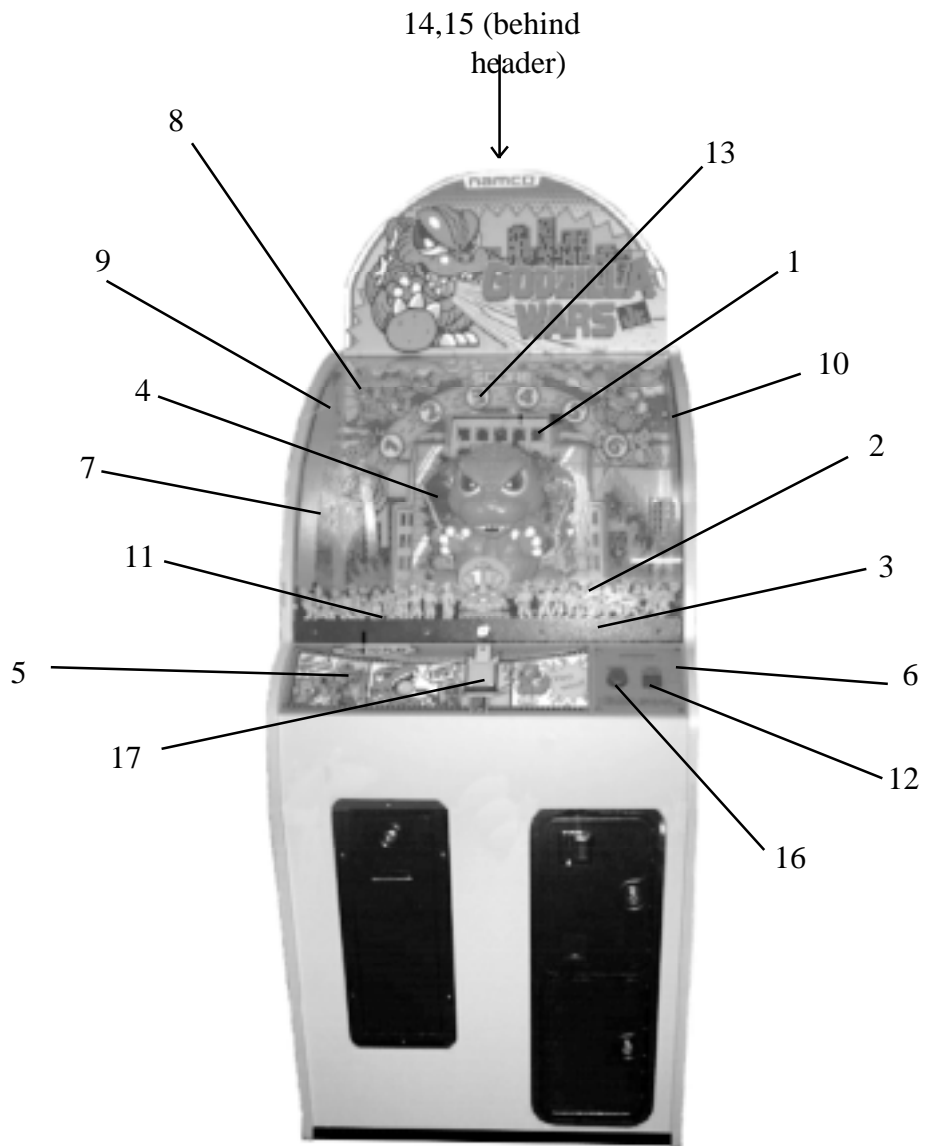



<b>Item</b>	<b>Description</b>	<b>Part No</b>
1	Building Vac-Form	88300850
2	Island Vac-Form	88300851
3	Field Guard Vac-Form	88300852
4	Rear Guard Acrylic	88300848
5	Play Panel	-----
6	Credit Display Panel	88300870
7	Side Acrylic L&R	88300846
8	Main Dome	88300845
9	Dome Stay LH	88300865
10	Dome Stay RH	88300866
11	Playfield Acrylic	88300847
12	Credit Display	81000112
13	Display Lamps 24v 3w Wedge Lamp	64000034
14	Speaker 4 1/2"	62000006
15	Speaker Grille	87800011
16	Credit Dispense Button	60200233
17	Bomb Button	60200257

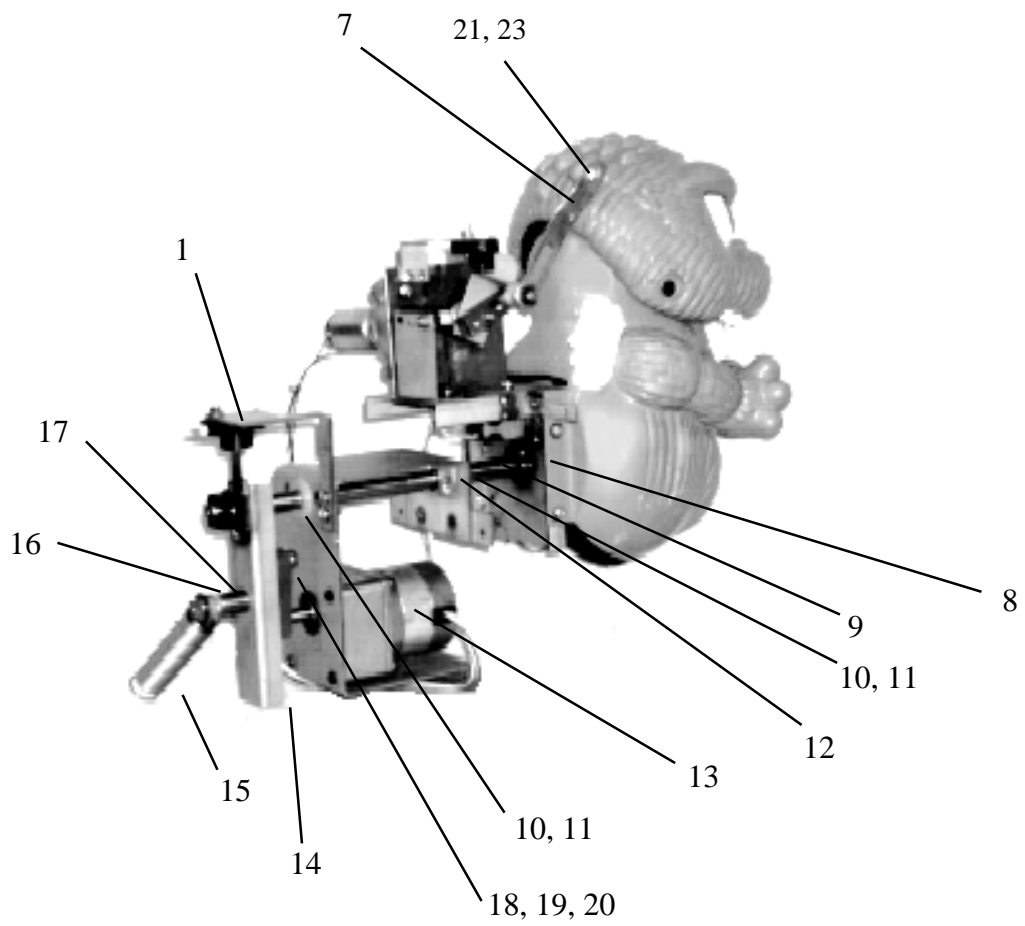
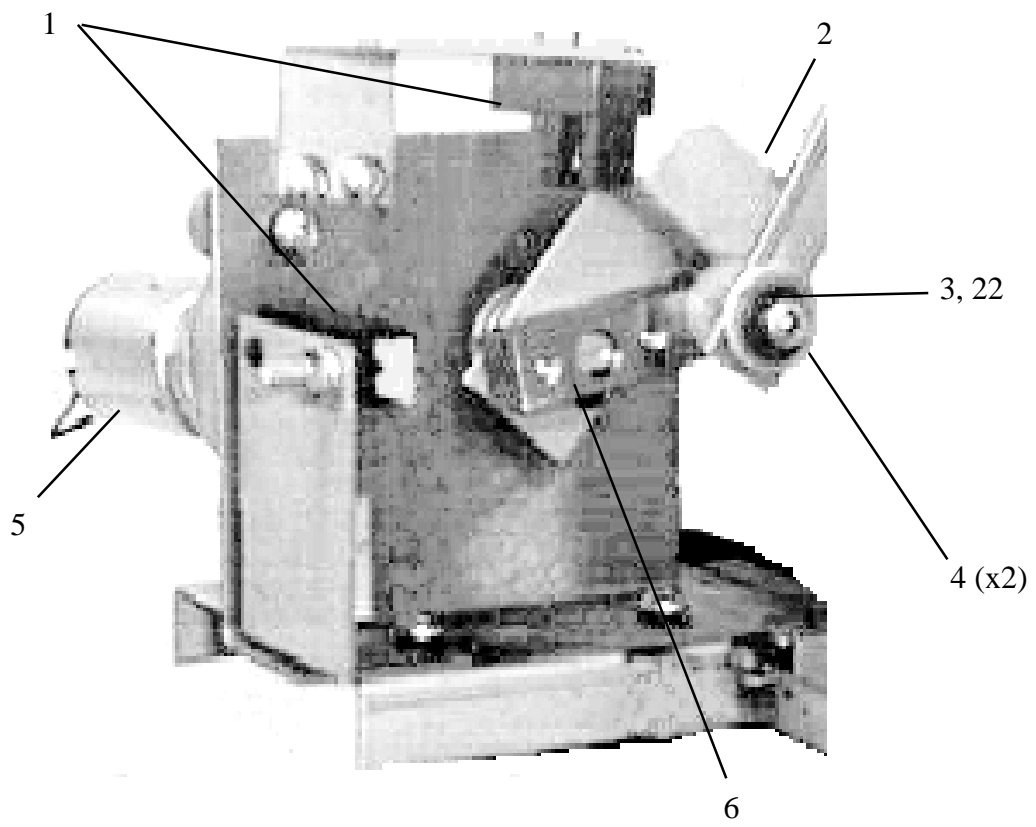

Item	Description	Part No
1	Opto Interrupter	88300893
2	Opto Interrupt Plate	88300901
3	Link Arm Stand-Off - Lower	88300896
4	Washer Link Arm Stand-Off	88300899
5	Mouth Motor 12v DC 40rpm	88300892
6	Crank Arm	88300900
7	Mouth Link Arm	88300894
8	Main Shaft & Mntg Assy	88300871
9	External Circlip 12mm	88300875
10	Delrin Bush	88300877
11	Nylon Washer	88300876
12	Retaining Clip	88300874
13	Main Motor 12v Step	88300885
14	Spring Bracket Upper	88300880
15	Step Motor Stabilising Spring	88300882
16	Spring Retainer	88300878
17	Spring Retainer Spacer	88300879
18	Roller Arm	88300885
19	Roller	88300886
20	Roller Bush	88300886
21	Link Arm Stand-Off - Upper	88300885
22	Spacing Bush - Lower	88300897
23	Spacing Bush - Upper	88300898

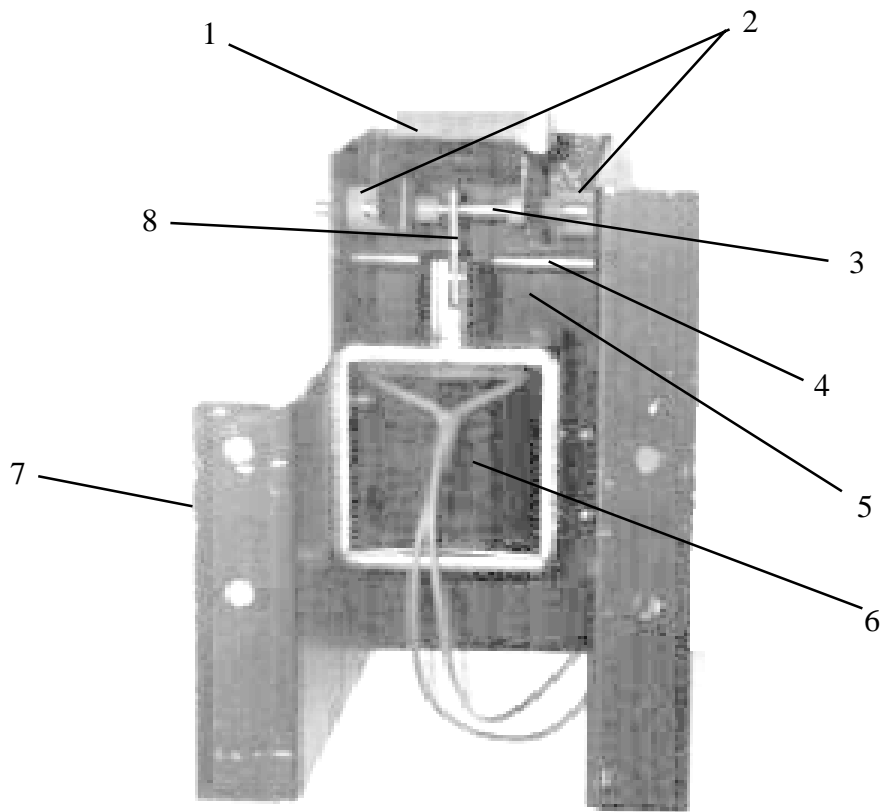

Item	Description	Part No
1	Flip Arm	88300903
2	Spacer	88300917
3	Rod - Short	88300907
4	Rod - Long	88300906
5	Spring	88300909
6	Solenoid	88300908
7	Ball Shooter Main Bracket	88300902
8	Solenoid Link Plate	88300904

# 8. SCHEMATIC - Power supply

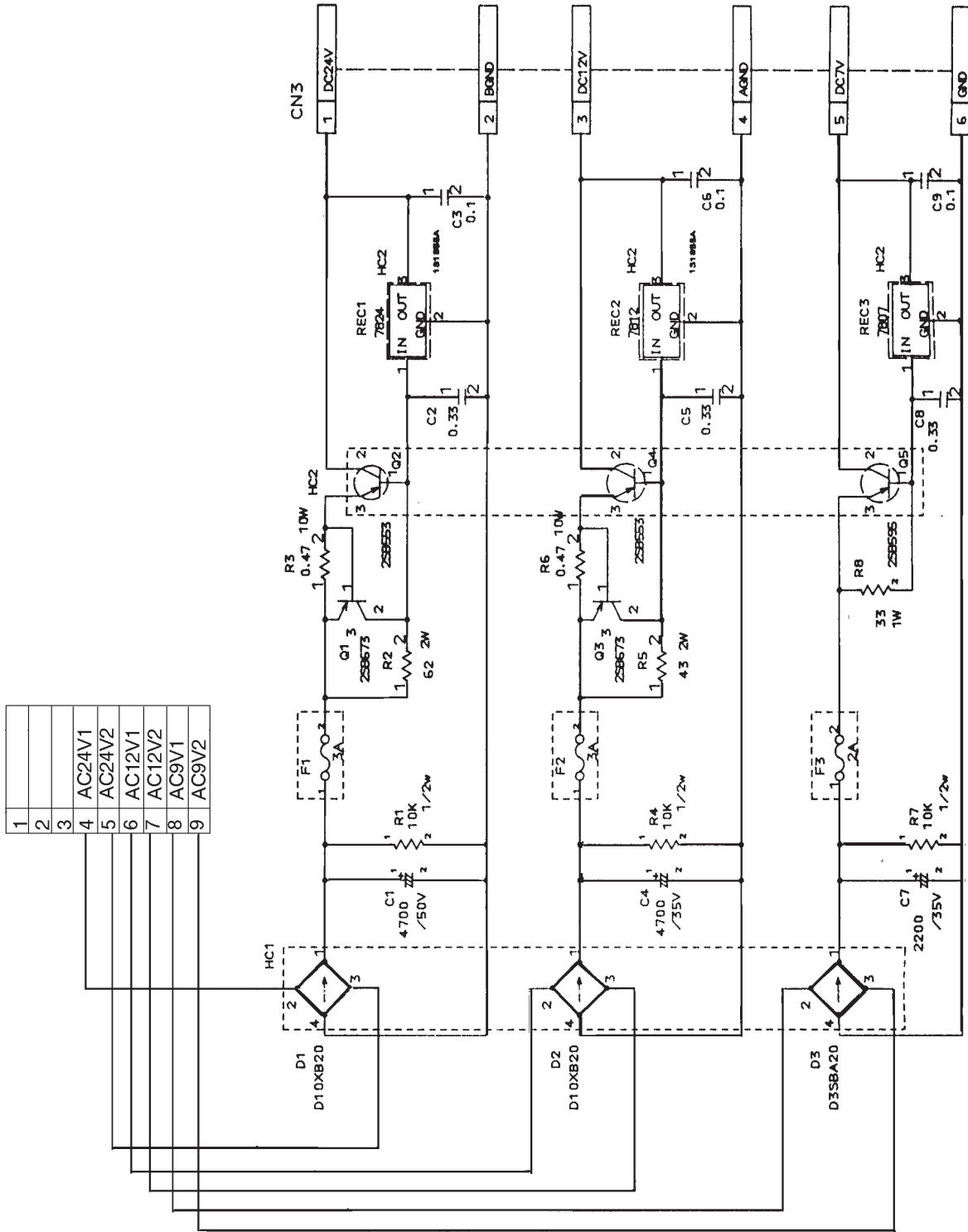

POWER SUPPLY BOARD

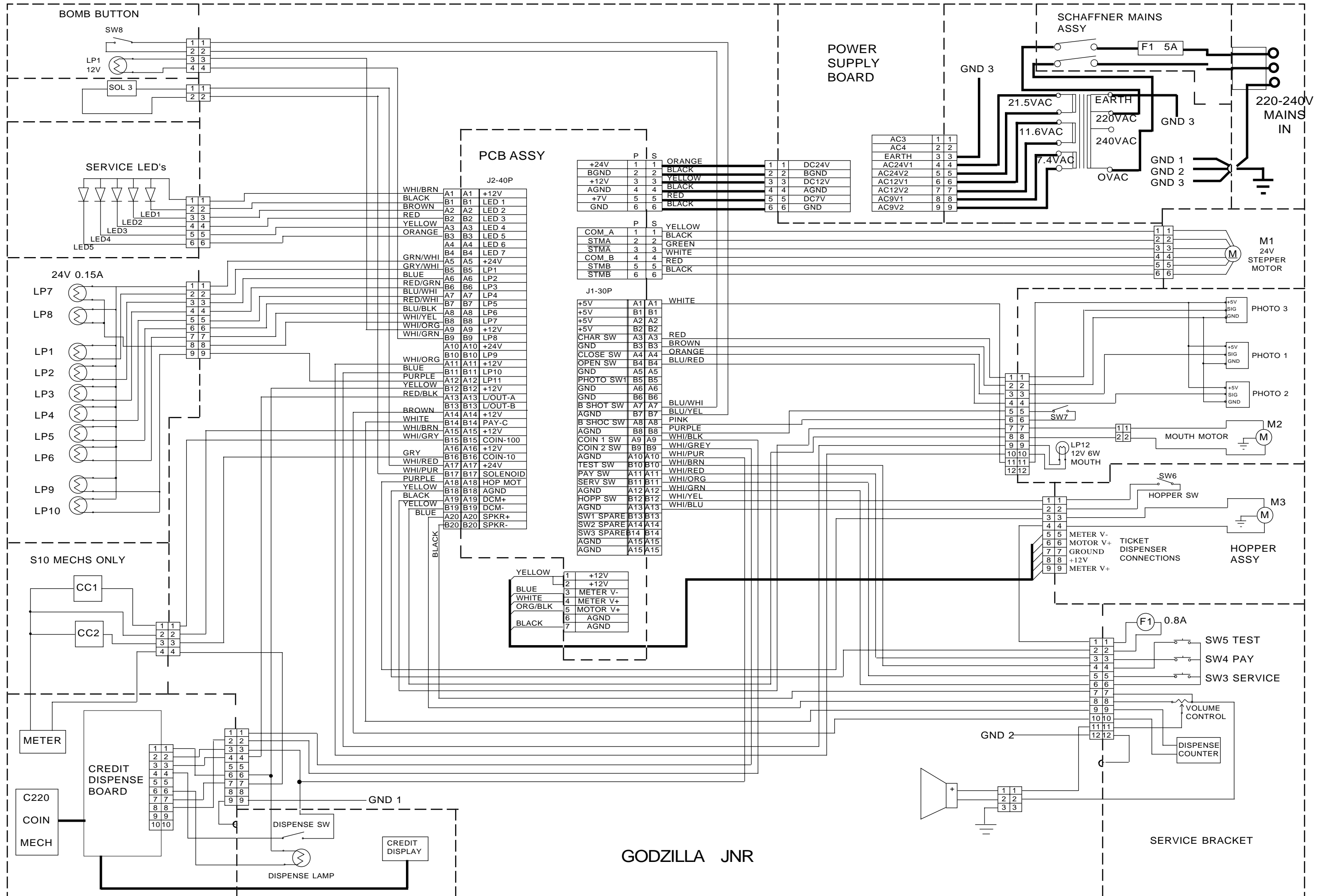

GODZILLA JNR

	P	S			
+24V	1	1	ORANGE	1	1
BGND	2	2	BLACK	2	2
+12V	3	3	YELLOW	3	3
AGND	4	4	BLACK	4	4
+7V	5	5	RED	5	5
GND	6	6	BLACK	6	6

	P	S			
COM_A	1	1	YELLOW		
STMA	2	2	BLACK		
STMA	3	3	GREEN		
COM_B	4	4	WHITE		
STMB	5	5	RED		
STMB	6	6	BLACK		

	P	S			
+5V	A1	A1	WHITE		
+5V	B1	B1			
+5V	A2	A2			
+5V	B2	B2			
CHAR SW	A3	A3	RED		
GND	B3	B3	BROWN		
CLOSE SW	A4	A4	ORANGE		
OPEN SW	B4	B4	BLU/RED		
GND	A5	A5			
PHOTO SW1	B5	B5			
GND	A6	A6			
GND	B6	B6			
B SHOT SW	A7	A7	BLU/WHI		
AGND	B7	B7	BLU/YEL		
B SHOC SW	A8	A8	PINK		
AGND	B8	B8	PURPLE		
COIN 1 SW	A9	A9	WHI/BLK		
COIN 2 SW	B9	B9	WHI/GREY		
AGND	A10	A10	WHI/PUR		
TEST SW	B10	B10	WHI/BRN		
PAY SW	A11	A11	WHI/RED		
SERV SW	B11	B11	WHI/ORG		
AGND	A12	A12	WHI/GRN		
HOPP SW	B12	B12	WHI/YEL		
AGND	A13	A13	WHI/BLU		
SW1 SPARE	B13	B13			
SW2 SPARE	A14	A14			
SW3 SPARE	B14	B14			
AGND	A15	A15			
AGND	A15	A15			

YELLOW	1	+12V
BLUE	2	+12V
WHITE	3	METER V-
ORG/BLK	4	METER V+
BLACK	5	MOTOR V+
BLACK	6	AGND
BLACK	7	AGND

AC3	1	1
AC4	2	2
EARTH	3	3
AC24V1	4	4
AC24V2	5	5
AC12V1	6	6
AC12V2	7	7
AC9V1	8	8
AC9V2	9	9