



Konami®

警告

WARNING

「グリーンベレー」は、弊社(コナミ)が、独自に開発したオリジナル製品であり、著作権、工業所有権、その他の諸権利は、コナミ株式会社が所有しております。

「GREEN BERET」 is an original game developed by Konami Industry Co.,Ltd.

Konami Industry Co.,Ltd. reserves all the copyrights, trademarks and other industrial property rights with respect to this game.

技術的な説明

- (1) P.Cボードの電源仕様
GND-Vcc5V 5A以上
GND-(+12V) 東線図参照
- (2) モニターへの接続は、国内で販売されている、一般的なカラーモニターに接続可能です。
- (3) 音量の調節は、P.Cボード上のボリュームで行い、右へ回すと大きくなります。
- (4) P.Cボードは精密装置のため、運送時などは、取扱い方に注意して下さい。

遊び方

- 8方向ジョイスティックと『ナイフ』『ショット(武装時のみ)』の2つのボタンでプレイヤーを操作してください。
- ジョイスティックを上に入れれば『ジャンプ』、下に入れれば『伏せ』となります。ハシゴの前では上に入れれば『登る』、下に入れると『降りる』となります。
- 近づいて来る敵はナイフでやっつけます。また、黒い服装の敵をやっつけると武器が飛び出し、それを取るとショットボタンで武器を撃つ事が出来ます。武器にはロケット砲、手榴弾、火炎放射器の三種類があります。
- 敵、敵の撃った弾、犬、地雷等に当たるとアウトとなります。
- ステージは全部で4種類あって各ステージの最後に登場するボス敵をやっつけるとパターンクリアとなります。

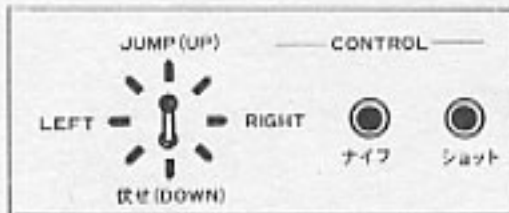

ディップスイッチNo.1セット

1. コインスイッチNo.1セット

SW	4	3	2	1	コイン	プレイ
○	OFF	OFF	OFF	OFF	1	1
			OFF	ON	1	2
			ON	OFF	1	3
			ON	ON	1	4
	OFF	ON	OFF	OFF	1	5
			OFF	ON	1	6
			ON	OFF	1	7
			ON	ON	2	1
	ON	OFF	OFF	OFF	2	3
			OFF	ON	2	5
			ON	OFF	3	1
			ON	ON	3	2
	ON	ON	OFF	OFF	3	4
			OFF	ON	4	1
			ON	OFF	4	3
			ON	ON	フリープレイ	

(注) フリープレイとはコインを投入せずプレイできる状態をいう。

Technical Information

- (1) Required Power Capacity
GND-Vcc 5V 5A or more
GND-(+12V) See the WIRING DIAGRAM
- (2) Output
R (red) analog, positive
G (green) analog, positive
B (blue) analog, positive
Sync. H-V complexed, negative
- (3) Adjusting Volume of sound.
Turn the volume right and it becomes louder.
- (4) Handle with care.

Play Instruction

Move soldier to the right of the screen and destroy the enemy soldiers by pressing 'Knife Button.' By destroying the enemy commanding officer you are able to capture his weapon (a flame thrower, a rocket gun or hand grenades). These special weapons will destroy the enemy soldiers en masse.

Use the shoot button to activate the special weapons you have captured.

Jump or lie down to avoid the enemy bullets. Avoid the mines by climbing the ladders, buildings, etc.

During the last battle at the end of each stage, crack troops from the enemy will attack, destroy them to advance to the next level.

The game is completed when you have rescued the captives at the end of the fourth stage.



DIP SW No.1 Settings

1. Coin switch No.1 settings

SW	4	3	2	1	コイン	プレイ
○	OFF	OFF	OFF	OFF	1	1
			OFF	ON	1	2
			ON	OFF	1	3
			ON	ON	1	4
	OFF	ON	OFF	OFF	1	5
			OFF	ON	1	6
			ON	OFF	1	7
			ON	ON	2	1
	ON	OFF	OFF	OFF	2	3
			OFF	ON	2	5
			ON	OFF	3	1
			ON	ON	3	2
	ON	ON	OFF	OFF	3	4
			OFF	ON	4	1
			ON	OFF	4	3
			ON	ON	フリープレイ	

(Attention) free play: You can play games without coin.

2. コインスイッチNo. 2セット

SW	8	7	6	5	コイン	プレイ
○	OFF	OFF	OFF	OFF	1	1
			OFF	ON	1	2
			ON	OFF	1	3
			ON	ON	1	4
	OFF	ON	OFF	OFF	1	5
			OFF	ON	1	6
			ON	OFF	1	7
			ON	ON	2	1
	ON	OFF	OFF	OFF	2	3
			OFF	ON	2	5
			ON	OFF	3	1
			ON	ON	3	2
	ON	ON	OFF	OFF	3	4
			OFF	ON	4	1
			ON	OFF	4	3
			ON	ON	無効	

2. Coin switch No.2 settings

SW	8	7	6	5	Coin	Play
○	OFF	OFF	OFF	OFF	1	1
			OFF	ON	1	2
			ON	OFF	1	3
			ON	ON	1	4
	OFF	ON	OFF	OFF	1	5
			OFF	ON	1	6
			ON	OFF	1	7
			ON	ON	2	1
	ON	OFF	OFF	OFF	2	3
			OFF	ON	2	5
			ON	OFF	3	1
			ON	ON	3	2
	ON	ON	OFF	OFF	3	4
			OFF	ON	4	1
			ON	OFF	4	3
			ON	ON	Invalidity	

ディップスイッチNo.2セット

1. プレーヤ数

SW	2	1	プレーヤ数
○	OFF	OFF	2
	OFF	ON	3
	ON	OFF	5
	ON	ON	7

DIP SW No.2 Settings

1. The Number of Player's Life

SW	2	1	Number
○	OFF	OFF	2
	OFF	ON	3
	ON	OFF	5
	ON	ON	7

2. テーブル型・アップライト型切り換え

SW	3	タイプ
○	OFF	テーブル型
	ON	アップライト型

2. Change of Table or Upright

SW	3	TYPE
○	OFF	TABLE
	ON	UPRIGHT

3. ボーナス設定

	5	4	1回目	2回目	以降
○	OFF	OFF	30,000	70,000	70,000毎
	OFF	ON	40,000	80,000	80,000毎
	ON	OFF	50,000	100,000	100,000毎
	ON	ON	50,000	200,000	200,000毎

3. Bonus Life

	5	4	FIRST	SECOND	3RD AND ON
○	OFF	OFF	30,000	70,000	EVERY 70,000
	OFF	ON	40,000	80,000	EVERY 80,000
	ON	OFF	50,000	100,000	EVERY 100,000
	ON	ON	50,000	200,000	EVERY 200,000

4. ゲームの難度

SW	7	6	難度
○	OFF	OFF	易しい
	OFF	ON	普通
	ON	OFF	難しい
	ON	ON	大変難しい

4. Difficulty of the game

SW	7	6	Difficulty
○	OFF	OFF	Easy
	OFF	ON	Normal
	ON	OFF	Difficult
	ON	ON	Very Difficult

5. デモ中の音

SW	8	音
○	OFF	無
	ON	有

5. Sound in attractive mode

SW	8	Sound
○	OFF	OFF
	ON	ON

ディップスイッチNo.3セット

1. ビデオスクリーン反転切り換え(モニター)

SW	1	
○	OFF	正常
	ON	反転

2. VSアップライトタイプ切り換え

SW	2	タイプ
○	OFF	通常タイプ
	ON	VSアップライトタイプ

*SW3, SW4は未使用

○は標準設定

DIP SWITCH No.3 Settings

1. Video Screen Flip

SW	1	
○	OFF	Normal
	ON	Upside Down

2. Single/Dual Control Upright

SW	2	Type
○	OFF	Single Upright Control
	ON	Dual Upright Control

*SW3, SW4, Not Used

○shows recommended setting.

セルフ・テスト

正常な場合: 'OK'と表示後、ゲームが始まる。

異常な場合: 'BAD'と表示され、止まる。

Self Test

Normal: 'OK' will be displayed. Then game program will be started.

Abnormal: 'BAD' will be displayed. Then stopped.

束線図

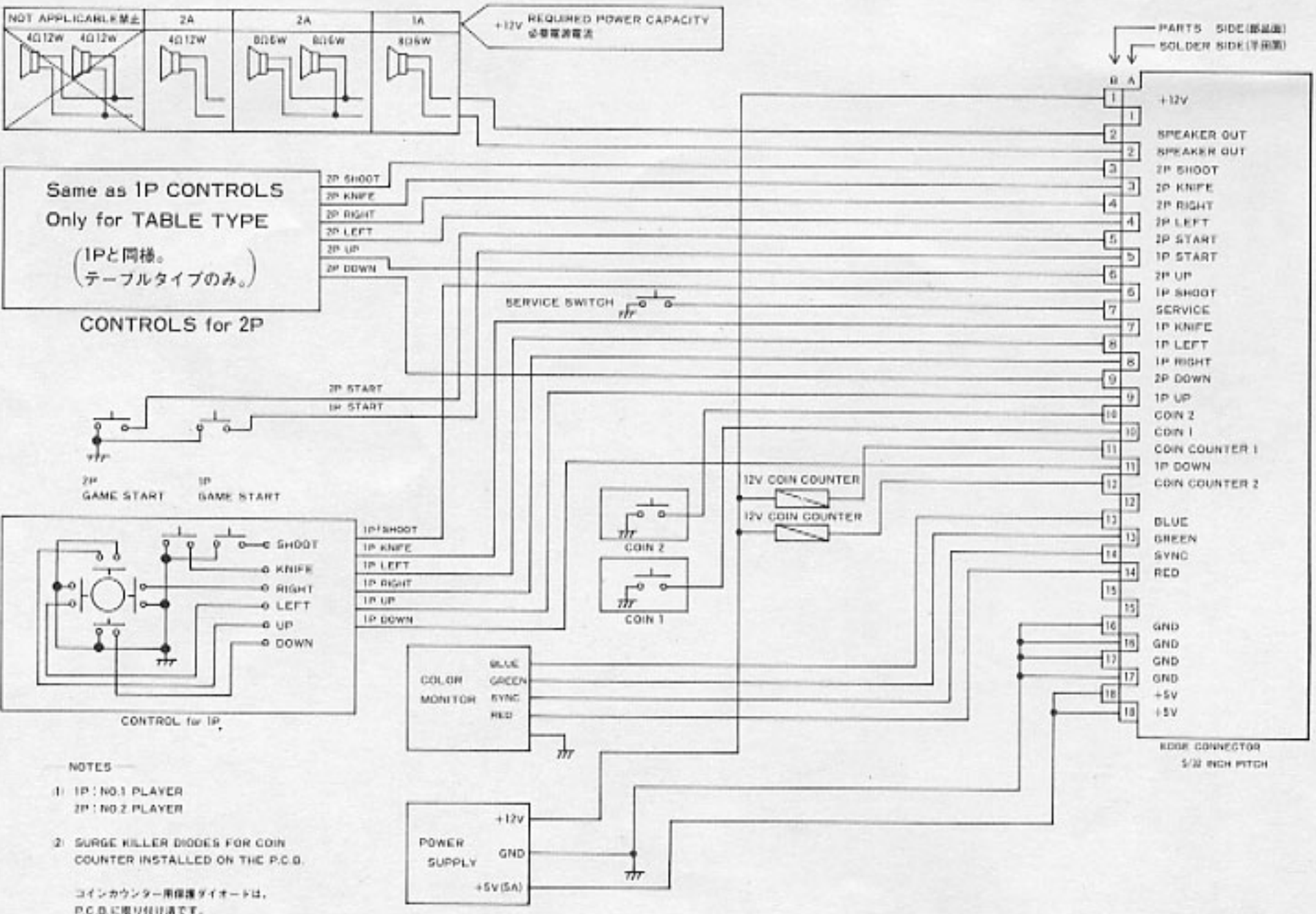

WIRING DIAGRAM