



STRIKER PRO OWNERS AND SERVICE MANUAL

INNOVATIVE CONCEPTS IN ENTERTAINMENT INC.

10123 MAIN STREET, CLARENCE, NY 14031

SERVICE: 1-716-759-0360

FAX: 1-716-759-0884

E-MAIL: service@icegame.com

WEBSITE: www.icegame.com

TABLE OF CONTENTS

SAFETY & WARNINGS.....	PAGE 3
• BEFORE YOU BEGIN	
• INSTALLATION	
• WARNING	
GAME SETUP & FEATURES.....	PAGE 4 - 6
• PLAYER CONTROLS	
• PLAYING THE GAME	
• INITIAL GAME SETUP	
DIAGNOSTIC, ADJUSTMENT & AUDIT MENU SYSTEM.....	PAGE 7 - 14
TROUBLESHOOTING.....	PAGE 15 - 16
MAINTENANCE.....	PAGE 17 - 23
PARTS LISTING.....	PAGE 24
SCHEMATICS.....	PAGE 25
WARRANTY INFORMATION.....	PAGE 27 - 28

SAFETY AND WARNINGS

BEFORE YOU BEGIN

WARNING: WHEN INSTALLING THIS GAME, A GROUNDED A.C. RECEPTACLE MUST BE USED. FAILURE TO DO SO COULD RESULT IN INJURY TO YOURSELF OR OTHERS. FAILURE TO USE A GROUNDED RECEPTACLE COULD ALSO CAUSE IMPROPER GAME OPERATION, OR DAMAGE TO THE ELECTRONICS.

DO NOT DEFEAT OR REMOVE THE GROUNDING PRONG ON THE POWER CORD FOR THE SAME REASON AS GIVEN ABOVE. USING AN IMPROPERLY GROUNDED GAME COULD VOID YOUR WARRANTY.

HAVE A QUALIFIED ELECTRICIAN CHECK YOUR A.C. RECEPTACLE TO BE SURE THE GROUND IS FUNCTIONING PROPERLY.

INSTALLATION

The game comes ready to play with just a few simple things to keep in mind.

1. Plug the game into the A.C. outlet and turn on power to the game. The switch for the game is located on a power module on the outside rear of the game.

THIS GAME IS DESIGNED TO DISSIPATE STATIC ELECTRICITY THROUGH THE GROUNDING PLANE OF THE GAME. IF THE A.C. GROUND DOES NOT WORK, THE GAME COULD DISCHARGE STATIC ELECTRICITY THROUGH THE GAME CIRCUITRY, WHICH COULD CAUSE DAMAGE.

2. Make sure the game is level after installation. It is necessary to make sure the game is level for safety concerns.
3. Check that the A.C. voltage rating on the back of the game matches the A.C. voltage of your location.

THE POWER SUPPLY IS NOT VOLTAGE ADJUSTABLE. TO OPERATE THE GAME AT VOLTAGES OTHER THAN THOSE IT WAS DESIGNED FOR. PLEASE CONTACT OUR SERVICE DEPARTMENT FOR VOLTAGE CONVERSION INFORMATION.

WARNING

DO NOT remove any of the components on the main board (e.g. compact flash and eproms) while the game is powered on. This may cause permanent damage to the parts and the main board. Removing any main board component part while powered on will void the warranty.

NOTE: THIS GAME IS INTENDED FOR INDOOR USE ONLY.
ON THE BACK PANEL OF THE GAME: WARNING: SHOCK HAZARD - DO NOT OPEN. REFER SERVICING TO SERVICE PERSONNEL.

GAME SETUP AND FEATURES

Before putting the game in service, it may be necessary to adjust the DC voltage output from the power supply. First remove the rear doors.

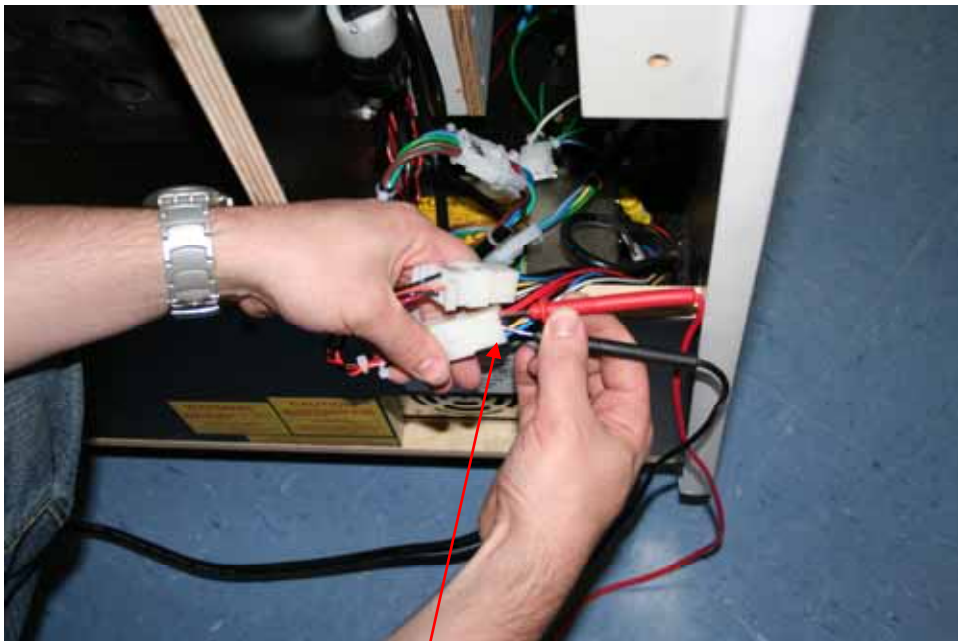

With the power on the game check the output voltage from the connector from the power supply. The specification is 4.95—5.05 volts DC. Use the RED and BLACK wires to check voltage.

GAME SETUP AND FEATURES

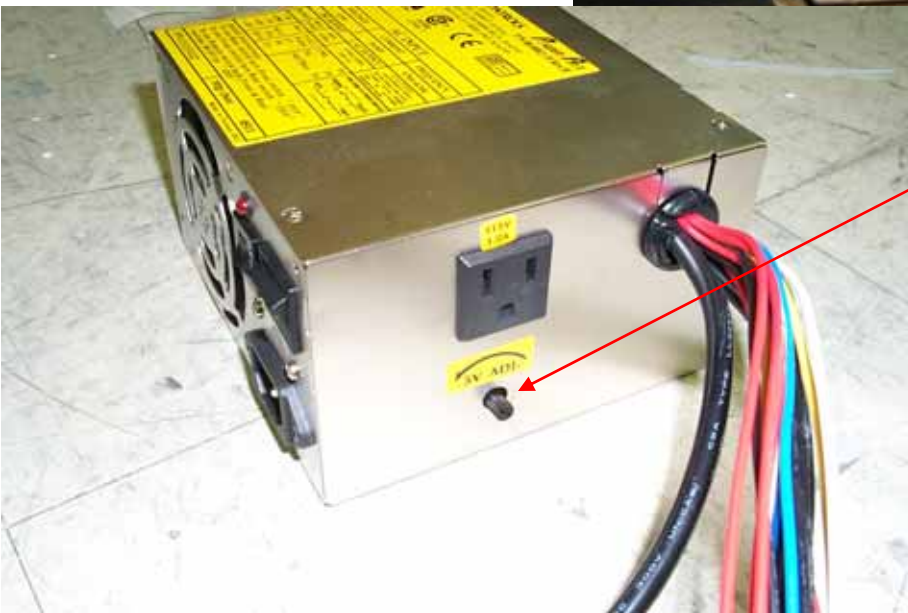

If the voltage is out of the specified range, adjust it on the power supply by turning the screw as shown.

GAME SETUP AND FEATURES

Game Setup Location

The sizes shown on the diagram below will help you determine the area required for your game, and where you might want the game to be placed.

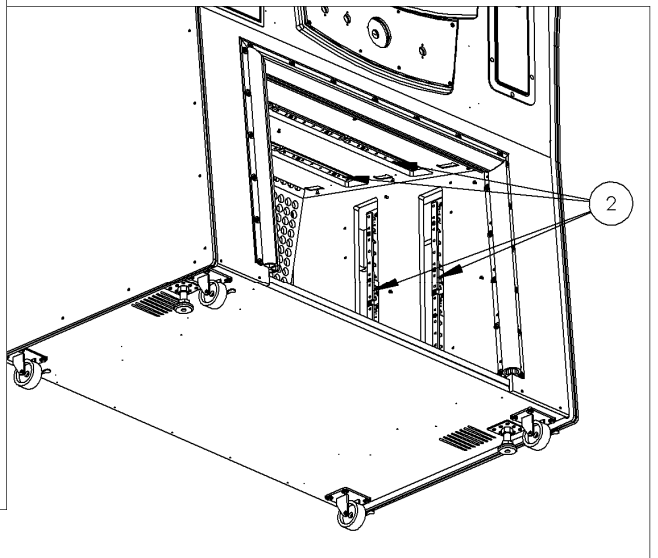
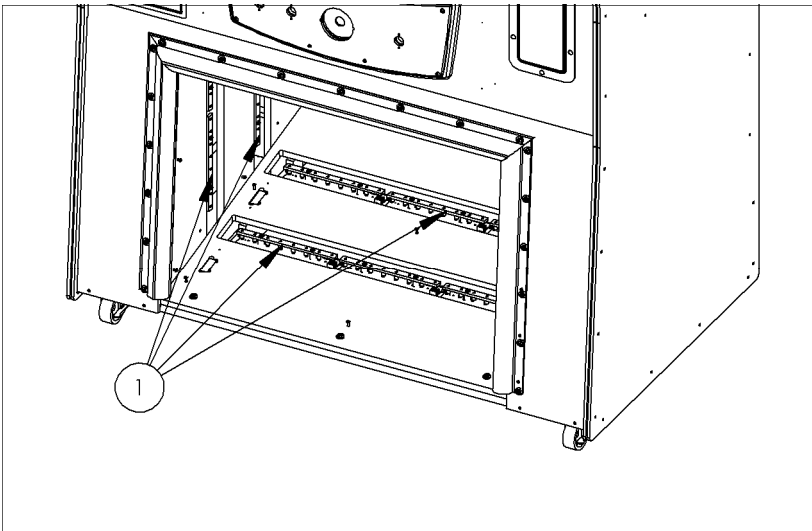
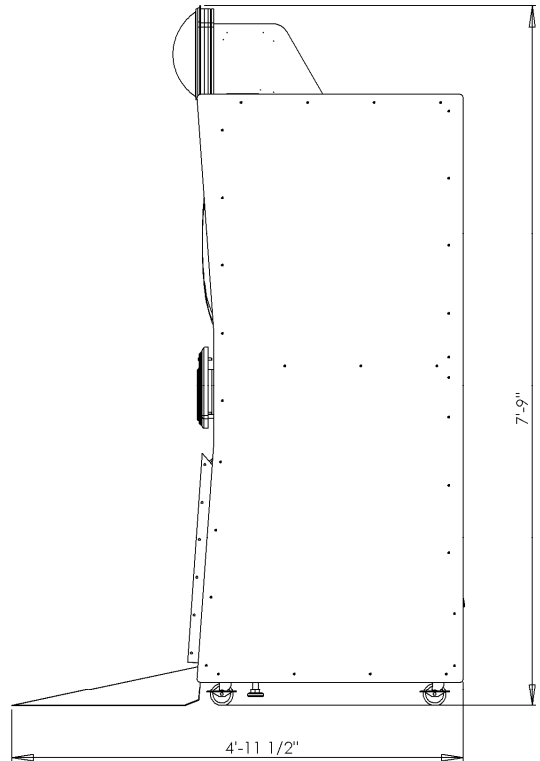
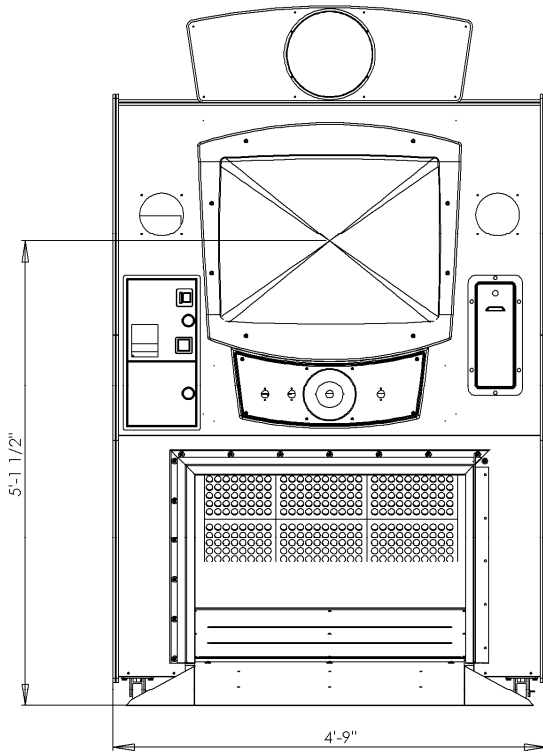

ITEM NO.	PART NO.	DESCRIPTION	QTY.
1	WC2011	RECIEVER BOARDS	10
2	WC2012	TRANSMITTER BOARDS	10

DIAGNOSTIC, ADJUSTMENT AND AUDIT MENU SYSTEM

Administrator Menu

To access the Administrator Menu, select the right (red) button.



1

2

3

Administrator Menu

To move through the menu, use "L" (1) on the Control Panel to go up, "R" (2) on the Control Panel to go down, and "SELECT" (3) to select menu options.

Administrator Menu

CURRENCY SETTINGS
CLEAR HIGH SCORES
COUNTRY SETTINGS
GAMEPLAY SETTINGS
REWARD SETTINGS
ATTRACT MODE SETTINGS
MENU TIMING SETTINGS
SENSOR DIAGNOSTICS
RESET TO DEFAULTS
BACK TO GAME

TOTAL COINS IN INPUT #1: 0
TOTAL COINS IN INPUT #2: 0
TOTAL TICKETS DISPENSED: 0

DIAGNOSTIC, ADJUSTMENT AND AUDIT MENU SYSTEM

Currency Menu	
FREE PLAY:	NO
COIN INPUT #1 VALUE:	1
COIN INPUT #2 VALUE:	1
COST OF 1P GAME:	2
COST OF 2P GAME:	4
BACK ONE LEVEL	
BACK TO GAME	

Free Play - If set to 'Yes' the game is set on free play and no coins or credits will be required to play.

Coin Input #1 Value - Set value of each coin inputted. (default=1, Min=1, Max=20)

Coin Input #2 Value - Set value of each coin inputted. (default=1, Min=1, Max=20)

Cost of 1P Game - Set cost per 1 player game. (default=1, Min=1, Max=100)

Cost of 2P Game—Set cost per 2 player game. (default=2, Min=1, Max=100)

Back One Level— Return one screen in the administrator menu.

Back To Game—Return to the game.

Clear High Scores	
RESET BEGINNER SCORES	
RESET ADVANCED SCORES	
RESET PROFESSIONAL SCORES	
RESET SOFT COUNTERS	
BACK ONE LEVEL	
BACK TO GAME	

Reset Beginner Scores—Clear beginner high score. (default=no, Min=no, Max=yes)

Reset Advanced Scores—Clear advanced high score. (default=no, Min=no, Max=yes)

Reset Professional Scores—Clear professional high score. (default=no, Min=no, Max=yes)

Reset Soft Counters—Clear soft counter. (default=no, Min=no, Max=yes)

Back One Level— Return one screen in the administrator menu.

Back To Game—Return to the game.

DIAGNOSTIC, ADJUSTMENT AND AUDIT MENU SYSTEM

Country Settings

Select COUNTRY SETTINGS at the ADMINISTRATOR MENU to select your default country.

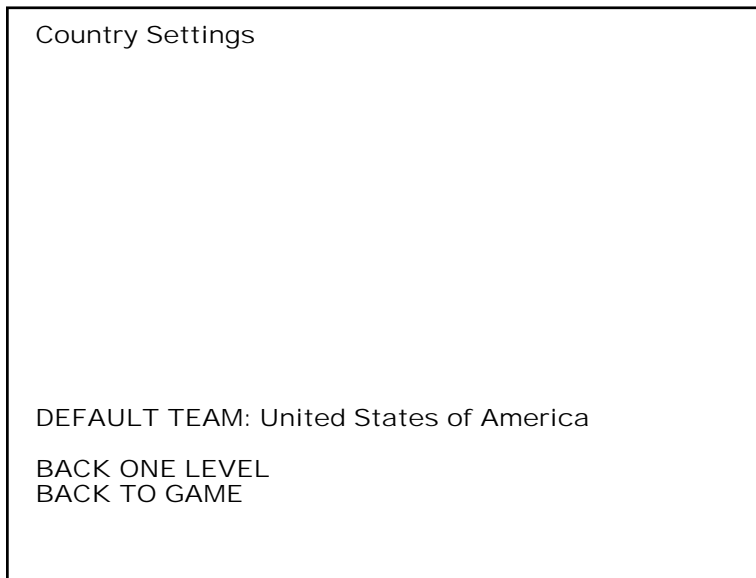

There are 100 default country flags to choose from.

Press “L” on the Control Panel three times to move the cursor to “Default Team”.

Press “**Select / Start**” to highlight.

User “L” & “R” buttons on the Control Panel to traverse the flags. Once you highlight your selection, press “**Select / Start**” to select.

Use “L” & “R” buttons on the Control Panel to move up & down the menu. Choose “**BACK ONE LEVEL**” to back up through the menu.

Game Play Settings

Select GAME PLAY SETTINGS at the ADMINISTRATOR MENU to adjust the game play.

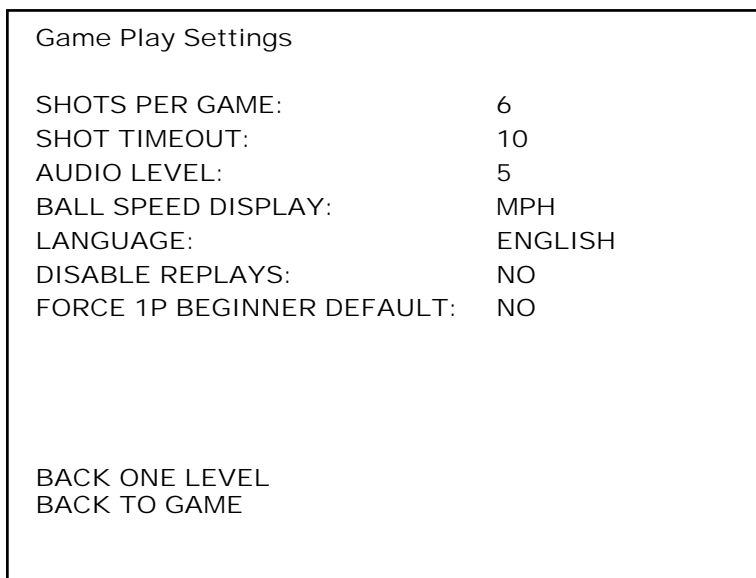

Shot per Game: Set number of shots per game. (default=6, Min=4, Max=6)

Shot Timeout: Set timer for each kick. (default=20, Min=15, Max=60)

Audio Level: Set Volume. (default=5, Min=0, Max=10) 0=off.

Ball Speed Display: Set speed reading. (default=KPH, Min=KPH, Max=MPH)

Language: Choose between the following:

- English (default)
- Spanish
- French
- Dutch
- Italian

Disable Replays: If set to “yes”, Instant replays will be disabled.

Force 1P Beginner Default: xxx

DIAGNOSTIC, ADJUSTMENT AND AUDIT MENU SYSTEM

Reward Settings

Select REWARD SETTINGS at the ADMINISTRATOR MENU to determine ticket payout.

Reward Settings

MINIMUM TICKETS: 1
MAXIMUM TICKETS: 3

BEGINNER
ADVANCED
PROFESSIONAL

BACK ONE LEVEL
BACK TO GAME

Minimum Tickets - Set minimum ticket payout per game. (default=1, Min=0, Max=50) 0=off

Maximum Tickets - Set maximum ticket payout per game. (default=3, Min=0, Max=10) 0=off

Reward Settings

Select REWARD SETTINGS (Beginner) at the ADMINISTRATOR MENU to determine ticket payout.

Reward Settings—Beginner

DIRECT KICK LEFT SCORE: 300
DIRECT KICK RIGHT SCORE: 300
FREE KICK SCORE: 400
INSIDE PENALTY KICK LEFT SCORE: 500
INSIDE PENALTY KICK RIGHT SCORE: 500
PENALTY KICK SCORE: 200
BOOST BONUS POINTS: 20
MAXIMUM BOOSTS: 2
MAXIMUM BONUS KICKS: 3
POINTS PER PAYOUT: 1000
TICKETS PER PAYOUT: 1

BACK ONE LEVEL
BACK TO GAME

Direct Kick Left Score – Set points for goal scored. (default=300, Min=100, Max=5000)

Direct Kick Right Score – Set points for goal scored. (default=300, Min=100, Max=5000)

Free Kick Score – Set points for goal scored. (default=400, Min=100, Max=5000)

Inside Penalty Kick Left Score – Set points for goal scored. (default=500, Min=100, Max=5000)

Inside Penalty Kick Right Score – Set points for goal scored. (default=500, Min=100, Max=5000)

Penalty Kick Score – Set points for goal scored. (default=150, Min=100, Max=3000)

Boost Bonus Points – Set bonus points for boost kick. (default=20, Min=0, Max=100)

Maximum Boosts—Set number of boosts allowed. (default=2, Min=0, Max=10)

Maximum Bonus Kicks – Set maximum number of bonus kicks. (default=3, Min=0, Max=99)

Points Per Payout – Set amount of points for payout. (default=1000, Min=100, Max=5000)

Tickets Per Payout – Set number of kicks per payout. (default=1, Min=0, Max=10)

DIAGNOSTIC, ADJUSTMENT AND AUDIT MENU SYSTEM

Reward Settings

Select REWARD SETTINGS (Advanced) at the ADMINISTRATOR MENU to determine ticket payout.

Reward Settings—Advanced

DIRECT KICK LEFT SCORE: 400
DIRECT KICK RIGHT SCORE: 400
FREE KICK SCORE: 600
INSIDE PENALTY KICK LEFT SCORE: 700
INSIDE PENALTY KICK RIGHT SCORE: 700
PENALTY KICK SCORE: 300
BOOST BONUS POINTS: 30
MAXIMUM BOOSTS: 3
MAXIMUM BONUS KICKS: 5
POINTS PER PAYOUT: 1000
TICKETS PER PAYOUT: 1

BACK ONE LEVEL
BACK TO GAME

Direct Kick Left Score – Set points for goal scored. (default=400, Min=100, Max=5000)

Direct Kick Right Score – Set points for goal scored. (default=400, Min=100, Max=5000)

Free Kick Score – Set points for goal scored. (default=600, Min=100, Max=5000)

Inside Penalty Kick Left Score – Set points for goal scored. (default=700, Min=100, Max=5000)

Inside Penalty Kick Right Score – Set points for goal scored. (default=700, Min=100, Max=5000)

Penalty Kick Score – Set points for goal scored. (default=300, Min=100, Max=3000)

Boost Bonus Points – Set bonus points for boost kick. (default=20, Min=0, Max=100)

Maximum Boosts—Set number of boosts allowed. (default=2, Min=0, Max=10)

Maximum Bonus Kicks – Set maximum number of bonus kicks. (default=5, Min=0, Max=99)

Points Per Payout – Set amount of points for payout. (default=1000, Min=100, Max=5000)

Tickets Per Payout – Set number of kicks per payout. (default=1, Min=0, Max=10)

DIAGNOSTIC, ADJUSTMENT AND AUDIT MENU SYSTEM

Reward Settings

Select REWARD SETTINGS (Professional) at the ADMINISTRATOR MENU to determine ticket payout.

Reward Settings—Professional

DIRECT KICK LEFT SCORE: 500
DIRECT KICK RIGHT SCORE: 500
FREE KICK SCORE: 700
INSIDE PENALTY KICK LEFT SCORE: 850
INSIDE PENALTY KICK RIGHT SCORE: 850
PENALTY KICK SCORE: 600
BOOST BONUS POINTS: 50
MAXIMUM BOOSTS: 4
MAXIMUM BONUS KICKS: 5
POINTS PER PAYOUT: 100
TICKETS PER PAYOUT: 1

BACK ONE LEVEL
BACK TO GAME

Direct Kick Left Score – Set points for goal scored. (default=500, Min=100, Max=5000)

Direct Kick Right Score – Set points for goal scored. (default=500, Min=100, Max=5000)

Free Kick Score – Set points for goal scored. (default=700, Min=100, Max=5000)

Inside Penalty Kick Left Score – Set points for goal scored. (default=850, Min=100, Max=5000)

Inside Penalty Kick Right Score – Set points for goal scored. (default=850, Min=100, Max=5000)

Penalty Kick Score – Set points for goal scored. (default=600, Min=100, Max=3000)

Boost Bonus Points – Set bonus points for boost kick. (default=50, Min=0, Max=100)

Maximum Boosts—Set number of boosts allowed. (default=4, Min=0, Max=10)

Maximum Bonus Kicks – Set maximum number of bonus kicks. (default=5, Min=0, Max=99)

Points Per Payout – Set amount of points for payout. (default=1000, Min=100, Max=5000)

Tickets Per Payout – Set number of kicks per payout. (default=1, Min=0, Max=10)

DIAGNOSTIC, ADJUSTMENT AND AUDIT MENU SYSTEM

Attract Mode Settings

Select ATTRACT MODE SETTINGS at the ADMINISTRATOR MENU.

Attract Mode Settings

ATTRACT DEAD TIME: 20
ATTRACT AUDIO LEVEL: 3
HIGH SCORE HOLD TIME: 5

Back One Level
Back To Game

Attract Dead Time – Set time after attract loop that you can't re-trigger attract loop (default=20, Min=0, Max=360)

Attract Audio Level – Set attract audio level. (default=3, Min=0, Max=10)

High Score Hold Time – Set how long highscore table is displayed. (default=5, Min=1, Max=30)

Menu Timing Settings

Select MENU TIMING SETTINGS at the ADMINISTRATOR MENU.

Menu Timing Settings

MAX TIME ENTERING INITIALS:30
MAX TIME IN GAME SUMMARY: 10
MAX TIME IN PLAYER SELECT: 10
MAX TIME IN TEAM SELECT: 30
MAX TIME IN SKILL SELECT: 20
MINUTES BEFORE EATING CREDITS: 5

Back One Level
Back To Game

Max Time Entering Initials – Set maximum time to enter initials before timing out. (default=30, Min=10, Max=100)

Max Time in Game Summary – Set maximum time to display game summary after game is played. (default=10, Min=2, Max=30)

Max Time in Player Select - Set maximum time to select number of players. (default=10, Min=10, Max=30)

Max Time in Team Select - Set maximum time to select team before timeout. (default=20, Min=10, Max=100)

Max Time in Skill Select - Set maximum time to select skill before time out. (default=20, Min=10, Max=30)

Minutes Before Eating Credits - Set maximum time before credit is eaten. (default=5, Min=3, Max=10)

DIAGNOSTIC, ADJUSTMENT AND AUDIT MENU SYSTEM

Sensor Diagnostics

Select SENSOR DIAGNOSTICS at the ADMINISTRATOR MENU. Select these options to reset game audits.

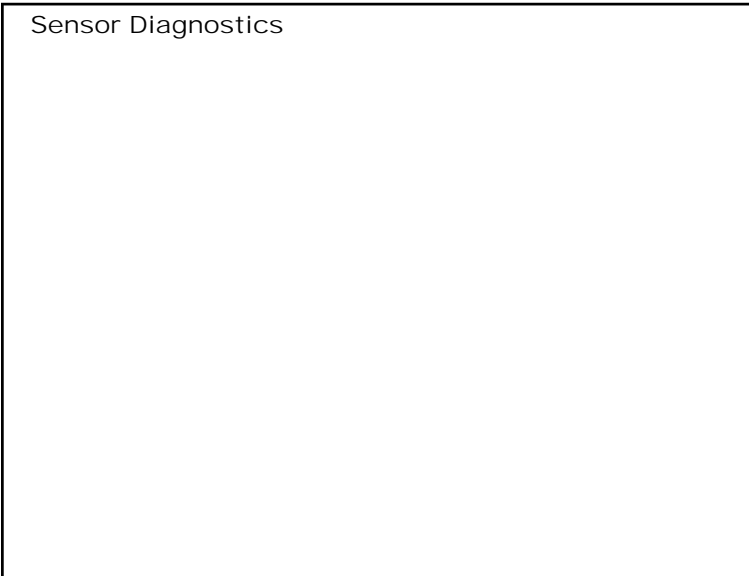

Sensor Diagnostics – Test if sensors are working. Any sensors obscured will be displayed with an X.

I.C.E. Parts/Service Dept.

Phone #: (716) - 759 – 0360

Fax #: (716) – 759 – 0884

NORMAL BUSINESS HOURS ARE:

MONDAY - FRIDAY, 9:00 AM TO 6:00 PM EST

TROUBLESHOOTING

Troubleshooting

CAUTION

This game uses complex electronic components that are very sensitive to static electricity. Observe precautions below before handling these electronics. Failure to do so may void the warranty and damage electronic assemblies.

Before servicing electronics, turn off AC power to the game. Wait for capacitors to discharge.

DO NOT remove any of the components on the main board (e.g. compact flash and eproms) while the game is powered on. This may cause permanent damage to the parts and the main board.

Before touching or handling electronic assemblies, discharge static electricity on your body. To discharge this static, begin by connecting the line cord to a grounded outlet. Don't turn on the game. Next, touch the safety ground stud of the power supply chassis.

Store electronic assemblies in an anti-static area. Use anti-static bags to store or transport the game circuit boards.

Don't remove or connect electronic assemblies when cabinet power is on. Otherwise, you'll damage electronic assemblies and void the game's warranty.

After you complete maintenance or service, replace ground wires, shields, safety covers and install and tighten ground and mounting screw.

Video game monitors generate and store potentially high voltages. Avoid touching any part of the monitor until power has been off for some time. A picture tube can maintain a hazardous charge for up to several days. Only qualified technicians should service monitors.

Game Is Non-Functional

1.	Verify that the game power switch is turned on.
2.	Verify that earth ground is properly connected and all exposed metal points are properly grounded.
3.	Verify that the line cord connector is firmly and correctly seated into the power entry module of AC power chassis.
4.	Verify that correct AC line voltage is present at the outlet
5.	Verify that the DC power supply voltages are set as follows. The following voltages should be set . +5V: +12V. Make sure there isn't any other adapters. Verify voltage.
6.	If game sounds can be heard but no picture is seen on the monitor, see monitor is non functional

TROUBLESHOOTING

Monitor Is Non-Functional

1.	Verify the cabinet has AC line voltage present at the monitor and has earth ground connected.
2.	Verify that the video is properly connected from the computers VGA card to the monitor input.
3.	Verify that the monitor remote adjustment board is properly installed and connected to the monitor chassis. Verify that brightness and contrast are set above their minimum levels.
4.	Check fuse on monitor chassis. Replace fuse or chassis as necessary.

Sound Is Non-Functional

1.	Verify the cabinet wiring is correct. Ensure that the speakers are properly connected to the audio wires from the audio amp.
2.	Verify that the power at the audio amp is: +12V:
3.	Verify that the game volume has been turned up. Check windows task bar, make sure volume is not muted or slider is not at zero (0).

Game Controls Are Non-Functional

1.	Verify that the each individual signal wire for each switch is connected.
----	---

MAINTENANCE / REPAIR

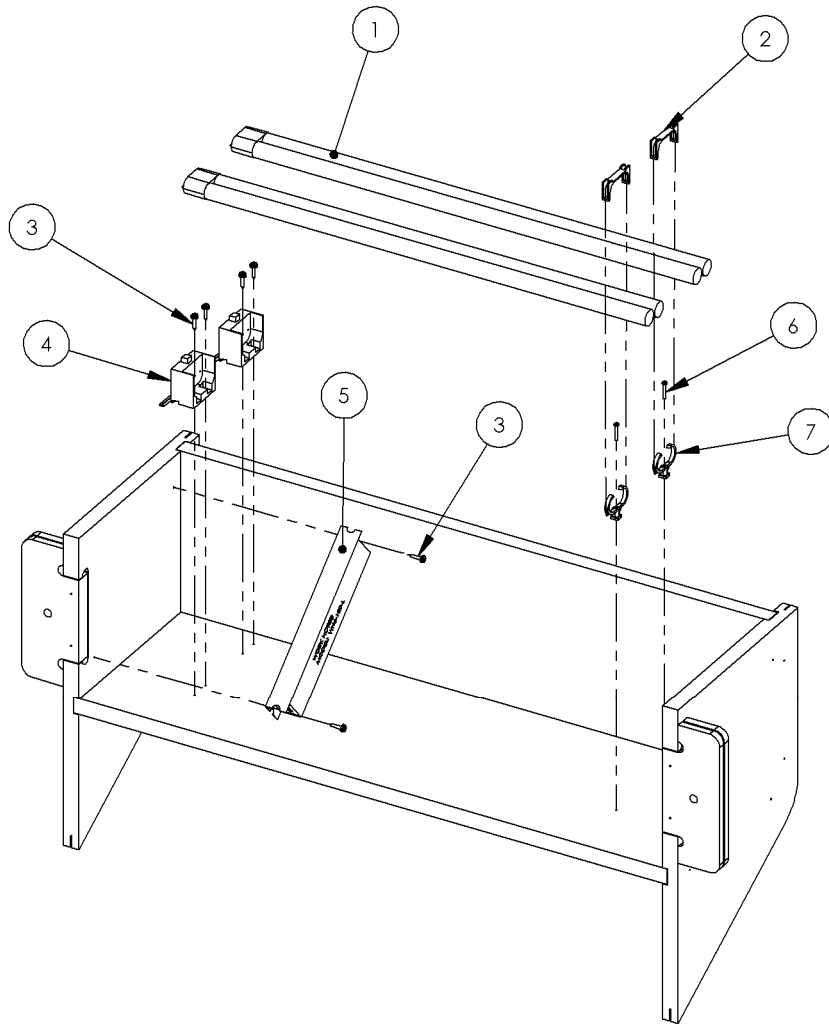

ITEM NO.	PART NO.	DESCRIPTION	QTY.
1	8312	BULB PL-L 40W	2
2	BW2017	BULB PLASTIC CLIP (1320-10)	2
3	655S	#8 x 5/8 SQ. DRIVE (SILVER)	6
4	PP250X	LIGHT SOCKET	2
5	MZ8284X	BALLAST, ASSEMBLY	1
6	6381	#4-3/4 PH PAN TY AB SCREW	2
7	BW2018	BULB PLASTIC SUPPORT (1320-13)	2

MARQUEE REMOVAL

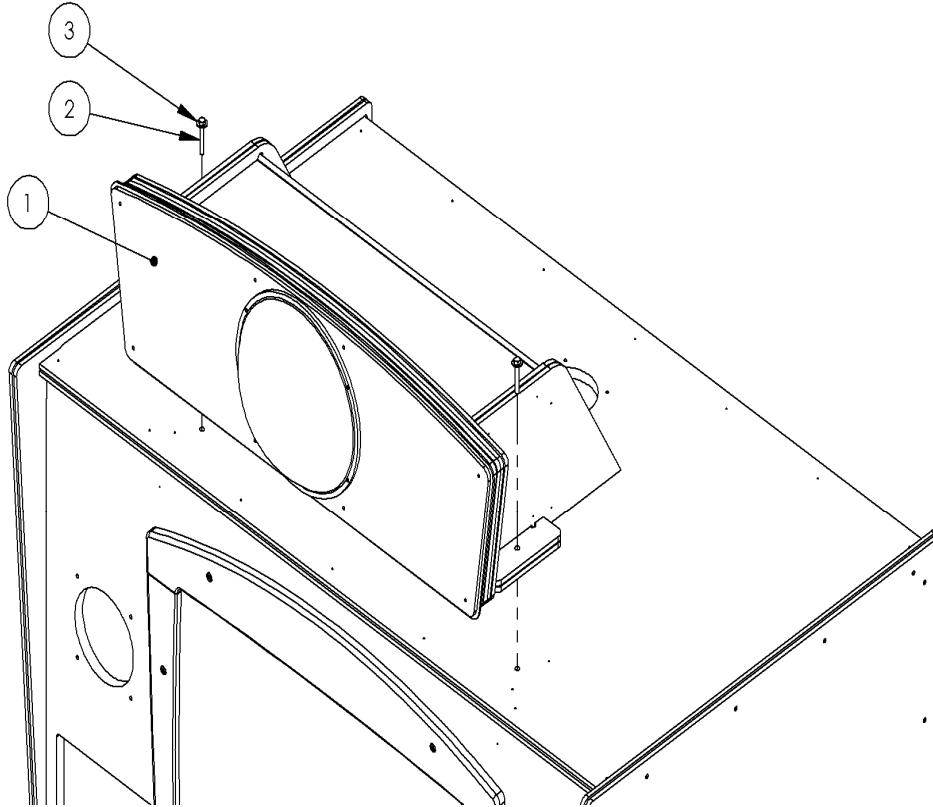

ITEM NO.	PART NO.	DESCRIPTION	QTY.
1	WC3028X	MARQUEE ASSEMBLY	1
2	6082	1/4-20 X 2.00" LG HHMB	2
3	6075	1/4 X 3/4 FLAT WASHER	2

GLASS REMOVAL / REPAIR

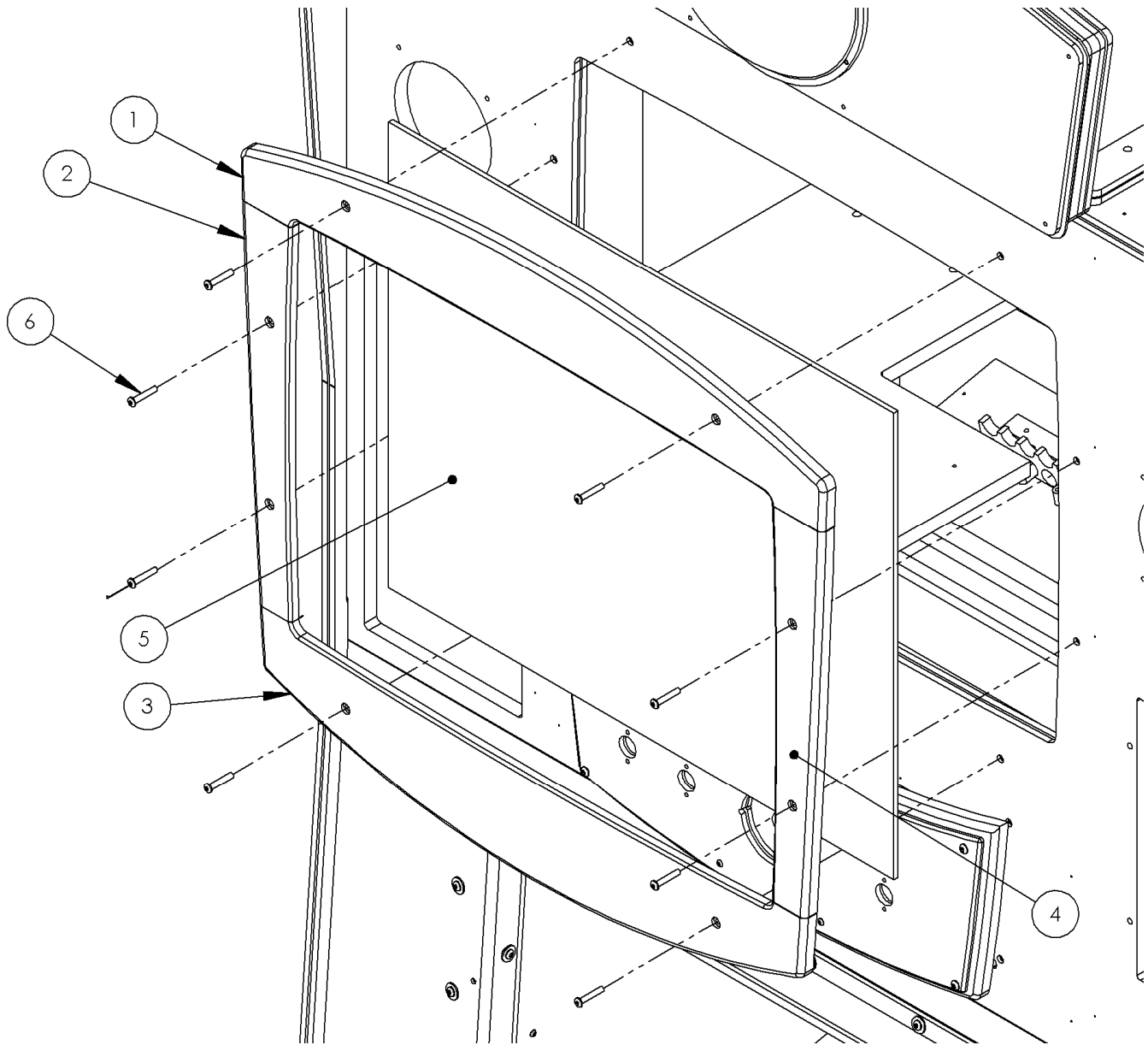

ITEM NO.	PART NO.	DESCRIPTION	QTY.
1	WC3010	TOP GLASS RETAINER	1
2	WC3006	LEFT GLASS RETAINER	1
3	WC3005	BOTTOM GLASS RETAINER	1
4	WC3007	RIGHT GLASS RETAINER	1
5	WC3027	MONITOR GLASS	1
6	6102	1/4-20 x 1 1/2 BSHCS	8

TOP/BOTTOM SENSOR REMOVAL

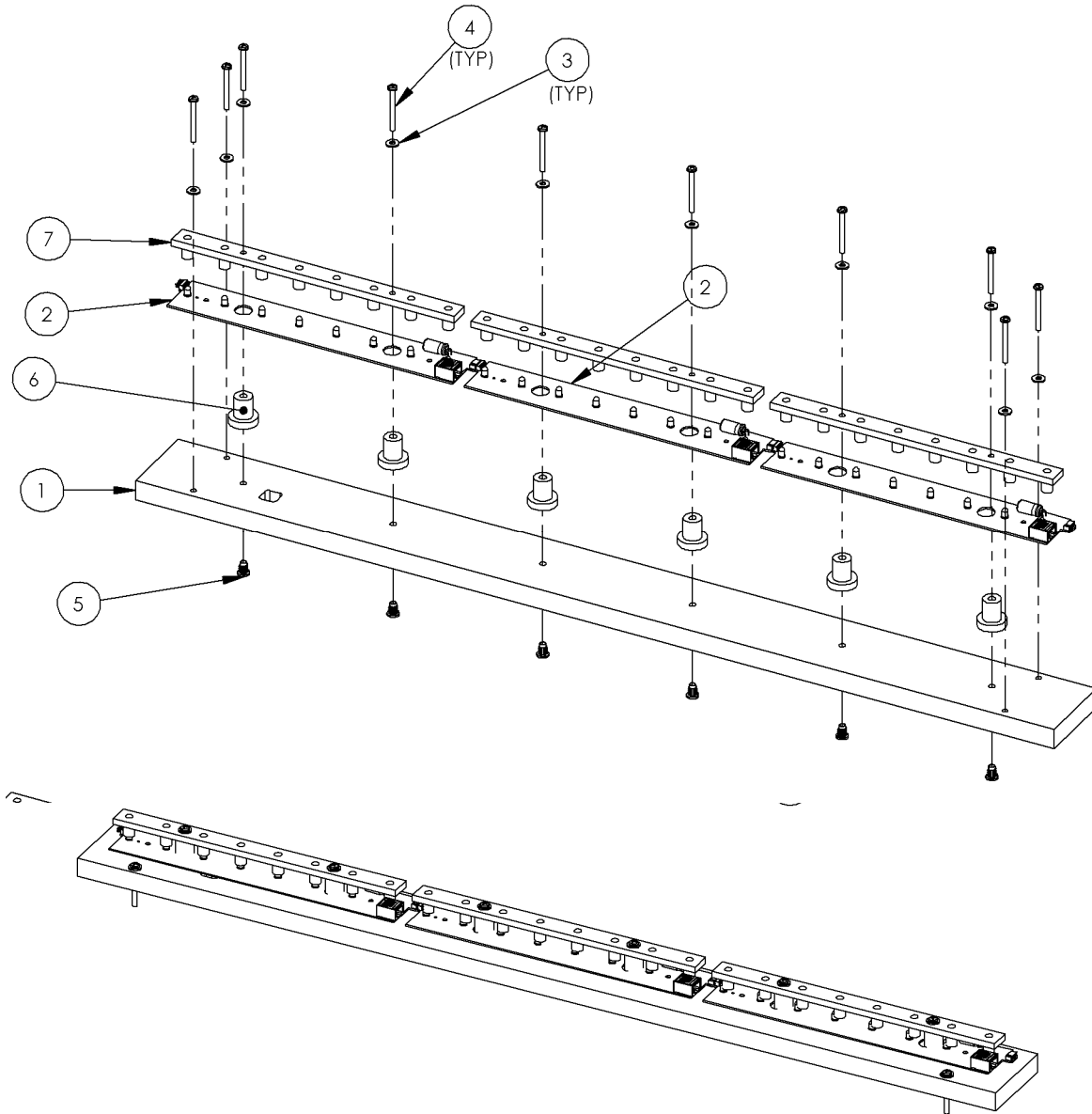

ITEM NO.	PART NO.	DESCRIPTION	QTY.
1	WC3075	BOARD PANEL	1
2	EBL01	3 BOARD LAYOUT	1
3	6031	#8 FLAT WASHER	10
4	6348	#8-32 X 1.75" PHMS	10
5	6061	#8-32 CABINET INSERT	6
6	WC4006	RUBBER PCB MOUNT	6
7	WC3020	SENSOR LIGHT CHANNEL	3

RIGHT/LEFT SIDE SENSOR REMOVAL

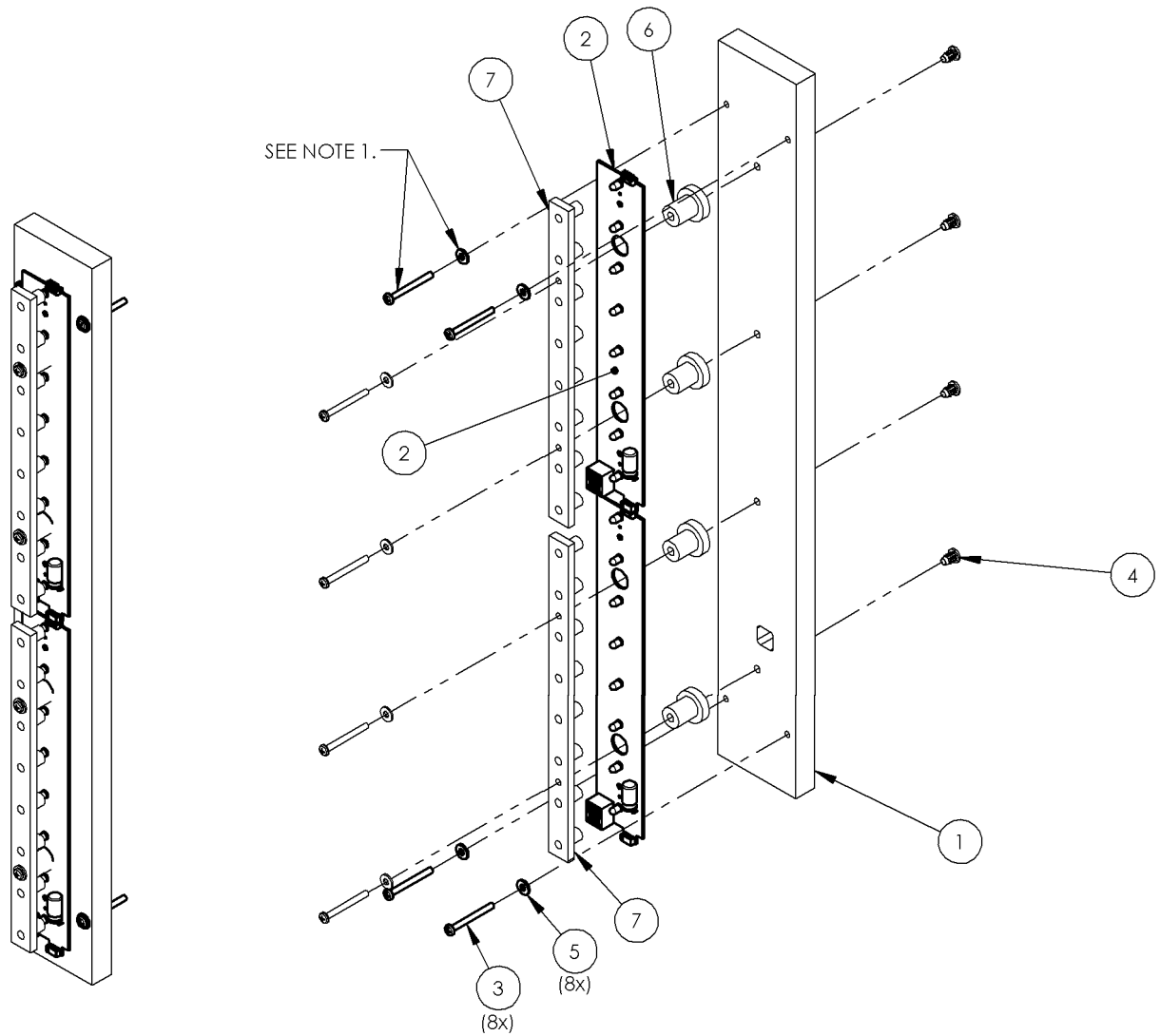

ITEM NO.	PART NO.	DESCRIPTION	QTY.
1	WC3076	SENSOR MOUNT BOARD SHORT	1
2	EBL01	2 BOARD LAYOUT	1
3	6348	#8-32 X 1.75" PHMS	8
4	6061	#8-32 CABINET INSERT	4
5	6031	#8 FLAT WASHER	8
6	WC4006	RUBBER PCB MOUNT	4
7	WC3020	SENSOR LIGHT CHANNEL	2

ELECTRICAL COMPONENTS

Rear view of cabinet—left side

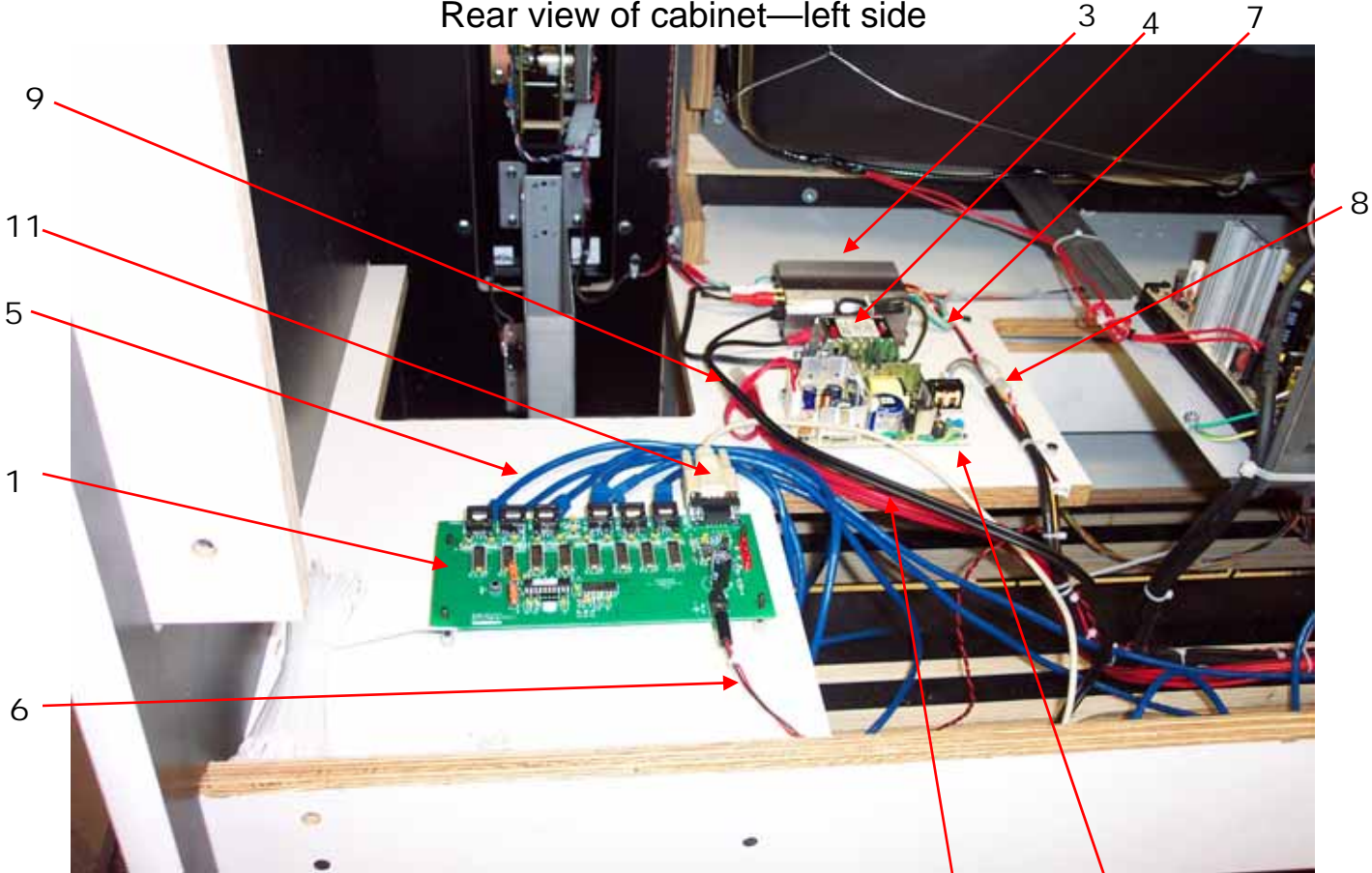

ITEM NO.	PART NO.	DESCRIPTION	QTY.
1	WC2013	I/O BOARD (SENSOR CONTROL BOARD)	1
2	CK2011	POWER SUPPLY	1
3	EV2009	AUDIO POWER AMP	1
4	2762	FILTER GROUND LOOP ISOLATOR	1
5	8702	7' PATCH CABLES (BLUE)	6
6	WC2059X	(PART OF) AUDIO AMP POWER	1
7	WC2053X	AUDIO SPEAKER HARNESS	1
8	WC2059X	(PART OF) AUDIO AMP POWER	1
9	2731	CABLE AUDIO Y ADAPTER	1
10	WC2071X	SENSORS POWER HARNESS	1
11	2247	6' MONITOR EXTENSION CABLE (9 PIN)	2 of 2

ELECTRICAL COMPONENTS

Rear view of cabinet—right side

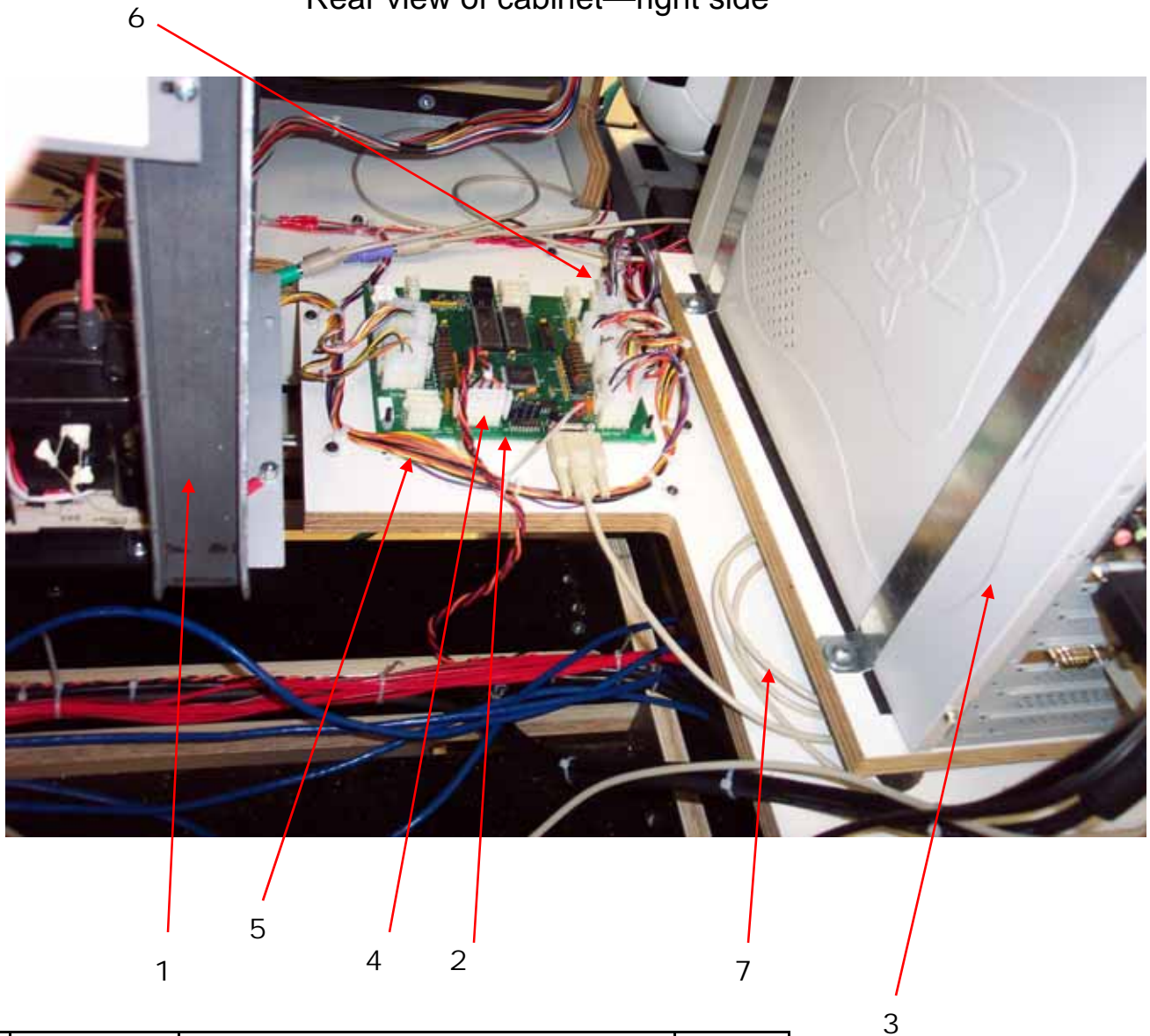

ITEM NO.	PART NO.	DESCRIPTION	QTY.
1	MON39TRIN	39" MONITOR	1
2	MB2034WCX	I/O MAIN BOARD	1
3	WC2000	COMPUTER	1
4	WC2062X	DC POWER HARNESS	1
5	WC2058X	TICKET DOOR / BUTTON HARNESS	1
6	WC2057X	COIN DOOR / DBV HARNESS	1
7	2247	6' MONITOR EXTENSION CABLE	1 of 2

PARTS LISTINGS

Misc. Parts

PP5001	Coin Door
WC3027	Monitor Glass
WC1001	Floor Ramp
WC4001	Goal Post Padding Top
WC4002	Goal Post Padding Left Side
WC4005	Goal Post Padding Right Side
WC4003	Rear Door Rug
WC4010	Shot Mat
WC4004	Astro Turf
KI3001	Soccer Ball
KI3002	72" Tether
N230-011	Tether Swivel

Electrical Parts

MB2034WCX	I/O Main Board
WC2013	PCBA Controller
WA2010	Power Supply 12v/5v
CK2011	Power Supply 15v
WC2012	TX Boards
WC2011	RX Boards
WC2014	Terminator Board
FG2007	Speaker
WC2000	Computer
DD2364X	Fan Assembly
MON39TRIN	39" Monitor
EV2009	Audio Power Amp
2289X	Reset Button Assembly
2762	Filter Ground Loop Isolator
8312	PL-40
PP250X	Socket
MZ8284X	Ballast Workhorse 6 Assembly
MZ2005	Button (4" Round) White
HR200	Button (2" Round) White
WC2005	Push Button (L & R)

Graphics and Decals

WC7001	Decal - Side Cabinet Upper L & R
WC7002	Decal - Side Cabinet Lower Left
WC7004	Decal - Side Cabinet Lower Right
WC7005	Decal - Power / Boost Button
WC7007	Decal - Left Button
WC7008	Decal - Right Button
WC7009	Decal - Select / Start Button
WC7012	Decal - Control Panel
WC7014	Decal - Soccer Ball
WC7016	Decal - Net Inside Left
WC7017	Decal - Net Inside Right
WC7018	Decal - Floor Graphic
WC7019	Decal - Flags Monitor Banner
WC7020	Decal - Speaker Cover
WC7027	Decal - Marquee
WC7028	Decal - Marquee Soccer Ball

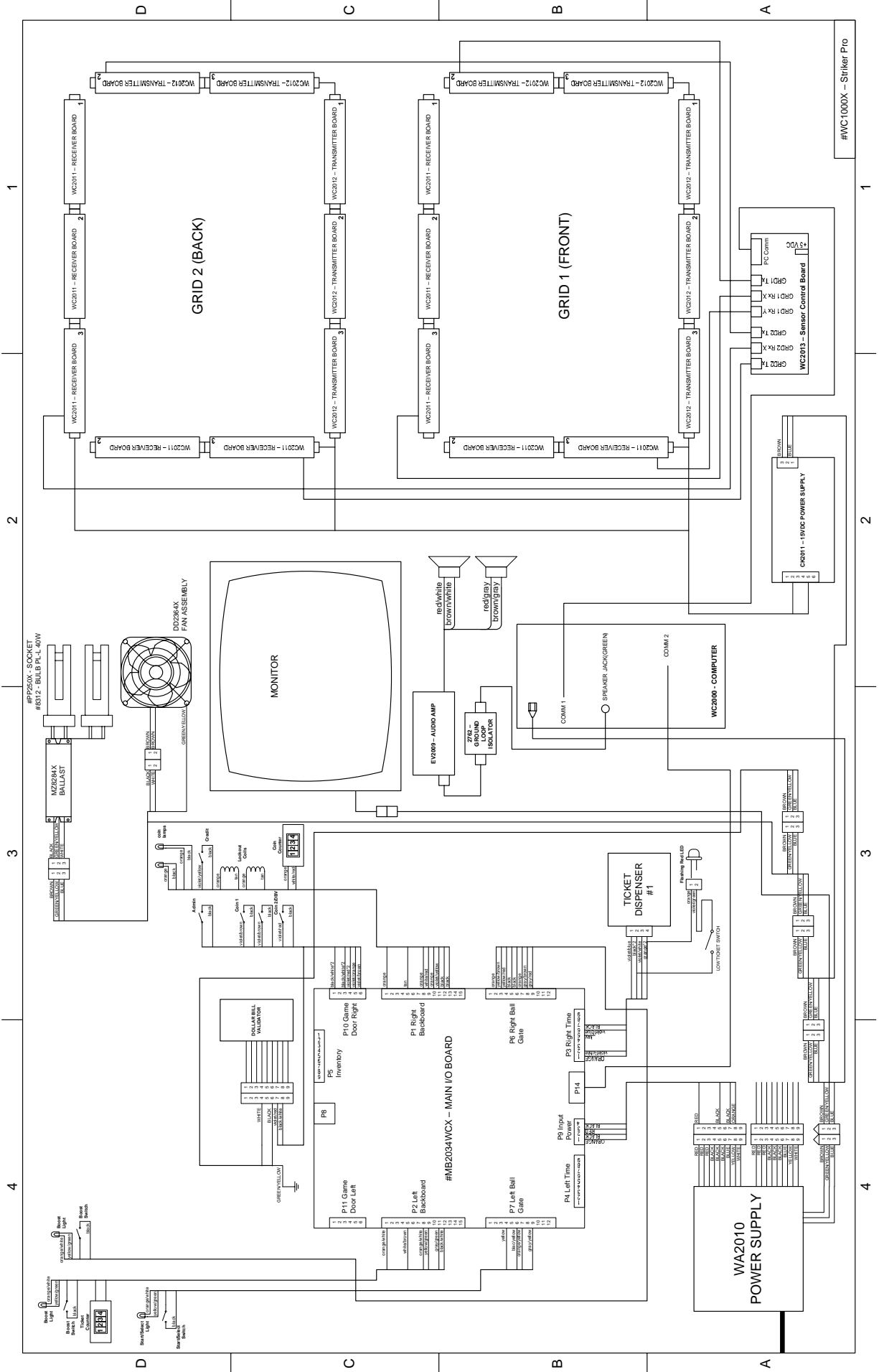

This page intentionally left blank.

Warranty

I.C.E warrants all components in the **Striker Pro™** game to be free of defects in materials and workmanship for a period of ninety days from the date of purchase.

This warranty does not cover items damaged due to normal wear and tear, subjected to abuse, improperly assembled by the end user, modified, repaired, or operated in a fashion other than that described in the service manual.

If your **Striker Pro™** game fails to conform to the above-mentioned warranty, I.C.E.'s sole responsibility shall be at its option to repair or replace any defective component with a new or remanufactured component of equal to or greater O.E.M. specification.

I.C.E. will assume no liability whatsoever, for costs associated with labor to replace defective parts, or travel time associated therein.

I.C.E.'s obligation will be to ship free of charge, replacement parts by U.P.S. Ground, U.S. mail, or other comparable shipping means. Any express mail or overnight shipping expense is at the cost of the purchaser.

Products will be covered under warranty only when:

- The serial number of the game with the defective parts is given. A tech number has been issued by an I.C.E. technical representative.
- The serial number of the defective part, if applicable, is given.
- Defective parts are returned to I.C.E., shipping pre-paid, in a timely fashion, if requested by I.C.E.
- A copy of the sales receipt is available as proof of purchase upon request of I.C.E.

I.C.E. distributors are independent, privately owned and operated. In their judgment, they may sell parts or accessories other than those manufactured by I.C.E. We cannot be responsible for the quality, suitability, or safety of any non-I.C.E. part, or any modification, including labor, which is performed by such a distributor.



WARRANTY

ICE Inc warrants that all of its products will be free from defects in material and workmanship.

When placing a warranty request, please be prepared to provide the following information:

- Serial Number of Game or Bill of Sale
- Machine Type
- A Detailed Description of the Equipment Fault Symptoms

ICE product, including Cromptons, Sam's Billiards, Uniana and Bell Fruit is warranted as follows:

- 180 days on the Main PCB and Computers
- 180 days on monitors
- 90 days on all other components (i.e. DBV's, Ticket Dispensers, sensors, etc)

ICE Inc shall not be obligated to furnish a warranty request under the following conditions:

- Equipment has been subjected to unwarranted stress through abuse or neglect
- Equipment has been damaged as a result of arbitrary repair/modification attempts
- Equipment that has failed through normal wear and tear

ICE Inc will assume no liability whatsoever for costs associated with labor to replace defective parts or travel time associated therein.

All defective warranty covered components will be replaced with new or factory refurbished components equal to OEM specifications. ICE Inc will cover all UPS ground, or comparable shipping means, freight costs during the warranty period. Expedited shipments are available for an additional charge.

Defective parts are returned to ICE Inc, at the customer's expense, in a timely fashion.

ICE distributors are independent, privately owned and operated. In their judgment, they may sell parts and/or accessories other than those manufactured by ICE Inc. We cannot be responsible for the quality, suitability or safety of any non-ICE part, modification (including labor) that is performed by such a distributor.

I.C.E. Parts/Service Dept.
Innovative Concepts in Entertainment
10123 Main St.
Clarence, NY 14031
Phone #: (716) - 759 - 0360
Fax #: (716) - 759 - 0884