

# SEGA®



TWIN DRIVING CABINET



## SERVICE MANUAL



- Before using this product, read this **MANUAL** carefully to understand the contents stated herein.
- After reading this **MANUAL**, be sure to keep it available nearby the product or somewhere convenient in order to be able to refer to it whenever necessary.

Manufactured in the UK by

# SEGA

Amusements Europe Limited



## BEFORE USING THIS PRODUCT

To ensure the safe usage of the product, be sure to read the following before using the product. The following instructions are intended for the use of QUALIFIED SERVICE PERSONNEL ONLY. After carefully reading and sufficiently understanding the instructions should any activity be carried out on the product. Only qualified service personnel should carry out maintenance on the product.

Terms such as WARNING!, CAUTION, and IMPORTANT! Are used where an explanation is given which requires special attention, depending on the potential risk. SEGA is not responsible for injury or damage caused by use in a manner contrary to the instructions stated in this document. In order to prevent accidents warning stickers and printed instructions are applied in the places where a potentially hazardous situation relating to the product could arise. Be sure to comply with these warnings.



Indicates that mishandling the product by disregarding this warning will cause a potentially hazardous situation which can result in death or serious injury.



Indicates that mishandling the product by disregarding this caution will cause a potentially hazardous situation which can result in personal injury and or material damage.



This is cautionary information which should be complied with when handling the product. Indicates that mishandling the product by disregarding this will cause a potentially hazardous situation which may not result in personal injury but could damage the product.

- **Perform work in accordance with the instructions herein stated.**

Instructions for work are explained by paying attention to the aspect of accident prevention. Failing to perform work as per the instructions can cause accidents. In the case where only those who have technical expertise should perform the work to avoid hazardous situations, the instructions herein state that the service person(s) should perform such work.

- **Be sure to turn off power before working on the machine.**

To prevent electrical shock, be sure to turn off power before starting work in areas in which which the service person(s) touches the interior of the product. If the work has to be performed with the power-on status, the instructions herein will state that only a qualified service person(s) should perform such work.

- **Ensure that the Power Supply used is equipped with an Earth Leakage Breaker.**

This product does not incorporate an Earth Leakage Breaker. Using a power supply which is not equipped with an Earth Leakage Breaker may cause a fire or serious injury.

- **Be sure to use fuses which meet the specified rating.**

Using fuses exceeding the specified rating can cause a fire and / or cause an electric shock.

- **Specification changes, removal of equipment, conversion and/or addition, not designated by SEGA are not permitted and will invalidate this product's CE conformity.**

The parts of the product also include any warning labels or safety covers for personal protection etc. A potential hazard will be created if the machine is operated while any parts have been removed. Should any doors, lids or protective covers be damaged or lost, do not operate the product. SEGA is not liable in any whatsoever for any injury and/or damage caused by specification changes not designated by SEGA.

- **When handling the monitor, be very careful. (Applies only to product with monitor).**

Some of the monitor (TV) parts are subject to high tension voltage. Even after turning off the power some components are still occasionally subject to high tension voltage. Monitor repair and replacement should be performed by qualified service engineers only.

- **Install and operate the machine only in places where appropriate lighting is available, allowing warning stickers to be clearly read.**

To ensure maximum safety for both customers and operators, stickers and printed instructions describing potentially hazardous situations are applied to places where accidents could occur.

Ensure that where the product is operated has sufficient lighting to allow any warnings to be read. If any sticker or printed warning is removed or defaced, do not operate the machine, until it has been replaced by an identical item.

Before installing the product, check for the Electrical Specification Sticker, SEGA products have a sticker on which the electrical specifications are detailed. Ensure that the product is compatible with the power supply voltage and frequency requirements of the location in which the machine is to be installed.

When installing this equipment ensure the socket outlet is near the machine and is easily accessible.

In cases where commercially available monitors and printers are used only the contents relating to this product are stated in this manual. Some commercially available equipment has functions and reactions not stated in this manual. Read this manual in conjunction with the specific manual of such equipment.

Descriptions contained herein may be subject to change without prior notification.

The contents described herein are fully prepared with due care. However, should any question arise or errors be found please contact SEGA.

INSPECTION IMMEDIATELY AFTER TRANSPORTING THE PRODUCT TO LOCATION
---

Normally, at the time of shipment, SEGA products are in a state which allow for immediate usage after transportation to location. Nevertheless, an irregular situation may occur during transportation. Before applying power to the product, check the following points to ensure that the product has been transported in a satisfactory status.

- Is there any external damage to the machine i.e. dents, cuts or cracks?
- Are the castors or leg adjusters damaged?
- Do the power supply voltage and the frequency of the machine meet the requirements of the location?
- Are all wiring connectors correctly connected and secure?
- Are the power cables undamaged?
- Do the fuses meet the specified rating?
- Are all accessories available?
- Can all doors be opened and closed and locked with the keys provided?

# CONTENTS

SPECIFICATIONS .....	1
INTRODUCTION TO THIS MANUAL .....	1
1. HANDLING PRECAUTIONS .....	3
2. PRECAUTIONS REGARDING LOCATION AND INSTALLATION .....	5
3. OPERATION .....	7
4. NAME OF PARTS .....	9
5. ACCESSORIES .....	10
6. FUSES .....	11
7. ASSEMBLING WITH PRECAUTIONS .....	12
8. PRECAUTIONS TO BE TAKEN WHEN MOVING THE MACHINE .....	23
9. BASIC CONTENTS OF THE GAME .....	24
10. EXPLANATION OF TEST AND DATA DISPLAY .....	25
10.1. VTS BOARD – SWITCHES AND COIN COUNTER .....	26
10.2. TEST MODE .....	27
10.3. SYSTEM INFORMATION .....	28
10.4. UGCI TEST .....	29
10.5. INPUT TEST .....	30
10.6. CALIBRATION TEST .....	31
10.7. OUTPUT TEST .....	32
10.8. COIN TEST .....	33
10.9. SOUND TEST .....	34
10.10. CRT TEST .....	35
10.11. DRIVE BOARD TEST .....	36
10.12. BOOKKEEPING .....	37
10.13. CLOCK SETTINGS .....	40
10.14. NETWORK TEST .....	41
10.15. GAME TEST MODE .....	42
11. HOW TO PLAY .....	43
12. UPGRADES .....	54
13. HANDLE MECHANISM .....	55
13.1. REMOVING THE CONTROL PANEL .....	55
13.2. REPLACING AND ADJUSTING THE HANDLE'S V.R. ....	56
13.3. GREASING .....	57
14. SHIFT LEVER .....	58
14.1. REMOVING THE SHIFT LEVER .....	58
14.2. SWITCH REPLACEMENT .....	59
15. ACCELERATOR & BRAKE .....	60
15.1. ADJUSTING AND REPLACING THE V.R. ....	60
16. COIN SELECTOR .....	62
17. MONITOR .....	63
17.1. CAUTIONS CONCERNING THE SAFETY ISSUES WHEN HANDLING THE MONITOR .....	63
17.2. CAUTIONS TO BE AWARE OF WHEN CLEANING THE CRT SURFACES .....	64
17.3. ADJUSTING THE PICTURE .....	65
18. REPLACEMENT OF FLUORESCENT LAMPS .....	66
19. REPLACEMENT OF BUTTON LAMPS .....	68
20. GAME BOARD .....	70
20.1. REMOVING THE GAME BOARD .....	70
20.2. GAME BOARD CONNECTIONS .....	72
21. NETWORK PLAY .....	74
21.1. CONNECTIONS FOR NETWORK PLAY .....	76
21.2. NETWORK PLAY SETTINGS .....	77
22. COIN SETTINGS .....	78
22.1. VTS CREDIT BOARD OPTION SETTINGS .....	80
22.2. PRICE OF PLAY SETTINGS UK .....	81
22.3. PRICE OF PLAY SETTINGS EURO .....	83
23. DESIGNED RELATED PARTS .....	84
24. PARTS LIST .....	85
24.1. TOP ASSY FORD RACING TWIN – FR00001UK .....	86
24.2. ASSY MAIN 1P – FR-10001UK .....	87
24.3. ASSY CONTROL PANEL – FR-2000UK .....	89
24.4. ASSY HANDLE MECHA – FR-2500UK .....	90

24.5.	ASSY SW PLATE – FR-2100UK.....	91
24.6.	ASSY HEADER – FR-0200UK.....	92
24.7.	ASSY POP – FR-0270UK .....	92
24.8.	ASSY FAN UNIT DC – HDT-1530UK .....	93
24.9.	ASSY SEAT TWIN 1P – FR-5000UK.....	94
24.10.	ASSY SEAT CABI – FR-5500UK .....	94
24.11.	ASSY SEAT UNIT – FR-5600UK .....	95
24.12.	ASSY AC BRKT MAIN – FR-0400UK .....	96
24.13.	ASSY AC BKT SUB – FR-0700UK .....	96
24.14.	ASSY PEDAL BASE L – FR-1100UK .....	97
24.15.	ASSY PEDAL BASE R – FR-1150UK.....	97
24.16.	ASSY BRAKE & ACCEL – SPG-2200 .....	98
24.17.	ASSY MAIN BD PC MASTER – FR-4500UK.....	100
24.18.	ASSY MAIN BD PC SLAVE – FR-4600UK .....	101
24.19.	ASSY COINCHUTE TOWER .....	102
24.20.	ASSY INSTALLATION KIT FR TWIN – FR-INST-TW.....	103
25.	APPENDIX A - ELECTRICAL SCHEMATIC .....	104
25.1.	WIRE COLOURS .....	104
25.2.	ELECTRICAL SCHEMATIC .....	104

## SPECIFICATIONS

Installation space:	250cm (W) x 250cm (D)
Height:	217cm
Depth:	178cm
Width:	171cm
Weight:	500kgs (approx)
Rating:	3.5A MAX
Monitor type:	SANWA 29" PFX FST
Monitor Operational Voltage:	230vac – 240vac
Display output:	RGB
Operational Voltage	220vac – 240vac
Power Consumption	800W MAX

## INTRODUCTION TO THIS MANUAL

This Owners Manual is intended to provide detailed descriptions together with all the necessary information covering the general operation of electronic assemblies, electro mechanicals, servicing control, spare parts, etc. as regards to the product **FORD RACING TWIN – FULL BLOWN**.

This manual is intended for the owners, personnel and managers in charge of the operation of this product. Only operate the product after carefully reading and sufficiently understanding the instructions. If the product fails to function satisfactorily, non-technical personnel should under no circumstances touch the internal workings of this machine. Please contact where the product was purchased.

### SEGA AMUSEMENTS EUROPE LIMITED

Suite 3a, Oaks house.  
12-22 West Street,  
Epsom.  
Surrey.  
KT18 7RG

Tel: +44 (0) 1372 731820  
Fax: +44 (0) 1372 731849

## DEFINITION OF THE QUALIFIED SERVICE ENGINEER AND MAINTENANCE PERSONEL



Non-technical personnel who do not have technical knowledge and expertise should refrain from performing such work that this manual requires. Only QUALIFIED SERVICE ENGINEERS should carry out work either inside or outside the compass of this manual. Failure to comply with this instruction may cause a severe accident or even death.

Ensure that all service, inspection repair work and troubleshooting is carried out by a QUALIFIED SERVICE ENGINEER.

All other work i.e. cleaning and general upkeep of the machine (supplying data cards, repairing coin jams or re-booting a machine) can be carried out by the LOCAL MAINTENANCE PERSONEL.

### “QUALIFIED SERVICE ENGINEER”

Those who participate in the design, manufacture, inspection, maintenance or service of equipment at an amusement equipment manufacturer.

Those who have technical expertise with qualified certification regarding electricity, electronics and or mechanical engineering and take part in a daily service and control of amusement equipment.

### “LOCAL MAINTENANCE PERSONEL”

Those who have experience in maintenance of amusements equipment and or vending machines and also participate in daily routine work of general maintenance of the product.

## 1. HANDLING PRECAUTIONS

When installing or inspecting the machine, be very careful of the following points and pay attention to ensure that the player can enjoy the game in safety.

Non-compliance with the following points or inappropriate handling running counter to the cautionary matters herein stated can cause personal injury or damage to the machine.



- Before performing the work, be sure to turn the power off. Performing the work without turning off the power can cause electric shock or short circuit. In the case where work should be performed in the status of power on, this manual will state to that effect.
- To avoid electric shock or short circuit, do not apply or disconnect power to the machine in a quick or haphazard manner.
- To avoid electric shock, do not apply power to the machine with wet hand(s).
- Do not expose Power Cords or Earth Wires on the surface, (floor, passage, etc.) If exposed, the Power Cord or Earth Wires are susceptible to damage. Damaged Cords or Wires can cause an electric shock or short circuit which may lead to a fire hazard.
- To avoid causing a fire and or electric shock, do not put objects on Power Cords or Earth Wires.
- When or after installing the product, do not unnecessarily pull the Power Cord. If damaged the Power Cord may cause an electric shock and or fire hazard.
- In case the Power Cord is damaged, ask for a replacement through where the product was purchased or the office stated herein. Using a damaged Power Cord can cause an electric shock or fire hazard.
- Be sure to perform correct earth checks and make sure that the machine is correctly earthed. Inappropriate earthing of the product may cause electric shock or fire hazard.
- Be sure to use fuses which meet the specified rating. Using fuses which exceed the specified rating can cause electric shock, short circuit and or fire hazard.
- Ensure all connections are made fully. Connections which are not fully made may cause electric shock or fire hazard.
- To avoid causing a fire hazard or an electric shock, do not make any unspecified changes to the product by replacing or changing parts or components without the express consent of SEGA.
- Be sure to make periodic maintenance checks as stated herein.



- Only a QUALIFIED ELECTRONICS ENGINEER is allowed to perform IC BOARD inspection or analysis using a LOGIC ANALYSER. The use of a MULTIMETER is not permitted on IC BOARDS.
- When cleaning the CRT surfaces, use a soft dry cloth. Do not apply chemicals such as thinners, benzene, etc.
- The electronic parts on the IC BOARD could be damaged due to human body static electricity. Before performing IC BOARD related work, be sure to discharge physically accumulated static by discharging on a grounded metallic surface.



## CONCERNING THE STICKER DISPLAY

SEGA product has stickers describing the product manufacture number (Serial Number) and electrical specification. If you require service assistance you will require the Serial Number. Identical machines may have different parts fitted internally. Only by quoting the Serial Number will the correct parts be identified.

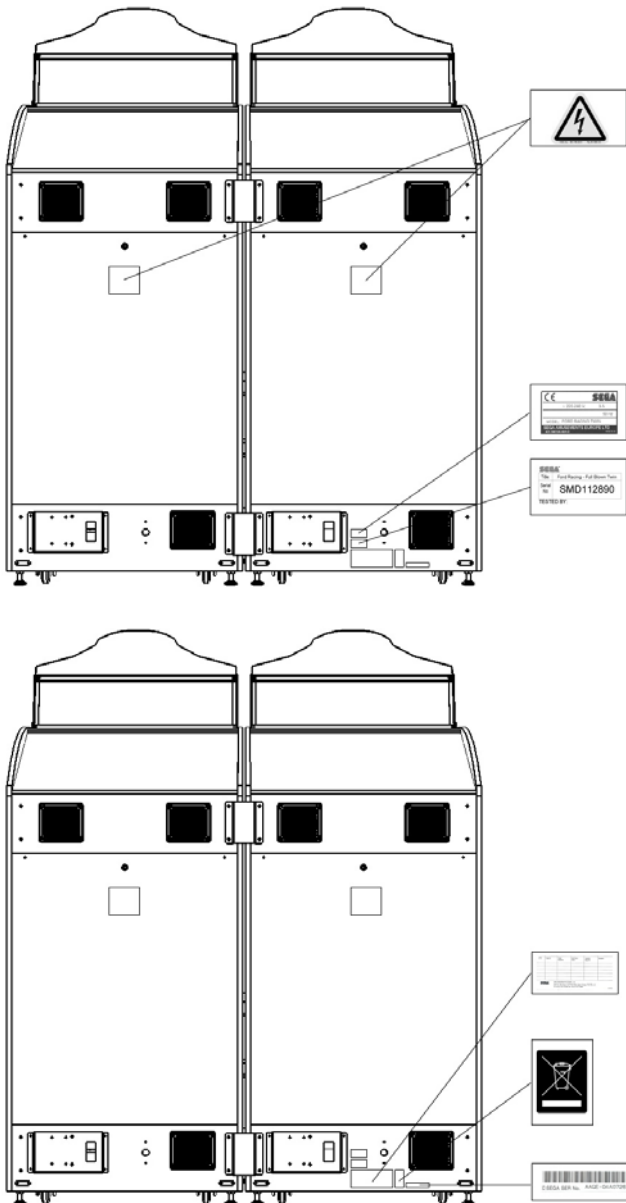

## CONCERNING WARNING STICKERS

SEGA product has warning displays on stickers, labels or printed instructions adhered/attached to or incorporated in the places where hazardous situations can arise. The warning displays are intended for the accident prevention of customers and service personnel.

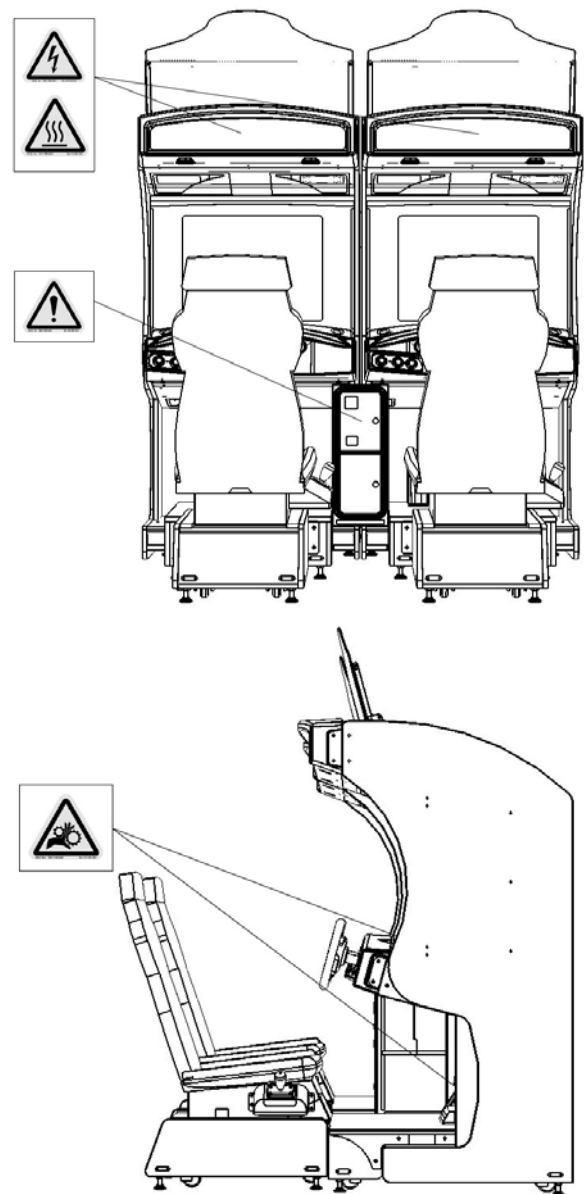

## 2. PRECAUTIONS REGARDING LOCATION AND INSTALLATION



This product is an indoor amusement machine. Do not install it outside. Even indoors, avoid installing in places mentioned below so as not to cause a fire, electric shock, injury and or malfunction.

- Places subject to rain or water leakage, or places subject to high humidity in the proximity of an indoor swimming pool and or shower, bath etc.
- Places subject to direct sunlight, or places subjected to high temperatures such as in the vicinity of heating units, etc.
- Places filled with inflammable materials or chemicals or any hazardous matter.
- Dusty places.
- Sloped surfaces.
- Places subjected to any type of violent impact.
- Vicinity of anti-disaster facilities such as fire escapes and fire extinguishers.
- The operating (ambient) temperature range is from 5 degrees centigrade to 40 degrees centigrade. Only in the cases where a projector is employed then the temperature drops from 40 to 30 degrees centigrade.

### LIMITATIONS OF USAGE REQUIREMENTS



- Be sure to check the electrical specifications. Ensure that this product is compatible with the locations power supply voltage and frequency requirements. A plate describing the electrical specifications is attached to the product. Non-compliance with the electrical specification can cause fire or electrical shock.
- This product requires a RCD as part of the location facilities. Using them in a manner not independent can cause an electric shock or a fire.
- Ensure that the indoor wiring for the power supply is rated at 7A or higher in areas using 220 – 240VAC. Non-compliance with this may cause electric shock or a fire.
- Be sure to independently use the power supply equipped with an Earth leakage breaker. Using a power supply without an Earth leakage breaker can cause a fire when earth leakage occurs.
- Putting many loads on one electrical outlet can cause a generation of heat and a fire may result from an overload.
- When using an extension cord, ensure that the cord is rated at 7A or higher. Using a cord rated lower than the specified rating may cause a fire or electric shock.



- Note that for transporting the machine to location the minimum necessary dimensions required for opening (of doors, etc.) are 1.85M x 1.05M (without shipping pallet.).
- For the operation of this machine, secure a minimum area of 2.5M x 2.5M. For ventilation, provide an approximately 20cm space between the rear part of the cabinet and the wall.

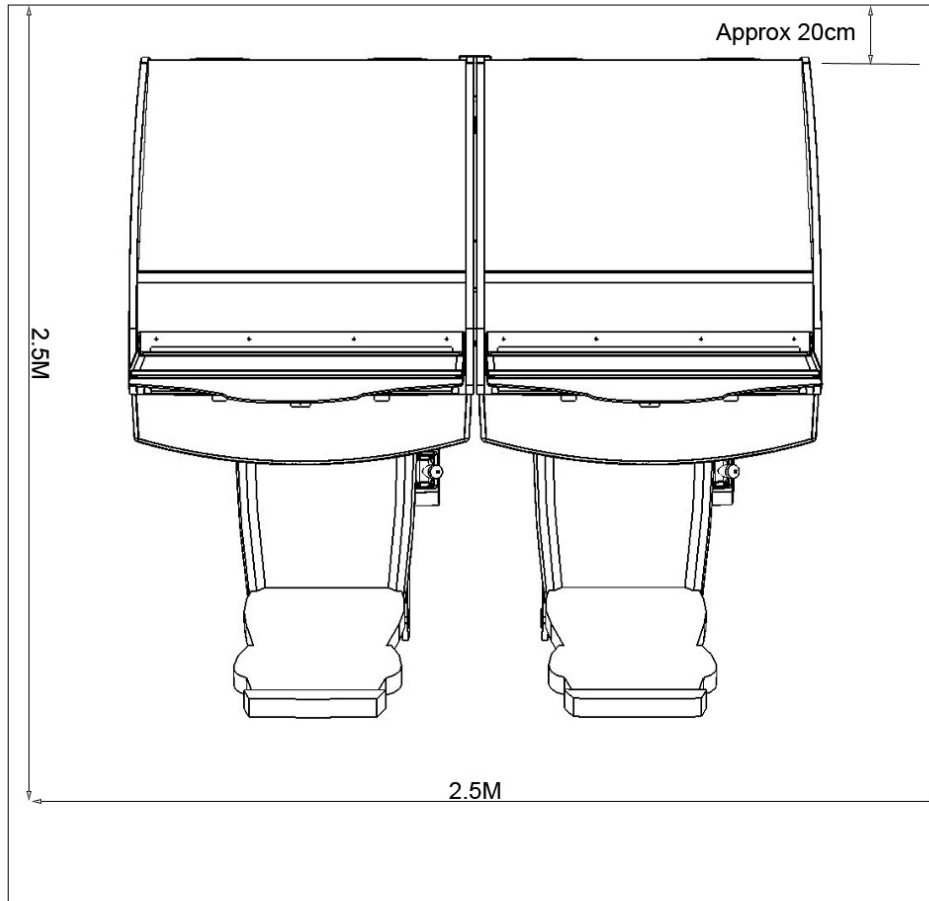

### 3. OPERATION

#### PRECAUTIONS TO BE HEDED BEFORE STARTING OPERATION

To avoid injury be sure to constantly give careful attention to the behaviour and manner of players and spectators.



In order to avoid accidents, check the following before starting operation.

- Check if all of the adjusters are in contact with the surface. If they are not, the cabinet may move and cause an accident.

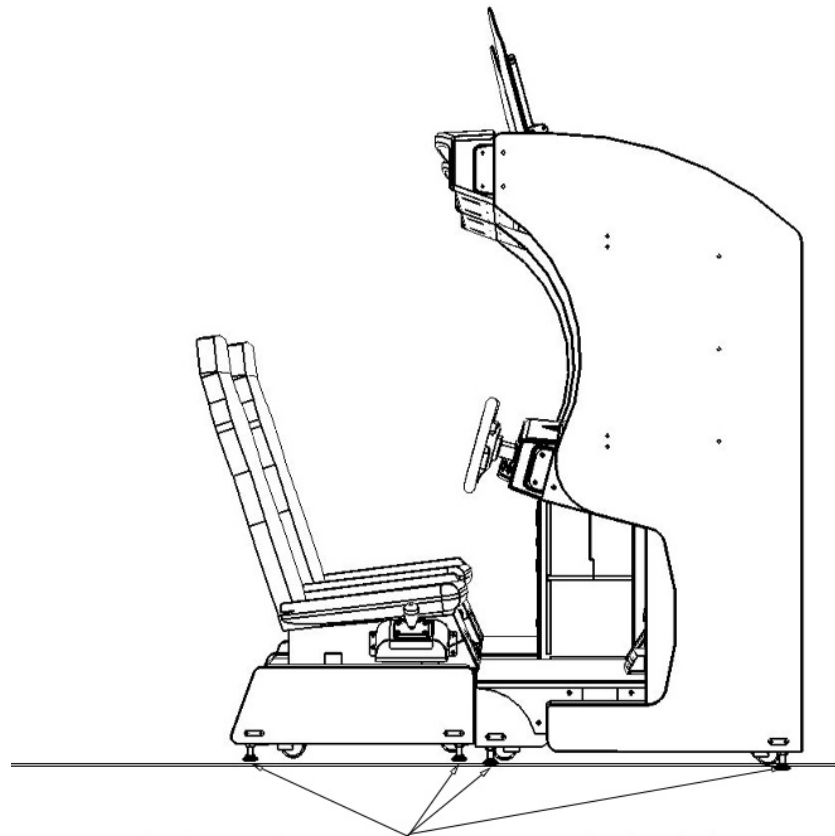

Ensure that all of the Adjusters are in contact with the floor.

- Do not put any heavy item on this product. Placing any heavy item on the product can cause accidental injury.
- Do not climb on this product. Climbing on this product can cause an accident or injury. To check the upper most part of this product, please use a step.
- To avoid electric shock, short circuit or damage, do not put the following items in the periphery of this product.

Flower vases, flowerpots, cups or any vessels which can contain water or chemicals.



To avoid injury, be sure to provide sufficient space by considering the potentially crowded situation at the installation location. Insufficient installation space can cause the player to come into contact with other resulting in injury.

## PAYING ATTENTION TO CUSTOMERS

To avoid injury or confrontation between customers, be sure to constantly give careful attention to the behaviour and manners of the players and visitors.



- To avoid electric shock and or short circuit, do not allow customers to put hands or fingers or any other extraneous matter into the openings of the product.
- To avoid injury from items falling from the machine, immediately stop customers from either putting items on top of the product or leaning against or climbing on the product.
- To avoid electric shock and or short circuit, do not allow customers to unplug the power cause at any cause.
- To avoid injury resulting from items falling from the machine, instruct the player not to place items or drinks onto the product.



- Immediately stop such violent acts as hitting or kicking the product. Such violent acts can cause damage to the product or injury to the player or observer.



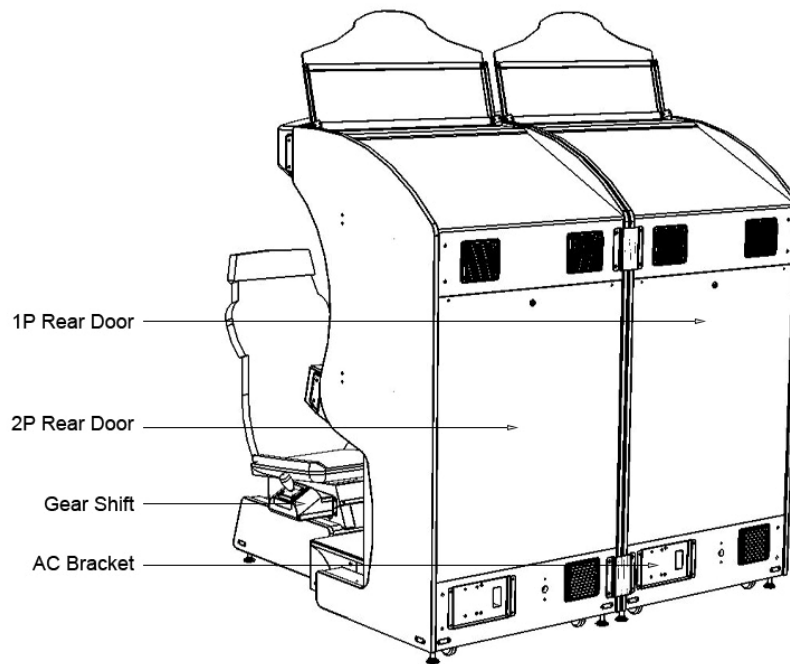
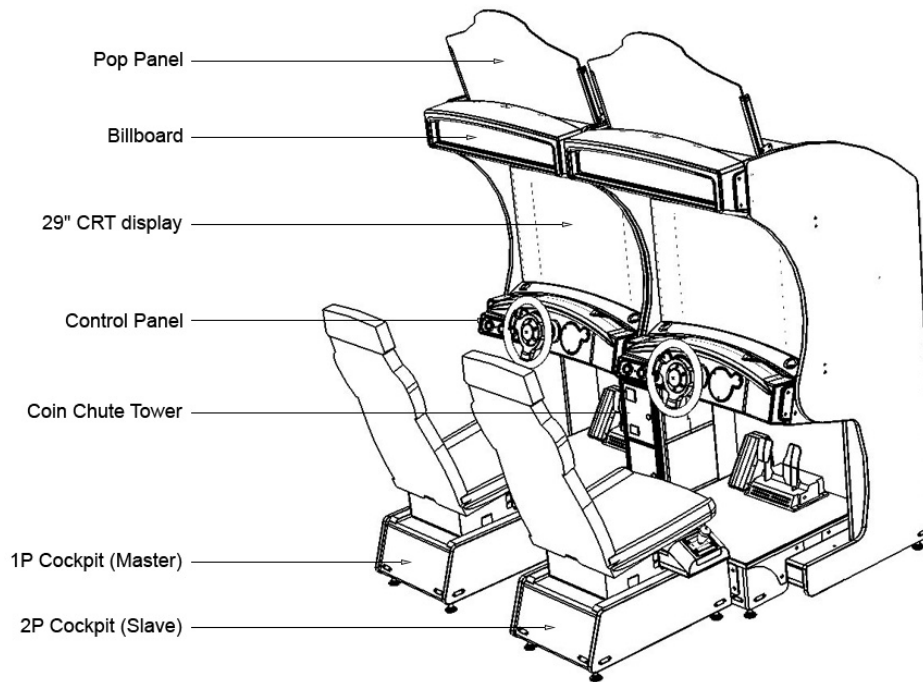





#### 4. NAME OF PARTS

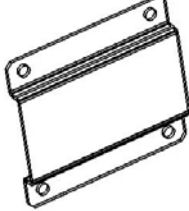

	Width	Depth	Height	Weight
Cockpit (per seat)	852mm	1630mm	1790mm	
Coin Chute Tower	220mm	300mm	550mm	15kg
Pop Panel	800mm	-	430mm	
When Assembled	1713mm	1624mm	2200mm	

## 5. ACCESSORIES

When transporting the machine to location, make sure that the following parts are supplied.

 <p><b>KEYS MASTER 9117</b> <i>For opening and closing service doors</i></p>	 <p><b>KEY TO DIFFER</b> <i>For opening and closing secure door</i></p>	 <p><b>SERVICE MANUAL FR</b> <i>This Manual</i></p>
<p>PT No 220-5575UK</p>	<p>PT No 220-5574-110UK</p>	<p>PT No: 420-FRSM-02UK</p>
 <p><b>SERVICE MANUAL SANWA</b> <i>Sanwa CRT Service Manual</i></p> <p>PT No: 420-5827-91UK</p>	 <p><b>JOINT BKT REAR X 2</b> <i>For adjoining the two Display cabinets</i></p> <p>PT No: FR-0013UK</p>	 <p><b>POWER CORD EUROPE</b> <i>Used for applying power to the machine in Europe (not UK)</i></p>
 <p><b>POWER CORD UK</b> <i>Used for applying power to the machine in UK</i></p>	 <p><b>NETWORKING CABLE 5MTRS</b> <i>Used to for linking up more that one twin cabinet</i></p> <p>PT No: 600-7269-0500UK</p>	 <p><b>STICKER C EPILEPSY</b> <i>Apply to a visible area using the location language</i></p> <p>PT No: 440-CS0186UK</p>

## 6. FUSES



- Never touch places other than those specified. Touching places other than those specified can cause electric shock or short circuit. Disconnect the machine from the supply before attempting the replacement of any fuse.



- Only QUALIFIED PERSONNEL should replace fuses.
- Only replace fuses with ones of the same value and type.

Part Number	Location	Description
514-5078-3150	RND-838-001 FUSE BD CAB 1&2	3.15A T CERAMIC 20MM
514-5078-5000	RND-838-001 FUSE BD CAB 2	5A T CERAMIC 20MM
514-5078-10000	FR-0400UK AC BRKT	10A T CERAMIC 20MM
514-5079-3000	FR-838-001UK MOTOR CONT BD	3A SLO-BLO GALSS 32MM
514-XXXX-5000	838-CA-150 AUDIO AMP	5A AUTO FUSE

There are also fuses located on the Monitor PCB. Please refer to the separate Monitor manual supplied to reference these fuses.



## 7. ASSEMBLING WITH PRECAUTIONS



- Perform assembly work by following the procedure herein stated. Failing to comply with the instructions can cause electric shock.
- Assembling should be performed as stated in this manual. Since this is a complex machine, erroneous assembling can cause electric shock, machine damage and or impair functionality.
- When assembling, be sure to be accompanied by another person. Depending on the work involved – there are some cases where two people are required. If only one person carries out the work alone, then it is possible that injury may occur, or damage to the product.
- Ensure that all connectors are accurately connected. Incomplete connections may cause electric shock or fire hazard.

When carrying out the assembly work, follow the procedure as laid out in this manual. Do not skip any stages as injury may occur if the machine is not installed in the correct sequence.

1. **Assembling 1 and 2 player cockpit.**
2. **Securing the machine into location.**
3. **Installing the Pop panel.**
4. **Installing Power Cables.**
5. **Turning power ON.**
6. **Assembly check.**

When assembling, make sure that tools such as a Phillips type screwdriver, wrench (for M16 hex) and a socket wrench to suit M8 (13mm) are available.

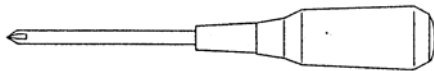

Phillips type screwdriver

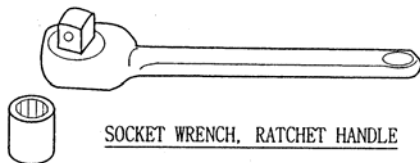

SOCKET WRENCH, RATCHET HANDLE

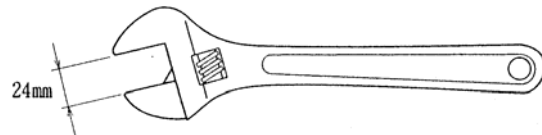

WRENCH (for M16 hexagon bolt)



- Only tighten fixings when all fixings are in place. If the fixings are tightened as the work progresses, it might not be possible to align the final fixings.

## 1 ASSEMBLING 1 AND 2 PLAYER COCKPITS

Step 1.  
Place the two cockpits side by side so that the artwork is facing outwards on both units. The 1P cabinet has the power cord at the left hand side as viewed facing the monitor.

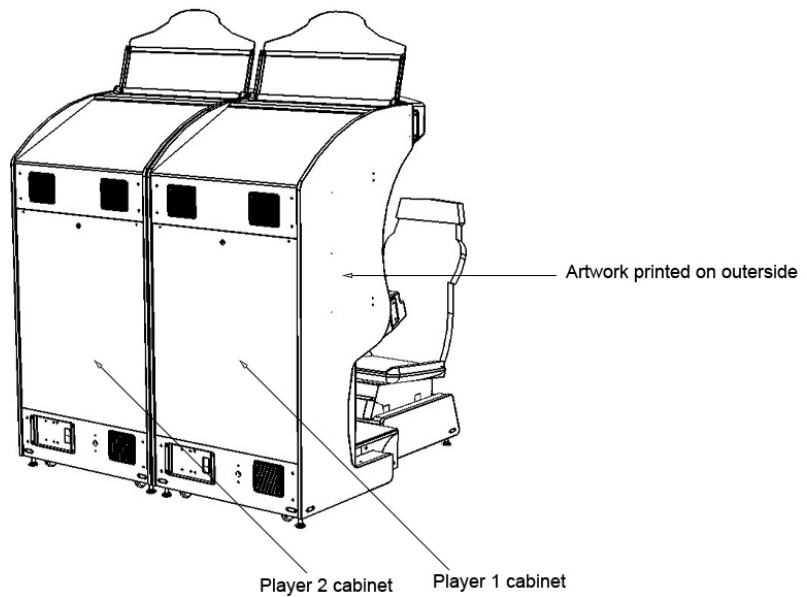

Step 2.  
Install the coin chute tower in between both cabinets. Open both coin doors and remove the cash box and the cash box base plate.

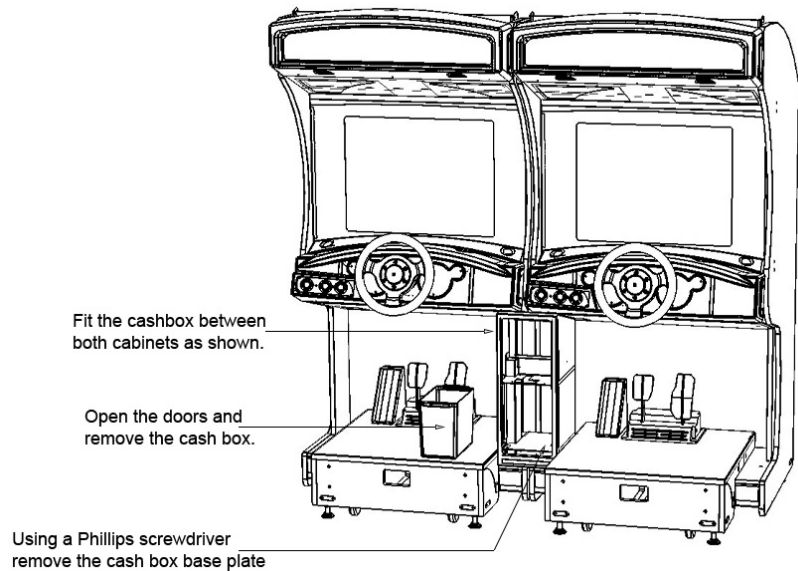

Step 3.  
 Making sure that there are no trapped wires, make the 4 (four) connections between both Master and Slave cabinets.

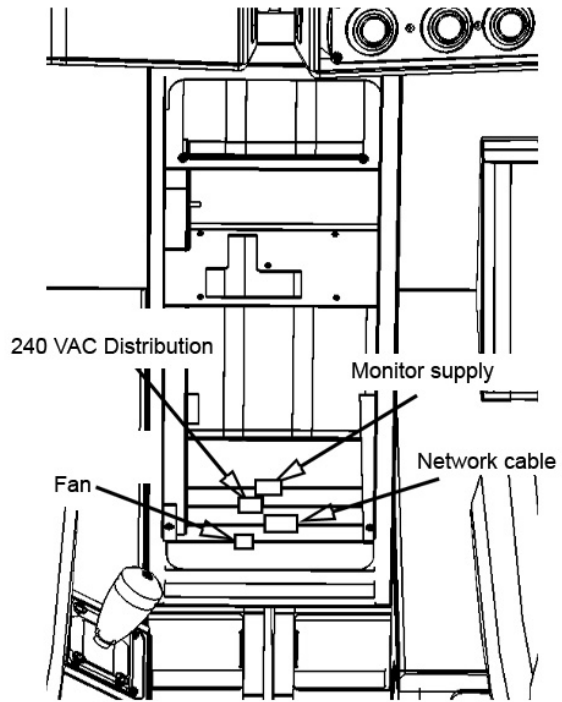

Step 4.  
 Make the remaining 4 (four) connections between the Coin Tower and Master and Slave units.

Connect the 2 Earth ring terminals to the M4 stud on the floor of the Coin Tower and secure.

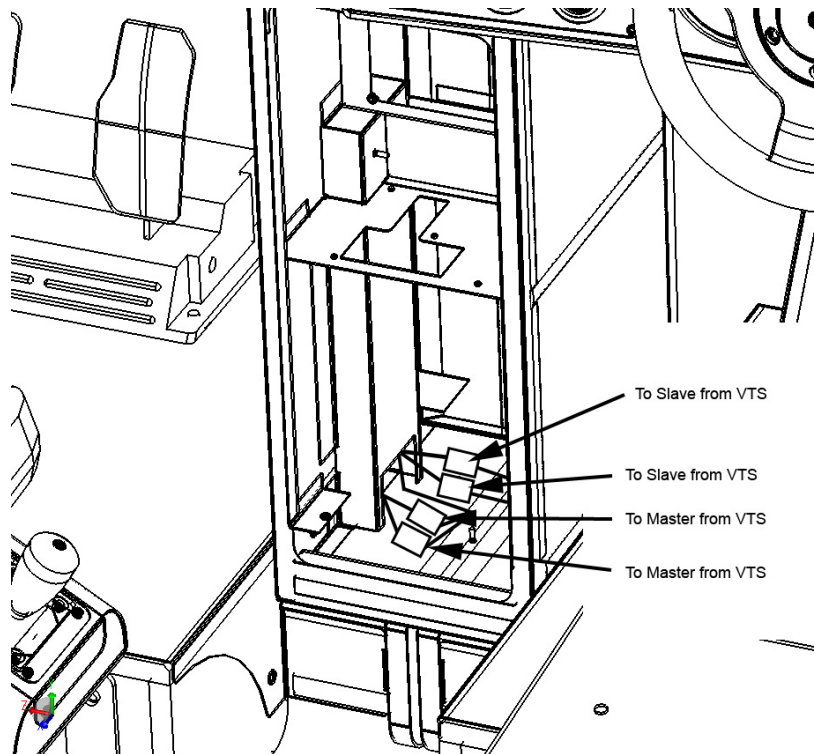

Step 5.  
Fix the coin tower to both cabinets by applying 8x M8x30 Hex Bolts (supplied) to the integral part of the tower.

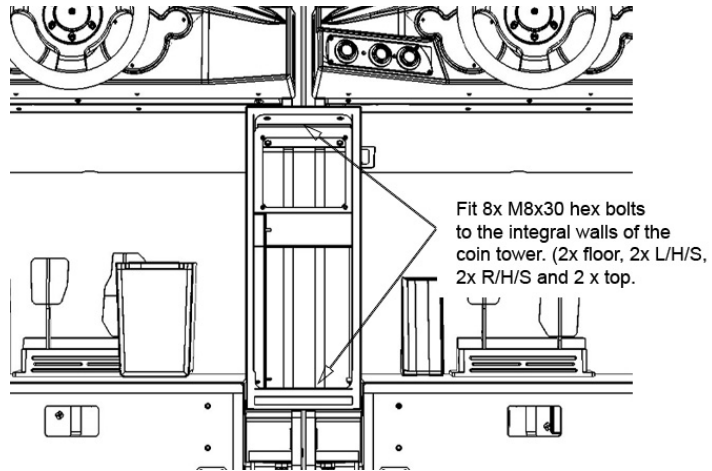

Step 6.  
Fit and secure the remaining 2x M8x30 Hex Bolts into the Coin Tower from inside both machines as show.

Fit and secure the remaining 2x M8x30 hex bolts through the inner self into the Coin Tower where shown.

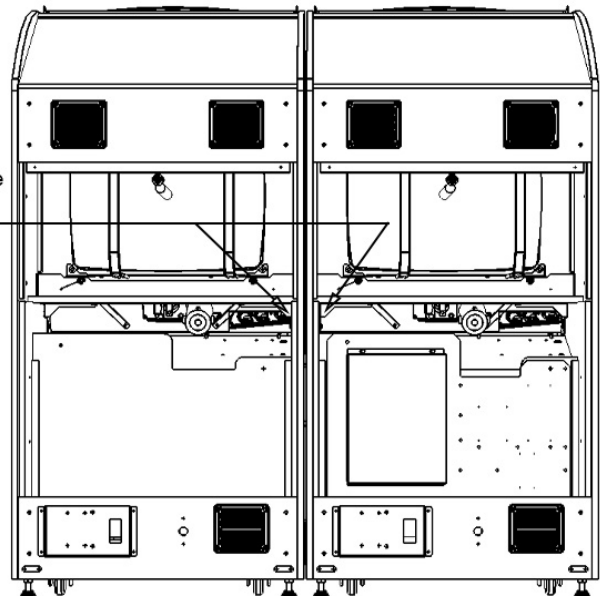

Step 7.  
Apply the 2x Join Brackets (FR-0013UK) to the outside of the cabinets as shown.  
Secure using the 8x M8x30 bolts (supplied).

Fit 2x Joint Bkts(supplied) in to the locations shown and secure using 8x M8x30 Hex bolts.

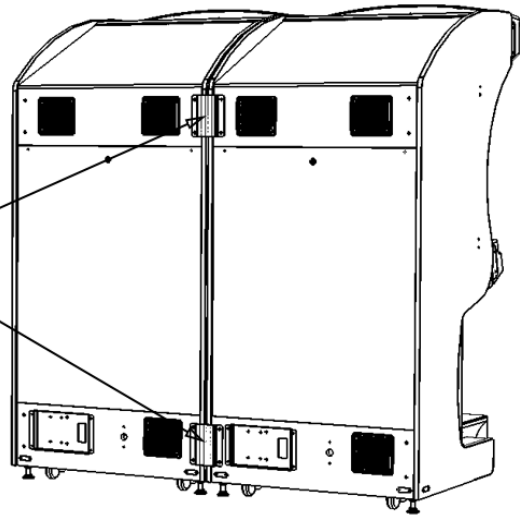

Step 8.  
The seat brackets are attached to the seat cabinet but will be inverted for transportation.  
Reposition the brackets so that they depict the figure to the right and secure with the same fixings.

Reposition the seat brackets as shown and secure.

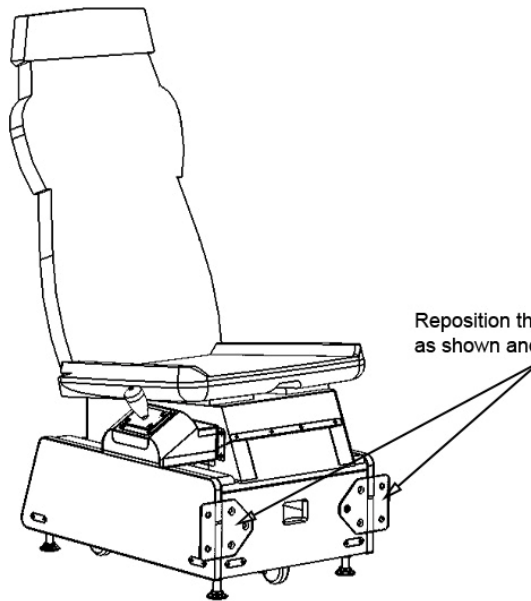

Step 9.  
Offer the seat cabinet up to the display cabinet. Before attaching both cabinets, make sure that the seat harness has been connected to the main harness. Once connection has been established, secure both seat cabinets to the main cabinets using 4x M8x30 Hex Bolts Black.

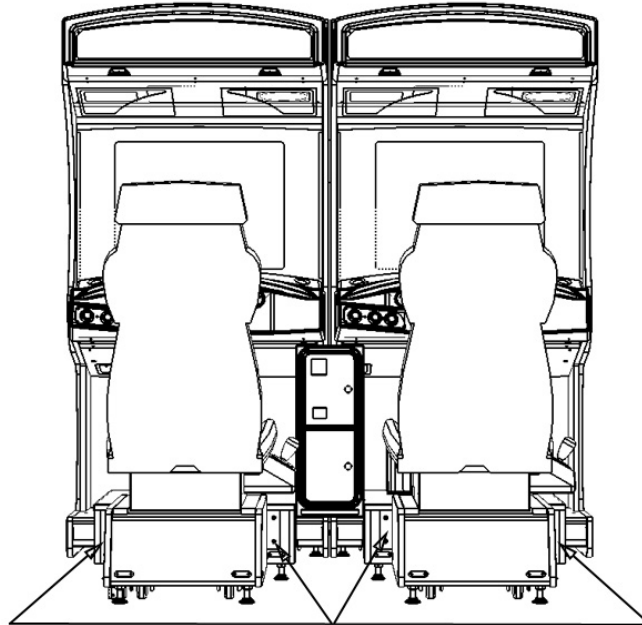

Fix the seat cabinets into position as shown and secure using 8x M8x30 hex bolts black. (13mm) (Make harness connections before securing.)

Step 10. Tighten ALL bolts in their present location using a 13mm hex driver.

## 2

## SECURING THE MACHINE INTO LOCATION



- Make sure that all of the adjusters are in contact with the floor. If they are not, the cabinet may move and cause an accident or injury.
- Be sure to use two people to perform this work. Depending on the specific work, there are some cases in which working by one person alone may cause an accident or injury.

The machine has 14 casters (7 per unit) and 16 leg adjusters (8 per unit). When the installation position is determined, bring the adjusters in contact with the floor. Make the adjustment so that the casters rise from the floor approximately 5mm. Also make sure that the machine positioning is level.

### Step 1.

Move the machine to the installation position. When installing the machine against or close to a wall, be sure to secure a space to ensure player can safely enter and exit the machine without obstruction.

### Step 2.

Bring all leg adjusters down to make contact with the floor. Using a Wrench or spanner adjust the leveller so that the casters rise approximately 5mm from the floor.

### Step 3.

Once all adjusters have been adjusted and the machine is made level, fasten the adjuster nut upwards to secure the height of the adjuster.

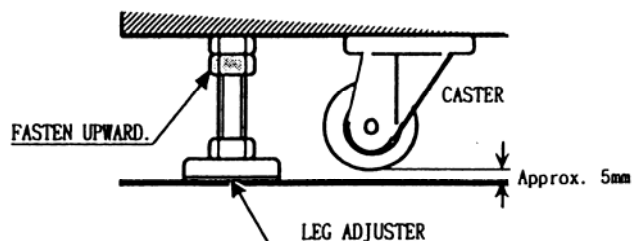
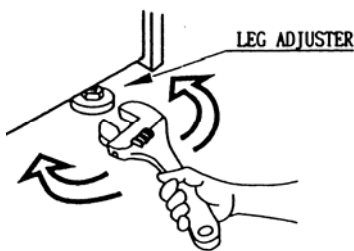
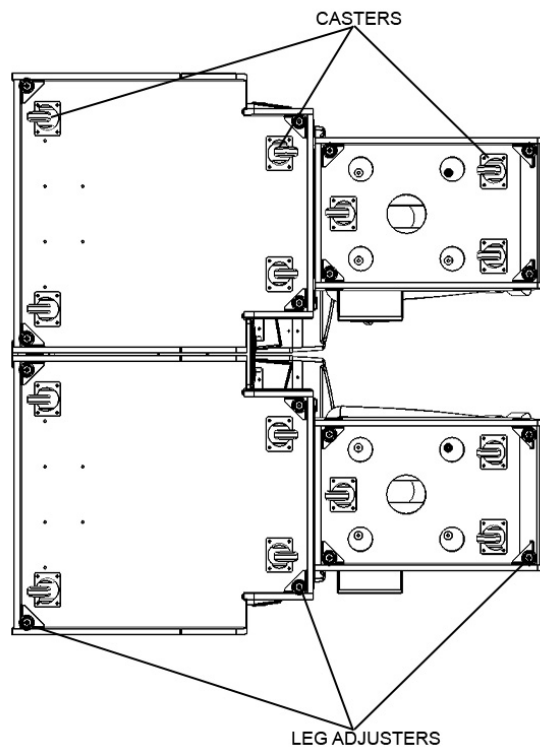

After securing the height of the adjusters, tighten all of the hexagon bolts which were fastened temporarily as per step 1.

### 3

## INSTALLING THE POP PANEL.



- To perform work safely and securely, be sure to use a step which is in a secure and stable condition. Performing work without a step or a step which is not in a suitable condition may cause an accident or injury.

Remove the 2x machine screws from the front of the Pop Panel Bracket.

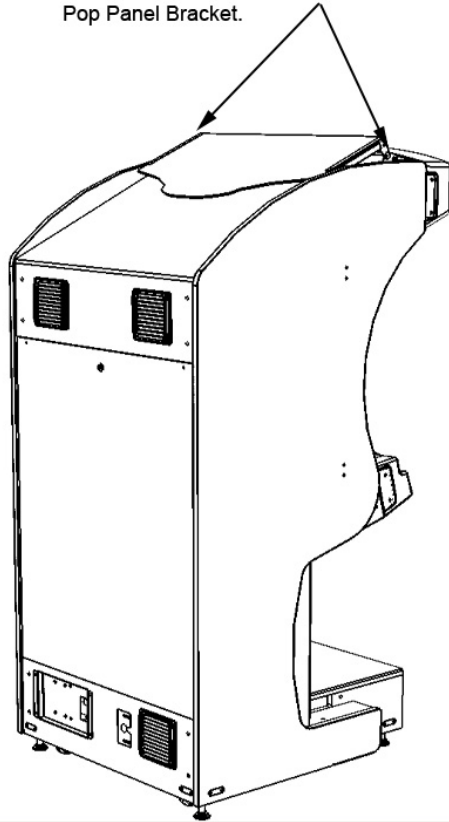

Step 1.



Step 2

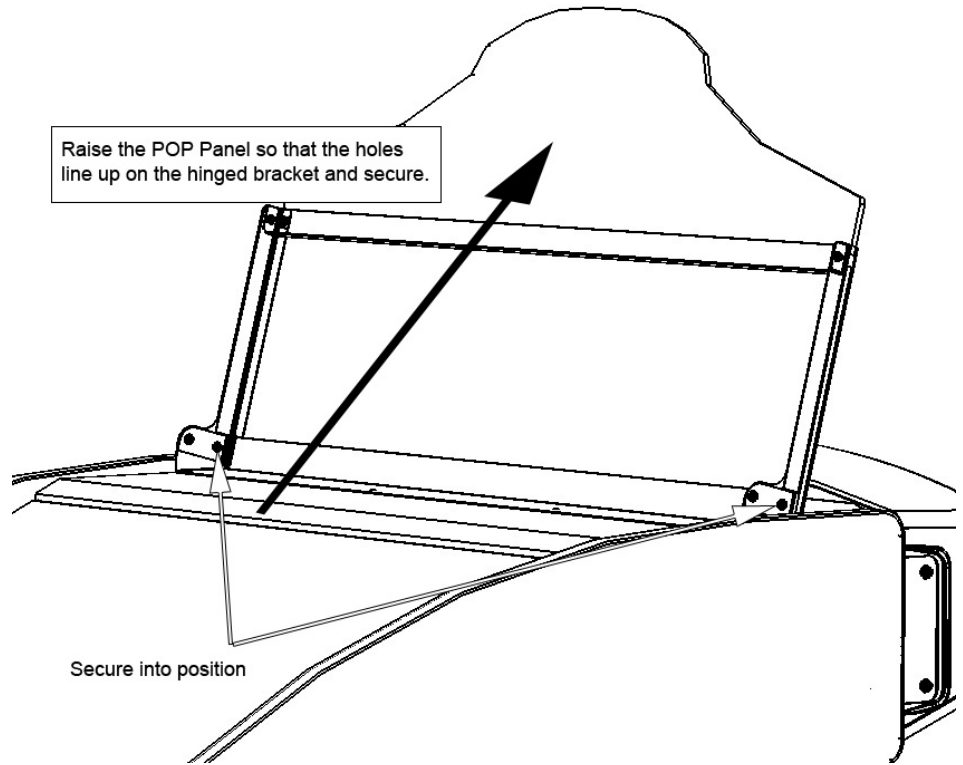

## 4

## INSTALLING THE POWER CABLES



- Be sure to use an independent power supply socket equipped with an Earth Leakage Breaker. Using a power supply without an Earth Leakage Breaker can lead to a fire or potential shock hazard.
- **THIS PRODUCT MUST BE EARTHED.**
- Ensure that the power cord is not exposed on the surface. If exposed the cord may be susceptible to damage. If damaged, the cord may cause electric shock or fire hazard. Ensure that the power cord is not in the customers walk way or that the cord has a protective cover.

The AC unit is mounted on the 1P COCKPIT. The AC unit incorporates the Main SW, Fuse, Primary Earth Terminal and the AC Inlet socket.

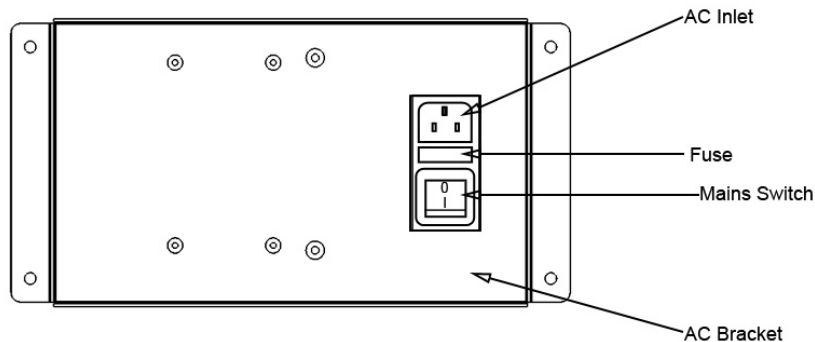

Firmly insert the 3 pin power plug (UK) or 2 pin power plug (EU) into the socket outlet. Insert the opposite end of the power cord into the AC inlet of the AC bracket.

Install suitable protective wire covering for the power cord to prevent any accidents or injury (not supplied).

## 5

## TURNING THE POWER ON

Turning the AC UNIT main switch on will cause the machine to start the POWER ON check and NETWORK check automatically.

In the power on check the steering wheel may turn. DO NOT interrupt the steering wheel as it moves as it may cause steering problems during the game.

During network checking "PLEASE WAIT" flashes on screen. When the network checking has finished, the game demo mode will start. If after initialization connection has not been established, check the network connections between cabinets and repeat process.

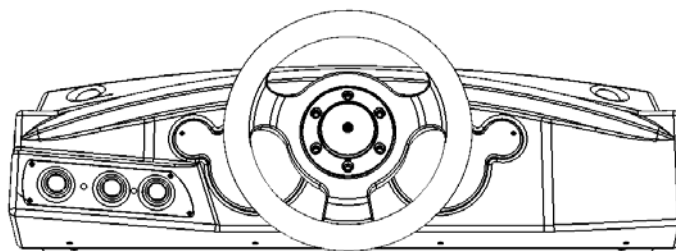

# 6

## ASSEMBLY CHECK

In the TEST MODE, ensure that the assembly has been made correctly and the IC BD is satisfactory. In the TEST MODE, perform the following tests.

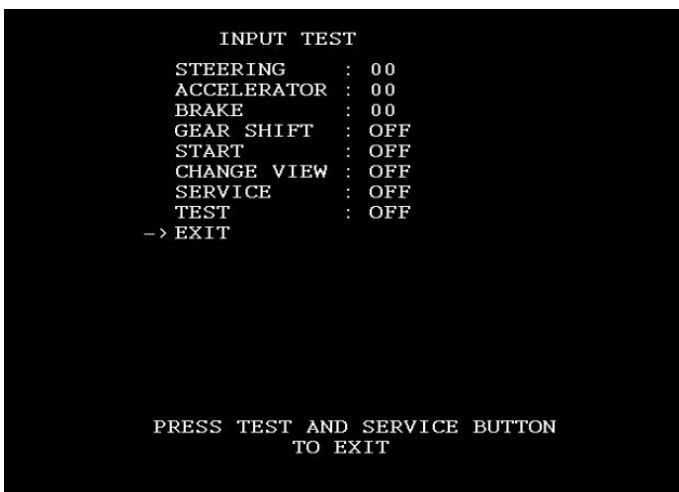

Select the INPUT TEST from the SYSTEM MENU (left screen). This screen enables the user to test individual input to the game. Once all input devices have been tested and proved to be in working order, press the test and service buttons to exit.

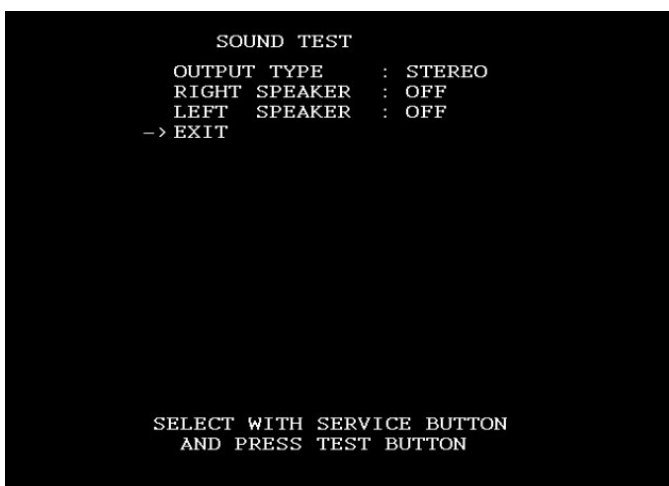

In the SOUND TEST, use the service switch to access left and right speaker outputs. Check that both speakers are working satisfactory and that the sound levels are set to an appropriate level.

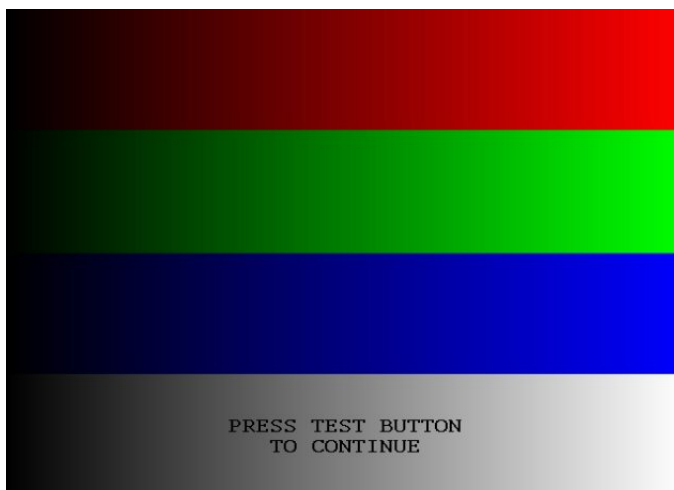

In the SYSTEM TEST MODE MENU select the CRT TEST. Although the monitor adjustments have been made before shipping, make sure that the image covers the screen without loss of graphics. If necessary, adjust the monitor. Use the DEGAUSE switch if necessary to bring the colours back into perspective.

## 8. PRECAUTIONS TO BE TAKEN WHEN MOVING THE MACHINE



- When moving the machine, be sure to unplug the power cord from both the wall and machine ends. Moving the machine whilst either plug is inserted can cause either an accident or injury by electric shock.
- When moving the machine along the floor, retract the Adjusters and ensure that the casters make contact with the floor. During transportation, pay careful attention so that the castors do not manoeuvre over power cables. Damaging power cables can cause electric shock or a short circuit hazard.
- When moving the machine, do not push the cabinets with the seat fixed. Moving the cabinets whilst the seat are fixed may cause damage to the fixing positions of the seat.



- When transporting the product in places where steps are used to gain access, disassemble the seat units from the main cabinets as damage can occur at the adjoining positions.

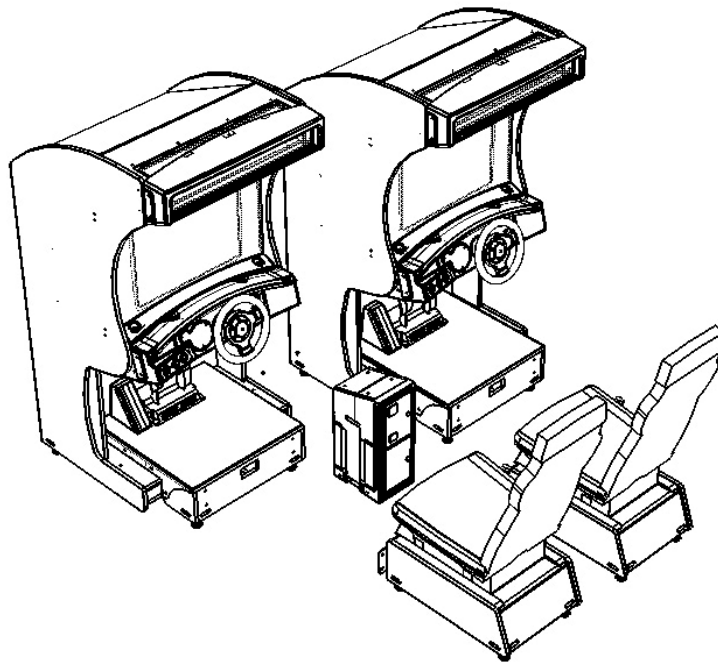

When transporting the machine in places where steps have to be contended with, break the machine down into individual parts to make transit easier.

## 9. BASIC CONTENTS OF THE GAME

The following outlines basic routines to check whether the product is functioning satisfactory. If there is a deviation between what is explained in this section and the actual results of the machine then immediately look into the cause of fault and eliminate the cause to ensure satisfactory operation.

During the attract mode, the START button will flash, the BILLBOARD lamps will be lit and audio will be emitted from both left and right speakers. (There are no speakers in the seat assembly).

1. Sit in the Cockpit. The seat can be adjusted in either a forward or reverse positions. The lever is located on the lower right hand side in front of the seat. Pull this lever to make adjustments to the seat.
2. Insert a coin(s). The number of credit(s) is displayed in the bottom left hand side of the screen.
3. Press the green "CREDIT" button and the credit will transfer from the VTS BD to the cabinet which is calling for credit. A visual indication of credits displayed at the bottom left corner of the screen will increment by the amount of credits set. "PRESS START" will appear on screen.
4. Press the "START" button and the game will start by employing the driver to select certain criteria's i.e. type of car, type of course.

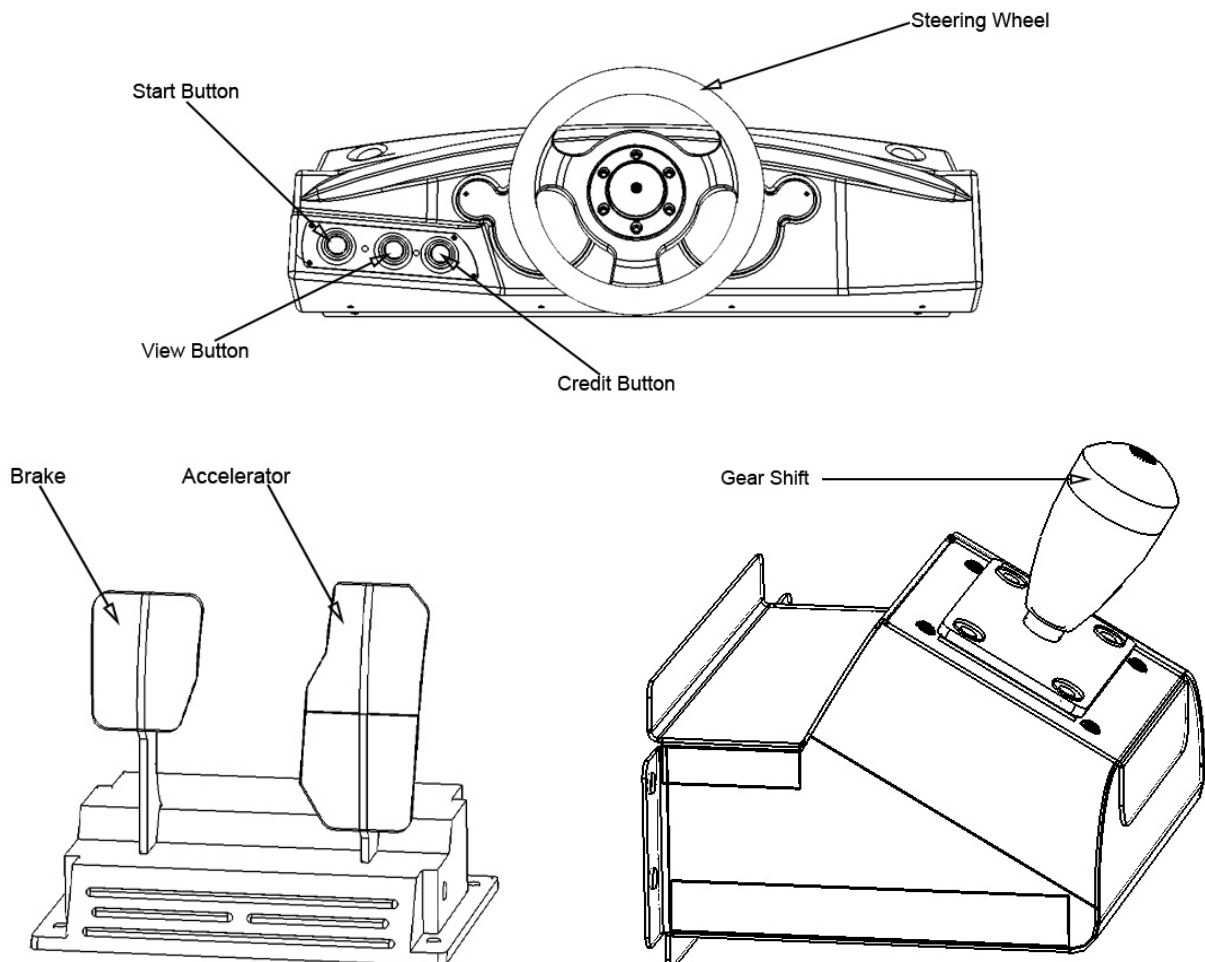

## 10. EXPLANATION OF TEST AND DATA DISPLAY

By operating the buttons located on the VTS BD will enable the SYSTEM and GAME TEST MODES. When installing the machines, collecting cash or when the machine does not perform correctly, initiate a test sequence as explained in this section of the manual. The following outlines each test mode and explains in detail the movement throughout the menus.



- ONLY A QUALIFIED SERVICE ENGINEER SHOULD MAKE ANY AMMENDMENTS TO THE CRITERIAS LISTED WITHIN THE SYSTEM TEST MENU.

ITEMS	DESCRIPTION
MACHINE INSTALLATION	<p>When the machine is installed, perform the following:</p> <ol style="list-style-type: none"> <li>1. Check that each setting is set to the factory setting as per the time of shipment.</li> <li>2. In the INPUT TEST mode, check each switch and VR for operation.</li> <li>3. In the SOUND TEST check the operation of both front speakers.</li> <li>4. In the CRT TEST check the adjustment of the picture and adjust if necessary.</li> </ol>
PERIODIC SERVICING	<p>Periodically perform the following tests:</p> <ol style="list-style-type: none"> <li>1. In the INPUT TEST mode, check the CONTROL devices and buttons.</li> <li>2. In the SOUND TEST perform a sound check.</li> </ol>
MONITOR	<p>In the monitor check screen, check to see if the MONITOR adjustments are made correctly.</p>
DATA CHECK	<p>Check such data as game play time and histogram and adjust difficulty levels if necessary.</p>

## 10.1. VTS BOARD – SWITCHES AND COIN COUNTER



- Never touch places other than those specified. Touching parts in places not specified may cause electric shock or a short circuit hazard.



- Adjust to the optimum sound volume taking in consideration the environmental requirements of the installation location.

### VTS BOARD

Open the top coin tower door and the VTS BOARD is located on the back panel. The function of each control is as follows:

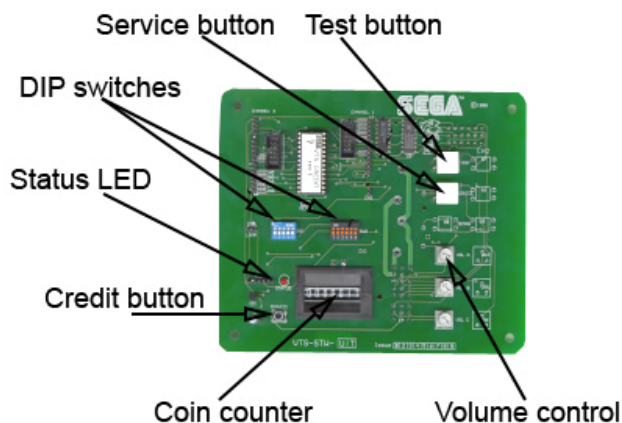

- TEST BUTTON:** Enables the SERVICE ENGINEER to enter the TEST MODE. Please refer to the following pages.
- SERVICE BUTTON:** Gives service credits without registering on the coin counter.
- DIP SWITCHES:** Configures the price of play.
- STATUS LED:** Flashes in normal operation.
- CREDIT BUTTON:** As the SERVICE BUTTON.
- COIN COUNTER:** Registers the count of coins inserted through the coin mechanism in 10p or 10 cent units.
- VOLUME CONTROL:** Adjusts the level of sound emitted from the front speakers.

## 10.2. TEST MODE



- When changes are made in the TEST MODES, be sure to EXIT from the TEST MODES to return to GAME MODE. If power is turned OFF in TEST MODE, the new setting will not take effect.

The Test Menu allows the functioning of each part of the cabinet to be checked, the monitor to be adjusted and the coins and various related game setting to be changed.

- Press the test button to enable the TEST MODE to be displayed on screen.
- Press the SERVICE BUTTON to move the pointer on-screen to the desired function.
- Once the desired function has been established, press the TEST BUTTON to enter that particular test.

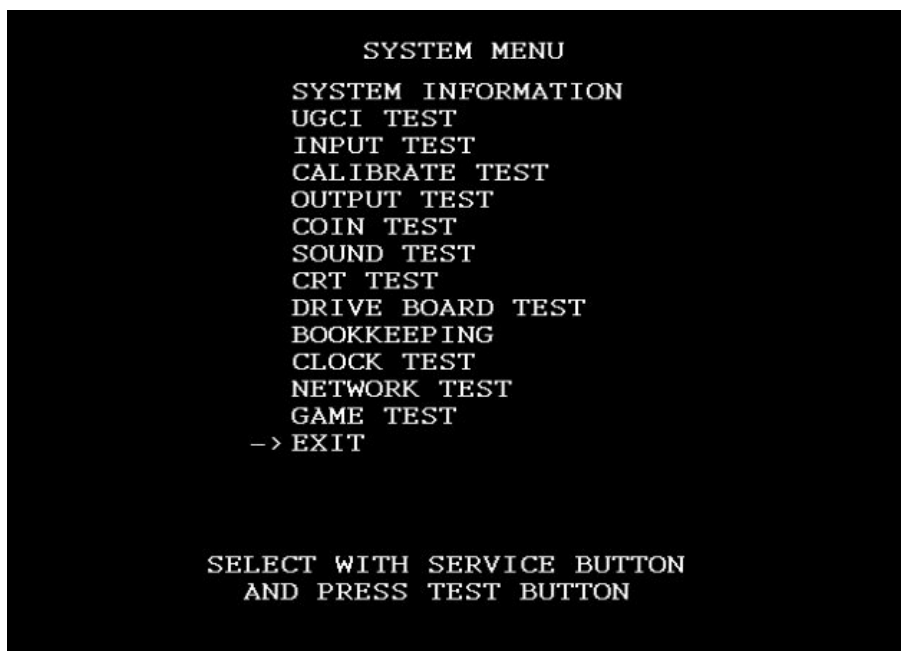

SYSTEM INFORMATION	Displays general information on installed software and hardware.
UGCI TEST	Displays test routines for UGCI communications.
INPUT TEST	Displays test routines for input devices.
CALIBRATE TEST	Displays calibration test for input devices.
OUTPUT TEST	Displays test routines for output devices.
COIN TEST	Displays test routine for coin handling devices.
SOUND TEST	Displays test routine for audio outputs.
CRT TEST	Displays test routine for visual adjustment.
DRIVE BOARD TEST	Displays test routines for steering force feedback system.
BOOKKEEPING	Displays pages of various game information.
CLOCK SETTING	Displays the setting for the internal clock.
NETWORK TEST	Displays test routine for communications.
GAME TEST	Displays menus for specific game test routines.
EXIT	Leaves System Test and returns to game mode.

The operator uses the SERVICE button to select the desired test routines and presses the TEST button to activate choice.



### 10.3. SYSTEM INFORMATION

This test displays general system information regarding the hardware configuration and installed software.

```
                SYSTEM INFORMATION
SYSTEM ID      : 12345678
DISK IMAGE    : Alpha
LAUNCHER      : 0.2.16
GAME SHELL    : 0.2.16
GAME NAME     : FORDRACING
GAME VER      : 1.0
UGCI VER      : 5.2
IBUTTON       : FORDRACING
-> EXIT

                PRESS TEST BUTTON TO EXIT
```

SYSTEM ID	A unique 64 bit ID code to identify the system
DISK IMAGE	Version number for master disk image
LAUNCHER VERSION	Version number for System Launcher
GAME SHELL VERSION	Version number for Game Shell
GAME NAME	Name of the installed game
GAME VERSION	Version number of installed game
UGCI VERSION	Hardware version of installed UGCI board
IBUTTON	Type of iButton installed (Game Name or SYSTEM). If no iButton is installed, then a NOT FOUND message is shown
EXIT	Return to SYSTEM MENU

The user cannot modify any of the parameters in this test. The user must press the TEST button to exit this test.

## 10.4. UGCI TEST

This test is used to test the network link between the computer and the UGCI board.

```
UGCI TEST
COIN COUNT 1 : 0A
COIN COUNT 2 : 00
VERSION      : UNKNOWN
UGCI STATUS  : NOT CONNECTED

-> EXIT

PRESS TEST BUTTON TO EXIT
```

COIN 1 COUNT	Value of UGCI NVR coin count 1
COIN 2 COUNT	Value of UGCI NVR coin count 2
VERSION	Version number of UGCI board
UGCI STATUS	OK is the system can communicate with the UGCI board, otherwise a NOT CONNECTED message is shown.
EXIT	Return to SYSTEM MENU

The user cannot modify any of the parameters in this test. The user must press the TEST button to exit this test.

## 10.5. INPUT TEST

This test is used to test and calibrate the peripherals connected to the UGCI interface.

```
                INPUT TEST
                STEERING      : 00
                ACCELERATOR   : 00
                BRAKE         : 00
                GEAR SHIFT    : OFF
                START         : OFF
                CHANGE VIEW   : OFF
                SERVICE       : OFF
                TEST          : OFF
                -> EXIT

                PRESS TEST AND SERVICE BUTTON
                TO EXIT
```

STEERING	00H = Full Left lock, 80H = Centre, FFH = Full right lock
ACCELERATOR	00H = pedal fully up, FFH = pedal fully down
BRAKE	00H = pedal fully up, FFH = pedal fully down
GEAR SHIFT	UP = stick up, N = stick central, DOWN = stick down
START	On = pressed, OFF = not pressed
CHANGE VIEW	On = pressed, OFF = not pressed
SERVICE	On = pressed, OFF = not pressed
TEST	On = pressed, OFF = not pressed
EXIT	Exit to System Menu

Please refer to the CALIBRATION TEST for calibrating the hand and foot controllers.

As this test will check for functionality of both the TEST and SERVICE buttons, in order to exit this test, BOTH buttons must be pressed simultaneously.

## 10.6. CALIBRATION TEST

This test is used to calibrate the analogue system input devices, i.e. the steering wheel, throttle pedal and brake pedal.

```
CALIBRATE TEST
STEERING LEFT VAL : 00
STEERING RIGHT VAL : FF
BRAKE DOWN VAL : FF
BRAKE UP VAL : 00
THROTTLE DOWN VAL : FF
THROTTLE UP VAL : 00
CALIBRATE STEERING
CALIBRATE BRAKE
CALIBRATE THROTTLE
-> EXIT

SELECT WITH SERVICE BUTTON
AND PRESS TEST BUTTON
```

STEERING LEFT VAL	The current maximum left position of the steering wheel
STEERING RIGHT VAL	The current maximum right position of the steering wheel
BRAKE DOWN VAL	The current maximum down position of the brake pedal
BRAKE UP VAL	The current maximum up position of the brake pedal
THROTTLE DOWN VAL	The current maximum down position of the throttle pedal
THROTTLE UP VAL	The current maximum up position of the throttle pedal
CALIBRATE STEERING	Starts the steering calibration routine. The user must follow the on screen prompts to turn the wheel full left and then full right for 5 seconds.
CALIBRATE BRAKE	Starts the brake calibration routine. The user must follow the on screen prompts to fully depress and then release the brake pedal for 5 seconds.
CALIBRATE THROTTLE	Starts the throttle calibration routine. The user must follow the on screen prompts to fully depress and then release the throttle pedal for 5 seconds.
EXIT	Exit to System Menu

The user will use the SERVICE button to select the desired test and the TEST button to activate the test.

## 10.7. OUTPUT TEST

This test is used to test any output signals (i.e. lamps) from the system.

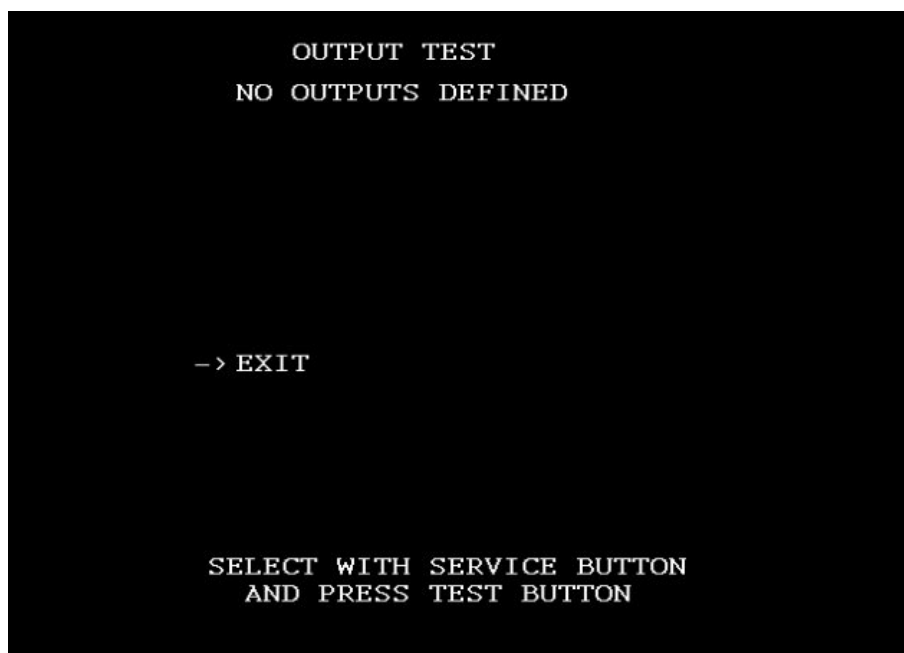

EXIT

Exit to System Menu

There are currently no output tests defined. Use the TEST button to return to the System Menu.

## 10.8. COIN TEST

This test is used to set coin related parameters.:

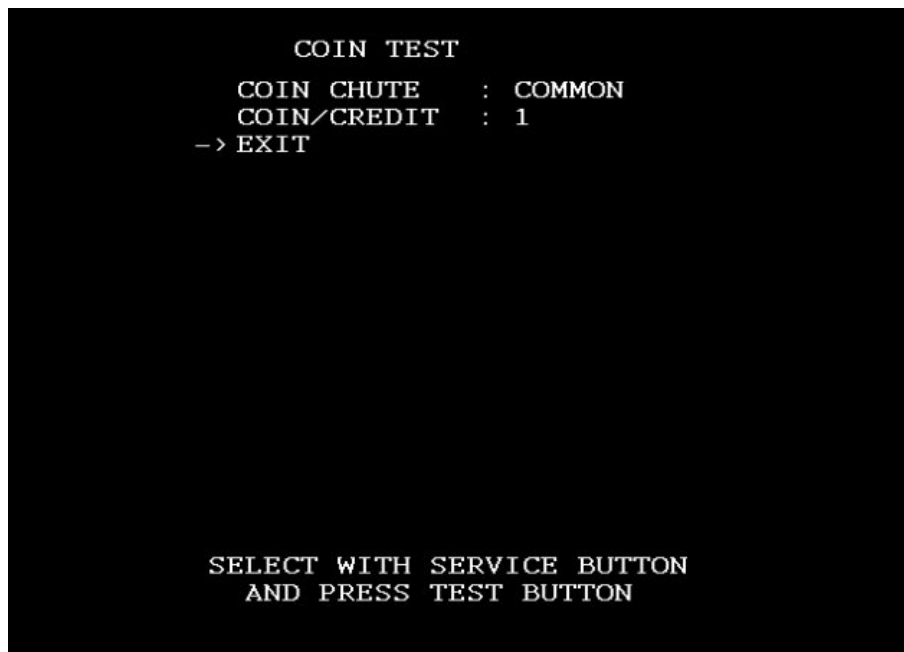

COIN CHUTE	This option is fixed to COMMON
COIN/CREDIT	This is used to select how many credits per play are required. There are currently two options : 1 indicates 1 credit per play, and FREEPLAY indicates that no credits are required for play. Note that the actual value of coins required for 1 credit is defined by the VTS board settings.
EXIT	Exit to System Menu

The user can select the LEFT and RIGHT speaker status to ON or OFF to test that speaker channel. Use the TEST button to return to the System Menu.

## 10.9. SOUND TEST

This test is used to test the audio system is working correctly :

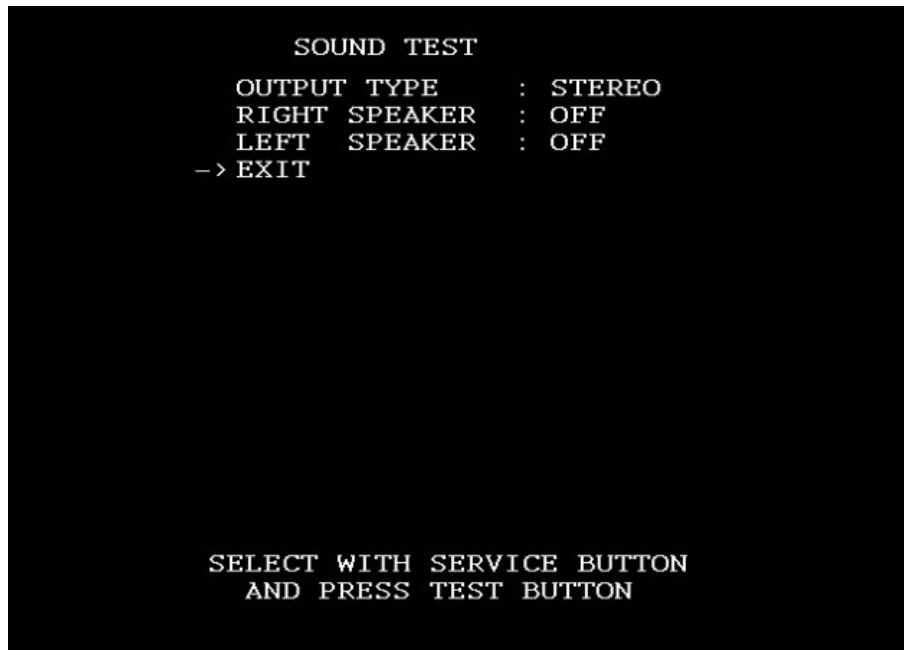

OUTPUT TYPE	This option is fixed to STEREO
RIGHT SPEAKER	When ON, a sound will be played from the RIGHT speaker
LEFT SPEAKER	When ON, a sound will be played from the LEFT speaker
EXIT	Exit to System Menu

The user can select the LEFT and RIGHT speaker status to ON or OFF to test that speaker channel. Use the TEST button to return to the System Menu.

## 10.10. CRT TEST

This test is used to test the game display is working correctly. It consists of two screens :

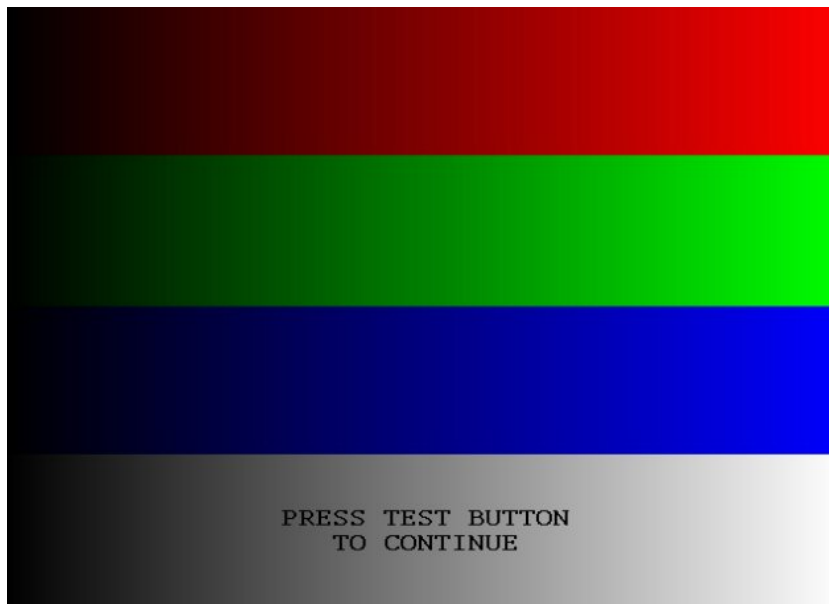

COLOUR TEST



GRID TEST

Press the TEST button to move from COLOUR TEST to GRID TEST. Press the TEST button again to return to the System Menu.



## 10.11. DRIVE BOARD TEST

This test is used to test the steering force feedback mechanism.

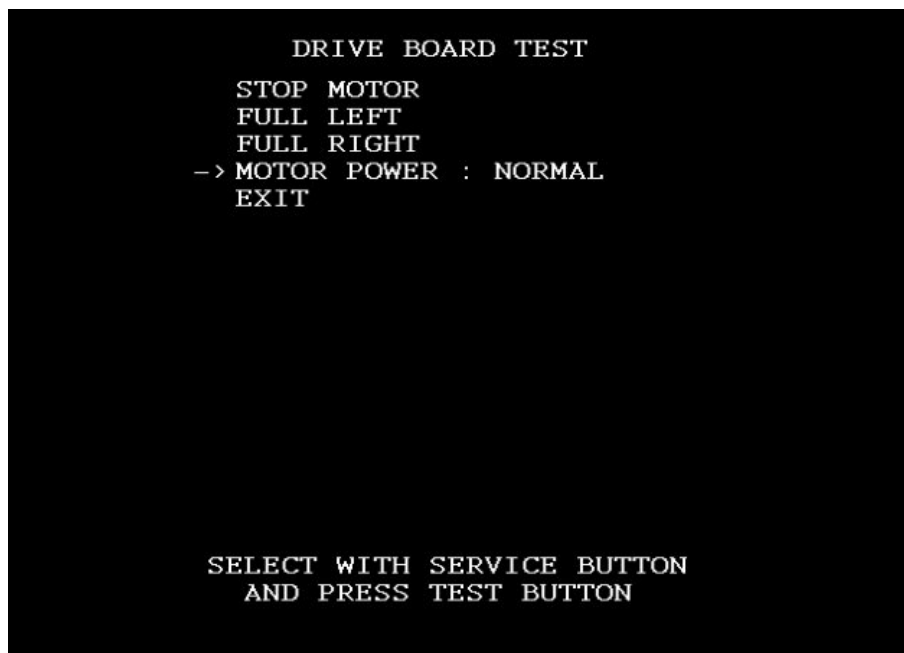

STOP MOTOR	Turn off all drive signals to the force feedback motor
FULL LEFT	Apply a maximum left signal to the force feedback motor (subject to power setting)
FULL RIGHT	Apply a maximum right signal to the force feedback motor (subject to power setting)
MOTOR POWER	This has four settings : NORMAL : A normal torque setting STRONG : A strong torque setting (recommended for adult only environments) WEAK : A very weak torque setting (recommended for child only environments) NONE : No force feedback torque is applied.
EXIT	Exit to System Menu

Once the user has selected the required motor power, he can test the setting by using the FULL LEFT or FULL RIGHT test. All motor power will be removed when the user exits from the test.

## 10.12. BOOKKEEPING

This test is used to review statistical data from the system. It consists of 3 main screens of data. Screen 1 contains an overview of game play data.

```
BOOKKEEPING 1/3
1PLYR GAMES PLAYED: 6
MPLYR GAMES PLAYED: 0
COIN CREDITS      : 1
SERVICE CREDITS  : 6
TOTAL TIME ON    : 0000:35:00
TOTAL 1PLYR TIME : 0000:13:30
TOTAL MPLYR TIME : 0000:00:00
AVERGE 1PLYR TIME : 02:15
AVERGE MPLYR TIME : 00:00
CLEAR HISCORES
CLEAR BOOKKEEPING
-> NEXT SCREEN

SELECT WITH SERVICE BUTTON
AND PRESS TEST BUTTON
```

1PLYR GAMES PLAYED	The total number of 1 player games played
MPLYR GAMES PLAYED	The total number of multi player games played
COIN CREDITS	The total number of coin credits entered
SERVICE CREDITS	The total number of service credits entered
TOTAL TIME ON	The total time the cabinet has been switched on, in HHHH:MM:SS
TOTAL 1PLYR TIME	The total time of all 1 player games played, in HHHH:MM:SS
TOTAL MPLYR TIME	The total time of all multiplayer games played, in HHHH:MM:SS
AVERAGE 1PLYR TIME	The average game time for a 1 player game
AVERAGE MPLYR TIME	The average game time for a multiplayer game
CLEAR HISCORES	When selected, the user will be prompted to confirm, YES or NO. If the user selects YES, the high-score table is reset to factory default. If NO is selected, then no action is taken.
CLEAR BOOKKEEPING	When selected, the user will be prompted to confirm, YES or NO. If the user selects YES, all bookkeeping meters will be cleared to zero. If NO is selected, then no action is taken.

**\*\* Please note: ALL linked cabinets MUST be in TEST MODE when this is carried out. Otherwise existing HIGH SCORES from linked cabinet will be copied from machine to machine. \*\***

NEXT SCREEN                      Proceed to bookkeeping screen #2

Bookkeeping Screen 2 contains a breakdown of game plays on a day to day basis.

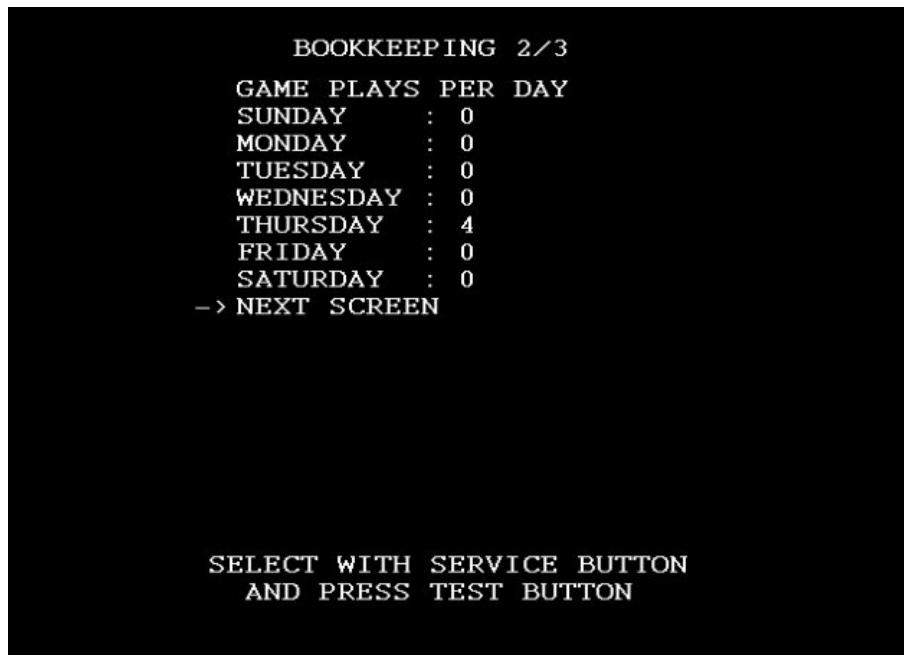

SUNDAY	The total number of games played on a Sunday
MONDAY	The total number of games played on a Monday
TUESDAY	The total number of games played on a Tuesday
WEDNESDAY	The total number of games played on a Wednesday
THURSDAY	The total number of games played on a Thursday
FRIDAY	The total number of games played on a Friday
SATURDAY	The total number of games played on a Saturday
NEXT SCREEN	Proceed to bookkeeping screen #3

Bookkeeping Screen 3 contains a breakdown of game plays on a day to day basis.

```
BOOKKEEPING 3/3
GAME PLAYS PER HOUR
00-01 : 0      12-13 : 0
01-02 : 0      13-14 : 0
02-03 : 0      14-15 : 0
03-04 : 0      15-16 : 2
04-05 : 0      16-17 : 2
05-06 : 0      17-18 : 0
06-07 : 0      18-19 : 0
07-08 : 0      19-20 : 0
08-09 : 0      20-21 : 0
09-10 : 0      21-22 : 0
10-11 : 0      22-23 : 0
11-12 : 0      23-00 : 0
-> EXIT

SELECT WITH SERVICE BUTTON
AND PRESS TEST BUTTON
```

00 - 01	The total number of games played between midnight and 1am
01 - 02	The total number of games played between 1am and 2am
23 - 00	The total number of games played between 11pm and midnight
EXIT	To return to the SYSTEM TEST MENU SCREEN.

## 10.13. CLOCK SETTINGS

This test is used to set the current time and date of the computer system.



- Date cannot be changed until the AUTO UPDATE has been released. Once the AUTO UPDATE has been release and installed only then can the date be change.

```
CLOCK SETTING
CURRENT TIME   : 09:24:25
CURRENT DATE   : 09/03/2006

YEAR
MONTH
DAY
HOURS
MINUTES
SECONDS
-> EXIT

CLOCK ADJUSTMENT DISABLED
UNTIL 26/03/2006

SELECT WITH SERVICE BUTTON
AND PRESS TEST BUTTON
```

YEAR	Variable from 2000 to 2050
MONTH	Variable from 01 to 12
DATE	Variable from 1 to 28, 29, 30 or 31 (dependant on MONTH & YEAR)
HOURS	Variable from 0 to 23
MINUTES	Variable from 0 to 59
SECONDS	Variable from 0 to 59
EXIT	Exit to System Menu after adjusting clock to new value

## 10.14. NETWORK TEST

This test is used to test the network link between two computers in a twin cabinet.

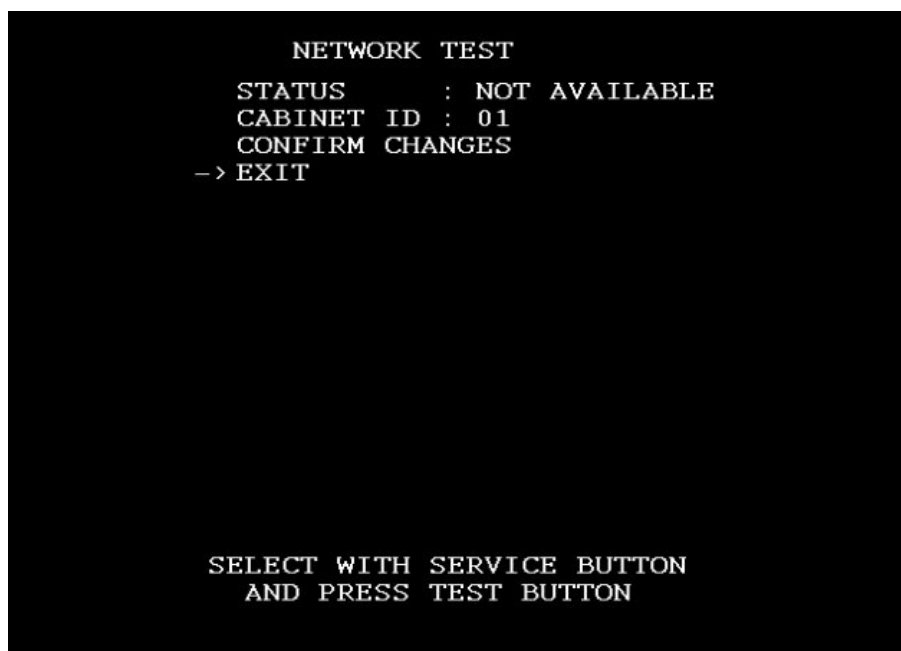

STATUS	OK if Ethernet link is operating, NOT AVAILABLE otherwise
CABINET ID	ID of this cabinet, variable from 1 to 6. No linked cabinets should have the same ID. Once changed, the user must select CONFIRM CHANGES to complete the setting.
CONFIRM CHANGES	The user will be prompted to confirm YES or NO. If YES is selected, the system will perform a system reboot. If NO is selected, no action will be action.
EXIT	Exit to System Menu

In order for the network status to display OK, BOTH sides of the cabinet must be set to network test. When selected, the test will send data packets between the two systems to validate the link. If the link is valid, the display will be shown OK. If the link is disconnected or otherwise not functioning, the display will show NOT AVAILABLE.

## 10.15. GAME TEST MODE



- All default setting shown in **BOLD**.

```
GAME TEST
UPGRADES : ON
Language : english
DifficultyLevel : medium
SoundEffectsVolume : high
SpeechVolume : high
AmbientVolume : high
IngameMusicVolume : high
MenuMusicVolume : high
AttractModeVolume : high
-> EXIT

SELECT WITH SERVICE BUTTON
AND PRESS TEST BUTTON
```

UPGRADES	UPGRADES <b>ON</b> – is displayed only after the official upgrafe drop. The official upgrade drop for this edition will be 01/11/06.
LANGUAGE	Choose the language setting for the installed region. Choice is: <b>English</b> , Spanish, German, Italian and French.
DIFFICULTY LEVEL	Choose between: EASY, <b>MEDIUM</b> and HARD.
SOUND EFFECT VOLUME	Indicates the set volume level of the sound effects i.e. skidding, crashing. LOW, MEDIUM and <b>HIGH</b> .
SPEECH VOLUME	Indicates the volume level of speech. LOW, MEDIUM and <b>HIGH</b> .
AMBIENT VOLUME	Indicates the level of ambient sounds i.e. Birds tweeting. LOW, MEDIUM and <b>HIGH</b> .
IN GAME MUSIC VOLUME	Indicates the level of game music. LOW, MEDIUM and <b>HIGH</b> .
MENU MUSIC VOLUME	Indicates the level of music when selecting through the option menus. LOW, MEDIUM and <b>HIGH</b> .
ATTRACT MODE VOLUME	Indicates the level of music during the attract or advertising mode. LOW, MEDIUM and <b>HIGH</b> .

Select EXIT with the SERVICE button and press the TEST button to EXIT.

## 11. HOW TO PLAY

### BASIC CONTROLS

Insert coin and press credit transfer button to move credit to desired seat position. Press Start button to begin a game. Choose your car category, car, transmission and track. View choices with the steering wheel and enter your selection with the gas pedal.

During game play use the gas pedal to accelerate your car and the brake pedal to stop. In automatic transmission the brake pedal also cause the car to reverse if pressed when the car is stationary. In manual transmission use the gear shifter to shift up and down through the gears. The view change button cycles between three camera angles

### GAME OUTLINE

The player controls a Ford car and races against six other cars to achieve a lap time record before the time limit is up. There is a great selection of tracks and cars. The off-road tracks can only be selected when a player selects a vehicle from the off-road category.

The race consists of three laps and the time limit is extended after each lap. If the time limit runs out the game is over.

The game can be played alone against computer-controlled opponents or up to 3 twin cabinets can be linked for multiplayer games of up to 6 challengers

#### GAME FLOW FOR SINGLE PLAYER MODE

- Player inserts coin(s)
- Press the CREDIT button to transfer credits to the appropriate cabinet.
- Press the START button when credits are available.





- Menu screen offers single or multiplayer game options
  - Player uses steering wheel to move the selection to single player
  - Player presses the gas pedal to select single player



- The next option is to choose the vehicle class.
  - Player uses the steering wheel to move to the selection required
  - Player then presses the gas pedal to select to option.



- Menu screen offers 6 cars in three difficulty levels (Beginner, Intermediate & Advanced)
  - Player uses steering wheel to move the selection to desired choice
  - Player presses the gas pedal to select their chosen car



- Menu screen offers Automatic or Manual transmission
  - Player uses steering wheel to move the selection to desired choice
  - Player presses the gas pedal to select their chosen transmission



- Menu screen offers a selection of 6 tracks
  - Player uses steering wheel to move the selection to desired choice
  - Player presses the gas pedal to select their chosen category

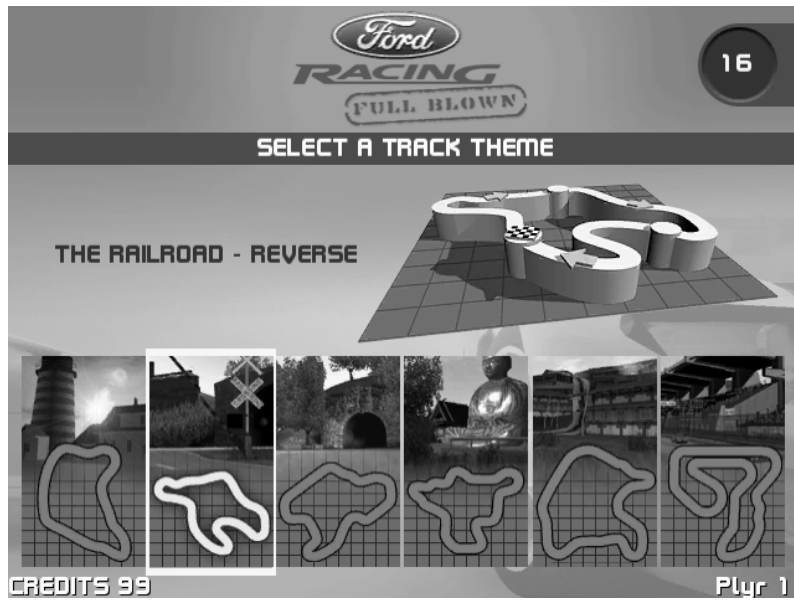

Race begins

The screen below shows a screenshot of a race in progress.



On screen displays are highlighted and labelled in the image blow.

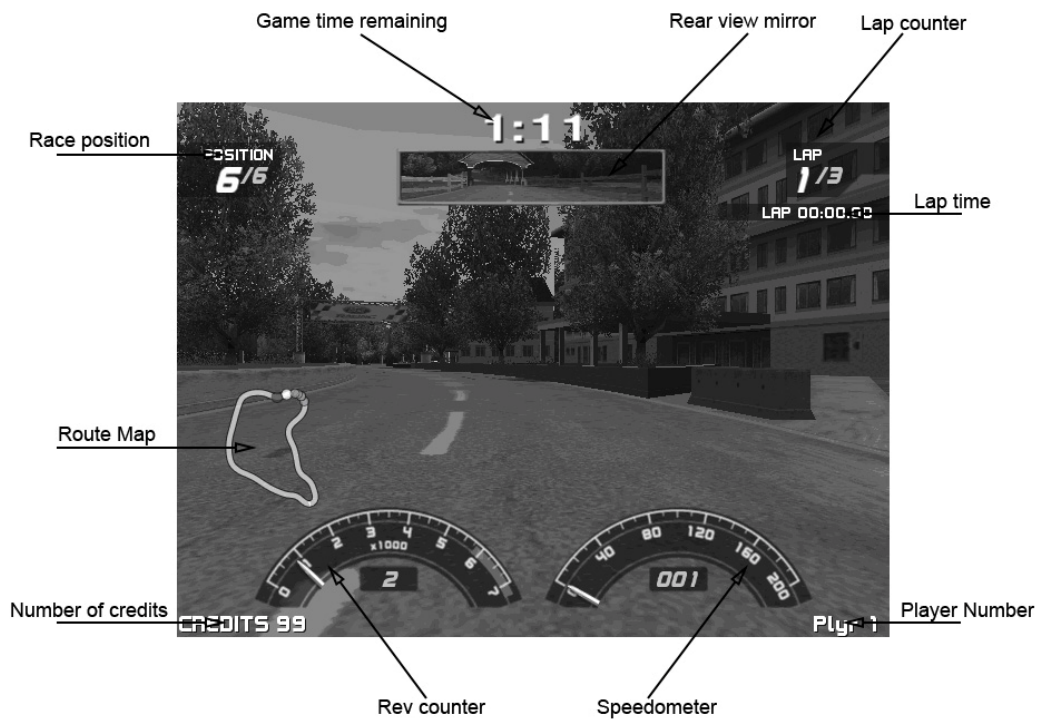

During the race the player can select from three different viewpoint by pressing the view button. These view points are: In Car, behind close and behind far. The rear view mirror is only available to the player in the "In Car" viewpoint.

The player must use their skill to finish the race in the time allotted to them. If their total race time is fast enough they are given the ability to enter three initials next to their score in the high score table.

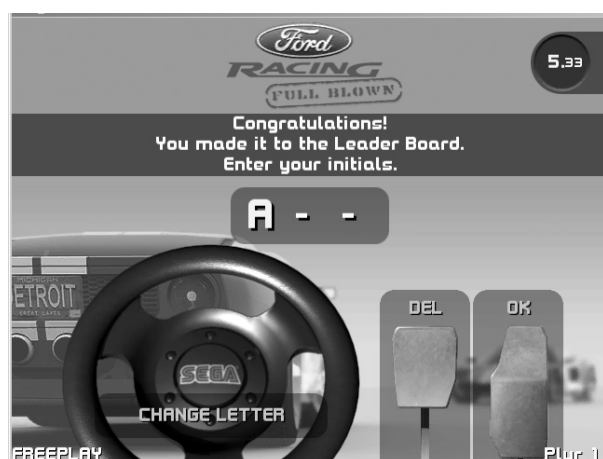

## GAME FLOW FOR MULTIPLAYER MODE

Game flow:

- Players inserts coin
- Credit button flashes to indicate that credit is available
- Players press the Credit button to transfer credit to their cabinet
- "Press Start" flashes on screen to notify the players
- The players presses the start button



- Menu screen offers single or multiplayer game options
  - Players use steering wheel to move the selection to multiplayer
  - Players press the gas pedal to select multiplayer



- Players wait for other players to join the game



- Menu screen offers car categories of classic, modern, performance and off-road
  - Players use steering wheel to move the selection to desired choice
  - Players press the gas pedal to select their chosen category

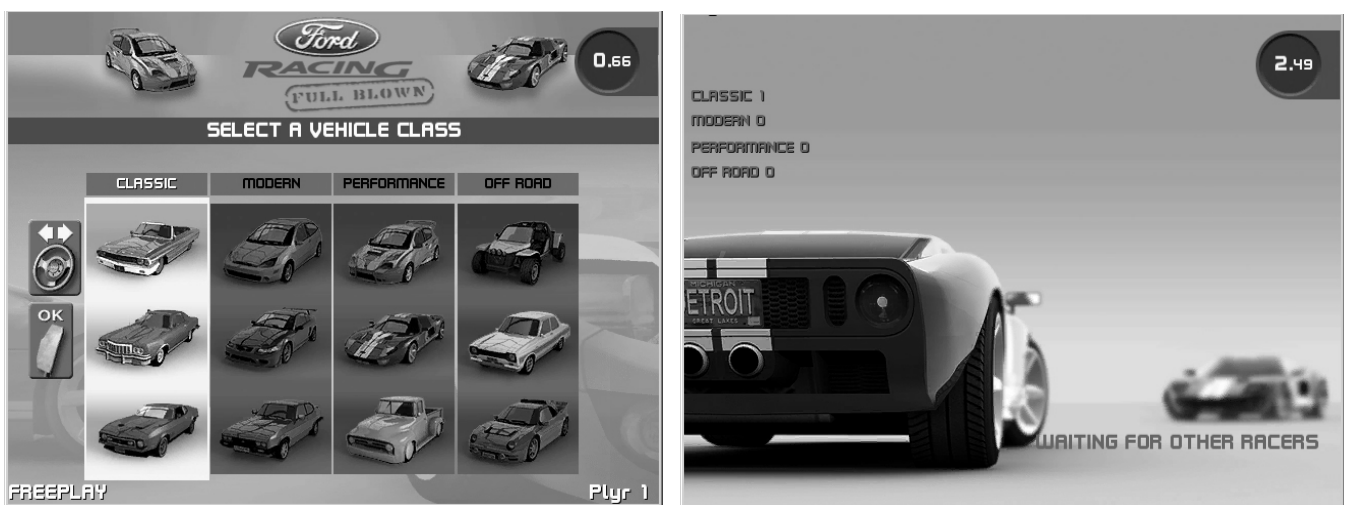

- If players select different categories then a voting system is employed so that the category chosen by the greatest number of players is used

- Menu screen offers 6 cars in three difficulty levels (Beginner, Intermediate & Advanced)
  - Player uses steering wheel to move the selection to desired choice
  - Player presses the gas pedal to select their chosen car



- Menu screen offers Automatic or Manual transmission
  - Player use steering wheel to move the selection to desired choice
  - Players press the gas pedal to select their chosen transmission



- Menu screen offers a selection of 6 tracks
  - Players use steering wheel to move the selection to desired choice
  - Players press the gas pedal to select their chosen category
  - If players select different tracks then a voting system is employed so that the category chosen by the greatest number of players is used

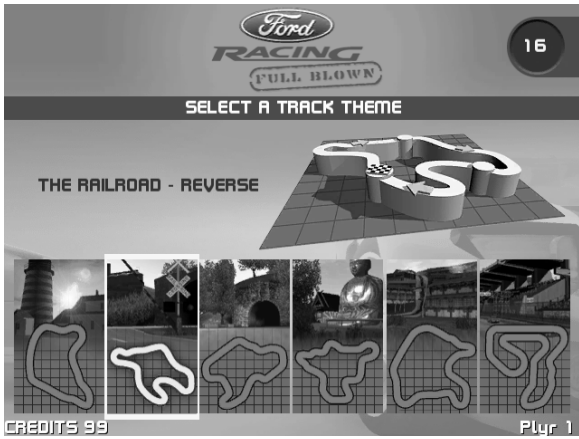

- Race begins



## TECHNIQUES AND SECRETS

### Super Start

If a player keeps the Revs of their car between 5,000 and 6,000 when the race begins they are given a speed boost.

### Hidden Shortcuts

Some of the tracks have hidden shortcuts that can help reduce lap times.

## CARS

The table below details all the cars available. Please note that only the cars for your given region (US or European) will be available. The Update column details the cars that will be swapped out with the vehicles marked with a \* on the preset update day.

### Classic

Start up		Update	
Europe		US	
1	1970 Mk1 Capri RS2600	1	1972 Ranchero GT
2	'76 Gran Torino	2	'71 Mustang Mach 1
3	'68 Mustang GT	3	'76 Gran Torino
4	'71 Mustang Mach 1	4	'66 Fairlane GT
5	'66 Fairlane GT*	5	'64 Galaxie 500*
6	'64 Galaxie 500*	6	66 Thunderbird Convertible*

### Modern

Start up		Update	
Europe		US	
1	1978 Mk III Capri 3.0S	1	Crown Victoria*
2	SVT Focus	2	SVT Focus
3	SVT Cobra	3	SVT Cobra
4	2004 Mondeo ST220	4	2003 Limited Edition Thunderbird
5	1999 Racing Puma*	5	Powerstroke Concept
6	2004 SVT Lightning*	6	2004 SVT Lightning*

### Performance

Start up		Update	
Europe		US	
1	Focus FR200*	1	Focus FR200
2	1992 Escort RS	2	Indigo Concept
3	Ford GT	3	Ford GT
4	2005 Mustang GT	4	2005 Mustang GT
5	1987 Sierra RS500	5	Mustang FR500*
6	FR100 Concept*	6	FR100 Concept*

### Off road

Start up		Update	
Europe		US	
1	1999 Focus Rally Car	1	Ex Concept
2	1973 Escort RS2000	2	2004 F-150 FX4
3	1985 RS200	3	F-350 XLT Sport
4	F-350 XLT Sport	4	F-150 4x4 Flareside
5	Ex Concept*	5	'65 F-100*
6	2004 F-150 FX4*	6	'56 F-100*

The tables below detail the tracks available to select initially and after the preset update day.

**Initial Tracks**

<b>Road Tracks</b>		<b>Off Road Tracks</b>	
1	Harbour – Forward	1	White Sands - Reverse
2	Railroad – Reverse	2	Voodoo Village - Forward
3	Quaker Town – Forward	3	Colonial Grounds - Reverse
1	Mountain Village - Forward	1	Fishing Town - Forward
2	Summit Trials - Reverse	2	Logging Company - Reverse
3	Race Track	3	Oil Refinery – Forward

**Update Tracks**

<b>Road Tracks</b>		<b>Off Road Tracks</b>	
1	Harbour – Reverse	1	White Sands - Forward
2	Quaker Town – Reverse	2	Voodoo Village - Reverse
3	Race Track	3	Colonial Grounds – Forward
1	City Highway - Forward	1	Fishing Town - Reverse
2	Mountain Village - Reverse	2	Logging Company - Forward
3	Summit Trials - Forward	3	Oil Refinery - Reverse

NOTE: The updated tracks become available only when the AUTO UPDATE has taken place.

Please see the next section in this manual regarding the UPGRADE of software.

## 12. UPGRADES

### UPGRADES

This product comes with an AUTOMATIC upgrade in software.

On the 1<sup>st</sup> November 2006 the machine will perform an AUTOMATIC UPGRADE and the software will be updated to give the player a number of NEW racing track and NEW cars.

28 days prior the OFFICIAL software drop, players will be advised that an UPGRADE will take place. The machine will display a 28 DAY counter during the attract mode.



- Only QUALIFIED SERVICE PERSONEL should carry out updates in software.

Once the UPGRADE has taken place the operator is able to access the GAME TEST MODE and chooses to enable either UPGRADE or STANDARD version by turning the UPGRADES ON/OFF.

```
GAME TEST
Language : english
DifficultyLevel : medium
SoundEffectsVolume : high
SpeechVolume : high
AmbientVolume : high
IngameMusicVolume : high
MenuMusicVolume : high
AttractModeVolume : high
-> EXIT

SELECT WITH SERVICE BUTTON
AND PRESS TEST BUTTON
```

GAME TEST SCREEN BEFORE UPGRADE

```
GAME TEST
UPGRADES : ON
Language : english
DifficultyLevel : medium
SoundEffectsVolume : high
SpeechVolume : high
AmbientVolume : high
IngameMusicVolume : high
MenuMusicVolume : high
AttractModeVolume : high
-> EXIT

SELECT WITH SERVICE BUTTON
AND PRESS TEST BUTTON
```

GAME TEST SCREEN AFTER UPGRADE

## 13. HANDLE MECHANISM



- Be sure to turn power off before performing work.
- Immediately after the game has finished, the motor may still be very hot after operation. When performing any work when handling the motor is necessary, wait until the motor has cooled.
- This unit is HEAVY. Please take care when removing.

In the TEST MODE, if the steering wheel's V.R. variations are not within the allowable range then replacement of the V.R. is needed. Also be sure to apply grease to the gears of the V.R. mechanism once every 3 months to provide optimum operation.

### 13.1. REMOVING THE CONTROL PANEL

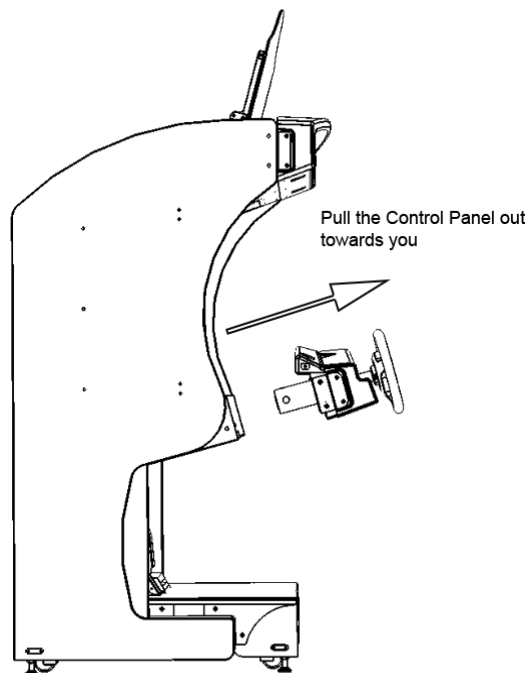
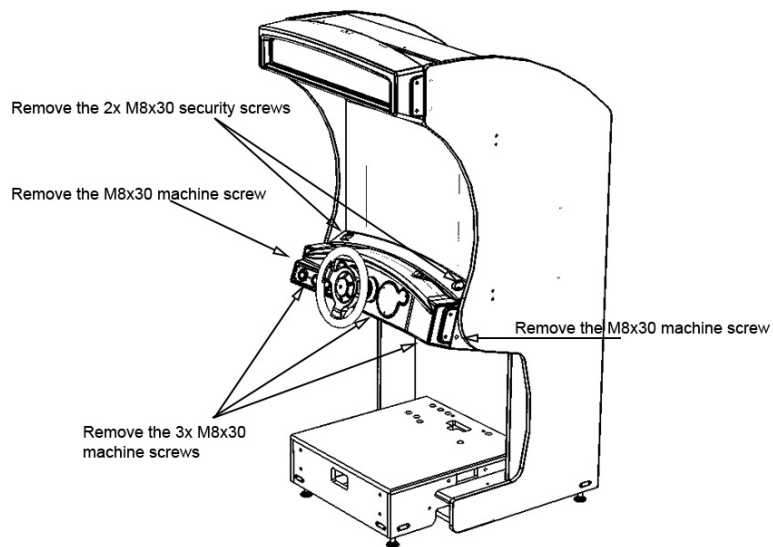

**IMPORTANT:**

DISCONNECT ALL POWER BEFORE REMOVAL. DISCONNECT ALL HARNESSSES BEFORE REMOVAL

## 13.2. REPLACING AND ADJUSTING THE HANDLE'S V.R.



- Never touch places or parts other than those specified. Touching places not specified may cause electric shock or a short circuit hazard.



- After the replacement or adjustment of the steering V.R., be sure to set the centering value of the V.R in test mode.

### REPLACING THE V.R

1. Turn off the power.
2. Disconnect the connectors.
3. Take out the screws which secure the V.R bracket and remove.
4. Remove the screws which retain the gear to the V.R.
5. Reconstruct in reverse order.
6. After replacing the V.R., perform the adjustment in CALIBRATION TEST.

### ADJUSTING THE VOLUME

1. In the CALIBRATION TEST, have the steering calibration test active.
2. Loosen the two screws which secure the bracket to disengage gears.
3. With the steering in the centre position, revolve the gear which is secured to the V.R to the centre position.
4. Realign the gears and secure the bracket.
5. Perform V.R settings in the CALIBRATION TEST.

### 13.3. GREASING



- Be sure to use suitable grease for the purpose. Using a non-suitable product may cause damage to parts.

*Apply the grease to the V.R gear once every 3 months for optimum performance.*

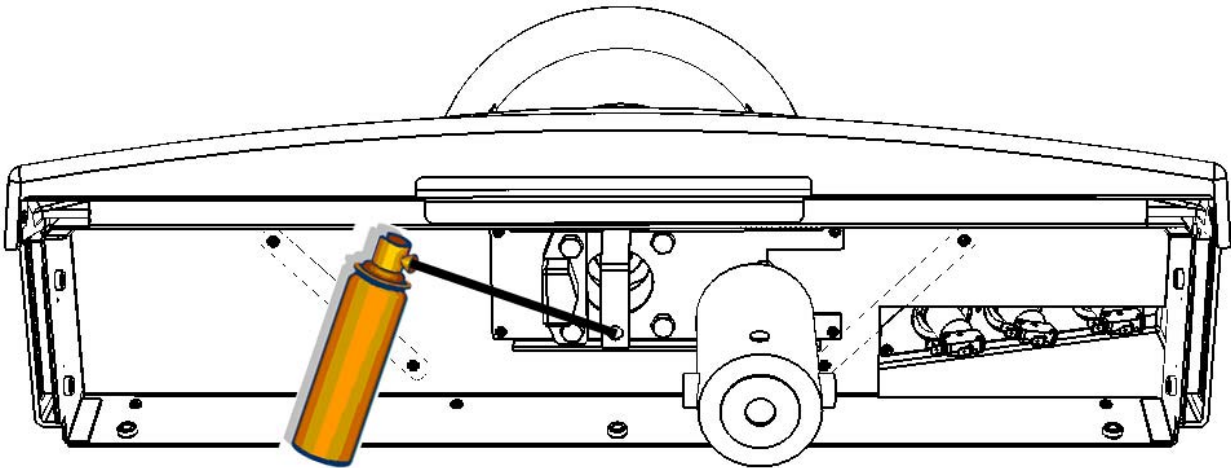

GREASE AT THIS POINT EVERY 3 MONTHS

## 14. SHIFT LEVER



- Before starting work, ensure that the Power is disconnected and the machine is switch off. Failure to observe this precaution may cause injury or electric shock.
- Use care so as not to damage wiring. Damaged wires can cause electric shock or a short circuit hazard.
- Do not touch undesignated places. Touching places not specified can cause electric shock or short circuit hazards.

If the Shift Lever operation is not satisfactory, remove the Shift Lever in the following procedure to replace the microswitch.

### 14.1. REMOVING THE SHIFT LEVER

1. Turn the power off and disconnect the machine from the electrical supply.
2. Remove the 4 machine screws located at the top near the lever knob.

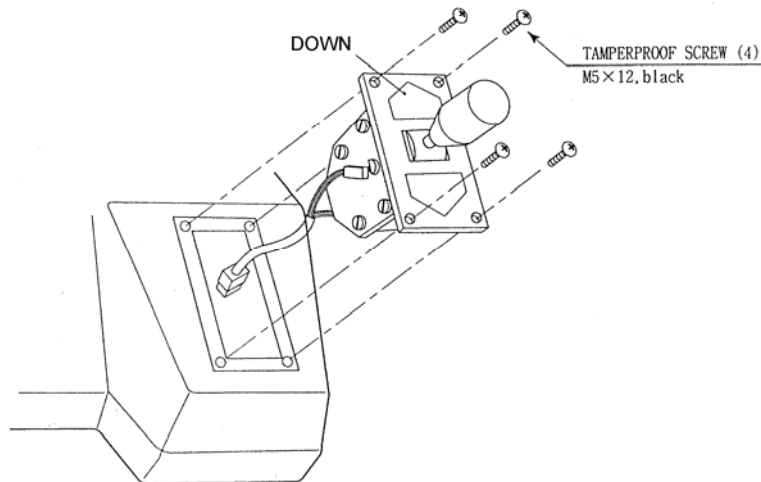

3. Disconnect and remove the unit completely.
4. Reinstall in reverse order, ensure the label marked

## 14.2. SWITCH REPLACEMENT

Each Microswitch is secured using 2 machine screws. Remove the 2 screws and replace the Microswitch using the illustration below.

1. Disconnect the wiring connectors of the switch which is to be replaced.
2. Remove the 2 self tap screws to remove the Microswitch.

## GREASING

Apply grease once every 3 months to the specified areas to ensure smooth operation throughout the product life.

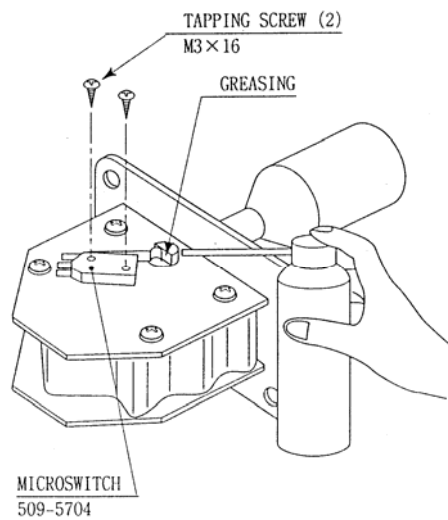



## 15. ACCELERATOR & BRAKE



- Before starting work, ensure that the Power is disconnected and the machine is switch off. Failure to observe this precaution may cause injury or electric shock.
- Use care so as not to damage wiring. Damaged wires can cause electric shock or a short circuit hazard.
- Do not touch undesignated places. Touching places not specified can cause electric shock or short circuit hazards.

If the Accelerator and Brake operation is not satisfactory, adjustment of the volume installation position or V.R. replacement is needed. Also, be sure to apply greasing to the gear portion once every 3 months.

### 15.1. ADJUSTING AND REPLACING THE V.R.

The appropriate value of each V.R. is 5K Ohms.

Since work is performed inside the energized cabinet, be careful so as not to touch undesignated portions. Touching places not specified can cause electric shock or short circuit.

- 1 Take out the 2 truss screws and remove the front cover from the Accelerator and Brake Unit.

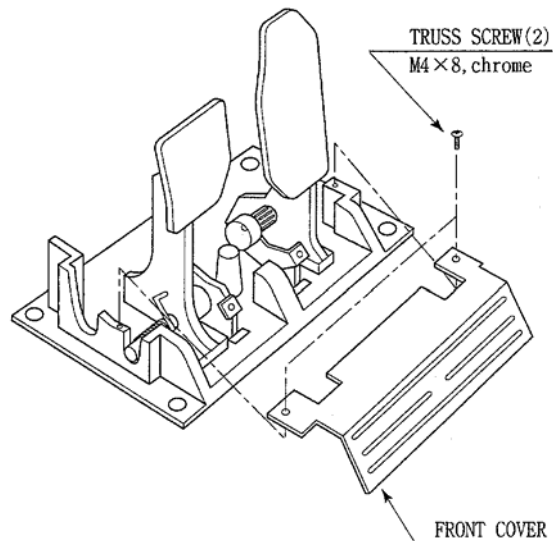

- 2 Loosen the screws which secure the base and adjust the Potentiometer value by moving the base

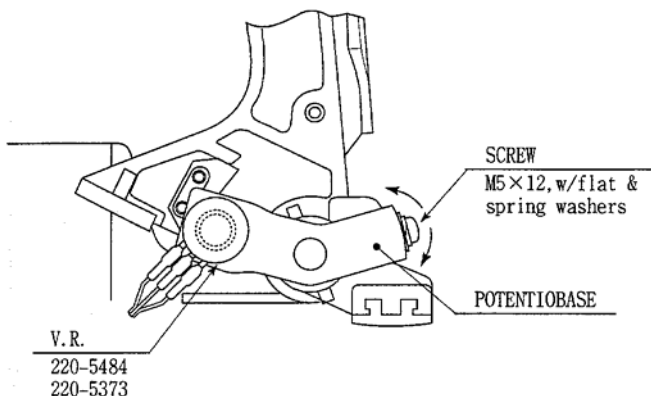

## REPLACING THE POTENTIOMETER

1. Turn the power off.
2. Take out the 2 screws and remove the top cover.

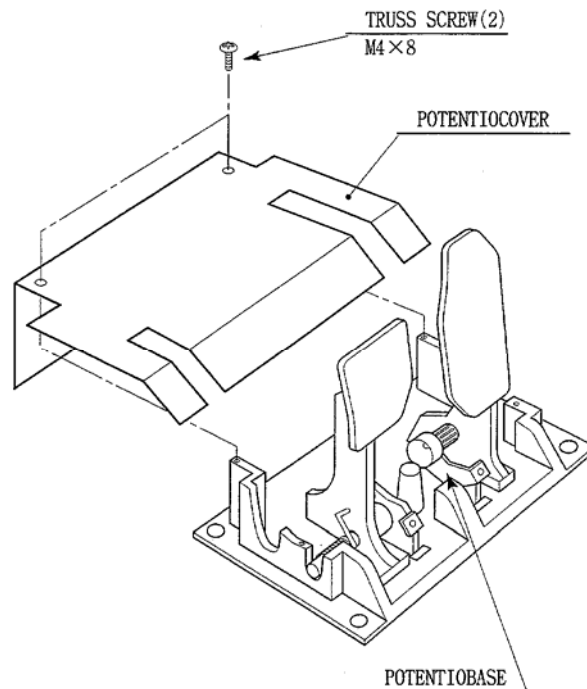

3. Disconnect the connector of the volume pot to be replaced.
4. Remove the screws which secure the Potentiocover.
5. Remove the Potentiobase together with the Potentiometer.
6. Remove the base and gear and replace.

## GREASING



- Be sure to use suitable grease for the purpose. Using a non-suitable product may cause damage to parts.

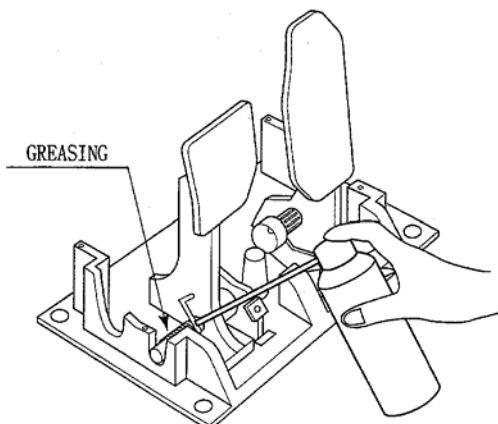

## 16. COIN SELECTOR

### HANDLING COIN JAMS

If the coin is not rejected when the REJECT button on the COIN CHUTE DOOR is pressed, open the COIN CHUTE DOOR and open the selector gate. After removing the jammed coin, put a normal coin in through the COIN ACCEPTOR and check to see that the selector correctly functions.

### CLEANING A MECHANICAL COIN SELECTOR



- Remove and clean smears by using a damp soft cloth.
- Never apply oil, etc. to the Coin Acceptor.
- After cleaning the Coin Acceptor, insert a regular coin in the normal working status and ensure that the Selector correctly functions.

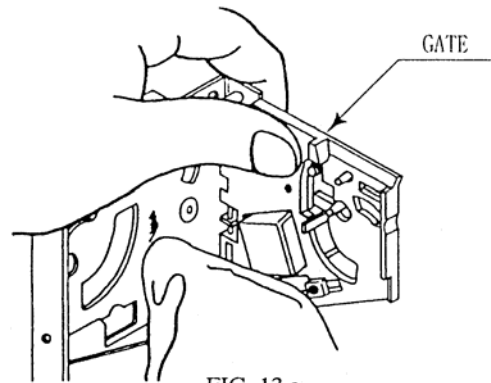

FIG. 13 a

The Coin Acceptor should be cleaned once every 3 months. When cleaning, follow the procedure below.

1. Turn the power for the machine to the OFF position and open the Coin Chute Door.
2. Open the Gate and dust off by using a damp lint free cloth.
3. Remove and clean smears by using a soft lint free cloth dipped in water of mild detergent and squeezed dry.
4. Remove the cradle. When removing the retaining ring, be very careful so as not to bend the rotary shaft.
5. Remove any foreign bodies from the rotary shaft and pillow portions by wiping off the cloth.
6. After wiping off as per previous instruction, apply a dry lint free cloth to dry the affected areas properly.

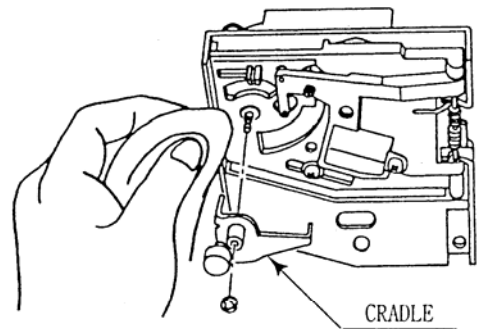
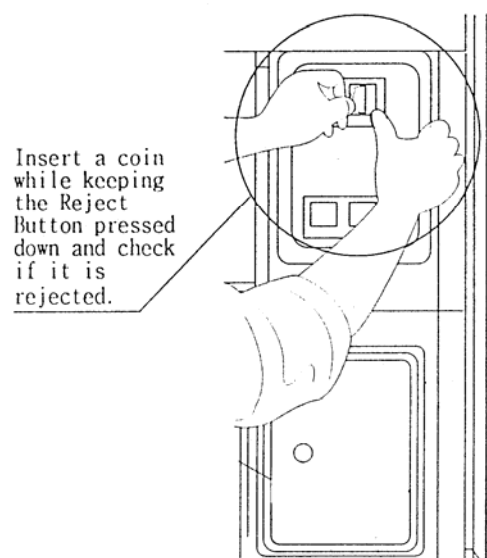

FIG. 13 b

### CLEANING A MECHANICAL COIN SELECTOR

Once every month, when performing the Coin SW Test, simultaneously check the following.

- Does the Coin Counter count satisfactory?
- Does the coin drop into the cashbox correctly?
- Is the coin rejected when inserted while keeping the Reject Button pressed down?



## 17. MONITOR

### 17.1. CAUTIONS CONCERNING THE SAFETY ISSUES WHEN HANDLING THE MONITOR.

Before handling the monitor(s), be sure to read the following explanations and comply with the caution/warning instructions given below. Note that the caution/warning symbol marks and letters are used in the instructions.



- When performing such work as installing and removing the monitor, inserting and disconnecting the external connectors to and from the monitor interior and the monitor, be sure to disconnect the power connector (plug) before starting work. Preceding the work without following this instruction can cause electric shock or malfunction.
- Using the monitor by converting it without obtaining prior permission is not allowed. SEGA shall not be liable for any malfunctioning or accident caused by unauthorised work being carried out.



- Primary side and Secondary side. The monitor's circuit which is divided into the Primary side and Secondary side are electrically isolated. Do not touch the primary side, or do not touch both the primary side and the secondary side simultaneously. Failing to observe the instruction can cause electric shock and this is very dangerous. When making monitor adjustments do not touch any part of the monitor assembly, this can cause malfunction and or an electric shock. Also, be sure as to not cause a short circuit condition between the primary and secondary side of the assembly. This can be very dangerous and may cause electric shock hazard.

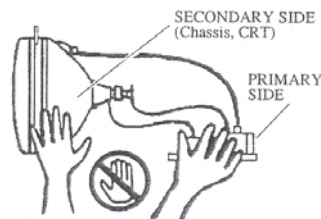

- UHT. Ultra High Tension. Some of the parts contained on / in the monitor assembly are subject to UHT. UHT voltage can be in excess of 25,000 volts and is very dangerous. Therefore, do not touch the monitor interior. Should solder or any other debris come into contact with the internal components of the monitor, turn the power OFF so as not to cause a malfunction or fire hazard.

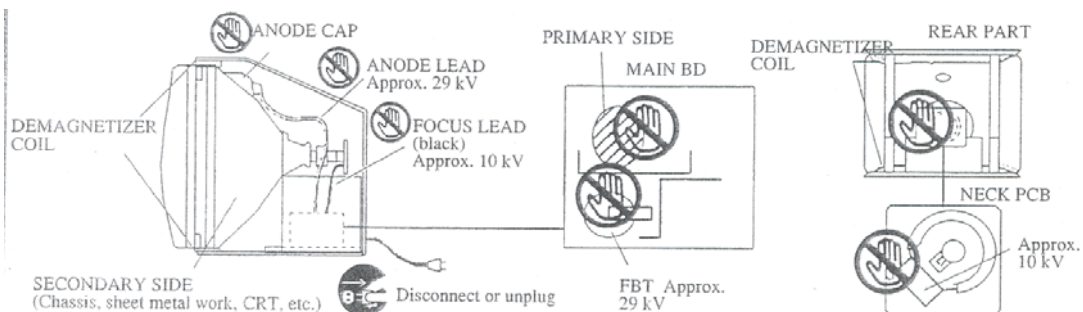



- Static electricity. Touching the CRT surface can sometimes cause static electricity. This is because the CRT surface is subject to static and will not adversely affect the human body.
- Installation and removal.. Ensure that the Degause Coil, Fly Back Transformer, Anode Lead and Focus leads are not positioned close to sheet metalwork sharp edges. This is to avoid damaging the insulation and not to cause electric shock and or malfunction.



- For the purpose of static prevention, special coating is applied to the CRT face of this product. Damage to the coated film can cause electric shock to the engineers of maintenance persons. Take heed when cleaning.
- DO NOT apply or rub with hard or abrasive material any components directly onto the CRT surface.
- Avoid applying stickers, seals on the surface of the CRT.
- DO NOT remove aluminium foils from the CRT corners. Removing these foils can remove any static electric prevention.

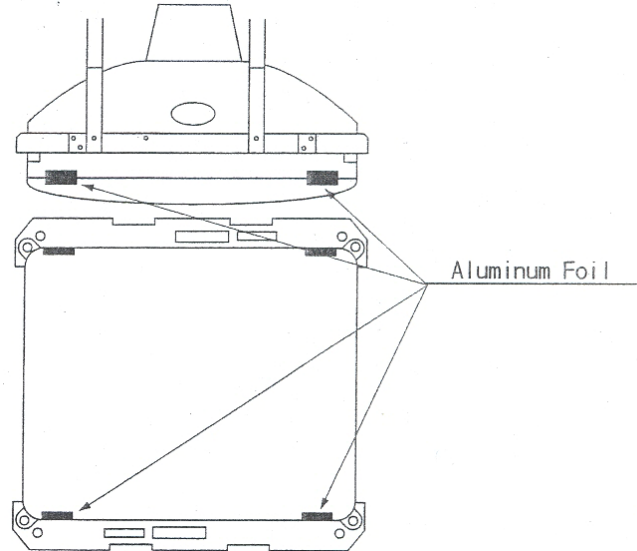

## 17.2. CAUTIONS TO BE AWARE OF WHEN CLEANING THE CRT SURFACES



- Static prevention coating is applied to the CRT surface. When cleaning, pay attention to the following points. Peeling off the preventative coat can cause electric shock.
- Remove smears, smudges by using a soft cloth. Do NOT use a coarse gauze or similar product.
- When using a chemically based detergent, be sure to follow instructions below:
  - Dilute chemical detergent with water and dip an area of the cloth into it. Squeeze cloth of all excess water. Wipe screen thoroughly to remove greasy smears or smudges.
  - Do not use a chemical cleaning compound, any abrasive cleaning agent or bleach like products.
  - Do not use alkaline chemical detergents such as "glass cleaner" and avoid all solvents and thinners.
- Do not rub or scratch the CRT surface with hard items such as a brush or finger nails etc.

Clean the CRT surface once every 3 months or when the screen looks dirty.

### 17.3. ADJUSTING THE PICTURE



- Monitor adjustments have been made at the time of shipment. Therefore, do not make further adjustments without a justifiable reason. Adjusting the monitor which contains high tension parts is a dangerous task. Also, an erroneous adjustment can cause deviated synchronization and image fault, resulting in malfunction.
- When making adjustments to the picture, take care when handling the remote controller board.

To make monitor adjustments, remove the 2 Truss Head screws from the CRT Adjustment panel. Remove the panel and the Remote Controller board. Do not pull on the CRT adjustment panel as the wires connecting the Remote Controller board to the Monitor board can become disconnected if pulled too hard.

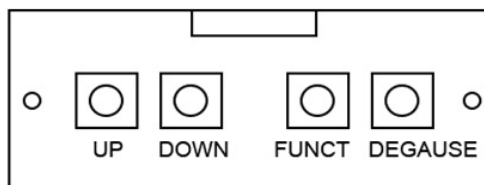
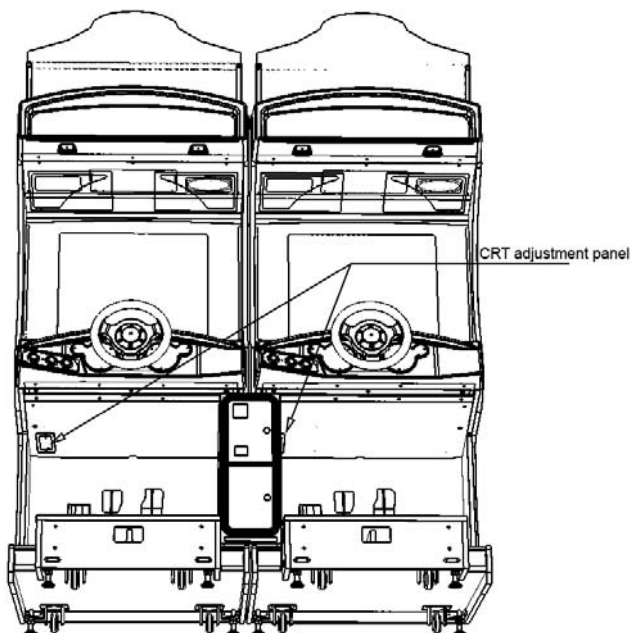

MONITOR CONTROL BOARD

#### OPERATING THE MONITOR CONTROL BOARD

1. Press the "Function" button to display the MENU screen.

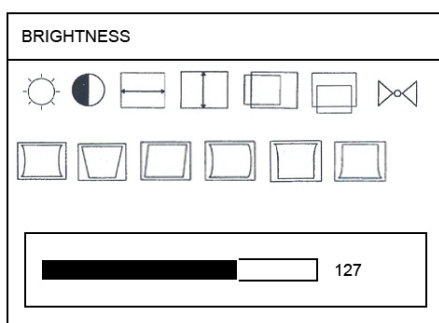

Monitor Control Menu as displayed on screen

2. To adjust the "brightness" use the "UP DOWN" button to move the flashing cursor to the BRIGHTNESS symbol.
3. To select the option, press the "FUNCTION" to engage the operation.
4. The selected icon will flash and by using the "UP DOWN" buttons the value of the set criteria can be changed to the required value.
5. Once the required value is set, press the "DEGAUSE" button to exit back to the main menu.
6. Repeat the process to adjust different options.

**PLEASE REFER TO THE MONITOR MANUAL FOR COMPLETE OPERATING INSTRUCTIONS**

## 18. REPLACEMENT OF FLUORESCENT LAMPS



- When performing any work, be sure to turn power off. Working with power on can cause electric shock and short circuit.
- The Fluorescent lamp can get hot towards the ends of the unit. Be careful when



- To perform work safely and securely, be sure to prepare a step which is in a secure condition. Performing work without a step can cause accidents.

Remove the 4x M4 screws from the Pop Panel Mounting Bkt and remove.

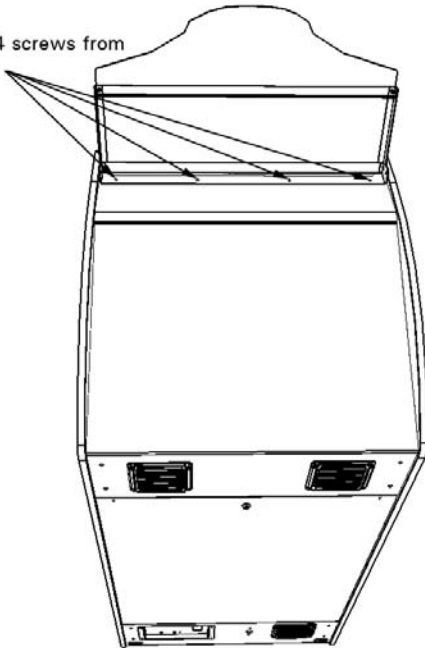

### IMPORTANT.

Please wait for approximately 10 to 15 minutes for the lamp to cool down before attempting to remove.

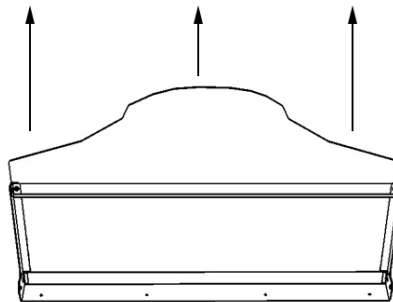

Remove clear plate from top of the cabinet

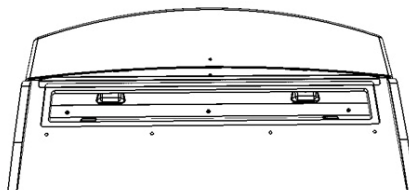

Remove the protective cover from the lamp and twist the lamp to remove.

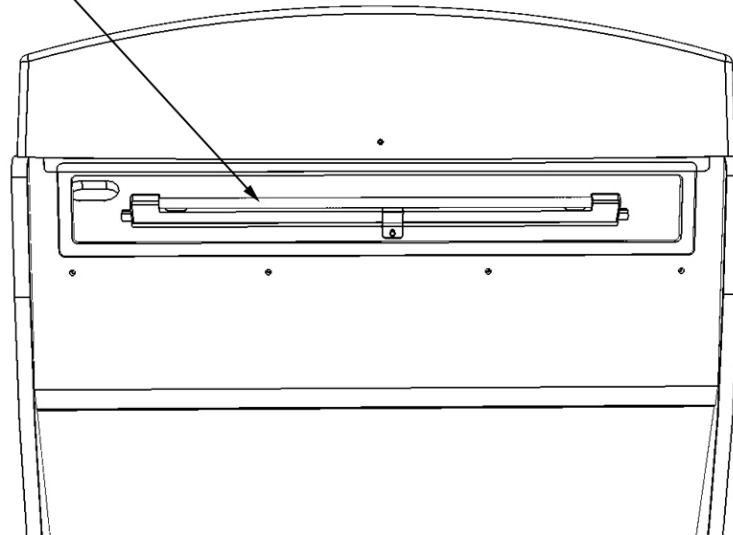

Once removed, replace the lamp with new and reassemble in reverse.



## 19. REPLACEMENT OF BUTTON LAMPS



- Before starting work, ensure that the Power is disconnected and the machine is switch off. Failure to observe this precaution may cause injury or electric shock.
- Use care so as not to damage wiring. Damaged wires can cause electric shock or a short circuit hazard.
- Do not touch undesignated places. Touching places not specified can cause electric shock or short circuit hazards.

Remove the 4x M4 Torx screws from the ASSY SW and remove

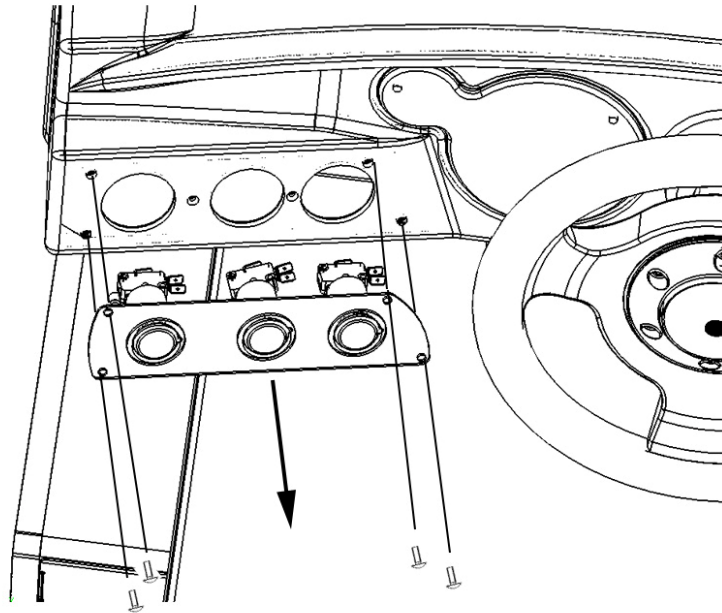

Undo the machine screws using a TORX T20 Security drive tool. (not supplied)

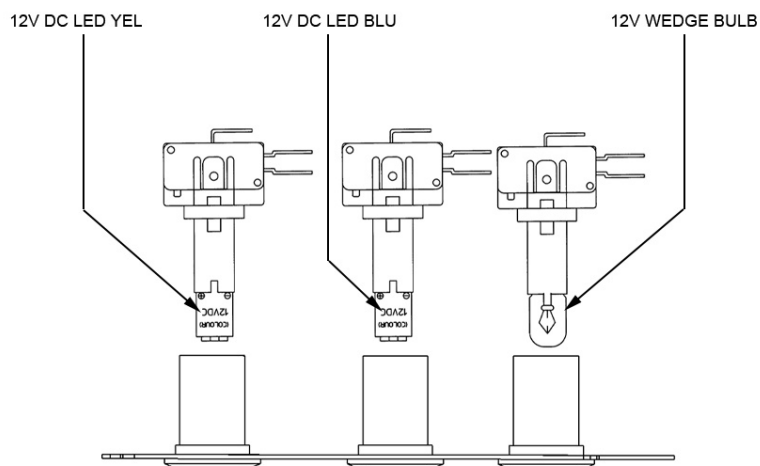

Pull the BULB HOLDER out of the Button to remove

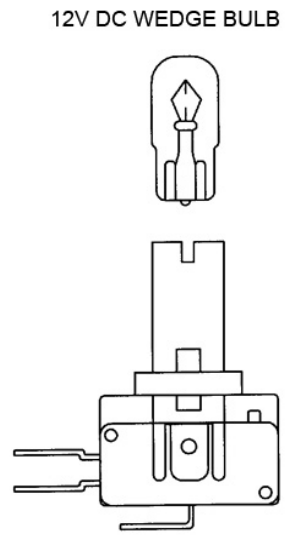
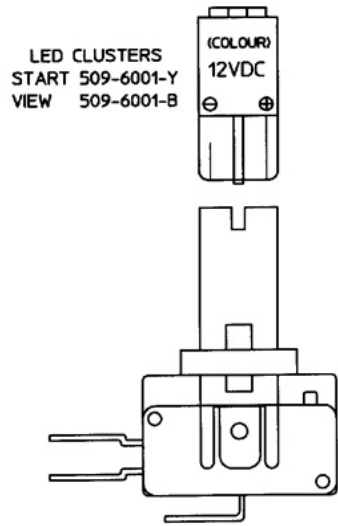

Replace the bulb or LED with the correct type and reverse process to re-assemble.

## 20. GAME BOARD



- In order to prevent electric shock and short circuit hazard, be sure to turn power off before commencing work.
- Be careful so as not to damage wiring. Damaging wiring can cause fire, electric shock and / or short circuit.
- Do not expose the GAME BD, etc. without a good reason. Failure to observe this can cause electric shock hazard or malfunction.



- The electronic parts contained within the GAME BD CASE can be damaged due to human body static electricity. Before performing and component level work, be sure to gain acknowledgement from SEGA.
- Before attempting component level work be sure to discharge physically accumulated static by touching grounded metallic surfaces.

### 20.1. REMOVING THE GAME BD

To replace the IC BD (such as the Game BD, UCGI BD, etc.) please use the following procedure.

1. Turn the MAIN SW off and disconnect the MAINS LEAD from the machine.
2. Remove the 2 truss screws which secure the rear door to the cabinet and unlock the door.

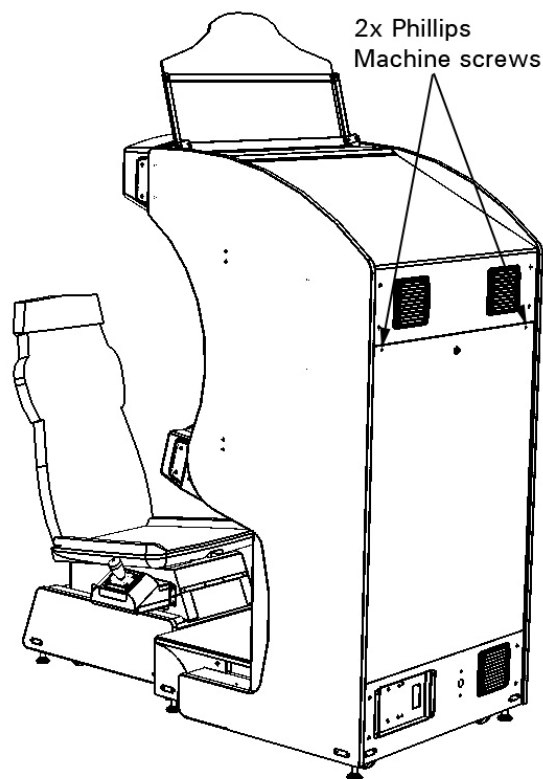

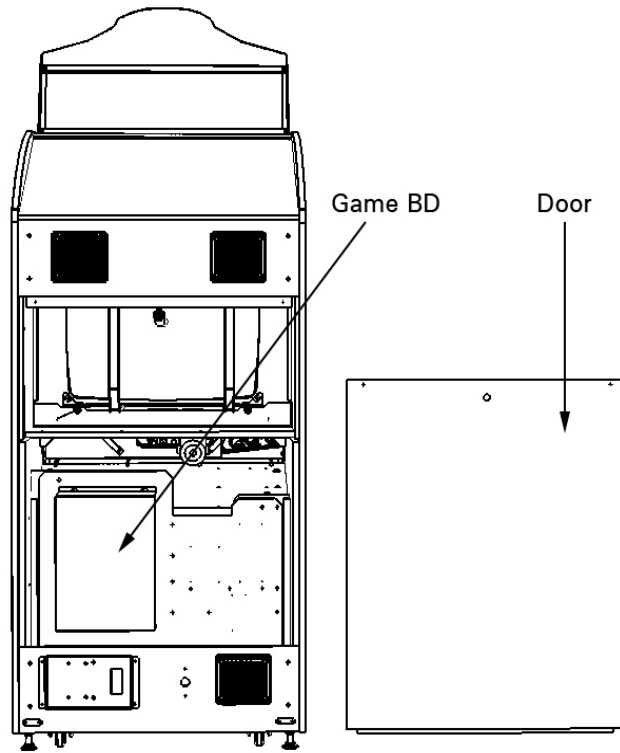

3. Remove the rear door and set safely to one side.

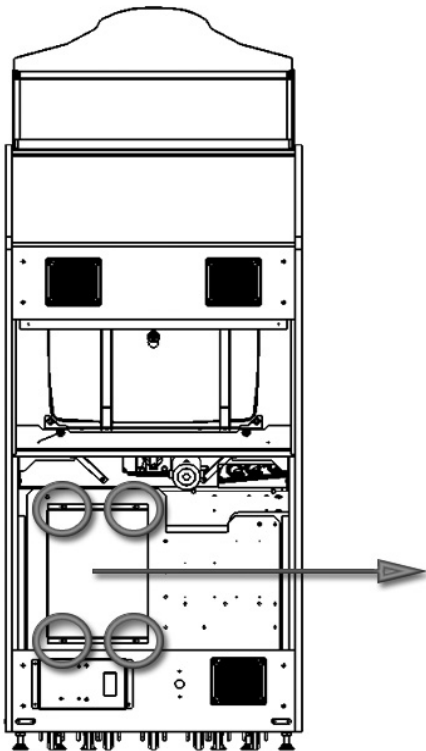

4. Disconnect all harnesses from the Game Board.
5. Remove the Security Device.
6. Loosen the four (4) self tapping screws.
7. Slide the Game Board to the right and remove.
8. Repeat the process to re-assemble.

## 20.2. GAME BOARD CONNECTIONS



- When the security device is installed, the Game Board becomes proprietary to this product.



- For safety reasons the GAME BOARD is fitted with a 10 second power on delay. If power is turned OFF and ON again within the 10 seconds delay period, the GAME BOARD will NOT power up. Please wait a full 10 seconds before applying power.

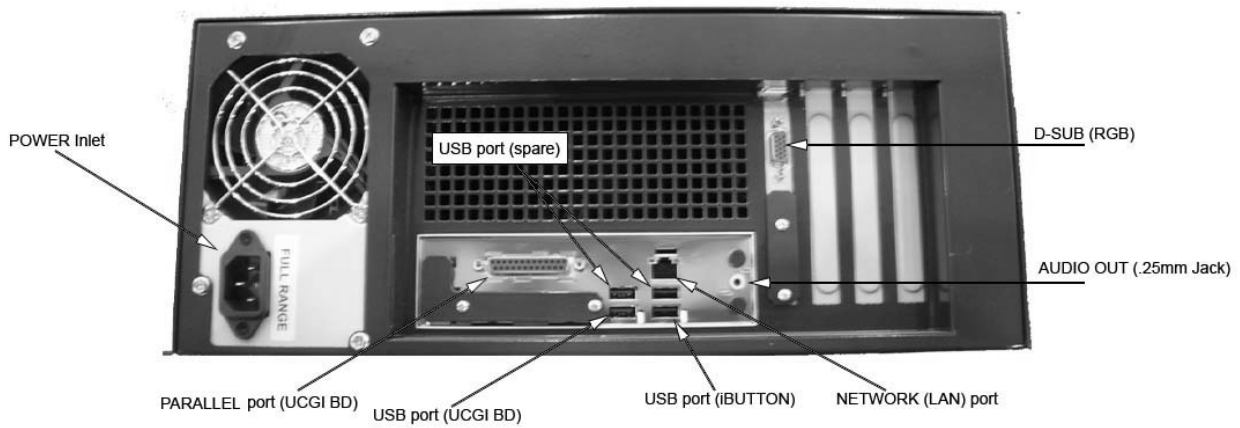

DESCRIPTION	OPERATION
POWER INLET	240VAC IEC Inlet
PARALLEL PORT	I/O from UCGI DB
USB PORT 1	Communication from UCGI BD
USB PORT 2	iBUTTON Port
NETWORK	LAN connection to HUB
AUDIO OUT	Stereo output to Audio Amp
D- SUB	Analogue RGB output



## 21. NETWORK PLAY

Up to 3 twins (6 seats) can be linked for network play. Properly connected network cables and correct network play settings are required for network play.



- Before starting to work, ensure that the Power SW is OFF. Failure to observe this can cause electric shock or short circuit.
- Use care so as not to damage wiring. Damaged wiring can cause electric shock or short circuit.
- Do not touch undesignated places. Touching places not designated can cause electric shock or short circuit.
- This work should be performed by a Qualified Service Personnel. Performing work by a non qualified person can lead to an electric shock or short circuit hazard.
- When linking a number of machines, be sure to apply sufficient power for the corresponding number of machines. Be sure to secure the correct current per machine as stated in this manual. Failure to observe this can cause fire and or electric shock.
- Due to the length of network cable, the distance in between the machines is limited. However, to avoid accidents, be sure to secure space in excess of 70cm between machines.
- To perform work safely and avoid serious accident such as the machine cabinet toppling over, do not perform work in places where step like grade differences exist.
- To avoid accidents, use a cable cover that will not cause patrons to trip.



- Network play is not possible between games of different types.

SPACING OF THE GAME MACHINES

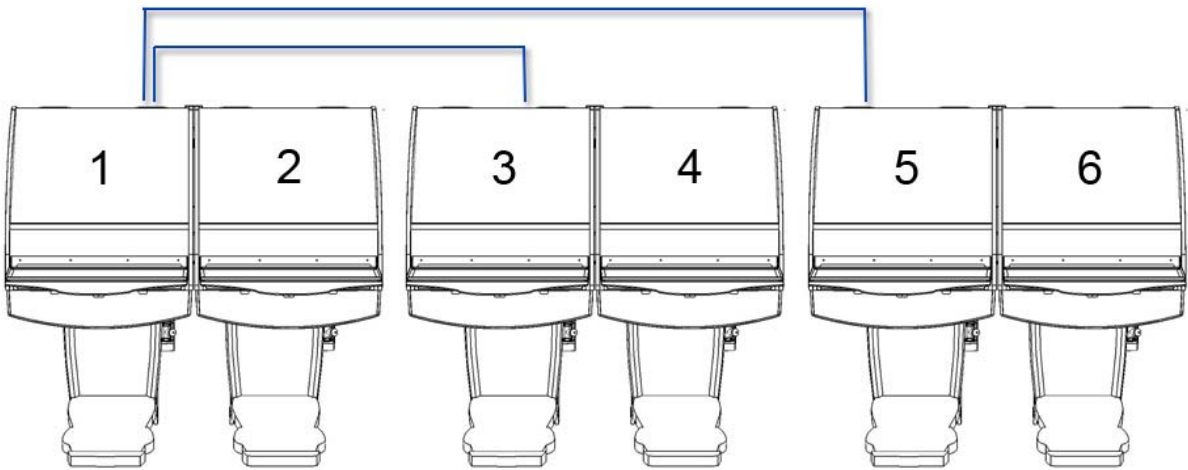

Diagram to link 3 twins for network play

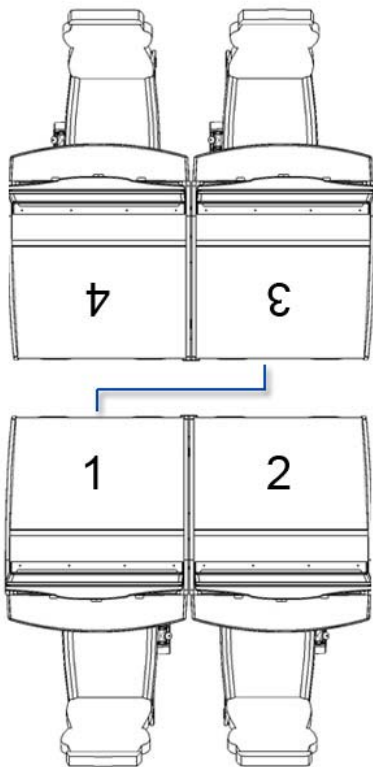

Diagram to link 2 twins for network play



## 21.1. CONNECTIONS FOR NETWORK PLAY

To enable network play, the hubs inside each of the master game machines must be connected with network (LAN) cables. Connect the hub inside the master machine to each of the hubs inside the other machines.

Do not make the LAN connections between this game and another game of a different type.

1. Turn the power off and unplug the power cord from the outlet. Place the power cord so as not to damage it while working.
2. Move the machines so that they are aligned as explained in section 20 of this manual. Leave enough space at the rear and the sides of the machine so that work can be performed safely.
3. Remove the back door(s) of the master units and feed a LAN cable between each hub (as shown in the diagram on previous page).
4. Feed the excess cable back into the machine or lay cable cover as to not cause a tripping hazard.

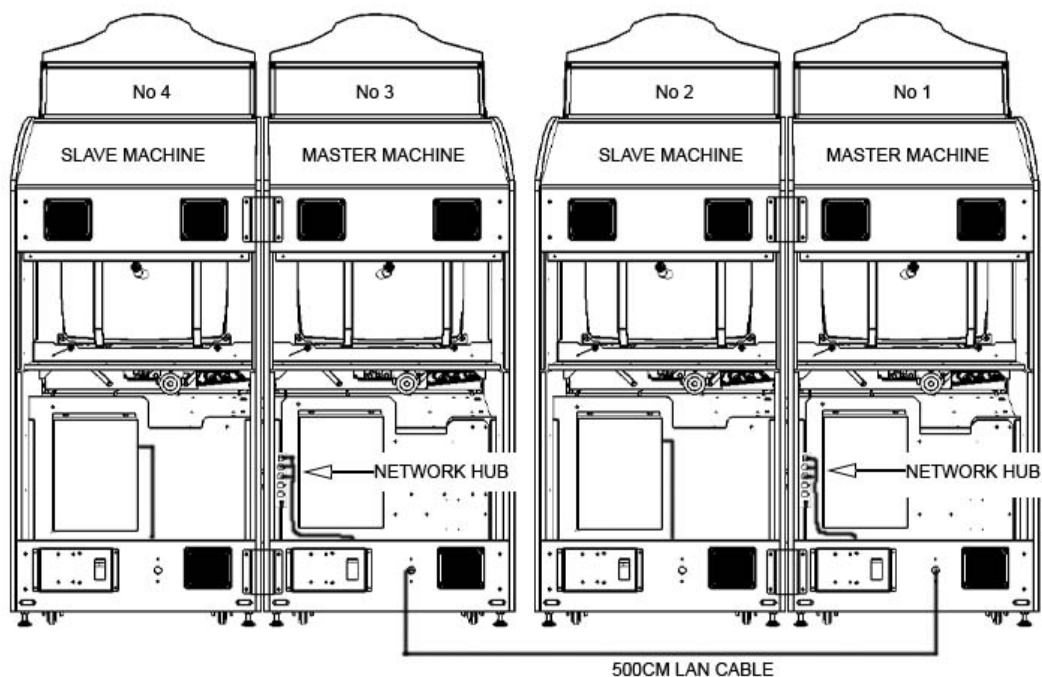

5. Power on the machine and enter the SYSTEM TEST mode by pressing the TEST button located on the VTS PCB located inside the COINCHUTE TOWER.
6. Using the SERVICE button, navigate to the NETWORK TEST option and press the TEST button to enter.
7. Change the CABINET ID to read CABINET ID 1, CABINET ID 2, CABINET ID 3 and CABINET ID 4 from left to right. (see diagram)
8. Once ALL changes have been met use the SERVICE button to navigate to "CONFIRM CHANGES" on each machine.
9. The machine will no reboot with the changes.

See section 21.2 on "HOW TO SET UP A MACHINE FOR NETWORK PLAY."

## 21.2. NETWORK PLAY SETTINGS

Each for the linked machines must be set up for network play. If the machines are not set up correctly, network play will not be possible.

### HOW TO SET UP THE MACHINE FOR NETWORK PLAY

1. Turn the power off on each machine to be used for network play.
2. Enter the test mode on each machine. (see section 9-2)
3. Select the SYSTEM TEST mode and press the TEST button. The machine will enter System Test mode and the screen will display the System Test Menu.
4. Select Network Settings from the System TEST menu and press the TEST button. The NETWORK TEST SCREEN WILL APPEAR.

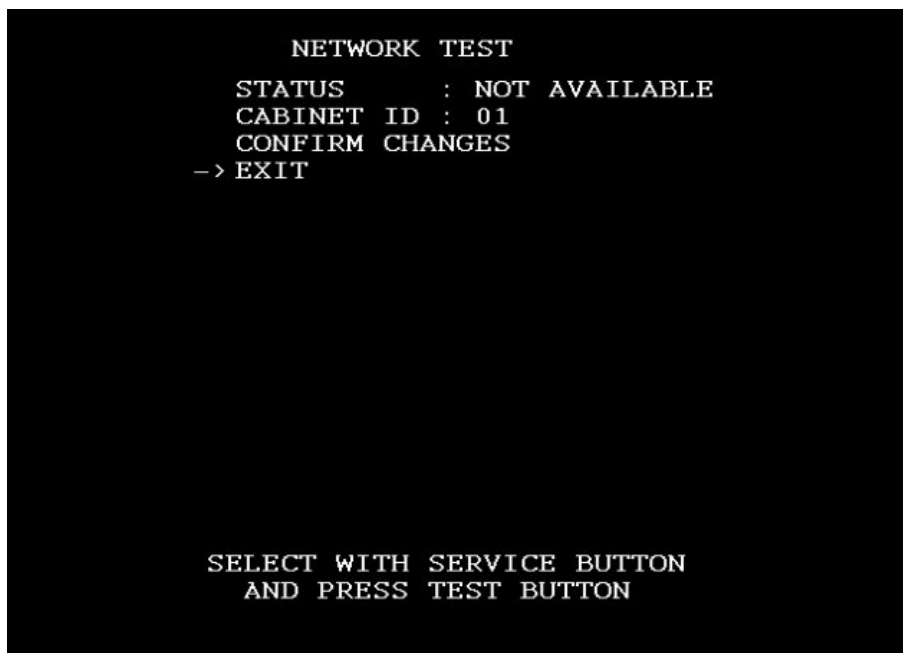

5. Set the CABINET ID so that each machine displays a different number. For example, machine No1 will be labelled 1 and machine No2 will be labelled 2 and so on.
6. Once all machine have been given their unique identity number, press the SERVICE button to bring the selection to CONFIRM CHANGES.
7. Press the TEST button to execute the changes. All units will reboot and come back online in linked play.

## 22. COIN SETTINGS

Game credits between the Coin Mechanism and the game board for this machine are controlled by a **VTS board**. This electronic circuit allows the price of play to be set for a range of different countries. These functions are set on Dual In Line (DIL) PCB mounted switches.

DIL-2 is used to set the currency (or coin ratio) and DIL-1 the price of play. Refer to the Tables on the following pages for the correct settings for your environment.

The *Klingon2* board pictured below is mounted on the VTS Bracket within the Coin Chute Tower.

The *Klingon2* board is connected to the coin validator and lamps via a dedicated wiring harness depending upon the coin validator used:

Wiring Harness	Validator	
LM1006	Coin Controls	(15 way connector)
LM1007	Mars	(13 way connector)
LM1008	Mechanical	See note 2
N/A	NRI	See note 1

### Notes

1. If NRI mechanisms are to be used, these should be ordered with the highest denomination coin on coin path #1 and the lowest denomination on coin path #4. The VTS board should be then be set up for either the UK or EURO settings. A minimum connecting lead length of 600mm is required.
2. Mechanical coin mechanisms may be connected in parallel allowing two identical mechanisms to be fitted.

Illustration showing COIN TOWER, VTS PCB, COIN VALIDATOR and ASSOCIATED HARNESSSES



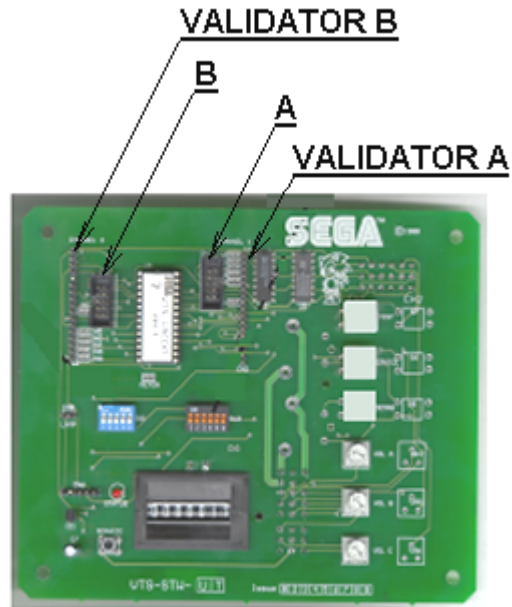

Illustration shows VTS PCB.

All COIN ASSIGNMENTS are carried out and processed by the VTS Board. This game uses a single SR3 Coin Validator (if supplied). This Validator will connect into port A as indicated by the illustration above.

All Credit settings are configured via the DIP switches also located on the VTS Board (please refer to later on in this manual for the appropriate switch settings).

**IMPORTANT** – The CREDIT SETTINGS as displayed in the COIN TEST of the SYSTEM TEST MENU. This should always be set to 1 COIN = 1 CREDIT to maintain a correct output from the VTS.

## 22.1. VTS CREDIT BOARD OPTION SETTINGS

Credit Board Mode Settings Switch 3																				
Country	Setting	Switch 3 Setting						Coin Validator Programming								C120/SR3 Only				
		SW1	SW2	SW3	SW4	SW5	SW6	COIN1	COIN2	COIN3	COIN4	COIN5	COIN6	COIN7	COIN8	COIN9	COIN10	COIN11	COIN12	
UK	Coin Controls C220 Parallel	OFF	OFF	OFF	OFF			£1	50p new	20p	10p	-	50p old	-	-					
UK	Coin Controls C220 Binary	ON	OFF	OFF	OFF			£1	50p new	20p	10p	-	50p old	-	£2					
UK	Coin Controls C220 Binary	OFF	ON	OFF	OFF			£1	50p new	20p	10p	-	£2	-	50p old					
UK	Coin Controls SR3 Parallel	ON	ON	OFF	OFF			£1	50p new	20p	10p	-	£2	-	50p old	-	-	-	-	
UK Euro	Coin Controls SR3 Parallel	OFF	OFF	ON	OFF			£2 €2	£1 €1	50p new 50¢	20p 20¢	10p 10¢	-	-	-	50p old	-	-	-	
UK	Mars ME/MS 111 Parallel	ON	OFF	ON	OFF			£1	£2	20p	10p	50p new	50p old							
UK	NRI Parallel	OFF	ON	ON	OFF			10p	20p	50p	£1	£2	-							
Belgium	Parallel	ON	ON	ON	OFF			-	50Bfr	20Bfr	5Bfr									
Holland	Parallel	OFF	OFF	OFF	ON			-	5NLG	2.5NLG	1NLG									
Austria	SR3 Parallel	ON	OFF	OFF	ON			20Sch	10Sch	5Sch	1Sch									
Spain	Coin Controls C220 Binary	OFF	ON	OFF	ON			500Pta	200Pta	100Pta	50Pta	25Pta	200Pt old	50Pta old	25Pta old					
Spain	SR3/NRI Parallel	ON	ON	OFF	ON			500Pta	200Pta	100Pta	50Pta	25Pta	-	-	200Pta	-	50Pta old	25Pta old	-	
Spain	Coin Controls C220 Parallel	OFF	OFF	ON	ON			100Pta	50Pta new	-	25Pta new	-	50Pta old	-	25Pta old					
Portugal Euro	Parallel	ON	OFF	ON	ON			200Es €1	100Es 50¢	50Es	-	-	-	-						
	TBA					OFF		TBA					<b>Please Note</b> The credit board automatically sets the validator for parallel and binary operation through an output on pin 8 of the 17 way pinstrip. For the feature to work it is necessary for the validator interconnecting cable to include at wire at this position							
						ON		TBA												
	Channels					OFF		Direct Mode												
						ON		2 channel Mode												

Note: These switch settings are under constant review and may change due to world currency updates.

- Set SW 1 according to the option settings found in the relevant Price of Play Settings Table on the following pages.
- For Germany (DM), France (Fr) & Switzerland (SFr), use the appropriate existing setting shown above (from another country) that matches the coin ratios programmed into your coin mech.
- Set SW 3 on the VTS/Excel board as shown in the table above corresponding to the country required.

## 22.2. PRICE OF PLAY SETTINGS UK

	Price	Bonus			DIL Switch 1				
					Switch 1	Switch 2	Switch 3	Switch 4	Switch 5
1	10p	No Bonus			OFF	OFF	OFF	OFF	OFF
2	10p	6 = 50p			<b>ON</b>	OFF	OFF	OFF	OFF
3	20p	No Bonus			OFF	<b>ON</b>	OFF	OFF	OFF
4	20p	3 = 50p	6 = £1	12 = £2	<b>ON</b>	<b>ON</b>	OFF	OFF	OFF
5	30p	No Bonus			OFF	OFF	<b>ON</b>	OFF	OFF
6	30p	1.66 = 50p	4 = £1	8 = £2	<b>ON</b>	OFF	<b>ON</b>	OFF	OFF
7	30p	2 = 50p	4 = £1		OFF	<b>ON</b>	<b>ON</b>	OFF	OFF
8	30p	AMLD *	3 = £1	6 = £2	<b>ON</b>	<b>ON</b>	<b>ON</b>	OFF	OFF
9	40p	No Bonus			OFF	OFF	OFF	<b>ON</b>	OFF
10	40p	1.25 = 50p	3 = £1	6 = £2	<b>ON</b>	OFF	OFF	<b>ON</b>	OFF
11	50p	No Bonus			OFF	<b>ON</b>	OFF	<b>ON</b>	OFF
12	50p		3 = £1	6 = £2	<b>ON</b>	<b>ON</b>	OFF	<b>ON</b>	OFF
13	50p		2 = £1	5 = £2	OFF	OFF	<b>ON</b>	<b>ON</b>	OFF
14	60p	No Bonus			<b>ON</b>	OFF	<b>ON</b>	<b>ON</b>	OFF
15	60p		2 = £1	4 = £2	OFF	<b>ON</b>	<b>ON</b>	<b>ON</b>	OFF
16	80p	No Bonus			<b>ON</b>	<b>ON</b>	<b>ON</b>	<b>ON</b>	OFF
17	80p	1.25 = £1	2 = £1.50	2.5 = £2	OFF	OFF	OFF	OFF	<b>ON</b>
18	£1	No Bonus			<b>ON</b>	OFF	OFF	OFF	<b>ON</b>
19	£1		3 = £2		OFF	<b>ON</b>	OFF	OFF	<b>ON</b>
20	£1		2 = £2	5 = £4	<b>ON</b>	<b>ON</b>	OFF	OFF	<b>ON</b>
21	£1.50	No Bonus			OFF	OFF	<b>ON</b>	OFF	<b>ON</b>
22	£1.50		2 = £2		<b>ON</b>	OFF	<b>ON</b>	OFF	<b>ON</b>
23	£2	No Bonus			OFF	<b>ON</b>	<b>ON</b>	OFF	<b>ON</b>
24	£2			3 = £5	<b>ON</b>	<b>ON</b>	<b>ON</b>	OFF	<b>ON</b>
25	£3	No Bonus			OFF	OFF	OFF	<b>ON</b>	<b>ON</b>
26	£3			2 = £5	<b>ON</b>	OFF	OFF	<b>ON</b>	<b>ON</b>
27	£5	No Bonus			OFF	<b>ON</b>	OFF	<b>ON</b>	<b>ON</b>
28	£5			3 = £10	<b>ON</b>	<b>ON</b>	OFF	<b>ON</b>	<b>ON</b>
29	£7.50	No Bonus			OFF	OFF	<b>ON</b>	<b>ON</b>	<b>ON</b>
30	£7.50			2 = £10	<b>ON</b>	OFF	<b>ON</b>	<b>ON</b>	<b>ON</b>
31	£10	No Bonus			OFF	<b>ON</b>	<b>ON</b>	<b>ON</b>	<b>ON</b>
32	Free Play				<b>ON</b>	<b>ON</b>	<b>ON</b>	<b>ON</b>	<b>ON</b>



### 22.3. PRICE OF PLAY SETTINGS EURO

	Price	Bonus			DIL Switch 1				
					Switch 1	Switch 2	Switch 3	Switch 4	Switch 5
1	10¢	No Bonus			OFF	OFF	OFF	OFF	OFF
2	10¢	6 = 50¢			<b>ON</b>	OFF	OFF	OFF	OFF
3	20¢	No Bonus			OFF	<b>ON</b>	OFF	OFF	OFF
4	20¢	3 = 50¢	6 = €1	12 = €2	<b>ON</b>	<b>ON</b>	OFF	OFF	OFF
5	30¢	No Bonus			OFF	OFF	<b>ON</b>	OFF	OFF
6	30¢	1.66 = 50¢	4 = €1	8 = €2	<b>ON</b>	OFF	<b>ON</b>	OFF	OFF
7	30¢	2 = 50¢	4 = €1		OFF	<b>ON</b>	<b>ON</b>	OFF	OFF
8	30¢	AMLD *	3 = €1	6 = €2	<b>ON</b>	<b>ON</b>	<b>ON</b>	OFF	OFF
9	40¢	No Bonus			OFF	OFF	OFF	<b>ON</b>	OFF
10	40¢	1.25 = 50¢	3 = €1	6 = €2	<b>ON</b>	OFF	OFF	<b>ON</b>	OFF
11	50¢	No Bonus			OFF	<b>ON</b>	OFF	<b>ON</b>	OFF
12	50¢		3 = €1	6 = €2	<b>ON</b>	<b>ON</b>	OFF	<b>ON</b>	OFF
13	50¢		2 = €1	5 = €2	OFF	OFF	<b>ON</b>	<b>ON</b>	OFF
14	60¢	No Bonus			<b>ON</b>	OFF	<b>ON</b>	<b>ON</b>	OFF
15	60¢		2 = €1	4 = €2	OFF	<b>ON</b>	<b>ON</b>	<b>ON</b>	OFF
16	80¢	No Bonus			<b>ON</b>	<b>ON</b>	<b>ON</b>	<b>ON</b>	OFF
17	80¢	1.25 = £1	2 = €1.50	2.5 = €2	OFF	OFF	OFF	OFF	<b>ON</b>
18	€1	No Bonus			<b>ON</b>	OFF	OFF	OFF	<b>ON</b>
19	€1		3 = €2		OFF	<b>ON</b>	OFF	OFF	<b>ON</b>
20	€1		2 = €2	5 = €4	<b>ON</b>	<b>ON</b>	OFF	OFF	<b>ON</b>
21	€1.50	No Bonus			OFF	OFF	<b>ON</b>	OFF	<b>ON</b>
22	€1.50		2 = €2		<b>ON</b>	<b>OFF</b>	<b>ON</b>	OFF	<b>ON</b>
23	€2	No Bonus			OFF	<b>ON</b>	<b>ON</b>	OFF	<b>ON</b>
24	€2			3 = €5	<b>ON</b>	<b>ON</b>	<b>ON</b>	OFF	<b>ON</b>
25	€3	No Bonus			OFF	OFF	OFF	<b>ON</b>	<b>ON</b>
26	€3			2 = €5	<b>ON</b>	OFF	OFF	<b>ON</b>	<b>ON</b>
27	€5	No Bonus			OFF	<b>ON</b>	OFF	<b>ON</b>	<b>ON</b>
28	€5			3 = €10	<b>ON</b>	<b>ON</b>	OFF	<b>ON</b>	<b>ON</b>
29	€7.50	No Bonus			OFF	OFF	<b>ON</b>	<b>ON</b>	<b>ON</b>
30	€7.50			2 = €10	<b>ON</b>	OFF	<b>ON</b>	<b>ON</b>	<b>ON</b>
31	€10	No Bonus			OFF	<b>ON</b>	<b>ON</b>	<b>ON</b>	<b>ON</b>
32	Free Play				<b>ON</b>	<b>ON</b>	<b>ON</b>	<b>ON</b>	<b>ON</b>



23. DESIGNED RELATED PARTS

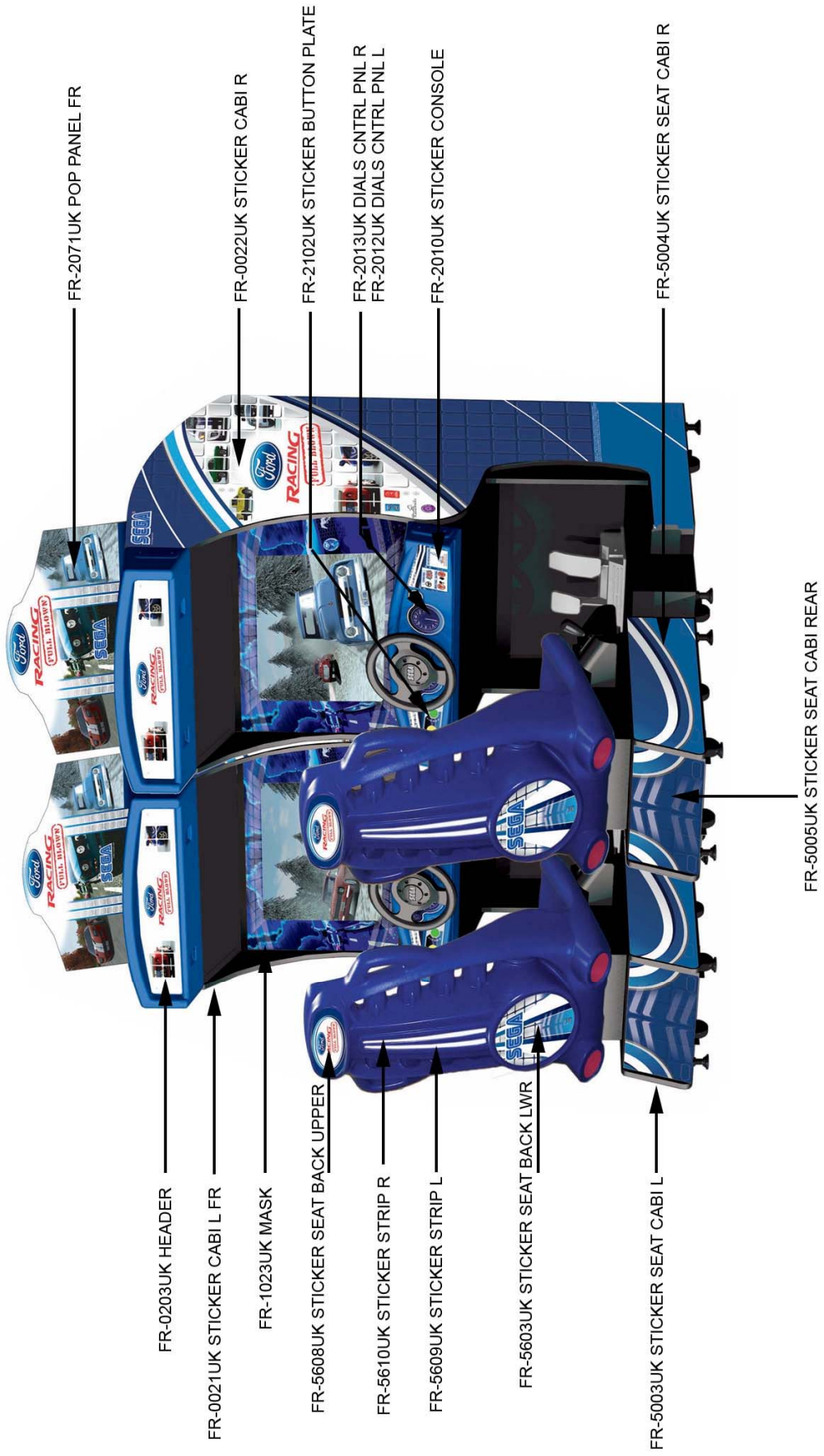

24. PARTS LIST

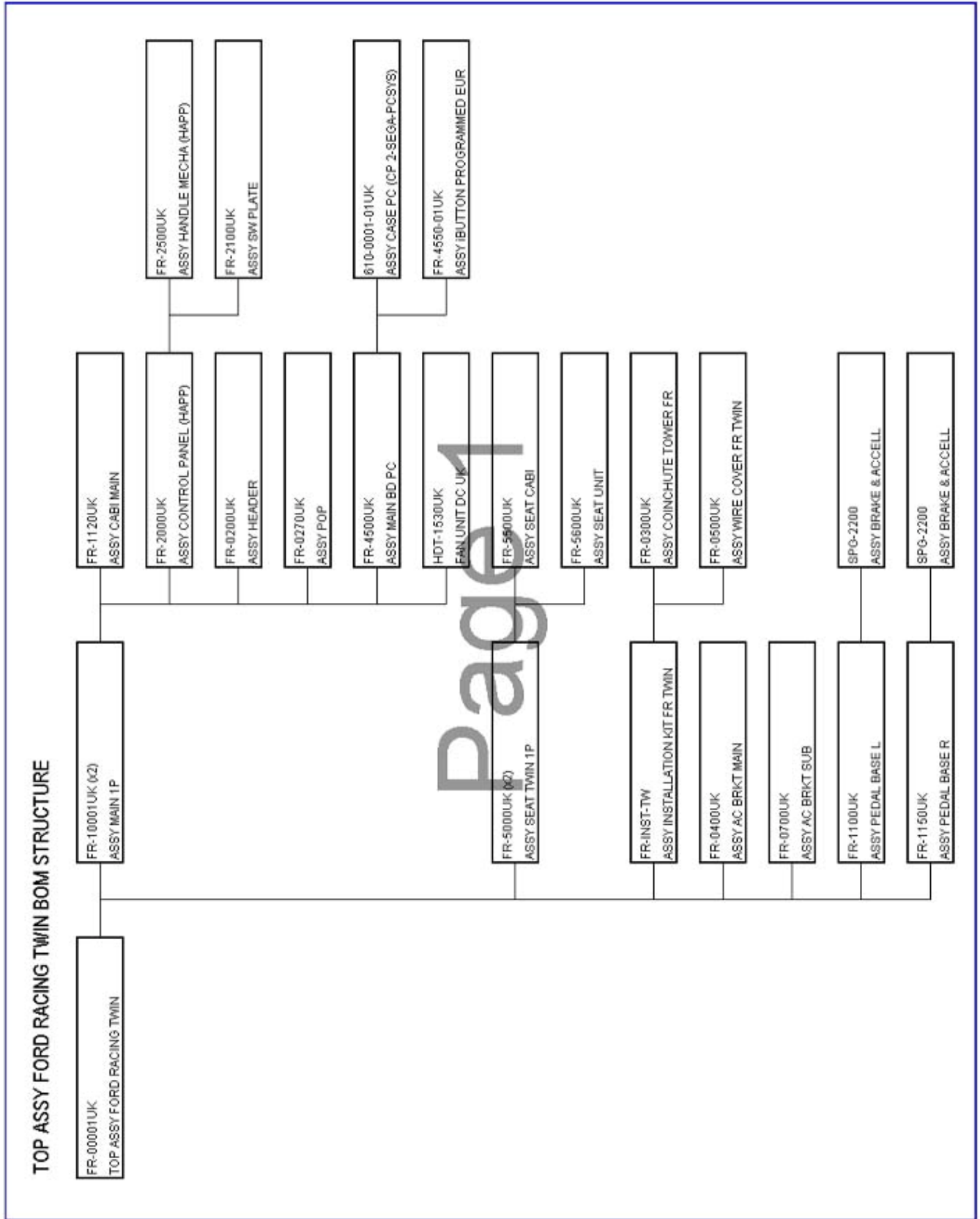

24.1. TOP ASSY FORD RACING TWIN – FR00001UK

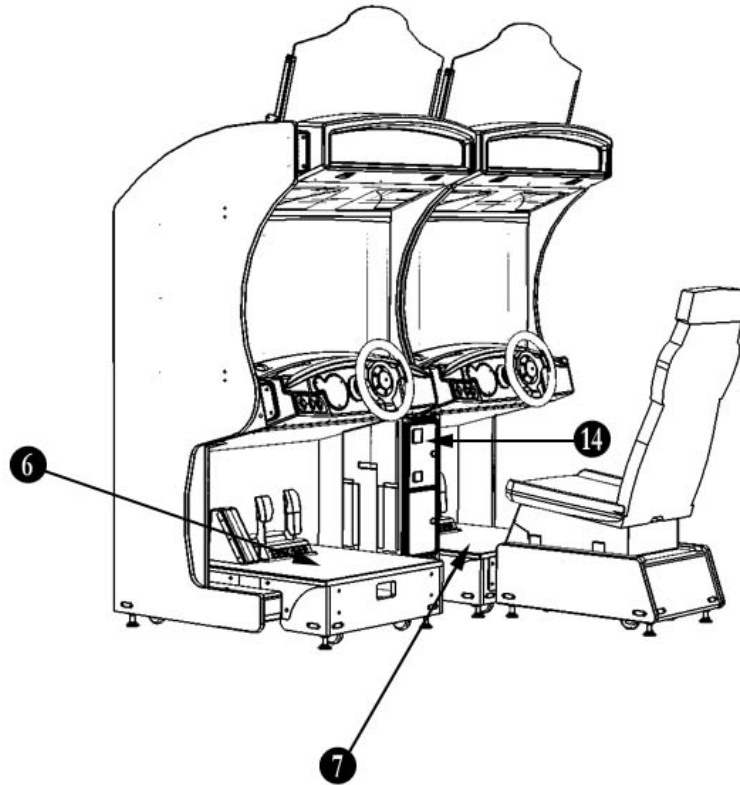
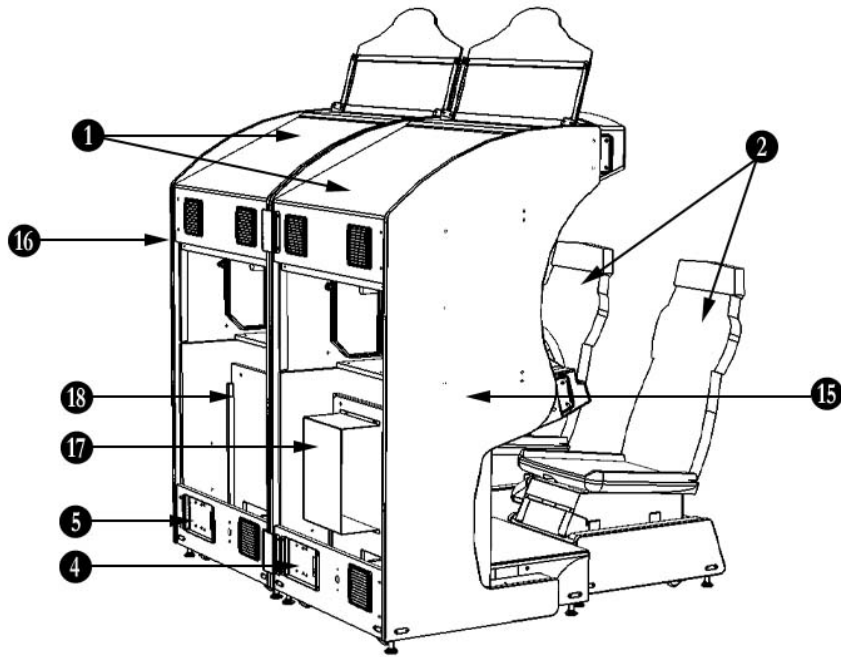

SEQ	PT NUMBER	DESCRIPTION	QTY
1	FR-10001UK	ASSY MAIN 1P	2
2	FR-5000UK	ASSY SEAT TWIN 1P	2
4	FR-0400UK	ASSY AC BRKT MAIN	1
5	FR-0700UK	ASSY AC BRKT SUB	1
6	FR-1100UK	ASSY PEDAL BASE L	1
7	FR-1150UK	ASSY PEDAL BASE R	1
14	FR-0300UK	ASSY COINCHUTE TOWER	1
15	FR-0021UK	STICKER CABI L FR	1
16	FR-0022UK	STICKER CABI R FR	1
17	FR-4500UK	ASSY MAIN BD PC MASTER	1
18	FR-4600UK	ASSY MAIN BD PC SLAVE	1

24.2. ASSY MAIN 1P – FR-10001UK

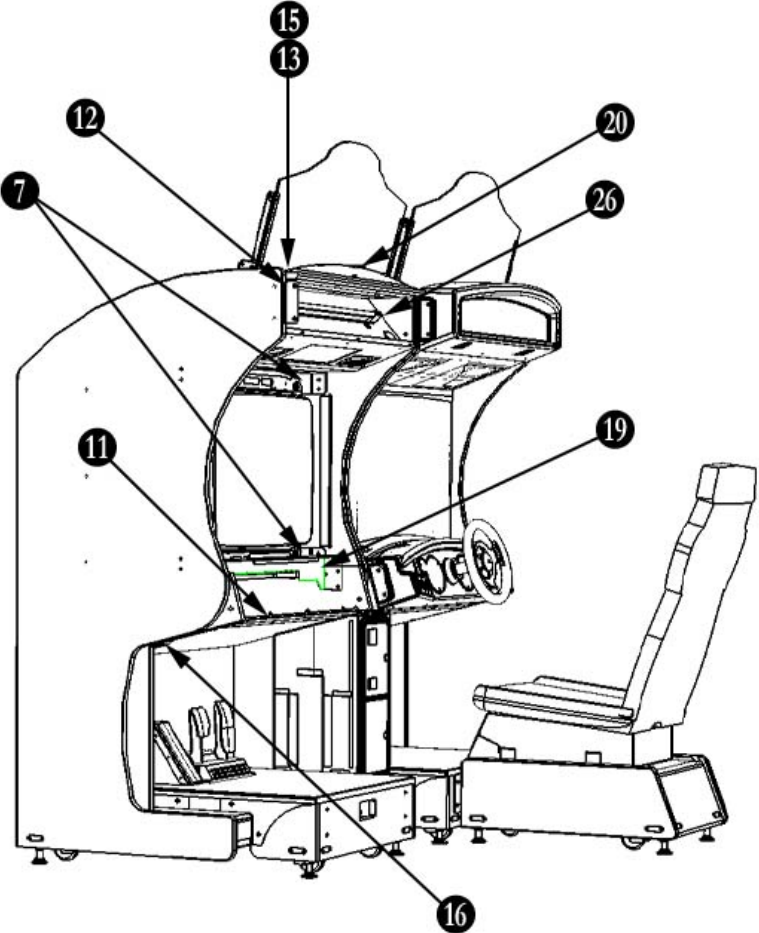
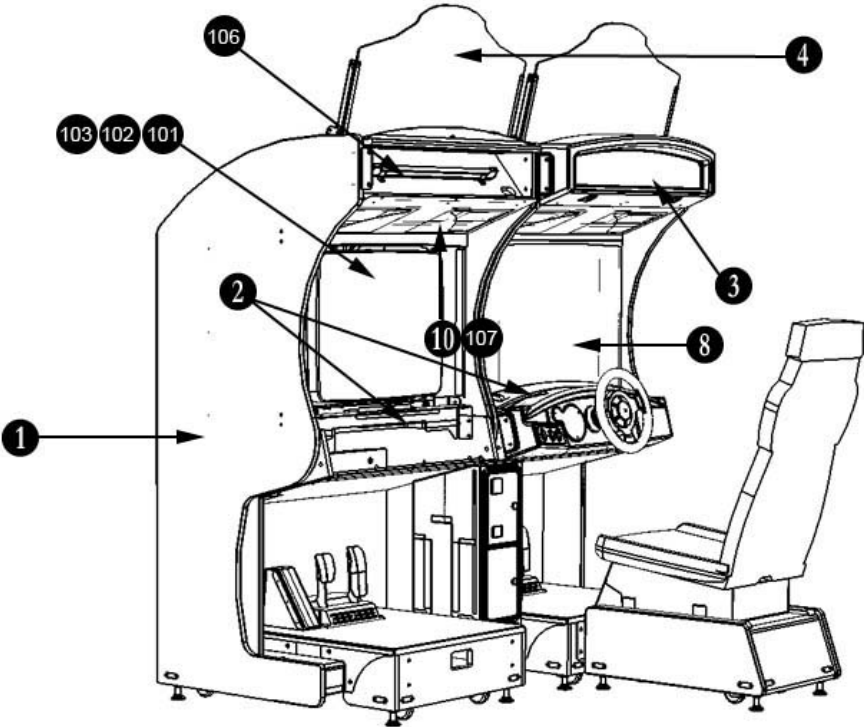

Continues overleaf

SEQ	PT NUMBER	DESCRIPTION	QTY
1	FR-1120UKI	FR MAIN CABI	2
2	FR-2000UK	ASSY CONTROL PANEL	2
3	FR-0200UK	ASSY HEADER	2
4	FR-0270UK	ASSY POP	2
7	FR-1022UK	MONITOR SUPPORT	2
8	FR-1023UK	MASK	2
10	FR-1025UK	SPEAKER PNL	2
11	FR-1026UK	BKT SUPPORT CNTRL PNL LWR	2
12	FR-1027UK	BRKT SUPP HEADER COVER	2
13	FR-1028UK	PLATE BACK HEADER COVER	2
15	FR-1132UK	PLATE UP LIGHT	2
16	HDF-1081UK	ADJUST PANEL	2
20	FR-1030UK	BRKT SUPPORT HEADER	2
26	HDF-0457UK	BRKT FL TUBE HOLDER	6
101	200-5949-PFX	ASSY 29" PFX TYPE 240V	2
102	280-6643	BUSH FOR TV PF	8
103	280-5113	COLLAR FOR NANA0 MONITOR	8
106	390-7001-20W-UK	ASSY FL 20W BBI C24 T4	2
107	130-365-564UK	SPKR 15W 40 OHM XF	4

24.3. ASSY CONTROL PANEL – FR-2000UK

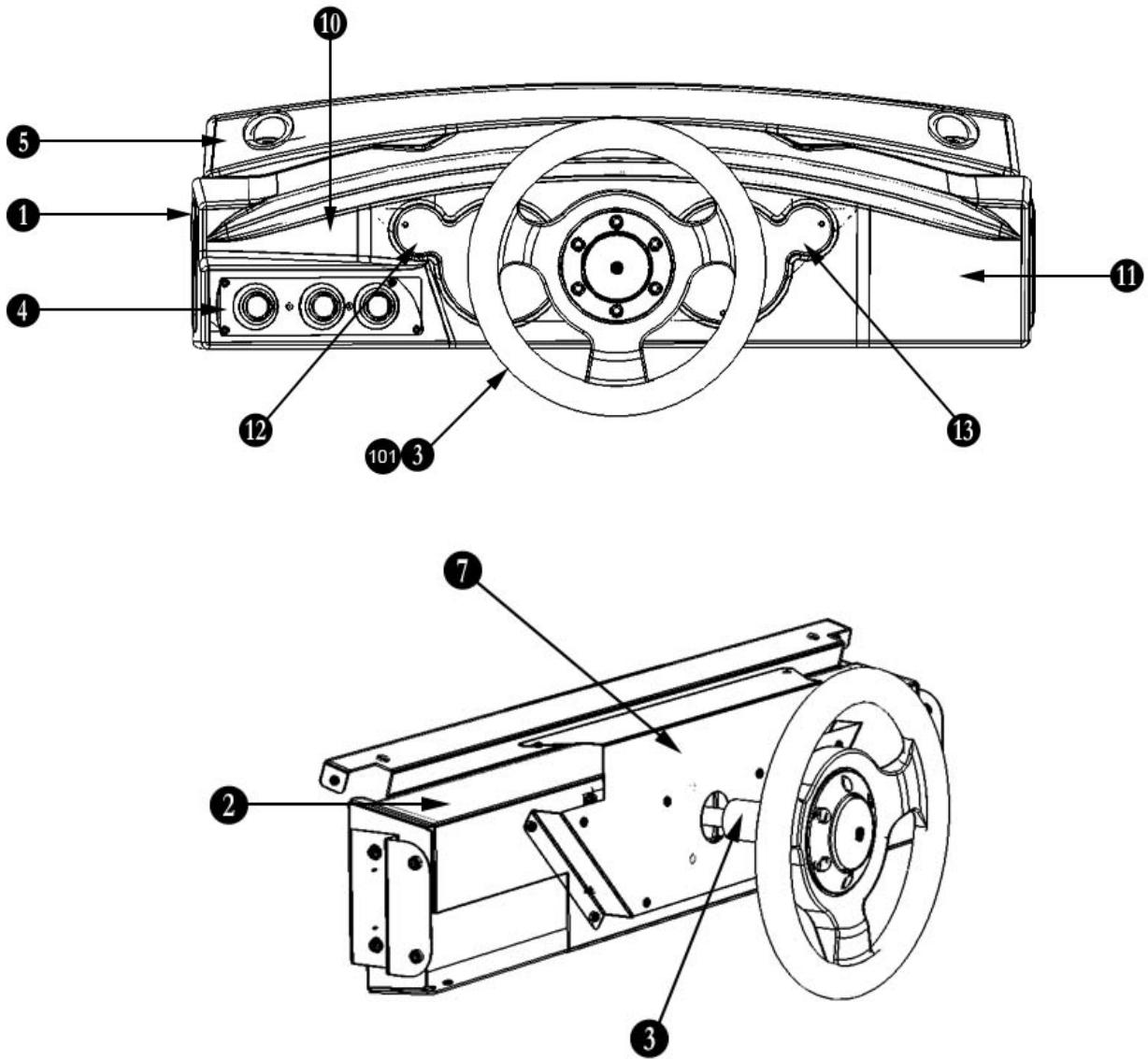

SEQ	PT NUMBER	DESCRIPTION	QTY
1	FR-2001UK	CONTROL PANEL COVER	1
2	FR-2002UK	CONTROL PANEL BRKT TWIN	1
3	FR-2003UK	HANDLE COLLAR	1
4	FR-2100UK	ASSY SW PLATE	1
5	FR-2004UK	FORMING CNTRL PAN CLOSURE	1
7	FR-2006UK	BRKT FRONT CNTRL PNL	1
10	FR-2010UK	STICKER CONSOLE	1
11	422-FRIPI-UK	PLAY INSTRUCTION FR TWIN	1
12	FR-2012UK	DIALS CNTRL PAN L	1
13	FR-2013UK	DIALS CNTRL PAN R	1
101	FR-2500UK	ASSY MECHA HAPP 50-0102-08	1

# 24.4. ASSY HANDLE MECHA – FR-2500UK

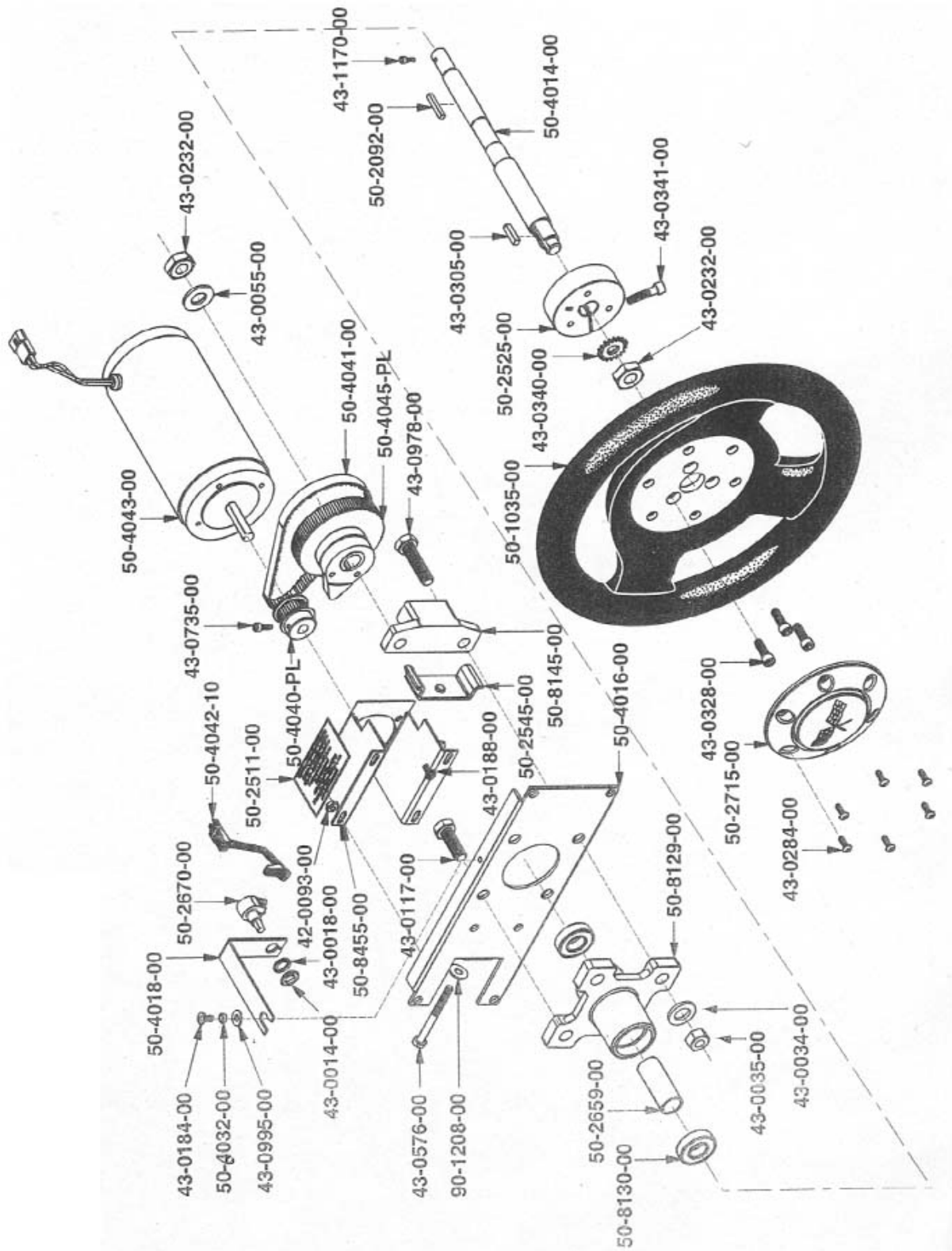

## 24.5. ASSY SW PLATE – FR-2100UK

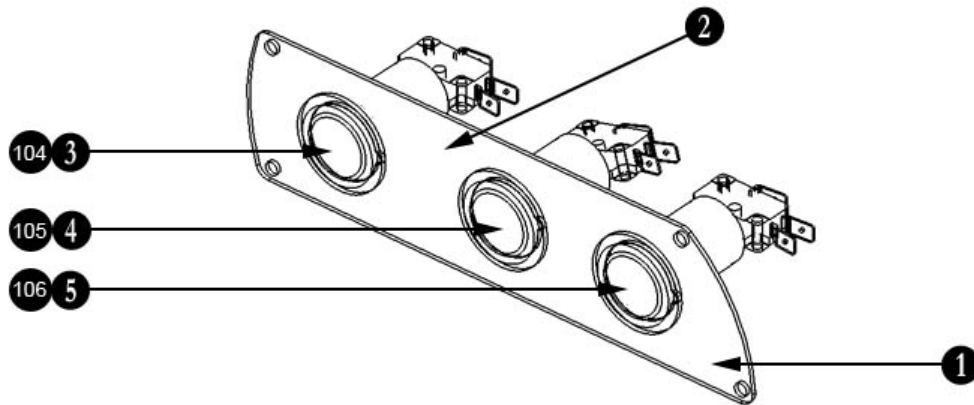

SEQ	PT NUMBER	DESCRIPTION	QTY
1	FR-2101UK	BUTTON PLATE	1
2	FR-2102UK	STICKER BUTTON PLATE	1
3	509-6001-Y	BTN RND 12V YELLOW 22-2060-4LP	1
4	509-6001-B	BTN RND 12V BLUE 22-2060-6BBLP	1
5	509-6001-G	BTN RND 12V GRN 22-2060-5LP	1
104	LT1051	LED CLUSTER YEL 161-12103-4	1
105	LT1052	LED CLUSTER GRN 161-12103-5	1
103	LT1053	LED CLUSTER BLU 161-12103-X	1



24.6. ASSY HEADER – FR-0200UK

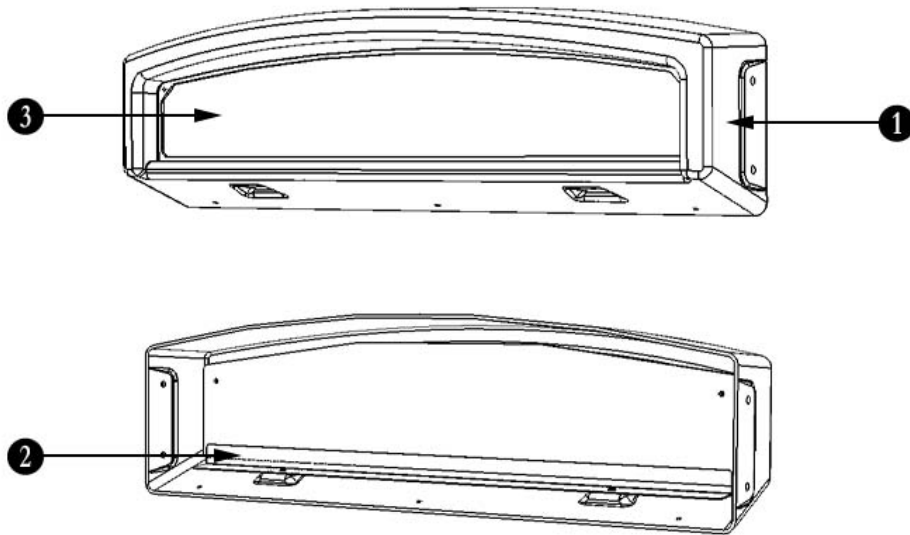

SEQ	PT NUMBER	DESCRIPTION	QTY
1	FR-0201UK	HEADER COVER	1
2	FR-0202UK	HEADER SUPPORT BRKT	1
3	FR-0203UK	HEADER	1

24.7. ASSY POP – FR-0270UK

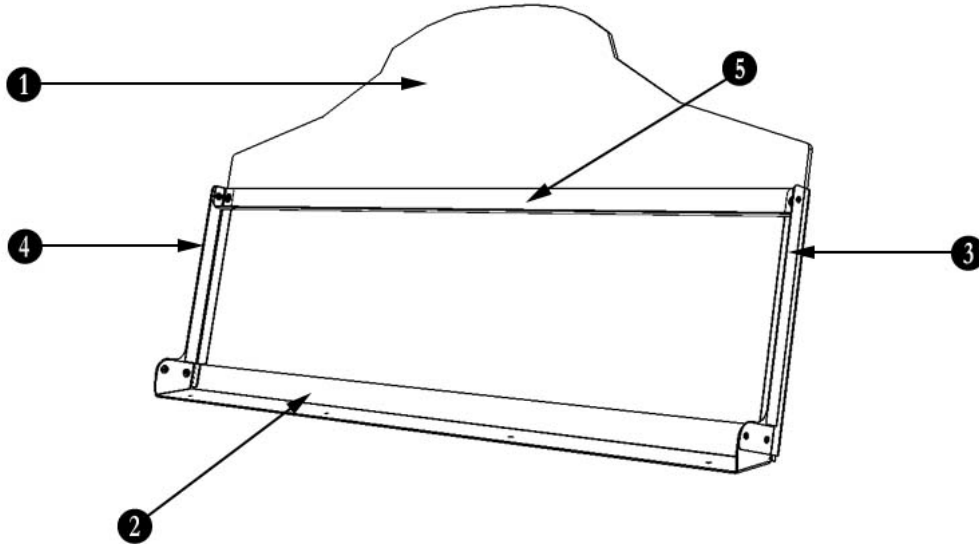

SEQ	PT NUMBER	DESCRIPTION	QTY
1	FR-2071UK	POP PANEL FR	1
2	FR-0272UK	BRKT SUPP POP LOWER	1
3	FR-0273UK	BRKT SUPP STRUT L	1
4	FR-0274UK	BRKT SUPP STRUT R	1
5	FR-0275UK	BRKT CROSS BRACE POP	1

24.8. ASSY FAN UNIT DC – HDT-1530UK

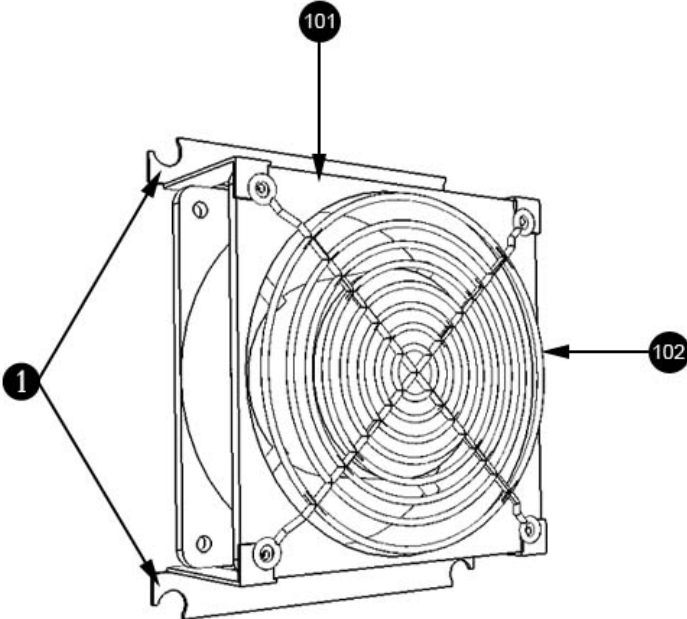

SEQ	PT NUMBER	DESCRIPTION	QTY
1	105-5340-01	FAN BKT LONG	2
101	EC814500	12V DC FAN 120MM KD1212PMS3-6A	1
102	FN1012	FAN GUARD METAL 120MM FG-12	1
301	HDF-60004UK	WIRE HARNESS FAN LINK (NOT SHOWN)	1

## 24.9. ASSY SEAT TWIN 1P – FR-5000UK

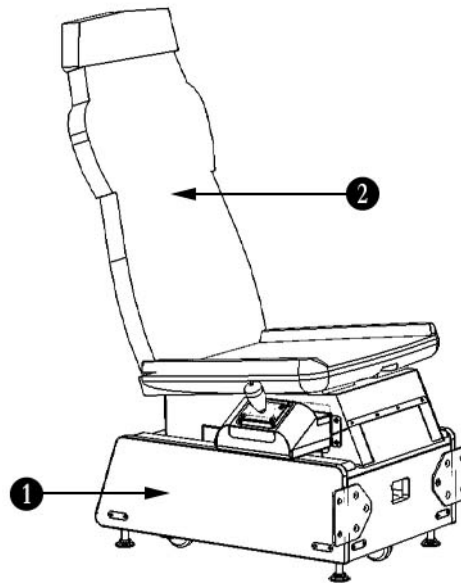

SEQ	PT NUMBER	DESCRIPTION	QTY
1	FR-5500UK	ASSY SEAT CABI	1
2	FR-5600UK	ASSY SEAT UNIT	1

## 24.10. ASSY SEAT CABI – FR-5500UK

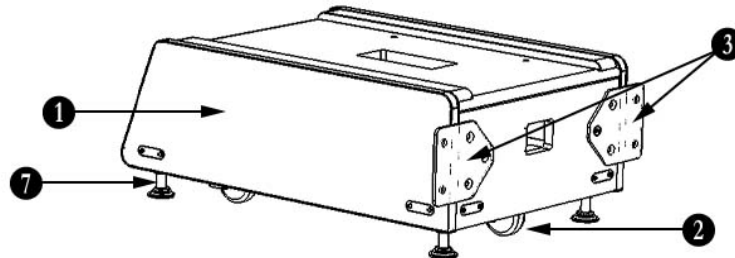

SEQ	PT NUMBER	DESCRIPTION	QTY
1	FR-5501UK	WOODEN SEAT CABI	1
2	MA1019	CASTER 75	3
3	FR-5505UK	JOINT PLATE	2
7	601-5699UK	LEG ADJUSTER M16X100 1L/NUT	4

24.11. ASSY SEAT UNIT – FR-5600UK

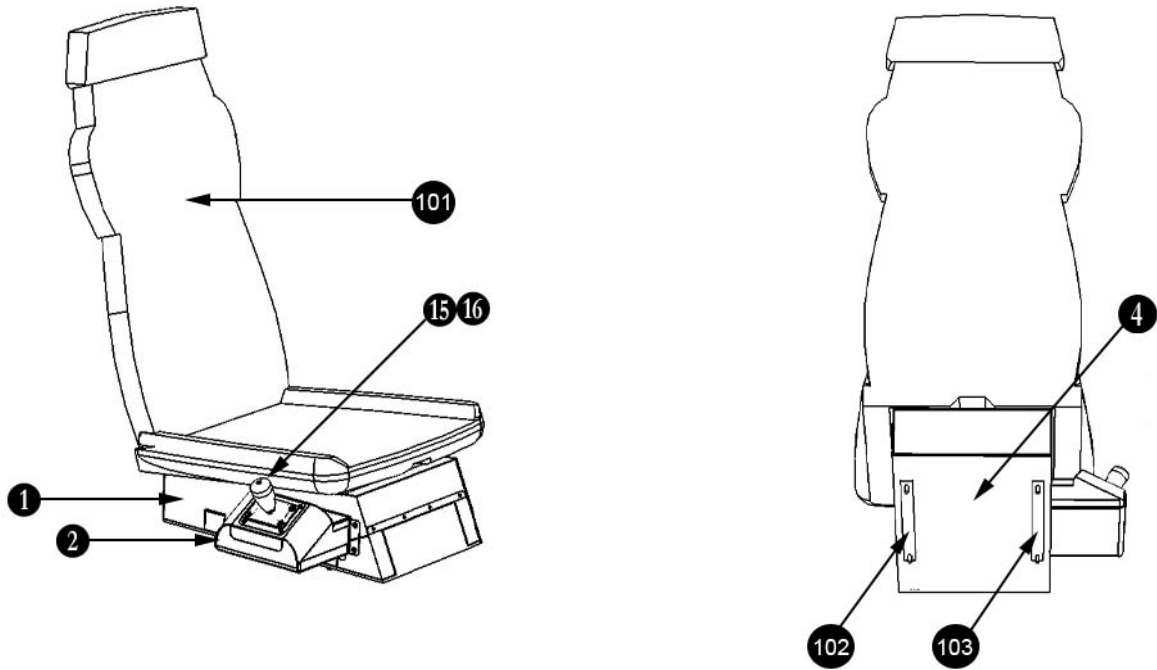

SEQ	PT NUMBER	DESCRIPTION	QTY
1	FR-5601UK	SEAT BASE	1
2	FR-5602UK	SHIFT ENCLOSURE	1
4	FR-5604UK	SEAT ADAPTOR PLATE	1
15	610-0408-91	UP/DOWN SHIFTER AL	1
16	RND-0039	PLATE U/D SHIFT MTNG	1
101	RND-0063-01	SEAT MIDWAY 04-12452 RAL5005	1
102	601-9059-91	SEAT RAIL L	1
103	601-9060-91	SEAT RAIL R	1

24.12. ASSY AC BRKT MAIN – FR-0400UK

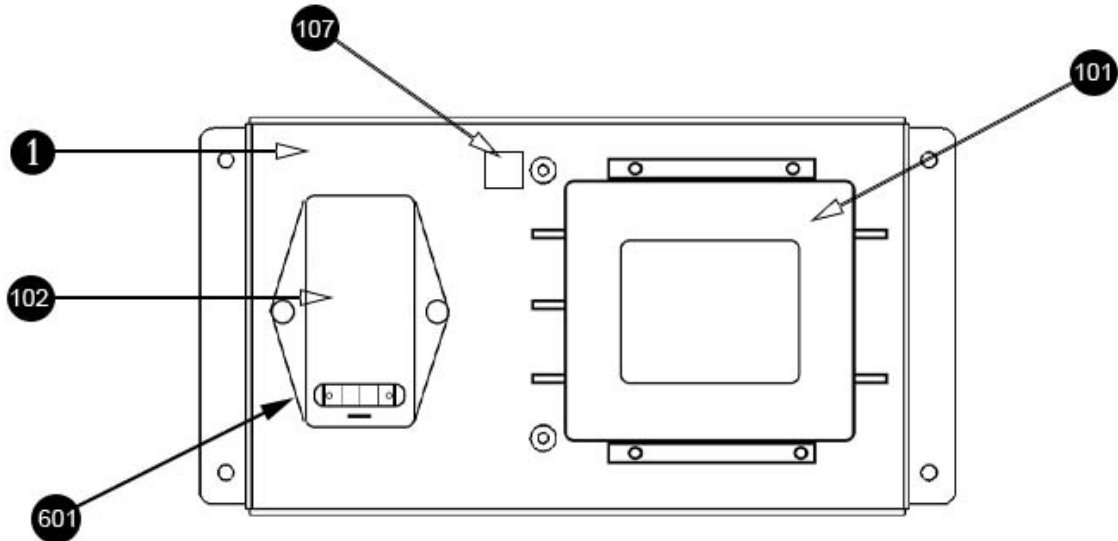

SEQ	PT NUMBER	DESCRIPTION	QTY
1	HDF-0661UK	BRKT AC HDF	1
101	EP1382	FILTER SCHAFFNER FN682-10/06	1
102	EP1387	IEC INLET & SW BZV01/Z0000/70	1
107	LB1096	STICKER PROTECTIVE EARTH	1
301	FR-60011UK	WIRE HARNESS AC BRKT FR (NOT SHOWN)	1
601	514-5078-10000	FUSE 5X20 CERAMIC SB 10A	1

24.13. ASSY AC BKT SUB – FR-0700UK

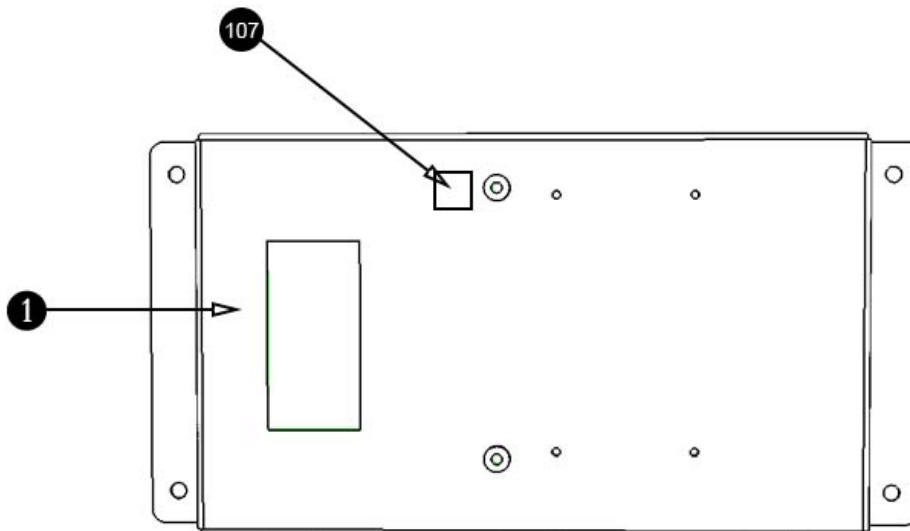

SEQ	PT NUMBER	DESCRIPTION	QTY
1	FR-0701UKUK	BRKT AC FR	1
107	LB1096	STICKER PROTECTIVE EARTH	1
202	050-F00400	NUT M4 FLG SER PAS	1

24.14. ASSY PEDAL BASE L – FR-1100UK

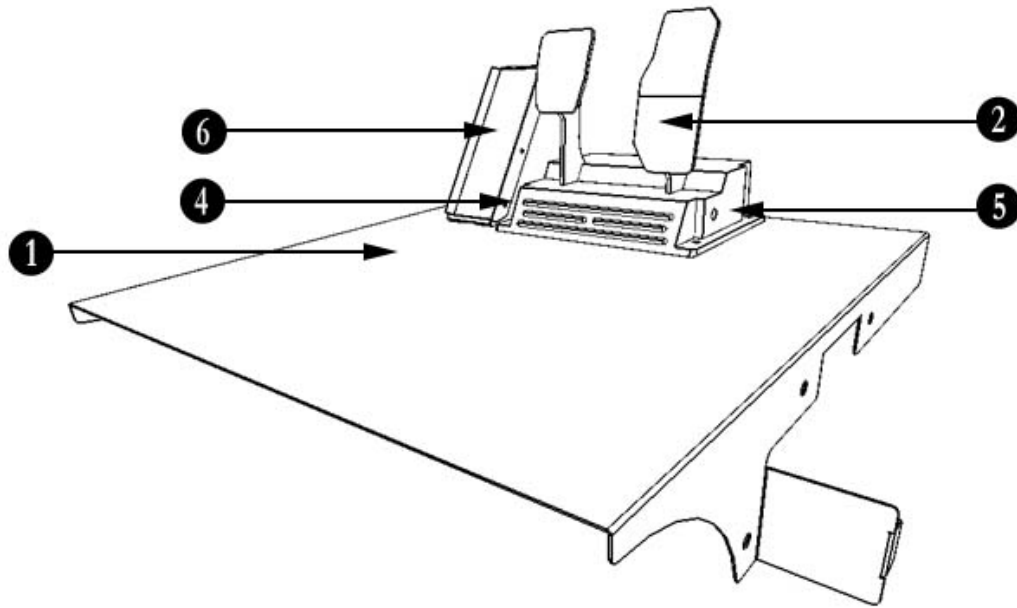

SEQ	PT NUMBER	DESCRIPTION	QTY
1	FR-1101UK	BASE PLATE L	1
2	SPG-2200	ASSY ACCEL & BRAKE	1
4	FR-2222UK	ANTI FINGER TRAP PLATE L	1
5	FR-2223UK	ANTI FINGER TRAP PLATE R	1
6	FRI-2201	FOOT REST FRI	1

24.15. ASSY PEDAL BASE R – FR-1150UK

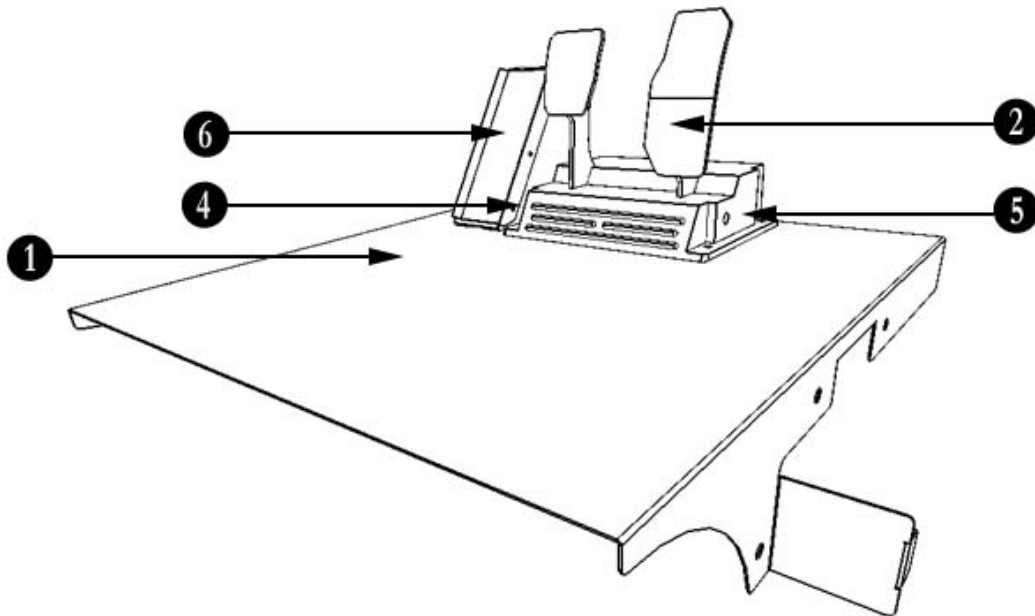

SEQ	PT NUMBER	DESCRIPTION	QTY
1	FR-1151UK	BASE PLATE R	1
2	SPG-2200	ASSY ACCEL & BRAKE	1
4	FR-2222UK	ANTI FINGER TRAP PLATE L	1
5	FR-2223UK	ANTI FINGER TRAP PLATE R	1
6	FRI-2201	FOOT REST FRI	1

24.16. ASSY BRAKE & ACCEL – SPG-2200

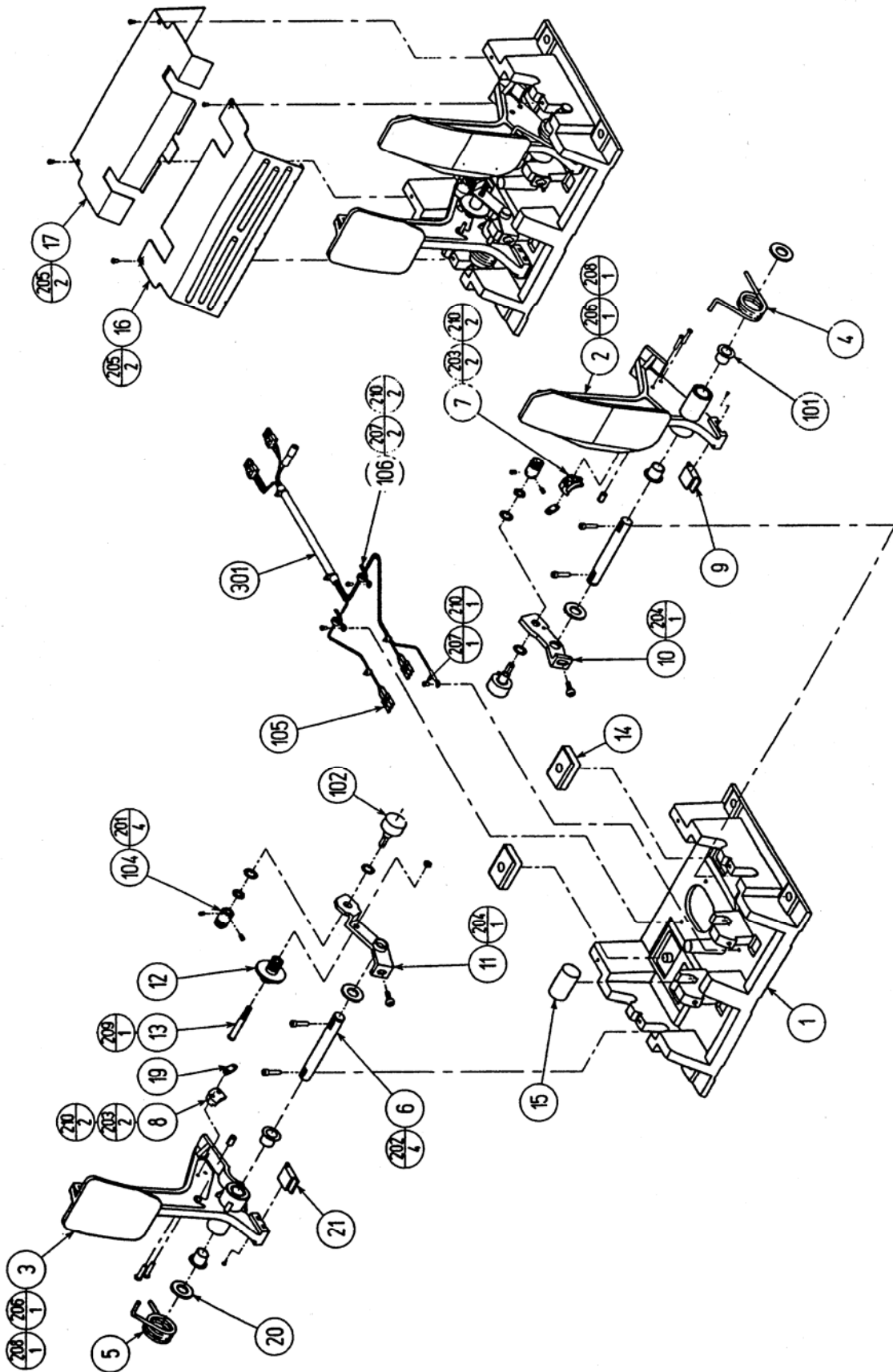

ITEM NO.	PART NO.	DESCRIPTION
1	SPG-2201	BASE
2	SPG-2202	ACCEL PEDAL
3	SPG-2203	BRAKE PEDAL
4	SPG-2204	ACCEL SPRING
5	SPG-2205	BRAKE SPRING
6	SPG-2206	SHAFT
7	SPG-2207	ACCEL GEAR
8	SPG-2208	BRAKE GEAR
9	SPG-2209	NEUTRAL STOPPER
10	SPG-2210	VR PLATE ACCEL
11	SPG-2211	VR PLATE BRAKE
12	SPG-2212	AMPL GEAR
13	SPG-2213	GEAR SHAFT
14	SPG-2214	STOPPER
15	SPG-2215	RUBBER CUSHION
16	SPG-2216	COVER
17	SPG-2217	VR COVER
19	SPG-2219	GEAR STAY
20	SPG-2220	WSHR
21	SPG-2221	NEUTRAL STOPPER D
101	100-5263	BEARING 12
102	220-5484	VOL CONT B-5K OHM
	220-5373	VOL CONT B-5K
104	601-7944	GEAR 15
105	310-5029-F15	SUMITUBE F F 15MM
106	280-0419	HARNES LUG
201	028-A00304-P	SET SCR HEX SKT CUP P M3 × 4
202	020-000520-OZ	HEX SKT H CAP SCR BLK M5 × 20
203	000-P00420	M SCR PH M4 × 2
204	000-P00508-W	M SCR PH W/FS M5 × 8
205	000-T00408-OC	M SCR TH CRM M4 × 8
206	FAS-450005	SPR PIN BLK OZ 6 × 10
207	000-P00405	M SCR PH M4 × 5
208	FAS-000001	M SCR TH CRM M3 × 6
209	050-H00500	HEX NUT M5
210	060-F00400	FLT WSHR M4
301	600-6840	WIRE HARN ACCEL&BRAKE



## 24.17. ASSY MAIN BD PC MASTER – FR-4500UK

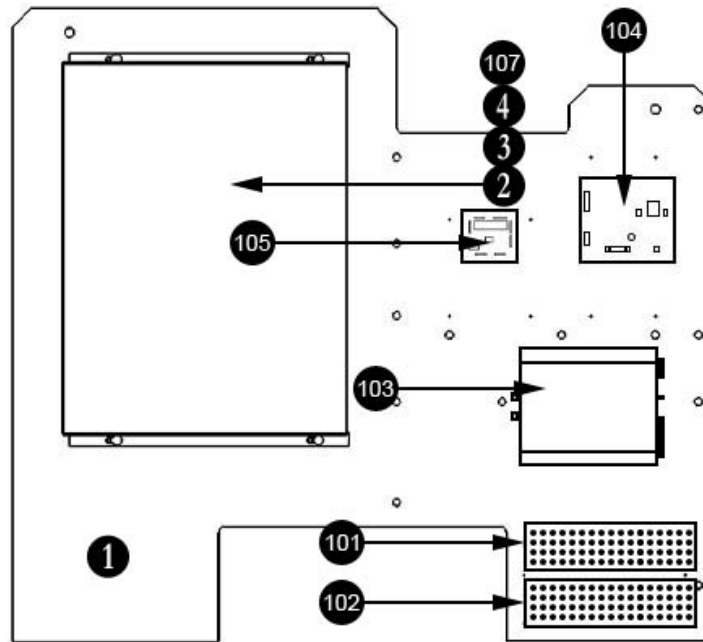

SEQ	PT NUMBER	DESCRIPTION	QTY
1	FR-4501UK	MAIN BD PC BASE	1
2	610-0001-01UK	ASSY CASE PC	1
3	LB1101	STICKER WARNING BATTERY	1
4	LB1111	STICKER PLEASE RECYCLE	1
101	400-0012-0100UK	POWER SUPPLY 12V 100W	1
102	400-0024-0100UK	POWER SUPPLY 24V 100W	1
103	838-CA-150	AUDIO AMP 15W	1
104	FR-838-001UK	MOTOR CONT ISO HAPP 50-2000-03	1
105	FR-838-002UK	UGCI DRIVING HAPP 95-0800-10	1
107	FR-4550-01UK	ASSY iBUTTON PROGRAMMED EUR	1

24.18. ASSY MAIN BD PC SLAVE – FR-4600UK

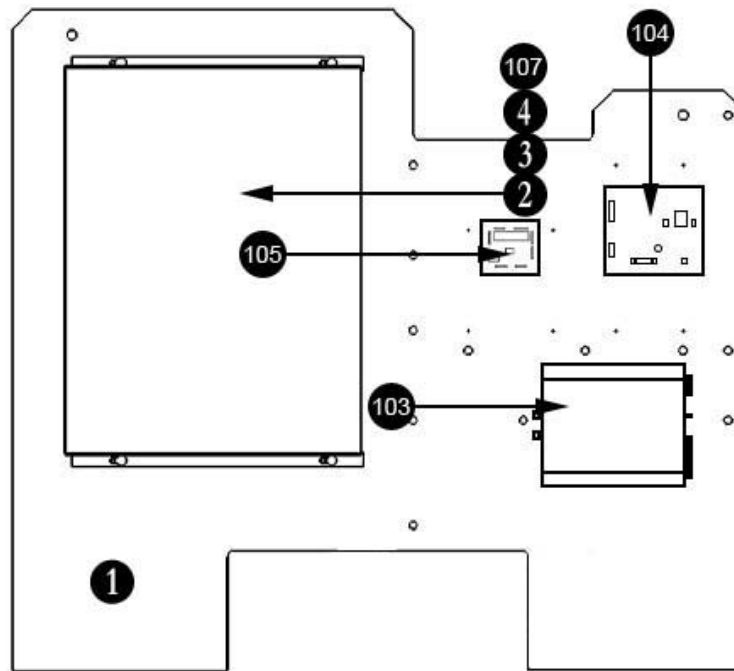

SEQ	PT NUMBER	DESCRIPTION	QTY
1	FR-4501UK	MAIN BD PC BASE	1
2	610-0001-01UK	ASSY CASE PC	1
3	LB1101	STICKER WARNING BATTERY	1
4	LB1111	STICKER PLEASE RECYCLE	1
103	838-CA-150	AUDIO AMP 15W	1
104	FR-838-001UK	MOTOR CONT ISO HAPP 50-2000-03	1
105	FR-838-002UK	UGCI DRIVING HAPP 95-0800-10	1
107	FR-4550-01UK	ASSY iBUTTON PROGRAMMED EUR	1

## 24.19. ASSY COINCHUTE TOWER

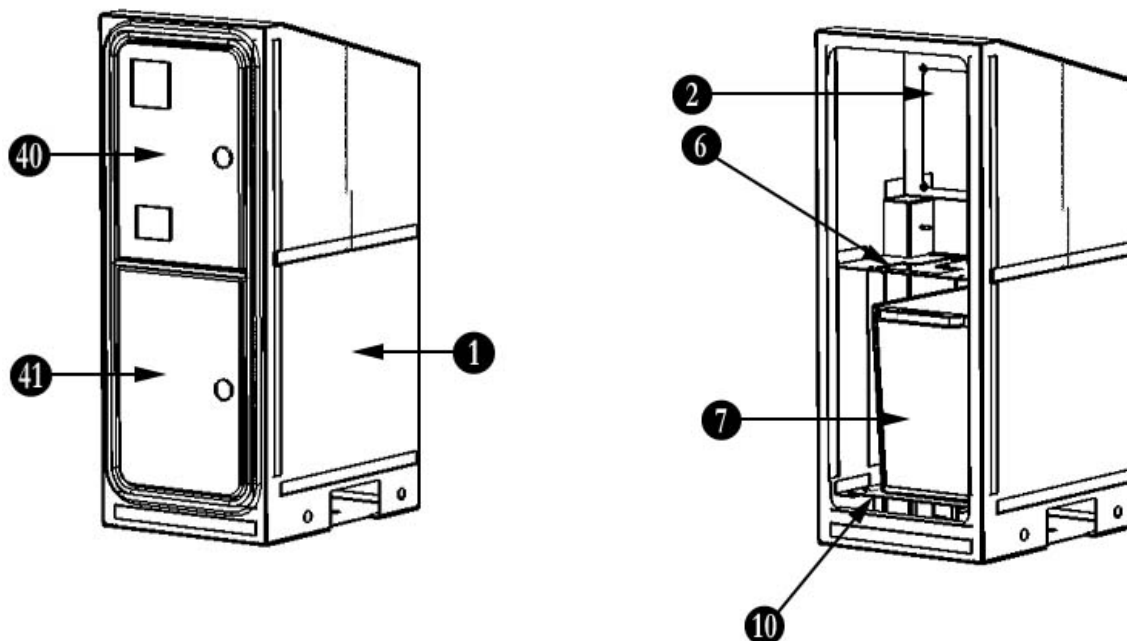

SEQ	PT NUMBER	DESCRIPTION	QTY
1	FR-0301UK	COIN CHUTE TOWER FR	1
2	VTS-FRI-T	VTS BOARD FRI TWIN	1
6	DUT-0302UK	COIN PATH PLATE	1
7	PP1087	CASHBOX FOR MINI DOOR	1
10	FR-0303UK	CCT FLOOR	1
40	220-5374-01	DOOR DFMD C120 UNIVERSAL	1
41	220-5725-05B	DOOR SINGLE MINI SECURITY BLK	1
42	220-5574-110UK	LOCK KEY DIFFERS 11MM (NOT SHOWN)	1

24.20. ASSY INSTALLATION KIT FR TWIN – FR-INST-TW

SEQ	PT NUMBER	DESCRIPTION	QTY
1	FR-0300UK	ASSY COINCHUTE TOWER	1
4	FR-0013UK	JOINT BRKT REAR	2
13	PK0388	INST KIT BOX FR TWIN	1
101	440-CS0186UK	STICKER C EPILEPSY MULTI	1
301	600-7269-0500UK	ASSY LAN CABLE 0500CM	1
401	420-5827-91UK	SERVICE MANUAL SANWA 31K	1
402	420-FRSM-02UK	SERVICE MANUAL FR TWIN	1
403	OS1019	SELF SEAL BAG	2
408	SAECE-142	DECLARATION OF CONFORMITY FR-T	1

## 25. APPENDIX A - ELECTRICAL SCHEMATIC

### 25.1. WIRE COLOURS

THE WIRE COLOUR CODE IS AS FOLLOWS:

A	PINK
B	SKY BLUE
C	BROWN
D	PURPLE
E	LIGHT GREEN

Wires other than those of any of the colours listed above will be displayed by 2 alphanumeric characters:

1	RED
2	BLUE
3	YELLOW
4	GREEN
5	WHITE
7	ORANGE
8	BLACK
9	GREY

If the right hand side numeral of the code is 0, then the wire will be of a single colour shown by the left hand side numeral (see the list above).

Note 1: If the right hand side alphanumeric is not 0, that particular wire has a spiral colour code. The left hand side character shows the base colour and the right hand side one, the spiral colour.

[Example] 51----- WHITE/RED = WHITE wire with RED stripes

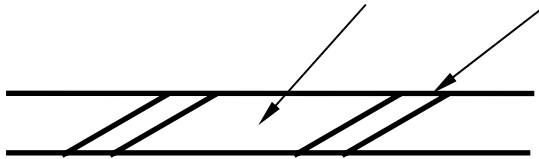

Note 2: The character following the wire colour code indicates the size of the wire.

K:	AWG18, UL1015
L:	AWG20, UL1007
None	AWG22, UL1007

### 25.2. ELECTRICAL SCHEMATIC

The following page(es) contains the electrical schematic for this machine.

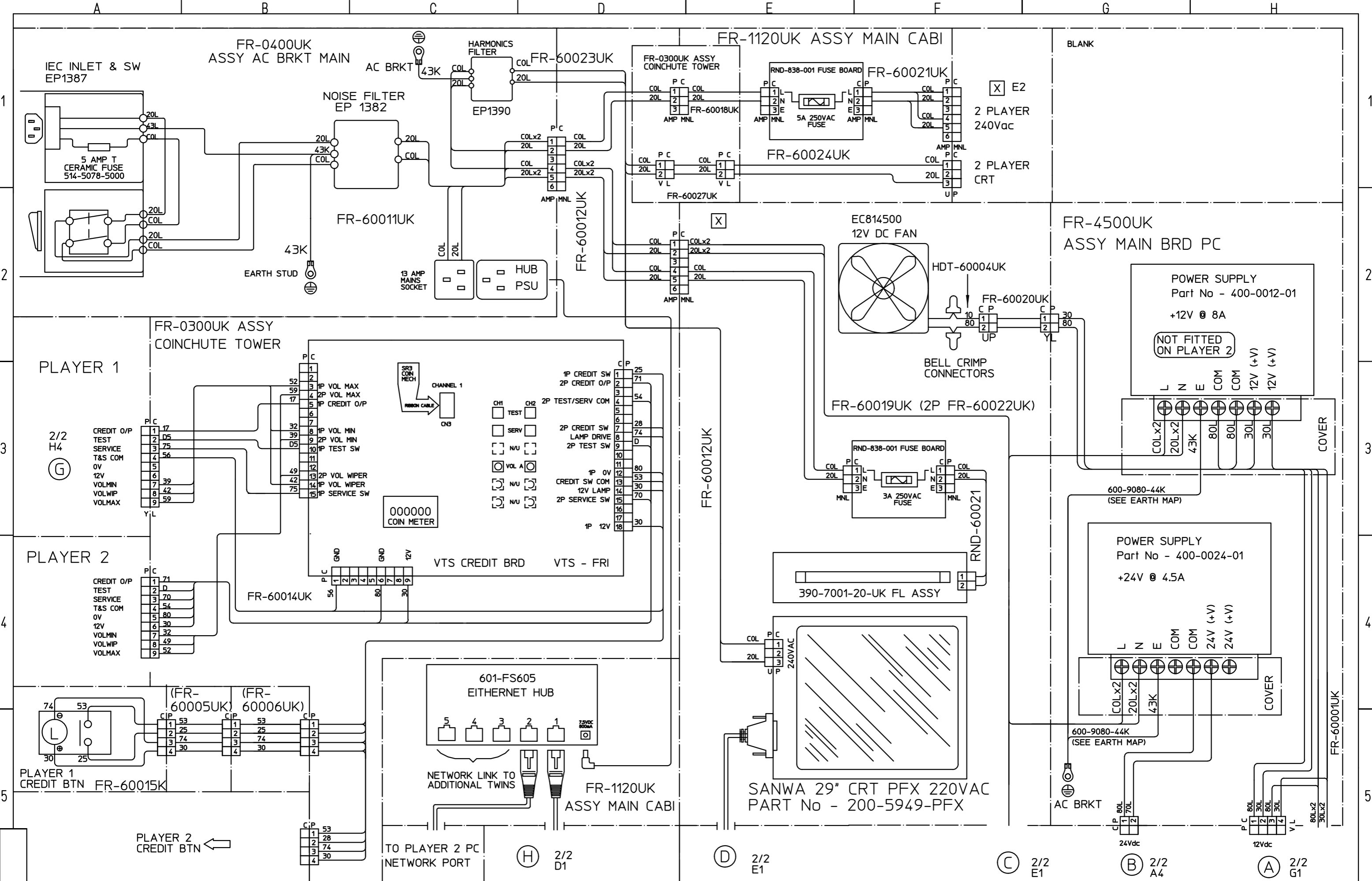

1 RED	8 BLACK	F LIGHT GREEN
2 BLUE	9 GREY	
3 YELLOW	A PINK	
4 GREEN	B SKY BLUE	
5 WHITE	C BROWN	
7 ORANGE	D PURPLE	

U AWG 16 UL105	AWGN	CHKD	TOP LEVEL No
K AWG 18 UL105			
L AWG 20 UL1007			

SEGA	SEGA AMUSEMENTS EUROPE, LTD.	THIS DRAWING WILL IN NO WAY BE COPIED. TO BE RETURNED ON DEMAND.	ORIGINAL SIZE
FORD RACING - FULL BLOWN (TWIN)			A3
DESCRIPTION			1/2
PART NO.			

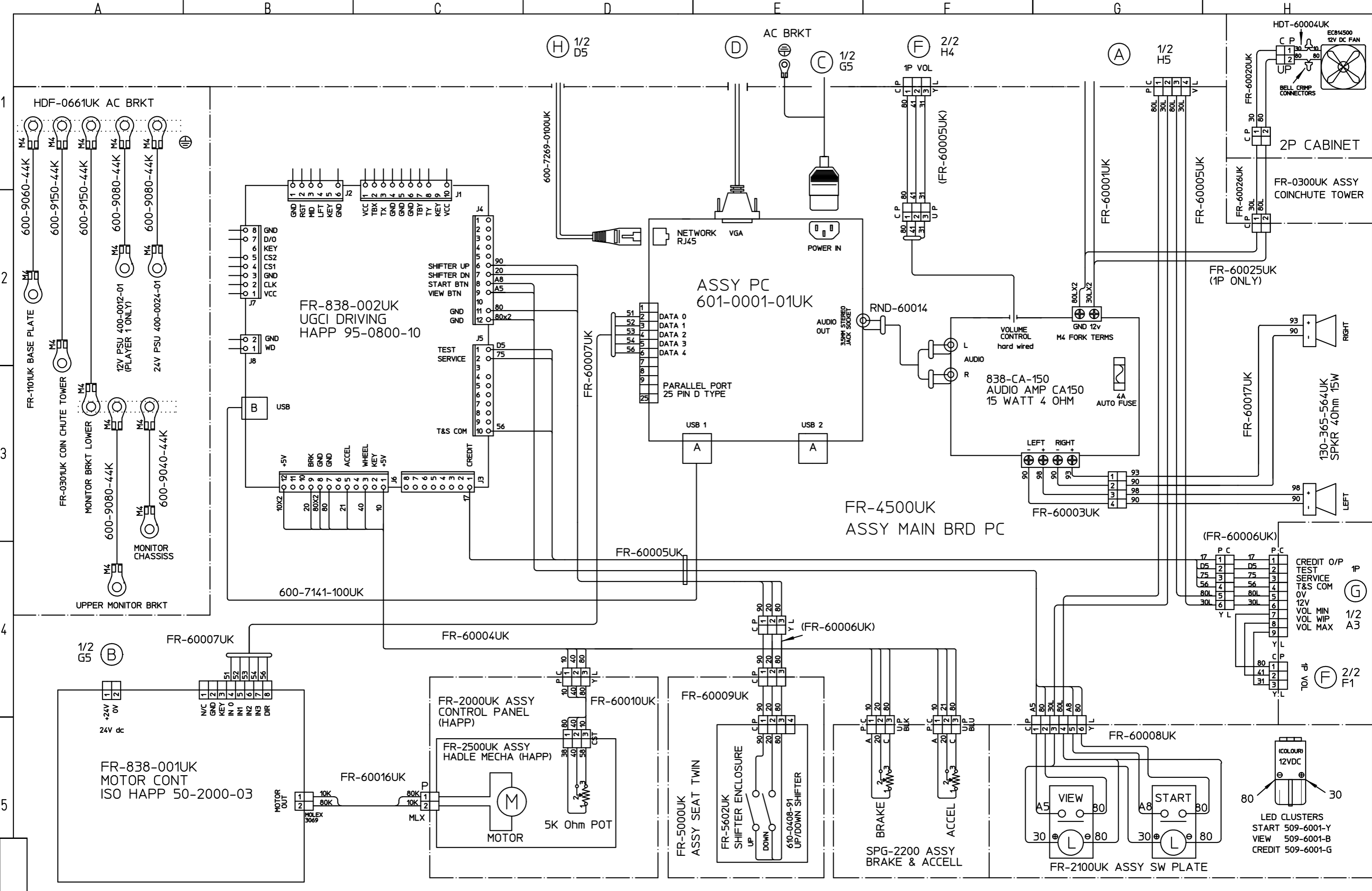

1 RED	8 BLACK	F LIGHT GREEN
2 BLUE	9 GREY	
3 YELLOW	A PINK	
4 GREEN	B SKY BLUE	
5 WHITE	C BROWN	
7 ORANGE	D PURPLE	

U	AWG	UL
AWG 16	UL105	
AWG 18	UL105	
AWG 20	UL1007	
AWG 22	UL1007	

DRAWN	CHKD	TOP LEVEL No	<b>SEGA AMUSEMENTS EUROPE, LTD.</b>	THIS DRAWING WILL IN NO WAY BE COPIED. TO BE RETURNED ON DEMAND.	ORIGINAL SIZE <b>A3</b>
CW		FR-00001UK			
<b>FORD RACING - FULL BLOWN (TWIN)</b>					
07/04/06				DESCRIPTION	PART NO.

## SEGA AMUSEMENTS EUROPE

Suite 3a, Oaks house  
12-22 West Street  
Epsom  
Surrey  
KT3 7RG  
U.K.

### UK Customers

Tel: +44(0) 1372 731820

Fax: +44(0) 1372 731849

# SEGA



© SEGA 2006



This symbol on the product or on its packaging indicates that this product must not be disposed of within the normal waste stream. Instead, it is your responsibility to dispose of the equipment by handing it over to a designated collection point for the recycling of waste electrical and electronic equipment. The separate collection and recycling of your waste equipment at the time of disposal will help to conserve natural resources and ensure that it is recycled in a manner that protects human health and the environment. For

more information about where you can drop off your waste equipment for recycling, please contact your local city office, your household waste disposal service or where you purchased the product. SEGA AMUSEMENT EUROPE encourages the recycling of its products is committed to transitioning its products to meet with WEEE and RoHS requirements. We have been in constant talks with our suppliers and are confident we will reach our goal before the European deadline of July 2006.