

namco®

PAC-MAN BALL

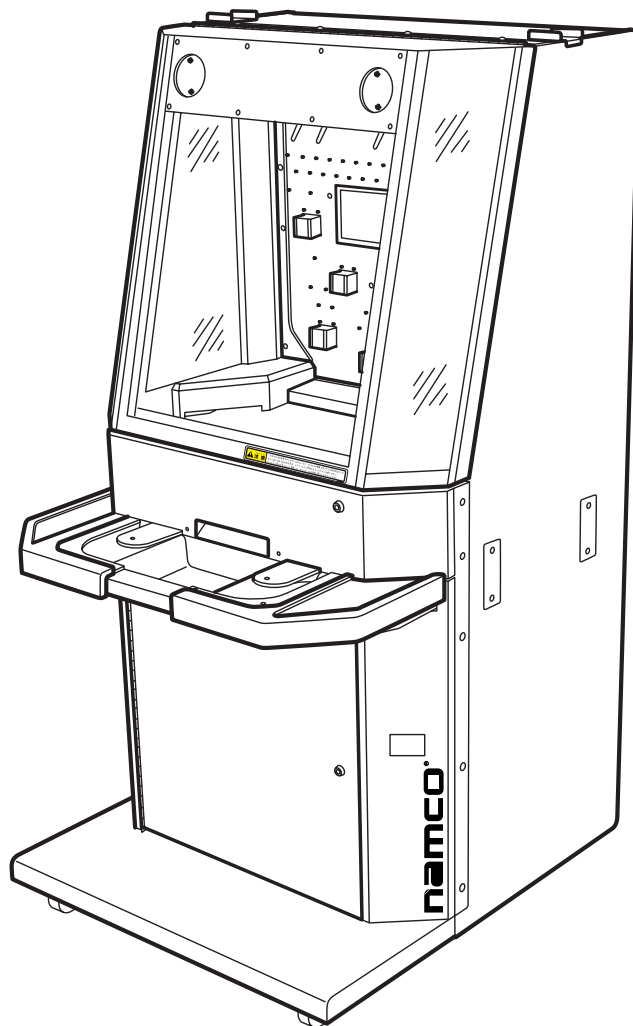

OPERATORS MANUAL

IT IS THE RESPONSIBILITY OF THE OPERATOR TO MAINTAIN CUSTOMER SAFETY AT ALL TIMES, AND IT IS IMPERATIVE THAT THE DETAILS SET OUT IN THIS MANUAL ARE FOLLOWED PRECISELY

Contents

OPERATORS MANUAL	1
GENERAL SAFETY CONSIDERATIONS.....	6
ALLGEMEINE SICHERHEITSHINWEISE	8
GENERELLE SIKKERHEDSOVERVEJELSER	10
CONSIDERACIONES GENERALES DE SEGURIDAD.	12
CONSIGNES GENERALES DE SECURITE	14
ΕΞΕΤΑΣΗ ΓΕΝΙΚΗΣ ΑΣΦΑΛΕΙΑΣ	16
CONSIDERAZIONI GENERALI SULLA SICUREZZA	18
VANLIGE SIKKERHETSTILTAK	20
ALGEMENE VEILIGHEIDSOVERWEGINGEN	22
AVISOS DE PERIGO	24
ALLMÄNNA SÄKERHETSBEAKTANDEN	26
YLEISET TURVALLISUUNÄKÖKODAT	28
1. SPECIFICATIONS	30
2. MAIN COMPONENTS	31
3. HOW TO PLAY	32
4. INSTALLATION	33
4-1 Notes on Installation	36
4-2 Lowering the Level Adjusters	36
4-3 Adjusting the Tilt Sensitivity	37
4-4 Loading with Coins.....	38
4-4-1 Loading Coin Hopper (C)	38
4-4-2 Loading Coin Hoppers (L) and (R)	39
4-4-3 Loading the Playfield	40
5. ADJUSTMENTS	42
5-1 Adjustment of the Payout Rate	43
5-1-1 Adjustment of the Front Edge	43
5-1-2 Measurement of the Field Payout Rate	44
5-1-3 Basic Payout Rate	44
5-1-4 Adjustment of the Side Edges	45
5-3 Resetting the Tilt	46
5-4 Adjusting for Coin Acceptance	47
5-4-1 Adjustment of the Coin Acceptors	47

5-5	Adjusting the Coin Entry	50
5-6	Adjustment Switches	52
5-7	Test Mode	53
5-7-1	Displaying and Initializing the Data	54
5-7-1-1	Income Data	54
5-7-1-2	Security Data	55
5-7-1-3	Machine Data (hardware data)	56
5-7-1-4	Error History	57
5-7-2	Options	58
5-7-3	Input/Output Test	59
5-7-3-1	I/O Test	60
	Sensor Test (Test page 1 of 4)	60
	Motor Test (Test page 2 of 4)	61
	Solenoid Test (Test page 3 of 4)	62
	LED / Lamp Test (Test page 4 of 4)	63
5-7-3-2	Switch Test	64
5-7-3-3	Field P/O Measurement Mode (field payout rate measurement mode)	65
5-7-4	Monitor Test	68
5-7-5	Sound Test	69
5-7-6	Others	70
6.	MAINTENANCE	72
6-1	Regular Inspection	74
6-2	Cleaning	75
6-2-1	Cleaning the Coin Trays	75
6-2-2	Cleaning the Bonus Exit	75
6-2-3	Cleaning the Payout Assy	76
6-2-4	Cleaning the Coin Selector	78
6-2-5	Cleaning the Coin Hoppers	80
6-2-6	Collecting Coins from Hoppers and Escalators.	81
6-2-6-1	Escalator Section	82
	Removing Actuator Covers	82
	Top Section	83
	Middle Section	84
	Hopper Section	85
6-2-6-2	Hopper	86

6-2-7	Cleaning the Main Panel and Main Cover	88
6-2-8	Cleaning the Dust Box	89
6-2-9	Removing Jammed Coins from the Panel Assy	90
6-3	Errors	91
6-3-1	Error Display	91
6-3-2	Unprocessed Coins Error Display	92
6-3-3	List of Error Indications	93
6-3-4	Resetting Errors	96
7.	REPLACING PARTS	97
7-1	Lamps	97
7-2	PC Board Base	100
7-3	Playfield Assembly	103
7-3-1	Replacing the Pusher Motor	103
7-3-2	Replacing the Pusher Sensor	105
7-3-3	Replacing the Flange Bushing	106
7-4	Panel Assembly	109
7-4-1	Replacing the Sensor PC Board	109
7-4-2	Replacing the Checker Unit	110
7-4-3	Replacing the Checker Sensors	111
7-4-4	Replacing the LED PC Board	112
7-4-5	Replacing the Wiper Motor	113
7-4-6	Replacing the LED Assembly	115
7-5	Payout Assembly	116
7-6	Replacing the Arm rests	118
7-7	Coin Selector (L), (R) Assemblies	119
7-7-1	Removing the Coin Selector (L), (R) Assys	119
7-7-2	Replacing the Coin Sensors	120
7-7-3	Replacing the Lock-Out Solenoids	121
7-7-4	Coin Divider (L), (R) Assys	122
7-7-4-1	Removing the Coin Divider (L), (R) Assys	122
7-7-4-2	Replacing the Divider Solenoid Sensors	123
7-7-4-3	Replacing the Divider Solenoids	124
7-8	Coin Hoppers	125
7-8-1	Replacing the Coin Hoppers (L), (R)	125
7-8-2	Removing the Escalators	127

7-8-3 Removing Coin Hopper C.....	128
7-8-4 Removing Hopper C Escalator	130
7-8-5 Replacing the Polysliders	131
8. PARTS	132
8-1 Cabinet.....	132
8-2 Front Door Assy	136
8-3 Playfield Door Assy	137
8-4 PC Board Base Assy	138
8-5 Armrest Assy	139
8-6 Playfield Assy	140
8-7 Play Panel Assy	142
8-8 Coin Selector (L), (R) Assys	144
8-9 Payout Assys	146
8-10 Coin Divider (L), (R) Assys Assys	147
9. SCHEMATICS	132



No part of this publication may be reproduced by any mechanical, photographic or electronic process, or in the form of phonographic recording, nor may it be stored in a retrieval system, transmitted or otherwise copied for private use, without permission from **NAMCO EUROPE LIMITED**.

While the information contained in this manual is given in good faith and was accurate at the time of printing, NAMCO EUROPE LIMITED reserve the right to make changes and alterations without notice.

This equipment has been manufactured in accordance with European Directives, and has been tested and complies with the directives 89/336/EEC and 72/23/EEC by the application of EN55014-1, EN55014-2 and EN60335-2-82 standards and as such bears the CE marking. Any changes or modifications to this equipment must be in accordance with the European Directives. Any unauthorised changes to this equipment may contravene such directives.

Under some conditions of extreme external interference, e.g. radio transmissions, electrostatic discharge or mains born transients, some degradation of performance may occur. However the equipment will recover normal performance once the source of interference has ceased or been removed.

Following abnormally high surges on the mains supply, the video monitor may need to be manually reset by turning the equipment OFF and back ON.

If the game processor resets due to an interruption of the mains voltage, any credits established will be lost.

This equipment is not a machine as defined by the machinery directive 89/392/EEC.

SAFETY WARNING

In order to use this equipment safely, be sure to read this Operators Manual carefully before installation, adjustment or use of this equipment.

Whenever the owner of this equipment entrusts dis-assembly, installation, adjustment or routine maintenance to another person, the owner should ensure that that person read the appropriate precautions and relevant sections of this manual before starting work.

In order that no accidents occur when the equipment is in operation, strictly follow the notes on safety as described below.

This manual along with the Installation Manual (where applicable) form an integral part of the equipment and must be available to the operating or service personnel at all times.

This equipment is for indoor use only and should only be used for the purpose intended.

Namco Europe Ltd. bears no responsibility for accidents, injury or damage resulting from unauthorized changes to, or improper use of this equipment.

SAFETY NOTES

The following safety notes are used throughout this manual. Familiarize yourself with each of these notes and it's meaning before installing, servicing or making adjustments to this equipment.

WARNING | Warning denotes a hazard that could result in injury or death. Do not proceed beyond a warning note until the indicated conditions are fully understood and met.

CAUTION ⓘ Caution denotes a hazard that could result in damage to the equipment. Do not proceed beyond a caution note until the indicated conditions are fully understood and met.

GENERAL SAFETY CONSIDERATIONS

- | **Only operate this equipment after checking that it has been installed correctly and in accordance with this manual.**
- | **Installation, service, adjustment or routine maintenance should be carried out by suitably qualified persons only.**
- | **For continued protection against fire hazard, replace fuses with the same type and rating. The use of other fuses or material is prohibited.**
- | **To prevent possible electric shock due to failure, this equipment MUST be fitted with a securely connected EARTHED plug.**
- | **If at any time the mains lead becomes damaged, it must be replaced immediately.**
- | **Do not turn the power switch ON until the equipment has ben installed correctly.**
- ⓘ Before connecting the machine to the mains supply, ensure that the equipment is set for the correct voltage and that the correct fuse are fitted.

NOTES ON INSTALLATION

- | **NEVER** turn the power to the machine **ON** until installation has been completed.
- | In order to prevent possible electric shocks, be sure that the equipment is connected to the mains with a securely connected earthed plug.
- | In order to avoid damage to the equipment due to mis-operation, ensure that the voltage of the mains supply is 230volts AC.

Note: If the location of this equipment has a polished floor, it is recommended that rubber pads are fitted under the level adjusters to prevent the equipment sliding on the floor when in use.

Note: In order to gain access to the Power Supply and CPU assemblies, ensure that the rear of the equipment is separated from a wall or other equipment by at least 500mm

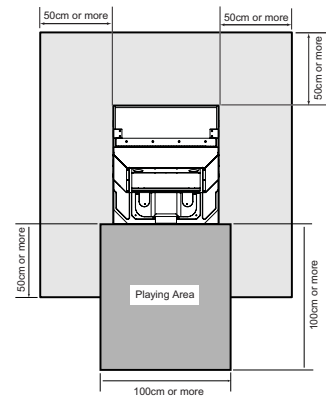

MOVING THE EQUIPMENT

- | This equipment is fitted with castors to make it easier to move. Take care when moving the equipment on an inclined surface.
- | The overall height of the equipment , with the Header Assembly fitted, is 1915mm. Take care of any overhead obstructions. (e.g. Light Fittings, Electric Cables etc.)

REMOVING AND REPLACING PARTS

- | Adjustments or maintenance on this equipment should be carried out by suitably qualified personnel only.
- | Do not make any alteration to this equipment without prior approval. Doing so could cause unforeseeable danger.
- | Only parts specified by Namco Europe Ltd. should be used when replacing parts. (Including screws)
- | Ensure that the power to the equipment is turned OFF before commencing any maintenance work. (Trouble shooting, repairs etc.)
- | If performing work not described in this manual, contact your distributor for instructions, as no responsibility will be accepted for damage or injury.
- | Parts of the Power Supply remain hot and carry high voltage even after switching OFF and could cause burns or electric shock. Take care not to touch these parts accidentally.
- | Make sure that the equipment is switched OFF before connecting or disconnecting any plugs or connectors.
- | When moving the mains connector from the equipment, or the mains plug from the wall outlet, always grasp the plug and not the cable.



Dieses Dokument darf in keiner Weise vervielfältigt werden. Jegliche Tonaufnahmen sowie die Speicherung auf Datenträger (Suchsysteme), die Weitergabe oder sonstiges Kopieren für den gewerblichen und privaten Gebrauch sind untersagt und bedürfen der vorherigen Genehmigung durch NAMCO EUROPE LIMITED.

Die Informationen in diesem Handbuch entsprechen den Tatsachen bei Drucklegung. NAMCO EUROPE LIMITED behält sich jedoch das Recht zu Änderungen ohne vorherige Bekanntgabe vor.

Dieses Gerät trägt das CE-Zeichen und wurde gemäß den EU-Richtlinien produziert. Es erfüllt die Richtlinien 89/336/EEC und 72/23/EEC und Standards EN 55014-1, EN55014-2 und EN60335-2-82 (s. Deckblatt des Handbuchs). Alle Veränderungen an diesem Gerät müssen in Übereinstimmung mit den EU-Richtlinien erfolgen. Nicht genehmigte Veränderungen an diesem Gerät verstoßen gegen diese Richtlinien.

Extreme äußere Störungen, wie z.B. durch Radiobetrieb, elektrostatische Entladung oder zeitweilige Netzschwankungen können zu einer Leistungsminderung führen. Sobald diese Faktoren jedoch ausgeschaltet oder beseitigt wurden, erreicht das Gerät seine normale Leistung.

Achtung! Falls der Spielprozessor auf Grund von Netzunterbrechungen oder Abnahme der Netzspannung aussetzt, kann es zum Verlust von Spielkrediten kommen.

Dieses Gerät fällt nicht unter die Maschinen-Richtlinie 89/392/EEC

SICHERHEITSHINWEISE

Um einen ordnungsgemäßen Betrieb dieses Gerätes zu gewährleisten, muß vor Aufstellung, Inbetriebnahme und Gebrauch das Handbuch sorgfältig gelesen werden.

Sobald der Besitzer dieses Gerätes die Demontage, Aufstellung, Inbetriebnahme oder den Service einer anderen Person überträgt, muß er sicherstellen, daß diese Person vor Arbeitsbeginn die nötigen Sicherheitshinweise und die dazugehörigen Kapitel des Handbuchs liest und versteht.

Um jegliche Unfälle während des Betriebes zu vermeiden, müssen obige Hinweise strikt befolgt werden.

Dieses Handbuch sowie das spezielle Geräte-Handbuch (wenn vorhanden) gehören zum Gerät und müssen dem Betreiber und Wartungspersonal stets zugänglich sein

Dieses Gerät ist ausschließlich für den gewerblichen Gebrauch in geschlossenen Räumen bestimmt und darf nur dort betrieben werden.

NAMCO EUROPE Ltd. übernimmt keinerlei Haftung für Unfälle, Verletzungen oder Beschädigungen, die auf nicht genehmigte Veränderungen oder unsachgemäßen Betrieb des Gerätes zurückzuführen sind.

SICHERHEITSHINWEISE

Folgende Sicherheitsbegriffe werden im gesamten Handbuch benutzt. Machen Sie sich daher bitte vor Inbetriebnahme, Wartung und Durchführung von Einstellungen am Gerät mit diesen Warnhinweisen vertraut.

WARNUNG | **WARNUNG** bezeichnet eine Gefahrenquelle für Leib und Leben. Erscheint dieser Warnhinweis, darf erst weitergearbeitet werden, wenn die entsprechenden Erklärungen vollständig verstanden und befolgt wurden.

VORSICHT ⓘ **VORSICHT** bezeichnet eine Gefahrenquelle für die Beschädigung des Gerätes. Erscheint dieser Warnhinweis, darf erst weitergearbeitet werden, wenn die entsprechenden Erklärungen vollständig verstanden und befolgt wurden.

ALLGEMEINE SICHERHEITSHINWEISE

| **Das Gerät darf nur betrieben werden, nachdem es vorschriftsmäßig und in Übereinstimmung mit dem Handbuch aufgestellt wurde.**

| **Die Warnschilder müssen in gutem Zustand sein und ersetzt werden, wenn sie nicht mehr gut lesbar sind.**

| **Bei Auftreten eines Fehlers oder Problems muß das Gerät sofort abgeschaltet werden und darf erst nach fachgerechter Behebung des Fehlers wieder in Betrieb genommen werden.**

| **Aufstellung, Service, Einstellungen und Wartung dürfen nur von dafür qualifiziertem Fachpersonal durchgeführt werden.**

| **Zur Vermeidung von Feuer, defekte Sicherungen nur durch vorgeschriebene Sicherungen ersetzen. Die Verwendung von andersartigen Sicherungen oder unterschiedlichem Material ist untersagt.**

| **Zur Vermeidung von Elektroschlägen muß dieses Gerät mit einem ordnungsgemäß geerdeten Netzstecker versehen sein.**

| **Bei Beschädigungen des Netzteiles muß dieses umgehend ersetzt werden.**

| **Gerät erst nach abgeschlossener Aufstellung einschalten.**

ⓘ Vor Einstecken des Netzsteckers bitte sicherstellen, daß Netzspannung und Gerätespannung übereinstimmen, und die vorgeschriebenen Sicherungen verwendet wurden.

HINWEISE ZUR AUFSTELLUNG

- | **NIEMALS** das Gerät einschalten bevor die Aufstellung völlig abgeschlossen ist.
- | Zur Vermeidung von Elektroschlägen muß das Gerät mit einem ordnungsgemäß geerdetem Netzstecker an die Stromversorgung angeschlossen werden.
- | Zur Vermeidung von Beschädigungen durch Fehlbetrieb am Gerät sicherstellen, daß die Netzspannung 230 Volt beträgt.

Hinweis: Ist das Gerät für einen Aufstellplatz mit glattem Fußboden bestimmt, müssen die Standbeine mit Gummiplättchen unterlegt werden, damit das Gerät fest steht und nicht auf dem Boden hin- und herrutscht.

Hinweis: Zu Reparaturzwecken am Netzteil und den CPU-Komponenten muß die Rückseite des Gerätes mindestens 50cm von anderen Geräten und der Wand entfernt sein.

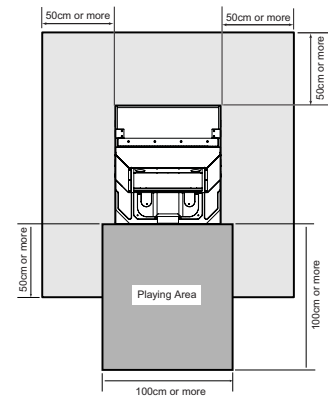

- | Zum leichteren Transport ist das Gerät mit Rollen ausgerüstet. Daher besondere Vorsicht auf abschüssigem Boden
- | Die Gesamthöhe de Gerätes beträgt 1.915m. Daher Vorsicht bei tiefer hängenden Beleuchtungskörpern.

AUS- UND EINBAU VON KOMPONENTEN UND TEILEN

- | Aufstellung, Service, Einstellung und Wartung dürfen nur von dafür qualifiziertem Fachpersonal durchgeführt werden.
- | Es dürfen keierlei Veränderungen ohne vorherige Genehmigung am Gerät vorgenommen werden. Zuwiderhandlungen stellen eine Gefahrenquelle dar.
- | Für die Repartur dürfen nur Originalersatzteile (incl. Schrauben) von NAMCO EUROPE LTD. verwendet werden.
- | Vor Beginn aller Wartungsarbeiten (Fehlersuche, Reparaturen etc.) muß der Netzstecker gezogen werden.
- | Bei Arbeiten, die nicht in diesem Handbuch beschrieben werden, muß vorher der Händler zu Rate gezogen werden, da sonst keinerlei Haftung bei Beschädigungen und Verletzungen übernommen wird.
- | Teile des Netzteiles und Bilschirmes bleiben nach Abschalten noch heiß und führen Hochspannung. Dies kann zu Verbrennungen oder einem Elektroschlag führen. Diese Teile dürfen nicht berührt werden.
- | Vor der Montage oder dem Entfernen von Steckverbindungen und Steckern muß das Gerät ausgeschaltet werden.
- | Bei Ziehen des Gerätesteckers oder des Netzsteckers aus der Wandsteckdose stets den Stecker greifen und nicht das Kabel.



Denne udgivelse må ikke reproducere af nogen som helst mekanisk, fotografisk eller elektrisk proces eller i form af indspilning, den må heller ikke lagres i et eftersøgningsystem transmitteres eller kopieres til nogen form for offentlig benyttelse uden tilladelse fra **Namco Europe Limited**.

Da informationerne i denne manual er givet med god tro og var korrekt på udskivningstidspunktet, forbeholder Namco Europe Limited sig retten til, at foretage ændringer og forandringer uden varsel.

Denne maskine er fremstillet i overensstemmelse med Det Europæiske fællesskabs direktiver og er blevet testet og fuldendt med direktiverne 89/336/EEC og 72/23/EEC standarder (se manualens forside) og som sådan bærer CE mærket. Enhver form for ændring eller modifikation af denne maskine skal være i overensstemmelse med Det Europæiske fællesskabs direktiver.

I tilfælde af forbigående ekstreme eksterne forstyrrelser, så som radio udsendelser, elektronisk afgivelse eller forstyrrelser på ledningsnettet, kan nedbrydning forekomme. Maskinen vil dog køre normalt så snart forstyrrelsen ophører eller bliver fjernet.

Bemærk:- Hvis spilleprocessoren resetter p.g.a. en forstyrrelse eller reduktion af hovedstrømmen kan de etablerede kreditter gå tabt.

Dette spil er ikke en maskine defineret af maskin direktivet 89/392/EEC -

SIKKERHEDS ADVARSEL

For at betjene denne maskine sikkert, læs da denne brugemanual grundigt før installation, justering eller brug af maskinen. Når som helst ejeren af denne maskine overlader demontering, installation, justeringer eller daglig vedligehold til en anden person, skal ejeren sikre sig at denne person læser de sikkerhedsregler og relevante punkter i denne manual før arbejdet begynder. For at undgå ulykker når maskinen er i gang, følg nøje de sikkerhedsregler der er beskrevet herunder. Denne manual sammen med installations manualen er en uløselig del af udstyret og skal altid være til rådighed for det arbejdende og servicerende personale. Denne maskine er kun til indendørs brug og bør kun bruges til det beregnede formål. Namco Ltd. bærer intet ansvar for ulykker eller skader som er et resultat af uautoriserede ændringer eller fejlagtig brug af denne maskine.

SIKKERHEDSREGLER

De følgende sikkerhedsregler er brugt helt igennem denne manual. Gør dig bekendt med hver enkelt af dem og meningen heraf før installation, servicering eller justering af denne maskine.

ADVARSEL | Advarsel betegner en episode der kan resultere i skader eller død. Begiv dig ikke forbi et advarselsskilt før de indikerede betingelser er fuldstændig forstået.

FORSIGTIG ⓘ Forsigtig betegner en episode der kan resultere i ødelæggelse af maskinen. Begiv dig ikke forbi et advarselsskilt før de indikerede betingelser er fuldstændig forstået.

GENERELLE SIKKERHEDSOVERVEJELSER

- | **Betjen kun maskinen efter at have tjekket, at den er korrekt installeret og er i overensstemmelse med manualen.**
 - | **Advarselsskiltene skal altid være i god stand og erstattes hvis de er slidt, så kunden tydeligt kan læse dem.**
 - | **Hvis der er en fejl eller et problem med maskinen skal betjening straks stoppes, og problemet afhjælpes før yderligere brug.**
 - | **Installations service, justeringer eller daglig vedligehold bør kun udføres af en kvalificeret person.**
 - | **For fortsat beskyttelse mod brandfare, sikres at hoved sikringerne kun erstattes med samme type kapacitet. Brug af anden kapacitet eller materiale er forbudt.**
 - | **For at undgå elektrisk stød p.g.a. en fejl skal denne maskine være forbundet med et sikkert jordstik.**
 - | **Hvis hoved ledningerne på noget tidspunkt bliver beskadiget skal de strakt erstattes.**
 - | **Tænd ikke for strømmen før maskinen er korrekt installeret.**
- ⓘ Før tilslutning af maskinen til hovedstrømmen sikres, at maskinen er indstillet til den rette spænding.

PUNKTER OM INSTALLATION

- | **Tænd aldrig for strømmen til maskinen før installation er fuldført.**
- | For at undgå mulige elektriske stød sikres, at maskinen er forbundet til hovedstrømmen med sikkert monterede jordstik.
- ⓘ For at undgå skader på maskinen p.g.a. fejlbetjening sikres, at spændingen på hovedstrømmen er 230 volt AC.

BEMÆRK : Hvis denne maskine placeres på et poleret gulv, anbefales det at ligge gummimåtter under justeringsfødderne for at undgå at maskinen glider på gulvet.

BEMÆRK : For at få adgang til strømforsyningen og CPU justeringer sikres, at bagsiden af hoved kabinettet står adskilt fra andre maskiner eller væggen med mindst 50cm.

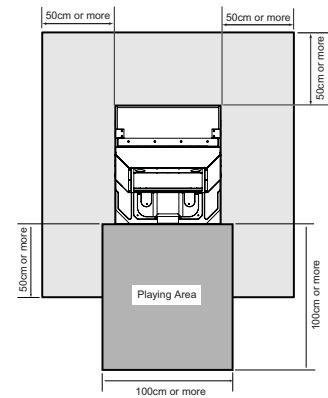

- | **Maskinen er smurt med olie for at gøre den lettere bevægelig. Pas på når maskinen flyttes på en skrå overflade.**
- | **Den fulde højde af hoved sektionen er 1.915m. Pas på øvre forhindringer f.eks. lys inventar**

AT FJERNE OG UDSKIFTE SEKTIONER OG DELE.

- | **Justeringer eller vedligehold af denne maskine bør kun udføres af kvalificeret personale.**
- | **Skift ikke noget på maskinen uden godkendelse, det kan føre til uforudset fare.**
- | **Der bør kun bruges dele specificeret af Namco Europe Limited når der skiftes eller repareres dele (inklusive skrue).**
- | **Sørg for, at strømmen til maskinen er slukket før der foretages nogen form for arbejde (fejlfinding, reparation etc.)**
- | **Hvis der foretages arbejde der ikke er beskrevet i denne manual, kontakt da din leverandør for at få kyndig vejledning, da intet ansvar vil blive accepteret ved skader.**
- | **Dele af strømforsyningen og monitoren forbliver varme eller bærer høj spænding selv efter maskinen er slukket, det kan føre til forbrændinger eller elektriske stød. Pas på ikke at røre disse dele ved et uheld.**
- | **Læg mærke til at maskinen er slukket før samlinger eller stik tages ud eller sættes i.**
- | **Når hovedsamlingen fjernes fra maskinen eller hovedstikket fjernes fra væggen, tag da altid ved stikket, ikke ledningen.**



No se permite la reproducción total ni parcial de esta publicación por ningún medio mecánico, fotográfico o electrónico, grabaciones fonográficas, ni su almacenamiento informático, su transmisión o su copia, ya sea para uso público o privado, sin permiso de NAMCO EUROPE LIMITED.

Si bien la información contenida en este manual se da de buena fe y es correcta en el momento de su impresión, NAMCO EUROPE LIMITED se reserva el derecho de hacer cambios y alteraciones sin previo aviso.

Esta máquina ha sido fabricada según las directrices de la Comunidad Europea, ha sido probada, y se ajusta a las directrices 89/336/EEC y 72/23/EEC, mediante la aplicación de los estándares EN55014-1, EN55014-2 y EN60335-2-82 (véase cubierta del manual) y por ende lleva el sello de la C.E. Cualquier cambio o modificación que se haga a esta máquina ha de ajustarse a las directrices de la Comunidad Europea. Cualquier cambio no autorizado hecho al producto pudiera contravenir estas directrices.

Bajo ciertas condiciones de extrema interferencia externa, p. ej. transmisiones de radio, descargas electrostáticas u oscilaciones de la red eléctrica puede tener lugar un descenso del rendimiento. No obstante, la máquina recuperará su rendimiento normal una vez que la fuente de interferencias sea retirada o cese de producirlas.

Nota: Si el procesador de juegos se reinicializa a causa de caídas o interrupciones en la alimentación eléctrica, se perderán todos los créditos.

Este juego no se ajusta a la definición de máquina de la Normativa de Maquinaria 89/392/EEC

AVISOS DE SEGURIDAD.

Para utilizar esta máquina con seguridad, lea cuidadosamente este Manual de Operador antes de proceder a la instalación, ajuste o uso de esta máquina.

Cada vez que el propietario de esta máquina confíe a terceros su desmontaje, instalación, ajuste o mantenimiento rutinario deberá asegurarse de que tales personas lean las precauciones adecuadas y las secciones relevantes de este manual antes de comenzar su trabajo.

Para que no ocurra accidente alguno mientras la máquina se encuentre en funcionamiento, siga estrictamente las notas de seguridad tal como más adelante se describen.

Este manual, junto con el Manual de Instalación (cuando proceda), forma parte integral del equipo y debe estar a disposición del personal de mantenimiento y operación en todo momento.

Esta máquina es únicamente para ser usada en interiores, y sólo debe usarse para aquello para lo que ha sido creada.

Namco Ltd. queda exenta de cualquier responsabilidad por accidentes, heridas o daños causados por cambios no autorizados o uso indebido de esta máquina.

NOTAS DE SEGURIDAD.

En este manual se usan las notas siguientes. Familiarícese con cada una de ellas y su significado antes de instalar, revisar, o hacer ajustes en esta máquina.

AVISO. | **Aviso señala un riesgo que puede ocasionar lesiones o la muerte. Tras ver esta nota, no continúe hasta entender completamente y cumplir las condiciones exigidas.**

PRECAUCIÓN. ⓘ **Precaución señala un riesgo que puede ocasionar daños a la máquina. Tras ver esta nota, no continúe hasta entender completamente y cumplir las condiciones exigidas.**

CONSIDERACIONES GENERALES DE SEGURIDAD.

| **Opere sólo con esta máquina tras comprobar que ha sido instalada correctamente y de acuerdo con este manual.**

| **Las notas de aviso deben mantenerse siempre en buen estado y reemplazarse si estuvieran desgastadas para que los usuarios puedan leerlas con claridad.**

| **Si hubiera algún error o problema con la máquina, debe interrumpirse su operación inmediatamente, y subsanar el problema antes de volver a usarla.**

| **Las revisiones de instalación, los ajustes, y el mantenimiento rutinario deberán llevarse a cabo sólo por personal cualificado.**

| **Para asegurar una continua protección contra riesgo de incendios, asegúrese de que los fusibles eléctricos sean reemplazados solamente por otros del mismo tipo y especificaciones. El uso de otros fusibles o material está prohibido.**

| **Para evitar posibles descargas eléctricas por cortes, esta máquina debe estar provista de un enchufe debidamente conectado, con TOMA DE TIERRA.**

| **Si en cualquier momento el cable de alimentación se dañara, deberá ser reemplazado inmediatamente.**

| **No encienda el interruptor de la máquina hasta que ésta haya sido correctamente instalada.**

ⓘ **Antes de enchufar la máquina a la red eléctrica, asegúrese de que la máquina está preparada para el voltaje correcto, y de que se usan los fusibles adecuados.**

NOTAS DE INSTALACIÓN.

JAMÁS ENCIENDA la máquina antes de haber completado la instalación.

Para evitar posibles descargas eléctricas, asegúrese de que la máquina está conectada a la red con un enchufe provisto de toma de tierra.

i Para evitar daños a la máquina causados por operación incorrecta, asegúrese de que el voltaje de la red es de 230 voltios, corriente alterna.

Notas : Si el lugar donde se instalará la máquina tiene un piso pulido, se recomienda colocar tacos de goma bajo los ajustadores de nivel para evitar que la máquina se deslice por el suelo.

Notas : Para acceder a las unidades de Fuente de Alimentación y CPU, asegúrese de que la parte trasera del mueble principal está separada de muros u otras máquinas al menos 500 mm.

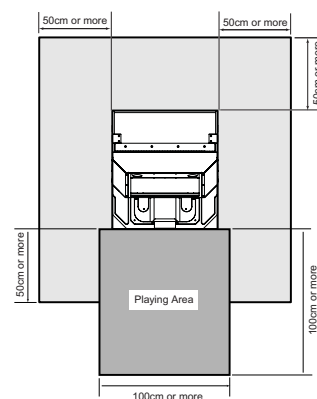

El juego tiene ruedecitas para hacer más fácil su traslado. Tenga cuidado al mover la máquina en una superficie inclinada.

La altura total de la Unidad principal es de 1.915mm. Tenga cuidado de que no haya obstáculos p. ej. luces.

RETIRAR Y REEMPLAZAR PARTES Y UNIDADES.

Las revisiones de instalación, los ajustes, y el mantenimiento rutinario deberán llevarse a cabo sólo por personal cualificado.

No realice alteraciones en esta máquina sin aprobación previa. De hacerlo así, pueden causar peligros imprevisibles.

Sólo deben usarse las partes especificadas por Namco Europe Ltd. para reparaciones o reemplazos (incluidos los tornillos).

Asegúrese de que la máquina está desconectada antes de comenzar cualquier trabajo de mantenimiento (reparaciones, resolución de problemas, etc.)

Al realizar trabajos no descritos en este manual, póngase en contacto con su distribuidor para recibir instrucciones. Se declina cualquier responsabilidad por daños o lesiones.

Hay partes de la fuente de alimentación y del monitor que se mantienen calientes o almacenan alto voltaje incluso tras desconectar la máquina, y pueden producir quemaduras o descargas eléctricas. Tenga cuidado de no tocar accidentalmente estas partes.

Asegúrese de que la máquina está apagada antes de conectar o desconectar cualquier enchufe o conector.

Al retirar el conector principal de la máquina, o la clavija de alimentación del enchufe de la red, agarre siempre la clavija y no el cable.



Aucun élément de cette publication ne sera reproduit, ni par procédé mécanique, photographique ou électronique, ni par un moyen d'enregistrement phonographique. Ces informations ne seront ni stockées grâce à un procédé de récupération, ni transmises ou autrement copiées pour un usage public ou privé, sans l'autorisation de **NAMCO EUROPE LIMITED**.

Malgré le fait que les informations contenues dans ce manuel soient données de bonne foi et étaient actualisées au moment de leur impression, NAMCO EUROPE LIMITED se réserve le droit de procéder à des changements ou à des modifications sans avis préliminaire.

Ce jeu a été fabriqué en respect des normes de la Communauté Européenne, après avoir été testé il répond aux normes 89/336/EEC et 72/23/EEC, en application des standards EN55014-1, EN55014-2 et EN60335-2-82 (voir la couverture du manuel), et comme tel il comporte l'autocollant de conformité avec les normes de la Communauté Européenne. Tout changement non autorisé sur ce produit pourrait contrevenir à ces normes.

Sous certaines conditions extrêmes d'interférence externe, par exemple des transmissions radio, des décharges électrostatiques ou bien de interférences passagères sur le réseau, certaines dégradations ou anomalies peuvent se produire. Le jeu retrouvera cependant son état normal de fonctionnement lorsque la cause de ces anomalies aura cessé ou se trouvera déplacée.

Note:-

Si le processeur du jeu se reprogramme suite à une interruption ou une réduction de l'alimentation, les crédits qu'il aurait pu contenir peuvent se trouver perdus.

Ce jeu n'est pas une machine, telle que définie par la norme sur les machines 89/392/EEC

MESURES DE SECURITE

Afin d'utiliser ce jeu en toute sécurité, bien lire ce manuel d'utilisation avant de procéder à son installation, son réglage ou son exploitation.

Si le propriétaire de ce jeu en confie la démontage, l'installation, le réglage ou la maintenance habituelle à une autre personne, il devra s'assurer que cette personne ait lu les conseils d'utilisation et les passages du manuel se rapportant à ce thème, avant qu'elle ne commence son travail.

Afin d'éviter tout accident pendant la durée d'exploitation de ce jeu, se conformer strictment aux conseils de sécurité décrits à la suite.

Ce manuel ainsi que le manuel d'installation du jeu (là où nécessaire) font partie des éléments nécessaires à l'installation de la machine et doivent être mis à la disposition de l'utilisateur et du personnel de maintenance à tout moment.

Ce jeu est uniquement destiné à un usage intérieur et devra être utilisé comme tel.

Namco Ltd. ne sera aucunement tenu responsable en cas d'accidents, de blessure ou de dommage quelconque résultant de modifications non autorisées ou d'usage impropre du jeu.

REMARQUES SUR LA SECURITE

Les termes de sécurité détaillés à la suite seront utilisés tout au long de la lecture de ce manuel. Il convient de vous familiariser avec chacun de ces termes ainsi que leur signification avant de procéder à l'installation, à la maintenance ou au réglage du jeu.

AVERTISSEMENT | Ce terme annonce un danger qui pourrait éventuellement avoir des conséquences dommageables ou mortelles. **Ne pas passer outre ce signal jusqu'à ce que les conditions indiquées soient entièrement comprises et effectuées.**

ATTENTION ⓘ Ce terme indique qu'un danger menace la machine. **Ne pas passer outre ce signal jusqu'à ce que les conditions indiquées soient entièrement comprises et effectuées.**

CONSIGNES GENERALES DE SECURITE

| Allumer l'appareil seulement après avoir vérifié qu'il a été correctement installé, et que les instructions du manuel ont été respectées.

| Les notes de mise en garde doivent constamment demeurer en bon état et être remplacées en cas de disparition, afin que le client puisse les lire clairement.

| S'il y a une erreur ou un problème avec la machine, l'utilisation doit être immédiatement interrompue et le problème résolu avant toute nouvelle utilisation.

| L'installation, le service, le réglage, ou la maintenance doivent être effectués uniquement par les personnes qualifiées.

| Afin d'éviter un éventuel incendie, s'assurer que les fusibles soient remplacés par le même type de fusibles et au bon voltage. L'utilisation d'autres sortes de fusibles ou autres matériels est interdite.

| Pour prévenir une éventuelle électrocution due à un défaut matériel, ce jeu DOIT être muni d'une prise de TERRE connectée en toute sécurité

| Si à tout moment les fils électriques sont endommagés, il faut les remplacer immédiatement

| Ne pas mettre le jeu en mode de fonctionnement avant qu'il n'ait été correctement installé.

ⓘ Avant de connecter la machine au réseau, s'assurer que la machine est installée sous la bonne tension et que les fusibles correspondent.

NOTES D'INSTALLATION

| **NE JAMAIS mettre le jeu en marche avant que l'installation ne soit complètement effectuée.**

| **Afin de prévenir une éventuelle électrocution, s'assurer que la machine est connectée au réseau avec une prise de terre reliée selon les normes de sécurité.**

ⓘ Afin d'éviter que la machine ne soit abimée suite à une mauvaise opération, s'assurer que la tension sur le réseau principal soit de 230 volts AC.

Note: Si l'endroit où doit être installée la machine à un sol pöli, il est recommandé de poser des tampons feutrés sous les vérins pour éviter que le jeu ne glisse sur le sol

Note: Afin de faciliter l'accès aux CPU at à l'alimentation, s'assurer qu'il y a un espace d'au moins 500 mm entre l'arrière du meuble et le mur ou tout autre jeu.

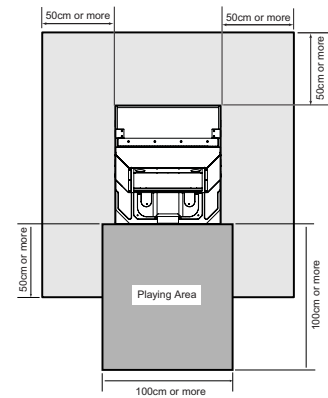

| **Le jeu est fourni avec des roulettes pour une meilleure mobilité. Prendre garde quand la machine est déplacée sur une surface inclinée.**

| **La hauteur totale de l'assemblage principal est de 1915 mm, prendre garde aux encombrements de la partie supérieure (ex : illuminations du bandeau).**

DEPLACER ET REMPLACER LES UNITES ET LES PIECES DETACHEES.

| **L'installation, le service, le réglage, ou la maintenance doivent être effectués uniquement par les personnes qualifiées.**

| **Ne pas apporter de modifications sur cette machine sans autorisation préalable, faute de quoi cela pourrait entraîner un danger.**

| **Seules les pièces détachées Namco Europe Ltd. doivent être utilisées pour le remplacement ou la réparation de pièces (y compris les vis)**

| **S'assurer que l'interrupteur soit sor OFF avant de commencer tout travail de maintenance (localisation d'une panne, réparations, etc.)**

| **Si dans ce manuel il manque une information pour réaliser un quelconque travail, contacter votre distributeur, car aucune responsabilité ne sera acceptée en cas de dommage ou de blessure.**

| **Les pièces de l'alimentation et du moniteur restent chaudes, à tension élevée même lorsque la machine est hors tension, elle pourrait occasionner des brûlures ou des électrocutions. Attention de ne pas toucher ces endroits accidentellement.**

| **S'assurer que la machine soit hors tension avant de brancher ou débrancher toute prise ou connecteur.**

| **Lorsque l'on manipule la prise au réseau de la machine, ou lorsque les prises principales doivent être débranchées, saisir toujours la prise, et non le câble.**



Κανένα μέρος αυτής της έκδοσης δεν μπορεί να αναπαραχθεί με οποιοδήποτε μηχανικό, φωτογραφικό ή ηλεκτρονικό μέσο, ή με μορφή φωνητικής ηχογράφησης και ούτε να αποθηκευτεί με επανορθωτικό σύστημα, να μεταδοθεί ή να αντιγραφεί για δημόσια ή ιδιωτική χρήση, χωρίς την άδεια της NAMCO EUROPE LIMITED.

Καθώς αυτές οι πληροφορίες σε αυτό το εγχειρίδιο έχουν δοθεί με καλή πίστη και ακριβώς την ώρα της τύπωσης, η εταιρεία NAMCO EUROPE LIMITED κρατάει το δικαίωμα να κάνει οποιοδήποτε αλλαγές χωρίς ειδοποίηση.

Τα μηχανήματα έχουν κατασκευαστεί σύμφωνα με τους όρους της Ευρωπαϊκής Κοινότητας, και έχουν ελεγχθεί σύμφωνα με τους νόμους 89/336/ΕαΚ και 72/23/ΕαΚ με την αίτηση των EN55014-1, EN55014-2 και EN60335-2-82 στάνταρτς (δες μπροστά στο εγχειρίδιο) και όλα έχουν το CE σήμα. Οποιαδήποτε αλλαγή ή μετατροπή σε αυτό το μηχάνημα πρέπει να είναι σύμφωνα με τους όρους της Ευρωπαϊκής Κοινότητας. Οποιοδήποτε αλλαγές χωρίς άδεια σε αυτό το προϊόν μπορεί να παραβεί αυτούς τους όρους.

Σε κάποιες περιπτώσεις υπερβολικής εξωτερικής παρεμβολής, π.χ. ραδιοφωνικές μεταδόσεις, ηλεκτροστατικές μεταβολές ή παροδικές εμβολές, μπορεί να παρουσιαστούν κάποιες αθλιότητες στην παρουσίαση. Πάντως το μηχάνημα θα επανέλθει στην φυσιολογική παρουσίαση εφ' όσον η πηγή της παρεμβολής σταματήσει ή απομακρυνθεί.

Σημείωση: Εάν γίνει reset στον processor του μηχανήματος κατά τη διάρκεια της κύριας παροχής, πόντοι που έχουν κερδηθεί μπορεί να χαθούν.

Αυτό το παιχνίδι δεν είναι μηχάνημα όπως προσδιορίζεται από τους όρους Μηχανημάτων 89/392/ΕαΚ.

ΟΔΗΓΙΕΣ ΑΣΦΑΛΕΙΑΣ

Για την ασφαλή χρήση του μηχανήματος, πρέπει να διαβάσεις το εγχειρίδιο χρήσης προσεκτικά πριν την εγκατάσταση, τοποθέτηση ή χρήση του μηχανήματος.

Οποιοδήποτε ο ιδιοκτήτης αυτού του μηχανήματος ζητάει από κάποιο πρόσωπο να εγκαταστήσει, να κάνει οποιαδήποτε αλλαγή ή έλεγχο ρουτίνας στο μηχάνημα, πρέπει να είναι σίγουρος ότι έχει διαβάσει τις οδηγίες αυτού του εγχειριδίου πριν να αρχίσει να δουλεύει.

Προς αποφυγήν οποιοδήποτε ατυχήματος κατά την λειτουργία του μηχανήματος, αυστηρώς ακολουθούνται οι οδηγίες ασφάλειας όπως δίνονται παρακάτω.

Αυτό το εγχειρίδιο σε συνδυασμό με το εγχειρίδιο εγκατάστασης (όπου διατίθεται) αποτελεί ένα ολοκληρωμένο μέρος των παροχών και πρέπει να είναι διαθέσιμο για την λειτουργία και το service οποιαδήποτε στιγμή.

Αυτό το μηχάνημα είναι για χρήση μόνο σε εσωτερικό χώρο και θα πρέπει να χρησιμοποιείται μόνο για τους λόγους για τους οποίους κατασκευάστηκε.

Η εταιρεία NAMCO Ltd δεν φέρει καμία ευθύνη για ατυχήματα, πληγές ή καταστροφές που μπορεί να προκληθούν από αλλαγές χωρίς άδεια σε ή εισαγωγείς αυτού του μηχανήματος.

ΣΗΜΕΙΩΣΕΙΣ ΑΣΦΑΛΕΙΑΣ

Οι ακόλουθες σημειώσεις ασφάλειας χρησιμοποιούνται μέσω αυτού του εγχειριδίου. Διάβασε αυτές προσεκτικά για να γίνει κατανοητό το νόημά τους πριν την εγκατάσταση, σέρβις ή οποιαδήποτε αλλαγή γίνεται στο μηχάνημα.

ΠΡΟΕΙΔΟΠΟΙΗΣΗ



Η προειδοποίηση αφορά κίνδυνο ο οποίος μπορεί να είναι λόγος θανάτου. Να μην προχωρήσεις σε οποιαδήποτε κίνηση μέχρι αυτοί οι όροι γίνουν κατανοητοί.

ΠΡΟΣΟΧΗ



Η προσοχή αφορά κίνδυνο ο οποίος μπορεί να προκαλέσει πρόβλημα στο μηχάνημα. Να μην προχωρήσεις σε οποιαδήποτε κίνηση μέχρι αυτοί οι όροι γίνουν κατανοητοί.

ΕΞΕΤΑΣΗ ΓΕΝΙΚΗΣ ΑΣΦΑΛΕΙΑΣ

- Αφού έχει κατανοηθεί αυτό το εγχειρίδιο, μόνο τότε να λειτουργήσει το μηχάνημα ή να γίνει έλεγχος εφ' όσον έχει γίνει η εγκατάσταση.
- Οι προειδοποιήσεις πρέπει να μένουν καθαρές και σε καλή κατάσταση ώστε ο πελάτης να τις διαβάζει καθαρά.
- Εάν υπάρχει λάθος ή πρόβλημα με το μηχάνημα, η λειτουργία πρέπει να σταματάει αμέσως και να διορθώνεται το λάθος πριν οποιαδήποτε άλλη χρήση.
- Εγκατάσταση, μετατροπή ή έλεγχος ρουτίνας μπορεί να γίνεται μόνο από εξουσιοδοτημένα άτομα.
- Για συνεχή προστασία από φωτιά, πρέπει οι ασφάλειες να αντικαθίστονται με ίδιου τύπου. Η χρήση άλλων ασφαλειών ή αντικειμένων απαγορεύεται.
- Για την αποφυγή ηλεκτρικών σοκ λόγω βλάβης, το μηχάνημα ΠΡΕΠΕΙ να έχει πρώτα ενωθεί με γείωση.
- Εάν κάποια στιγμή καταστραφεί η κύρια παροχή, πρέπει να αντικατασταθεί αμέσως.
- Να μην ανάψει το μηχάνημα (switch ON) μέχρι να έχει εγκατασταθεί σωστά και πλήρως.



Πριν την παροχή ρεύματος στο μηχάνημα, να είσαι σίγουρος ότι τα voltage και όλες οι ασφάλειες είναι σωστά ενωμένα και τοποθετημένα.

ΣΗΜΕΙΩΣΕΙΣ ΓΙΑ ΤΗΝ ΕΓΚΑΤΑΣΤΑΣΗ

- | ΠαTE να μην ανάβει το μηχάνημα εάν δεν έχει ολοκληρωθεί η εγκατάσταση.
- | Για την αποφυγή ηλεκτρικών σοκ πρέπει το μηχάνημα να έχει γειωθεί.

πρέπει η παροχή να είναι 230volt AC..

ΣΗΜΕΙΩΣΗ: Εάν το πάτωμα στο οποίο είναι τοποθετημένο το μηχάνημα γλιστράει, είναι καλό να μπει ένα κομμάτι μοκέτας για αποφυγή μετακίνησης του μηχανήματος εν ώρα λειτουργίας του.

ΣΗΜΕΙΩΣΗ: Για την εύκολη πρόσβαση στην κυρίως παροχή ή το CPU πρέπει η πίσω πόρτα του μηχανήματος να απέχει τουλάχιστον 500mm από τον τοίχο ή άλλο μηχάνημα.

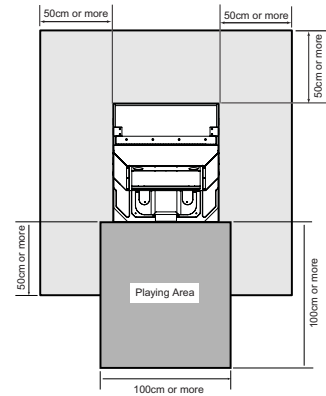

- | Το μηχάνημα είναι εφοδιασμένο με καρούλια για την εύκολη μετακίνησή του.
- | Το συνολικό ύψος της κεφαλής είναι 1915mm . Φρόντισε να μην χτυπήσει σε λάμπες κ.λ.π.

ΑΠεΜΑΚΡΥΝΣΗ ΚΑΙ ΑΝΤΙΚΑΤΑΣΤΑΣΗ ΜΕΡΩΝ - ΑΝΤΑΛΛΑΚΤΙΚΩΝ

- | Εγκατάσταση , μετατροπή ή έλεγχος ρουτίνας μπορεί να γίνεται μόνο από εξουσιοδοτημένα άτομα .
- | Δεν πρέπει να γίνονται μετατροπές στα μηχανήματα χωρίς έγκριση . Μπορεί να προκληθεί απρόβλεπτος κίνδυνος.
- | Μόνο μέρη που διευκρινίζονται από την εταιρεία NAMCO EUROPE Ltd μπορούν να χρησιμοποιηθούν για αντικατάσταση ή επιδιόρθωση. (συμπεριλαμβάνονται και οι βίδες)
- | Να είναι σίγουρα κλειστό το ρεύμα πριν οποιαδήποτε δουλειά στο μηχάνημα.
- | Εάν γίνει κάποια δουλειά στο μηχάνημα χωρίς να διευκρινίζεται στο εγχειρίδιο , να επικοινωνήσεις με τον αντιπρόσωπο για οδηγίες γιατί καμία ευθύνη δεν φέρουμε για καταστροφές ή βλάβες.
- | Μέρη του τροφοδοτικού ή του μόνιτορ παραμένουν ζεστά ή έχουν υψηλή τάση ακόμα και όταν σβήσει το μηχάνημα και μπορούν να προκαλέσουν κάψιμο ή λεκτροσόκ. Γιαυτό δεν πρέπει να έρχονται σε επαφή με χέρια .
- | Το μηχάνημα πρέπει να είναι σβηστό κατά την σύνδεση ή αποσύνδεση πρίζας ή κονέκτορα.
- | Κατά την απομάκρυνση των κεντρικών κονέκτορ από το μηχάνημα ή της κυρίας πρίζας , πρέπει να πιάσουμε το πλαστικό μέρος και όχι το καλώδιο.



Nessuna parte di questa pubblicazione può essere riprodotta con processo meccanico, fotografico o elettronico, nè sotto forma di registrazione fonografica, nè può essere memorizzata in un sistema di salvataggio, trasmessa o in altro modo copiata per uso pubblico o privato, senza l'autorizzazione di **NAMCO EUROPE LIMITED**.

Le informazioni contenute in questo manuale sono state date in buona fede ed erano accurate al momento della pubblicazione. Tuttavia NAMCO EUROPE LIMITED, si riserva il diritto di apporre cambiamenti e variazioni senza alcun preavviso.

Questo apparecchio è stato costruito in conformità alle Direttive della Comunità Europea, ed è stato provato e soddisfa le Direttive 89/336/EEC e 72/23/EEC per l'applicazione degli standards delle norme EN55014-1, EN55014-2 e EN60335-2-82 (vedi fronte del manuale), e per questo porta il marchio CE. Qualsiasi cambiamento o modifica di questo apparecchio deve essere in conformità con le Direttive della Comunità Europea.

In caso di condizioni di estrema interferenza dall'esterno, per esempio trasmissioni radio, scariche elettrostatiche o transistori sulla linea, può verificarsi un decadimento delle prestazioni. Comunque l'apparecchio ritornerà al rendimento normale quando la sorgente dell'interferenza avrà cessato di emettere o sarà stata rimossa.

Nota bene: se il processore del gioco "resetta" a causa di una interruzione o diminuzione del voltaggio di linea, un eventuale credito, già concesso, può essere annullato.

Questo gioco non è una macchina così come viene definita dalla Direttiva Macchine 89/392/EEC.

AVVERTENZE PER LA SICUREZZA

Allo scopo di usare questo apparecchio in sicurezza, leggere questo Manuale dell'operatore attentamente prima dell'installazione, regolazione o uso di questa macchina.

Tutte le volte che il proprietario di questo apparecchio affida lo smontaggio, l'installazione, la regolazione o la manutenzione ordinaria ad un'altra persona, il proprietario stesso deve assicurarsi che quella persona legga le precauzioni necessarie e i paragrafi importanti di questo manuale prima di iniziare a lavorare.

Perchè non succeda alcun incidente quando la macchina è operante, seguire rigorosamente le note sulla sicurezza come specificato più avanti.

Questo manuale insieme con il manuale di installazione (dove si può applicare) forma una parte integrante dell'apparecchio e deve essere disponibile sempre al personale operante e di servizio.

Questa macchina deve essere usata solo in interni e deve essere usata solo per gli scopi per cui è progettata.

Namco Europe Ltd non si assume responsabilità per incidenti, ferite o danni risultanti da cambiamenti non autorizzati o da uso improprio della macchina.

NOTE PER LA SICUREZZA

Le seguenti note sulla sicurezza sono usate dal principio alla fine di questo manuale. Valutare attentamente ciascuna di queste note ed il loro significato prima di installare, fare assistenza o regolazioni su questa macchina.

WARNING | "Warning" evidenzia un rischio di ferita o di morte. Non procedere oltre una nota "Warning" finchè le avvertenze specificate non siano completamente capite e conosciute.

CAUTION ⓘ "Caution" evidenzia un rischio di danneggiare la macchina. Non procedere oltre una nota "Caution" finchè le avvertenze specificate non siano completamente capite e conosciute.

CONSIDERAZIONI GENERALI SULLA SICUREZZA

- | **Mettere in funzione l'apparecchio solo dopo aver controllato che l'installazione sia stata effettuata correttamente ed in conformità alle istruzioni del manuale.**
- | **Gli avvisi "Warning" devono sempre essere conservati in buone condizioni e sostituiti se consumati, cosicché il cliente li possa leggere chiaramente.**
- | **Se vi sono errori o problemi con la macchina, si deve interrompere il funzionamento immediatamente e risolvere il problema prima di ogni ulteriore uso.**
- | **L'installazione, l'assistenza, le regolazioni e la manutenzione ordinaria devono essere eseguite solo da persone idonee e qualificate.**
- | **Per una protezione costante contro il rischio di fuoco, assicurarsi che i fusibili sulle alimentazioni siano solo sostituiti con lo stesso tipo e caratteristiche. L'uso di altri fusibili o materiali è proibito.**
- | **Per prevenire possibili scosse elettriche dovute a difetti, questa macchina DEVE essere installata con un connettore sicuramente MESSO A TERRA.**
- | **In caso il cavo di alimentazione di rete risultasse danneggiato deve essere sostituito immediatamente.**
- | **Non accendere la macchina finchè la stessa non è stata installata completamente e correttamente.**
- | ⓘ **Prima di collegare la macchina alla rete, assicurarsi che la macchina sia preparata per il voltaggio corretto e che siano inseriti i fusibili adatti.**

NOTES D'INSTALLATION

- | **NON ACCENDERE MAI** la macchina finchè l'installazione non è stata completata.
- | Allo scopo di prevenire possibili scosse elettriche, la macchina deve essere obbligatoriamente collegata alla rete con un connettore messo a terra con connessioni sicure.
- | **i** Per evitare danni alla macchina durante la messa in opera, assicurarsi che il voltaggio della rete sia 230 volts AC.
- Note: Il luogo di destinazione della macchina deve avere il pavimento liscio e si raccomanda di sistemare dei cuscinetti di gomma sotto i piedini di livellamento per prevenire lo scivolamento della macchina sul pavimento.
- Note: Per garantire l'accesso all'alimentatore e alla scheda madre, assicurarsi che il retro del mobile principale sia separato dalla parete o da altre macchine di almeno 500mm.

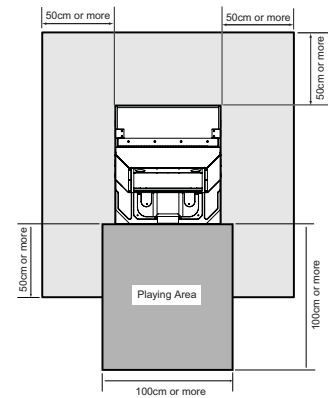

- | Il gioco è fornito di ruote per rendere più facile il suo spostamento. Fare attenzione quando si muove la macchina su una superficie inclinata.
- | L'altezza totale della parte principale è 1915mm, fare attenzione ad eventuali ostacoli sopra la testata ovvero ad eventuali installazioni di luci.

RIMOZIONE E SOSTITUZIONE DI GRUPPI E PARTI STACCATE

- | L'installazione, l'assistenza, le regolazioni e la manutenzione ordinaria devono essere eseguite solo da persone idonee e qualificate.
- | Non apporre alcuna modifica alla macchina senza autorizzazione preventiva. Il fare questo può causare un pericolo non prevedibile.
- | Quando si rimpiazza o si riparano delle parti (incluse le viti) si possono usare solo parti approvate dalla Namco Europe Ltd.
- | Assicurarsi che la macchina sia SPENTA prima di incominciare qualsiasi lavoro di manutenzione (guasti, riparazioni etc.)
- | Se state per iniziare un lavoro non descritto in questo manuale, contattate il vostro distributore per istruzioni poichè non si accetta alcuna responsabilità per danni o ferite.
- | Parti dell'alimentatore e del monitor rimangono caldi o portano alta tensione anche dopo aver spento l'apparecchiatura e possono causare bruciature o scosse elettriche. Attenzione a non toccare queste parti accidentalmente.
- | Assicurarsi che la macchina abbia l'interruttore nella posizione OFF prima di inserire o disinserire qualsiasi connettore o spina.
- | Quando vengono rimossi i connettori principali dalla macchina oppure la spina dell'alimentazione dalla parete bisogna sempre afferrare il connettore e non il cavo.



Ingen del av denne utgivelsen må reproduseres av noen mekaniske, fotografiske eller elektroniske prosesser, eller i form av fotografiske opptak, og ikke kan det lagres i et gjenvinnbart system, sendt eller kopiert for offentlig eller privat bruk, uten tillatelse fra NAMCO EUROPE LIMITED.

Da informasjonen i denne manualen er gitt i god tru og var korrekt da den ble utgitt, tillegger NAMCO EUROP LIMITED seg retten til å lage forandringer uten varsel.

Denne maskinen er produsert i samsvar med direktiver framsatt av det Europeiske samfunn. Maskinen er testet og samsvarer med direktivene 89/336/EEC og 72/23/eec med anvendelse av EN55014-1, EN55014-2 og EN60335-2-82 standarder (se i begynnelsen av manualen), og derfor bærer CE merket. Hvilken som helst forandring eller modifisering må skje etter direktivene satt av det Europeiske samfunn. Uautoriserte forandringer på dette produktet, kan motstride disse direktivene.

Under noen forhold av ekstreme ytre forstyrrelser, f.eks radio sendere, elektronisk utladning eller transiente spenninger, kan man regne med noe senket ytelse. Men maskinen vil oppnå normal ytelse når kilden til forstyrrelsene opphører eller er fysisk fjernet.

Merk:- Hvis spilllets prosessor resettes p.g.a et kutt eller reduksjon av hovedspenningen kan oppsparte kreditt på spillet forsvinne.

Dette spillet er ikke en maskin som er definert ved Maskin direktivet 89/392/EEC.

Sikkerhets advarsel.

For å bruke denne maskinen uten noe form for fare, sørg for å lese denne manualen nøye før installasjon, justeringer eller bruk av maskinen.

Når eieren av denne maskinen overlater avmontering, installasjon, justering eller rutine vedlikehold til en annen person, skal eieren forsikre seg om at denne personen leser de passende forsiktighetsreglene og relevante deler av manualen før han starter på arbeidet.

For å forhindre at ulykker inntreffer når maskinen er i drift, følg strengt teksten om sikkerhet som beskrevet nedenfor.

Denne manualen sammen med installasjons manualen (hvor det er anvendelig) er en intrigert del av utstyret og må være tilgjengelig for drift- og servispersonell til alle tider.

Denne maskinen er bare for innendørs bruk og skal bare benyttes etter mente hensikter.

Namco Ltd. bærer intet ansvar ved ulykker, kvestelse eller skade som følge av uautoriserte forandringer, eller for uriktig bruk av maskinen.

Sikkerhets beskjeder.

Følgende sikkerhets punkter er brukt ut denne manualen. Gjør deg kjent med disse punktene og deres mening før installasjon, service eller du utfører noen innstillinger på denne maskinen.

ADVARSEL | Advarsel innebærer en risiko som kan føre til kvestelse eller død. Ikke fortsett utover advarslen før den er ordentlig forstått og mottiltak er igangsatt.

FORSIKTIG ⓘ Forsiktig innebærer en risiko som kan medføre skade på maskinen. Ikke fortsett utover advarslen før den er ordentlig forstått og mottiltak er igangsatt.

VANLIGE SIKKERHETSTILTAK

- | **Bruk bare denne maskinen etter å ha kontrollert at den er korrekt installert ifølge manualen.**
- | **Advarsel skiltene må bestandig holdes i skikket stand og eventuelt byttes ut hvis det oppstår skade på dem, slik at kunden uten vanskelighet kan lese dem.**
- | **Hvis det er en feil eller et problem med maskinen, må den straks settes ut av funksjon. Og må under ingen omstendigheter startes før problemet er rettet på.**
- | **Installasjon, service, justering eller rutine vedlikehold skal bare utføres av kvalifiserte personer.**
- | **For fortsatt beskyttelse mot brann, forsikre deg at hoved sikringen bare byttes ut med en av samme type og verdi. Bruk av andre sikringer eller materiale er forbudt.**
- | **For å forhindre mulige elektriske sjokk grunnet funksjonsfeil, må denne maskinen være ordentlig jordnet.**
- | **Hvis ledningen til hoved strømforsyningen skades må den straks byttes ut.**
- | **Ikke slå på maskinen før den er korrekt installert.**

ⓘ Før du kople maskinen til strømmettet, forsikre deg om at maskinen innstilt for den korrekte spenningen og de riktige sikringene benyttes.

MERKNADER VED INSTALLASJON

- | Slå ALDRI på maskinens strømforsyning før installasjonen er fullført.
- | For å forhindre eventuelle elektriske sjokk, forsikre deg om at maskinen er koplet til et strømnnett med ordentlig jording.
- ⓘ For å forhindre skade på maskinen p.g.a. feil bruk, sørg for at spenningen til hoved strømforsyningen er 230Volt AC.

MERKNADER: Hvis plassen hvor spillet skal plasseres har polerte gulv anbefales det at du benytter gummi sko under nivå justeringene, for å forhindre at maskinen kan flytte på seg.

MERKNADER: For å få adgang til strømforsyningen og CPU-kort, forsikre deg om at bakparten av hoved kabinettet er skilt fra vegger eller andre maskiner med minst 500mm.

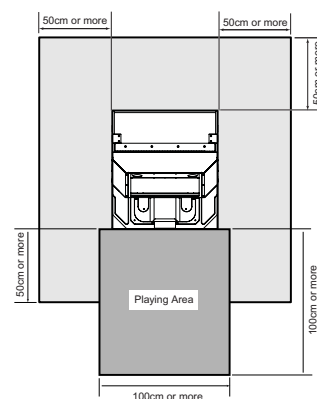

- | Spillet har montert hjul for å gjøre det letter å flytte på. Hver forsiktig når det skal flyttes på en hellende overflate.
- | Den totale høyden på hoved enheten er 1915mm. vær forsiktig med høye hindringer som f.eks lysrør.

FJERNE OG UTSKIFTE ENHETER OG DELER.



Installasjon, service, justering eller rutine vedlikehold skal bare utføres av kvalifiserte personer.

- | Ikke lag noen forandringer på denne maskinen uten godkjenning. Dette kan medføre uforutsette farer.
- | Bare deler spesifisert av Namco Europe Ltd. skal benyttes ved utskifting eller reparasjon av deler (dette gjelder også skruer).
- | Forsikre deg om at strømmen er slått av før du påbegynner noe som helst vedlikeholdsarbeid (feilsøking, reparasjon osv.)
- | Hvis du utfører arbeid som ikke er beskrevet i denne manualen, ta kontakt med din distributør for instruksjon da ikke noe ansvar vill bli akseptert for skade på maskin eller på personer.
- | Deler av strømforsyningen og monitoren er fortsatt varm eller bærer høye spenninger selv etter strømmen er slått av og kan forsaake skader eller elektriske sjokk. Forsikre deg om at du ikke berører disse delene.
- | Forsikre deg om at maskinen er slått av før du kopler sammen eller tar fra hverandre plugger eller koplinger.
- | Når du fjerner hoved koplignene fra maskinen, eller hoved pluggen fra støpselet, ta bestandig tak i pluggen og ikke ledningen.



Niets uit deze publikatie mag worden gereproduceerd door enig mechanisch, fotografisch of elektronisch proces, of in de vorm van een fonografische opname, noch mag het opgeslagen worden in een retrieval systeem, doorgezonden of anderszins gekopieerd voor publiek of privégebruik, zonder toestemming van Namco Europe Limited.

Ofschoon de informatie in deze handleiding in goed vertrouwen is gegeven en nauwkeurig was ten tijde van het drukken, houdt Namco zich het recht voor om veranderingen en aanpassingen te maken zonder bericht.

Deze machine is geproduceerd volgens Richtlijnen van de Europese Gemeenschap, en is getest en is in overeenstemming met de Richtlijnen 89/336/EEC en 72/23/EEC door de toepassing van de standaards EN55014-1, EN55014-2 en EN60335-2-82 (zie voorin de handleiding) en draagt als zodanig het CE-merk. Enige veranderingen of aanpassingen aan deze machine dienen in overeenstemming te zijn met de Richtlijnen van de Europese Gemeenschap. Enige ongeautoriseerde veranderingen aan dit produkt kunnen in strijd zijn met deze Richtlijnen.

Onder sommige omstandigheden van extreme externe storingen, bijv. radiotransmissies, electrostatische ontladingen of pieken op het net, kan prestatieterruggang optreden. De machine zal echter normaal presteren zodra de storingsbron gestopt of verwijderd is.

Let op: - als de spelprocessor reset a.g.v. een onderbreking of vermindering van de netstroom, dan kunnen opgebouwde credits verloren gaan.

Dit spel is niet een machine zoals omschreven in de Machinery Directive 89/392/EEC.

Veiligheidsopmerkingen

Om deze machine veilig te kunnen gebruiken, dient vóór installatie, aanpassing of gebruik van deze machine, de Bedieningshandleiding zorgvuldig gelezen te worden.

Telkens wanneer de eigenaar van deze machine de demontage, installatie, aanpassing of routine-onderhoud toevertrouwd aan een andere persoon, dient de eigenaar er voor te zorgen dat deze persoon de juiste voorzorgsmaatregelen en relevante gedeeltes uit de handleiding leest voordat hij begint.

Om er voor te zorgen dat geen ongelukken gebeuren als de machine gebruikt wordt, dienen onderstaande veiligheidsaanwijzingen zorgvuldig opgevolgd te worden.

Deze handleiding maakt samen met de installatiehandleiding (waar van toepassing) een integraal deel uit van de apparatuur en moet te allen tijde ter beschikking staan van exploitatie- en onderhoudspersoneel.

Deze machine is alleen bedoeld voor gebruik binnenshuis en dient alleen gebruikt te worden voor bedoelde doeleinden.

Namco Ltd. is niet verantwoordelijk voor ongelukken, letsel of schade die voortkomt uit ongeoorloofde veranderingen aan of onjuist gebruik van deze machine.

Veiligheidsopmerkingen

De volgende veiligheidsopmerkingen worden overal in deze handleiding gebruikt. Maak uzelf vertrouwd met deze opmerkingen en hun betekenis vóór installatie, het plegen van onderhoud of het aanbrengen van aanpassingen aan deze machine.

WAARSCHUWING | **Waarschuwing geeft een gevaar aan dat zou kunnen resulteren in letsel of de dood. Ga niet verder dan een waarschuwingsofmerking totdat de aangegeven omstandigheden volledig begrepen zijn en hieraan voldaan is.**

VOORZICHTIG ⓘ **Voorzichtig geeft een gevaar aan dat zou kunnen resulteren in schade aan de machine. Ga niet verder dan een voorzichtigheidsopmerking totdat de aangegeven omstandigheden volledig begrepen zijn en hieraan voldaan is**

ALGEMENE VEILIGHEIDSOVERWEGINGEN

- | **Stel deze machine alleen in gebruik nadat gecontroleerd is of de machine correct en overeenkomstig de handleiding is geïnstalleerd.**
- | **De waarschuwingstickers dienen altijd in goede staat te worden gehouden en vervangen indien versleten, zodat de klant ze goed kan lezen.**
- | **Als zich een fout of probleem voordoet met de machine, dan dient de machine onmiddellijk stopgezet en het probleem verholpen te worden voordat de machine verder gebruikt wordt.**
- | **Installatie, service, aanpassingen of routine-onderhoud dient alleen uitgevoerd te worden door hierin bekwame personen.**
- | **Om blijvende bescherming tegen brandgevaar te garanderen, dient ervoor gezorgd te worden dat de netzekeringen alleen vervangen worden door zekeringen van hetzelfde type en dezelfde sterkte. het gebruik van andere zekeringen of ander materiaal is verboden.**
- | **Om mogelijke elektrische schokken a.g.v. storingen te voorkomen, MOET deze machine voorzien zijn van een goed vastzittende aardstekker.**
- | **Mocht het netsnoer op enig moment beschadigd worden, dan moet deze onmiddellijk vervangen worden.**
- | **Zet de machine niet AAN totdat deze correct is geïnstalleerd.**

ⓘ Voordat de machine op het lichtnet wordt aangesloten, dient gecontroleerd te worden of de machine op het correcte voltage staat afgesteld en of de correcte zekeringen zijn aangebracht.

Opmerkingen aangaande Installatie

| **Sluit de machine nooit aan op de stroomtoevoer totdat de installatie is voltooid.**

| Om mogelijke elektrische schokken te voorkomen, dient ervoor gezorgd te worden dat de machine middels een goed vastzittende aardstekker op het lichtnet is aangesloten.

ⓘ Om schade aan de machine door verkeerd gebruik te voorkomen, dient ervoor gezorgd te worden dat het voltage van het lichtnet 230volts AC bedraagt.

OPMERKING: Als de machine op een gladde ondergrond wordt gebruikt, is het raadzaam rubber matjes onder de stelvoetjes te bevestigen om te voorkomen dat de machine over de vloer gaat glijden.

OPMERKING: Om toegang te krijgen tot de voeding- en de CPU-assemblies, dient ervoor gezorgd te worden dat de achterkant van het kabinet minimaal 500mm verwijderd is van de muur of andere machines.

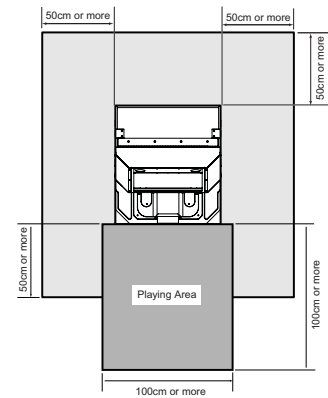

| **Het spel is voorzien van wielletjes, waardoor het gemakkelijker is om te verplaatsen. Wees voorzichtig als de machine op een hellend vlak gereden wordt.**

| **De hoogte van het hoofdgedeelte is 1915mm: kijk dus uit voor obstakels zoals lampen.**

Verwijderen en vervangen van Assemblies en onderdelen

| **Installatie, service, aanpassingen of routine-onderhoud dient alleen uitgevoerd te worden door hierin bekwame personen.**

| **Maak geen veranderingen aan deze machine zonder goedkeuring vooraf. Dit kan onvoorzien gevaar opleveren.**

| **Alleen onderdelen die door Namco Europe Ltd. zijn gespecificeerd dienen gebruikt te worden bij het vervangen of repareren van onderdelen (incl. schroeven).**

| **Zorg ervoor dat de machine UITgeschakeld is voordat er enig onderhoudswerk wordt verricht (troubleshooting, reparaties etc.)**

| **Bij het verrichten van werkzaamheden die niet in deze handleiding staan beschreven, dient voor instructies altijd contact opgenomen te worden met de verdeler aangezien geen verantwoording wordt genomen voor schade of letsel.**

| **Delen van de voeding en de monitor blijven warm of behouden hoogspanning zelfs nadat de machine UITgeschakeld is en zouden verbrandingen of elektrische schokken kunnen veroorzaken. Ben voorzichtig en raak deze delen niet per ongeluk aan.**

| **Zorg ervoor dat de machine is UITgeschakeld voordat pluggen of connectors ingestoken of uitgetrokken worden.**

| **Als het netsnoer uit de machine of uit het stopcontact verwijderd wordt, dient altijd de stekker vastgepakt te worden en niet het snoer.**



Nenhuma parte desta publicação poderá ser reproduzida por processos mecanográficos, fotográficos, electrónicos ou ainda sob a forma de gravação sonora nem tão pouco poderá ser gravada através de sistemas informáticos transmissíveis ou de outra forma copiados para uso publico ou privado sem autorização expressa da NAMCO EUROPA LIMITADA.

A informação contida neste manual foi fornecida de boa fé, sendo rigorosa na altura da sua publicação. A NAMCO EUROPA LIMITADA, reserva-se o direito de proceder a mudanças e alterações sem qualquer aviso prévio.

Esta maquina foi fabricada de acordo com as Directivas Comunitárias Europeias e tem sido testada em conformidade com as seguintes Directivas: 89/336/EEC e 72/23/EEC através dos requerimentos normativos, EN55014-1, EN55014-2 e EN60335-2-82 (ver capa frontal do manual) e como tal sustenta o certificado de marca de CE. Quaisquieres alterações ou modificações efectuadas nesta maquina deverão ser em conformidade com as Directivas da Comunidade Europeia. Quaisquier alterações não autorizadas a este equipamento poderão infringir tais Directivas.

O funcionamento normal desta maquina, poderá ser afectado debaixo de algumas condições extremas de interferências externas tais como; transmissões via radio, descargas electroestáticas e passagens de corrente na rede de alimentação. Contudo o seu funcionamento normal será restabelecido logo que a fonte de interferências tenha cessado ou tenha sido neutralizada.

Nota :- Se o processador de jogo for inicializado devido a uma interrupção ou quebra da corrente principal, quaisquer creditos obtidos poderão desaparecer.

Este jogo por si só não constitui uma maquina tal como definido pelas Directivas de Maquinaria de 89/392/EEC8.

AVISOS DE SEGURANÇA

Afim de usar esta maquina com segurança, certifique-se que lê este manual de operador atentamente antes de proceder á montagem e afinação ou uso da mesma.

Sempre que o proprietário desta maquina confiar a desmontagem, instalação, afinação ou manutenção preventiva da mesma a outra pessoa, deverá este assegurar - se que a pessoa em questão lê as precauções apropriadas e capitulos relevantes deste manual antes de iniciar o trabalho.

Afim de evitar qualquer tipo de acidente quando a maquina estiver em funcionamento, deverá seguir rigorosamente os procedimentos de segurança descritos abaixo.

Este manual juntamente com o manual de instalação (aonde aplicavel), constituem parte integrante do equipamento e deverão estar sempre disponiveis ao operador e pessoal tecnico de assistência.

Esta maquina destina-se a ser operada em espaços interiores apenas e a sua utilização deve circunscrever-se somente aos fins previstos.

A Namco Ltd. declina qualquer responsabilidade por acidentes, ferimentos ou danos resultantes de modificações não autorizadas ou uso indevido desta maquina.

AVISOS DE SEGURANÇA

Os seguintes avisos de segurança são usados através de todo o manual. Familiarize-se com cada um destes avisos e respectivos significados antes de instalar, assistir ou efectuar qualquer afinação nesta maquina.

PERIGO | Perigo revela uma situação anormal que poderá resultar em ferimentos ou morte. Não avance para além de um aviso de Perigo sem que todas as condições indicadas estejam completamente esclarecidas e resolvidas.

CAUTELA ⓘ Cautela revela uma situação anormal que poderá resultar em danos materiais para a maquina. Não avance para além de um aviso de Cautela sem que todas as condições indicadas estejam completamente esclarecidas e resolvidas.

AVISOS DE PERIGO

| Esta maquina só deverá ser colocada em funcionamento após ter sido verificado que se encontra instalada correctamente e de acordo com o manual de instruções.

| Os avisos de perigo devem ser sempre mantidos em boas condições de leitura de forma a permitir uma leitura clara por parte do utilizador, caso se encontrem danificados deverão ser substituídos.

| Caso esta maquina manifeste algum erro ou problema durante o seu funcionamento, deverá ser imediatamente parada até que o problema em questão seja rectificado.

| A montagem, assistência e afinações ou manutenção de rotina desta maquina, deverão ser somente executadas por tecnicos ou pessoas devidamente qualificadas para o efeito.

| Afim de garantir uma protecção anti - fogo permanente nesta maquina, certifique-se que os fusíveis de protecção são sempre substituídos por fusíveis de igual valor ou calibre aos de origem. O uso de outro tipo de fusíveis ou material é proibido.

| Esta maquina deve estar sempre equipada com uma ficha com circuito de protecção à Terra, afim de evitar possiveis choques electricos, caso surja uma falha no sistema.

| Se a qualquer altura o cabo de alimentação principal ficar danificado, deverá ser imediatamente substituído.

| Não ligar a maquina sem que esta tenha sido correctamente instalada.

ⓘ Antes de ligar a maquina à tomada da rede de alimentação principal, certifique-se de que a maquina está preparada para a voltagem correspondente e de que também se encontra protegida com os fusíveis apropriados.

NOTAS SOBRE A INSTALAÇÃO

- | **NUNCA** ligar a maquina sem que a instalação esteja completamente finalizada.
- | Afim de evitar possiveis choques electricos, certifique-se que a maquina está ligada à rede de alimentação com uma ficha protegida com circuito de terra.
- | **i** Afim de evitar danos na maquina causados por falhas de operação, certifique-se que a voltagem da rede de alimentação principal é de 230volt AC.

NOTAS : Se esta maquina estiver colocada sobre um chão polido, recomenda-se a utilização de tapetes de borracha debaixo dos pés niveladores, afim de prevenir a maquina de deslizar no chão.

NOTAS : Quando precisar de aceder à fonte de alimentação e às placas (CPU), certifique-se que a parte trazeira do móvel central está separada da parede ou de outras maquinas pelo menos 500mm afim de ganhar espaço de manobra.

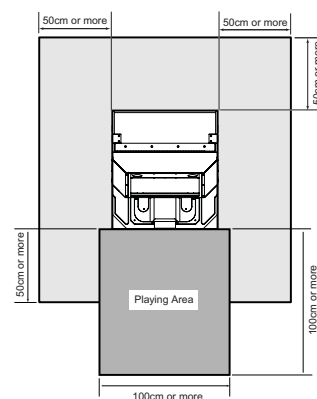

- | Esta maquina está equipada com rodas afim de facilitar a sua deslocação tenha cuidado ao mover a maquina num plano inclinado.
- | A altura total do bloco principal, é de 1915mm, tenha cuidado com qualquer tipo de obstruções existentes em altura como por exemplo; calhas electricas ou candeiros.

SUBSTITUIÇÃO E MONTAGEM DE PEÇAS

- | A montagem, assistência e afinações ou manutenção de rotina desta maquina, deverão ser somente executadas por tecnicos ou pessoas devidamente qualificadas para o efeito.
- | Não faça qualquer tipo de alteração prévia nesta maquina sem aprovação prévia. Se tal acontecer poderá provocar danos e perigos imprevisiveis.
- | A substituição ou reparação de peças deverá ser feita apenas com peças de origem ou especificadas pela "Namco Europa Ltd." (incluindo parafusos)
- | Certifique-se que a maquina se encontra desligada sempre que iniciar qualquer tipo de trabalho de manutenção. (identificação de avarias, reparação etc.)
- | Caso esteja a efectuar um trabalho não descrito neste manual, certifique-se que contacta o seu distribuidor para obter instruções, caso contrário não serão aceites responsabilidades por danos causados ou ferimentos.
- | Algumas zonas da fonte de alimentação e do monitor ficam quentes e transportam correntes de alta voltagem, mesmo depois de a maquina ter sido desligada, podendo causar queimaduras e choques electricos. Tome cuidado para não tocar acidentalmente estas zonas.
- | Certifique-se que a maquina está desligada antes de ligar ou desligar qualquer tipo de fichas ou junções.
- | Quando desligar a ficha principal da maquina ou a ficha do cabo de alimentação das tomadas da parede, deverá sempre agarrar na ficha e nunca puxar pelo cabo da mesma.



Ingen del av denna publikation får reproduceras, varken fotografiskt, elektroniskt eller i någon form av ljudinspelning. Det får inte heller lagras i något återvinningssystem, översändas eller på annat sätt kopieras för offentlig eller privat användning, utan tillstånd från NAMCO EUROPE LIMITED.

Eftersom informationen i denna manual lämnas ut i god tro och var korrekt när den trycktes, reserverar sig NAMCO EUROPE LIMITED för ändringar.

Denna maskin har tillverkats enligt direktiv från europeiska unionen, är testad och uppfyller direktiven enligt 89/336EEC och 72/23/EEC med tillämpning av EN55014-1, EN55014-2 och EN60335-2-82 standard (se manualens framsida) och bär därmed också CE-märket. Varje förändring eller modifiering av denna maskin måste ske i överensstämmelse med EU-direktiven. En förändring i denna produkt, som inte är auktoriserad, kan strida mot dessa direktiv.

Under vissa omständigheter när det gäller extrema externa störningar, t ex radiosändningar, elektrostatiska urladdningar eller nätburna strömstörningar, kan resultera i en något nedsatt funktion. Maskinen kommer dock att återgå till normal funktion, så snart störningen har upphört eller avlägsnats.

OBS! Om spelprocessorn startar om till följd av ett avbrott eller reducering av strömmen kan registrerade krediter gå förlorade.

Detta spel är inte en maskin enligt definitionen i Maskindirektivet 89/392/EEC

SÄKERHETS VARNING

För att maskinen ska kunna användas på ett säkert sätt, ska manualen läsas noggrant före installation, användning eller justering.

Om ägaren till maskinen anförtror någon annan person att montera isär, installera, justera maskinen eller utföra rutinunderhåll, ska ägaren försäkra sig om att denna person läser om försiktighetsåtgärder och tillämpliga delar av denna manual innan arbetet påbörjas.

För att förhindra att någon olycka händer när maskinen är igång, måste säkerhetspunkterna beskrivna nedan följas strikt.

Denna manual tillsammans med installationsmanualen (när tillämpligt) utgör en integrerad del av utrustningen och måste vara ständigt tillgänglig för operatörer och service personal.

Maskinen är avsedd för inomhusbruk och ska endast användas för detta ändamål.

Namco Ltd. bär inget ansvar för olyckor eller skador som orsakats av icke auktoriserade ändringar i maskinen eller felaktigt användande av densamma.

SÄKERHETSANVISNINGAR

Säkerhetsanvisningarna nedan används genomgående i manualen. Gör dig förtrogen med varje anvisning och dess innebörd innan installation, service eller justeringar görs på denna maskin.

VARNING | "Varning" anger en fara som skulle kunna skada eller förorsaka dödsfall. Fortsätt inte vid en sådan varningsanvisning innan de påvisade förhållandena är förstådda och åtgärdade i sin helhet.

OBSERVERA ⓘ "OBSERVERA" anger en fara som skulle kunna förorsaka skada på maskinen. Fortsätt inte vid en sådan varningsanvisning innan de påvisade förhållandena är förstådda och åtgärdade i sin helhet.

ALLMÄNNA SÄKERHETSBEAKTANDEN

- | Sätt inte igång maskinen utan att ha kontrollerat att den är korrekt installerad och i överensstämmelse med manualen.
- | Varningsanvisningarna måste alltid hållas i gott skick och ersättas när de blir slitna, så att kunderna kan läsa dem tydligt.
- | Om det uppstår fel eller problem med maskinen, måste användningen stoppas omedelbart och problemet rättas till innan den åter används.
- | Installation, service, justeringar eller rutinunderhåll ska endast utföras av en för ändamålet kvalificerad person.
- | För kontinuerligt skydd mot brandfara, ska man försäkra sig om att huvudsäkringarna endast ersätts med samma typ och specifikationer. Användandet av andra säkringar eller material är förbjuden.
- | För att förhindra en eventuell elektrisk stöt förorsakad av fel, MÅSTE maskinen vara försedd med säkert ansluten JORDAD kontakt.
- | Om strömförsörjningskabeln på något sätt skadas, måste den bytas ut omedelbart.
- | Vrid inte strömbrytaren till ON innan maskinen är korrekt installerad.

ⓘ Innan strömmen sätts på till maskinen, måste man försäkra sig om att den är inställd på rätt spänning och att rätt säkringar är isatta.

ATT BEAKTA VID INSTALLATION

- | Sätt aldrig på strömmen på maskinen innan installationen är klar.
- | För att förhindra elektriska chocker, försäkra dig om att maskinen kopplas till strömförsörjning med jordad kontakt
- | **i** För att undvika skador på maskinen p g a felaktigt handhavande, försäkra dig om att strömstyrkan är 230 volt AC.

OBSERVERA: Om maskinen är placerad på ett polerat golv, rekommenderas att placera gummibrickor under nivåjusteringen för att förhindra att maskinen glider på golvet.

OBSERVERA: För att kunna komma åt strömförsörjningen och CPU, se till att baksidan av huvudkabinettet är placerat minst 500 mm från vägg eller annan maskin.

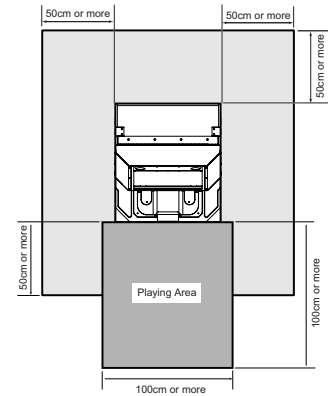

- | Spelet är försett med hjul för att underlätta förflyttningar. Var försiktig om spelet ska flyttas på en sluttande yta.
- | Den totala höjden är 1915 mm, tänk på eventuella högt placerade hinder, t ex lampor.

ATT TA BORT ELLER BYTA UT ENHETER OCH DELAR

- | Justeringar och underhåll på denna maskin skall endast utföras av kvalificerad personal.
- | Gör inga ändringar på denna maskin utan ett godkännande i förväg. Detta kan förorsaka oförutsägbar fara.
- | Endast delar som är specificerade av Namco Europe Ltd. ska användas vid utbyten eller reparation av delar (inklusive skruvar).
- | Försäkra dig om att strömmen är avstängd innan underhållsarbete påbörjas (felsökning, reparationer etc.)
- | Om arbete ska utföras som inte är beskrivet i denna manual, är det viktigt att kontakta återförsäljaren för instruktioner eftersom inget ansvar accepteras för åverkan eller personskador.
- | Delar av strömförsörjningen och monitorn är varma och strömbärande även efter strömmen stängts av och kan orsaka brännskador eller elektriska stötar.
- | Försäkra dig om att maskinen är avstängd innan kontakter sätts i eller tas ur.
- | När kontakten tas ur maskinen eller ur väggen, ta alltid tag i kontakten och inte i sladden.



Tästä julkaisusta ei saa ottaa missään muodossa kopioita yksityis- tai julkiseen käyttöön ilman **NAMCO EUROPE LIMITED**:in lupaa.

Tässä ohjekirjassa olevat tiedot pitävät julkaisuhetkellä paikkansa. NAMCO EUROPE LIMITED:illä on kuitenkin oikeus muutoksiin ilman erillistä ilmoitusta.

Tämä laite on valmistettu EC direktiivien mukaisesti. Se on testattu ja todettu noudattavan seuraavia direktiivejä: 89/336/EEC ja 72/23/EEC (EN55014-1, EN55014-2 ja EN 60335-2-82 standardit). Näin ollen tämä laite on varustettu CE-merkinnällä. Kaikki tähän laitteeseen kohdistetut muutokset on tehtävä EC- direktiivien mukaisesti. Mikä tahansa valtuuttamattoman huoltomiehen tekemä muutos voi olla direktiivien vastainen.

Laitteen toiminta voi häiriintyä määrättyissä olosuhteissa, jotka johtuvat äärimmäisistä ulkoisista sähköhäiriöistä, kuten radiolähetys, elektrostaattinen purkaus tai vahavirrasta syntynyt häiriö. Toiminta normalisoituu kuitenkin heti, kun ulkoinen sähköhäiriö on poistettu.

Huom.- Jos peliprosessori resetoituu sähkökatkoksen tai vastaavan johdosta, voivat kaikki pelivaraukset hävitä.

Tämä laite ei ole 89/392/EEC direktiivien mukainen kone.

Turvallisuusvaroitukset

Tämän laitteen turvallinen käyttö edellyttää käyttöohjekirjan huolellista lukemista ennen laitteen asennusta, säätöä tai käyttöä. Jos tämän laitteen omistaja antaa jollekin toiselle osapuolelle tehtäväksi purkaa, asentaa, säätää tai muuten huoltaa laitetta, on omistajan varmistettava siitä, että toinen osapuoli on lukenut ja ymmärtänyt käyttöohjekirjan oleelliset osat ennen työhön ryhtymistä.

Turvallisuusohjeita on seurattava tarkoin vahinkojen välttämiseksi laitteen ollessa käytössä .

Tämä ohje sekä mahdollinen asennusohje muodostavat laitteiston oleellisen osan ja on siksi aina oltava huolto- ja käyttöhenkilökunnan käytettävissä.

Tämä laite on tarkoitettu vain sisätiläkäyttöön. Sitä ei saa käyttää muihin tarkoituksiin.

Namco Ltd ei vastaa niistä onnettomuuksista, loukaantumista tai vahingoista, jotka johtuvat laitteeseen ilman Namco Ltd:n lupaa tehdyistä muutoksista laitteen väärästä käytöstä.

Turvallisuusohjeet

Tässä käyttöohjekirjassa on käytetty seuraavia turvallisuuteen liittyviä huomautuksia. Tutustu jokaiseen näistä. Älä asenna, huolla tai säädä laitteistoa, ennen kuin olet täysin ymmärtänyt mitä ne tarkoittavat.

VAARA | “Vaara” tarkoittaa uhkaa, joka voi johtaa loukkantumiseen tai kuolemaan, **Älä koskaan ohita Vaara-merkintää, ennenkuin ohjeissa esitetyt olosuhteet on ymmärretty täysin.**

VAROITUS ⓘ “Varoitus” tarkoittaa uhkaa, joka voi johtaa laitteen vioittumiseen. Älä koskaan ohita Vaara-merkintää, ennenkuin ohjeissa esitetyt olosuhteet on ymmärretty täysin.

YLEISET TURVALLISUUNÄKÖKODAT

- | Varmista, että laite on asennettu oikein ja ohjekirjan mukaisesti ennen käyttöönottoa.
- | Varoitustaulu on pidettävä hyvässä kunnossa. Jos ne ovat kuluneet, ne on ehdottomasti vaihdettava, jotta asiakkaalla olisi mahdollisuus lukea niitä selvästi.
- | Jos laitteeseen tulee vika tai ongelmia, on se pysäytettävä välittömästi ja ongelma selvitettävä ennen uutta käyttöönottoa.
- | Vain riittävän ammattipätevyuden omaava henkilö saa suorittaa asennus-, huolto-, säätö- tai muita laitteeseen kohdistuvia rutiinitoimenpiteitä.
- | Jotta palovaaraa ei syntyisi, saa pääsulakkeita vaihtaa vain samankokoisiin sulakkeisiin. Muiden sulakkeiden tai materiaalin käyttö on ehdottomasti kielletty.
- | Sähköiskujen välttämiseksi vikatapauksissa, laite on ehdottomasti kytkettävä maadoitetulla johdolla maadoitettuun pistorasiaan.
- | Vioittunut verkkojohto on välittömästi vaihdettava.
- | Älä kytke laitetta päälle, ennen kuin se on oikein asennettu.
- ⓘ Varmista ennen verkkoon kytkemistä, että virtalähteen jännitteen asetus on asetettu oikealle jännitteelle ja että siinä on oikeat sulakkeet.

ASENNUSHUOMIOITA

| **Älä koskaan kytke laitetta päälle ennen kuin asennus on suoritettu loppuun.**

| **Tämän laitteen virtalähde on kytkettävä maadoitetulla johdolla maadoitettuun pistorasiaan, jotta sähköiskun vaaraa ei olisi.**

ⓘ Varmista, että virtalähteen jännite on 230 V AC, jotta ei laite vioitu.

Huomio: Jos tämä laite sijoitetaan liukkaalle esim. vahatulle lattialle, suositellaan laitettavaksi kumityynyt säätöjalkoihin liikkumisen estämiseksi.

Huomio: Varmista, että takaosan taakse jää vähintään 500 mm tilaa, jotta virtalähteeseen ja CPU-korttiin pääsee käsiksi.

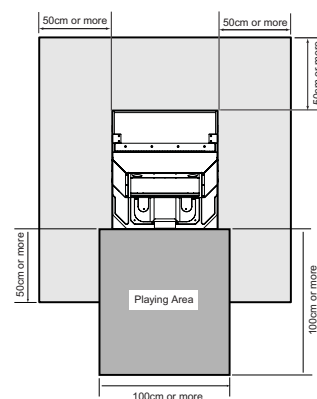

| **Laite on varustettu kääntyvillä pyörillä. Tämä on pidettävä mielessä, kun laitetta siirretään kaltevilla alustalla.**

| **Laitteen kokonaiskorkeus on yli 1915 mm. Varmista, ettei katossa ole esteitä. esim. valaisimia.**

| **Vain riittävän ammattipätevyyden omaava henkilö saa suorittaa asennus-, huolto-, säätö- tai muita laitteeseen kohdistuvia rutiinitoimenpiteitä.**

| **Tälle laitteelle ei saa tehdä mitään hyväksymättömiä muutoksia. Se voi aiheuttaa ennalta-arvaamattomia vaaroja.**

| **Vain Namco Europe Ltd:n määrittelemiä varaosia saa käyttää vaihtaessasi tai korjatessasi osia. (sisältäen ruuvit).**

| **Varmista, että laite on kytketty POIS PÄÄLTÄ ennen työn aloittamista.**

| **Ota yhteyttä maahantuojaan ohjeita varten, jos joudut tekemään työtehtäviä, joita ei ole esitelty huoltokirjassa, muuten vastuuta vioista tai loukkaantumisista ei ole.**

| **Virtalähde ja monitori pysyvät kuumina ja niissä on alueita, joissa on korkeajännite vaikka laite on kytketty pois päältä. Palovammojen tai sähköiskun saaminen on mahdollista. Älä koske näihin laitteisiin.**

| **Varmista, että laite on kytketty POIS PÄÄLTÄ ennen johtojen kytkemistä tai irrottamista.**

| **Irrottaessasi verkkojohdon seinästä tai laitteesta, ota kiinni itse pistokkeesta, ei johdosta.**

1. SPECIFICATIONS

POWER SUPPLY:- 230v / 190watts AC

AMBIENT OPERATING TEMPERATURE +5°C to +25°C

DIMENSIONS:-

Assembled 810(w) x 910(d) x 1895(h)
(Clearance Height with Playfield Door open: 1970mm)

Main Cabinet 810(w) x 910(d) x 1640(h)
Pop Header 530(w) x 60(d) x 255(h)

Dual Seat 825(w) x 405(d) x 540(h)

WEIGHT:-

Assembled 170kg

Main Cabinet 169kg
Pop Header 1kg

Dual Seat 9kg

COIN HOPPER CAPACITY:-

Coin Hopper (C) 10p Coins 700 coins
2p Coins 500 coins

Coin Hopper (L) 10p Coins 300 coins
2p Coins 300 coins

Coin Hopper (R) 10p Coins 300 coins
2p Coins 300 coins

ACCESSORIES:-

Keys: (Front Door) 2
(Back Door) 2

IEC Mains Lead 1

Operators Manual 1

QuadriBoss Data 1

Coin Ejection Pin 2

M5 Security Wrench 1

M6 Security Wrench 1

Buttonhead Screws (M5x16) 2

Whizznut (M5) 2

2. MAIN COMPONENTS

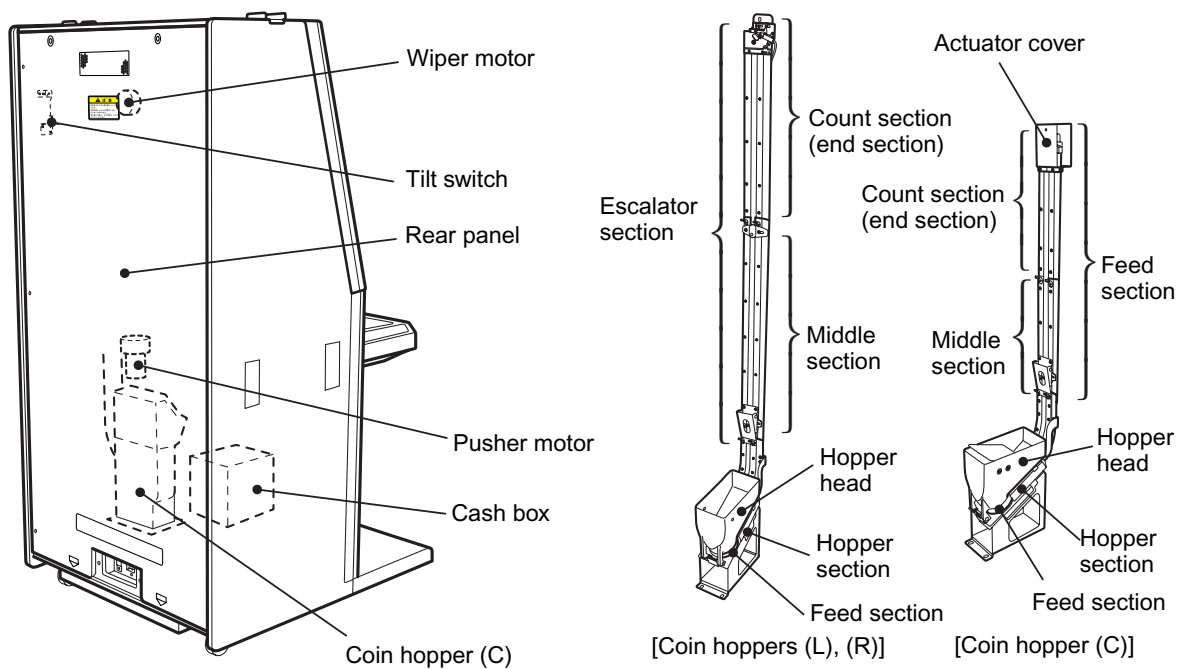
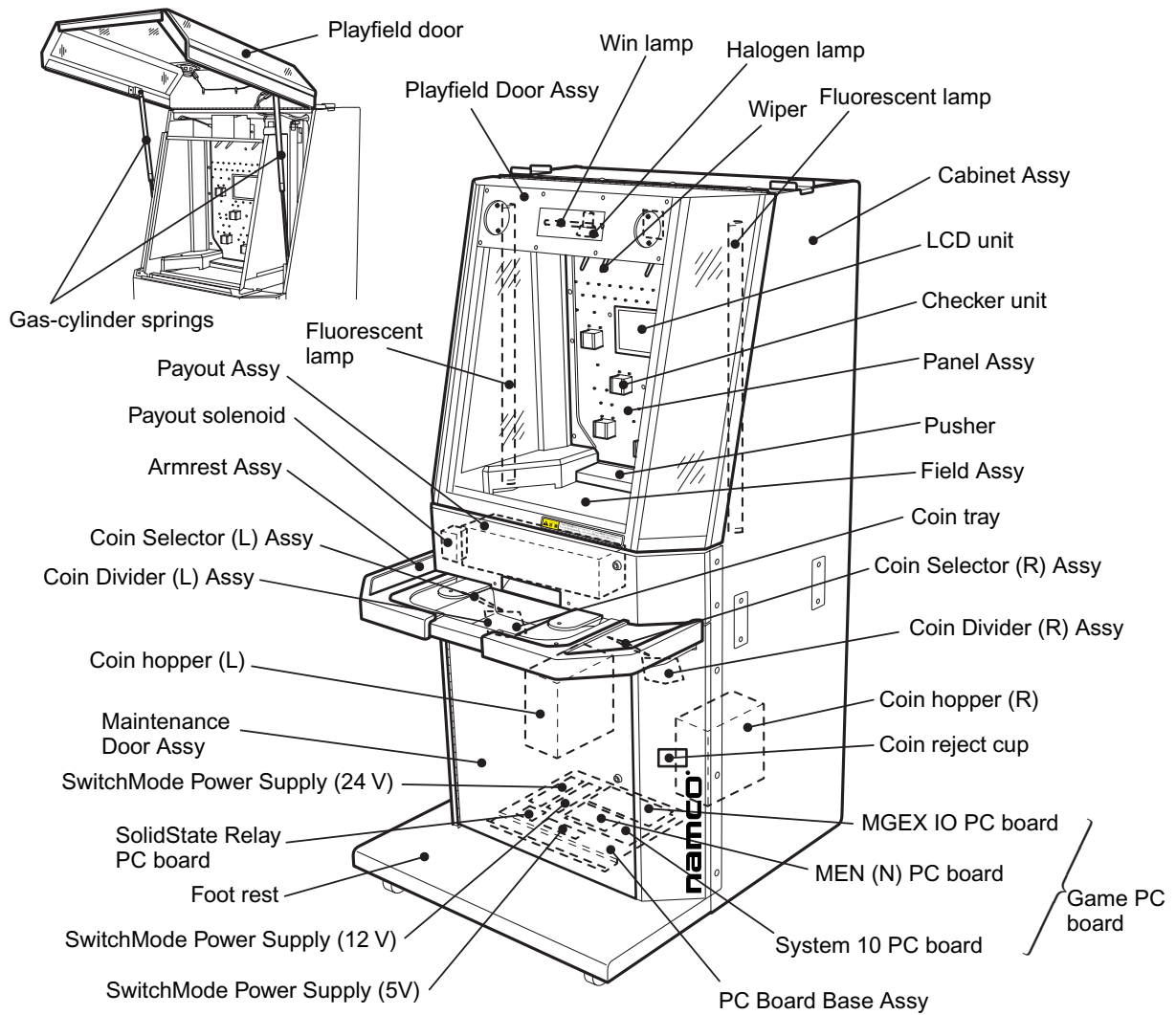

3. HOW TO PLAY

Basic Pusher

- Coins inserted by a player into a coin slot of the armrest section are counted by the coin sensor before falling into the coin hopper (L) or (R).
- The same number of coins counted are dispensed to the Panel Assembly from the coin hopper. These coins slide down the panel and fall onto the pusher table that is constantly moving backwards and forwards.
- Coins already on the pusher table are pushed forward by the fallen coins, and fall onto the playfield.
- Coins that fall onto the playfield are pushed by the pusher, forcing other coins on the playfield forwards. The pushed coins may move beyond the front edge of playfield and fall onto the coin tray, or fall into the slots located on either side of the playfield.
- The coins that have fallen onto the coin tray are returned to the player, while the coins entering the side slots are returned to the coin hopper (C).

PAC-MAN BALL

Basic rules

The player aims for dispensed coins to pass through the checkers located at seven positions on the Panel Assy. (Cherry, Peach, Orange, Melon, Grape, Pear and Pac-Man), to accumulate or delete balls on the screen.

When a coin passes through a checker, a ball corresponding to that checker is fired from the right side of the screen. At the same time, another ball is fired from the left side of the screen so that both balls hit each other in the centre of the screen.

Combo

When the two colliding balls are of the same type, it is a 'hit' and the balls disappear, and extra coins are dispensed to the pusher table.

When 'hits' are made consecutively within a preset time, a 'Combo' results, and the number of coins to be dispensed increases according to the number of 'Combos'.

Chain

When two colliding balls are different, the balls fall to the bottom of the screen and accumulate. When matching balls touch each other, a 'hit' results, and the balls disappear, and extra coins are dispensed to the pusher table. If there is a ball on top of the disappearing ball, it falls down. If the falling ball results in a 'hit', a 'Chain' occurs, and the number of coins to be dispensed increases according to the number of 'Chains'.

The maximum number of 'Chains' from the time of game shipment and the maximum number of 'Chains' since the current time of power on are displayed in the upper left corner of the screen.

Types of balls

Fruit ball	Linking two or more fruit balls of the same kind erases the ones on the ground.
Pac-Man ball	When it disappears in the air, the slot feature starts.
Wild ball	Matches any other ball it touches.
Jam ball	A useless ball that acts as a block.

Slot Event

- [~COINS] The number of coins displayed are dispensed onto the pusher table.
- [Clear~] All specified balls disappear from the balls accumulated at the bottom of the screen.
- [↓↓↓] New balls fall from the top
- [↑↑↑] New balls rise from the bottom.

4. INSTALLATION



This machine is designed for **INDOOR USE ONLY**.
Do not install in the following places.

1. Outdoors
2. Direct Sunlight, places with excessive humidity or dust, places where there is water leakage, near air-conditioning or heating equipment, places with excessive heat or cold temperature.
3. Places where it would be in the way of emergency exits or fire extinguishing equipment.
4. Unstable places or places with excessive vibration.
5. Places that are not level.
6. This machine must not be cleaned with a water jet, or installed in an area where a water jet could be used.



**DIESES GERÄT IST NUR FÜR DIE GEWERBLICHE AUFSTELLUNG IN
GESCHLOSSENEN RÄUMEN BESTIMMT.
DAS GERÄT DARF AN FOLGENDEN PLÄTZEN NICHT AUFGESTELLT WERDEN**

1. Im Freien.
2. In direktem Sonnenschein, an extrem feuchten und staubigen Plätzen, an Plätzen mit Wasseranschlüssen und möglichen Leckagen, nahe Klima- und Heizungsanlagen, an Plätzen mit extrem hohen oder niedrigen Temperaturen.
3. In der Nähe von Notausgängen oder Feuerlöschgeräten.
4. An unstablen Plätzen oder Plätzen mit übermäßiger Vibration.
5. An Plätzen, die nicht eben sind.
6. Diese Maschine darf nicht mit einem Wasserstrahl gereinigt oder in einem Bereich installiert werden, in dem Wasserstrahlen verwendet werden.



**DENNE MASKINE ER KUN DESIGNET TIL INDENDØRSBRUG
INSTALLER IKKE MASKINEN PÅ FØLGENDE STEDER**

1. Udendørs
2. Direkte sollys, steder med høj fugtighed el. støv, steder med vand udslip, i nærheden af air-condition eller varme udstyr, steder med usædvanlig høj el. kold temperatur.
3. Steder hvor den vil stå i vejen for nødudgange eller brandslukningsudstyr.
4. Ustabile steder eller steder med for store vibrationer.
5. Steder der ikke er plane.
6. Maskinen må ikke renses med en vandstråle eller monteres et sted hvor det er muligt at bruge en vandstråle.



**ESTA MÁQUINA ESTA DISEÑADA ÚNICAMENTE PARA USO EN INTERIORES. NO
INSTALE LA MÁQUINA EN LOS SIGUIENTES LUGARES.**

1. Exteriores.
2. Bajo luz solar directa, en lugares con polvo o humedad excesiva, lugares donde hay filtraciones de agua, cerca de aparatos de calefacción o de aire acondicionado, lugares con temperatura ambiente muy alta o muy baja.
3. Lugares donde la máquina obstruya salidas de emergencia o equipos de extinción de incendios.
4. Suelos inestables o lugares con vibraciones excesivas.
5. Lugares con suelos no nivelados.
6. Esta máquina no deberá ser lavada con agua a presión. Tampoco deberá instalarse en áreas donde puedan haber chorros de agua.



**CETTE MACHINE EST DESTINEE UNIQUEMENT A UN USAGE INTERIEUR
NE PAS INSTALLER LA MACHINE DANS LES ENDROITS SUIVANTS**

1. A l'extérieur.
2. Directement exposée au soleil, aux endroits excessivement humides ou poussiéreux, aux endroits où il y a des risques de fuite d'eau, près de ventilateurs ou source de chaleur, aux endroits très chauds ou froids.
3. Dans des zones de proximité des sorties de secours ou d'accès aux équipements d'extinction du feu.
4. Dans des emplacements instables ou soumis à de fortes vibrations.
5. Dans des endroits dénivelés.
6. Ne nettoyez pas cette machine sous un jet d'eau et ne l'installez pas à un endroit où l'on risque d'employer des jets d'eau.



**Το ΜΗΧΑΝΗΜΑ ΕΙΝΑΙ ΣΧΕΔΙΑΣΜΕΝΟ ΓΙΑ ΧΡΗΣΗ ΣΕ ΕΣΩΤΕΡΙΚΟ ΧΩΡΟ ΜΟΝΟ
ΜΗΝ ΤΟ ΠΟΘΕΤΗΣΕΤΕ ΤΟ ΜΗΧΑΝΗΜΑ ΣΤΑ ΕΥΣ ΑΚΑΛΟΘΕΥΣ ΧΩΡΕΥΣ**

1. Εξωτερικά
2. Απευθείας στον ήλιο, σε μέρη όπου υπάρχει υγρασία ή σκόνη, μέρη όπου υπάρχει άφθονο νερό, κοντά σε air-condition ή άλλου είδους θέρμανση, μέρη με υπερβολική υψηλή ή χαμηλή θερμοκρασία.
3. Σε μέρη όπου εμποδίζουν μέσα ανάγκης π.χ. πυροσβεστήρες ή άλλα.
4. Μη σταθερά μέρη ή μέρη με πολλούς κραδασμούς.
5. Μέρη που δεν είναι επίπεδα.



**QUESTA MACCHINA E' PROGETTATA PER ESSERE USATA ESCLUSIVAMENTE IN
AMBIENTI INTERNI.
NON INSTALLARE LA MACCHINA NEI SEGUENTI LUOGHI.**

1. In ambienti esterni.
2. Alla luce diretta del sole, in posti con eccessiva umidità o polvere, in luoghi dove ci siano infiltrazioni d'acqua, vicino ad apparecchi di condizionamento d'aria oppure riscaldamento, in posti eccessivamente caldi o freddi.
3. In luoghi dove potrebbe esserci un'uscita di emergenza o un'attrezzatura per lo spegnimento del fuoco.
4. In posti non stabili o con eccessive vibrazioni.
5. In luoghi non piani.
6. La macchina non deve essere pulita con un getto d'acqua, né installata in un'area in cui si utilizza un getto d'acqua.



**DENNE MASKINEN ER BARE KONSTRUERT FOR INNENDØRS BRUK
IKKE INSTALLER MASKINEN PÅ FØLGENDE Plasser.**

1. Utendørs
2. Konstant sollys, plasser med mye fuktighet og støv, plasser hvor det er vannlekasje, nære luft kjølere eller varme elementer, plasser med overdreven høy eller lav temperatur.
3. Plasser hvor det vill stå i veien for nødutganger eller brannslukking utstyr.
4. Ustabile plasser eller plasser med overdreven vibrasjon.
5. Plasser som ikke er i vater.
6. La macchina non deve essere pulita con un getto d'acqua, né installata in un'area in cui si utilizza un getto d'acqua.



**DEZE MACHINE IS ALLEEN VOOR GEBRUIK BINNENSHUIS ONTWORPEN
INSTALLEER DE MACHINE NIET OP DE VOLGENDE PLAATSEN**

1. Buiten
2. In direct zonlicht, op plaatsen met een zeer hoge vochtigheidsgraad of met veel stof, op plaatsen waar een waterlek is, dichtbij airco's of verwarmingsapparatuur, op plaatsen met een zeer hoge of koude temperatuur.
3. Op plaatsen waar nooduitgangen of blusapparatuur worden geblokkeerd.
4. Op onstabiele plaatsen of plaatsen waar grote trillingen voorkomen.
5. Op plaatsen die niet vlak zijn.
6. Deze machine mag niet gereinigd worden met een waterstraal of geïnstalleerd worden op een plaats waar een waterstraal gebruikt kan worden.



**ESTA MAQUINA FOI CONCEBIDA PARA UTILIZAÇÃO EM ESPACOS
INTERIORES APENAS
NÃO INSTALAR A MAQUINAS NOS SEGUINTE LOCAIS:-**

1. Exteriores.
2. Luz solar directa, locais com humidade excessiva ou pó, locais aonde existam fugas de água perto de ar condicionados ou equipamentos caloríficos e locais com temperaturas excessivamente quentes ou frias.
3. Locais aonde ficaria colocada no caminho de saidas de emergência ou equipamentos extintores de fogo.
4. Locais estruturalmente instáveis ou locais com vibrações excessivas.
5. Locais não nivelados.
6. Esta máquina não deve ser limpa com jato de água, ou instalada em área na qual possam ser usados jatos de água.



**DENNA MASKIN ÄR AVSEDD ENBART FÖR INOMHUSBRUK
INSTALLERA EJ MASKINEN PÅ FÖLJANDE STÄLLEN**

1. Utomhus
2. I direkt solsken, platser med extremt hög luftfuktighet eller damm, platser där det förekommer vattenläckage, nära luftkonditionering eller värmeelement, i extremt hög eller låg temperatur.
3. Platser där den skulle kunna vara i vägen för nödutgångar och brandsläckningsutrustning.
4. Instabila ställen eller där stark vibration förekommer.
5. Platser med nivåskillnad.
6. Denna maskin får inte rengöras med en vatten stråle, eller monterad inom ett område där en vatten stråle kan användas.



**TÄMÄ LAITE ON SUUNNITELTU VAIN SISÄKÄYTTÖÖN
ÄLÄ ASENNAA LAITETTA SEURAAVIIN PAIKKOIHIN:**

1. Ulkotilaan
2. Suoraan aurinkovaloon, kosteisiin tai pölyisiin paikkoihin, vesivuotopaikkojen läheisyyteen, ilmanvaihto- tai lämmityslaitteen lähistölle tai paikkoihin, jossa on erittäin kuumaa tai kylmää.
3. Varauoskäytävien, muiden pakoteiden tai tulensammutusvälineiden eteen.
4. Epävakaisiin tai täriseviin paikkoihin.
5. Kaltevalle alustalle.
6. Tätä laitetta ei saa pestä suihkuttamalla sille vettä eikä sijoittaa sellaiseen paikkaan, missä se voi joutua alltiiksi vesisuihkuille.

4-1 Notes on Installation

- | **WARNING** • **NEVER** turn the power to the machine **ON** until installation has been completed.
- | **WARNING** • In order to prevent possible electric shocks, be sure that the machine is connected to the mains with a securely connected earthed plug.
- ⓘ **CAUTION** • In order to avoid damage to the machine due to mis-operation, ensure that the voltage of the mains supply is 230volts AC.

- NOTE** • In order to gain access to the Power Supply and CPU assemblies, make sure that the rear of the machine is separated from a wall or other machine by at least 500mm.

4-2 Lowering the Level Adjusters

1. When the game is in it's final position, lower the four (4) level adjusters with a spanner, so that all castors are raised from the floor by approx 5mm. Tighten the lock nuts with a spanner to ensure that the Level Adjusters do not move.

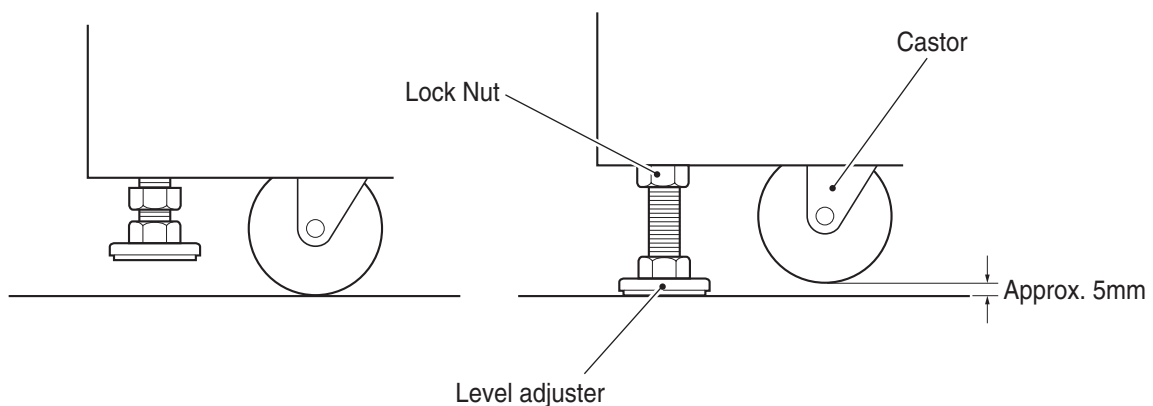

4-3 Adjusting the Tilt Sensitivity

The machine is equipped with a tilt device. If the machine is shaken excessively, the tilt device activates an alarm sound and closes the divider of the Payout Assy to prevent coins falling to the payout tray.

To reset the game after the tilt has been activated [see 5-3 page 46](#)

1. Remove 6 off pozihead screws (M4x30) and remove the Rear Door.
2. Loosen the grub screw (M3x6) on the weight, and slide the weight up or down to adjust the sensitivity. Moving the weight up will decrease sensitivity and moving the weight down will increase sensitivity. Re-tighten the grub screw (M3x6).
3. By loosening 2 off pozihead screws, the actuator bracket can be moved to ensure that the weight is central to the actuator.

If the actuator bracket cannot be adjusted so that the weight is central, the machine is not level. Adjust the level adjusters, ([see 4-2 page 36](#)), until the machine is level.

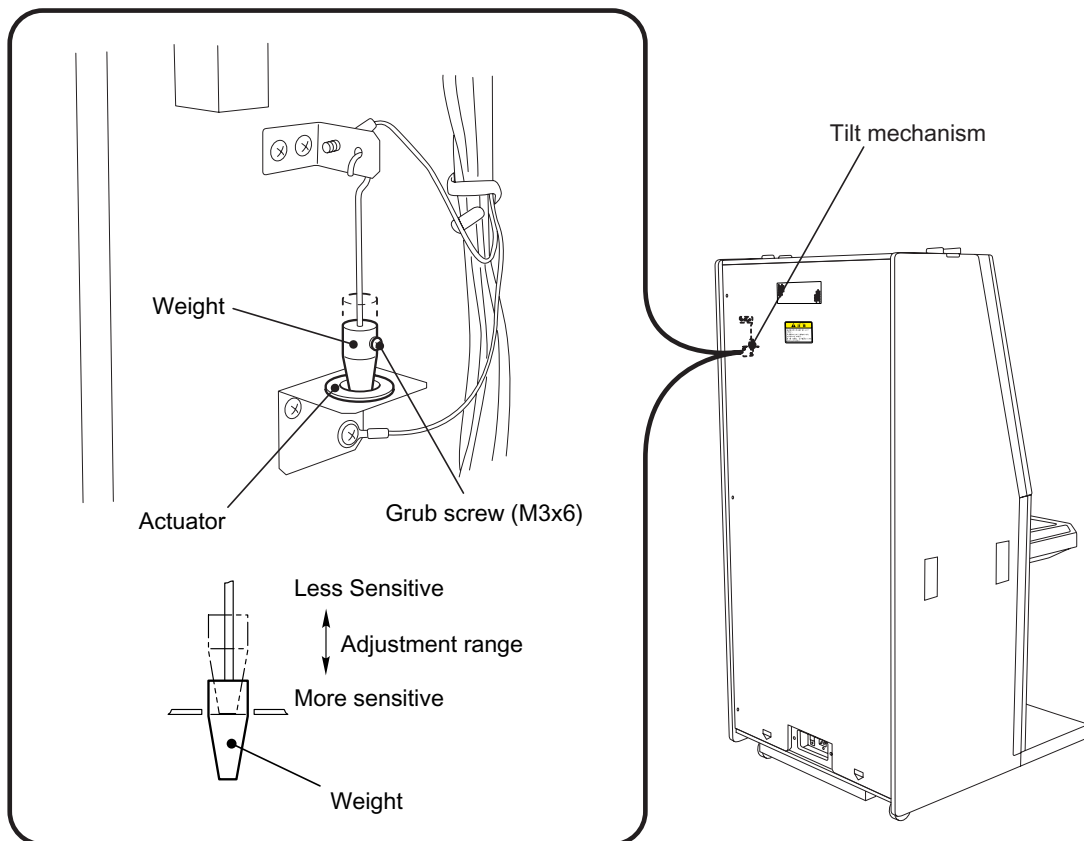

4-4 Loading with Coins

4-4-1 Loading Coin Hopper (C)

1. Unlock and open the playfield door, and drop coins through the coin inlet.
2. After loading the hopper (C) close and lock the playfield door.

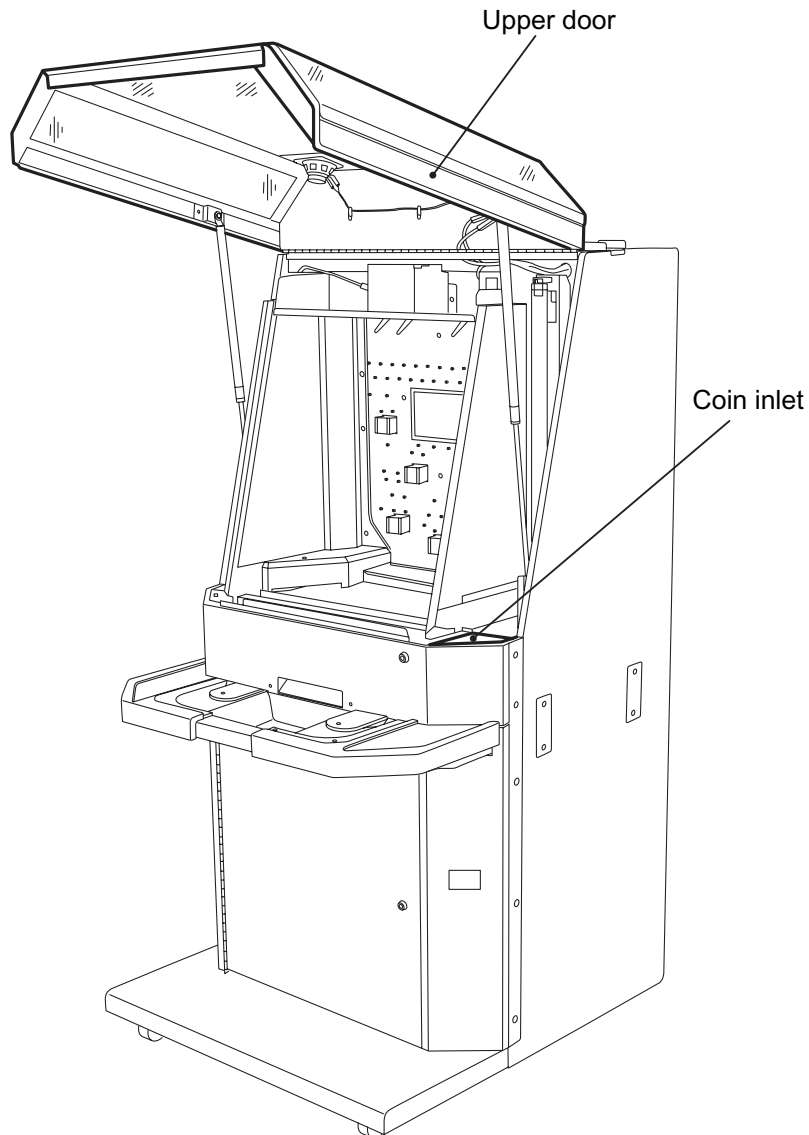

Note:

- The machine counts supplied coins only. Accurate H/G (house gain) cannot be obtained unless enough coins are supplied until coins start falling into the cashbox. Be sure to supply enough coins until coins start falling into the cashbox.
- The capacity of Coin Hopper (C) is approximately 700 x 10p coins and 500 x 2p coins.
- Do not use dirty, damaged or severely scratched coins, as they may cause coin jamming.

4-4-2 Loading Coin Hoppers (L) and (R)

1. Unlock and open the maintenance door, and supply coins directly to the coin hoppers (L) and (R).
2. After loading the hoppers (L) and (R) close and lock the maintenance door.

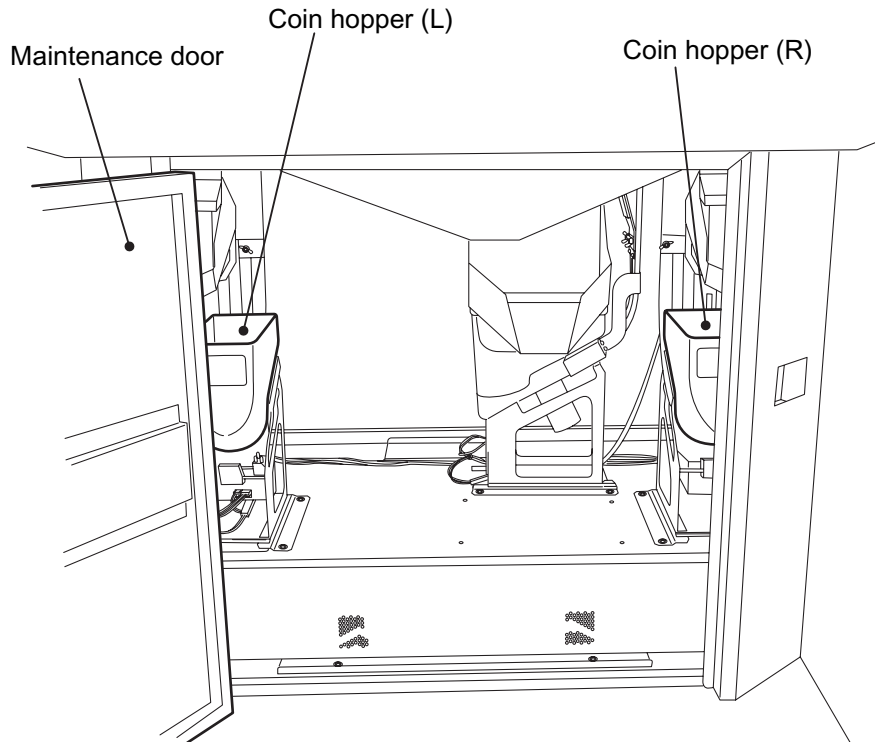

Note:

- These hoppers are used to supply coins to the playfield. Supply 200 to 300 coins to each of the hoppers (L) and (R). If too many coins are added, excessive load is applied to the motor which can shorten the working life of the coin hoppers.
- If a “1-13 or 1-23 Coin Hopper (L), (R) Empty” error occurs frequently, (except in the case of a jammed coin or empty hopper), increase the amount of coins within the above levels. This may reduce the frequency of error generation.
- Do not use dirty, damaged or severely scratched coins, as they may cause coin jamming.
- When the game is played for the first time after installation, a Hopper Empty error may occur. This error is generated because the game has not sensed a coin being fed to the playfield within a certain period of time. This is because of the time taken for the escalator to fully fill, and is not a malfunction. Cancel the error by referring to [6-3-4 Resetting errors page 96](#).

4-4-3 Loading the Playfield

1. Unlock and open the Playfield door. Evenly distribute coins on both the Pusher and Playfield.

**The recommended amount to load is: £80.00 in 10p coins - minimum £75.00
£15.00 in 2p coins - minimum £12.00**

2. After loading the Playfield, close and lock the Playfield door.

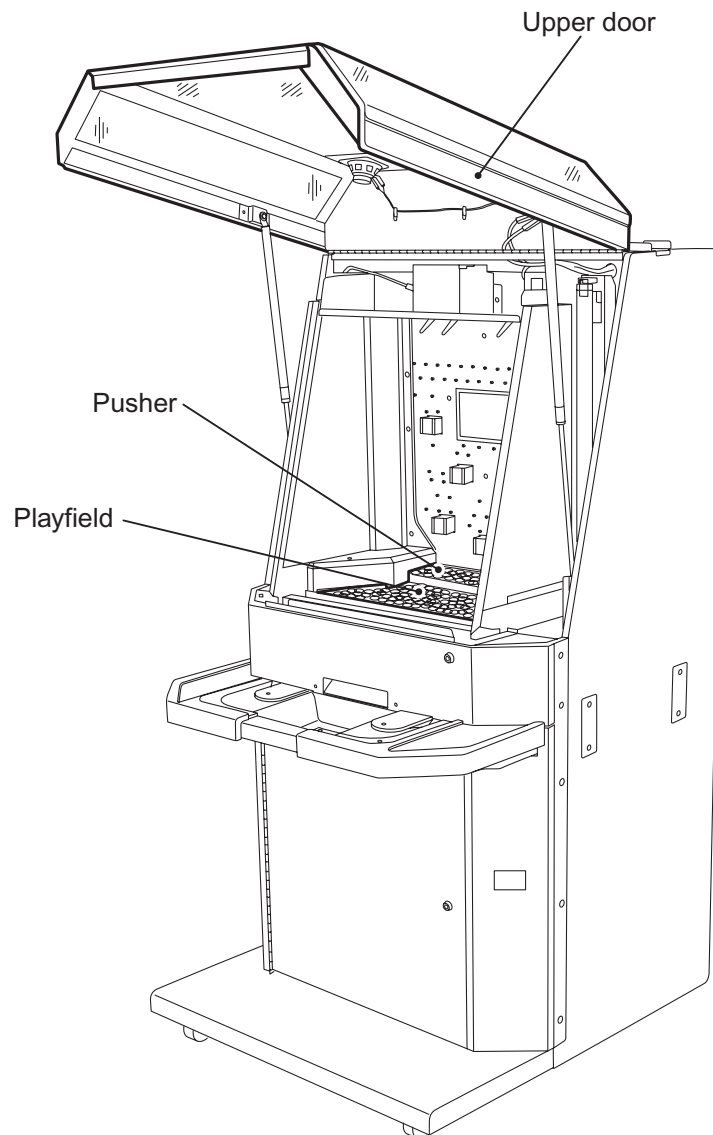

Note:

- This game is designed for coins only. Do not place prizes on the playfield as these can become stuck and cause a jam when falling to the payout tray.
- Do not use dirty, damaged or severely scratched coins, as they may cause coin jamming.

The payout rate may change suddenly in a new machine due to wearing-in caused by coins in the initial period of operation and the natural stacking of coins on the playfield. To maximise income, it is very important that following the installation of this game, the payout rate is checked regularly, and when necessary adjusted.

(see [5-7-7-3 page 65](#) 'Field Payout measurement mode' and [5-1 page 43](#) 'Adjustment of the Payout Rate')

Even after the game has been operating for some time, it is advisable to regularly check and adjust the payout rate as the following can all cause the payout rate to change.:

Coin Factors	Coin diameter, coin thickness, coin weight and coin surface patterns.
Environmental Factors	Temperature, humidity and the level of the machine.
Age Related Factors	Dirtiness of Coins, dirtiness of the Playfield and scratches to the Playfield.

It is recommended that the Payout is set to approx:

72% (Field Payout Rate: 40%) for 2p games
80% (Field Payout Rate: 44%) for 10p games

If the payout is set too low, the game may generate a higher profit for a given number of coins played, but may deter repeat players. With the payout set higher, the profit may be less but the game can attract more players generating a higher turnover. This is especially true in a site with regular customers.

5. ADJUSTMENTS



- Ⓒ **Adjustment or maintenance on this machine should be carried out by qualified personnel only.**
- Ⓓ **Einstellungen und Wartung des Gerätes dürfen nur von dafür qualifiziertem Fachpersonal vorgenommen werden.**
- Ⓔ **Justeringer eller vedligehold af denne maskine bør kun udføres af kvalificeret personale.**
- Ⓕ **Los ajustes y el mantenimiento de esta máquina deben ser realizados sólo por personal cualificado.**
- Ⓖ **L'installation, le service, le réglage, ou la maintenance doivent être effectués uniquement par les personnes qualifiées.**
- Ⓖ **Μετατροπές ή επιδιορθώσεις στα μηχανήματα πρέπει να γίνονται μόνο από εξουσιοδοτημένα άτομα.**
- Ⓘ **Regolazioni e manutenzione su questa macchina devono essere fatti solo da personale specializzato.**
- Ⓝ **Justering eller vedlikehold på denne maskinen skall bare utføres av kvalifiserte personell.**
- Ⓝ **Aanpassingen of onderhoud aan deze machine dient alleen uitgevoerd te worden door bekwaam personeel.**
- Ⓟ **Afinações ou manutenção nesta máquina, deverão ser efectuadas sómente por pessoal qualificado.**
- Ⓢ **Justeringar och underhåll på denna maskin skall endast utföras av kvalificerad personal.**
- Ⓢ **Tätä laitetta saa säätää tai huoltaa vain siihen ammattipätevyyden omaava henkilökunta.**

5-1 Adjustment of the Payout Rate

5-1-1 Adjustment of the Front Edge

By adjusting the vertical position of the front edge of the playfield, the field payout rate - (the ratio of the number of coins dispensed to the playfield to the sum of coins inserted and coins discharged from the coin hopper (C)) - can be varied.

When the front edge is raised, the playfield rate decreases and when the front edge is lowered the rate increases.

1. Unlock and open the Playfield door.
2. Remove 1 off socket head screw (M4x6) and remove the left side cover.
3. Loosen 2 off socket head screws (M4x6) and remove the top.

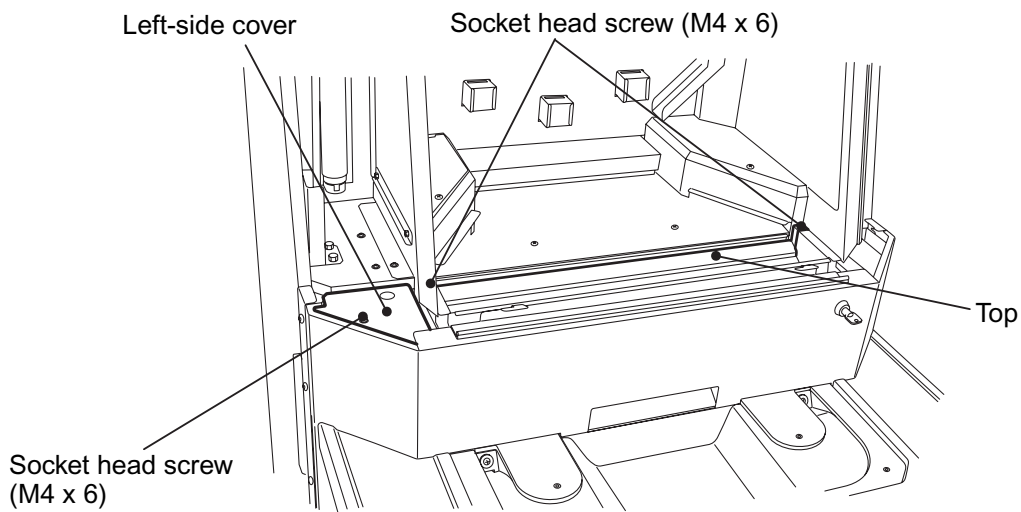

4. Loosen 3 off socket head screw (M4x14)

Note: Do not remove these screws, as internal parts will become detached and fall out of place.

Ensure that the screws are re-tightened after adjustment

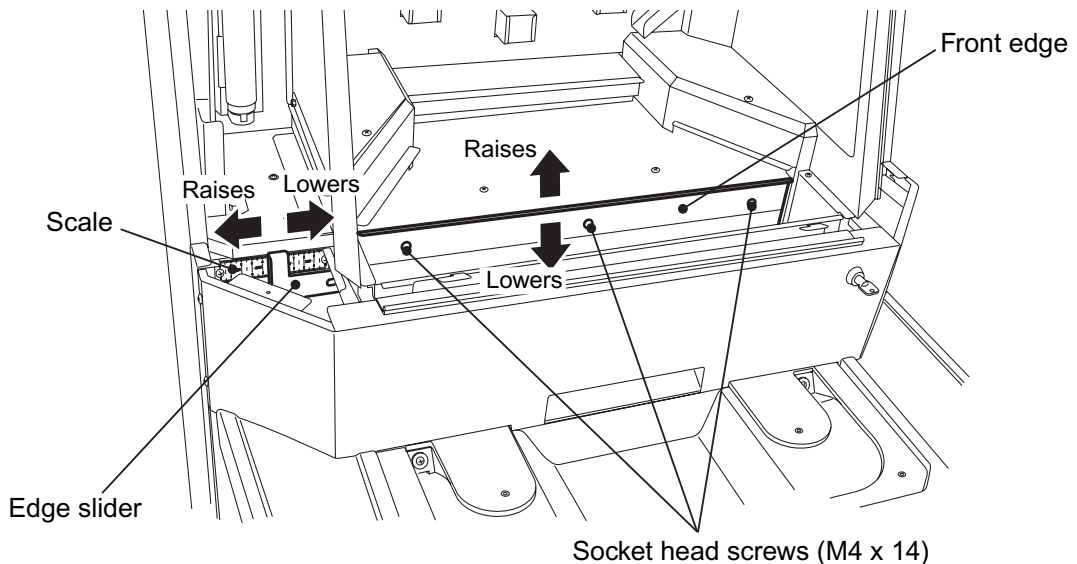

5. Move the edge slider fully to the right, (to remove any slack), and then move it to the left to the required position to adjust the height of the front edge.

The edge slider MUST first be moved fully to the right to ensure accurate adjustment.

Moving the edge slider to the left by 1mm raises the front edge by 0.1mm and moving the edge slider to the right 1mm lowers the front edge by 0.1mm.

6. Retighten the 3off socket head screws (M4x14)

5-1-2 Measurement of the Field Payout Rate

- An approximate Field Payout Rate can be made by using the “Field Payout Rate measurement Mode” in the test mode. (see 5-7-3-3 page 65)
- It is recommended that the scale value, measured data, and date of measurement are retained for future comparisons.

Note:

The edge slide scale value is only a guide. The actual field payout rate should be calculated as above.

5-1-3 Basic Payout Rate

The Payout Rate is the ratio of the ‘number of coins paid out’ to the ‘total number of coins inserted’.

FIELD P/O	36%	38%	40%	42%	44%	46%	48%	50%	52%	54%
PAYOUT	64.8%	68.4%	72.0%	75.6%	79.2%	82.8%	86.4%	90.0%	93.6%	97.2%

The following table provides the data of theoretical payout rates based on the field payout rate.

It is recommended that the Payout is set to approx 90% (Field Payout Rate: 50%)

If the payout is set too low, the game may generate a higher profit for a given number of coins played, but may deter repeat players.

With the payout set higher, the profit may be less but the game can attract more players generating a higher turnover. This is especially true in a site with regular customers.

5-1-4 Adjustment of the Side Edges

- There is normally no need to adjust the side edges In normal operation.
 - The side edges are factory set to the furthest end.
1. Unlock and open the Playfield Door.
 2. Remove 1 off pozihead screw (M4x6) from each Stage Plate and remove the Stage Plates L & R.

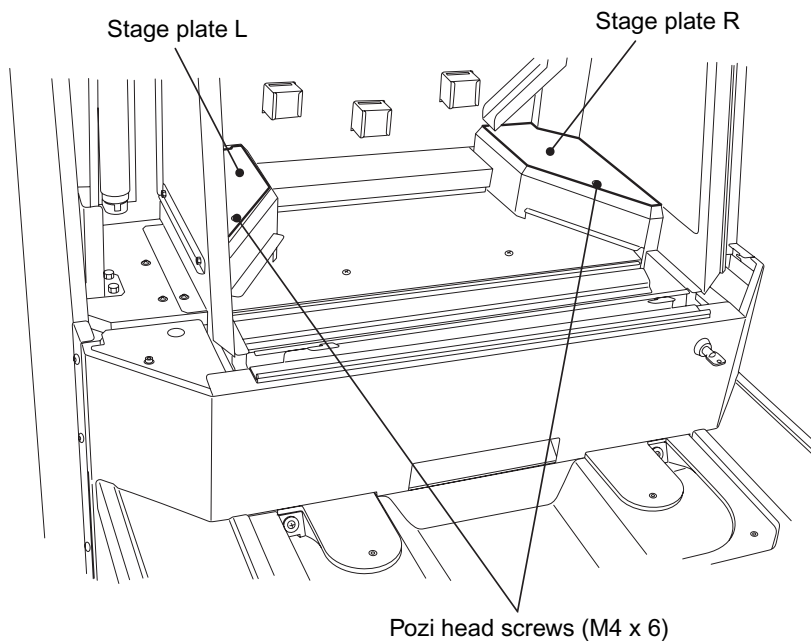

3. Loosen the 2 off cap screws (M4x20) and move the Side Edges (L), (R) forwards or backwards for adjustment.

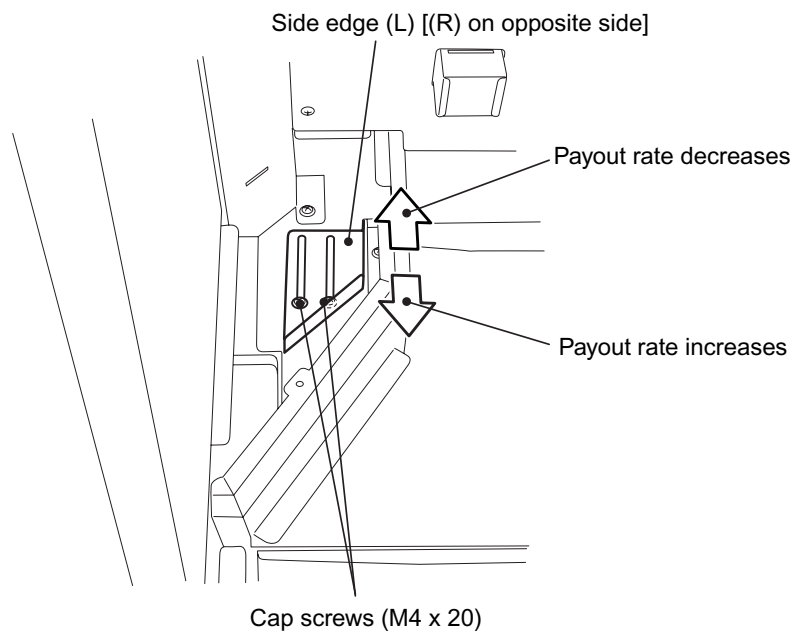

4. Re-assemble in reverse order.

5-3 Resetting the Tilt

The tilt device can be reset in two ways: manual reset (default setting) performed by a member of staff, or automatic reset.

It is also possible to disable the tilt function.

The method of changing the setting is described in [5-7-2 page 58](#).

To adjust the tilt sensitivity refer to [4-3 page 37](#).

- **Manual Reset**

1. Unlock and open the Playfield Door.
2. Turn the Test switch, located in the upper right corner of the cabinet, On and then Off to reset the alarm.
3. Close and lock the Playfield Door.

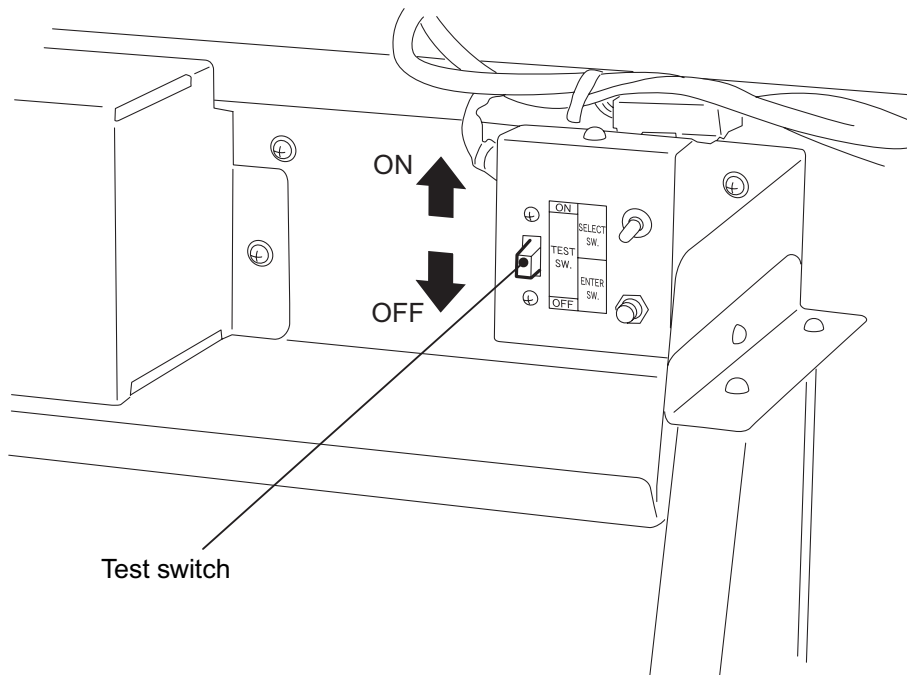

- **Automatic Reset**

When the tilt is set to automatic reset, the alarm will reset 10 seconds after it has been activated.

5-4 Adjusting for Coin Acceptance

5-4-1 Adjustment of the Coin Acceptors

The following details describe the procedure for removing the Coin Acceptor (R). Follow the same procedure for the removal of Coin Selector (L)

1. Remove 4 off tork screws (M5x12).

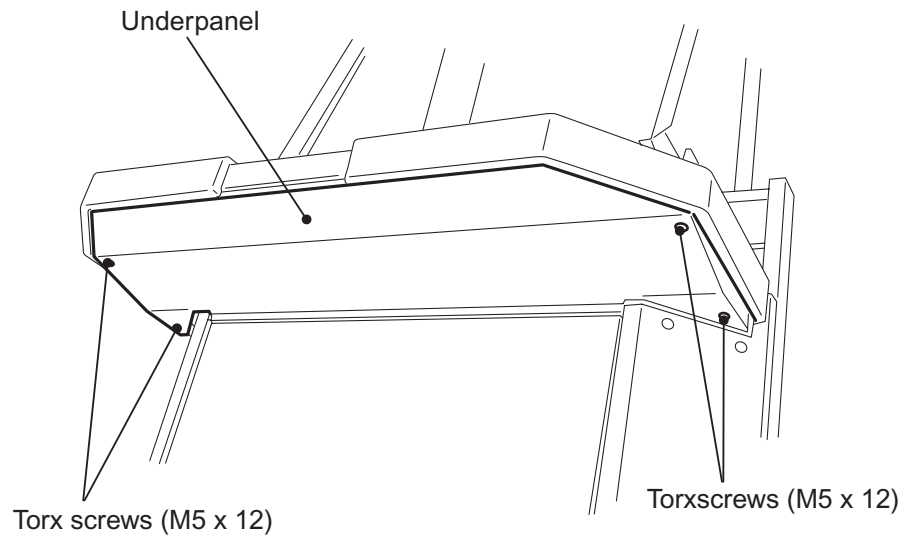

2. Unlock and open the Coin door, and remove the underpanel by sliding it towards the back.

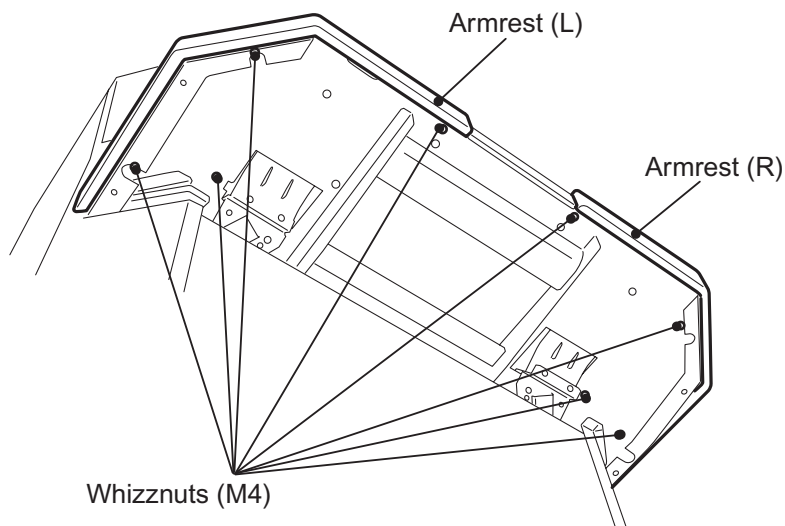

3. Remove 8 off whizznuts (M4) and remove the Armrests (L) and (R).

4. Remove 2 off cap screws (M4x6), disconnect the one connector and one Earth terminal, and remove the Coin Selector.

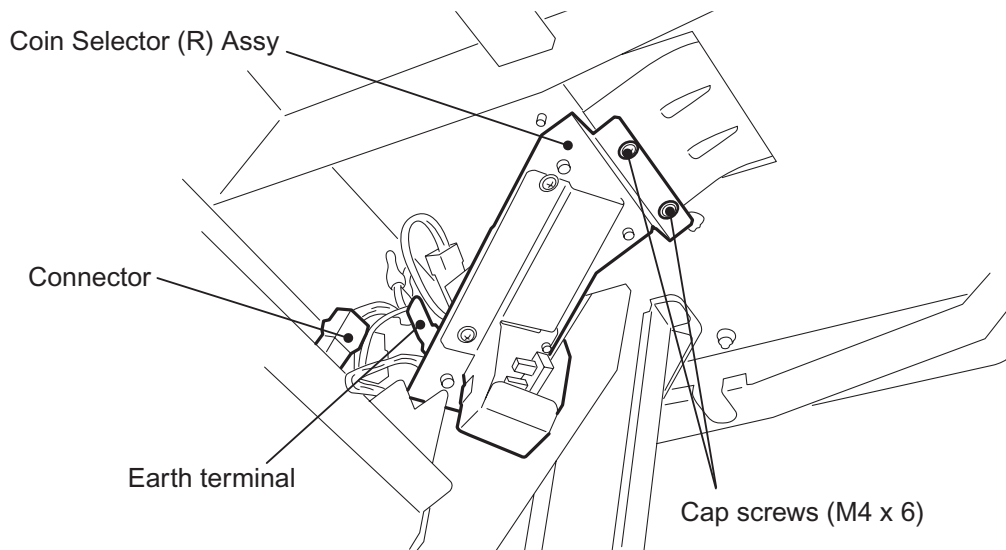

5. Remove 1 off cap screw (M4x10), loosen 1 off cap screw (M4x10), and remove the Coin Out (R) or (L)

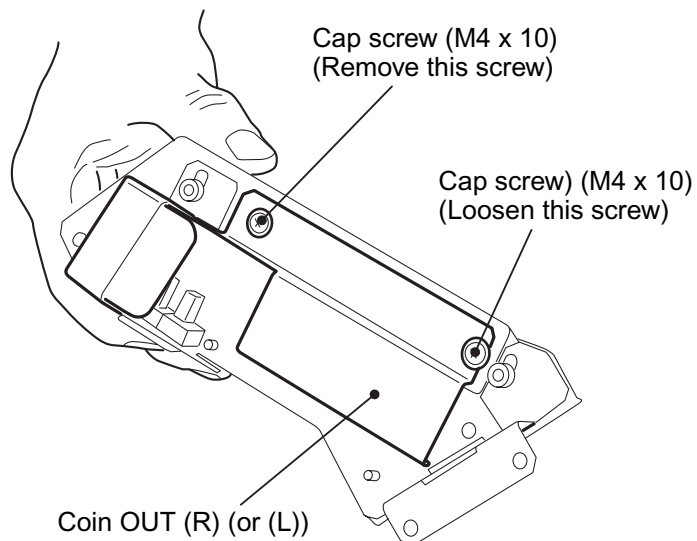

6. Loosen 2off flange sockets (M4x6), and adjust the position of the Adjuster Plate (R) or (L).
 Make the adjustment so that the width indicated in the diagram below is the diameter of the coin minus 0.5 to 0.6mm.
Note: Measure the width at both ends of the acceptor to ensure that the Adjuster Plate is parallel.

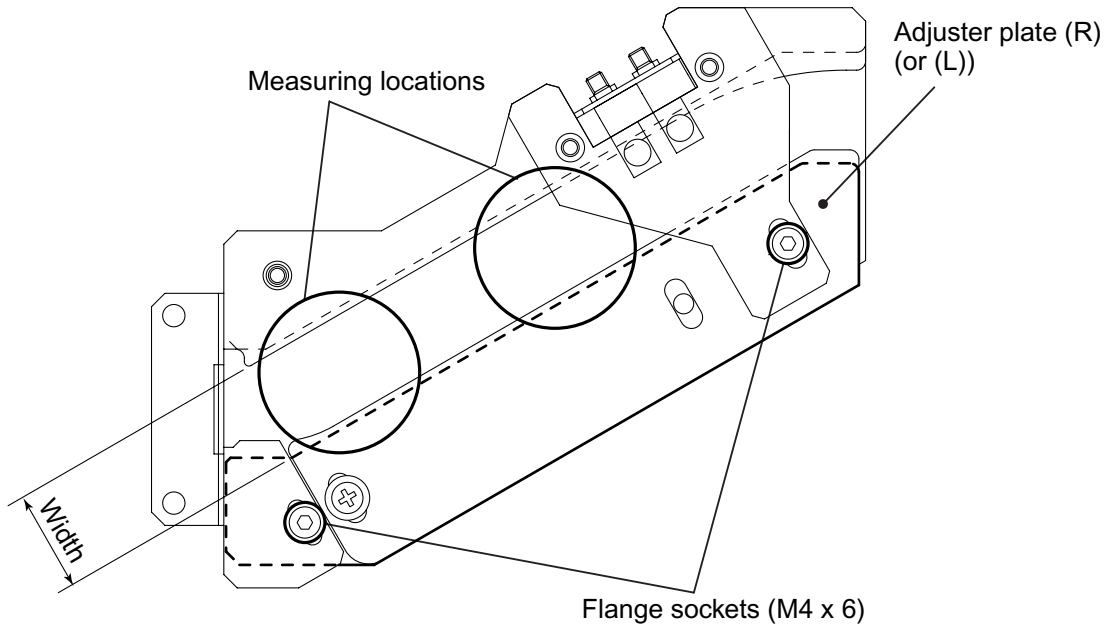

7. To confirm the adjustment, arrange coins inside the Coin Acceptor Assy, and make sure that, with the Adjuster Plate at the bottom, the coins overlap the Acceptor Base by 0.5 to 0.6mm.

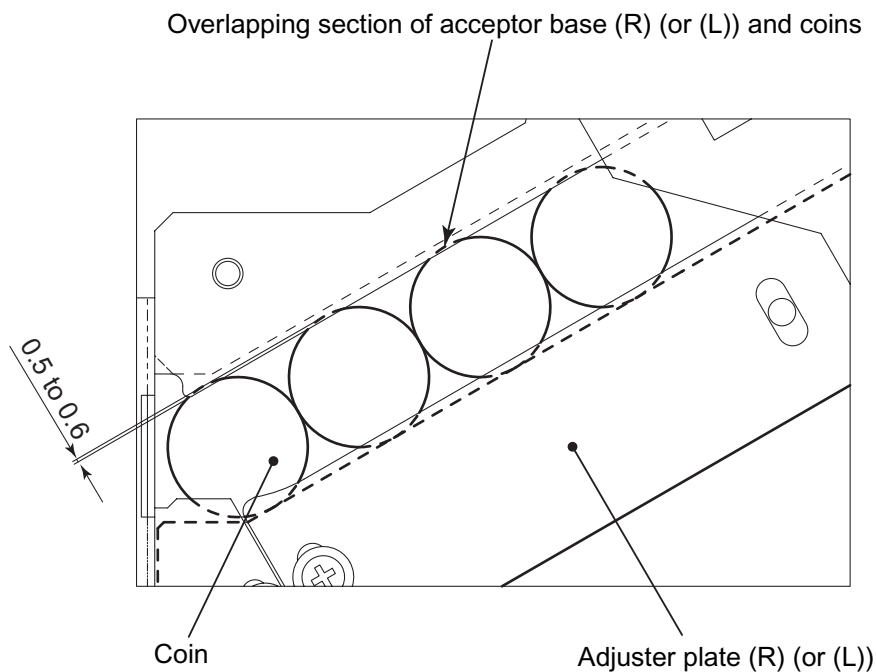

8. After adjustment, tighten the 2off flange sockets (M4x6), and reassemble in the machine in the reverse order of removal.

5-5 Adjusting the Coin Entry

1. Remove the Coin Acceptor Assy. ([see 5-4 page 47](#)).
2. Loosen 2 off cap screws (M4x6) and 1 off button head screw (M4x6), and slide the Coin Adjuster (L) to adjust the width and height of the coin entry slot.

The dimensions should be set as follows:

Width: Diameter of coin + 0.2 to 0.4mm

Height: Thickness of coin + 0.4 to 0.6mm

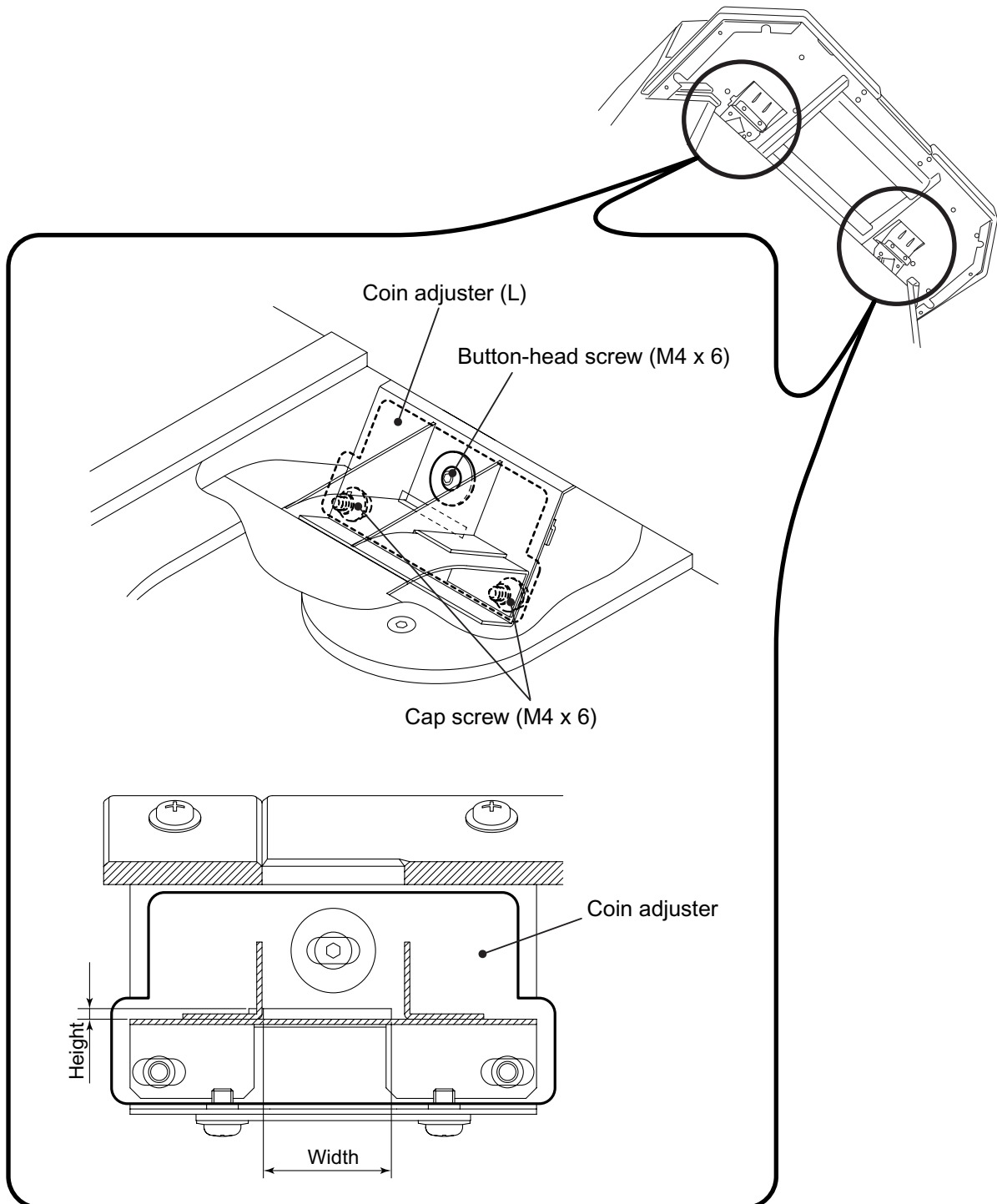

The following describes the adjustment procedure.

1. Cut four strips of photocopy paper to a width slightly narrower than the diameter of the coin. Stack the four pieces of paper, and insert them together with a coin into the coin slot.
2. Move the Coin Adjuster (L) toward the lower left direction so that it is just in contact with the coin. (In the case of the Coin Adjuster (R), move it toward the lower right).
3. Move the Coin Adjuster (L) to the right so that there is a gap as wide as one sheet of paper on either side of the coin. (In the case of the Coin Adjuster (R), move it to the left).

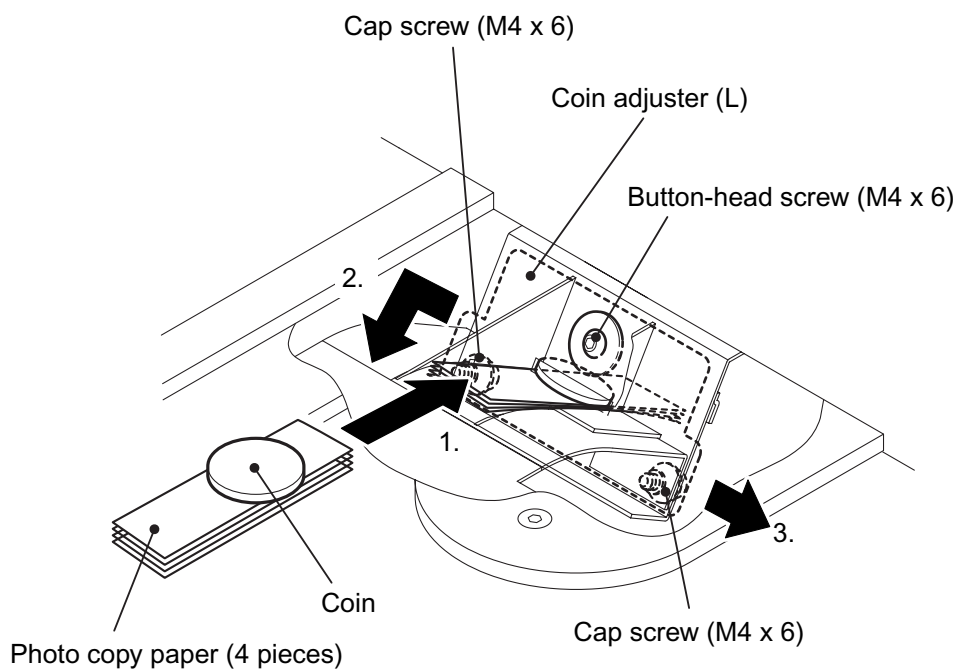

- After adjustment, ensure that the 2 off cap screws (M4x6) and 1 off button head screw (M4x6) are fully tightened.
- Insert at least 10 coins to make sure that they slide smoothly.

5-6 Adjustment Switches

The Adjustment switches are located at the top of the game behind the Playfield door.

(a) Test Switch

Slide the test switch ON to enter test mode.

Test mode allows testing and the changing of game settings.

[\(Refer to section 5-7 "Test Mode" page 53\)](#)

(b) Select Switch

Push this switch up or down to select an item within the test menus.

(c) Enter Switch

This switch is used to enter a selected test and to change settings within a test.

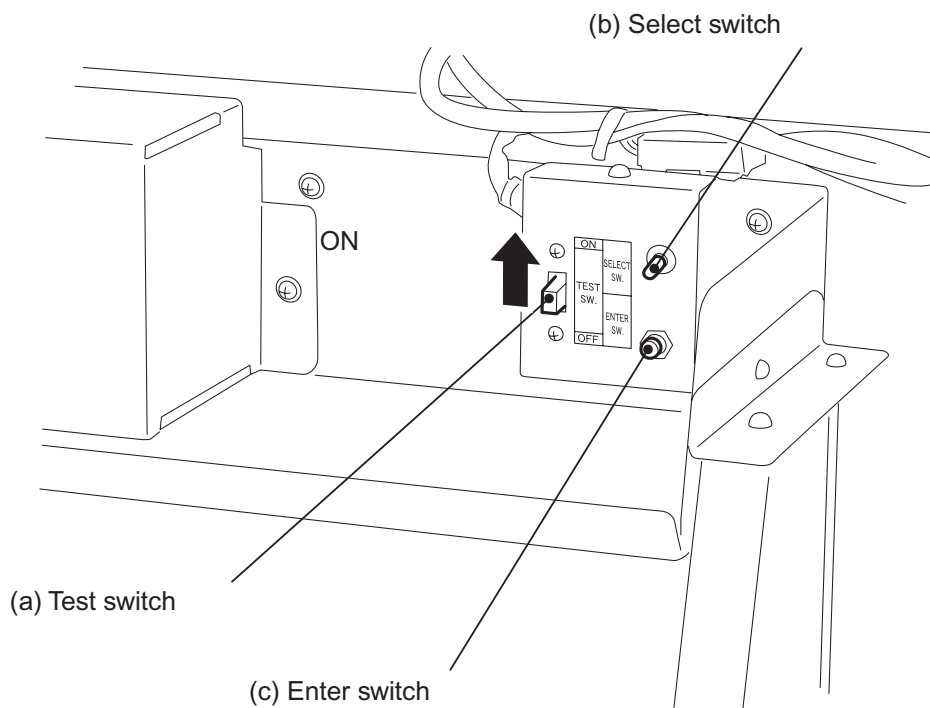

5-7 Test Mode

Coins cannot be inserted when the game is in the Test Mode except when SENSOR TEST screen is displayed.

1. Turn the Test Switch ON. The following screen is displayed.
2. Operate the Select Switch up or down to select an item on the screen. The selected item is indicated in red.
3. Press the Enter Switch to enter the selected item.
4. After adjustment, select "EXIT" and press the Enter Switch. The display returns to the MENU screen.
5. After all adjustments have been completed, switch the Test Switch OFF. The display returns to the game screen.

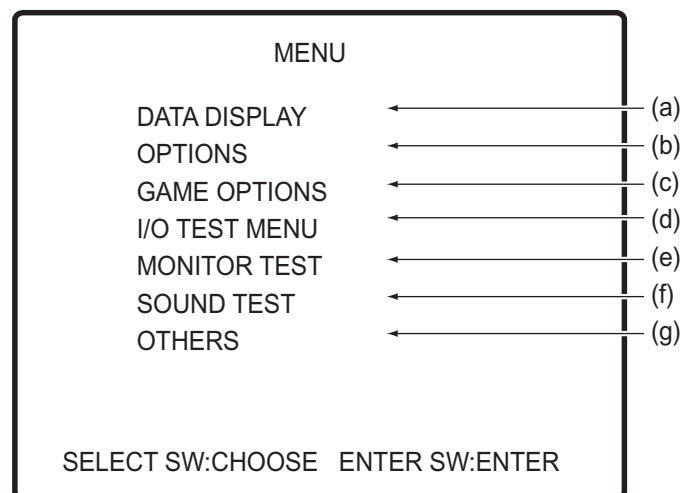

- (a) For display and initialization of data. (5-7-1 page 54)
- (b) For setting the Payout Rate, Tilt, etc. (5-7-2 page 58)
- (c) There are no Option settings for this game.
- (d) For Input and Output tests. (5-7-3 page 59)
- (e) For adjustment of the Monitor. (5-7-4 page 68)
- (f) For adjustment of the Sound levels. (5-7-5 page 69)
- (g) For initialization of Backup Memeory. (5-7-6 page 70)

5-7-1 Displaying and Initializing the Data

5-7-1-1 Income Data

1. Select "DATA DISPLAY" on the menu screen and press the Enter switch. The following screen is displayed.
 2. The DATA DISPLAY consists of four pages. Operate the Select switch Up or Down to select an item. The selected item is displayed in red.
 3. Press the Enter switch to confirm selection.
 4. After adjustments are completed, select "EXIT" and press the Enter switch. The display returns to the Menu screen.
- If "MGEXIO ERROR" is indicated in the upper left corner of the DATA DISPLAY screen, correct data may not be displayed.
(see [Error Code 3-2 page 94](#))

DATA DISPLAY		1/4
INCOME DATA		
TOTAL COINS IN	0 (UNCLEAR) (a)
TOTAL HOPPER(C) OUT	0 (UNCLEAR) (b)
COINS IN	0 (c)
HOPPER(C) OUT	0 (d)
INTERMEDIATE P/O	0.0% (e)
NEXT (f)
DATA CLEAR (g)
EXIT		
SELECT SW:CHOOSE	ENTER SW:ENTER	

INCOME DATA screen (first page)

- (a) Total Cumulative number of coins inserted in left and right entries.
- (b) Cumulative number of coins discharged from coin hopper "C"
 - Data (a) and (b) are not erased when "Data Clear" is initiated.
- (c) Total number of coins inserted on right and left.
- (d) Number of coins discharged from coin hopper "C".
- (e) Medium payout rate calculated based on data (c) and (d)
 - Data (c),(d) and (e) are those collected after "Data Clear" was last initiated.
- (f) Displays the next page (page 2)
- (g) Clears data (deletes all data except data (a) and (b). When the Enter switch is pressed, the display prompts for input "YES" or "NO")
NO (Data not cleared)
YES (Data reset)

5-7-1-2 Security Data

1. Select "NEXT" form Data Display screen page 1 and press the Enter button. The following screen is displayed. (This screen shows game play

DATA DISPLAY		2/4
SECURITY DATA		
POWER ON TIME	00000:00' 00 (a)
TOTAL PLAY TIME	00000:00' 00 (b)
AVE. PLAY TIME	00000:00' 00 (c)
PLAY/ON RATIO	00.0% (d)
PLAY COUNT	000000 (e)
NEXT	(f)
DATA CLEAR	(g)
EXIT		
SELECT SW:CHOOSE	ENTER SW:ENTER	

data.) **SECURITY DATA screen (second page)**

- (a) Power ON time. (Indicates cumulative power ON time in hours, minutes and seconds)
 - (b) Total play time. (Indicates cumulative play time in hours, minutes and seconds)
 - (c) Average play time. (Indicates average game play time in hours, minutes and seconds)
 - (d) Operating rate. (Indicates percentage of play time in power ON time)
 - (e) Total number of plays. (Indicates total number of game plays)
 - (f) Displays the next page (third page)
 - (g) Clears data. When the Enter switch is pressed, the display prompts for input "YES" or "NO"
NO (Data not cleared)
YES (Data reset)
- Indicated times are approximate. The manufacturer does not guarantee the accuracy of the displayed data.

5-7-1-3 Machine Data (hardware data)

1. Select "NEXT" from Security Data Display screen page 2 and press the Enter button. The following screen is displayed. (This screen shows the number of mechanism operations and checker activation counts.)

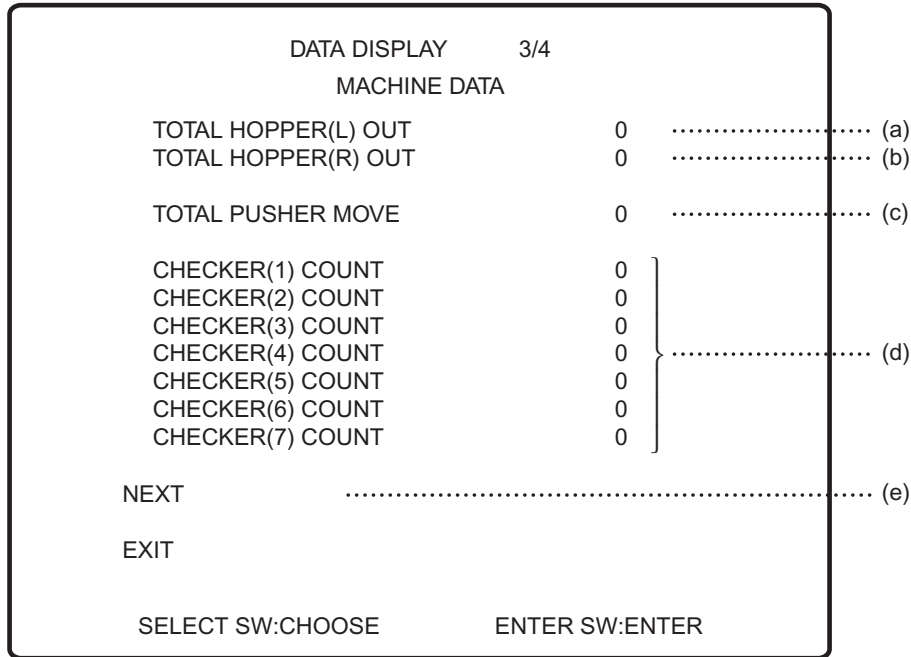

MACHINE DATA screen (third page)

- (a) Cumulative number of coins discharged from hopper (L).
- (b) Cumulative number of coins discharged from hopper (R).
- (c) Cumulative number of pusher operations.
- (d) Cumulative number of checker activation counts.
- (e) Displays the next page. (fourth page)

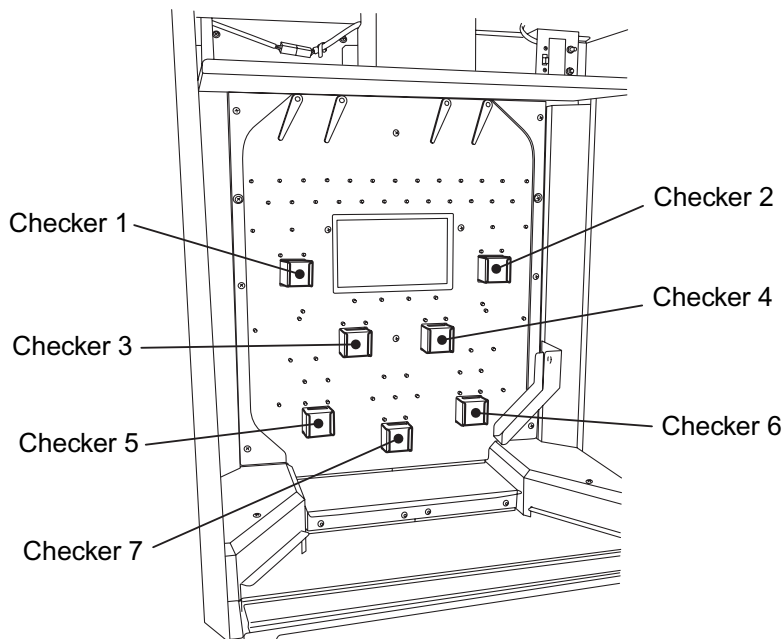

5-7-1-4 Error History

1. Select "NEXT" from Machine Data Display screen page 3 and press the Enter button. The following screen is displayed. (This screen shows the last ten errors. (error codes and messages)

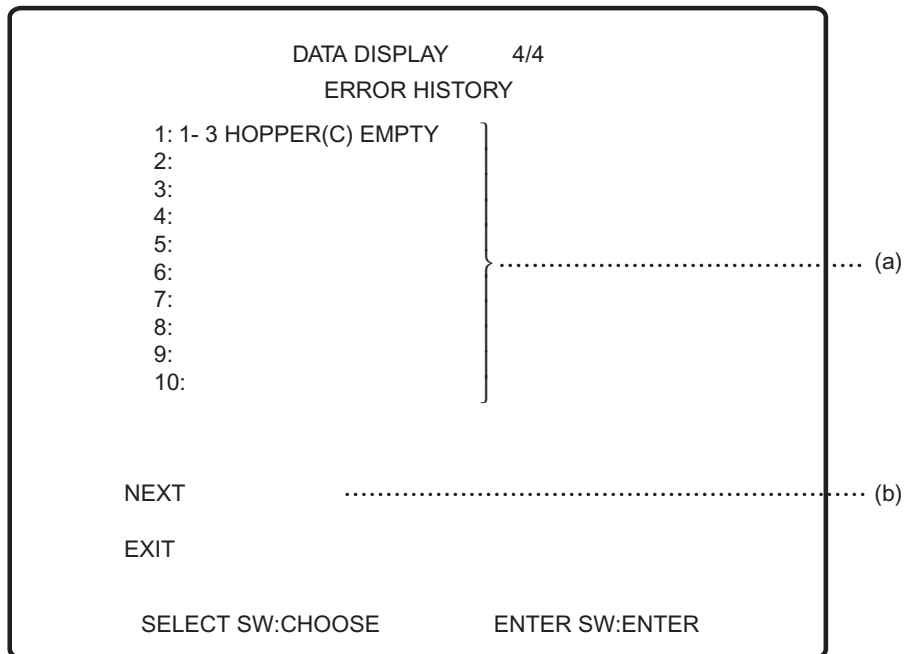

ERROR HISTORY screen (fourth page)

- (a) Error codes, error messages. (most recent shown at the top) ([see 6-3-3 page 93](#) for list of error indications)
- (b) Displays the next page. (returns to first page of data display)

5-7-2 Options

1. Select "OPTIONS" on the menu screen and press the Enter switch. The following screen is displayed.
2. Operate the Select switch Up or Down to select an item. The selected item is displayed in red.
3. Press the Enter switch to confirm selection.
4. After the item has been selected, use the Select switch to change the setting.
5. After the setting has been changed, press the Enter switch. The screen returns to the item selection mode.
6. Select "EXIT" and press the Enter switch to return to the Menu screen.

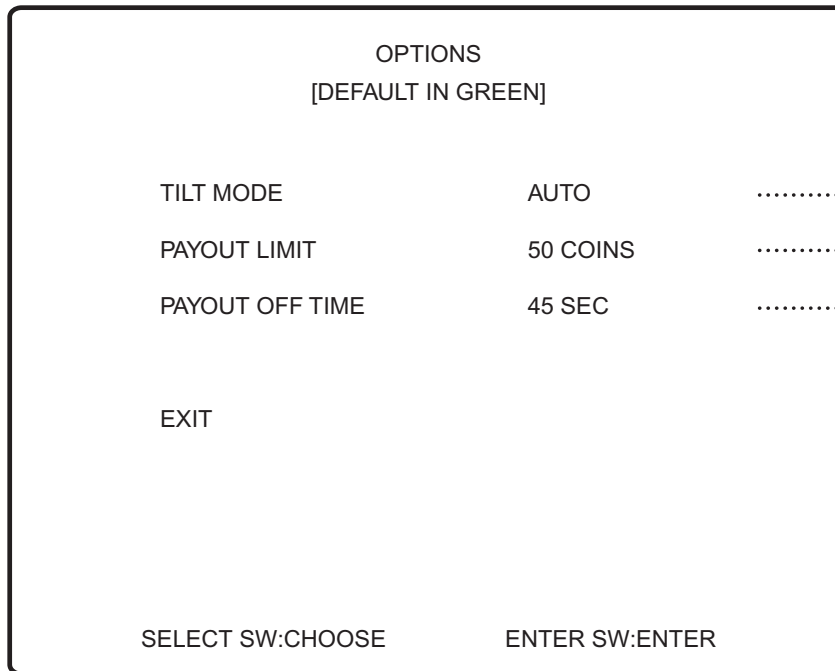

Item	Description	Factory Setting
(a) Tilt Setting	AUTO (Automatic reset after 10seconds) MANUAL (error status remains until manually reset) OFF (no tilt action)	AUTO
(b) Maximum coin dispensing limit setting	50 COINS 250 COINS 999 COINS	250 COINS 2p Game 50 COINS 10p Game
(c) Payout divider operation setting	30 SEC 45 SEC 60 SEC	45 SEC

5-7-3 Input/Output Test

1. Select "I/O TEST MENU" on the menu screen and press the Enter switch. The following screen is displayed.

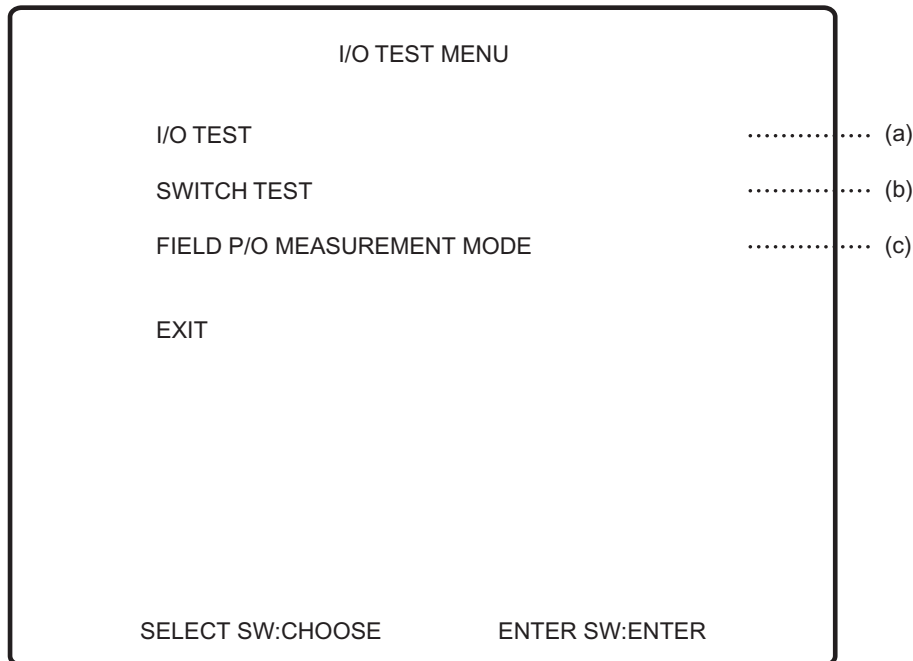

2. Operate the Select switch Up or Down to select an item. The selected item is displayed in red.
 3. Press the Enter switch to confirm selection.
 4. After the test for the selected item has been completed, select "EXIT" and press the Enter switch to return to the I/O Menu screen.
 5. Select "EXIT" and press the Enter switch to return to the Menu screen.
- If "MGEXIO ERROR" is indicated in the upper left corner of the DATA DISPLAY screen, correct data may not be displayed. (see [Error Code 5-11 page 95](#))
- (a) Input/output test. (see [5-7-3-1 page 60](#))
 - (b) Input/output test for adjustment switches. (see [5-7-3-2 page 64](#))
 - (c) Measurement of Field Payout rate. (see [5-7-3-3 page 65](#))

5-7-3-1 I/O Test

This screen is used for input and output tests.

- Operations are not accepted while "WAIT!" is displayed in the upper left corner of the screen.

Sensor Test (Test page 1 of 4)

This checks the Tilt switch and coin sensors for proper operation.

- Coins can be inserted when this screen is displayed.
1. Select "I/O TEST" on the menu screen and press the Enter switch. The following screen is displayed.

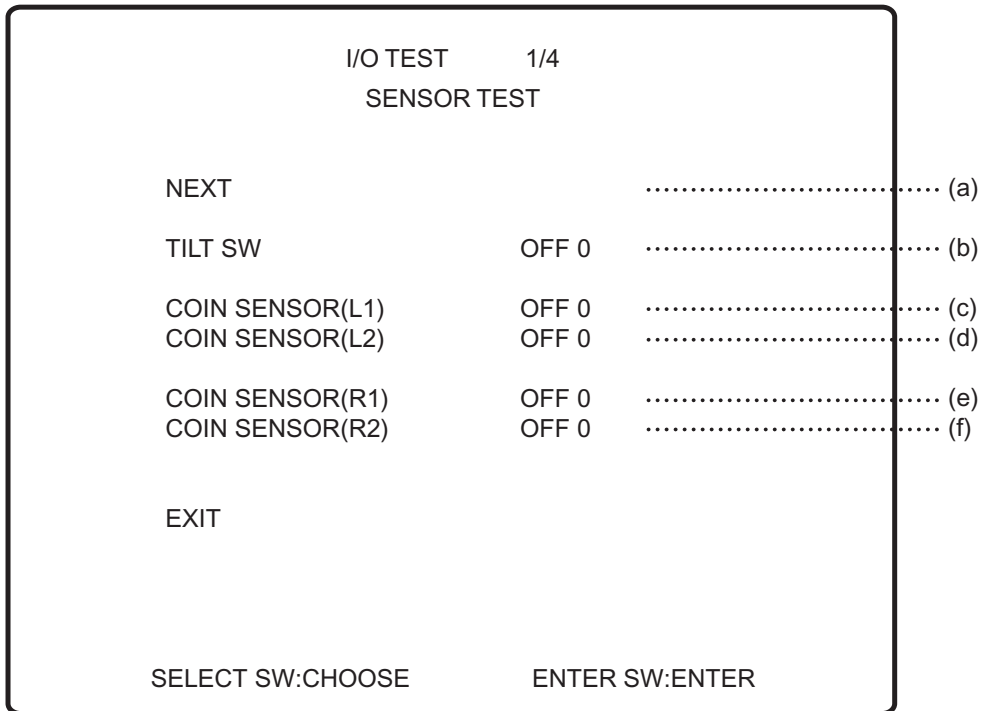

2. Operate the Select switch Up or Down to select an item. The selected item is displayed in red.
 3. Press the Enter switch to confirm selection.
 4. After the test for the selected item has been completed, select "EXIT" and press the Enter switch to return to the I/O Menu screen.
- (a) Displays the next page (second page)
(b) Displays the Tilt switch ON/OFF status
(c) Displays the Coin Sensor (L1) ON/OFF status
(d) Displays the Coin Sensor (L2) ON/OFF status
(e) Displays the Coin Sensor (R1) ON/OFF status
(f) Displays the Coin Sensor (R2) ON/OFF status

Motor Test (Test page 2 of 4)

This screen is used to test the Pusher Motor and Coin Hoppers.

I/O TEST		2/4
MOTOR TEST		
NEXT	 (a)
PUSHER MOTOR	OFF SENSOR OFF 0 (b)
HOPPER(C)	OFF SENSOR OFF 0 (c)
HOPPER(L)	OFF SENSOR OFF 0 (d)
HOPPER(R)	OFF SENSOR OFF 0 (e)
	CHECKER SENSOR(1) OFF 0	} (f)
	CHECKER SENSOR(2) OFF 0	
	CHECKER SENSOR(3) OFF 0	
	CHECKER SENSOR(4) OFF 0	
	CHECKER SENSOR(5) OFF 0	
	CHECKER SENSOR(6) OFF 0	
	CHECKER SENSOR(7) OFF 0	
EXIT		
SELECT SW:CHOOSE		ENTER SW:ENTER

- 1 Operate the Select switch Up or Down to select an item. The selected item is displayed in red.
 2. The selected test is executed while the Enter switch is held pressed
 3. When the Enter switch is released, the test stops.
 4. After the test for the selected item has been completed, select "EXIT" and press the Enter switch to return to the I/O Menu screen.
- (a) Displays the next page (third page).
- (b) Operates the Pusher Motor. Displays the pusher sensor ON/OFF status.
- (c) Operates the Coin Hopper (C). Displays the coin hopper (C) sensor ON/OFF status.
- (d) Operates the Coin Hopper (L). Displays the coin hopper (L) sensor ON/OFF status.
- (e) Operates the Coin Hopper (R). Displays the coin hopper (R) sensor ON/OFF status.
- (f) Displays the ON/OFF status of the Checker Sensors (1) thru (7)
- Items (c), (d) and (e) can be used to empty coins from the coin hoppers.
 - The Pusher Motor operates while the Coin Hopper (L), (R) is activated.
 - **When the game stops operation due to a coin hopper error, do not operate the coin hopper in the coin hopper test as this could cause damage to the coin hopper.**

Solenoid Test (Test page 3 of 4)

This screen is used to test the Solenoids.

I/O TEST		3/4
SOLENOID TEST		
NEXT	 (a)
PAYOUT SOLENOID	OFF (b)
LOCKOUT SOL (L)	OFF (c)
LOCKOUT SOL (R)	OFF (d)
DIVIDER SOL (L)	OFF	SENSOR OFF (e)
DIVIDER SOL (R)	OFF	SENSOR OFF (f)
EXIT		
SELECT SW:CHOOSE		ENTER SW:ENTER

- 1 Operate the Select switch Up or Down to select an item. The selected item is displayed in red.
2. The selected test is executed while the Enter switch is held pressed
3. When the Enter switch is released, the test stops.
4. After the test for the selected item has been completed, select "EXIT" and press the Enter switch to return to the I/O Menu screen.

- (a) Displays the next page (fourth page).
- (b) Operates the Payout Solenoid.
- (c) Operates the Lockout Solenoid (L)
- (d) Operates the Lockout Solenoid (R)
- (e) Operates the Divider Solenoid (L). Displays the Divider Sensor (L) ON/OFF status.
- (f) Operates the Divider Solenoid (R). Displays the Divider Sensor (R) ON/OFF status.

LED / Lamp Test (Test page 4 of 4)

This screen is used to test the LED and Lamps.

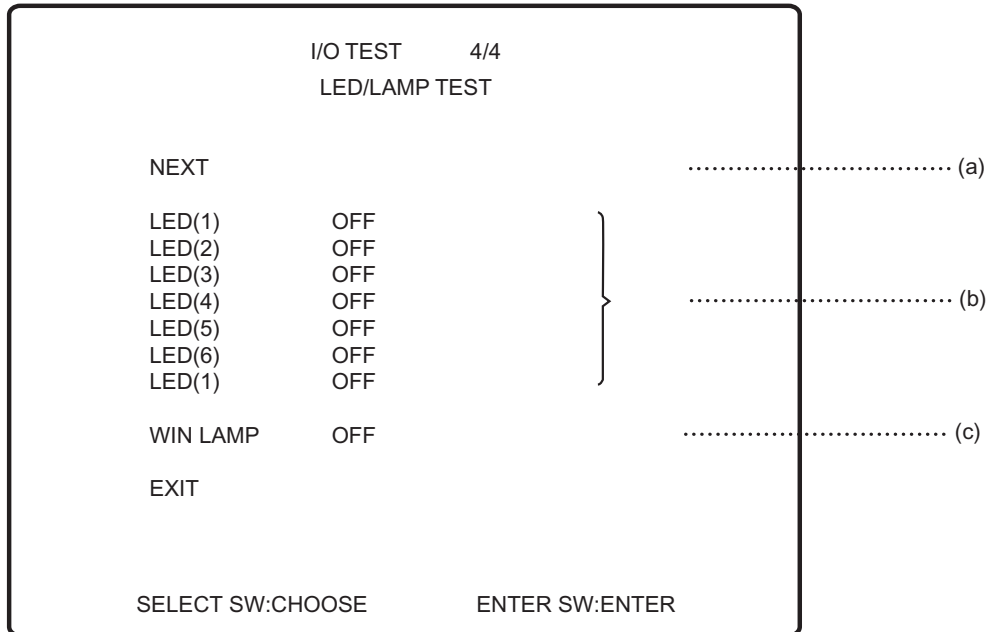

- 1 Operate the Select switch Up or Down to select an item. The selected item is displayed in red.
2. The selected test is executed while the Enter switch is held pressed
3. When the Enter switch is released, the test stops.
4. After the test for the selected item has been completed, select "EXIT" and press the Enter switch to return to the I/O Menu screen.

- (a) No Action.
- (b) Turns on LEDs (1) thru (7).
- (c) Turns on the Win Lamp.

5-7-3-2 Switch Test

This screen is used to test the Switches.

1. Select Switch Test from the I/O TEST Menu, the following screen is displayed.

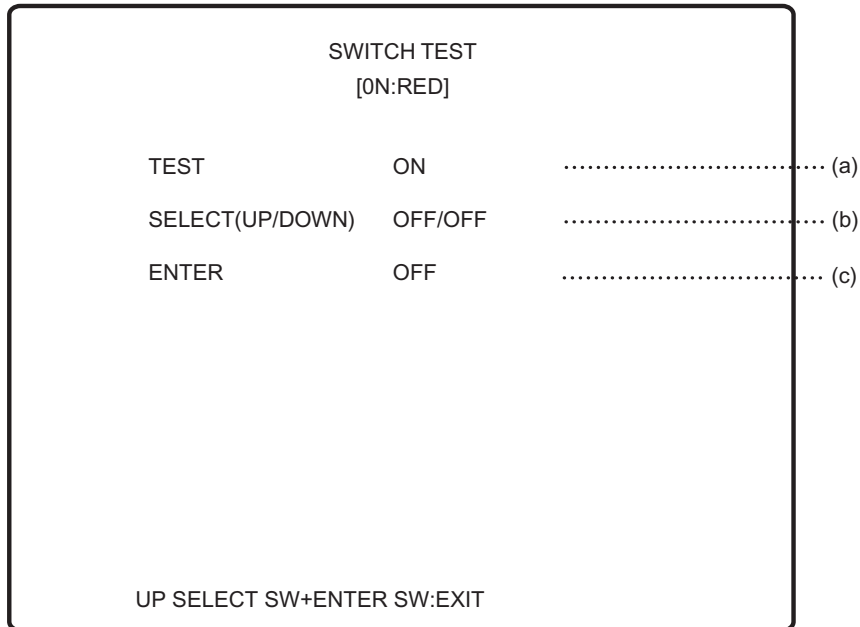

2. The display changes from OFF to ON when the corresponding switch is operated.
3. To return to the I/O TEST Menu screen, hold the Select switch up and press the Enter switch.

- (a) Displays "ON"
- (b) The indication changes to "ON" when the Select switch is moved in the direction indicated.
- (c) Displays "ON" when the Enter switch is pressed.

* When the Test switch is turned off, the test mode ends, and the display returns to the game screen.

5-7-3-3 Field P/O Measurement Mode (field payout rate measurement mode)

The percentage of coins dispensed to players (dispensed to the coin tray) to all coins inserted and coins discharged from the coin hopper (C) in this game is called the “field payout rate”.

This mode is used to measure the field payout rate in a simplified manner.

1. Select FIELD P/O MEASUREMENT MODE from the I/O Test Menu screen. The following screen is displayed.

After the measurement is completed, press the Enter switch. The display will return to the I/O TEST MENU.

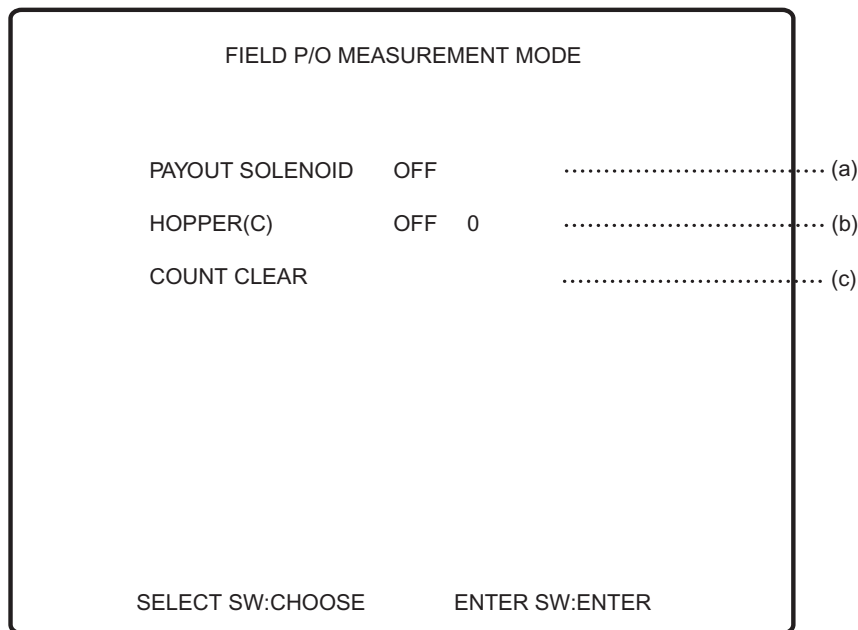

- (a) Turns the payout solenoid ON/OFF
- (b) Turns the Coin Hopper (C) ON/OFF. Displays the number of discharged coins.
- (c) Clears the count of the coins discharged by Coin Hopper (C). When the Enter switch is pressed, the display prompts for the input “YES” or “NO”.
NO (Count not cleared)
YES (Count cleared)

It is recommended to measure the payout rate by using this mode following installation or any changes to the playfield, or levelling of the machine.

The payout rate may change suddenly in a new machine due to wearing-in, caused by coins, in the initial period of operation and the natural stacking of coins on the playfield. To maximise income, it is very important that following the installation of this game, the payout rate is checked regularly, and when necessary adjusted.

Even after the game has been operating for some time, it is advisable to regularly check and adjust the payout rate as the following can all cause the payout rate to change.

Coin Factors	Coin diameter, coin thickness, coin weight and coin surface patterns.
Environmental Factors	Temperature, humidity and the level of the machine.
Age Related Factors	Dirtiness of Coins, dirtiness of the Playfield and scratches to the Playfield.

Procedures for Field Payout Rate Measurement

Procedure 1 (preparing the measurement conditions)

1. Remove all coins from the playfield.
2. Add sufficient coins to the Coin Hopper (C).
3. Make sure that the Payout Solenoid is turned off.
4. Clear the count for Coin Hopper (C).
5. Turn the Coin Hopper (C) on. The Coin Hopper (C) stops automatically after it has discharged 2000 coins (approx 35 minutes)
6. Ensure that the coins are distributed evenly on the playfield so that the measurement can be performed properly.

Procedure 2 (preparing for measurement)

1. Add sufficient coins to the Coin Hopper (C).
2. Turn the Payout Solenoid ON so coins that fall from the front edge are sent to the coin tray.
3. Turn the Coin Hopper (C) on. The Coin Hopper (C) stops automatically after it has discharged 2000 coins (approx 35 minutes)
**If the Coin Hopper (C) becomes empty before discharging 2000 coins, it stops automatically to protect the hopper motor from damage. Add coins and turn the hopper on again.*
4. Count the coins that have fallen onto the tray.
5. The Payout Rate can be calculated using the following equation:
Number of coins fallen to the coin tray \div (Number of coins discharged from coin hopper (C) (2000 coins) x 100 = field payout rate (%)

Note:

- Use the calculated field payout rate as a guideline only. The calculated rate may differ from the actual value.
- Repeated measurements can increase accuracy of data. However, to ensure that the measurement is made under the same conditions, always start from step 1.
- The actual field payout rate varies according to the players playing style. Record the calculated measurements and compare them with the actual payout rate for enhanced accuracy.
- The actual field payout rate can be calculated by the following equation:
$$\text{COINS OUT (measured value)} \div (\text{COINS IN} + \text{HOPPER (C) OUT}) = \text{Measured Field Payout Rate (\%)}$$

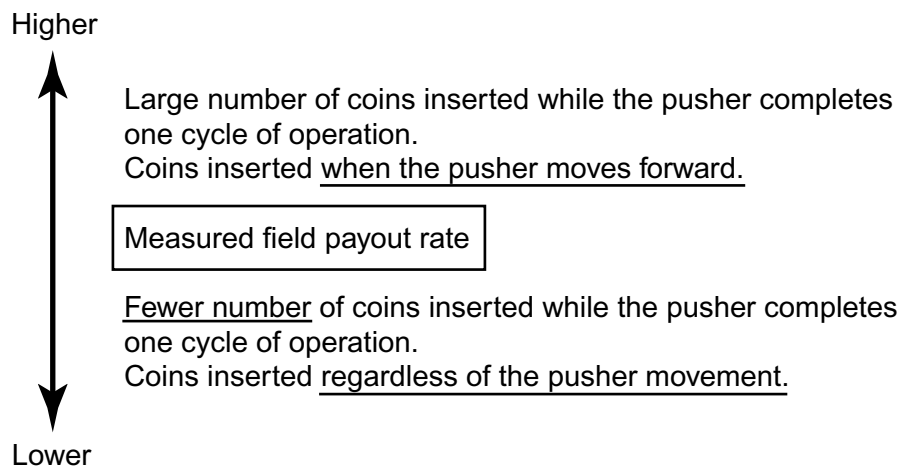

Change in field payout rate due to players style.

5-7-4 Monitor Test

1. Select "MONITOR TEST" from the Test Menu Screen, then press the enter button. The following screen is displayed.

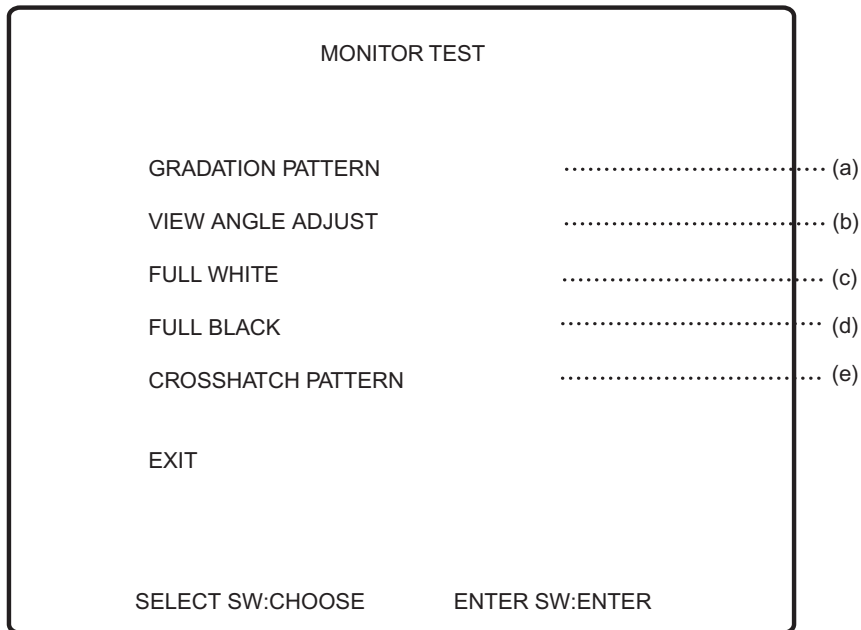

2. Operate the Select switch up or down to select an item. The selected item is displayed in red.
 3. Press the Enter switch to display the selected pattern.
 4. To exit from the selected pattern screen, press the Enter switch.
 5. To return to the MENU screen, select "EXIT" and press the Enter switch.
- (a) Displays the Gradation Pattern.
(b) Displays the Adjustment screen.
(c) The screen changes to white.
(d) The screen changes to black.
(e) Displays a Crosshatch Pattern.

5-7-5 Sound Test

1. Select "SOUND TEST" from the Test Menu Screen, then press the enter button. The following screen is displayed.

SOUND TEST			
[DEFAULT IN GREEN]			
VOLUME	ALL SP	(0~1270	64 (a)
	attract	(0~127)	64 (b)
	error	(0~127)	64 (c)
REQUEST SONG NO.		000 (d)
MESSAGE LR CHECK		 (e)
		 (f)
EXIT			
SELECT SW:CHOOSE		ENTER SW:ENTER	

2. Operate the Select switch up or down to select an item. The selected item is displayed in red.
3. When item (a), (b), (c) or (d) is selected, and the Enter switch is pressed, the value of the selected item changes to red. Operate the Select switch up or down to change the value.
4. For item (e), each time the Enter switch is pressed, the digit changes. Operate the Select switch up or down to set the value for the selected digit. After the last digit value has been set, press the Enter switch to play the music or sound associated with that number.
"000" is for a stereo test. When "000" is set and the Select switch pressed, sound is produced first from the Left speaker, then the Right speaker and then Both speakers. During this test "LEFT", "RIGHT" or "CENTRE" is displayed at the location (f) according to which speaker is operating.
5. When the selected adjustment has been made, press the Enter switch to return to the item selection mode.
6. To return to the MENU screen, select "EXIT" and press the Enter switch.

Item	Description	Factory Setting (indicated in red)
(a) Game sound volume level	00 (minimum) to 127 (maximum)	64
(b) Attract mode volume level	00 (minimum) to 127 (maximum)	64
(c) Alarm sound volume level	00 (minimum) to 127 (maximum)	64
(d) Music	Selection of music/sound effect	000

5-7-6 Others

This screen is used to initialize the backup memory and others.

1. Select "OTHERS" from the Test Menu Screen, then press the enter button. The following screen is displayed.

OTHERS			
[DEFAULT IN GREEN]			
ROM VER.	X MMM DD YYYY	12:34:56 (a)
S/N	FFFFFF-FFFFFF	 (b)
PAUSE	OFF	 (c)
BACKUP MEMORY INITIALIZE		 (d)
EXIT			
SELECT SW:CHOOSE		ENTER SW:ENTER	

2. Operate the Select switch up or down to select an item. The selected item is displayed in red.
 3. Press the Enter switch to confirm the selection.
 4. After the selected setting has been changed operate the Select switch to return to the item selection mode.
 5. To return to the MENU screen, select "EXIT" and press the Enter switch.
- (a) Displays the Software Version.
- (b) Displays the Game PC Board Serial Number.
- (c) Used to set the Pause Display Function.
When "ON" is selected and the Enter switch operated, the pause function becomes effective and pauses the display. Operating the Enter switch again, releases the pause function and the display returns to normal operation. By operating the Select switch up during the pause mode, the display can be advanced frame by frame. This function is set to OFF (indicated in green) at the factory.
- (d) Initializes the Backup Memory.
When "YES" is selected and the Enter switch is operated, all data including the income data, security data, hardware data, error history and setting data are cleared, and the settings returned to factory default.

6. MAINTENANCE

- GB** Adjustment or maintenance on this machine should be carried out by qualified personnel only.
Ensure that the POWER to the machine is turned OFF before commencing any maintenance work. (Trouble shooting, service or repairs etc.)
- D** Einstellungen und Wartung des Gerätes dürfen nur von dafür qualifiziertem Fachpersonal vorgenommen werden.
Vor Beginn aller Wartungsarbeiten (Fehlersuche, Reparaturen etc.) muß der Netzstecker gezogen werden.
- DK** Justeringer eller vedligehold af denne maskine bør kun udføres af kvalificeret personale.
Sørg for, at strømmen til maskinen er slukket før der foretages nogen form for arbejde (fejlfinding, reparation etc.)
- E** Los ajustes y el mantenimiento de esta máquina deben ser realizados sólo por personal cualificado.
Asegúrese de que la máquina está desconectada antes de comenzar cualquier trabajo de mantenimiento (reparaciones, resolución de problemas, etc.)
- F** L'installation, le service, le réglage, ou la maintenance doivent être effectués uniquement par les personnes qualifiées.
S'assurer que l'interrupteur soit sur OFF avant de commencer tout travail de maintenance (localisation d'une panne, réparations, etc.)
- GR** Μετατροπές ή επιδιορθώσεις στα μηχανήματα πρέπει να γίνονται μόνο από εξουσιοδοτημένα άτομα.
Να είναι σίγουρα κλειστό το ρεύμα πριν οποιαδήποτε δουλειά στο μηχάνημα.
- I** Regolazioni e manutenzione su questa macchina devono essere fatti solo da personale specializzato.
Assicurarsi che la macchina sia SPENTA prima di incominciare qualsiasi lavoro di manutenzione (guasti, riparazioni etc.)
- N** Justering eller vedlikehold på denne maskinen skall bare utføres av kvalifiserte personell.
Forsikre deg om at strømmen er slått av før du påbegynner noe som helst vedlikeholdsarbeid (feilsøking, reparasjon osv.)

- (NL)** Aanpassingen of onderhoud aan deze machine dient alleen uitgevoerd te worden door bekwaam personeel.
Zorg ervoor dat de machine UITgeschakeld is voordat er enig onderhoudswerk wordt verricht (troubleshooting, reparaties etc.)
- (P)** Afições ou manutenção nesta máquina, deverão ser efectuadas sómente por pessoal qualificado.
Certifique-se que a máquina se encontra desligada sempre que iniciar qualquer tipo de trabalho de manutenção. (identificação de avarias, reparação etc.)
- (S)** Justeringar och underhåll på denna maskin skall endast utföras av kvalificerad personal.
Försäkra dig om att strömmen är avstängd innan underhållsarbete påbörjas (felsökning, reparationer etc.)
- (SF)** Tätä laitetta saa säätää tai huoltaa vain siihen ammattipätevyyden omaava henkilökunta.
Varmista, että laite on kytketty POIS PÄÄLTÄ ennen työn aloittamista.

6-1 Regular Inspection

Check the following items regularly.

1. Inspection of Level Adjusters

- Make sure that the machine is stable and secure.

2. Inspecting the Power Cable

- Make sure that the Power cable is connected securely.
- Check that there is no damage to the Power Cable. If there is any damage replace the Power Cable before operating the game.

3. Inspecting Screws and Bolts

- Check that the following screws and bolts for tightness. If they are loose, tighten them firmly.
- Mounting screws and bolts for the Upper Door and Gas-Cylinder Springs.
- Mounting nut for the Playfield Base.

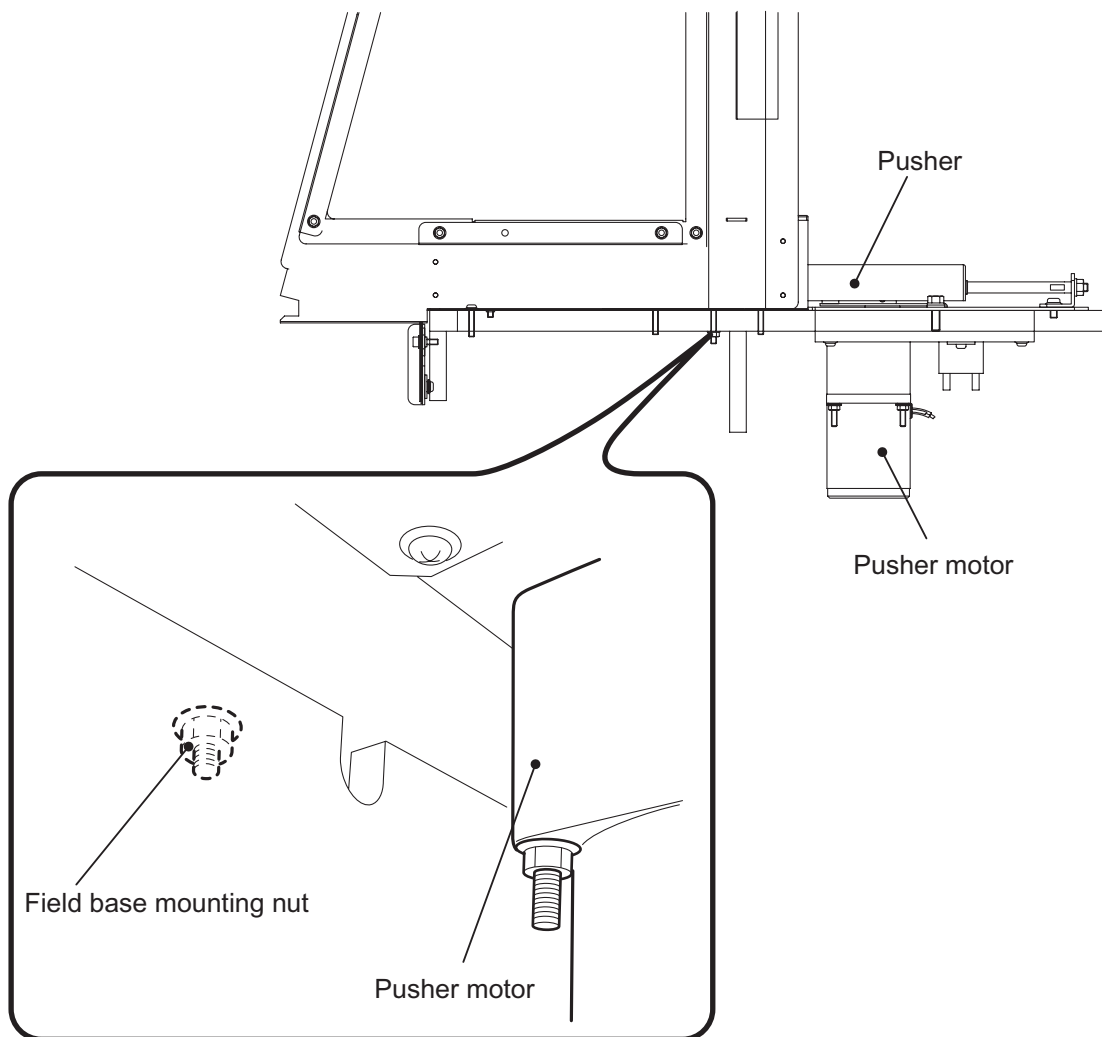

6-2 Cleaning

6-2-1 Cleaning the Coin Trays

Do not use organic solvents such as thinners, petroleum spirits etc. as these can damage the machine.

1. Wipe the Coin Tray and Coin Entry Slots with a dry soft cloth. If they are excessively dirty, dampen a soft cloth with a neutral detergent and wipe clean.

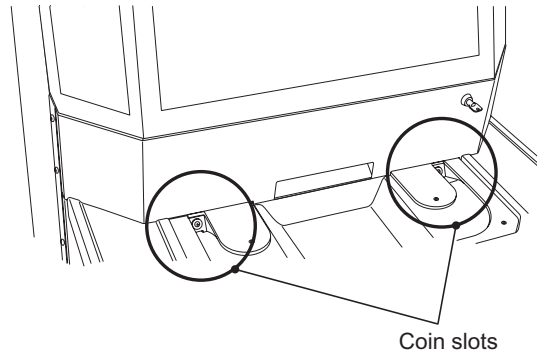

6-2-2 Cleaning the Bonus Exit

Do not use organic solvents such as thinners, petroleum spirits etc. as these can damage the machine.

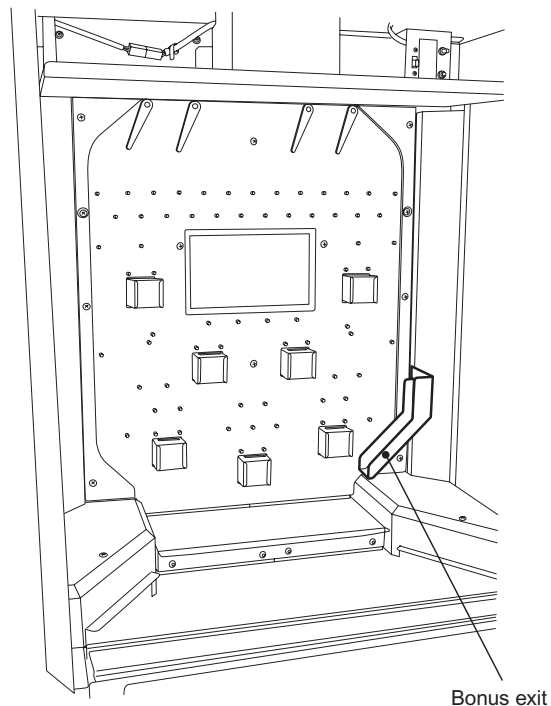

1. Unlock and open the Playfield Door.
2. Wipe the Bonus Exit with a dry soft cloth. If they are excessively dirty, dampen a soft cloth with a neutral detergent and wipe clean.
3. Close and re-lock the Playfield Door.

6-2-3 Cleaning the Payout Assy

Do not use organic solvents such as thinners, petroleum spirits etc. as these can damage the machine.

1. Unlock and open the Playfield Door.
2. Remove the 4 off button head screws (M6x20), 2 off button head screws (M4x6) and 2 off flat washers (M4), then remove the front cover.

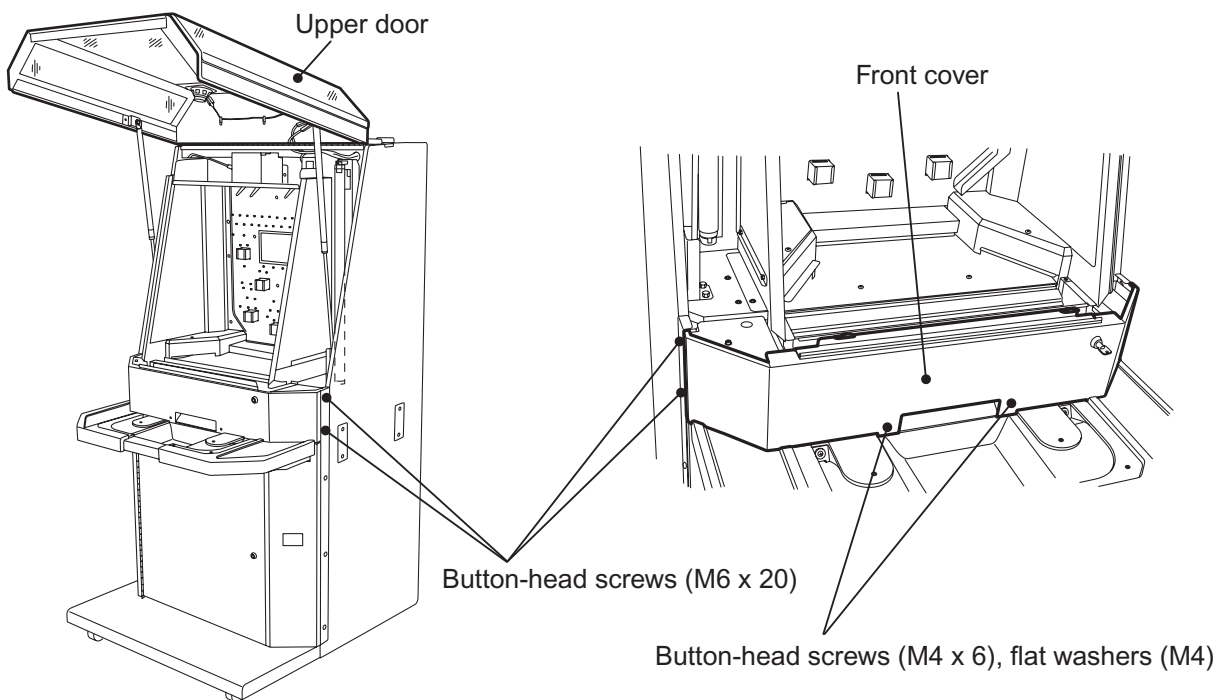

3. Remove 2 off pozi head screws (M4x6), and detach the Front (L) Guard.

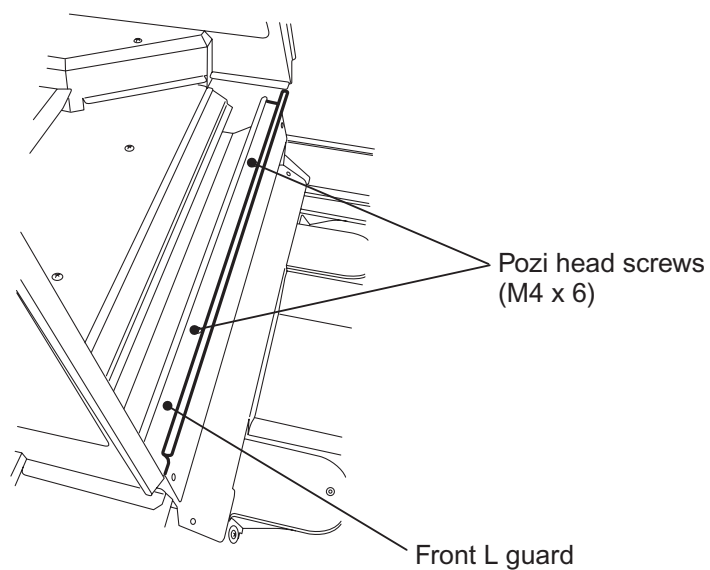

4. Remove 4 off cap screws (M4x6) , and remove the Front Piece.

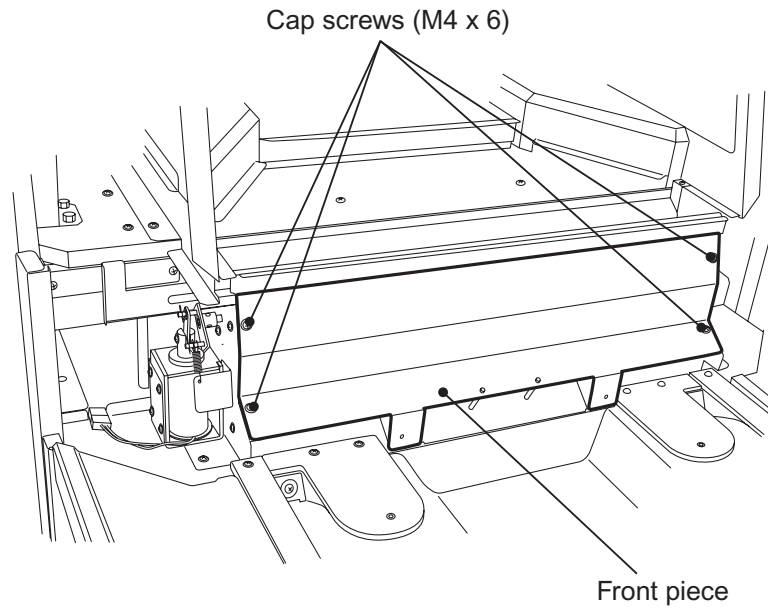

5. Wipe the Payout Assy with a dry soft cloth. If they are excessively dirty, dampen a soft cloth with a neutral detergent and wipe clean.

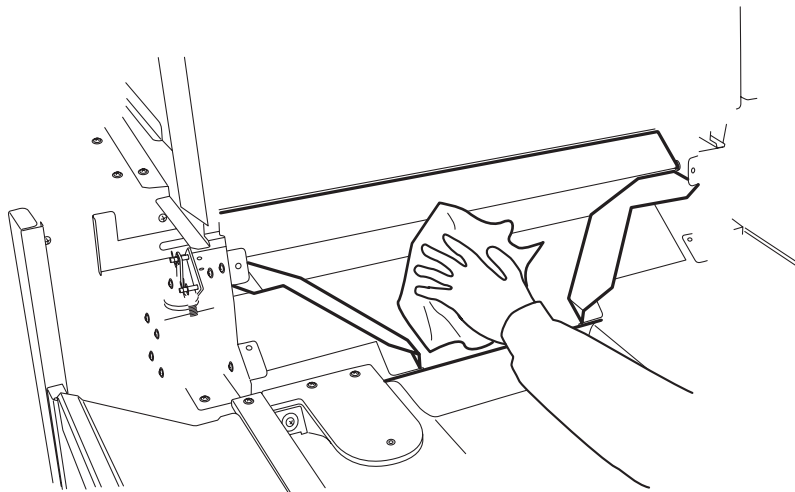

6. Re-assemble in reverse order.

6-2-4 Cleaning the Coin Selector

Do not use organic solvents such as thinners, petroleum spirits etc. as these can damage the machine.

1. Remove the Coin Selector (R) Assy (See 5-4 page 47).
2. Remove 2 off cap screw (M4x10) from the Selector Base (R) Side, and remove the Coin Out (R).

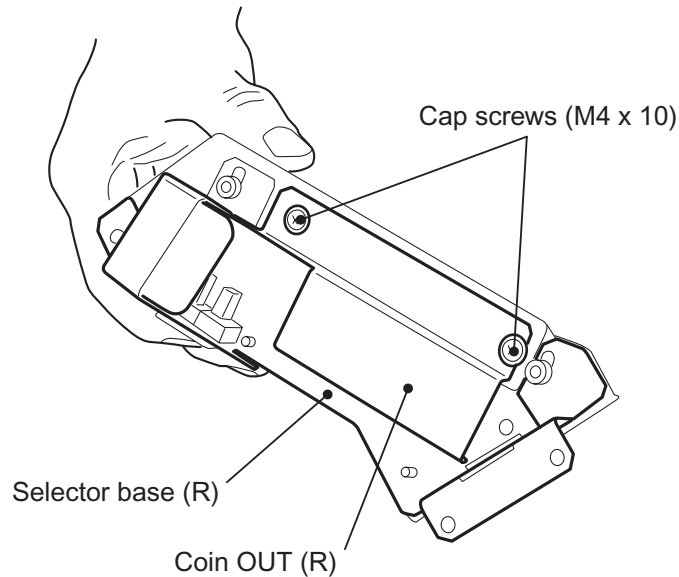

3. Remove 3 off cap screws (M4x10), and remove the Upper Plate (R)

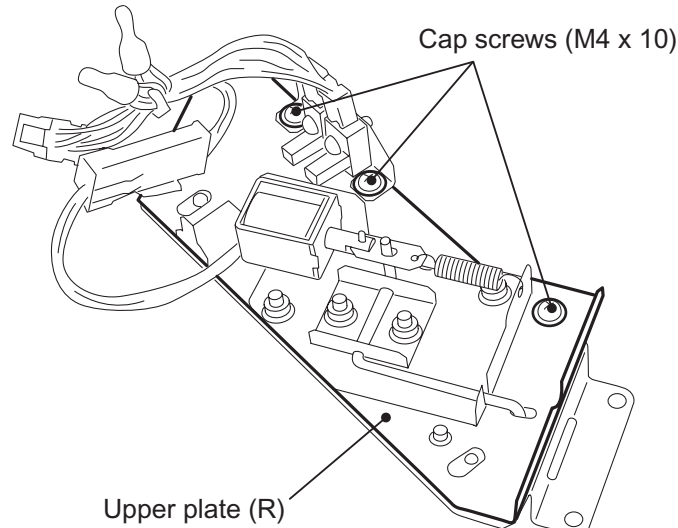

4. Wipe the coin passages in the Selector Base (R) and Upper Plate (R) with a dry soft cloth. If they are excessively dirty, dampen a soft cloth with a neutral detergent and wipe clean.

Note:

- **Never apply grease or other lubricants to the coin passages as this will cause a faster build-up of dirt and dust and possible coin jams.**
5. Re-assemble in reverse order.

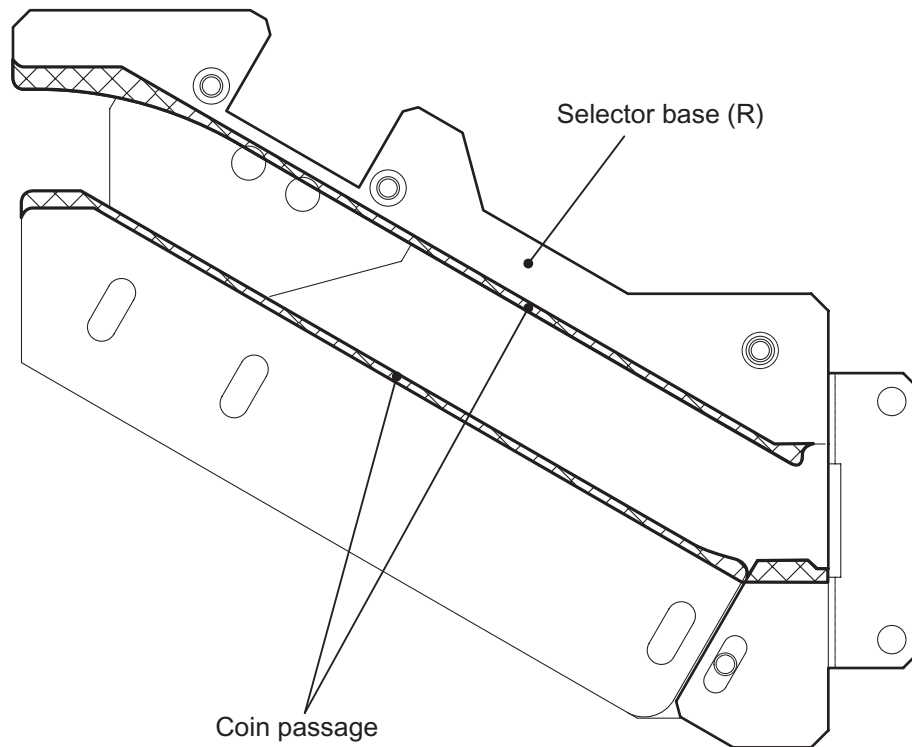

6-2-5 Cleaning the Coin Hoppers

Do not use organic solvents such as thinners, petroleum spirits etc. as these can damage the machine.

1. Remove coins from the Hopper. (see [Motor Test - page 61](#))
2. Turn OFF and disconnect the power from the game.
3. Disconnect the connector and remove the Coin Hopper.
4. While holding the Eject Lever pulled forward, lift and detach the Hopper Head from the Coin Hopper.

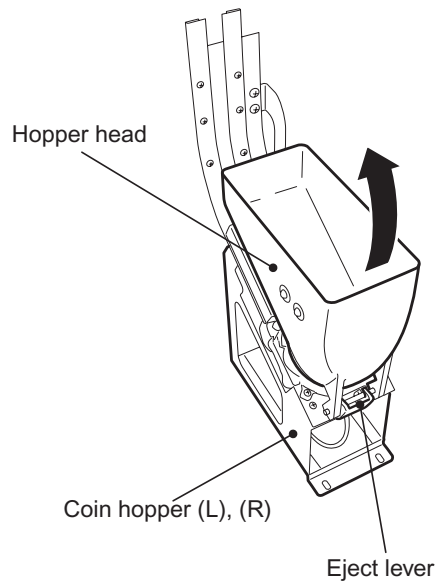

5. Wipe clean with a dry soft cloth. If it is excessively dirty, dampen a soft cloth with a neutral detergent and wipe clean.
6. Re-install in reverse order.

Note:

- **When refitting the Hopper Head, insert the hole located at the back of the Hopper Head into the protrusion on the Coin Hopper, and engage the Eject Lever for secure installation**

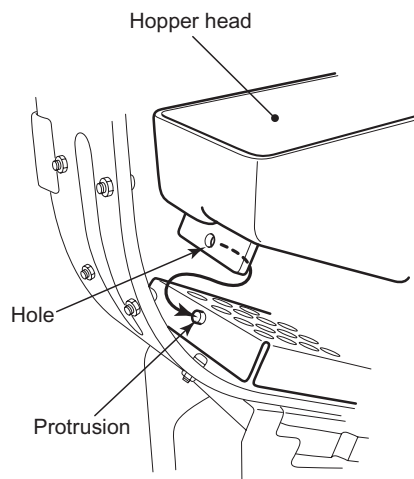

6-2-6 Collecting Coins from Hoppers and Escalators.

- If the coin hopper stops operating due to the entry of a foreign item, correct the problem by following the procedures detailed in section 7-8 page 125. Do not attempt to operate the coin hopper in an abnormal condition, as this may cause damage.
1. Set the Test switch ON.
 2. Display the I/O TEST 2/5 screen, and set “MOTOR TEST / HOPPERS (L) (R) (C)” to ON, then collect coins from the coin hoppers.
(see [Motor Test - page 61](#))

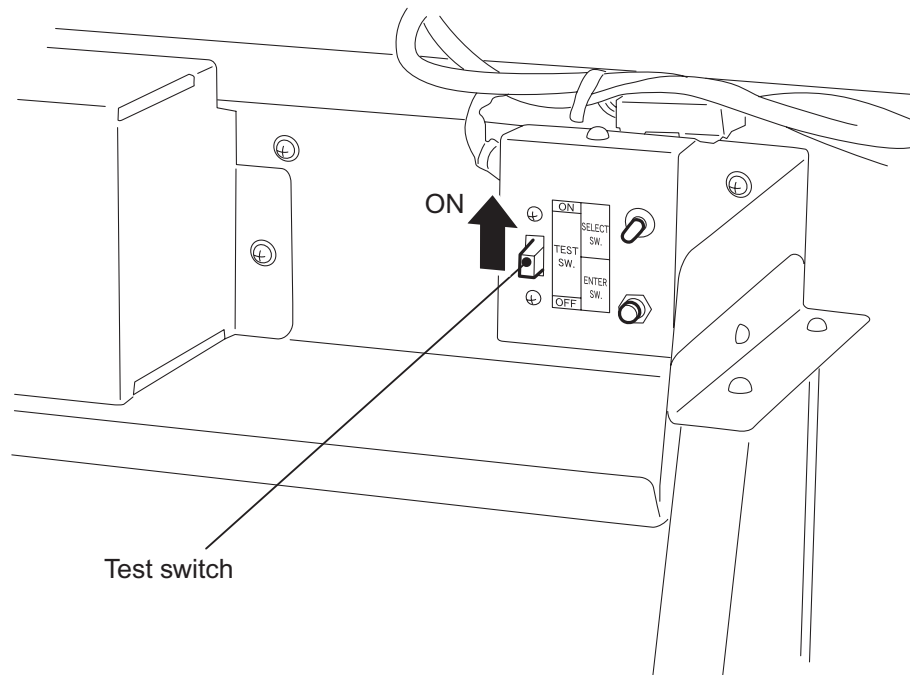

6-2-6-1 Escalator Section

Removing Actuator Covers

1. Remove 2 off Whizz nuts (M3).

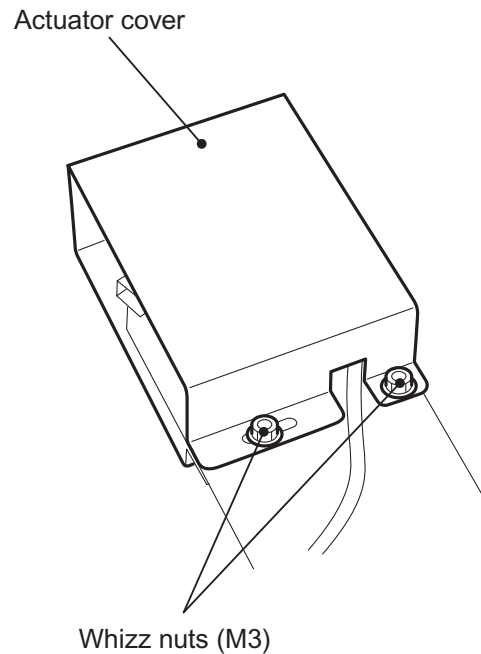

2. Loosen 1 off pozi head screw(M3x16), with flat and spring washer, and remove the covers.

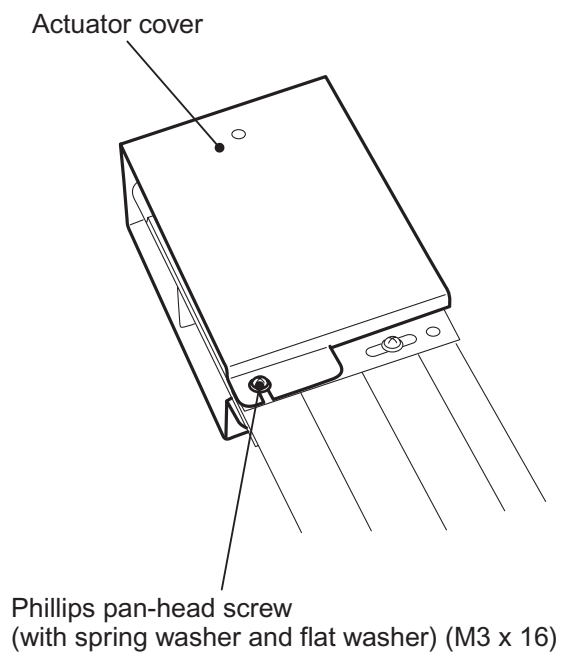

3. Re-assemble in reverse order.

Top Section

- **Do not loosen the nuts within the indicated circle on the following diagrams. Loosening or adjustment of these items may result in game failure.**
- **Do not use a screwdriver or similar object to remove jammed coins, as this could cause permanent damage to the assembly.**

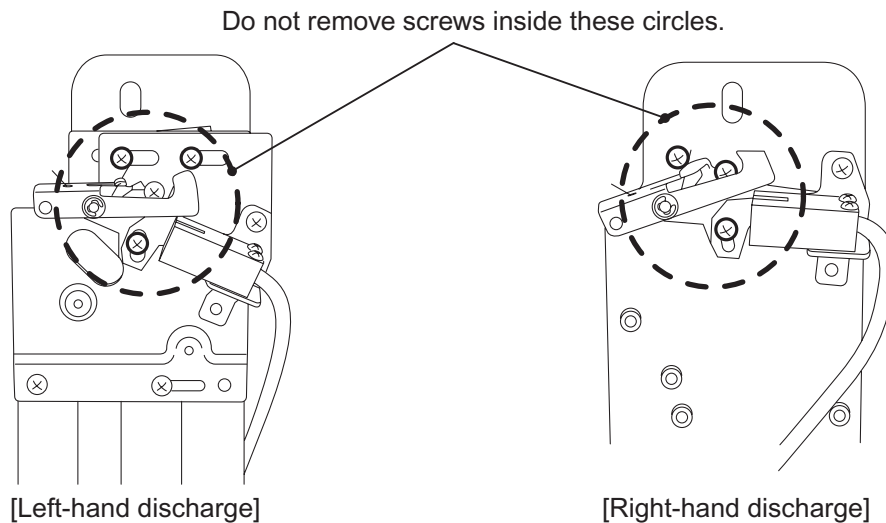

1. Loosen the 8 off pozi head screws (M3x10), with flat and spring washers, on the two Edge Plates.
Do not remove the screws.
2. Widen the gap between the Edge Plates and Back Plate, and push jammed coins with a finger in the direction of the arrow.

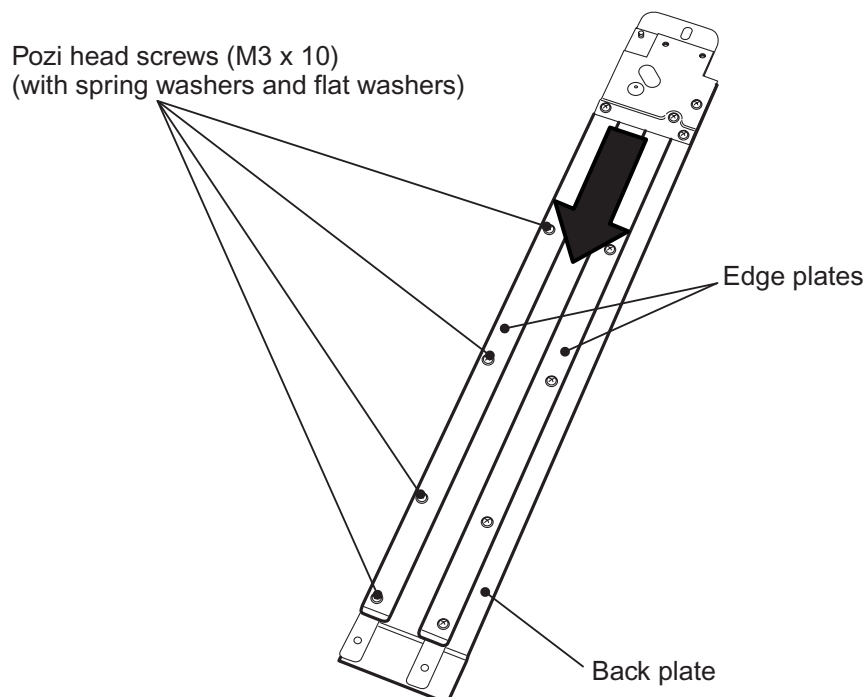

3. After coins have been removed, re-assemble in reverse order.

Middle Section

- Do not open the hinge to an angle greater than 90 degrees. Excessive opening can cause permanent damage to the hinge.
- If the Ball Receivers are removed, take care not to lose the steel balls. When reinstalling, make that the steel balls are in the centre of the coin passage.

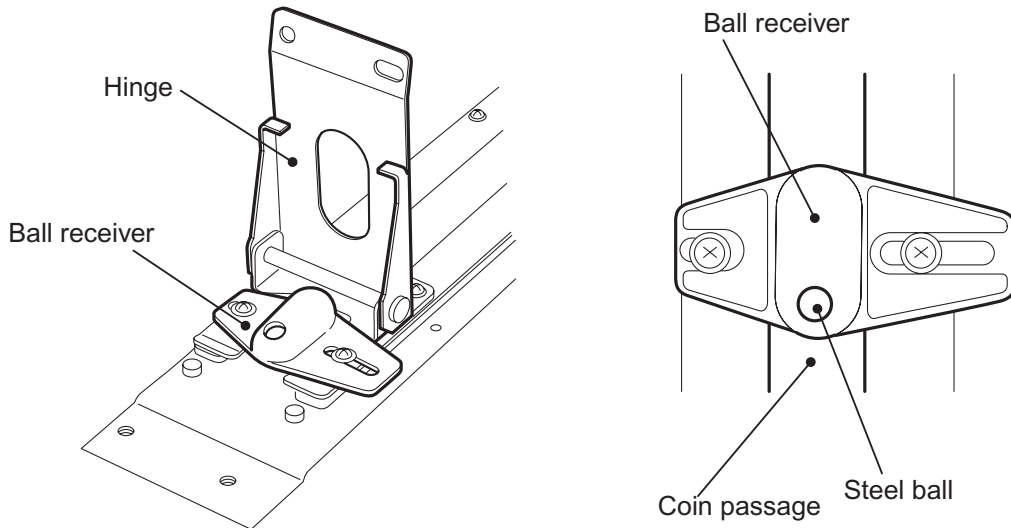

1. Loosen the 8 off pozi head screws (M3x10), with flat and spring washers, and 2 off pozi head screws (M3x12) on the two Edge Plates.
Do not remove the screws.
2. Widen the gap between the Edge Plates and Back Plate, and push jammed coins with a finger in the direction of the arrow.

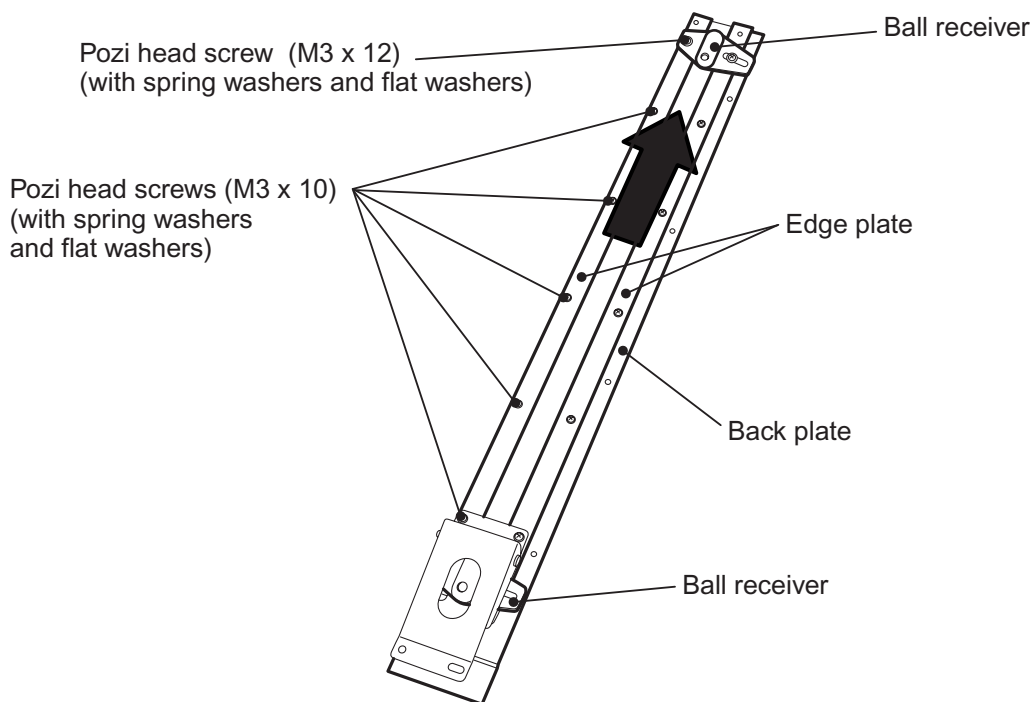

3. After coins have been removed, re-assemble in reverse order.

Hopper Section

1. Remove 1 off pozi head screw (M4x10), with flat and spring washer, and remove the cover.
Take care not to lose the washers.

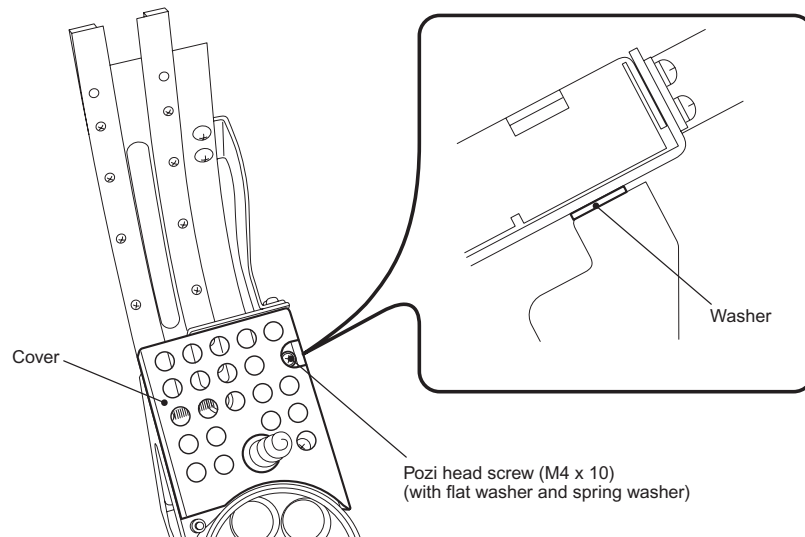

2. Loosen 10 pozi head screws (M3x10), with flat and spring washers, on the two edge plates.
Do not remove the screws.
3. Widen the gap between the Edge Plates and Back Plate, and push jammed coins with a finger in the direction of the arrow.

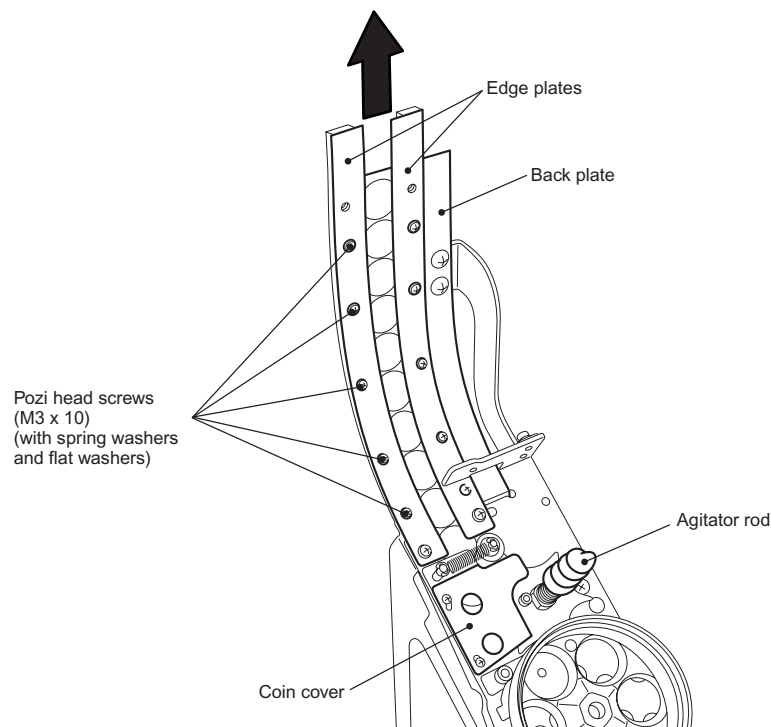

4. After coins have been removed, re-assemble in reverse order.
 - **Do not remove the Coin Cover**
 - **Do not apply excessive force to the Agitator Rod.**

6-2-6-2 Hopper

1. Remove the Hopper Head and cover. (see 6-2-5 page 80)
2. Turn the Motor Pulley to the left (counterclockwise) by hand. During this process, lightly touch the Agitator Rod with a finger. If there is excessive play between the base surface and scraper, the 2 off grub screws (M4x6) on the Wiper Boss may be loose. If they are loose, tighten them. If this does not correct the excessive gap between the Base Surface and the Scraper, contact your distributor.

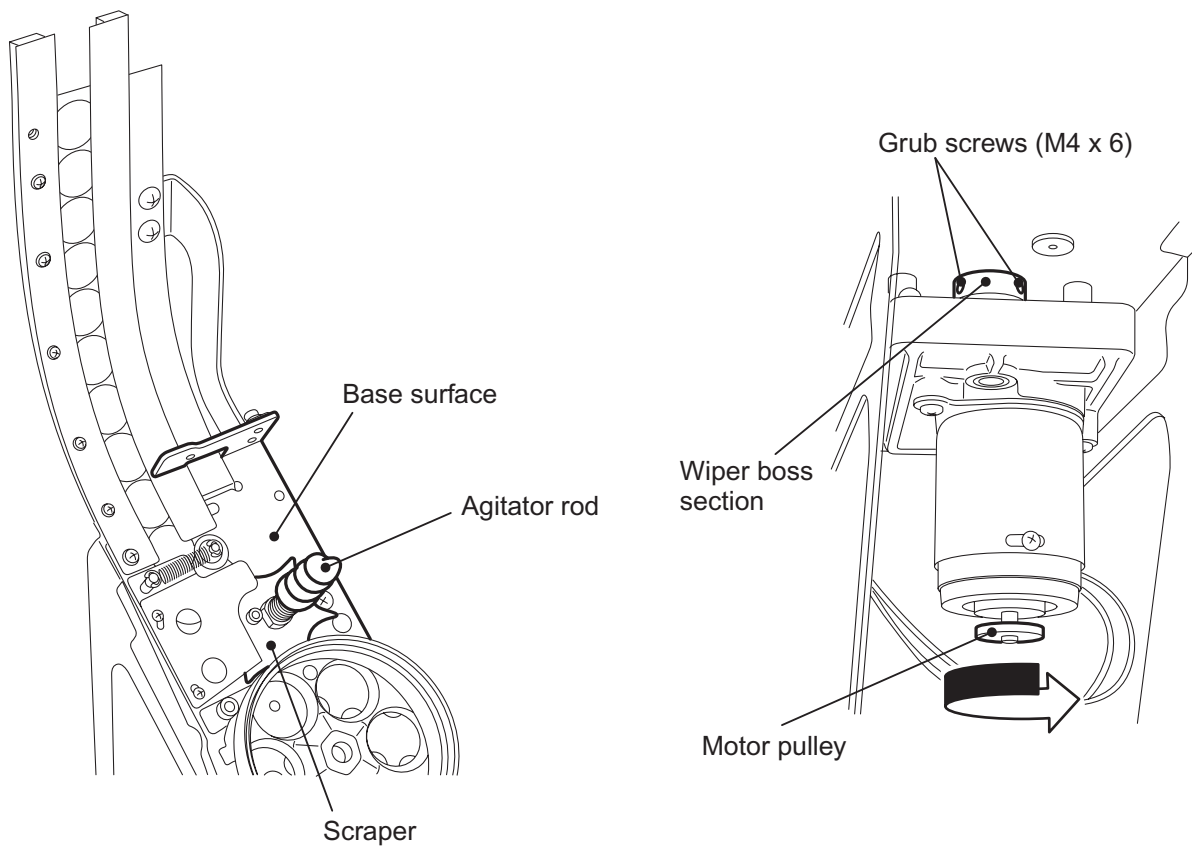

- A Hopper Empty error can be generated if coins are standing on edge in the hood section of the Hopper. Remove any coins that are on edge in the the Hopper Hood and replace them laying flat.

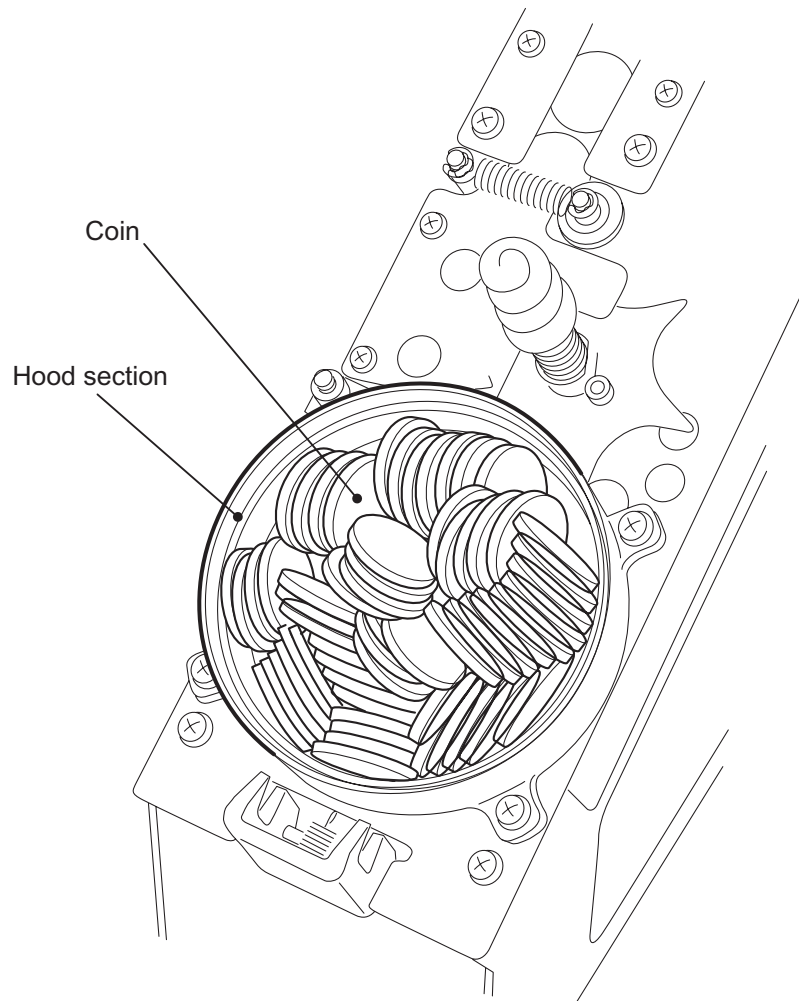

6-2-7 Cleaning the Main Panel and Main Cover

- **Do not use organic solvents such as thinners, petroleum spirits etc. as these can damage the machine.**
- **Do not move the Wiper by Hand. Moving the Wiper can result in machine malfunctions.**

1. Turn OFF and disconnect the power from the game.
2. Remove 1 off pozi head screw (M4x6) and remove the Bonus Exit.
3. Remove 6 off Pozi head screws (M4x20), 4 off pozi head screws (M4x6), 4 off Panel Spacers and remove the Main Panel Cover.

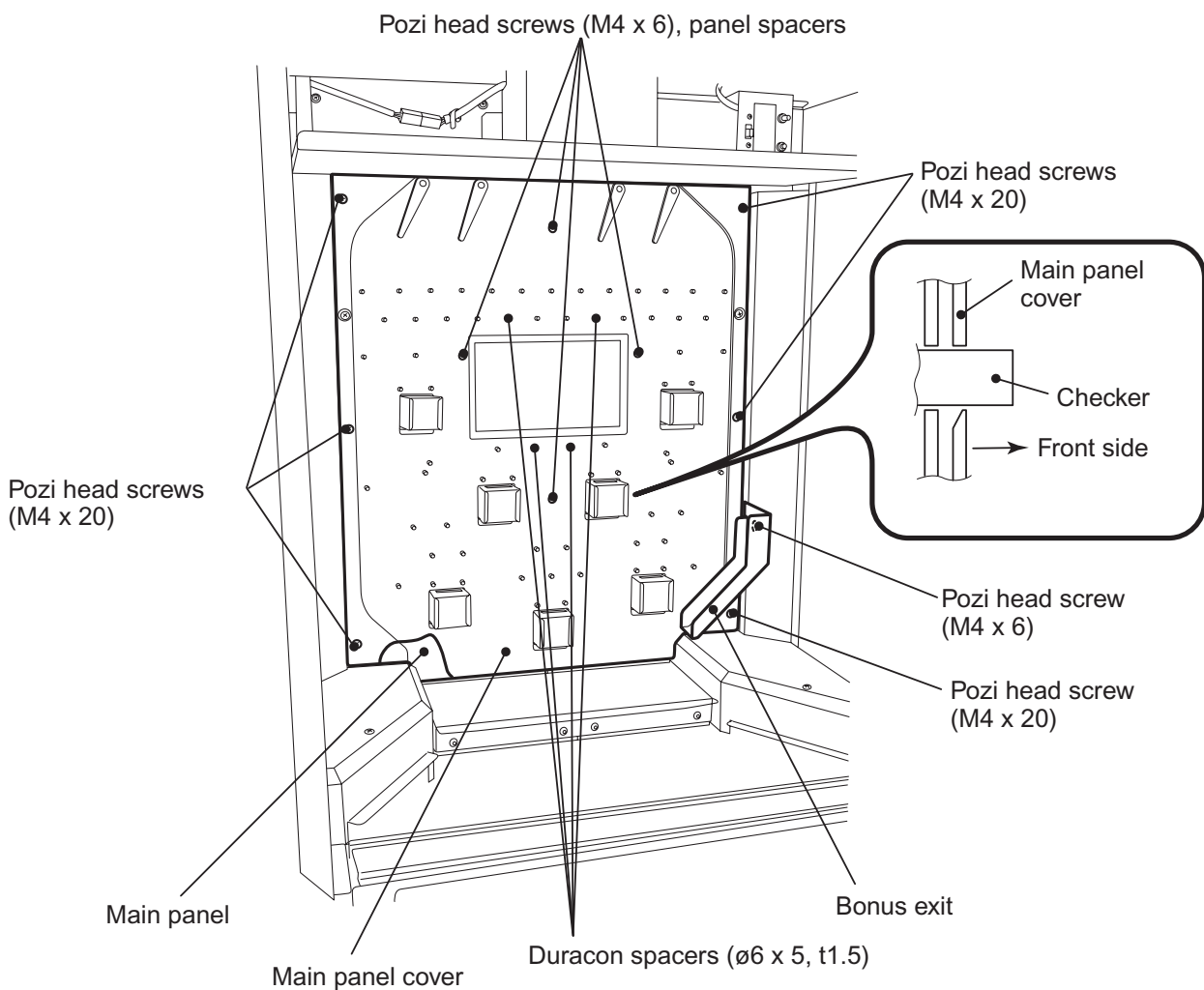

4. Wipe clean with a dry soft cloth. If they are excessively dirty, dampen a soft cloth with a neutral detergent and wipe clean.
 5. Re-install in reverse order.
- **Do not forget to install the Panel Spacers during re-assembly.**
 - **Be sure to check that the front and rear sides of the Main Panel are correct when reinstalling. The upper parts of the opening for the Checker on the Front side are flat.**

6-2-8 Cleaning the Dust Box

- **If non conforming coins are inserted, the sorting mechanism of the Coin Selector Assy rejects them and sends them to the Dust Boxes. Regularly remove any coins from the Dust Boxes.**
1. Unlock and open the Maintenance door.
 2. Collect any rejected coins from the right and left Dust Boxes.
 3. Close and lock the Maintenance Door.

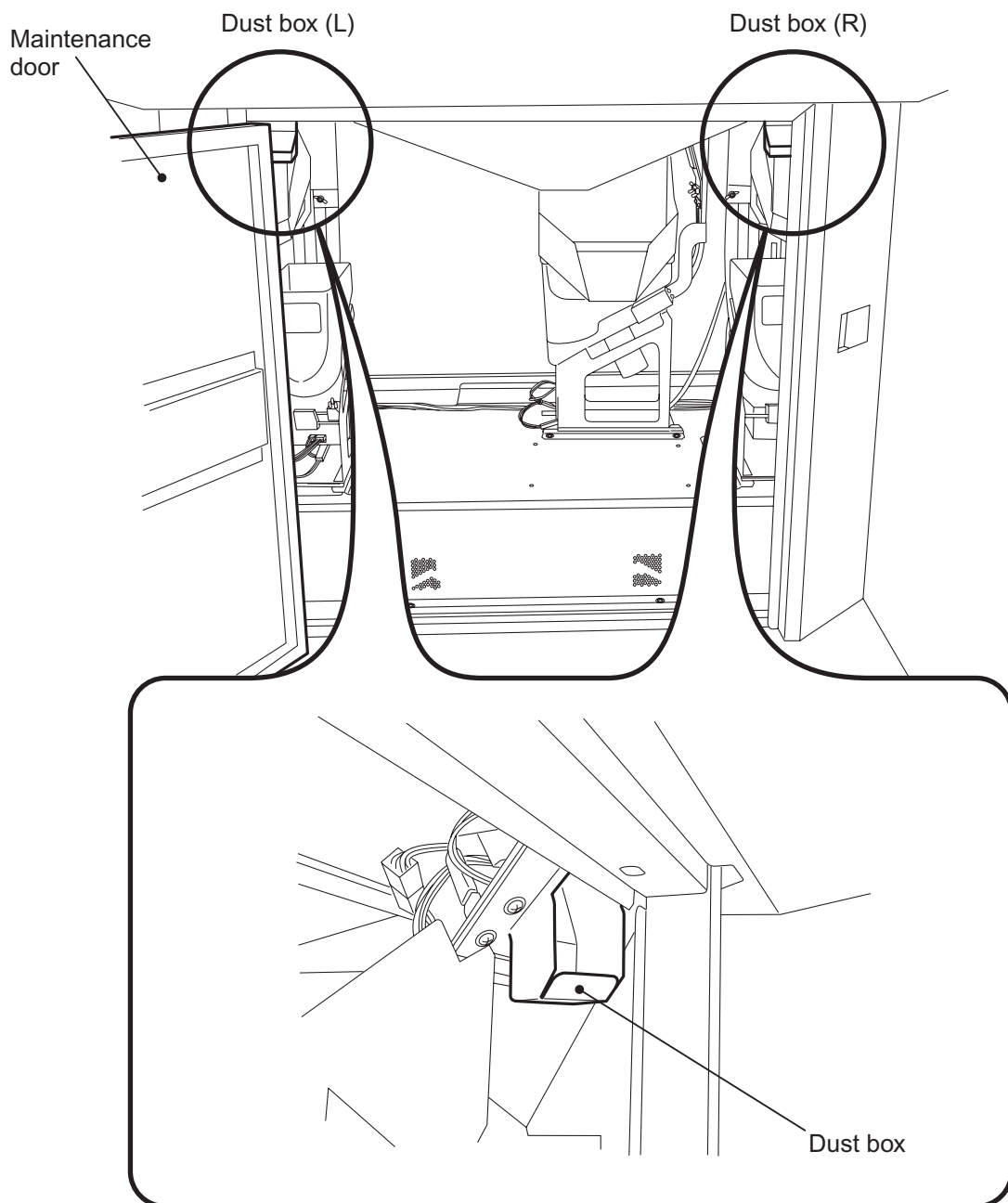

6-2-9 Removing Jammed Coins from the Panel Assy

1. Unlock and open the Playfield Door.
2. Insert the Coin Ejection Pin into the hole on the Main Panel Cover that is closest to the jammed coin, then gently pull the Main Panel Cover forwards to dislodge the jammed coin.
 - If the above fails to dislodge the coin, remove the Main Panel Cover and remove the jammed coins. ([see 6-2-7 page 88](#))

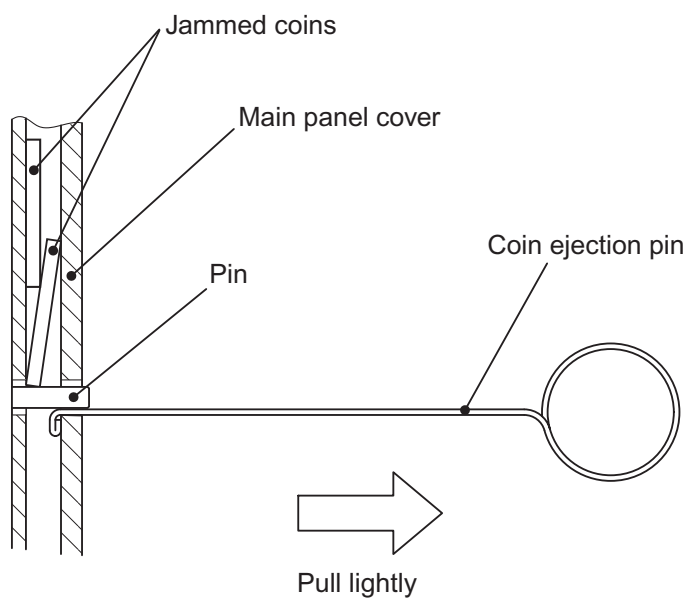

3. Close and lock the Playfield Door.

6-3-3 List of Error Indications

Error Code	Error Message	Main Cause	Description of Error	Action
1-1	HOPPER (C) RUNAWAY	Malfunction of coin hopper (C)	This error is generated when the payout sensor reacts while the coin hopper (C) is non-operational	Replace the coin hopper (C)
		Malfunction of MGEXIO PC board		Replace the MGEXIO PC board
1-2	HOPPER (C) OVERPAID	Malfunction of coin hopper (C)	This error is generated when the payout sensor reacts while the coin hopper (C) is in non-operation	Replace the coin hopper (C)
1-3	HOPPER (C) EMPTY	No coin in coin hopper (C). jammed coins	This error is generated when the payout sensor does not react during the operation of coin hopper (C)	Add coins to the coin hopper (C), or remove jammed coins Malfunction of coin hopper (C)
		Malfunction of coin hopper (C)	This error is generated when the motor for the coin hopper (C) is faulty or the fuse for the coin hopper is blown.	Replace the coin hopper (C)
1-4	HOPPER (C) TIMEOUT	Jammed coins in coin hopper (C) causing payout sensor to remain ON	This error is generated when the payout sensor for coin hopper (C) remains ON for a certain period of time.	Remove coins jammed near the escalator outlet.
1-11	HOPPER (L) RUNAWAY	Malfunction of coin hopper (L)	This error is generated when the payout sensor reacts while the coin hopper (L) is in non-operation	Replace the coin hopper (L)
		Malfunction of MGEXIO PC board		Replace the MGEXIO PC board
1-12	HOPPER (L) OVERPAID	Malfunction of coin hopper (L)	This error is generated when the payout sensor reacts while the coin hopper (L) is non-operational	Replace the coin hopper (L)
1-13	HOPPER (L) EMPTY	No coin in coin hopper (L). jammed coins	This error is generated when the payout sensor does not react during the operation of coin hopper (L)	Add coins to the coin hopper (L), or remove jammed coins Malfunction of coin hopper (L)
		Malfunction of coin hopper (L)	This error is generated when the motor for the coin hopper (L) is faulty or the fuse for the coin hopper is blown.	Replace the coin hopper (L)
1-14	HOPPER (L) TIMEOUT	Jammed coins in coin hopper (L) causing payout sensor to remain ON	This error is generated when the payout sensor for coin hopper (L) remains ON for a certain period of time.	Remove coins jammed near the escalator outlet.
1-21	HOPPER (R) RUNAWAY	Malfunction of coin hopper (R)	This error is generated when the payout sensor reacts while the coin hopper (R) is non-operational	Replace the coin hopper (R)
		Malfunction of MGEXIO PC board		Replace the MGEXIO PC board
1-22	HOPPER (R) OVERPAID	Malfunction of coin hopper (R)	This error is generated when the payout sensor reacts while the coin hopper (R) is non-operational	Replace the coin hopper (R)
1-23	HOPPER (R) EMPTY	No coin in coin hopper (R). jammed coins	This error is generated when the payout sensor does not react during the operation of coin hopper (R)	Add coins to the coin hopper (R), or remove jammed coins Malfunction of coin hopper (R)
		Malfunction of coin hopper (R)	This error is generated when the motor for the coin hopper (R) is faulty or the fuse for the coin hoppers is blown.	Replace the coin hopper (R)
1-24	HOPPER (R) TIMEOUT	Jammed coins in coin hopper (R) causing payout sensor to remain ON	This error is generated when the payout sensor for coin hopper (R) remains ON for a certain period of time.	Remove coins jammed near the escalator outlet.

Error Code	Error Message	Main Cause	Description of Error	Action
2-11	COIN SENSOR (L) TIME OUT	Dirty coin sensor (L2). Malfunction of coin sensor (L2).	This error is generated when the coin passing time of the coin sensors (L1) and (L2) is longer than specified.	Clean the coin passage. Replace the coin sensors
2-12	COIN SENSOR (L1) JAM	Jammed coins on top of coin sensor (L1)	This error is generated when a coin or other item is blocking the coin sensor (L1)	Remove jammed coins, and clean the coin passage.
2-13	COIN SENSOR (L2) JAM	Jammed coins on top of coin sensor (L2)	This error is generated when a coin or other item is blocking the coin sensor (L2)	Remove jammed coins, and clean the coin passage.
2-16	COIN SENSOR (L) REVERSE	Jammed coins in Coin Selector (L) Assy	This error is generated when a coin passes through the coin sensor (L2) without passing through the coin sensor (L1)	Remove jammed coins, and clean the coin passage
		Reverse flow of coin. Insertion of non conforming coin.		In the case of reverse flow of coin or insertion of non-conforming coin, set the Test switch ON, and then OFF.
2-21	COIN SENSOR (R) TIME OUT	Dirty coin sensor (R2). Malfunction of coin sensor (R2).	This error is generated when the coin passing time of the coin sensors (R1) and (R2) is longer than specified.	Clean the coin passage. Replace the coin sensors
2-22	COIN SENSOR (R1) JAM	Jammed coins on top of coin sensor (R1)	This error is generated when a coin or other item is blocking the coin sensor (R1)	Remove jammed coins, and clean the coin passage.
2-23	COIN SENSOR (R2) JAM	Jammed coins on top of coin sensor (R2)	This error is generated when a coin or other item is blocking the coin sensor (R2)	Remove jammed coins, and clean the coin passage.
2-26	COIN SENSOR (R) REVERSE	Jammed coins in Coin Selector (R) Assy	This error is generated when a coin passes through the coin sensor (R2) without passing through the coin sensor (R1)	Remove jammed coins, and clean the coin passage
		Reverse flow of coin. Insertion of non conforming coin.		In the case of reverse flow of coin or insertion of nonconforming coin, set the Test switch ON, and then OFF.
3-1	BACKUP MEMORY (MEM (N))	Faulty contact of MEM (N) PC board	Data in the backup memory is damaged.	Check the PC board connection.
		Faulty MEM (N) PC board	Data in the backup memory is damaged	Contact your distributor.
3-2	BACKUP MEMORY (MEGEXIO)	Faulty contact of MGEXIO PC board		Check the PC board connection
		Malfunction of MGEXIO PC board		Contact your distributor
3-3	TILT	Tilt detected due to external vibration		Set the Test switch ON and then OFF.

Error Code	Error Message	Main Cause	Description of Error	Action
5-1	CHECKER SENSOR (1)	Jammed coins in checker unit (1). Dirty checker sensor Malfunction of checker sensor	This error is generated when there is an obstruction between the checker sensor and prism, or there is a malfunction	If there are jammed coins, remove them. If the checker sensor is dirty, clean the sensor. If the checker sensor is malfunctioning, replace the sensor.
5-2	CHECKER SENSOR (2)	Jammed coins in checker unit (2). Dirty checker sensor Malfunction of checker sensor	This error is generated when there is an obstruction between the checker sensor and prism, or there is a malfunction	If there are jammed coins, remove them. If the checker sensor is dirty, clean the sensor. If the checker sensor is malfunctioning, replace the sensor.
5-3	CHECKER SENSOR (3)	Jammed coins in checker unit (3). Dirty checker sensor Malfunction of checker sensor	This error is generated when there is an obstruction between the checker sensor and prism, or there is a malfunction	If there are jammed coins, remove them. If the checker sensor is dirty, clean the sensor. If the checker sensor is malfunctioning, replace the sensor.
5-4	CHECKER SENSOR (4)	Jammed coins in checker unit (4). Dirty checker sensor Malfunction of checker sensor	This error is generated when there is an obstruction between the checker sensor and prism, or there is a malfunction	If there are jammed coins, remove them. If the checker sensor is dirty, clean the sensor. If the checker sensor is malfunctioning, replace the sensor.
5-5	CHECKER SENSOR (5)	Jammed coins in checker unit (5). Dirty checker sensor Malfunction of checker sensor	This error is generated when there is an obstruction between the checker sensor and prism, or there is a malfunction	If there are jammed coins, remove them. If the checker sensor is dirty, clean the sensor. If the checker sensor is malfunctioning, replace the sensor.
5-6	CHECKER SENSOR (6)	Jammed coins in checker unit (6). Dirty checker sensor Malfunction of checker sensor	This error is generated when there is an obstruction between the checker sensor and prism, or there is a malfunction	If there are jammed coins, remove them. If the checker sensor is dirty, clean the sensor. If the checker sensor is malfunctioning, replace the sensor.
5-7	CHECKER SENSOR (7)	Jammed coins in checker unit (7). Dirty checker sensor Malfunction of checker sensor	This error is generated when there is an obstruction between the checker sensor and prism, or there is a malfunction	If there are jammed coins, remove them. If the checker sensor is dirty, clean the sensor. If the checker sensor is malfunctioning, replace the sensor.
5-8	PUSHER MOTOR SENSOR	Faulty pusher motor. Malfunction of pusher sensor. Disconnected pusher sensor connector.	This error is generated when the pusher sensor does not detect the passing of the pusher crank for a certain period of time.	If there is any foreign item stuck in the pusher unit, remove it. If the pusher sensor is disconnected, connect the connector. If the flange bushing of the pusher is worn, replace it.
5-9	SUB CPU STOP	Malfunction of MGEXIO PC board		Contact your distributor
5-10	SUB CPU STOP (RESET)	Malfunction of MGEXIO PC board		Contact your distributor
5-11	MGEXIO	Faulty contact of MGEXIO PC board. Malfunction of MGEXIO PC board		Check the connection of the MGEXIO PC board. Contact your distributor
5-12	DIVIDER SOLENOID SENSOR (L)	Faulty divider solenoid (L)	This error is generated when the divider solenoid sensor (L) is OFF during divider solenoid operation.	Check the connection of the divider solenoid connector.
		Dirty divider solenoid sensor (L)		Clean the divider solenoid sensor.
		Malfunction of divider solenoid (L)		Replace the divider solenoid sensor.
5-13	DIVIDER SOLENOID SENSOR (R)	Faulty divider solenoid (R)	This error is generated when the divider solenoid sensor (R) is OFF during divider solenoid operation.	Check the connection of the divider solenoid connector.
		Dirty divider solenoid sensor (R)		Clean the divider solenoid sensor.
		Malfunction of divider solenoid (R)		Replace the divider solenoid sensor.

6-3-4 Resetting Errors

When an Error message is displayed on the LCD screen, follow the resetting procedure described below.

After an error has been reset, the game usually returns to the condition immediately before the error occurred.

- If a time-limited mini-game was being played at the time of error generation, the mini-game restarts from the beginning (with full remaining time) when the error is reset.
 - When a BACKUP MEMORY (MEM (N)) or BACKUP MEMORY (MGEXIO) error is reset, all data including the income date, security data, hardware data, error history and settings are cleared, and the settings returned to factory defaults.
1. Check the error indication to find out the cause of the problem.
 2. Check and correct the cause of the error.
 3. Unlock and open the Playfield Door.
 4. Reset the error by turning the Test switch, located inside the Playfield Door, to ON and then OFF.
 5. Close and lock the Playfield Door.

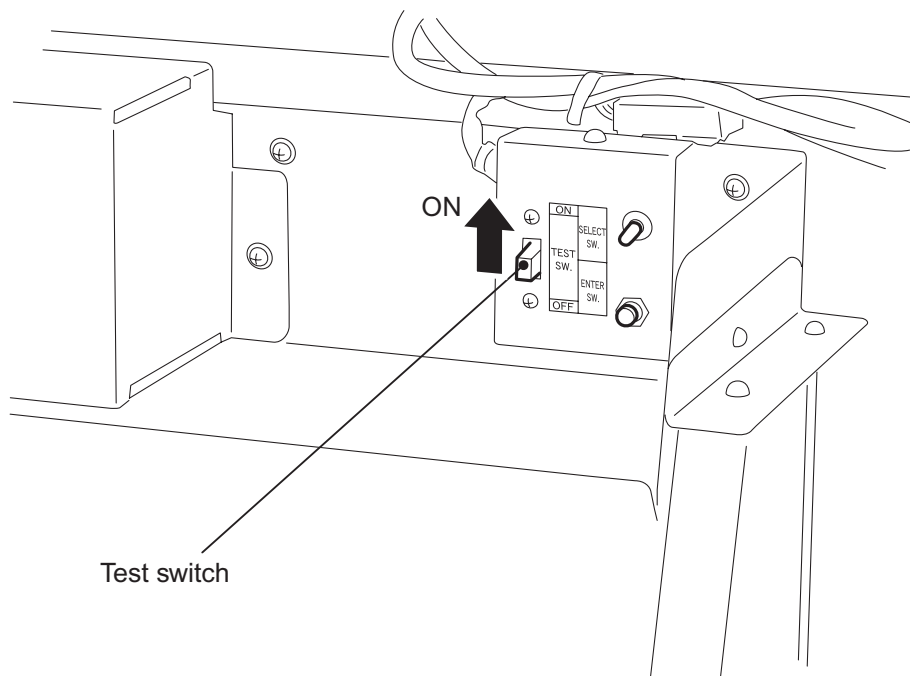

7. REPLACING PARTS

7-1 Lamps

Fluorescent Lamps and Starters.

Fluorescent lamps can become hot. Take care when removing lamps.

1. Turn the power switch, located on the rear of the cabinet, OFF.
2. Unlock and open the Playfield Door.
3. Replace the Fluorescent Tube (20w) and/or Starter.
4. Close and relock the Playfield Door.

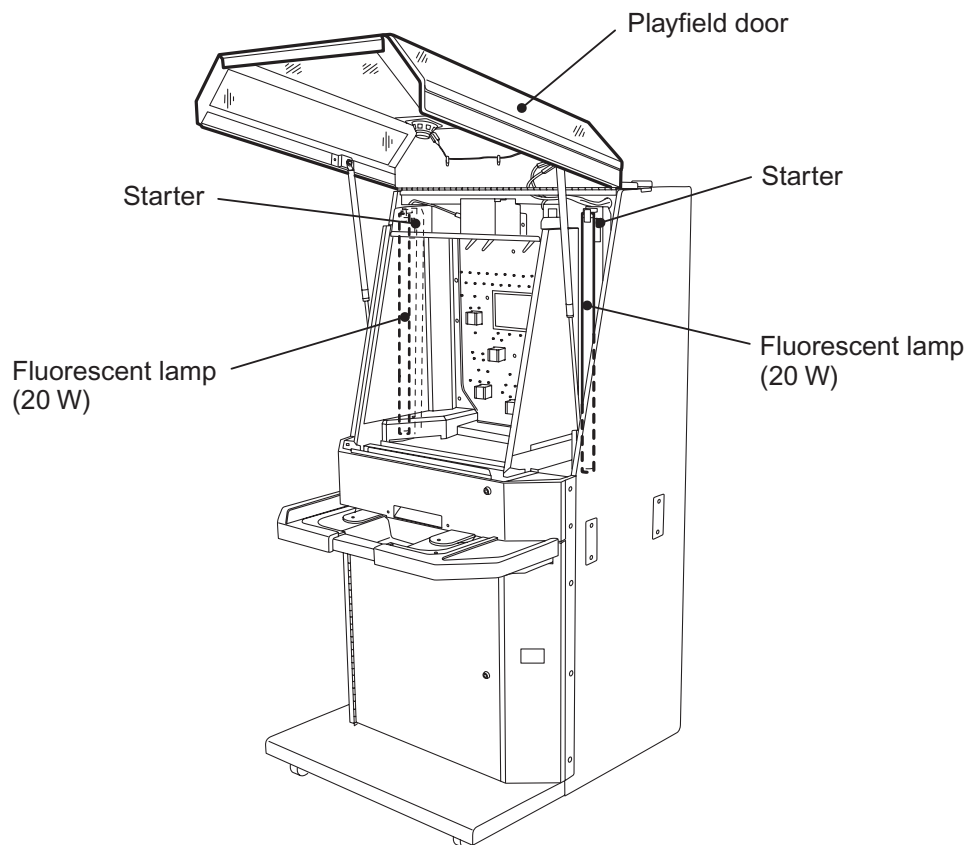

Halogen Lamp

Halogen Lamps remain hot even after the power has been switched off. To prevent burns, ensure that the lamp has cooled before replacing.

1. Turn the power switch, located on the rear of the cabinet, OFF.
2. Unlock and open the Playfield Door.
3. Remove 2 off cap screws (M4x6), and remove the Halogen Lamp Cover B.

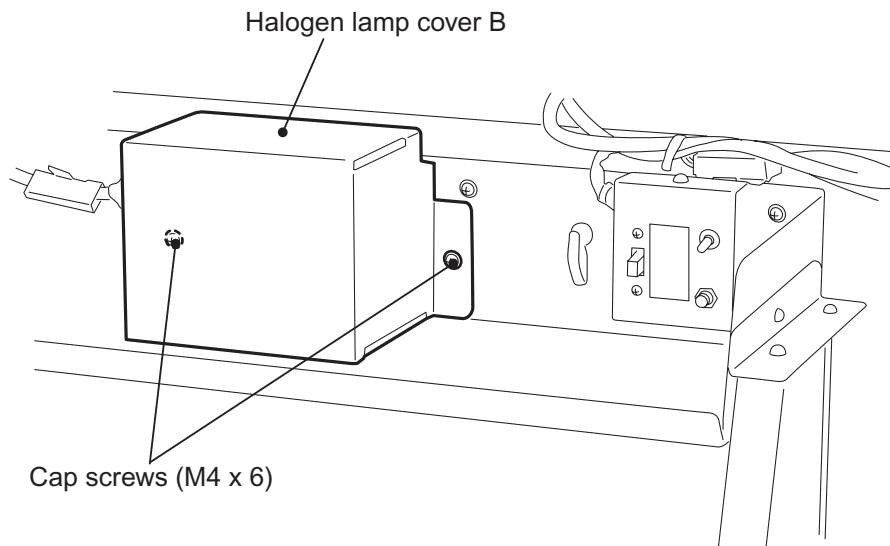

4. Turn the Halogen Lamp anti-clockwise to remove.

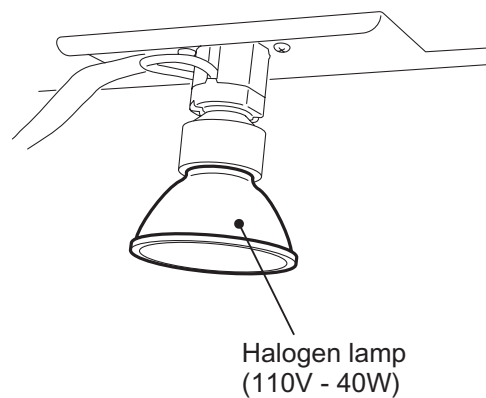

5. Replace the Lamp (110V - 40W)
6. Re-assemble in reverse order.

Win Lamp

1. Turn the power switch, located on the rear of the cabinet, OFF.
2. Unlock and open the Playfield Door.
3. Disconnect the connector, remove 4 off whizz nut (M4) and remove the Lamp Cover.

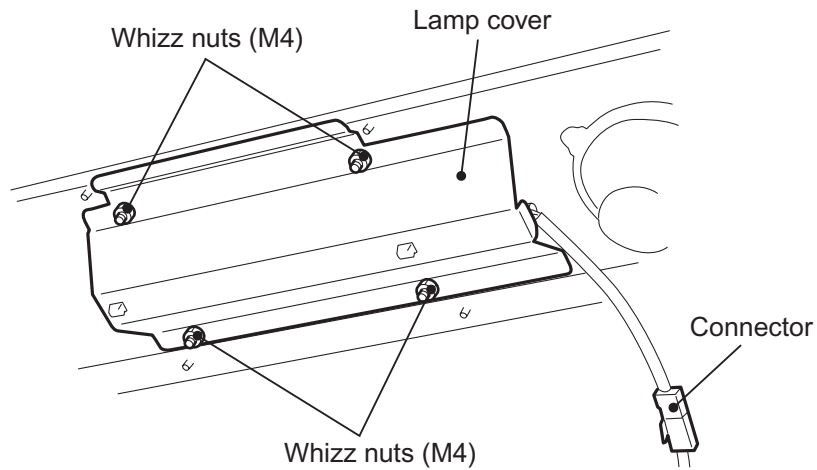

4. Replace the Win Lamp.
5. Re-assemble in reverse order.
When re-assembling, align the end of the Win Lamp with the left holder, and then press the Win Lamp into position by pushing at both ends.

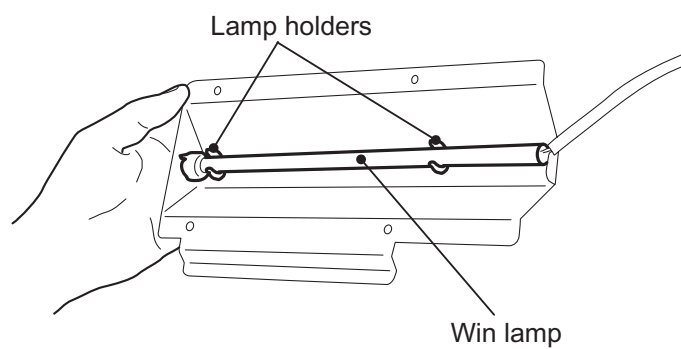

7-2 PC Board Base

- **Pc Boards can be easily damaged by static electricity. If a person charged with static electricity handles a PCB, electronic components on the board can be damaged. Before handling a PCB, touch an earthed metal surface to release the electrostatic charge from the body.**

The Game PC Board Assembly comprises of System 10 PCB, MGEX IO PCB and MEM(N) PCB.

1. Switch the power to the game OFF.
2. Unlock and open the Maintenance Door.
3. Remove 3 off pozi head screws (M4x20) and remove the PC Board Cover.

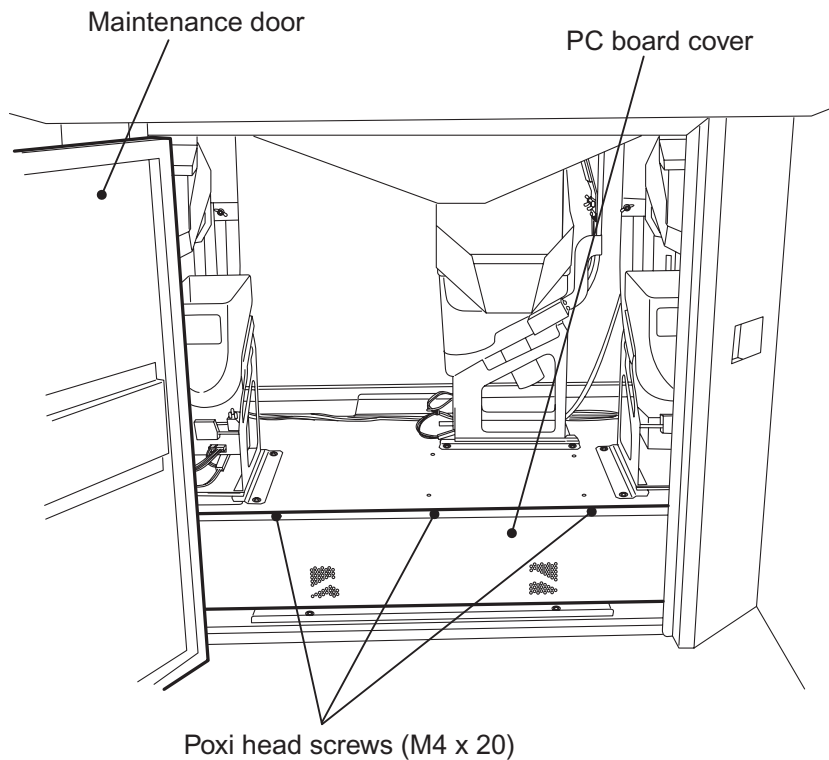

- Loosen the 2 off pozi head screws (M4x20), disconnect the 6 off connectors, and remove the PC board base.

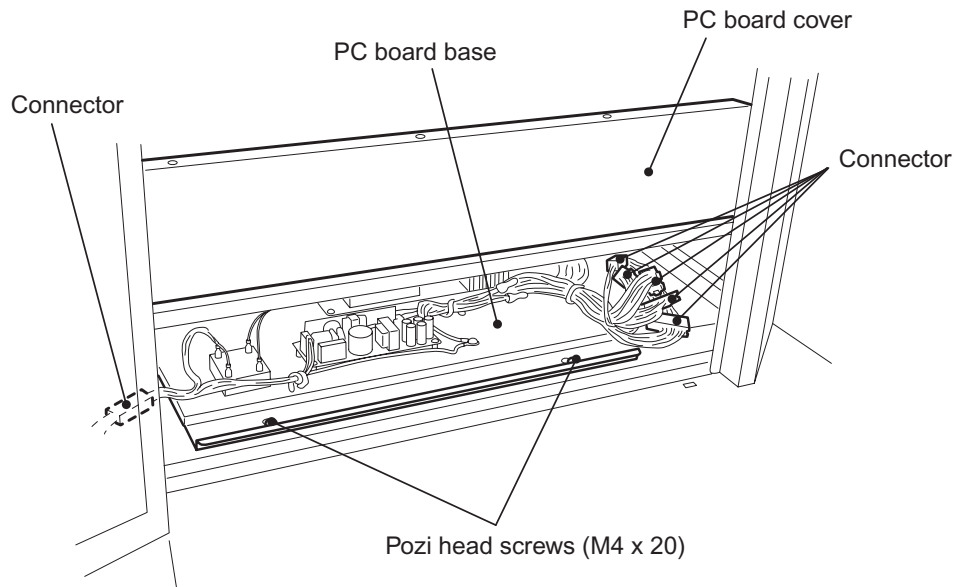

Game PCB Assy

- Disconnect 7 off connectors, remove 4 off pozi head screws (M3x6), and remove the Game PCB assy,

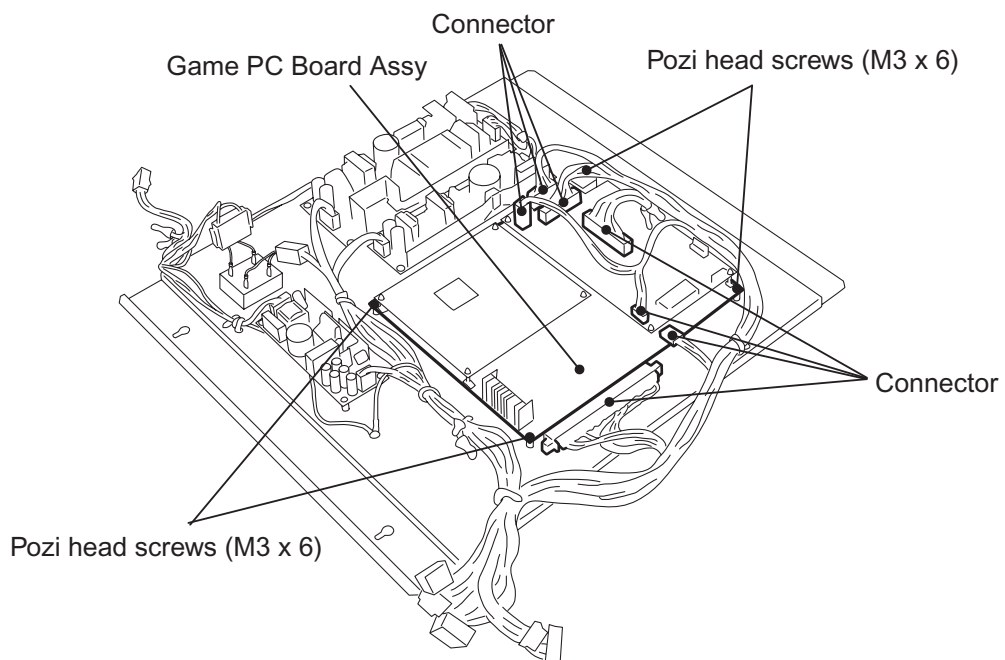

- Re-assemble in reverse order.
When re-assembling, ensure that connectors are fully engaged.

MGEX IO PCB

1. Disconnect the 5off connectors, disengage the 6off locking supports, and remove the MGEX IO PCB.

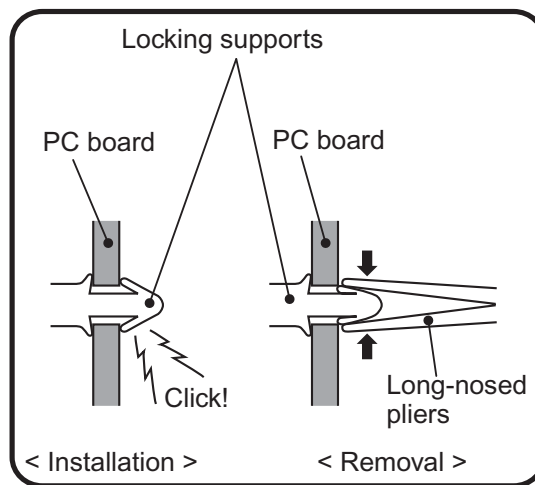
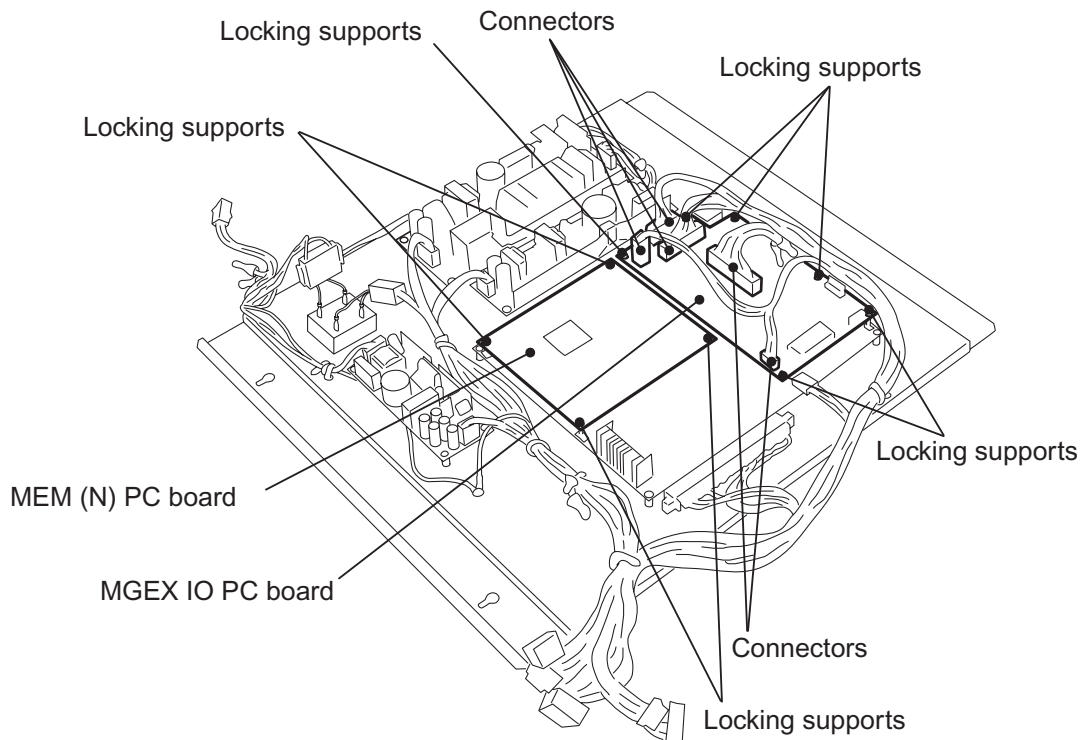

2. Re-assemble in reverse order.
When re-assembling, ensure that connectors are fully engaged.

MEM (N) PCB

1. Disengage the 4off locking supports, and remove the MEM (N) PCB.
2. Re-assemble in reverse order.

7-3 Playfield Assembly

7-3-1 Replacing the Pusher Motor

- **Before replacing the Pusher Motor, remove all coins from the playfield.**

1. Switch the power to the game OFF.
2. Remove the maintenance panel from the rear of the cabinet.
3. Disconnect 1off connector, remove 4off pozi head screws (M4x6), and remove the Pusher Motor complete with Mounting Bracket by sliding them to the side.

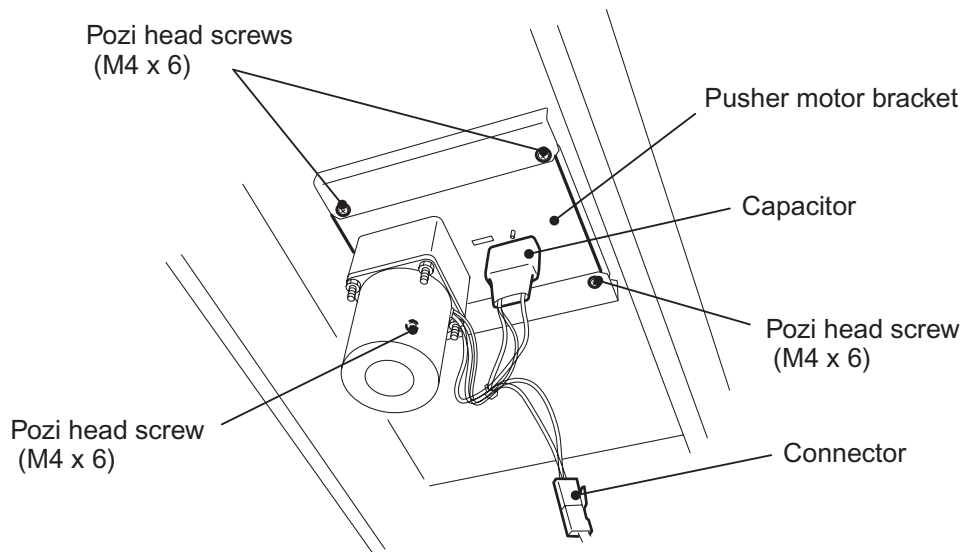

4. Disconnect 1off connector, remove 1off phillips pan head screw (M4x14), and remove the capacitor.

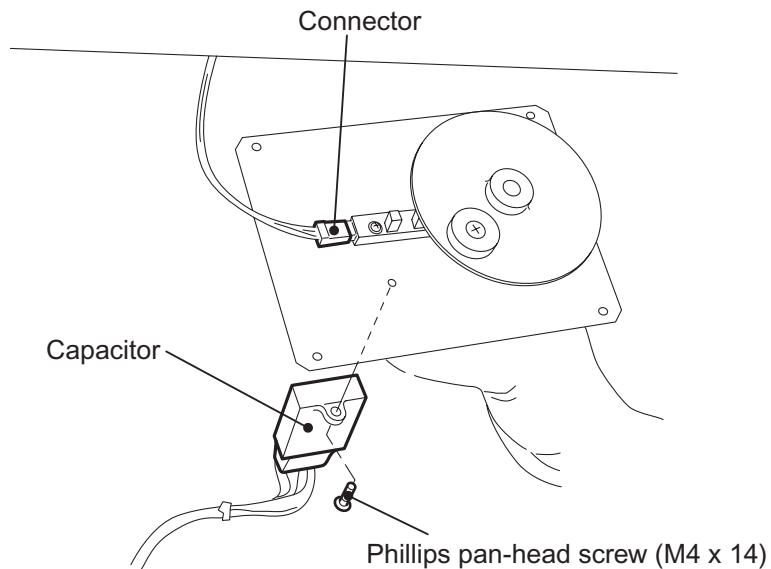

5. Loosen the 2 off double-point screws (M4x5) and remove the Pusher Crank.
6. Remove 4 off phillips head screws (M4x65) and remove the Motor.

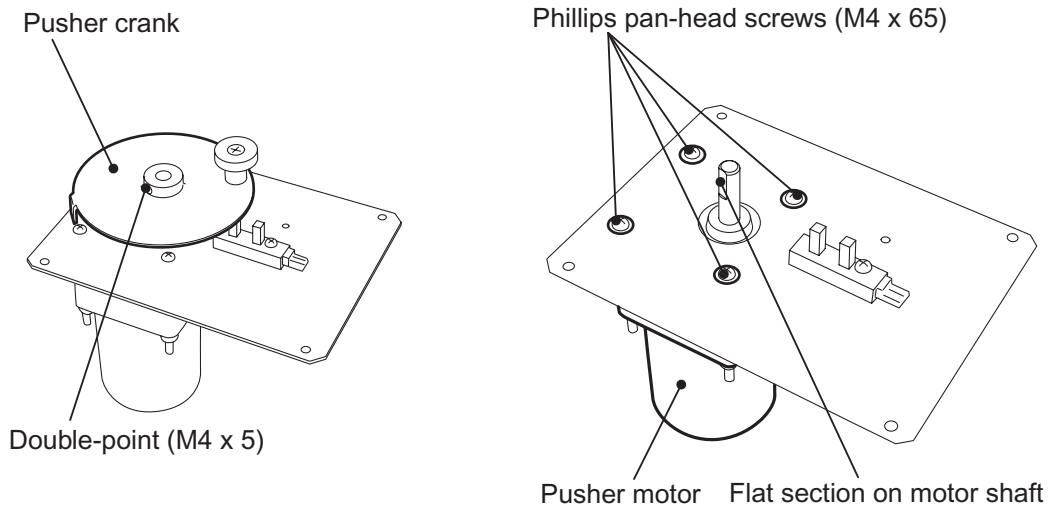

7. Re-assemble in reverse order.
 - **When re-assembling, ensure that the connectors are fully engaged.**
 - **Make sure that one of the double-point screws is engaged with the flat of the motor shaft.**
 - **Ensure that the end of the motor shaft is flush with the pusher crank end face.**

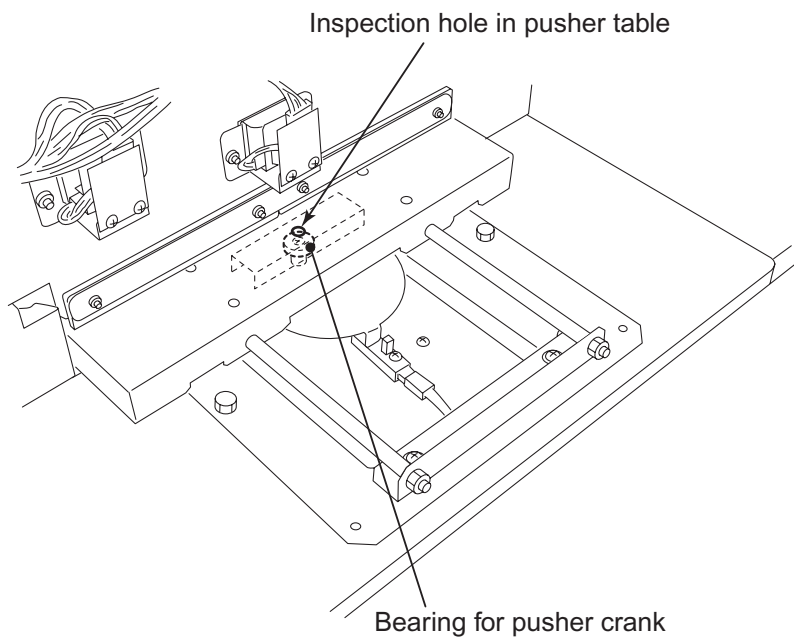

7-3-2 Replacing the Pusher Sensor

1. Switch the power to the game OFF.
2. Remove the maintenance panel from the rear of the cabinet.
3. Disconnect 1off connector, remove 1off pozi head screws (M4x14), and remove the Pusher Sensor.

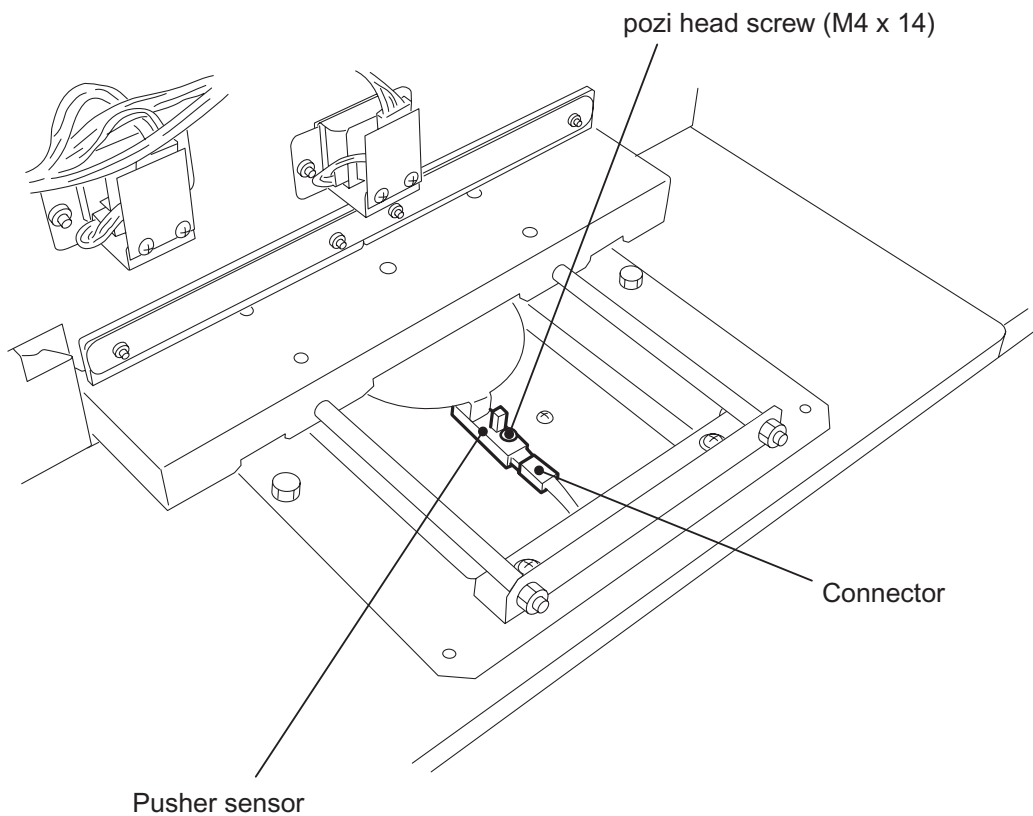

4. Re-assemble in reverse order.
5. After re-assembly, conduct a pusher sensor test.
(see [Motor Test page 61](#))

7-3-3 Replacing the Flange Bushing

1. Switch the power to the game OFF.
2. Unlock and open the Playfield Door.
3. Remove 1 off phillips screw (M4x6) and remove the Bonus Exit.

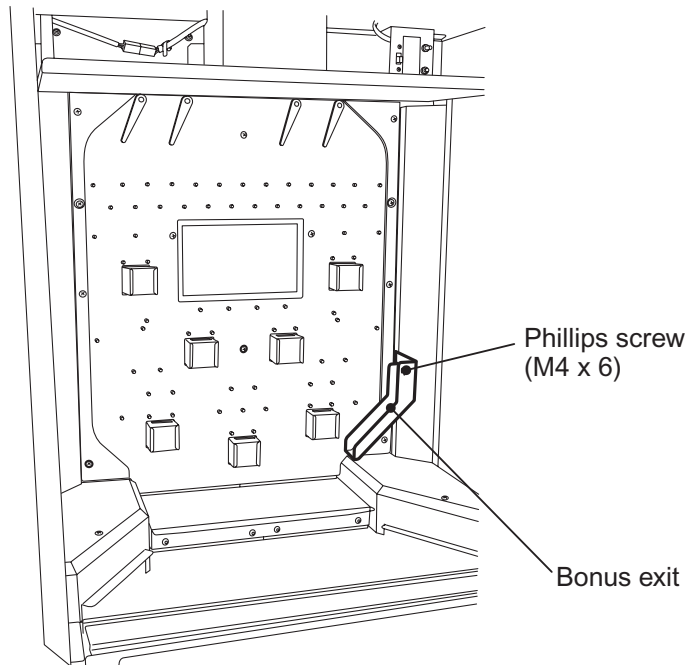

4. Unlock and open the Maintenance Door.
5. Disconnect 3 off connectors, remove 6 off wing bolts, and separate the Coin Hoppers (C), (L), (R) from their escalators.

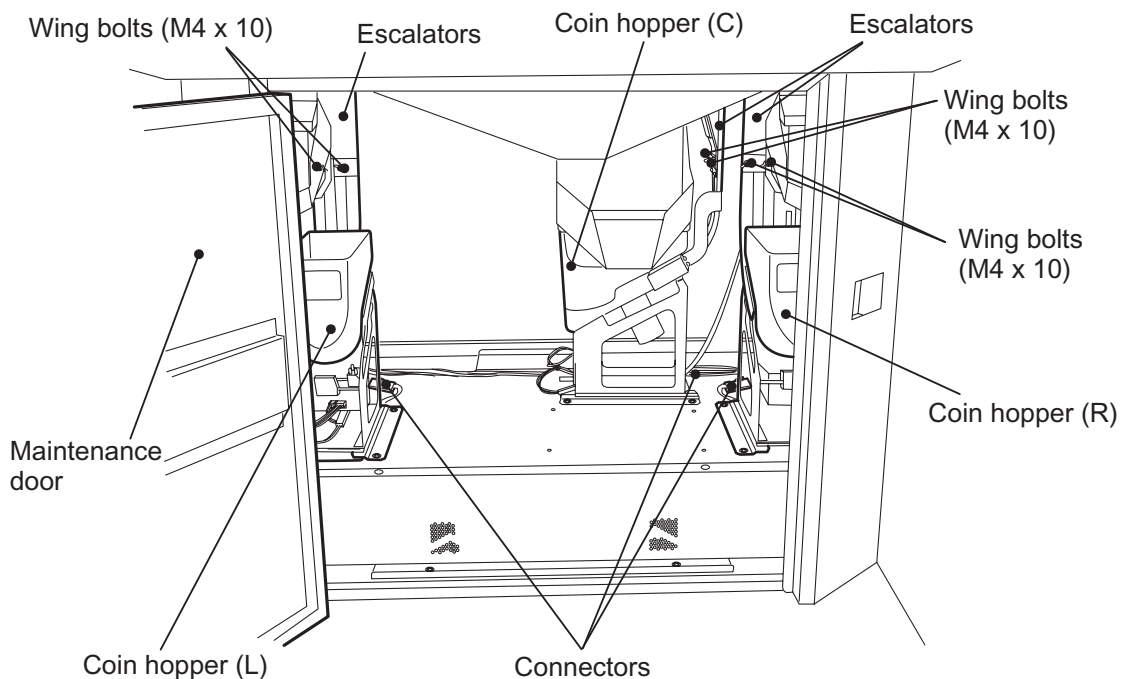

6. Remove the maintenance panel from the rear of the cabinet.
7. Remove one pozi head screw (M4x6) and remove the escalator from the coin hopper (C)
Remove 4 off flange socket head screws (M4x10) and remove the Chute Hopper Holders B and the escalators from the coin hoppers (L), (R).
** In this step, be sure to hold each escalator to prevent it falling.*

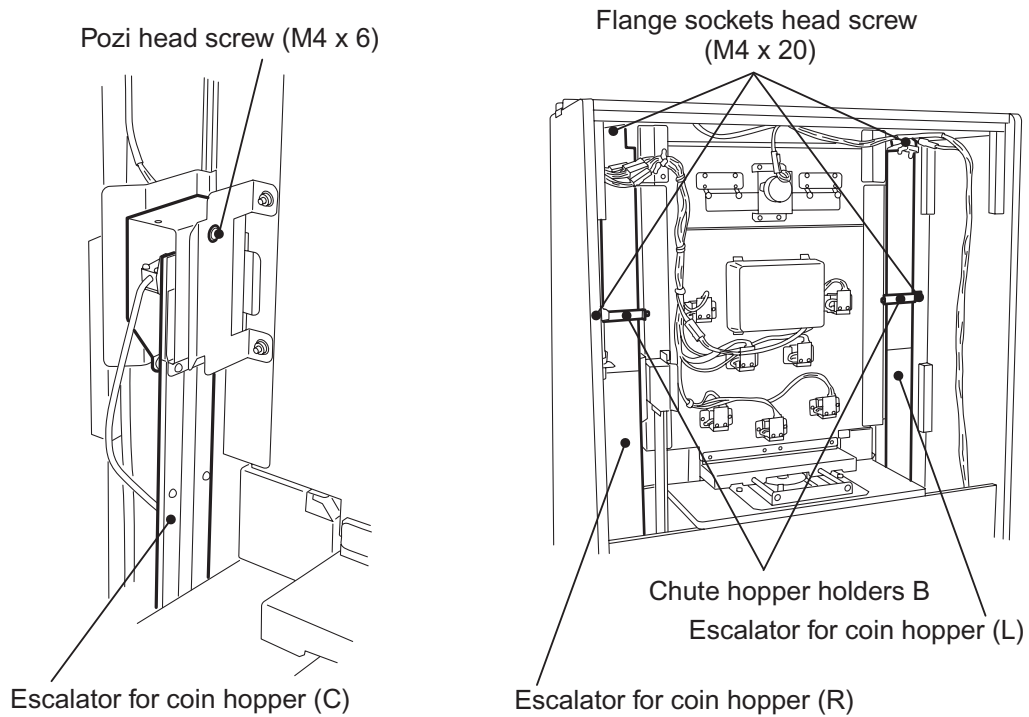

8. Disconnect 4 off connectors, remove 6 off flange socket head screws (M4x20), and remove the Panel Assy

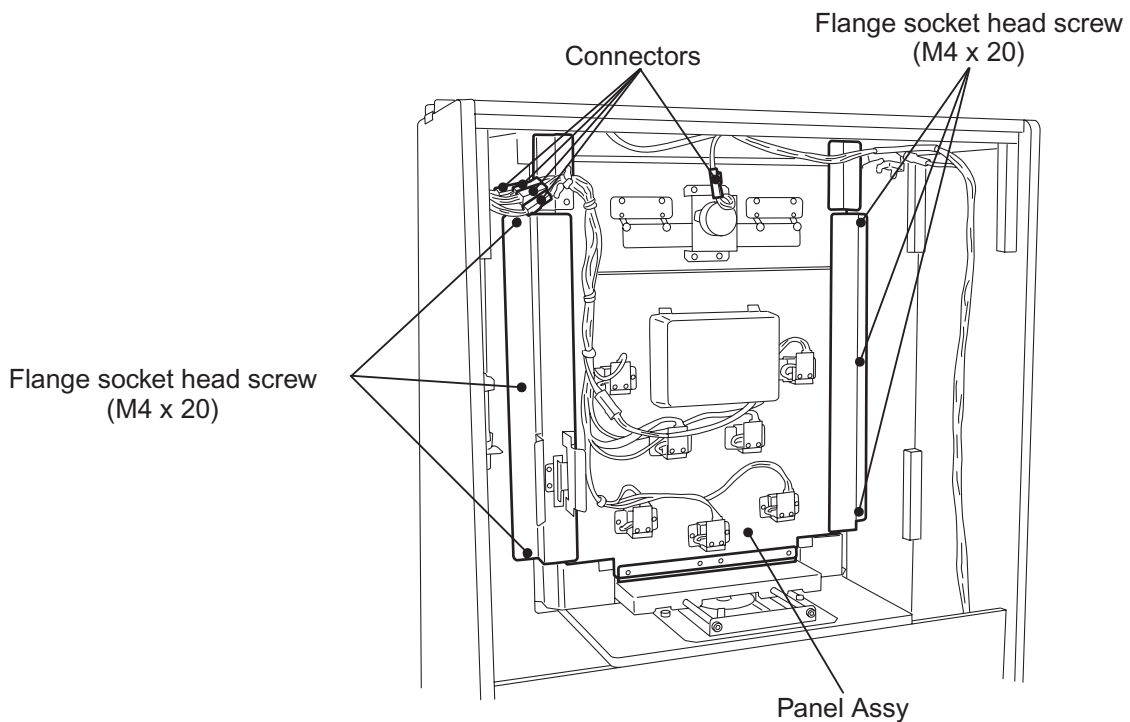

9. Remove 2 off pozi head screws (M5x10) and remove the Pusher Table and Pusher Guide Bracket.
10. Pull out the Pusher Guide Bracket from the Pusher Table.
11. Remove 2 off countersunk washer nuts (M4), detach the bearing supports, and remove the Flange Bushings.

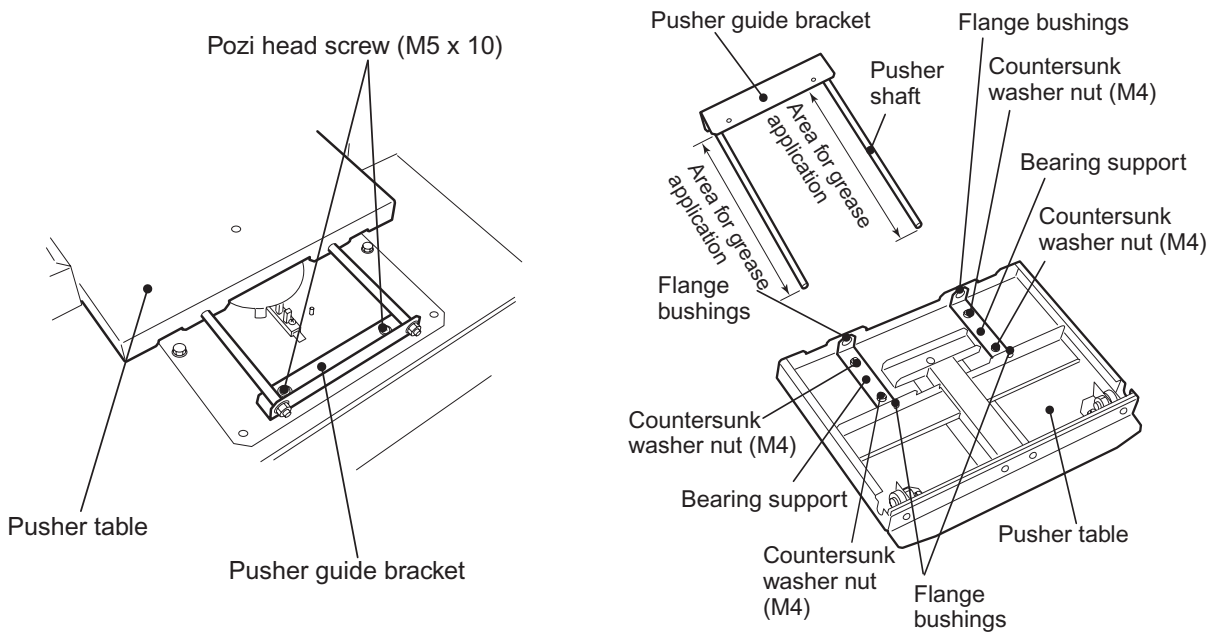

12. Re-assemble in reverse order.

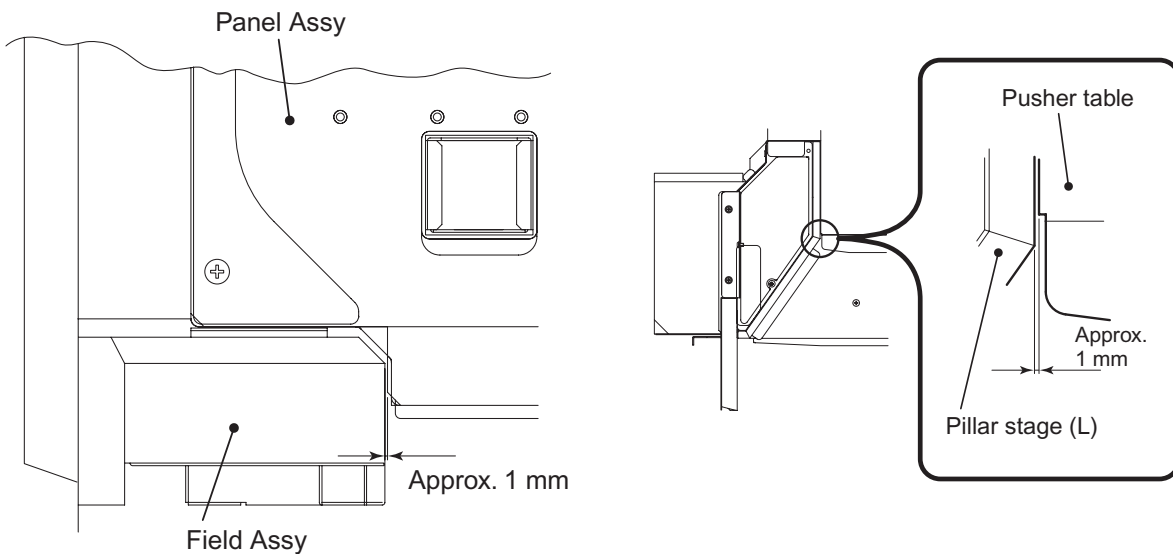

- **When re-assembling make sure that the gap, (approx 1mm), between the Panel Assy and Field Assy is the same on the right and left sides before tightening the screws.**
- **When re-assembling, apply a lithium based grease to the pusher shaft.**
- **When re-assembling, adjust the gap, (approx 1mm), between the pusher table and pillar stages (L), (R) to be the same on the right and left sides, and ensure that coins do not fall in to the gaps.**

7-4 Panel Assembly

7-4-1 Replacing the Sensor PC Board

- **Pc Boards can be easily damaged by static electricity. If a person charged with static electricity handles a PCB, electronic components on the board can be damaged. Before handling a PCB, touch an earthed metal surface to release the electrostatic charge from the body.**
1. Switch the power to the game OFF.
 2. Remove the maintenance panel from the rear of the cabinet.
 3. Disconnect 3off connectors, remove 2off pozi head screws (M3x6), and remove the Sensor PC Board.

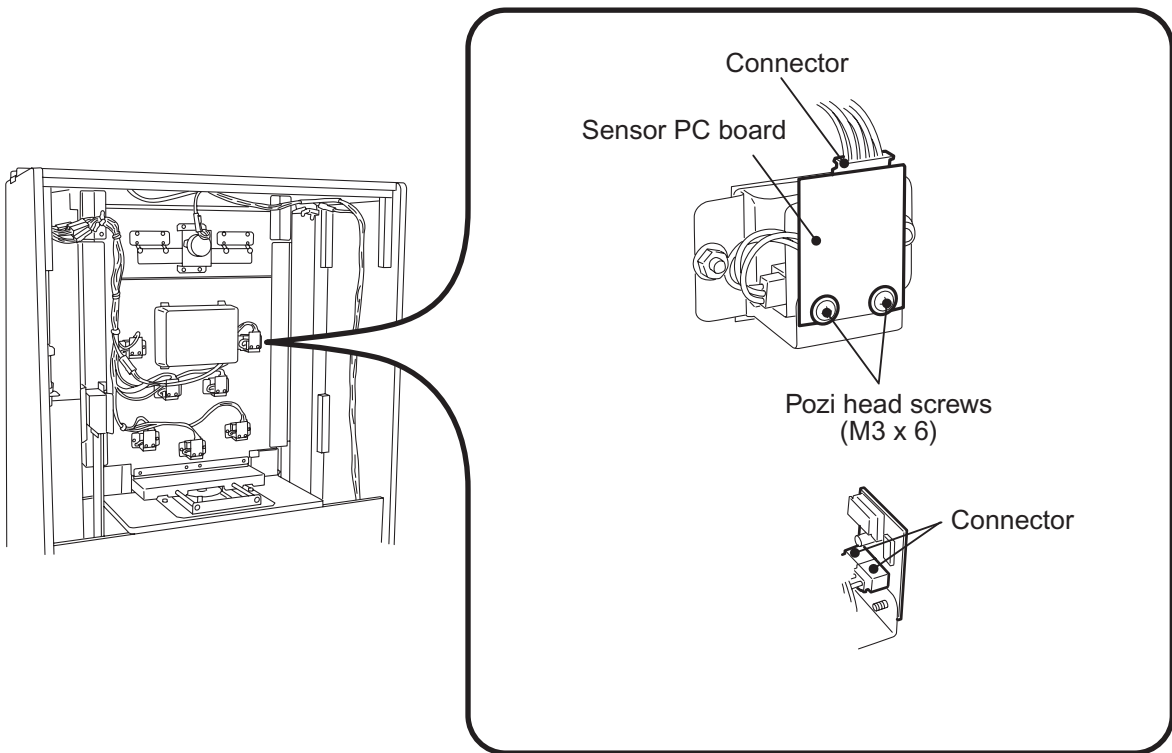

4. Re-assemble in reverse order.

7-4-2 Replacing the Checker Unit

1. Switch the power to the game OFF.
2. Remove the maintenance panel from the rear of the cabinet.
3. Disconnect the connector, remove 2 off Whizz nuts (M4) and remove the checker unit

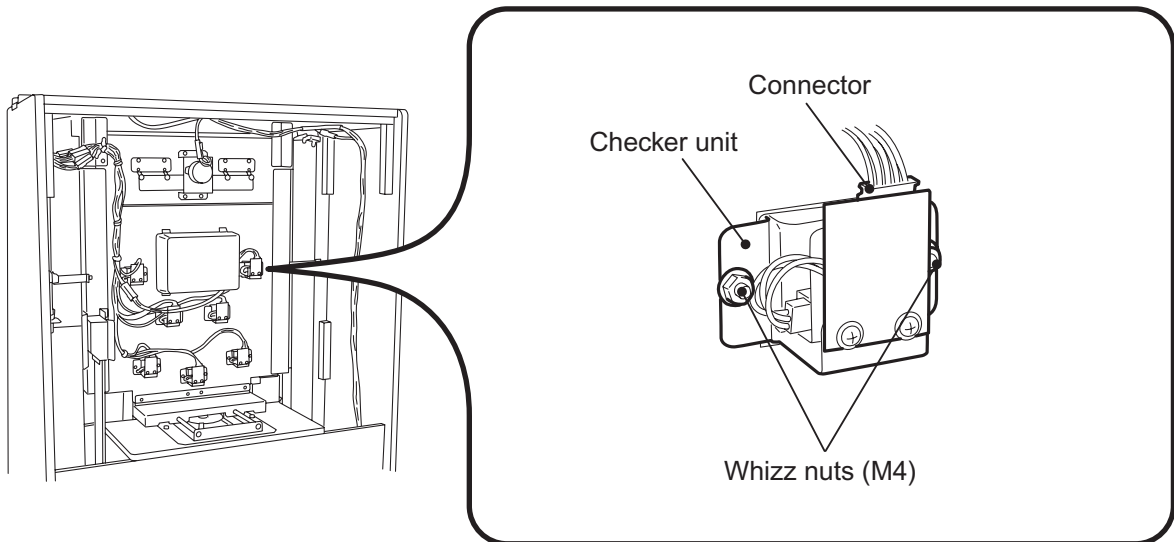

4. Re-assemble in reverse order.

7-4-3 Replacing the Checker Sensors

1. Remove the Checker Unit. (see 7-4-2 page 110)
2. Remove the Checker Cover.
3. Disconnect the connector, remove the Checker Sensor by squeezing the claws and remove the Sensor.

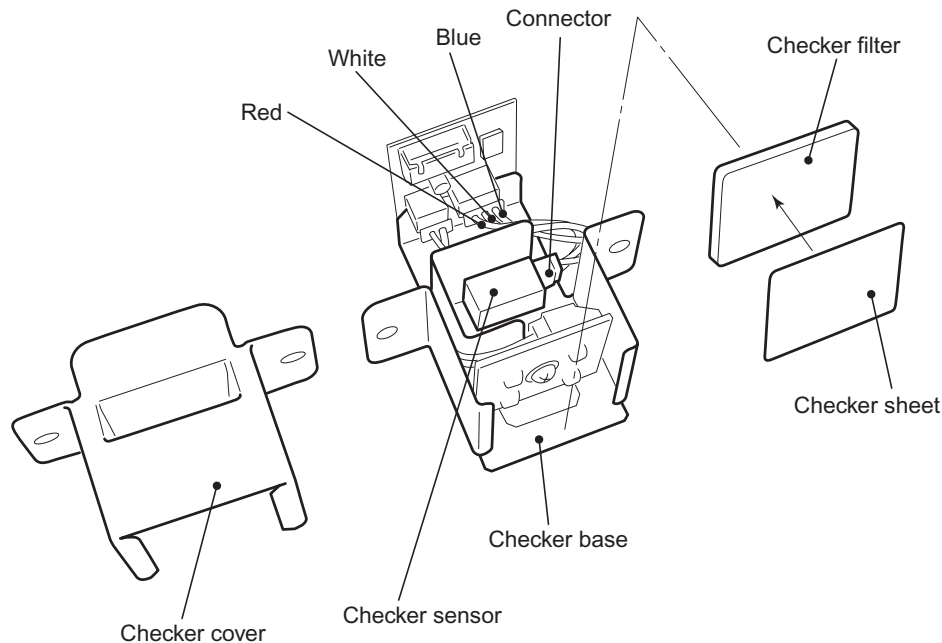

4. Re-assemble in reverse order.
- **When re-assembling, make sure that the tongue is inserted in the slot of the checker cover and that there is a gap of 4.5mm or more on the inside of the tongue.**
 - **When re-assembling, face the shiny side of the checker filter toward the front.**

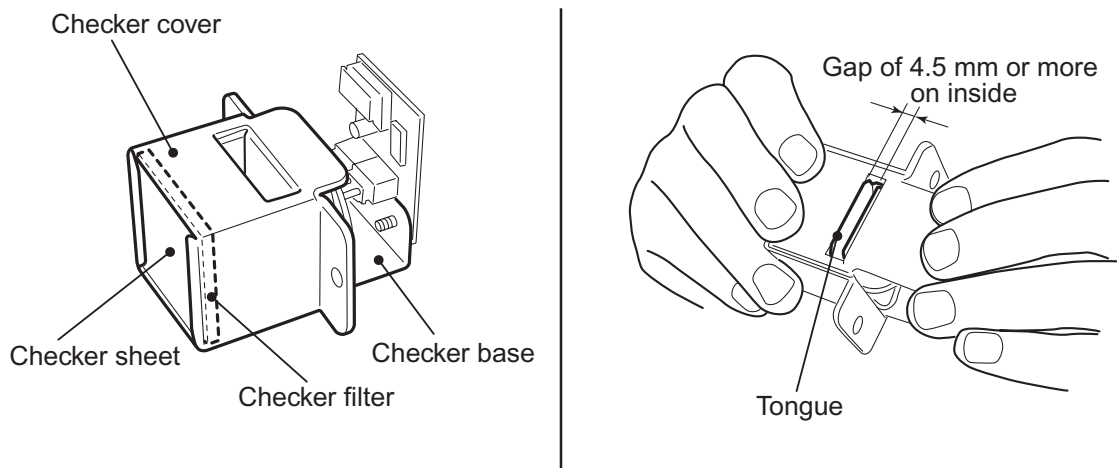

5. After re-assembly, conduct a checker output test. (see Motor Test page 61)

7-4-4 Replacing the LED PC Board

- **Pc Boards can be easily damaged by static electricity. If a person charged with static electricity handles a PCB, electronic components on the board can be damaged.**
Before handling a PCB, touch an earthed metal surface to release the electrostatic charge from the body.
1. Remove the Checker Cover. (see 7-4-3 page 111)
 2. Disconnect the connector, remove 1 off pozi head screw (M3x6), and remove the LED PC Board.
 3. Re-assemble in reverse order.
- **When replacing the LED PC Board, keep the prism installed in each checker sensor in a safe place to prevent it being lost, and be sure to re-install it.**

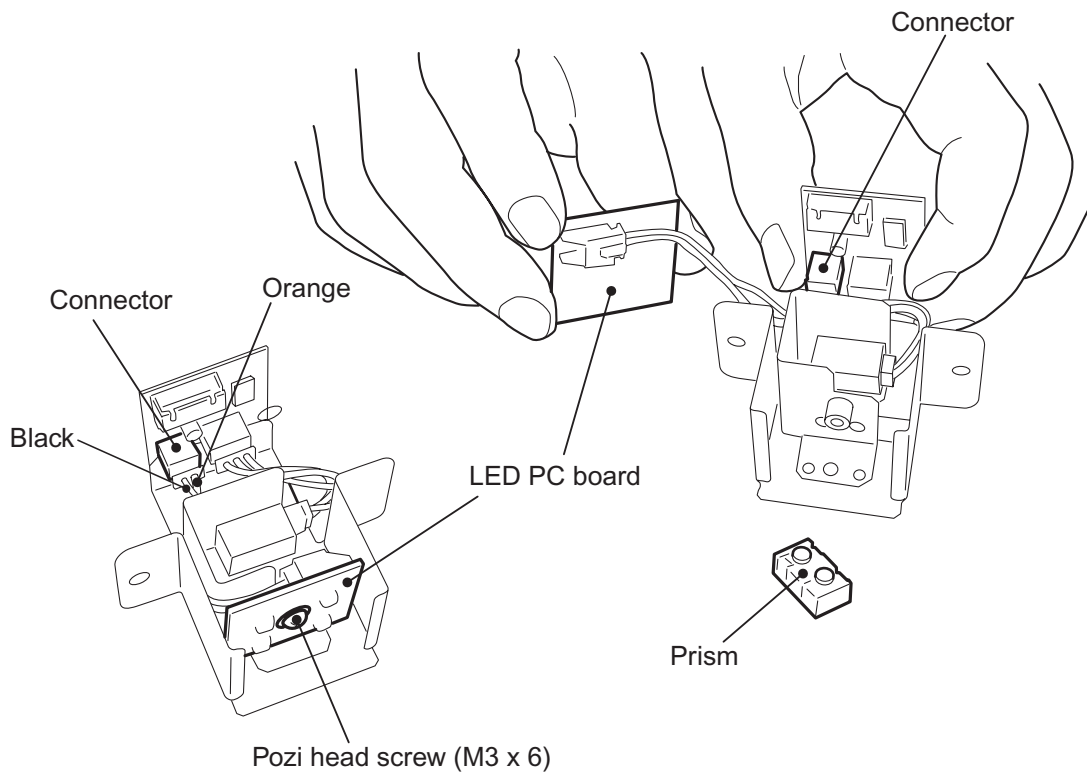

7-4-5 Replacing the Wiper Motor

- **Do not turn the Wiper Motor by hand. Doing so can damage the internal gears.**
- 1 Remove the maintenance panel from the rear of the cabinet.
 - 2 Disconnect the connector, remove 4 off snap pins and 8 off flat washers (M5).
 - 3 Remove 4 off whizz nuts (M4), and remove the Wiper Motor with Bracket.

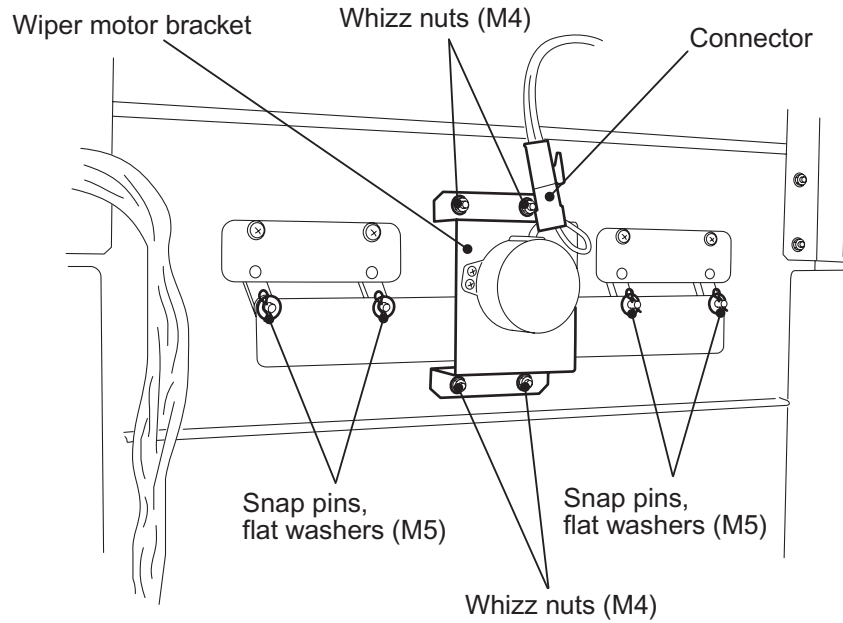

4. Remove 1 off snap pin, 2 off flat washers (M6), and remove the Wiper Link Plate.

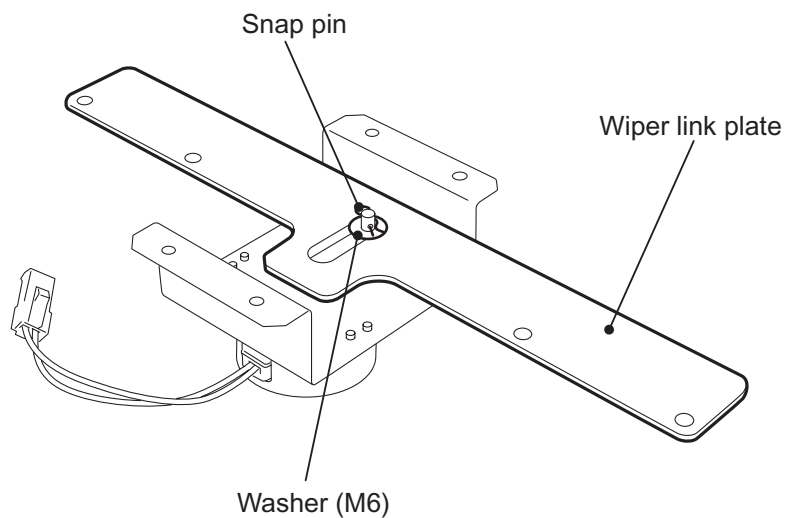

5. Loosen the double point screw (M4x5), and remove the Wiper Motor Crank.

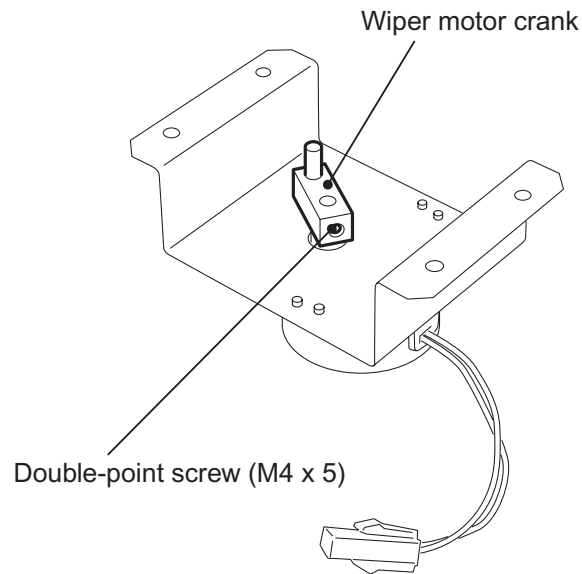

6. Remove the 4 off pozi head screws(M3x6), with spring washers, and remove the Wiper Motor.
 7. Re-assemble in reverse order.
- **When re-assembling, make sure that the gap between the wiper motor crank and the motor is 1mm before tightening the double point screw.**
 - **Make sure that the double point screw is in contact with the flat on the motor shaft, and apply loctite to the threads before tightening.**

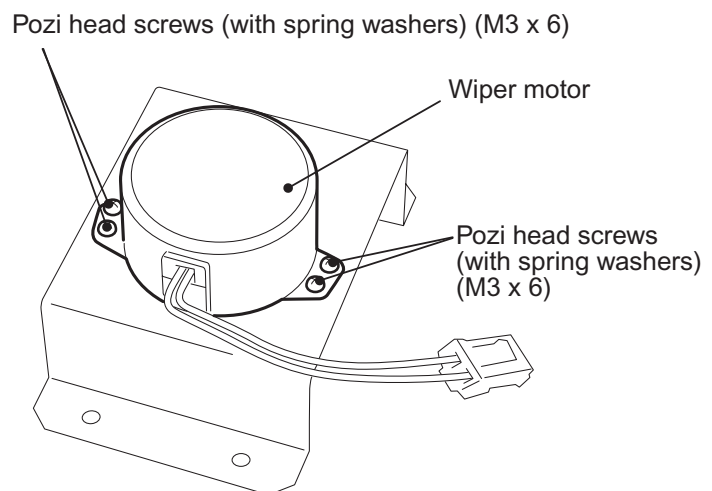
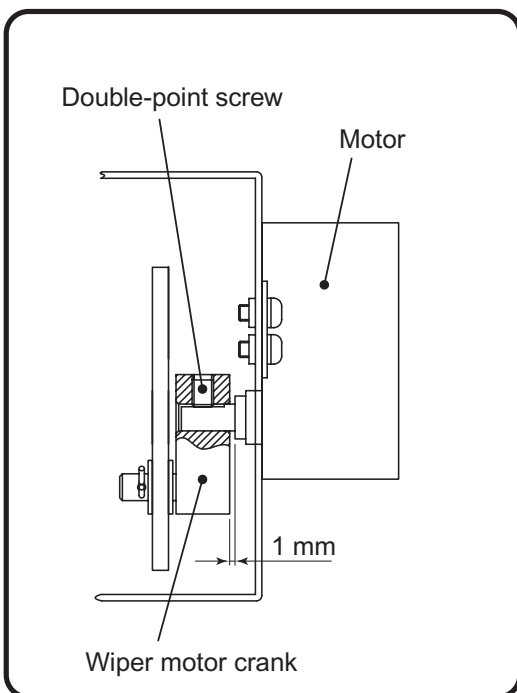

7-4-6 Replacing the LED Assembly

1. Remove the maintenance panel from the rear of the cabinet.
2. Disconnect the connector, remove 4 off flanged hex nuts (M3), and remove the LCD Assembly.
Take care not to lose the duracon spacers.

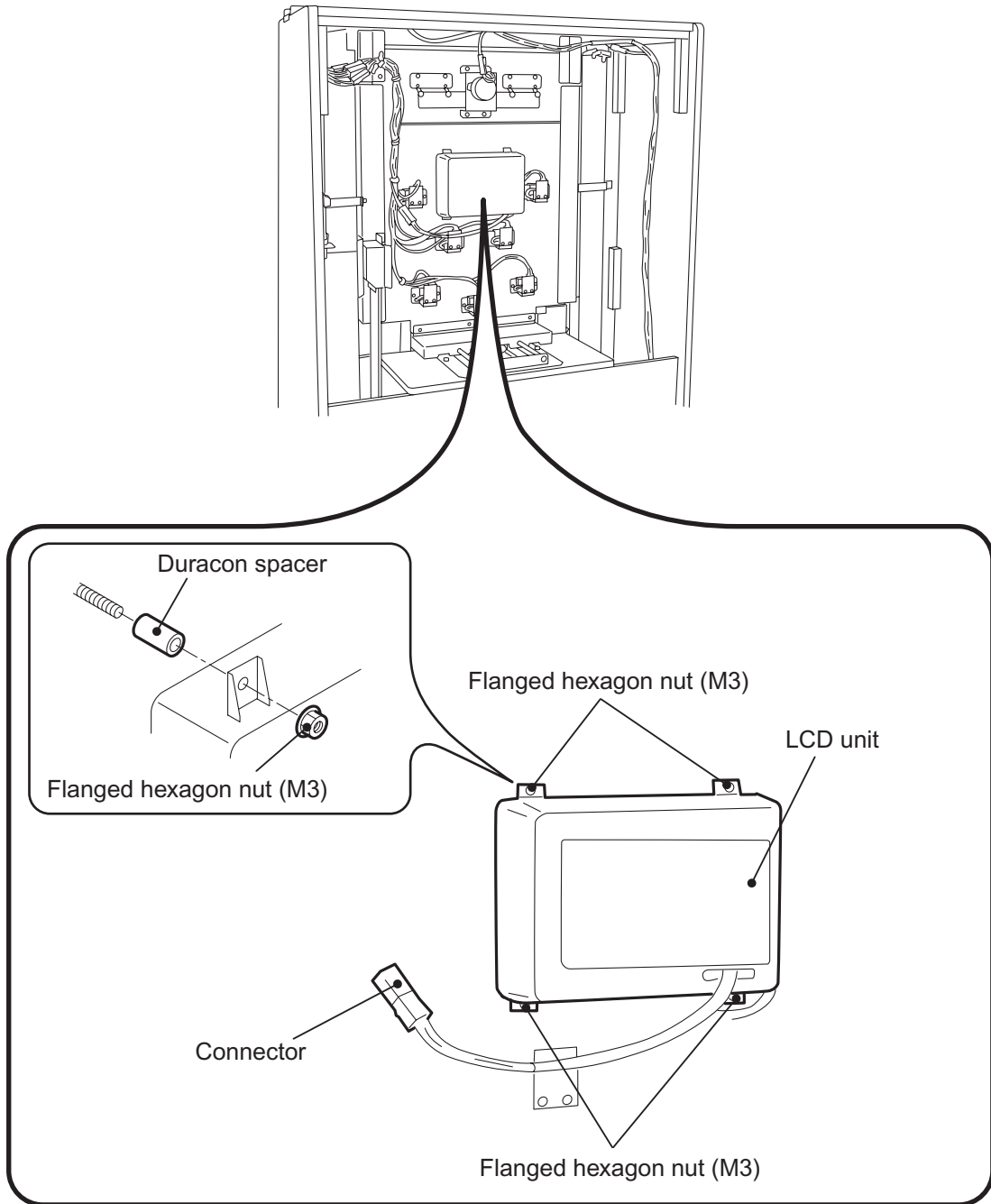

3. Re-assemble in reverse order.

7-5 Payout Assembly

1. Switch the power to the machine OFF.
2. Remove the maintenance panel from the rear of the cabinet.
3. Remove 4 off button head screws (M6x20), 2 off button head screws (M4x6), with flat washers, and remove the Front Cover.

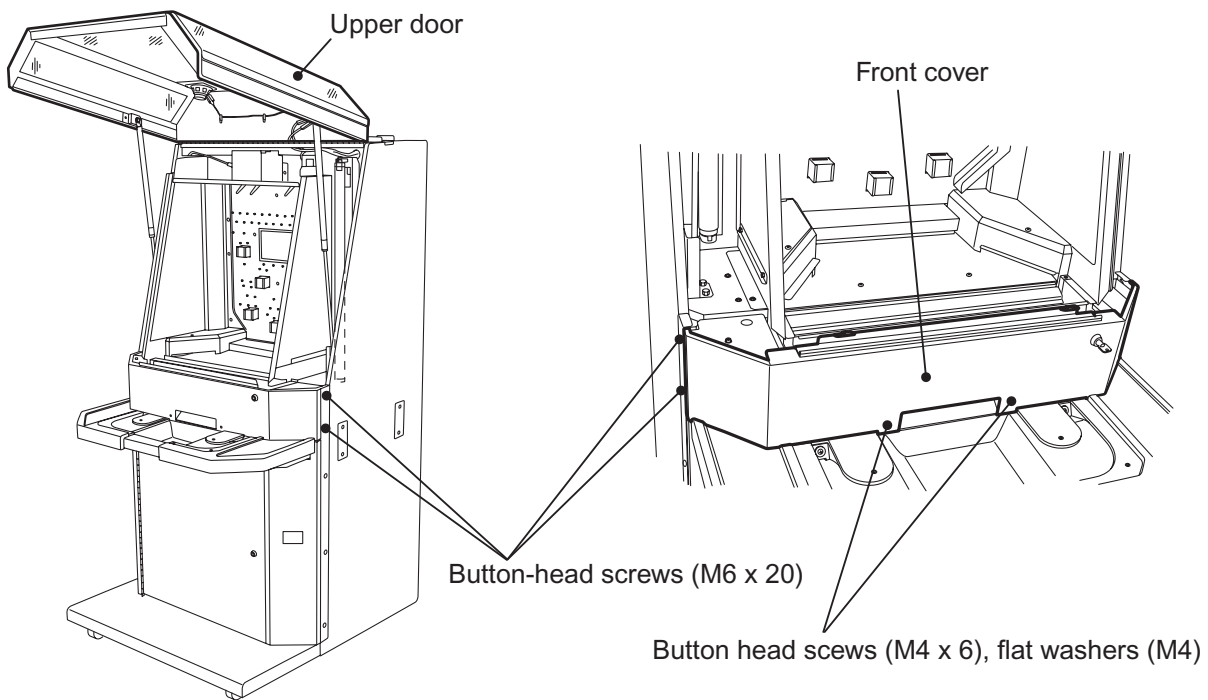

4. Disconnect the connector, and remove 4 off pozi head screws (M3x6).
 5. Remove 2 off snap pins and 2 off flat washers (M5), and detach the spring.
 6. Loosen the double point screws (M4x5), and pull out the block.
 7. Remove 1 off spring pin (4x16), remove the solenoid plate, and replace the Solenoid.
 8. Re-assemble in reverse order.
- **Make sure that one of the double point screws is engaged on the flat of the Divider (shaft section), and apply Loctite to the threads before tightening.**
 - **When re-assembling, make sure that the Divider (shaft section) end is flush with the Block end face.**
 - **When re-installing, install the Spring Pin so that the gap section is located at the top.**

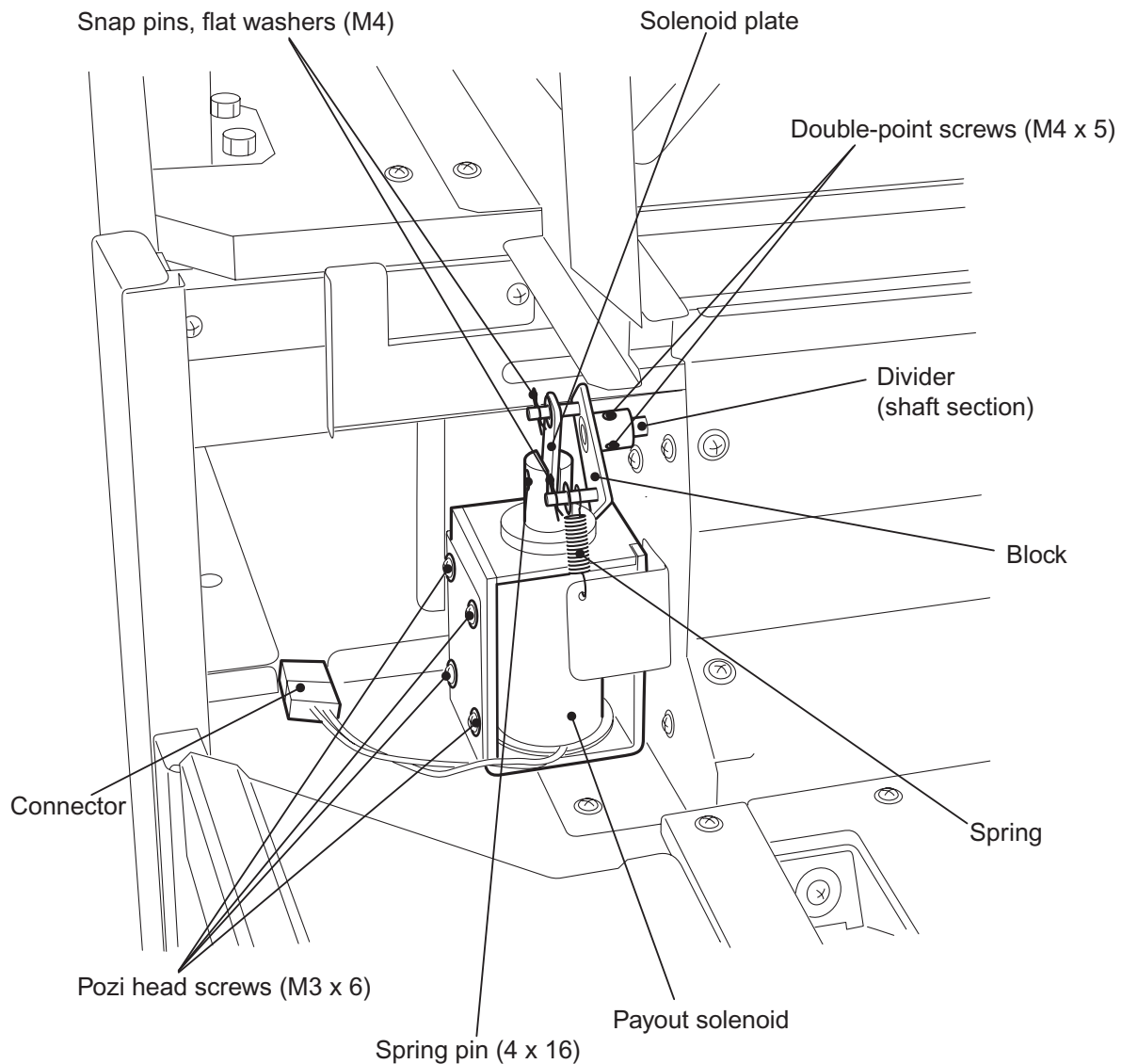

7-6 Replacing the Arm rests

1. Remove 4 off Torx screws (M5x12).
2. Unlock and open the Front Door, and remove the under panel by sliding it towards the back.

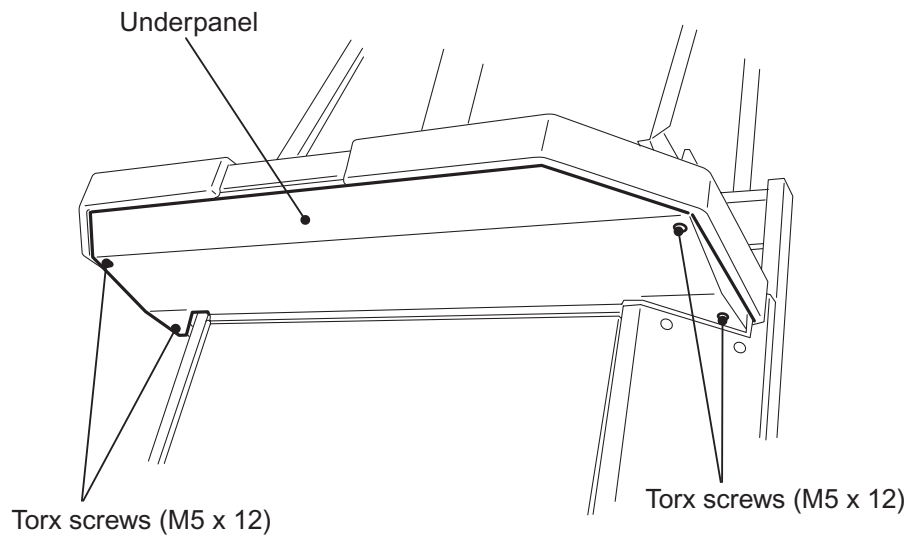

3. Remove 8 off whizz nuts (M4), and remove the Armrests (L), (R).

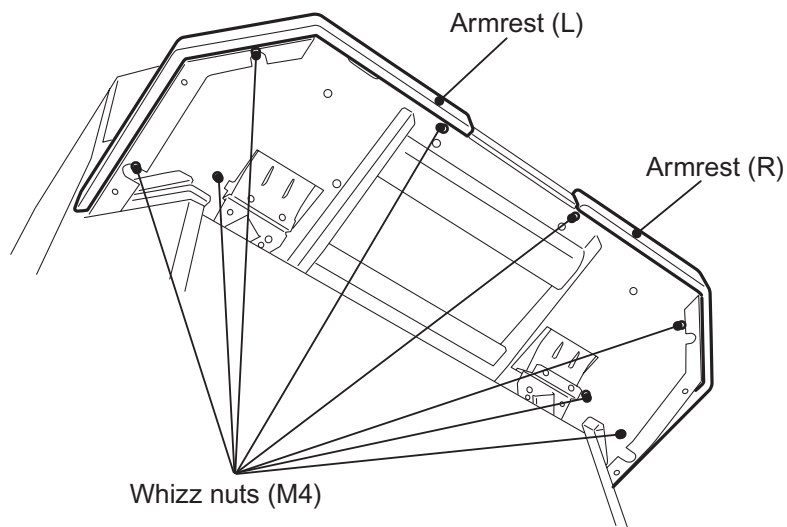

4. Re-assemble in reverse order.

7-7 Coin Selector (L), (R) Assemblies

7-7-1 Removing the Coin Selector (L), (R) Assys

The following describes the procedures for removing and re-installing the Coin Selector (R) Assy. Follow the same procedures for the removal of Coin Selector (L).

1. Remove the Underpanel. ([see 7-6 page 118](#))
 2. Disconnect the connector and Earth connector, remove 2 off pozi head screws (M4x6), and remove the Coin Selector (R) Assy.
 3. Re-assemble in reverse order.
- **When re-assembling, ensure that the harness near the connector does not block the coin passage or contact the inside of the Coin Divider (L), (R) Assy.**

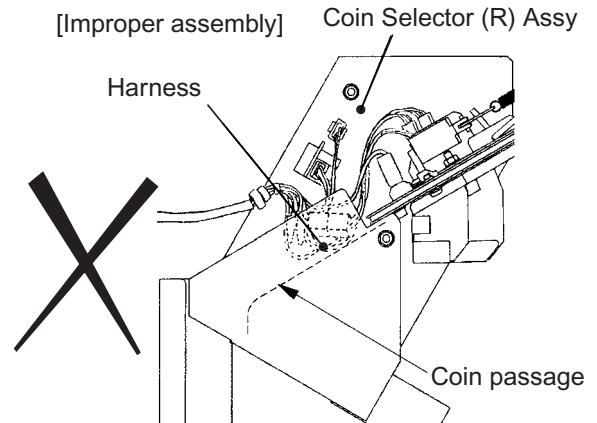
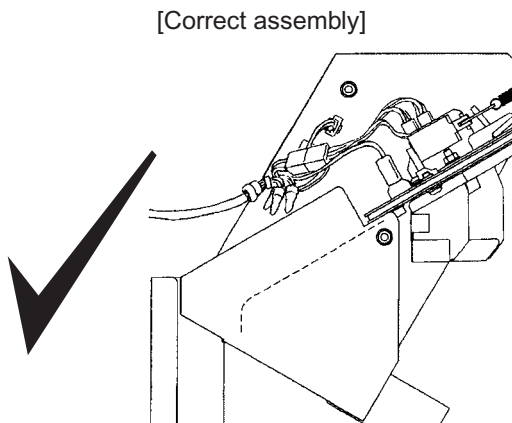
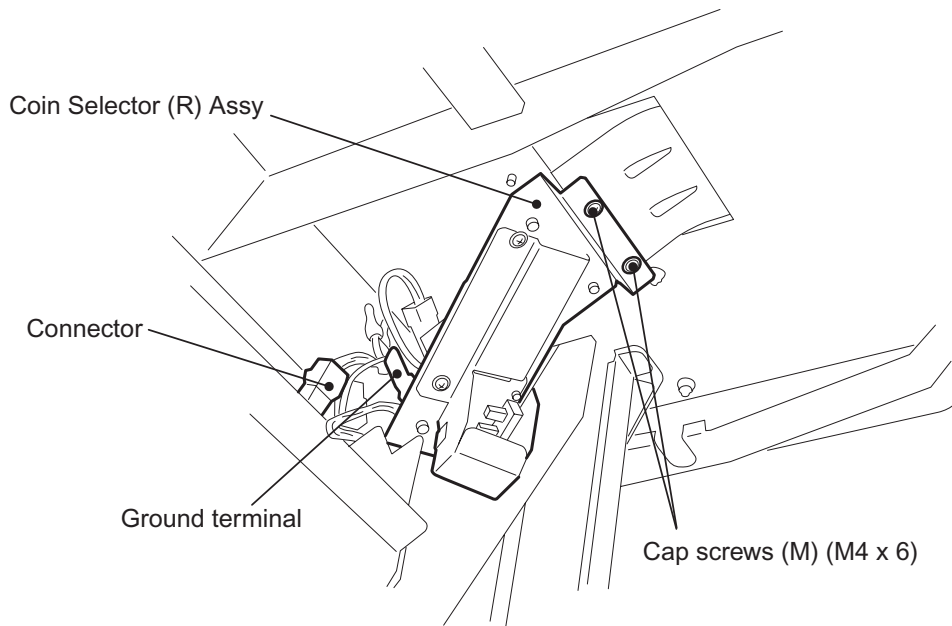

7-7-2 Replacing the Coin Sensors

The following describes the procedures for removing and re-installing the Coin Selector (R) Assy. Follow the same procedures for the removal of Coin Selector (L).

1. Remove the Coin Selector (R) Assy. ([see 7-7-1 page 119](#))
2. Disconnect the two connectors, remove 2 off pozi head screws (M4x14), and remove the twin-sensor holder.
 - *The coin sensor connectors are colour-coded in red and white. When re-assembling, ensure that the connectors are matched colour to colour.*

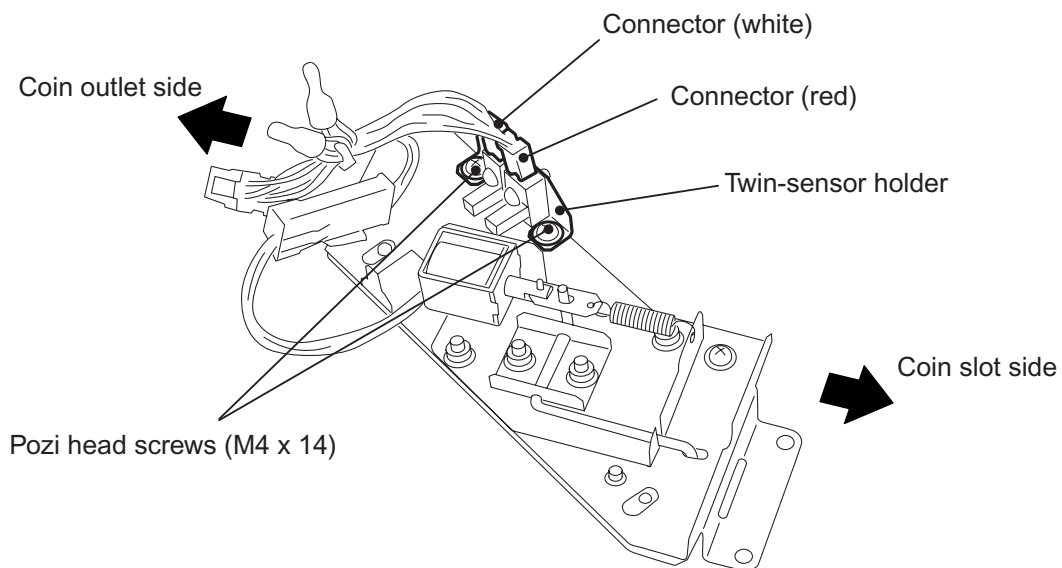

3. Remove 2 off phillips pan head screws (M4x14) and replace the Coin Sensors.

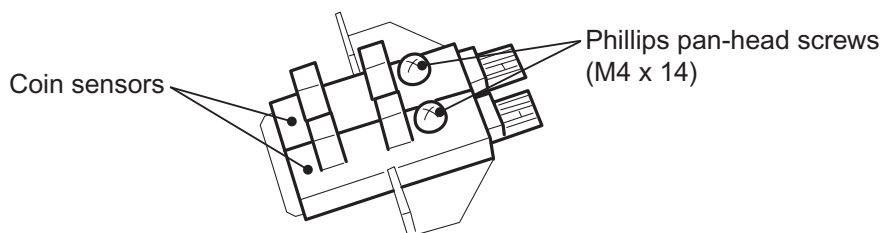

4. Re-assemble in reverse order.

7-7-3 Replacing the Lock-Out Solenoids

The following describes the procedures for removing and re-installing the Coin Selector (R) Assy. Follow the same procedures for the removal of Coin Selector (L).

1. Remove the Coin Selector (R) Assy. (see 7-7-1 page 119)
2. Disconnect the connector.
3. Remove the Twin-Sensor Holder. (see 7-7-2 page 120)

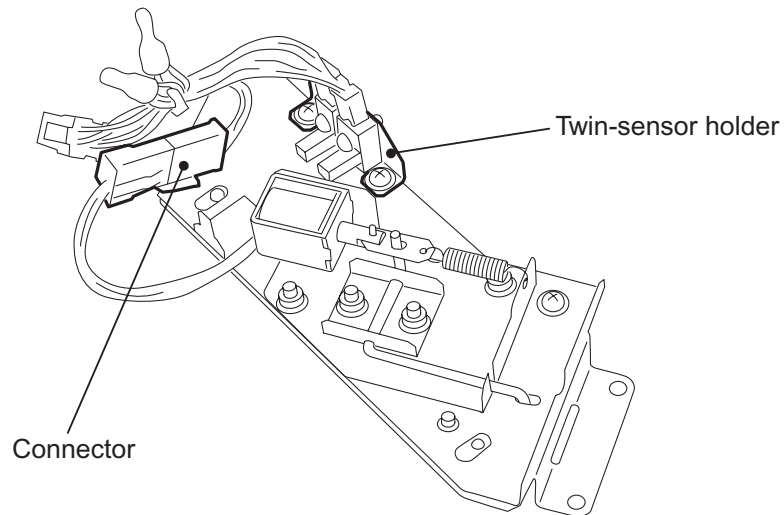

4. Remove 2 off pozi head screws (M3x4) and remove the Lock-Out Solenoid.
5. Remove 1 off Spring Pin (2x10), and remove the Plunger.
6. Replace the Solenoid.

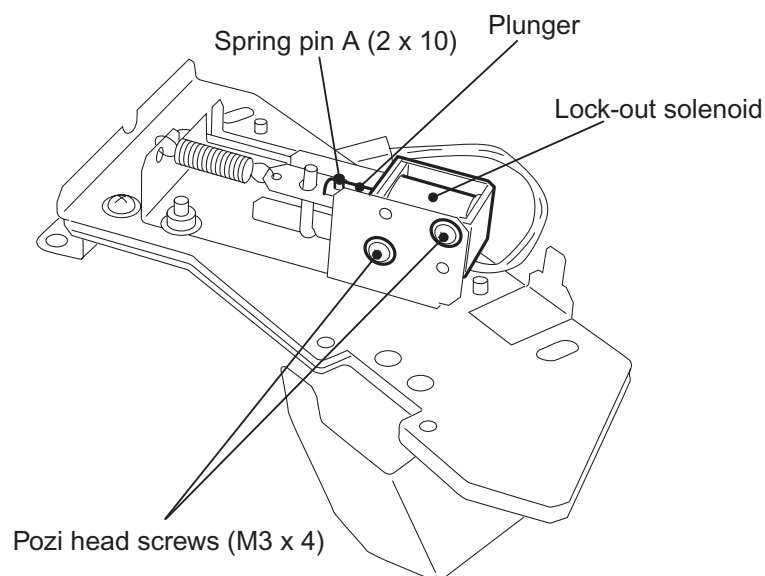

7. Re-assemble in reverse order.

7-7-4 Coin Divider (L), (R) Assys

7-7-4-1 Removing the Coin Divider (L), (R) Assys

The following describes the procedures for removing and re-installing the Coin Selector (R) Assy. Follow the same procedures for the removal of Coin Selector (L).

1. Remove the Coin Selector (R) Assy. ([see 7-7-1 page 119](#))
2. Disconnect the connector, remove 2 off Whizz nuts (M4), and remove the Coin Divider (R) Assy.

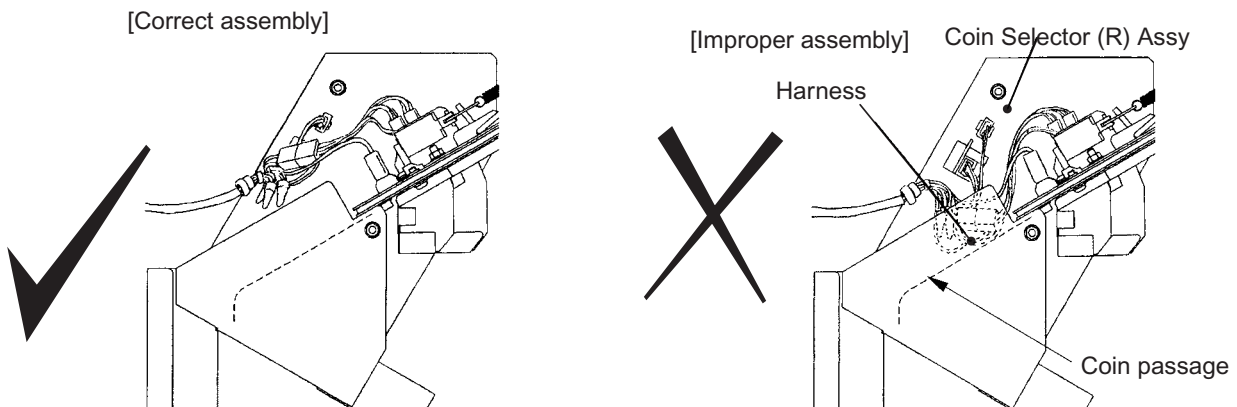
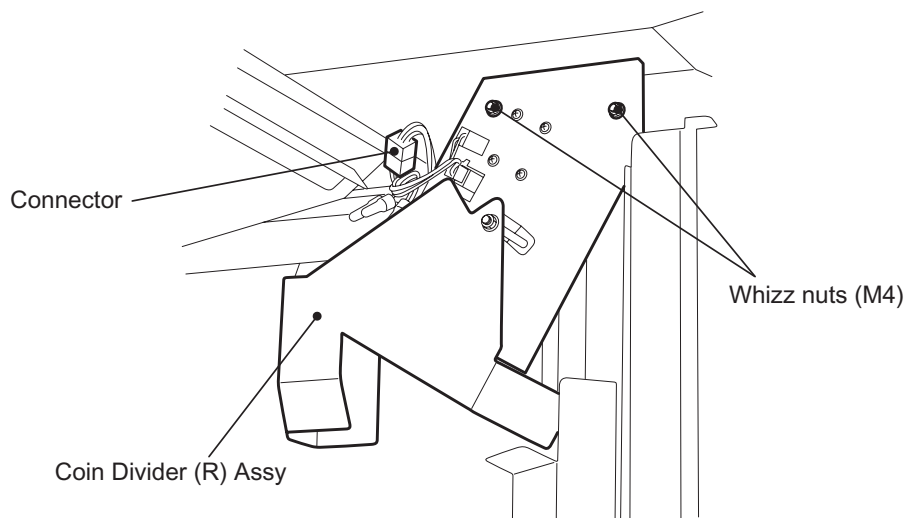

3. Re-assemble in reverse order.
 - **When re-assembling, ensure that the harness near the connector does not block the coin passage or contact the inside of the Coin Divider (L), (R) Assy.**

7-7-4-2 Replacing the Divider Solenoid Sensors

The following describes the procedures for removing and re-installing the Coin Selector (R) Assy. Follow the same procedures for the removal of Coin Selector (L).

1. Remove the Coin Selector (R) Assy. (see 7-7-1 page 119)
2. Disconnect the connector, remove 1 off pozi head screw (M4x6), and remove the Sensor Holder (R).

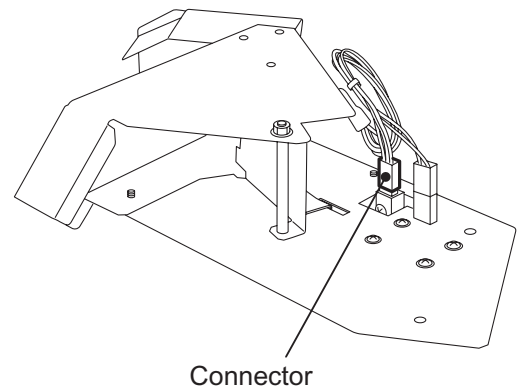
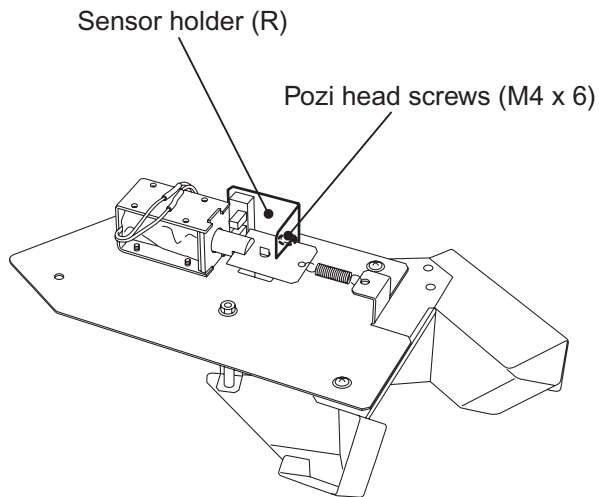

3. Remove 1 off Phillips pan-head screw (M4x14), and replace the Solenoid Sensor (R).

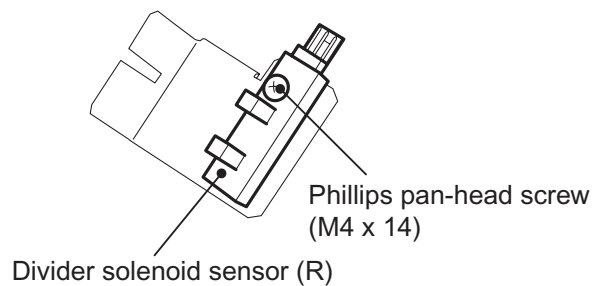

4. Re-assemble in reverse order.

7-7-4-3 Replacing the Divider Solenoids

The following describes the procedures for removing and re-installing the Coin Selector (R) Assy. Follow the same procedures for the removal of Coin Selector (L).

1. Remove the Coin Selector (R) Assy. (see 7-7-1 page 119)
2. Disconnect the connector, remove 1 off pozi head screw (M4x6) and remove the Sensor Holder (R).
3. Remove the spring.

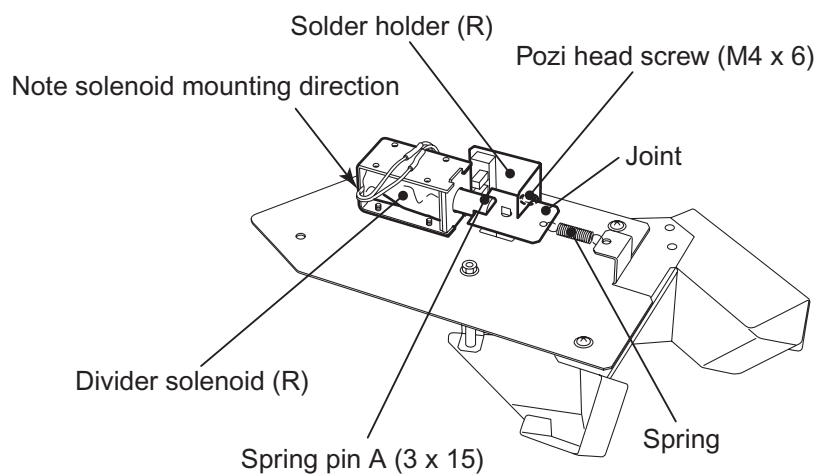
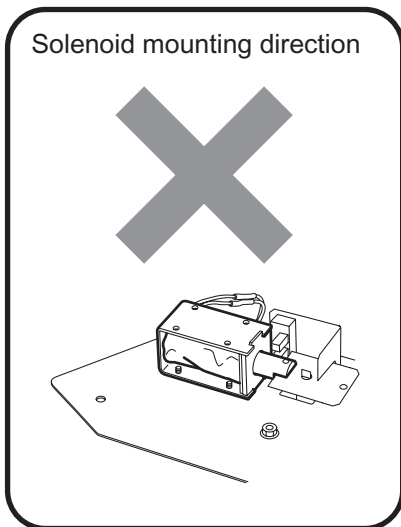

4. Disconnect the connector remove 4 off pozi head screws (M3x6).

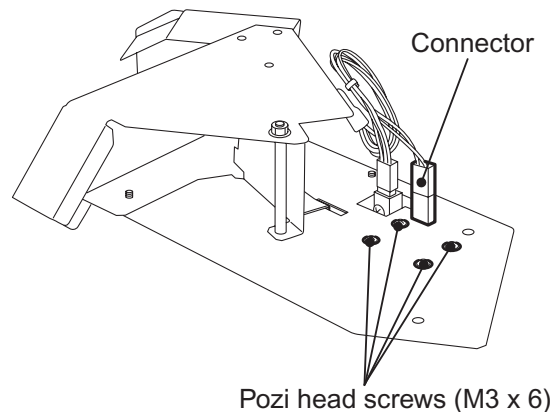

5. Remove 1 off Spring Pin (3x1.5), disengage the joint, and replace the Divider Solenoid (R).
 6. Re-assemble in reverse order.
- **When re-assembling, take note of the direction of the Solenoid Harness.**

7-8 Coin Hoppers

- The Coin Hoppers (L), (R) discharge coins onto the playfield in an amount equal to the number of coins inserted by the player. Therefore, the coin hoppers operate more frequently than those in other coin games, thus requiring periodic maintenance. Be sure to conduct the following maintenance.
- The coin hoppers can discharge approximately two million coins before they require replacement.
At an ejection rate of about 5,000 coins per day, the hopper service life is about one year.

7-8-1 Replacing the Coin Hoppers (L), (R)

1. Switch the power to the game OFF.
2. Unlock and open the front maintenance door.
3. Disconnect one 4pin connector, and one 3pin connector.
Do not remove the 2pin connector.

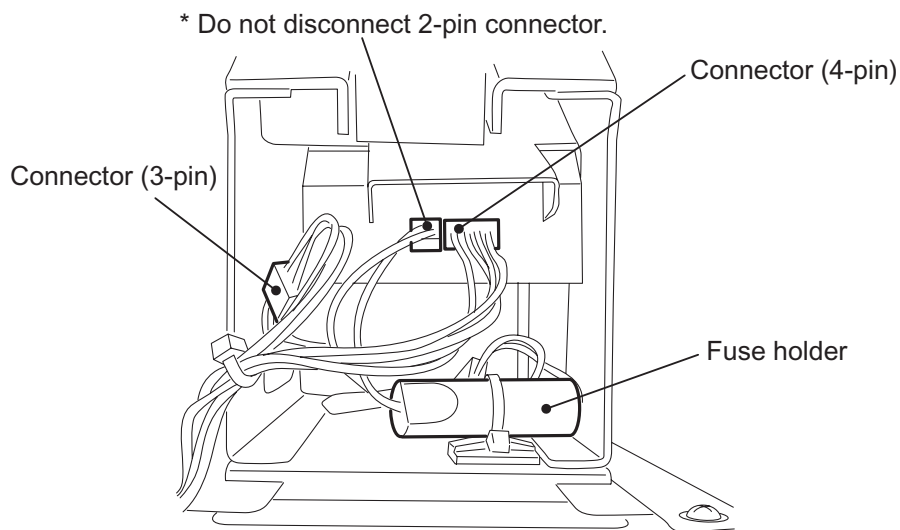

4. Remove the 2 off wing bolts (M4x12), and remove the escalator and hopper sections.

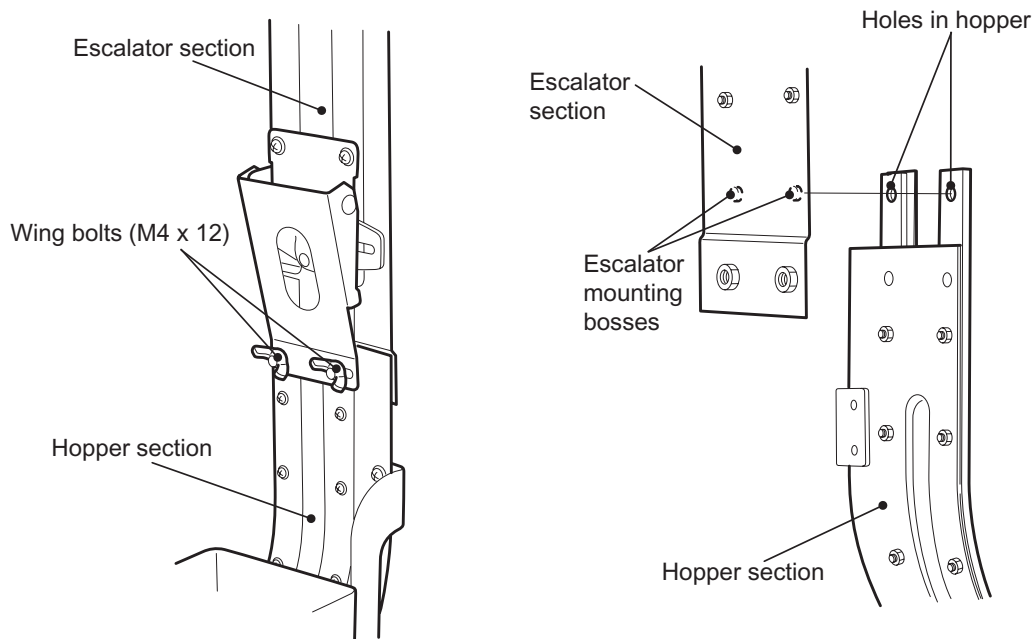

5. Remove 2 off pozi head screws (M4x20), and remove the Hopper.

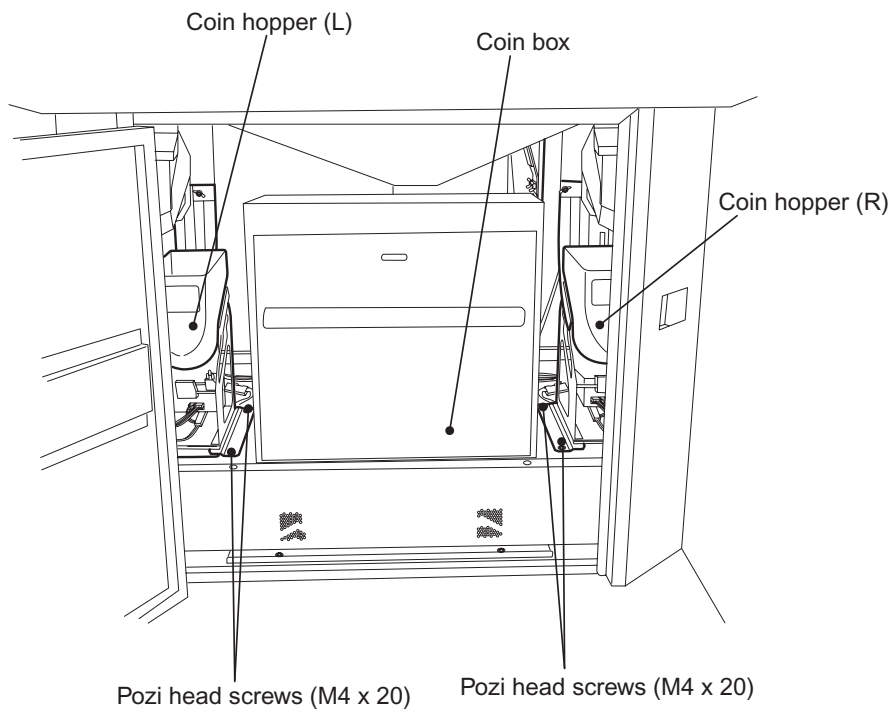

6. Re-assemble in reverse order.
 - **When re-assembling, align the escalator mounting bosses with the holes in the hopper, and secure the hopper with the wing bolts (M4x12). If the bolts are loose, coins can jam.**
 - **If the fuse is blown, contact your distributor.**

7-8-2 Removing the Escalators

1. Switch the power to the machine OFF.
2. Open the maintenance panel on the rear of the machine.
3. Remove the Escalator Section and Hopper Section. (see 7-8-1 page 125)
4. Remove 1 off flange socket head screw (M4x10) which is holding the Chute Hopper B in place.
5. Remove the flange socket head screw (M4x10) which is holding the Upper Escalator Section in place.
 - *In this step, be sure to hold the escalator to prevent it from falling.*

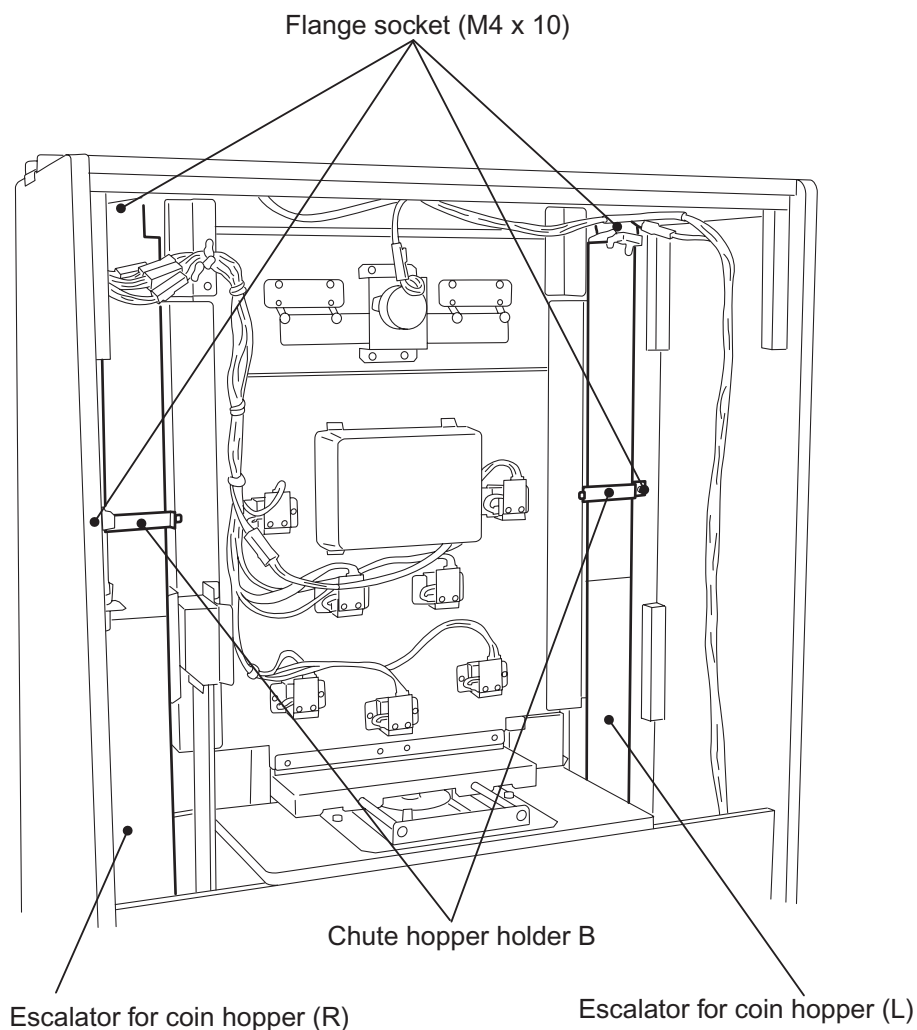

6. Re-assemble in reverse order.

7-8-3 Removing Coin Hopper C

1. Switch the power to the machine OFF.
2. Open the maintenance panel on the rear of the machine.
3. Remove the Hopper Head A.
4. Disconnect one 4pin connector, and one 3pin connector.
Do not remove the 2pin connector.

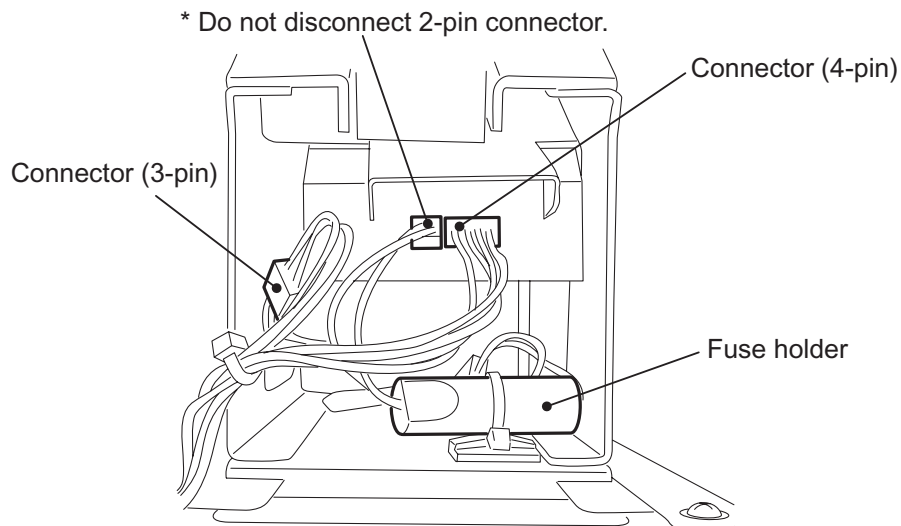

5. Remove the 2off wing bolts (M4x12), and remove the escalator and hopper sections.

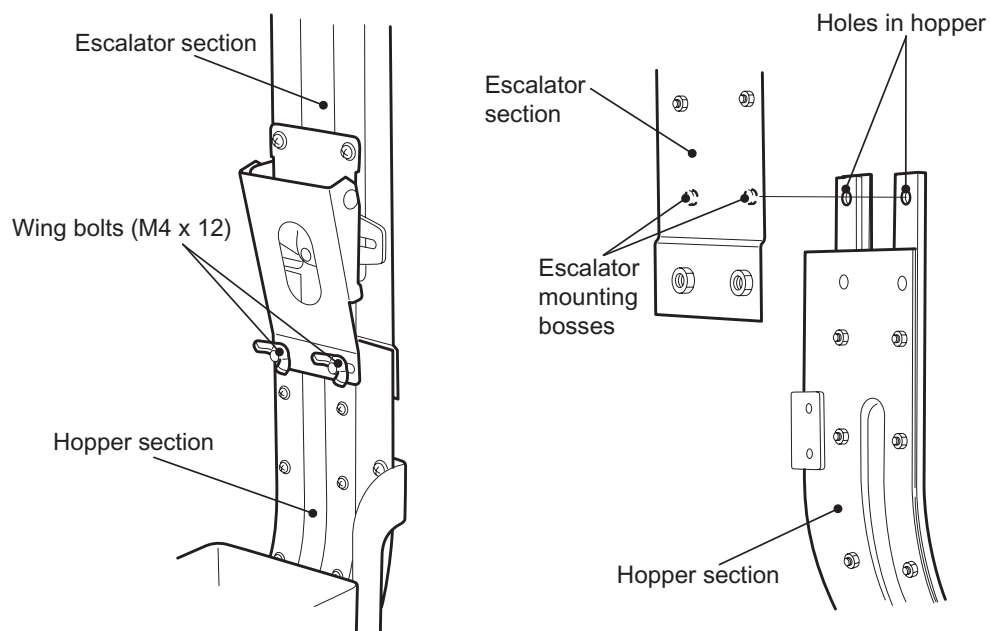

- Remove 2 off pozi head screws (M4x20), and remove the Coin Hopper C.

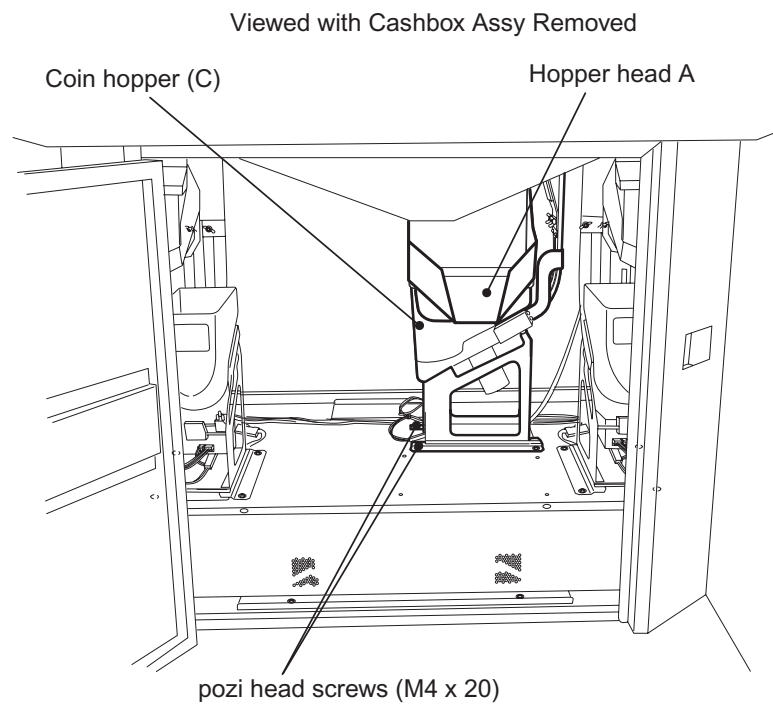

- Remove 2 off pozi head screws (M4x6), remove the Disc Guard and replace the Coin Hopper C.

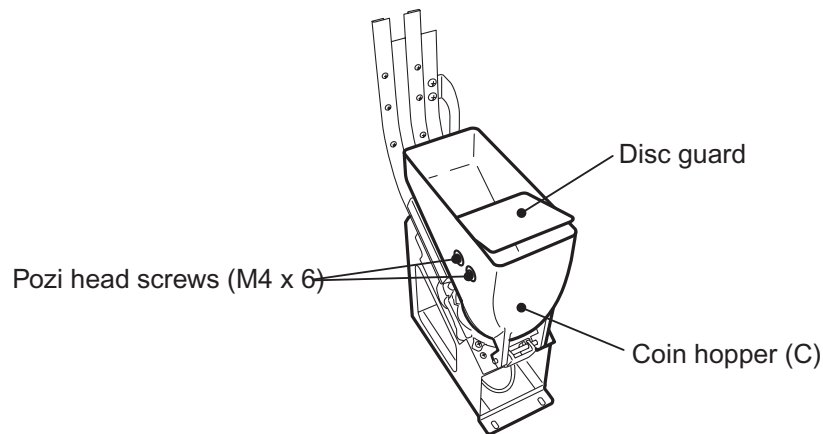

- Re-assemble in reverse order.
 - When re-assembling, align the escalator mounting bosses with the holes in the hopper, and secure the hopper with the wing bolts (M4x12). If the bolts are loose, coins can jam.**
 - If the fuse is blown, contact your distributor.**

7-8-4 Removing Hopper C Escalator

1. Switch the power to the machine OFF.
2. Open the maintenance panel on the rear of the machine.
3. Remove the Escalator Section and Hopper Section. ([see 7-8-3 page 128](#))
4. Remove 1 off pozi head screw (M4x6) and remove the Escalator.
 - *In this step, be sure to hold the escalator to prevent it from falling.*

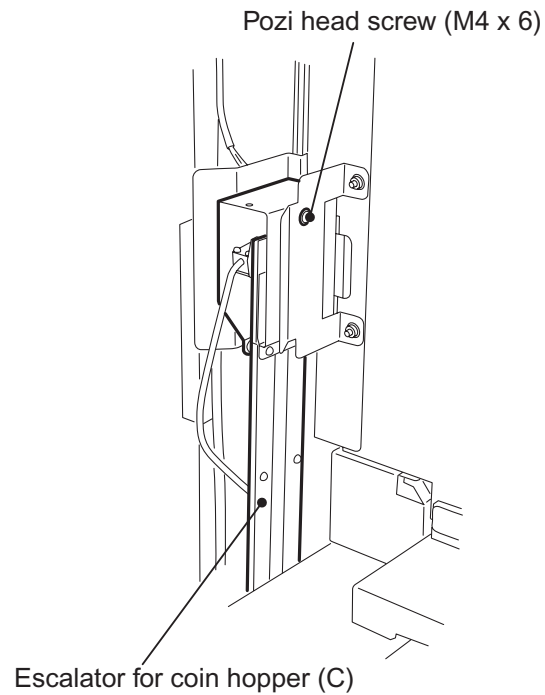

5. Re-assemble in reverse order.

7-8-5 Replacing the Polysliders

1. Switch the power to the machine OFF.
2. Open the maintenance panel on the rear of the machine.
3. Remove the coins from the coin hopper for the Polysliders to be replaced.
(see 6-2-6 page 81)
4. Remove the Coin Hopper and Escalator.
(see 7-8-1 page 125 and 7-8-3 page 128)
5. Remove 1off E-ring, 1off spring, and replace the Polysliders.

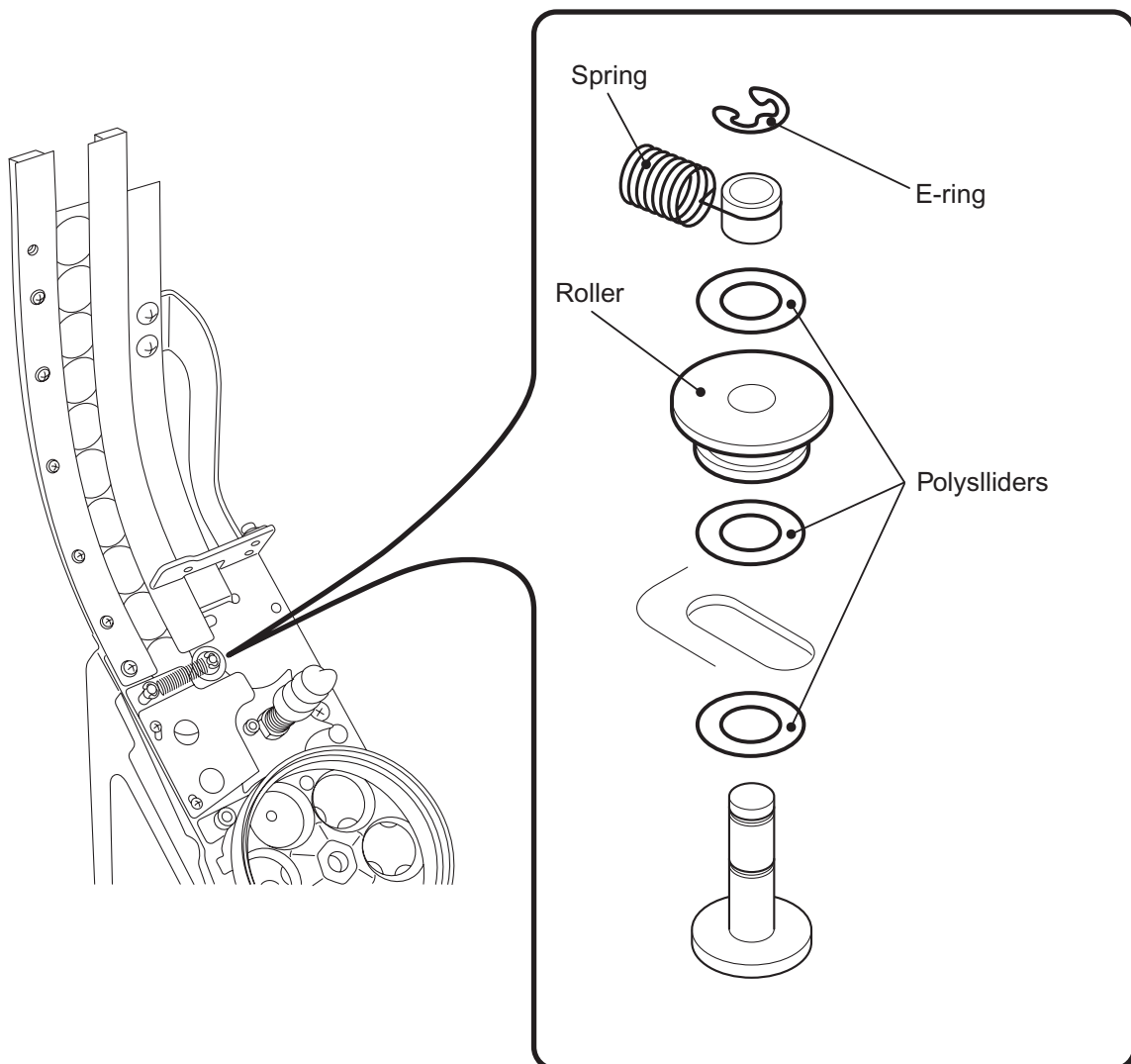

6. Re-assemble in reverse order.
- **If the roller on the slide section does not rotate smoothly, replace the polysliders.**
 - **Install a new E-ring when polysliders are replaced.**

8. PARTS

8-1 Cabinet

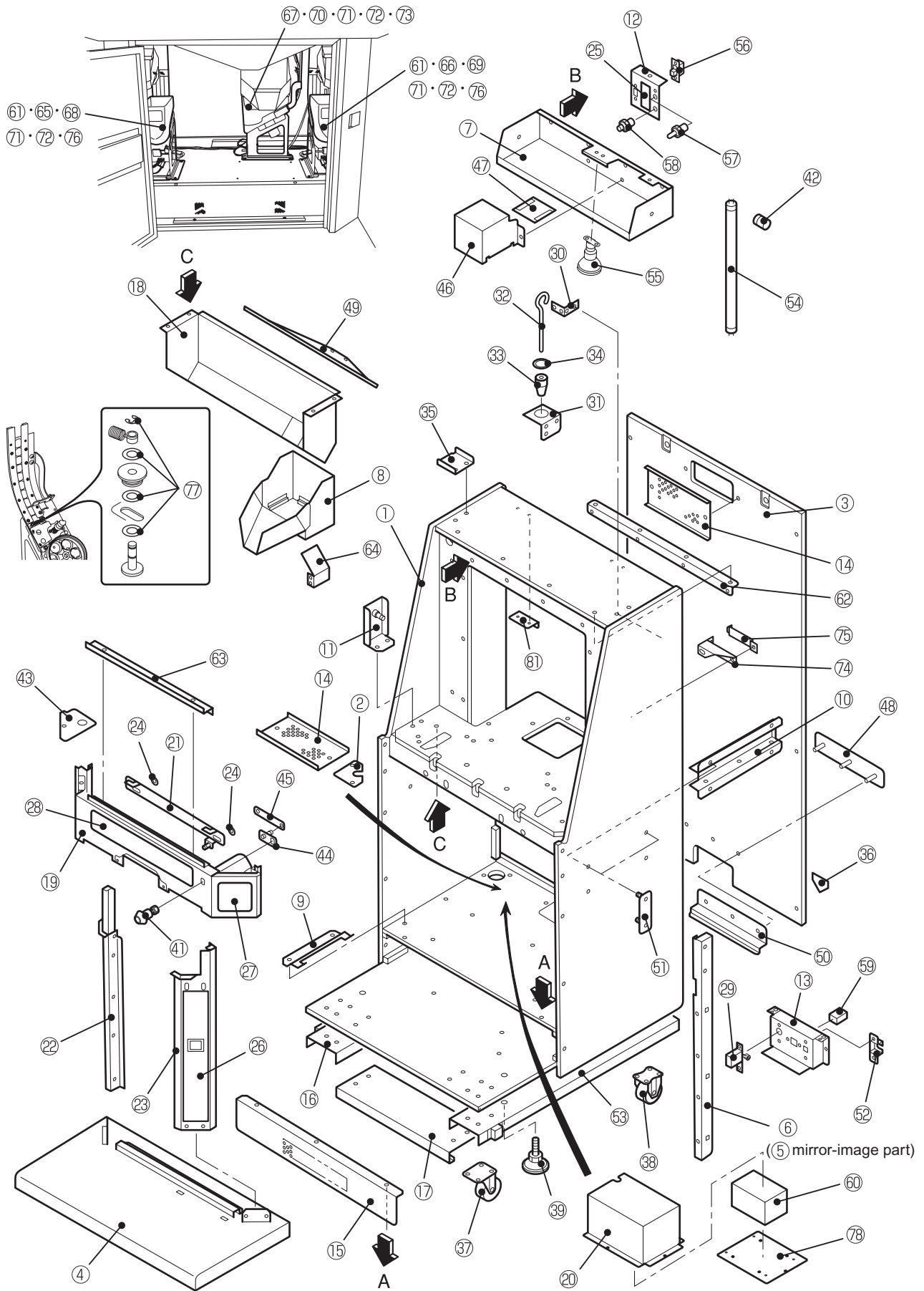

Item	Description	Part No
1	Main Cabinet	XPMB-707-920
2	Harness Cover	XPMB-705-442
3	Rear Panel	XPMB-707-922
4	Foot Rest Cover	XPMB-707-923
5	Side Frame L	XPMB-705-413
6	Side Frame R	XPMB-705-414
7	Halogen Lamp Cover A	XPMB-705-415
8	Hopper Head A	XPMB-705-416
9	Hopper Guide B	XPMB-705-417
10	Armrest Base	XPMB-705-418
11	Gas-Cylinder Spring Base	XPMB-705-419
12	Service Plate	XPMB-705-420
13	Cord Box	XPMB-705-421
14	Dust Cover	XPMB-705-422
15	PC Board Cover	XPMB-705-423
16	Castor Base L	XPMB-705-424
17	Castor Base B	XPMB-705-425
18	Coin Chute	XPMB-705-426
19	Front Cover	XPMB-705-427
20	Transformer Cover	XPMB-707-927
21	Slide Lock	XPMB-705-429
22	Maintenance Door Pillar L	XPMB-705-430
23	Maintenance Door Pillar R	XPMB-705-431
24	Detent Washer	XPMB-705-432
25	Service Decal	XPMB-707-931
26	Maintence Door Side Decal L, R (set)	XPMB-705-434
27	Front Cover Side Decal	XPMB-705-435
28	Instructions Decal	XPMB-707-932
29	Circuit Breaker - CP32PM/5	XPMB--000-424
30	Tilt Bracket (B)	XPMB-695-702
31	Tilt Bracket (B)	XPMB-695-703
32	Pendulum	XPMB-695-705
33	Weight	XPMB-695-705
34	Switch Ring	XPMB-695-707
35	Rope Hook (E)	XPMB-450-142
36	'Fork Here' Decal	XPMB-229-441
37	Swivel Castor STC-75NM	XPMB-102-199
38	Fixed Castor SKC-75NM	XPMB-102-201

Item	Description	Part No
39	Level Adjuster LD-102	XPMB-102-222
41	Lock SP-81-MS-1 W/2	XPMB-101-016
42	Starter	XPMB-002-107
43	Left Side Cover	XPMB-705-437
44	Key Lock Plate	XPMB-705-438
45	Key Side Plate	XPMB-705-439
46	Halogen Lamp Cover B	XPMB-705-440
47	Halogen Lamp Cover C	XPMB-705-441
48	Door Support Plate	XPMB-707-925
49	Coin Chute Cover	XPMB-705-443
50	Door Support Bracket	XPMB-705-924
51	Armrest Bolt Plate	XPMB-705-445
52	Modular Cover	XPMB-704-161
53	Castor Base R	XPMB-705-447
54	Fluorescent Lamp FL20SEX-KD 110V/20W	XPMB-002-304
55	Halogen Lamp JDR110V40WLN/K	XPMB-002-358
56	Miniature Slide Switch	60000023
57	SPDT Toggle Switch (momentary action)	60000010
58	Pushbutton Switch 7mm - Red	60000059
59	Main-In Filter FN9222-10-06	- - -
60	Transformer ST-11101 (300VA)	XPMB-004-589
61	Payout Sensor	XPMB-000-479
62	Upper Door Bracket	XPMB-707-926
63	Lock Base Bracket	XPMB-705-449
64	Disc Guard	XPMB-707-934
65	Coin Hopper (L) WH-2/U1 (2p) escalator 1380mm right discharge TDA-11695-A	XPMB-100-223
66	Coin Hopper (R) WH-2/U1 (2p) escalator 1380mm right discharge TDA-11696-A	XPMB-100-224
67	Coin Hopper (C) WH-2/U1 (2p) escalator 930mm right discharge TDA-11697-A	XPMB-100-225
68	Coin Hopper (L) WH-2/U1 (10p) escalator 1380mm right discharge TDA-11549-B	XPMB-100-226
69	Coin Hopper (R) WH-2/U1 (10p) escalator 1380mm right discharge TDA-11550-B	XPMB-100-227
70	Coin Hopper (C) WH-2/U1 (10p) escalator 930mm right discharge TDA-11551-B	XPMB-100-228
71	Coin Hopper WH-2/U1 (2p) without escalator TDA-11698-A	XPMB-100-233
72	Coin Hopper WH-2/U1 (10p) without escalator TDA-11557-A	XPMB-100-234
73	Payout Sensor	XPMB-000-479
74	Chute Hopper Holder (A)	XPMB-705-535
75	Chute Hopper Holder (B)	XPMB-705-536
76	Escalator Decal	XPMB-705-537
77	Polyslider Set (3 polysliders, 1 E-ring)	XPMB-100-221
78	Transformer Base	XPMB-707-930
81	Lock Bracket	XPMB-707-929

8-2 Front Door Assy

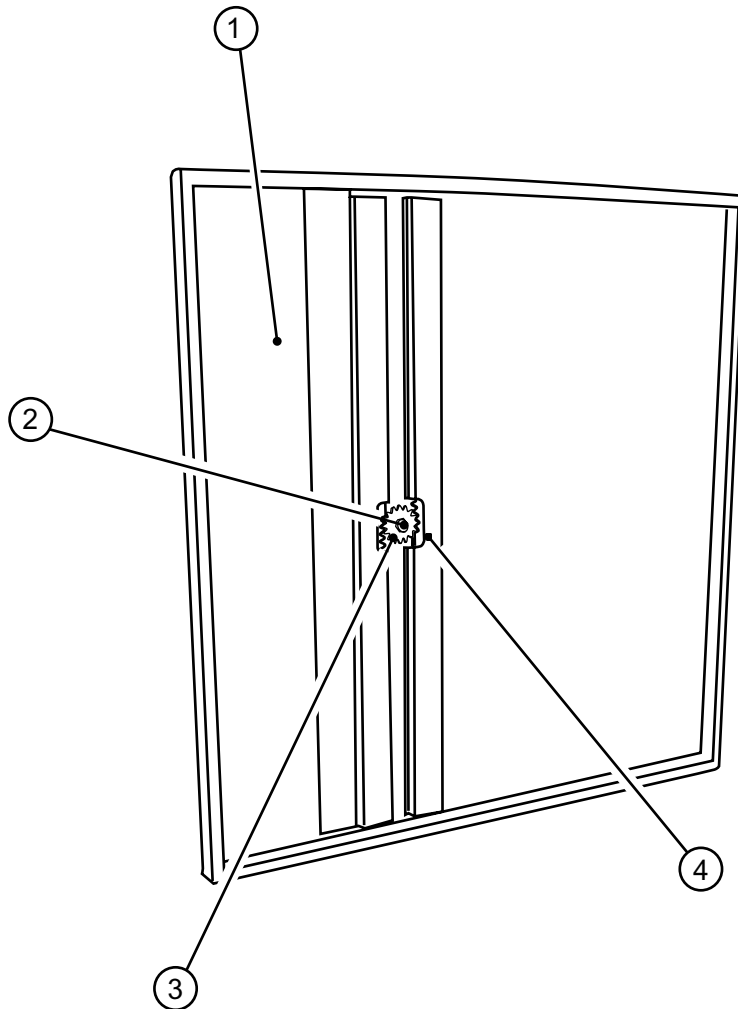

Item	Description	Part No
1	Front Door (complete)	47000723
2	1¼" Lock	24000081B
3	Door Locking Cog	47000734
4	Door Locking Bar	47000733

8-3 Playfield Door Assy

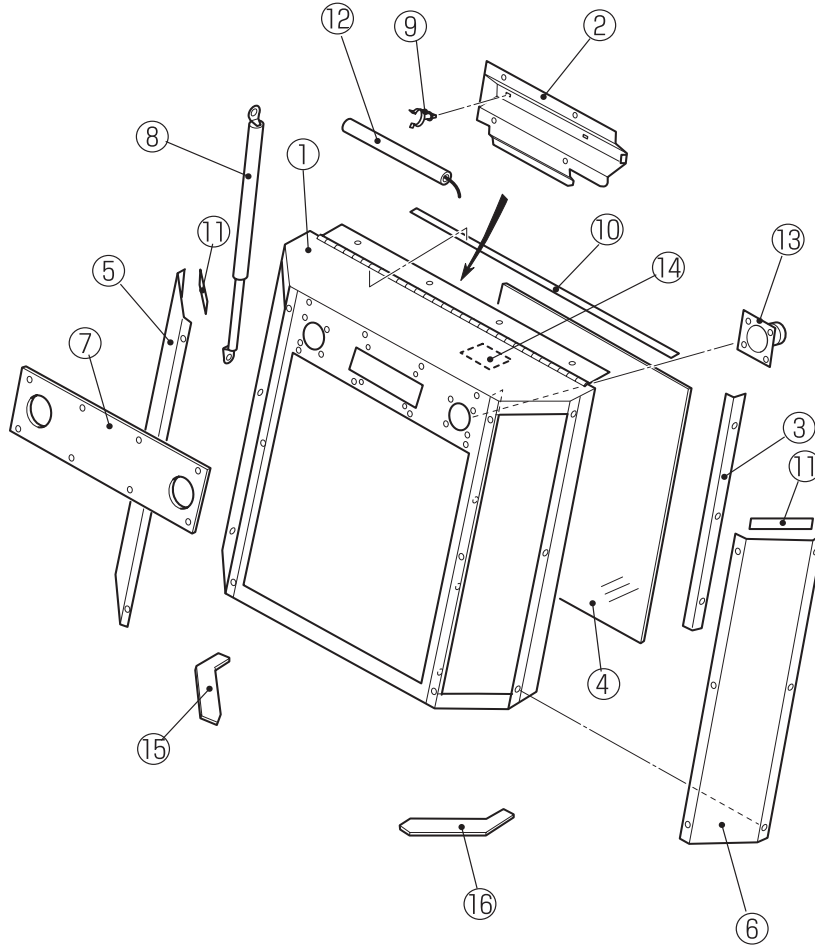

Item	Description	Part No
1	Upper Door Frame	XPMB-705-949
2	Lamp Cover	XPMB-705-461
3	Panel Support	XPMB-705-462
4	Upper Shield	XPMB-705-463
5	Door Side Panel L	XPMB-705-464
6	Door Side Panel R	XPMB-705-465
7	Title Panel	XPMB-705-466
8	Gas-Cylinder Spring G20K0	XPMB-105-144
9	Rod Holder A-1 05B1	XPMB-101-137
10	Upper Door Seal A	XPMB-705-467
11	Upper Door Seal B	XPMB-705-468
12	Win Lamp REIL-240-R-NMD4	XPMB-002-375
13	Speaker NF777A	XPMB-006-146
14	Hopper NOTICE Decal	XPMB-707-950
15	Upper Door Seal C (L)	XPMB-705-469
16	Upper Door Seal C (R)	XPMB-705-470

8-4 PC Board Base Assy

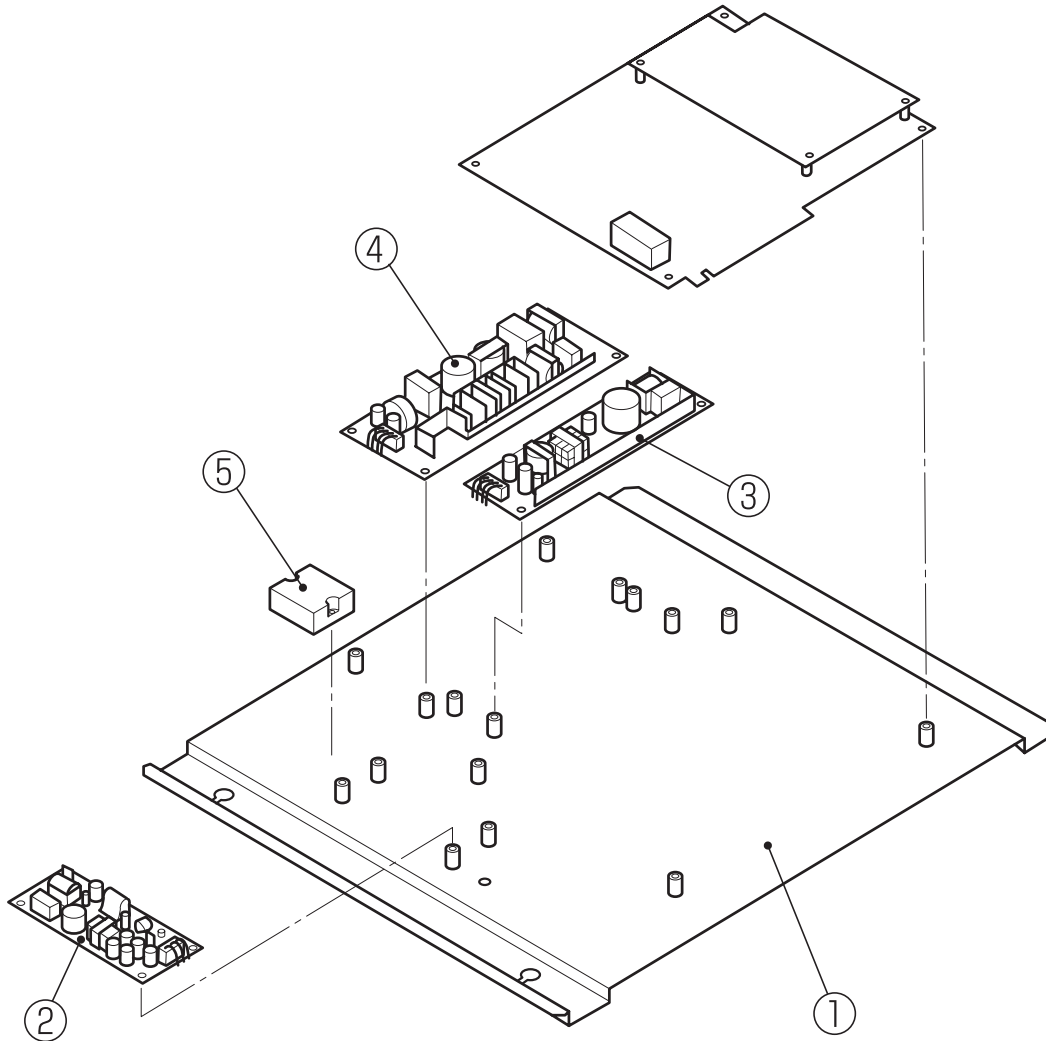

Item	Description	Part No
1	PC Board Base	XPMB-705-956
2	SMPSU (5V) VS30B-5	XPMB-009-088
3	SMPSU (12V) VS50B-12	XPMB-009-095
4	SMPSU (24V) ZWS150PAF-24/J	XPMB-009-160
5	SSR S5C-215L-V	XPMB-004-630

8-5 Armrest Assy

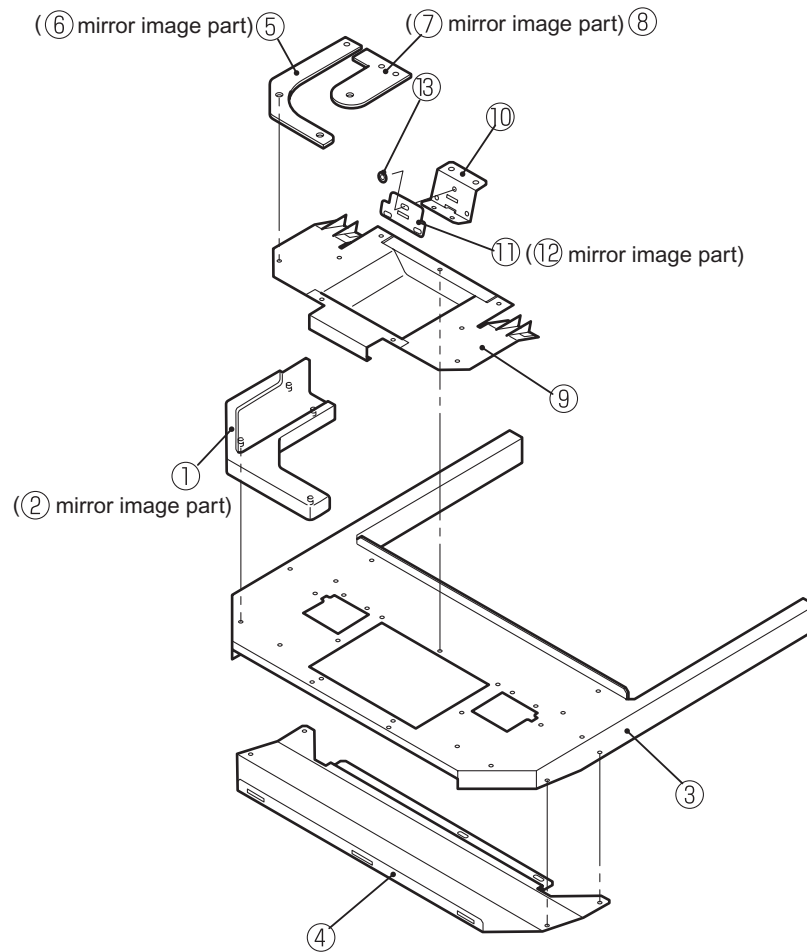

Item	Description	Part No
1	Armrest (L)	XPMB-705-560
2	Armrest (R)	XPMB-705-561
3	Armrest Base	XPMB-705-562
4	Underpanel	XPMB-707-951
5	Acrylic Tray A (L)	XPMB-707-952
6	Acrylic Tray A (R)	XPMB-707-953
7	Acrylic Tray B (L)	XPMB-707-954
8	Acrylic Tray B (R)	XPMB-707-955
9	Coin Tray	XPMB-707-568
10	Enter Plate	XPMB-705-569
11	Coin Adjuster (L)	XPMB-705-570
12	Coin Adjuster (R)	XPMB-705-571
13	Button Washer	XPMB-705-572

8-6 Playfield Assy

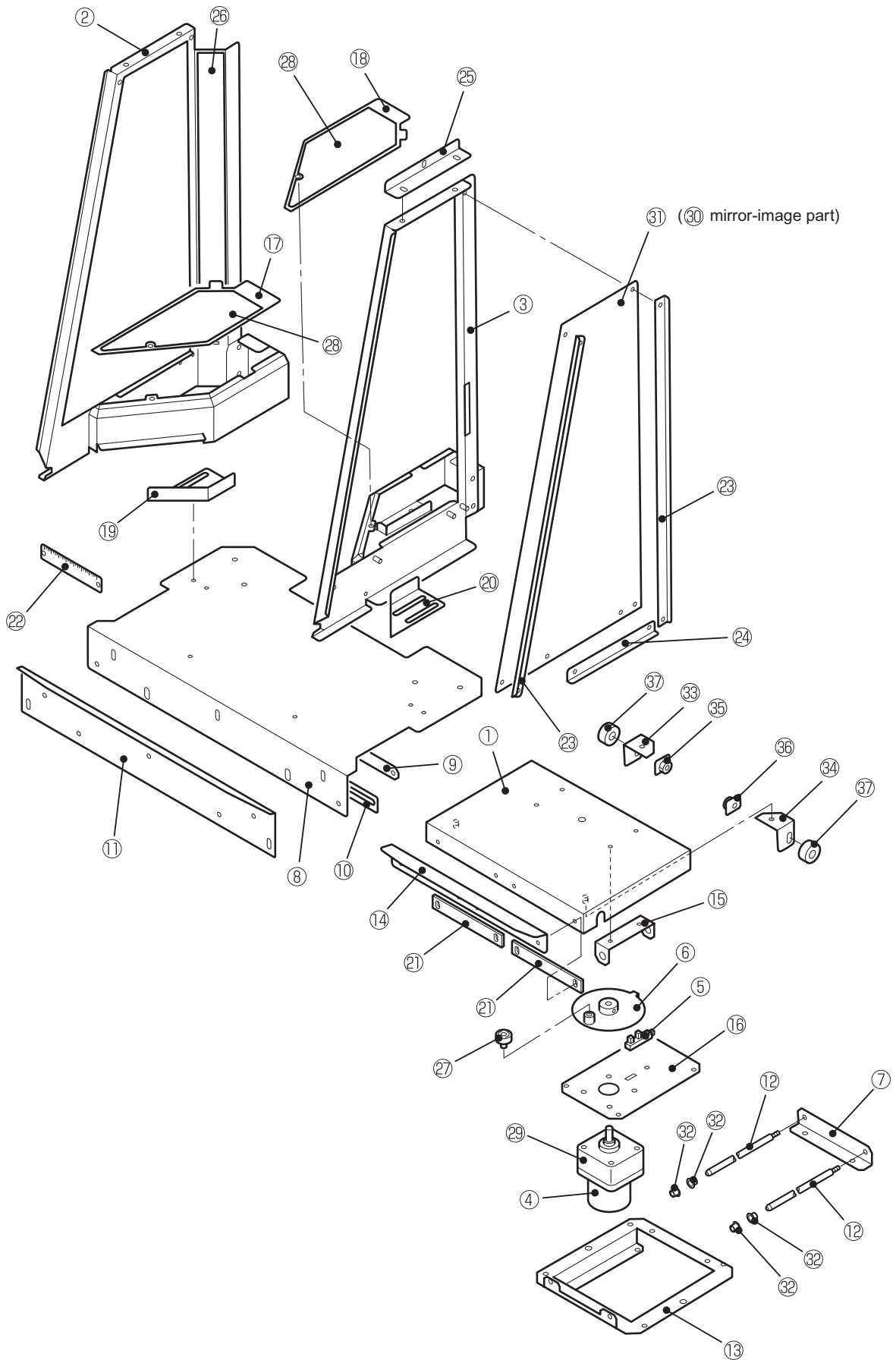

Item	Description	Part No
1	Pusher Table	XPMB-707-480
2	Pillar Stage L	XPMB-707-940
3	Pillar Stage R	XPMB-707-941
4	Pusher Motor (IM-H6A6ZV573)	XPMB-005-293
5	Pusher Sensor (OJ-796021-701)	XPMB-000-279
6	Pusher Crank	XPMB-705-483
7	Pusher Guide Bracket	XPMB-705-484
8	Field Base	XPMB-707-957
9	Edge Plate	XPMB-705-486
10	Edge Slider	XPMB-705-487
11	Front Edge	XPMB-705-488
12	Pusher Shaft	XPMB-705-489
13	Pusher Base	XPMB-705-490
14	Pusher Edge	XPMB-705-491
15	Bearing Support	XPMB-705-492
16	Pusher Motor Bracket	XPMB-705-493
17	Stage Plate L	XPMB-705-494
18	Stage Plate R	XPMB-705-495
19	Side Edge L	XPMB-705-496
20	Side Edge R	XPMB-705-497
21	Scraper	XPMB-705-498
22	Edge Gauge	XPMB-705-499
23	Side Panel Bracket A	XPMB-705-500
24	Side Panel Bracket B	XPMB-705-501
25	Pillar Stage Bracket	XPMB-705-502
26	Pillar Decal L, R set	XPMB-707-944
27	Bearing (DR-22-B3)	XPMB-103-026
28	Table Side Decal L, R set	XPMB-707-945
29	Gear Head (6RH-DZ100V573)	XPMB-005-294
30	Side Panel L	XPMB-705-507
31	Side Panel R	XPMB-705-508
32	Flange Bushing (80F-0803)	XPMB-250-728
33	Bearing Support Bracket L	XPMB-705-531
34	Bearing Support Bracket R	XPMB-705-532
35	Nut Plate L	XPMB-705-533
36	Nut Plate R	XPMB-705-534
37	Bearing (DR-22-H6W1)	XPMB-103-160

8-7 Play Panel Assy

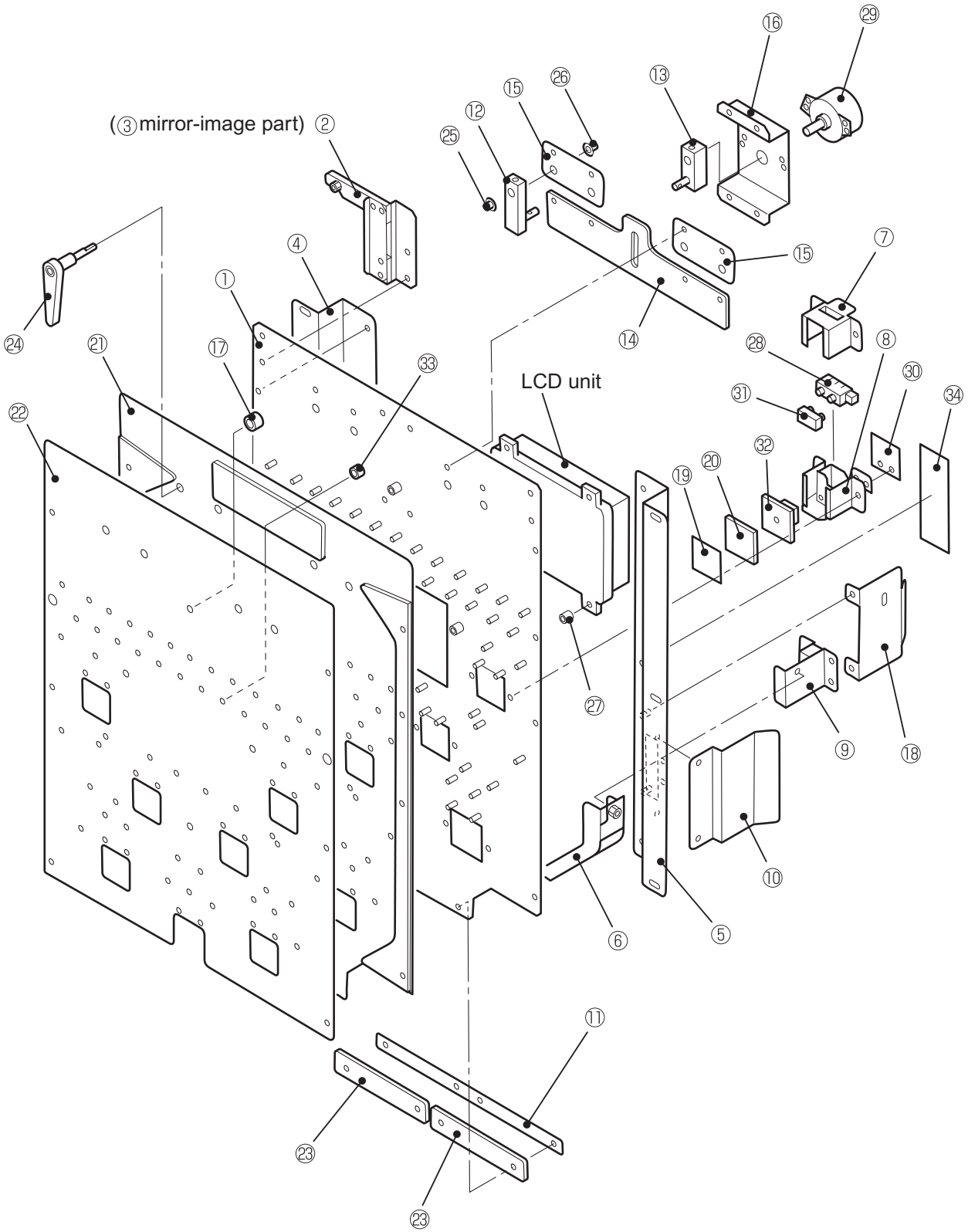

Item	Description	Part No
1	Main Panel Base	XPMB-705-510
2	Chute Guide L	XPMB-705-511
3	Chute Guide R	XPMB-705-512
4	Panel Angle L	XPMB-705-513
5	Panel Angle R	XPMB-705-514
6	Bonus Exit	XPMB-705-515
7	Checker Cover	XPMB-705-516
8	Checker Base	XPMB-705-517
9	Bonus Hopper IN	XPMB-705-518
10	Bonus Hopper Stopper	XPMB-705-519
11	Scraper Holder	XPMB-705-520
12	Wiper Base Block	XPMB-705-521
13	Wiper Motor Crank	XPMB-705-522
14	Wiper Link Plate	XPMB-705-523
15	Wiper Bracket	XPMB-705-524
16	Wiper Motor Bracket	XPMB-705-525
17	Panel Spacer	XPMB-705-526
18	Bonus Hopper Stopper B	XPMB-705-527
19	Checker Stickers (1-7) set	XPMB-707-946
20	Checker Filter	XPMB-705-528
21	Main Panel	XPMB-707-947
22	Main Panel Cover	XPMB-705-530
23	Scraper	XPMB-705-498
24	Wiper	XPMB-691-485
25	Flange Bushing (80F-0503)	XPMB-104-005
26	Flange Bushing (80F-0403)	XPMB-104-002
27	Duracon Spacer (C-307)	XPMB-103-159
28	Checker Sensor (EON-S041-701)	XPMB-000-529
29	Wiper Motor (D125J62-27)	XPMB-005-324
30	Sensor PC Board	XPMB-306-418
31	Prism (E-3674)	XPMB-000-530
32	LED PC Board	XPMB-306-413
33	Duracon Spacer (C305)	XPMB-110-029
34	Escalator Sticker	XPMB-707-948

8-8 Coin Selector (L), (R) Assys

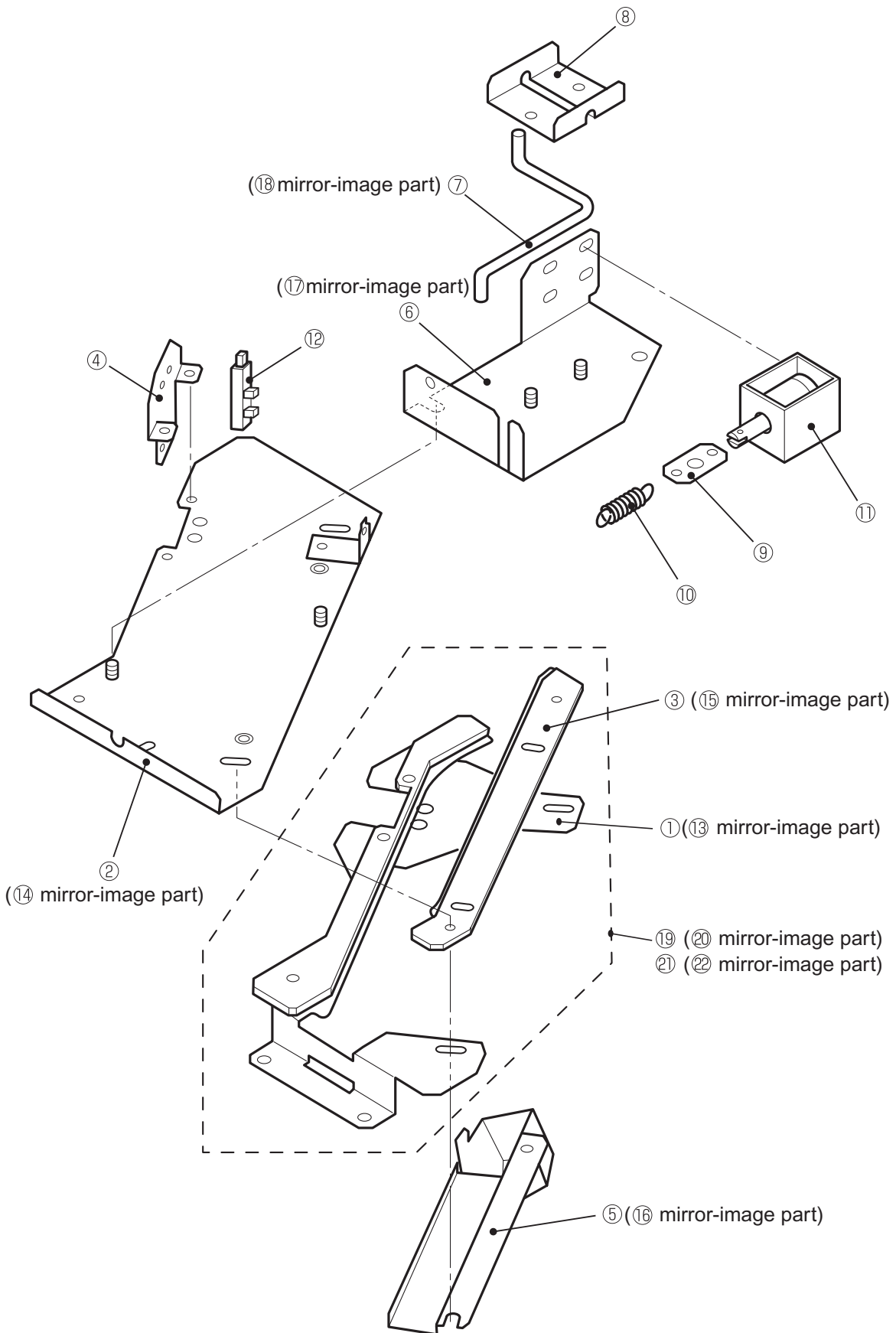

Item	Description	Part No
1	Selector Base (L)	XPMB-705-580
2	Upper Plate (L)	XPMB-705-581
3	Adjuster Plate (L)	XPMB-705-582
4	Twin-Sensor Holder	XPMB-705-583
5	Coin OUT (L)	XPMB-705-584
6	Lock-Out Base	XPMB-705-585
7	Lock-Out Pin	XPMB-705-586
8	Pin Holder	XPMB-705-587
9	Joint Plate	XPMB-705-588
10	Spring (2107)	XPMB-105-145
11	LockOut Solenoid (TDS-06A-4025)	XPMB-004-627
12	Coin Sensor (OJ-796021-701)	XPMB-000-279
13	Selector Base (R)	XPMB-705-590
14	Upper Plate (R)	XPMB-705-591
15	Adjuster Plate (R)	XPMB-705-592
16	Coin OUT (R)	XPMB-705-593
17	Lock-Out Base (R)	XPMB-705-594
18	Lock-Out Pin (R)	XPMB-705-595
19	Selector Base Set (L) (2-pence, set containing Nos. 1 and 3)	XPMB-705-6156
20	Selector Base Set (R) (2-pence, set containing Nos. 13 and 15)	XPMB-705-617
21	Selector Base Set (L) (10-pence, set containing Nos. 1 and 3)	XPMB-705-616
22	Selrctor Base Set (R) (10-pence, set containing Nos. 13 and 15)	XPMB-705-618

8-9 Payout Assys

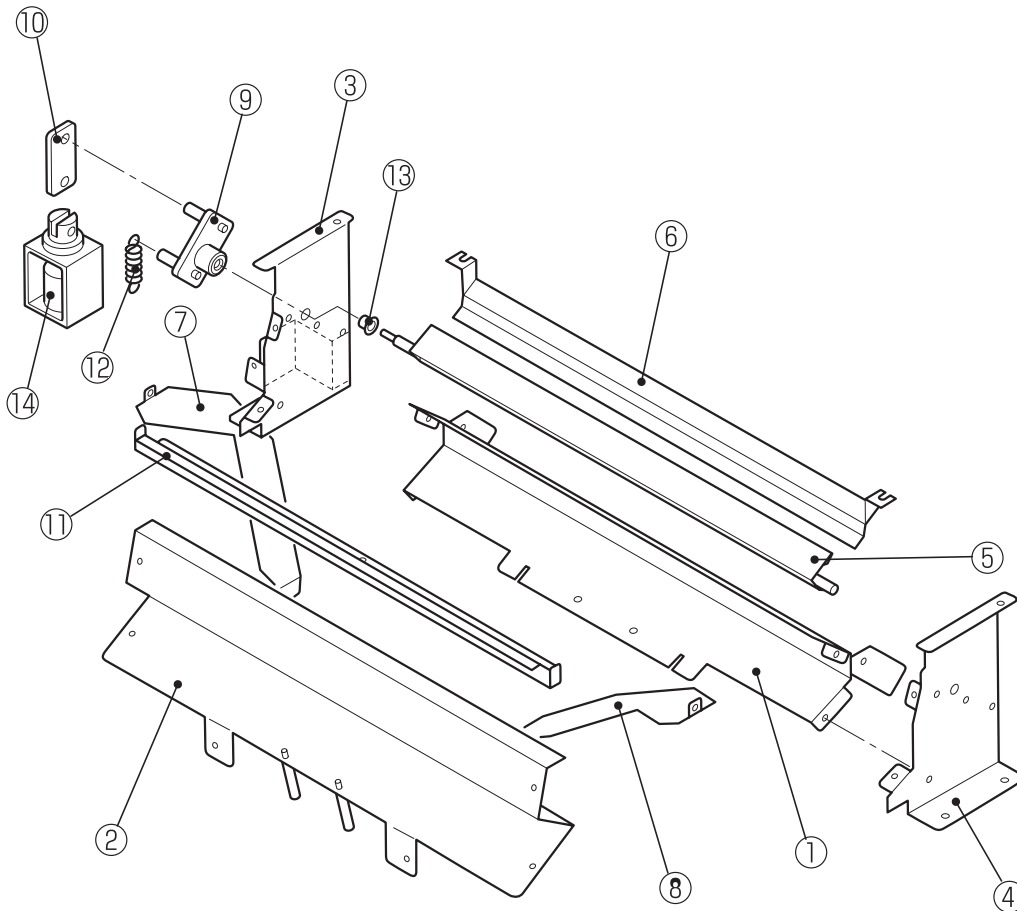

Item	Description	Part No
1	Rear	XPMB-705-540
2	Front	XPMB-705-541
3	Side (L)	XPMB-705-542
4	Side (R)	XPMB-705-543
5	Divider	XPMB-705-544
6	Top	XPMB-705-545
7	Slope (L)	XPMB-705-546
8	Slope (R)	XPMB-705-547
9	Block	XPMB-705-548
10	Solenoid Plate	XPMB-705-549
11	Front L Guard	XPMB-705-550
12	Spring (2146)	XPMB-105-019
13	Flange Bushing (8F-0603)	XPMB-258-382
14	Payout Solenoid (T1578213)	XPMB-004-629

8-10 Coin Divider (L), (R) Assys Assys

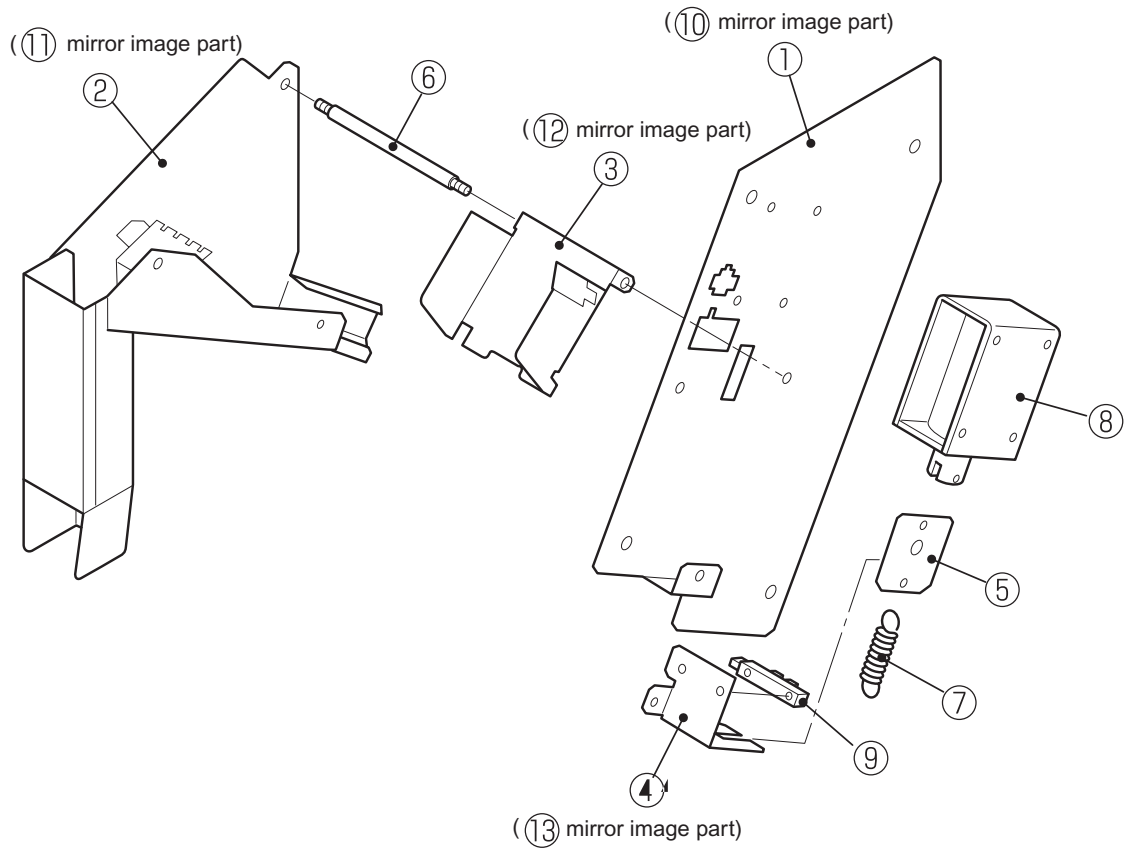

Item	Description	Part No
1	Divider Base (L)	XPMB-705-600
2	Slope Base (L)	XPMB-706-601
3	OUT Slope (L)	XPMB-705-602
4	Sensor Holder (L)	XPMB-705-603
5	Joint	XPMB-705-604
6	Shaft Pin	XPMB-705-605
7	Spring (2106)	XPMB-105-146
8	Divider Solenoid (TDS-12E-5003)	XPMB-004-628
9	Divider Solenoid Sensor (OJ-796021-701)	XPMB-000-279
10	Divider Base (R)	XPMB-705-610
11	Slope Base (R)	XPMB-705-611
12	OUT Slope (R)	XPMB-705-612
13	Sensor Holder (R)	XPMB-705-613

9-1 Cabinet Assy

- Observe the following:
1. Dimensions specified in the harness diagrams shall take precedence. Figures in parentheses in the connection diagrams are reference dimensions.
 2. Thick green/yellow, thick and thin lines represent AWG16, AWG18, and AWG24, respectively, unless otherwise specified.
 3. Miniature universal MATE-N locking connectors are used, unless otherwise specified.
 4. Connectors with "-C" indication are cap connectors, and connectors with "-P" indication are plug connectors.
 5. Pin contact is used for cap connectors, and socket contact is used for plug connectors.

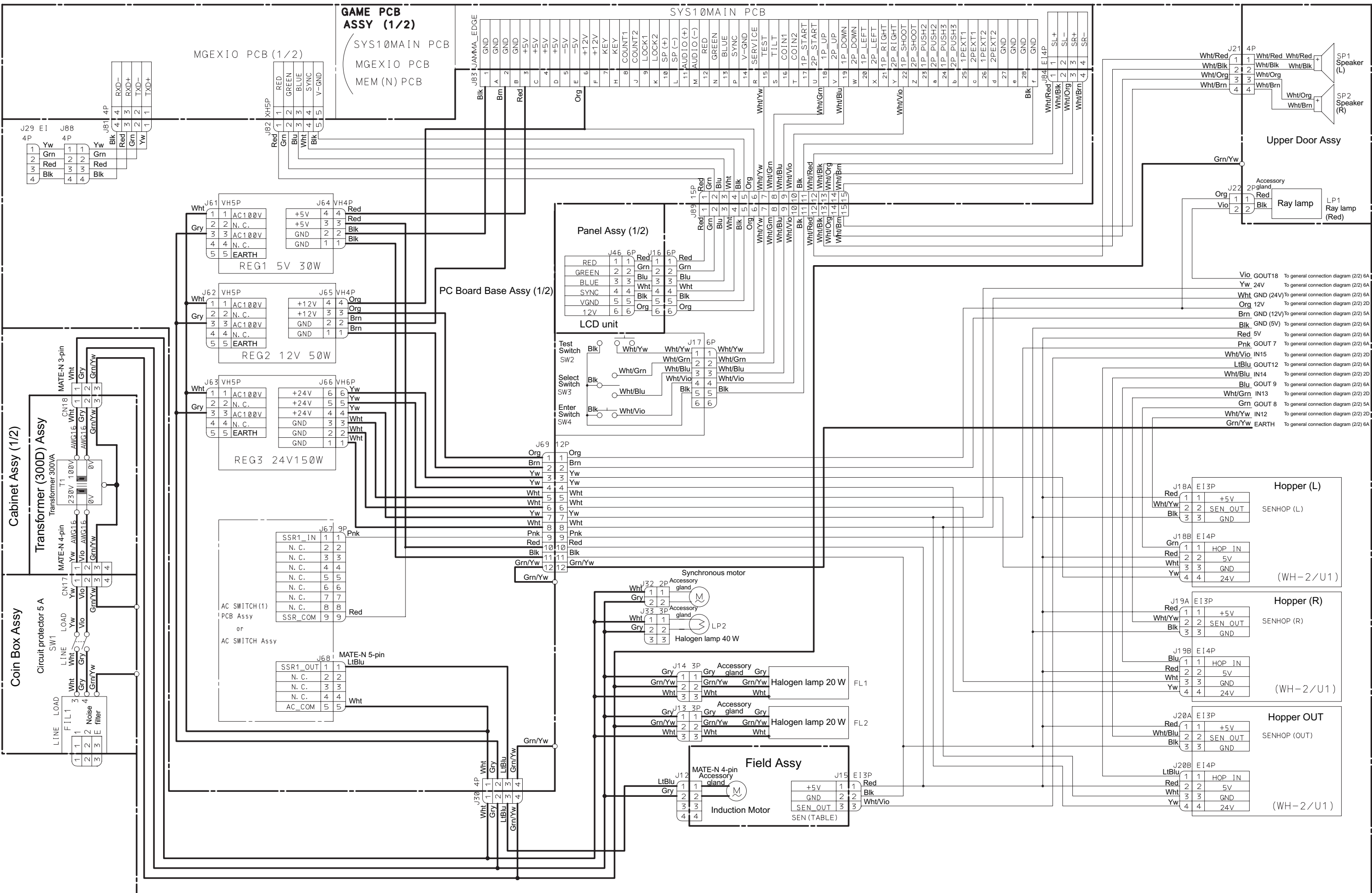

9-2 Game PCB Base Assy

MGEXIO PCB (2/2)

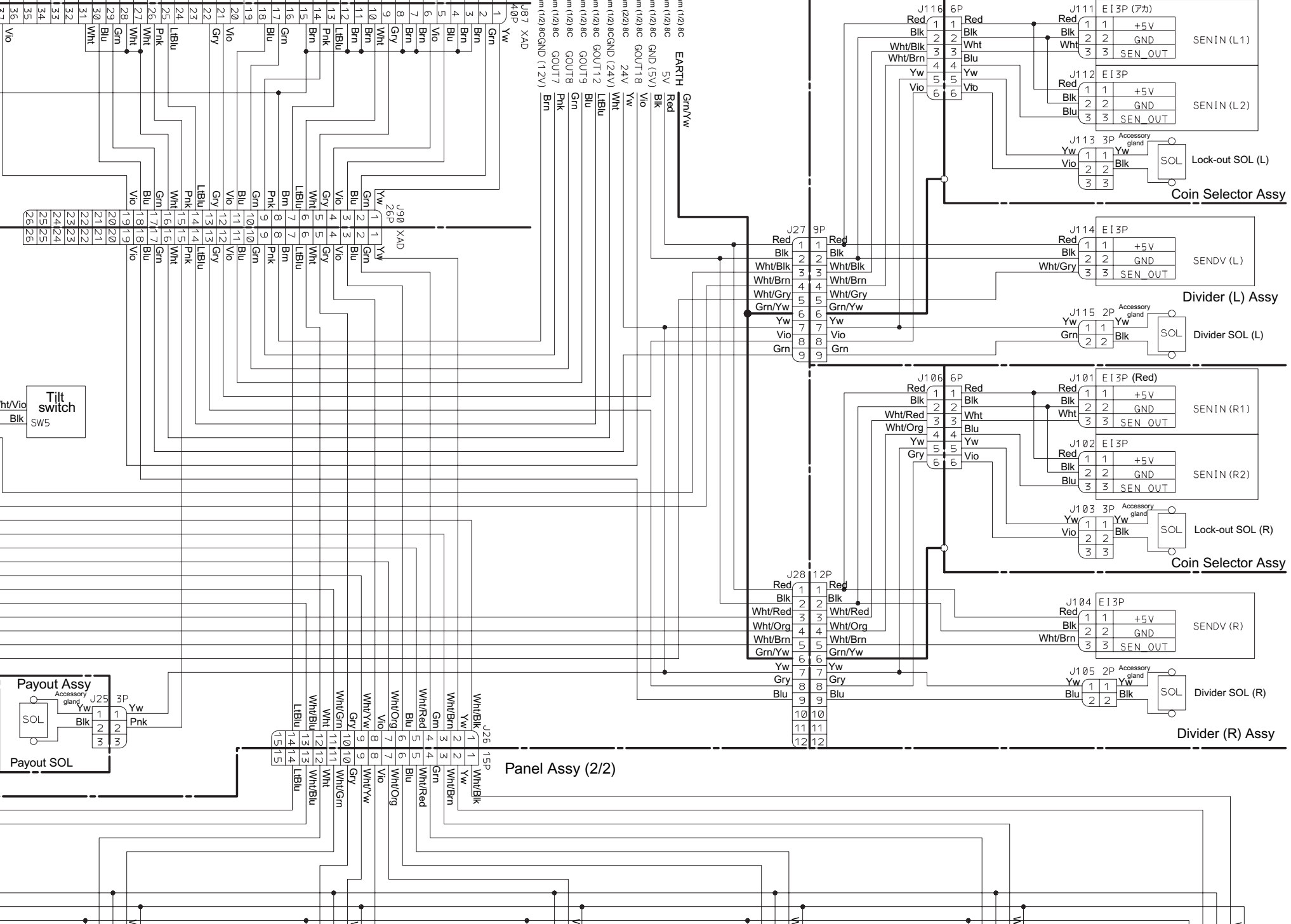
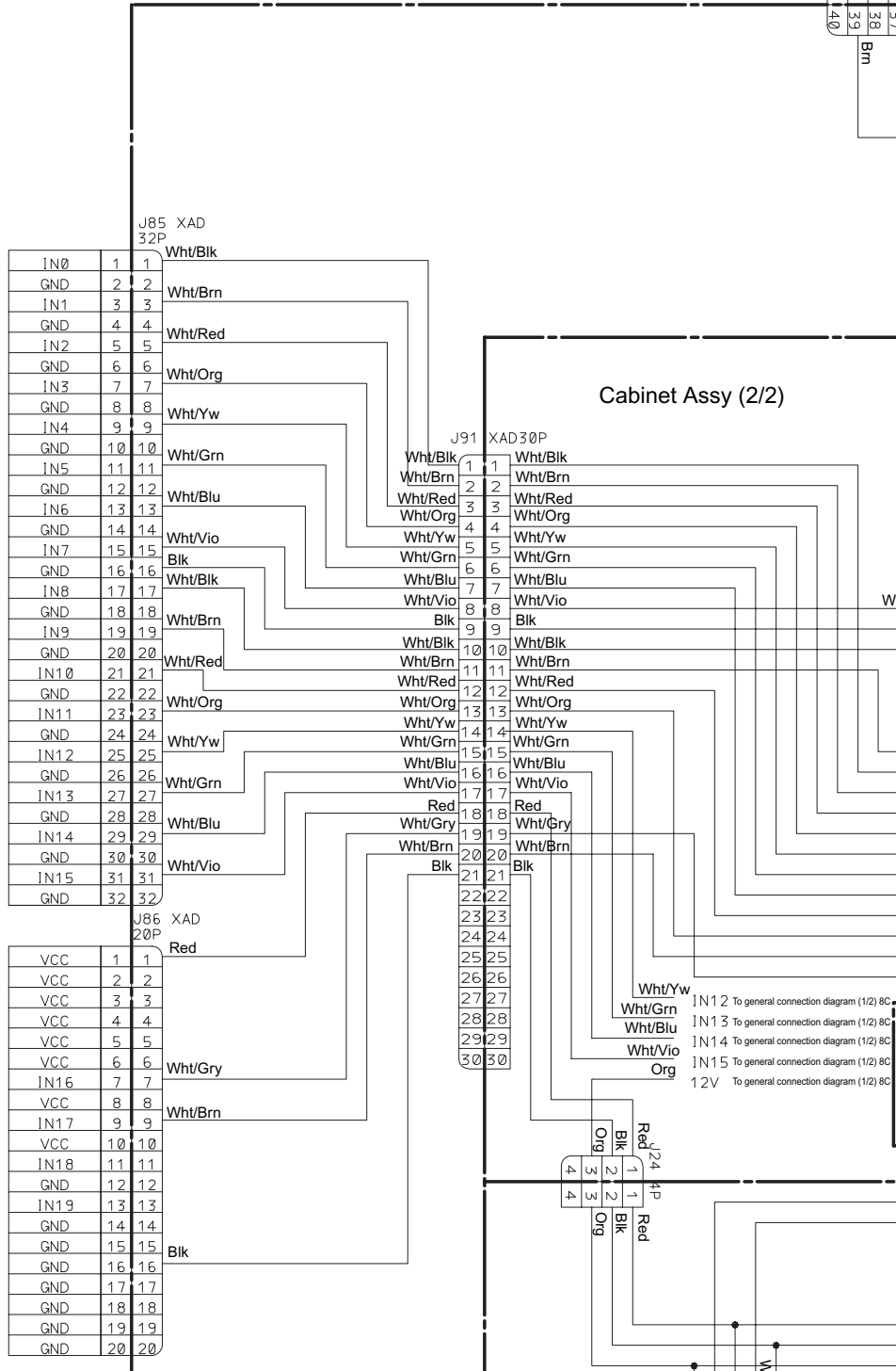

Observe the following:
 1. Dimensions specified in the harness diagrams shall take precedence. Figures in parentheses in the connection diagrams are reference dimensions.
 2. Thick green/yellow, thick and thin lines represent AWG16, AWG18, and AWG24, respectively, unless otherwise specified.
 3. Miniature universal MATE-N locking connectors are used, unless otherwise specified.
 4. Connectors with "C" indication are cap connectors, and connectors with "P" indication are plug connectors.
 5. Pin contact is used for cap connectors, and socket contact is used for plug connectors.

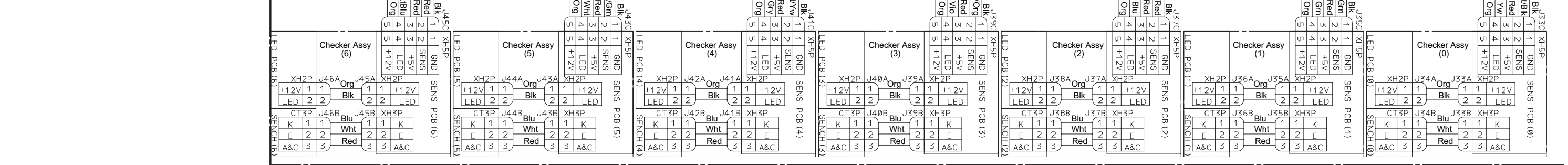

Copies of Namco Game Manuals can be downloaded from our website:
www.namco.co.uk under Components Distribution

For all Parts or Technical Support contact:

Brent Electronic,
Namco House,
Units 7-8, Acton Park Estate,
The Vale,
London. W3 7QE

www.brentelectronic.co.uk

For Technical Support, Warranty and

Advance Replacement Parts:-  +44 (0) 20 8324 6120

For Consumable Parts:-  +44 (0) 20 8324 6102

Fax for both:-  +44 (0) 20 8324 6126