

Ålands Penningautomatförening  
MARIEHAMN, ÅLAND, FINLAND

TYPE: SEG.VIR SERIAL: 5104  
SL. A, VIRTUA RACING TWIN

1ST PRINTING-SP

230 Volt AC 50 Hertz  
680 Watt

# SEGA

# Virtua Racing

## OWNER'S MANUAL

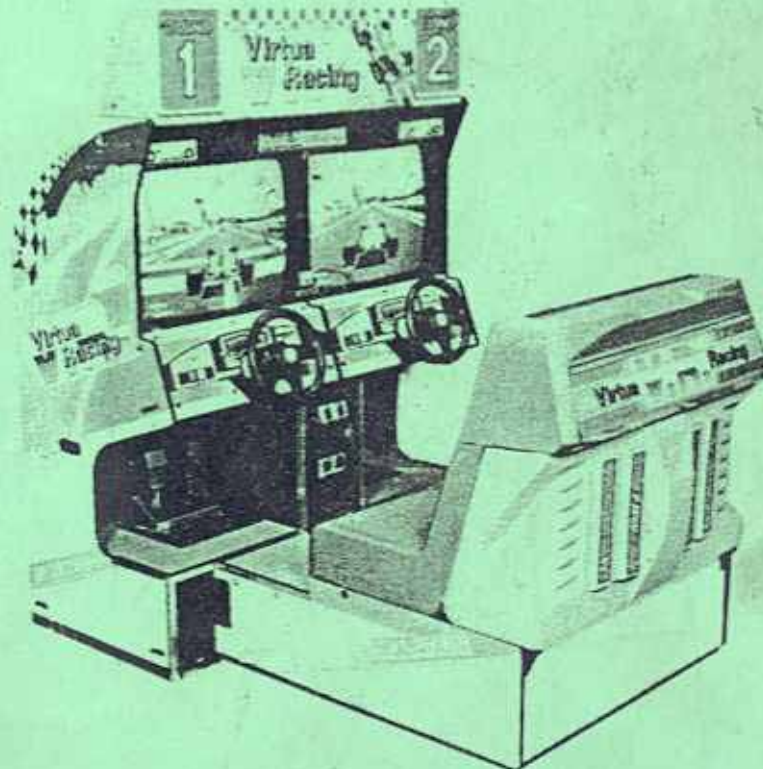

## SEGA ENTERPRISES, LTD.

## SEGA VIRTUA RACING

Built under license in the UK by Deith Leisure Manufacturing

The SEGA VIRTUA RACING ('Twin' Model) is a revised version of the Japanese specification machine detailed in this manual. Modifications have been made to facilitate European operation and include changes in the cabinet layout. Therefore some key components will be found to be different from those detailed in the original manual.

Monitors	-	Two Wells-Gardner 25" medium resolution monitors with automatic de-gauss
Coin handling	-	1 x Coin Controls Sentinel C220, or 2 x G15 National Rejector (Germany), or 2 x Coin Controls S10 (mechanical)
	-	CREDY-2 credit board, or 2 x Nova Creditboard B915 (Germany)
Coin meter	-	One mechanical meter for each mech
Car No. Lamps	-	40W 110V gls bc fitting
Pedal unit	-	Modified vertical mounting type
Wiring Harness	-	Power distribution and coin handling looms modified for European operation
Mains input	-	Deith multi-switch bracket, IEC plug with fuse (20mm 10A), 10A rfi filter
Power supply	-	2 x 15A switch-mode power supply
	-	860VA toroidal multi-tapped transformer
Dimensions	-	1480 x 1260 x 1700mm
Supply	-	220-240 VAC 50 Hz
Power	-	680 W

The basic operation of this machine remains as detailed in the owner's manual, and the machine will have been set up for normal 2 player interactive operation prior to delivery.

Note: The following pages have intentionally been omitted from this manual: 30; 31; 50; 51; 52; 53; 54; 85; 86; 87; 96 & 97.

DEITH LEISURE MANUFACTURING (November 1992)

This information is subject to change without notice

## TABLE OF CONTENTS

INTRODUCTION OF THE OWNER'S MANUAL	
1. HANDLING PRECAUTIONS .....	1
2. PREVENTION OF COUNTERFEITING AND CONVERSION .....	2
3. PRECAUTIONS CONCERNING INSTALLATION LOCATION .....	3
4. NAME OF PARTS .....	4
5. ACCESSORIES .....	5
6. METHOD OF INSTALLATION AND ASSEMBLY .....	6~ 8
7. POWER ON CHECK .....	9~10
8. SW UNIT .....	11
9. TEST MODE .....	12~24
10. ACCEL & BRAKE (ACCELERATOR & BRAKE) .....	25~26
11. HANDLE (CONTROL PANEL) .....	27~29
12. ADJUSTMENT OF THE 26" MONITOR .....	30
13. REPLACEMENT OF FAN MOTOR BRUSHES .....	31
14. REPLACEMENT OF FLUORESCENT LAMP, AND LAMPS .....	32
15. PERIODIC CHECK .....	32
16. DESIGN RELATED PARTS .....	33
17. COMMUNICATIONS (LINK) PLAY .....	34~41
18. PARTS LIST .....	42~97
19. WIRE COLOR CODE TABLE .....	98
20. WIRING DIAGRAM .....	99~103

### SPECIFICATIONS

Installation space	: 1,260 mm (49.6 in.) (W) × 1,750 mm (68.9 in.) (D)
Height	: 1,760 mm (69.3 in.)
Weight	: Approx. 260 kg. (573 lbs.)
Power, Maximum current	: 653W 7.0A (AC 110V 50 Hz)
	662W 7.1A (AC 110V 60 Hz)
	668W 6.9A (AC 120V 60 Hz)
	653W 3.9A (AC 220V 50 Hz)
	660W 4.3A (AC 220V 60 Hz)
	655W 3.8A (AC 240V 50 Hz)
	663W 4.2A (AC 240V 60 Hz)
CRT	: 26" MONITOR × 2

NOTE : Descriptions in this manual are subject to change without prior notice.



## INTRODUCTION OF THE OWNER'S MANUAL

SEGA ENTERPRISES, LTD. supported by its high electronic technology of LSIs, microprocessors, etc. and a wealth of experience, has been supplying various innovative and popular game machines to the world market. This Owner's Manual is intended to provide detailed descriptions together with all the necessary information covering the general operation of electronic assemblies, electromechanical servicing controls, spare parts, etc. in regards to the new Sega product, VIRTUA RACING TWIN.

This manual is intended for those who have knowledge of electricity and technical expertise especially in ICs, CRTs, microprocessors, etc. Carefully read this manual to acquire sufficient knowledge before working on the machine. Should there be a malfunction, non-technical personnel should under no circumstances touch the interior system. Should such a case arise, contact our Main Office or the closest branch office listed as follows :

### SEGA ENTERPRISES, INC. (U. S. A.)

2148 Paragon Dr., P.O. Box 610550, San Jose, CA 95161-0550, U. S. A  
Phone : (408) 435-0201  
Fax : (408) 435-0294

### SEGA AMUSEMENTS EUROPE LIMITED

6 Churchill Court, 58 Station Road, North Harrow, Middlesex HA27SA, England  
Phone : 081-863 7737  
Fax : 081-863 5354

### SEGA SOUTHERN EUROPE LIAISON OFFICE

Calle Vallellano, 19-23, 1° A, 370080-Salamanca, Spain  
Phone : (923) 265893  
Fax : (923) 265913



## 1. HANDLING PRECAUTIONS

Pay close attention to the followings points when installing or inspecting the game to ensure that the players can enjoy it safely.

- Be sure to turn off the power before working on the machine.
- It is dangerous to insert and pull out the plug quickly.
- It is necessary to make sure that the power cord or the ground wire is not exposed out in the open where it may be dangerous. Care should be taken so that grounding connections are made safely at locations specified.
- Do not use fuses which do not meet specified ratings.
- Make complete connections of the IC board and other connectors.  
Insufficient insertion is very dangerous.  
For inspection of IC board circuits, only the logic tester is allowed.  
Keep in mind that the usage of a tester is not permitted.
- The operating (ambient) temperature range is from 5°C to 40°C.

After confirming that there is no abnormality, turn on the power.

## 2. PREVENTION OF COUNTERFEITING AND CONVERSION

### ◆ LABELLING

The following labels are affixed to all SEGA products to prevent counterfeits and conversions. When handling such products, be sure to confirm the labels. They are used to prevent illegal acts such as unauthorized duplication of products and printed circuit boards and carrying on businesses where similar merchandise is manufactured or the products are converted and sold.

#### ORIGINAL SEAL

The following seal is put on all machines manufactured by SEGA.



### ◆ Copyright notice

SEGA product has the following copyright notice.

© SEGA 1992

This signifies that this work was disclosed in 1992 and is the property of SEGA ENTERPRISES, LTD.

### 3. PRECAUTIONS CONCERNING INSTALLATION LOCATION

VIRTUA RACING TWIN is an indoor game machine.

Under no circumstances should it be installed outdoors. Even indoors, avoid installing in areas mentioned below to ensure proper operation.

- Areas subject to rain, water leakage, or condensation due to humidity.
- In the proximity of an indoor swimming pool and/or showers.
- Areas subject to direct sunlight.
- Areas subject to direct heat from heating units or the like and/or hot air.
- Vicinity of highly flammable/volatile chemicals or hazardous matters.
- Slanted surfaces.
- Vicinity of fire prevention facilities such as emergency exits and fire extinguishers.
- Areas subject to any strong vibrations.
- Dusty areas.

#### INSTALLATION PRECAUTIONS

- 1) Do not share the power plug socket with any other electric appliances.
- 2) The per unit standard voltage/ampereage is 100~120V/10A and 200~240V/5A.
- 3) If an extension cord is to be used, use a cord of 10A or higher rating.

#### Electric current consumption

MAX. 7.0A (AC 110V 50 Hz)
MAX. 7.1A (AC 110V 60 Hz)
MAX. 6.9A (AC 120V 60 Hz)
MAX. 3.9A (AC 220V 50 Hz)
MAX. 4.3A (AC 220V 60 Hz)
MAX. 3.8A (AC 240V 50 Hz)
MAX. 4.2A (AC 240V 60 Hz)



#### 4. NAME OF PARTS

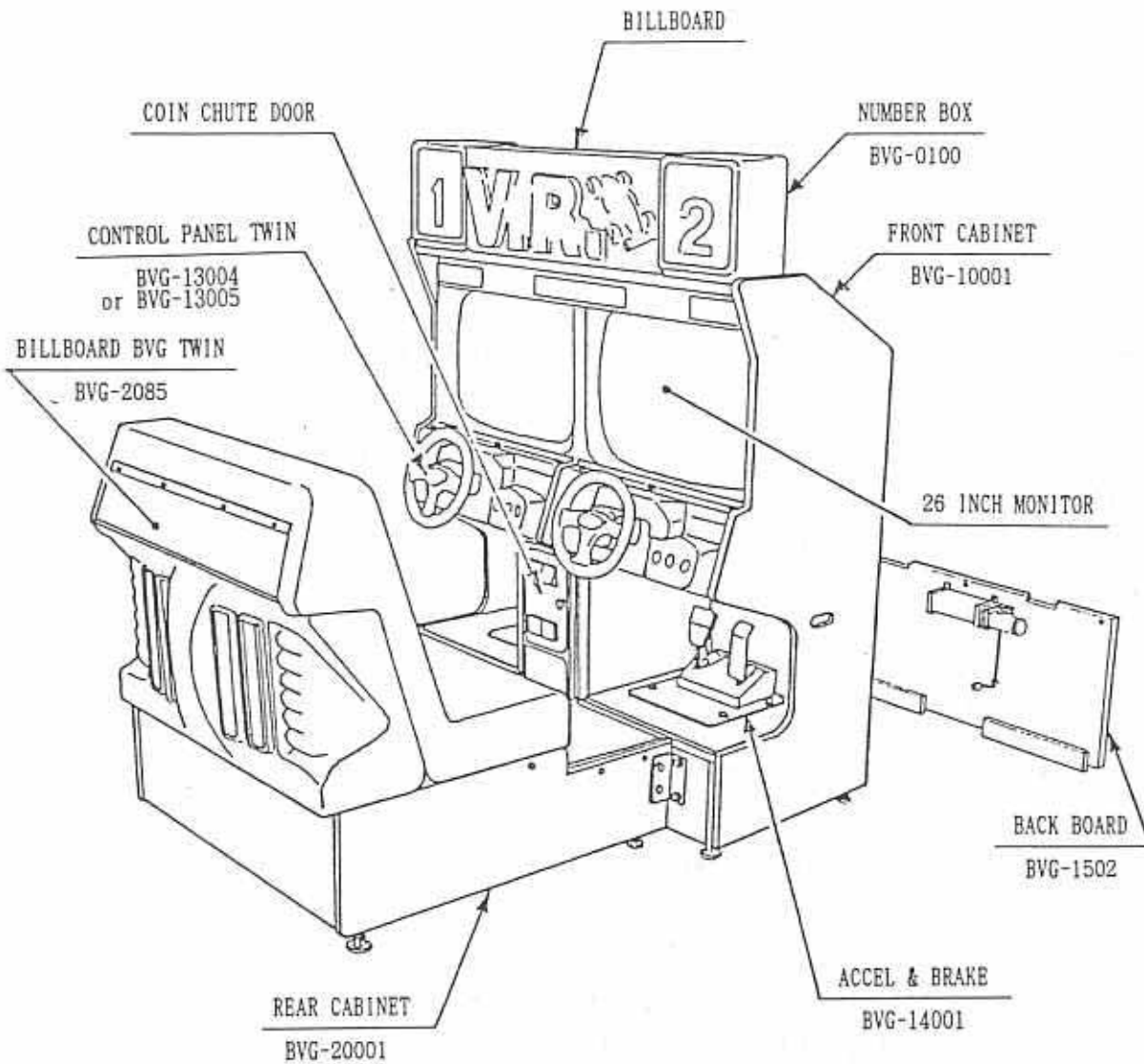

Note : The ACCELERATOR is hereinafter referred to as "ACCEL."

#### Dimensions and weight

	Depth	×	Width	×	Height (mm)	Weight(kg)
FRONT CABINET	780	×	1,260	×	1,760	Approx. 163
REAR CABINET	1,120	×	960	×	1,080	Approx. 97
COMPLETE CABINET	1,750	×	1,260	×	1,760	Approx. 260

## 5. ACCESSORIES

PART No.	Qty	DESCRIPTION	
BVG-0017-03	1	NUMBER PLATE 3	
BVG-0017-04	1	NUMBER PLATE 4	
BVG-0017-05	1	NUMBER PLATE 5	
BVG-0017-06	1	NUMBER PLATE 6	
BVG-0017-07	1	NUMBER PLATE 7	
BVG-0017-08	1	NUMBER PLATE 8	
BVG-1019	1	STICKER FRONT GLASS NO3	
BVG-1020	1	STICKER FRONT GLASS NO4	
BVG-1021	1	STICKER FRONT GLASS NO5	
BVG-1022	1	STICKER FRONT GLASS NO6	
BVG-1023	1	STICKER FRONT GLASS NO7	
BVG-1024	1	STICKER FRONT GLASS NO8	
INST NO. 587-01	1	INSTALLATION INSTR VIRTUA RACING TWIN ENG	
220-5130	1	VOL CONT B-5K OHM	
390-5412	1	LAMP 110V 25W	
420-6056-02	1	OWNERS MANUAL VIRTUA RACING TWIN ENG	
420-5962	1	DSPL MANUAL 26" 200-5187 ENG	
420-5963		DSPL MANUAL 26" 200-5195 ENG	
514-5036-10000	1	FUSE $\phi 6.4 \times 30$ 10000mA 125V	AC100~120V AREA
514-5037-7000		FUSE $\phi 6.4 \times 30$ 7000mA 250V	AC220~240V AREA
540-0006-01	1	WRENCH FOR TAMP PRF SCR DUAL TYPE M4	
540-0007-01	1	WRENCH FOR TAMP PRF SCR DUAL TYPE M5	
540-0015-01	1	WRENCH FOR TAMP PRF SCR DUAL TYPE M6	

TOOL

(TAMPERPROOF WRENCH)

M4 540-0006-01

M5 540-0007-01

M6 540-0015-01

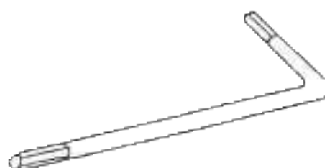

## 6. METHOD OF INSTALLATION AND ASSEMBLY

- ① Remove the two SHIPPING BRACKETS (red) from the FRONT CABINET by taking off 2 hexagon bolts (black) for each.
- ② Connect the connector and then secure the BILLBOARD BOX by using the 2 hexagon bolts (black).
- ③ Using the 8 tamperproof screws, secure the TOP PANEL LIGHT to the BILLBOARD BOX.
- ④ Using the 4 tamperproof screws, secure the WIRE COVER to the BILLBOARD BOX.
- ⑤ Install two NUMBER BOXES to the FRONT CABINET. NUMBER BOX NO.1 is to be on the left-hand side (1P side), and NUMBER BOX NO.2, on the right-hand side (2P side). Connect each connector and secure NUMBER BOX NO.1 and NO.2 by using 2 each of the tamperproof screws.

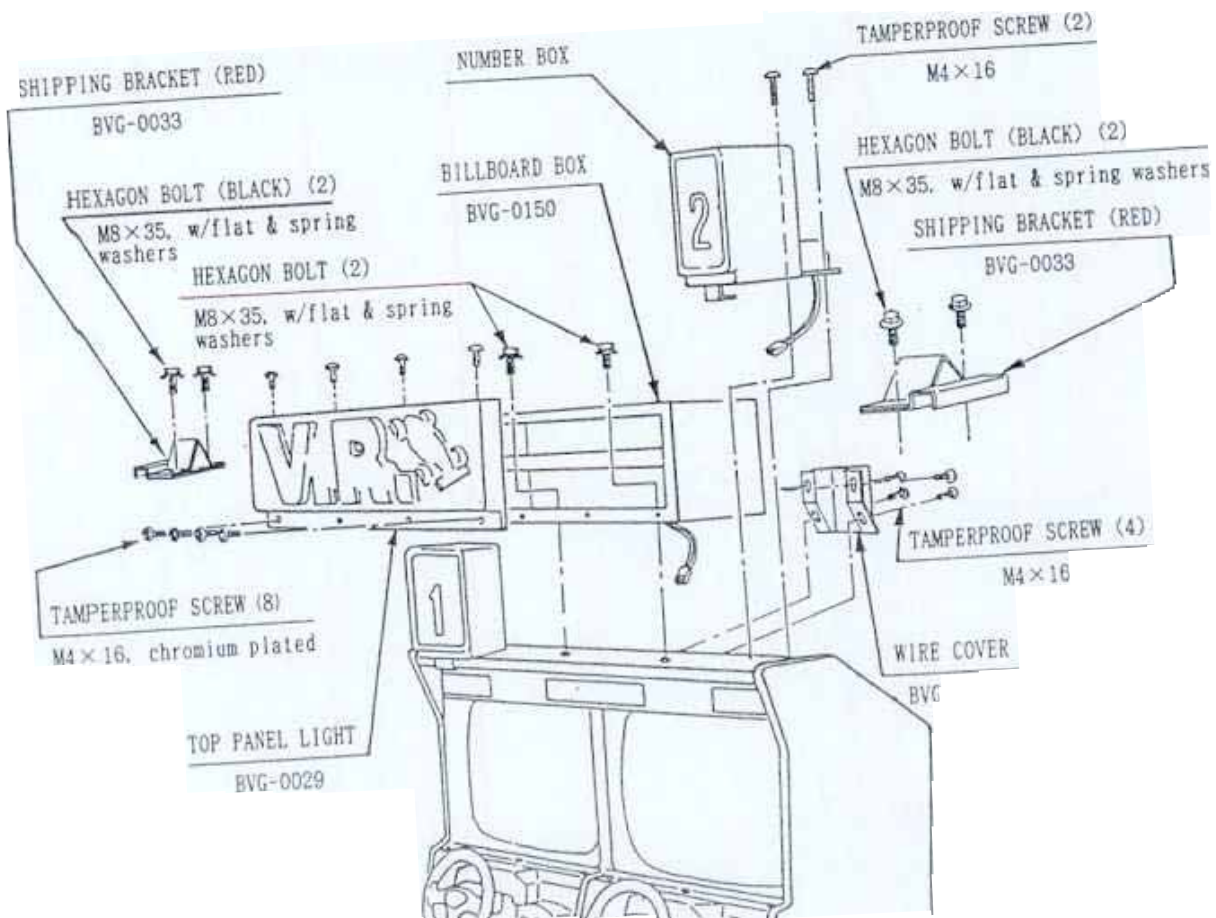



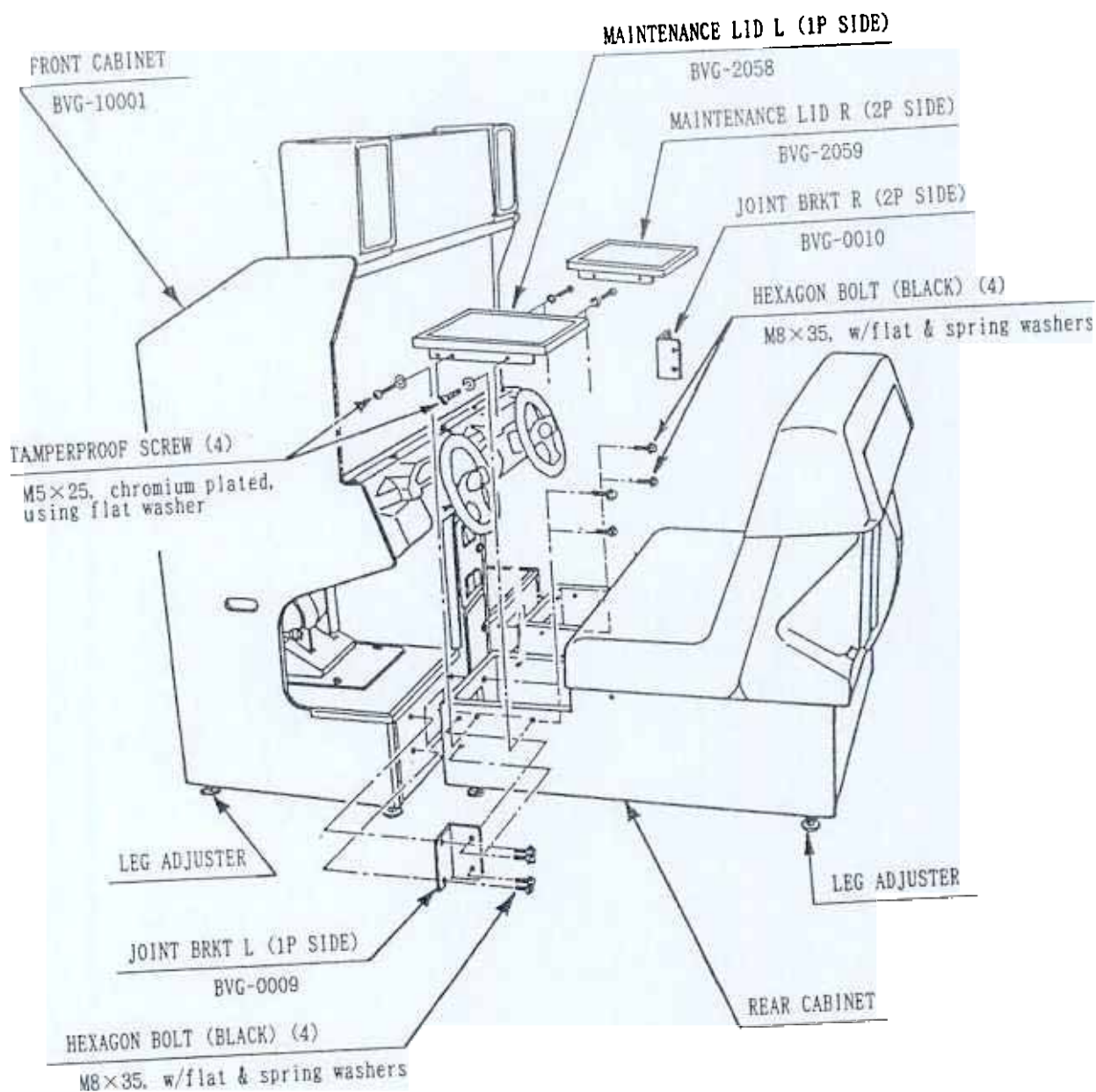

- ⑥ Remove the MAINTENANCE LID L (1P SIDE) and MAINTENANCE LID R (2P SIDE) from the REAR CABINET by taking off the 4 tamperproof screws. When the maintenance lids are removed, the 10 connectors will appear in the 1P SIDE, and the 8 connectors in the 2P SIDE of the REAR CABINET.
- ⑦ Combine the FRONT CABINET and REAR CABINET, paying attention so that the wiring will not be damaged. By using the 4 hexagon bolts (black), secure the above-mentioned combination of the FRONT CABINET and REAR CABINET.
- ⑧ Connect the connectors mentioned in ⑥ above.
- ⑨ Reinstall the MAINTENANCE LID L and MAINTENANCE LID R and secure them by using the 4 tamperproof screws for each.
- ⑩ Install the JOINT BRKT L (1P SIDE) and JOINT BRKT R (2P SIDE) by using the 4 hexagon bolts (black) for each.

⑪ Lower the ADJUSTERS secure the machine unit in place. Make adjustments in a manner that the CASTERS are raised approximately 1/16" from the floor level cause the entire machine to be level.

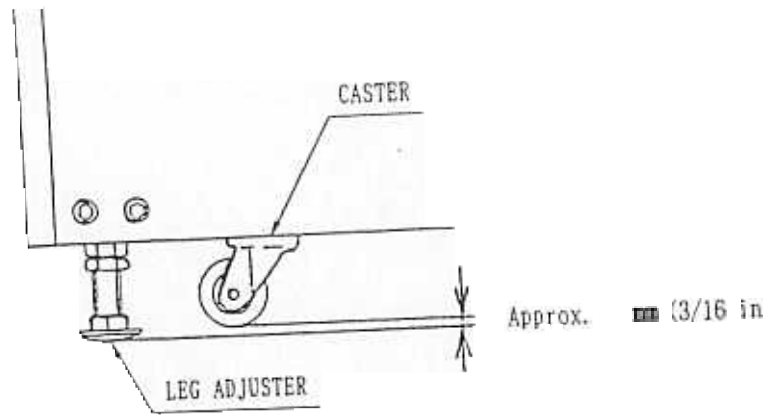

**Machine movement**

When moving the machine, the LEG ADJUSTERS should be retracted so that the CASTERS are in contact with the ground. Where the floor changes level, be sure to separate the FRONT CABINET and REAR CABINET from each other. If the cabinet is lifted without separating them, the cabinet may be damaged.

## 7. POWER ON CHECK

This machine performs various check at the time the power is turned on. The following are the main check items.

### 7-1 NETWORK CHECK

The communications system of this machine allows 1P (the left-hand side player) and 2P (the right-hand side player) to compete against each other. This check is performed at the time the power is turned on or when exiting from the test mode.

```
TEST MODE
START CREDIT xCREDIT START
COIN SETTING xx
CHUTE1: xxCOIN xxCREDIT
CHUTE2: xxCOIN xxCREDIT
CAR COLOR RED
COURSE SELECT MAJORITY VOTE
LINK ID MASTER
RACE MODE NORMAL
COUNTRY U.S
MONITOR 4:3 NORMAL
CABINET 2P LINK
DIFFICULTY NORMAL
EXIT
NETWORK CHECKING
THIS IS MASTER CONTROLLER
```

1P SIDE

```
TEST MODE
START CREDIT xCREDIT START
COIN SETTING xx
CHUTE1: xxCOIN xxCREDIT
CHUTE2: xxCOIN xxCREDIT
CAR COLOR BLUE
COURSE SELECT MAJORITY VOTE
LINK ID SLAVE
RACE MODE NORMAL
COUNTRY U.S
MONITOR 4:3 NORMAL
CABINET 2P LINK
DIFFICULTY NORMAL
EXIT
NETWORK CHECKING
THIS IS SLAVE MACHINE
```

2P SIDE

Several seconds after the power is turned on or exiting from the test mode, if the ADVERTISE mode appears on both the 1P and 2P monitor screens, it is satisfactory.



-2 HANDLE MECHA CHECK

This check is performed at the same time as when the NETWORK CHECK is made. The steering wheel automatically operates at the same time the power is on. Be sure not to touch it. Also, be sure not to enter the test mode or play the game, so as to avoid irregular checking. This check takes approximately one minute. If each of the steering wheels turns to the left and right, then performs centering, it is satisfactory. In the event it does not move at all, or only moves either left or right, the game can not be played satisfactorily. For details, refer to the item of DRIVE BD ERROR DISPLAY in 9. TEST MODE.



## 8. SW UNIT

Open the COIN CHUTE DOOR, and the SW UNIT shown will appear. The functioning of each SW is as follows :

VOLUME CONTROL : Controls the speaker volume.

TEST SW : This is used when entering the test mode. In the test mode, it is used when determining the desired item and also when exiting from each test.

SERVICE SW : Gives credits without registering on the coin meter. In the test mode, it is used when selecting the item.

DEMAGNETIZER SW : Eliminates the unevenness of color from the screen.

The SWes in the following Fig. are also used in the test mode. For each function, refer to the following section.

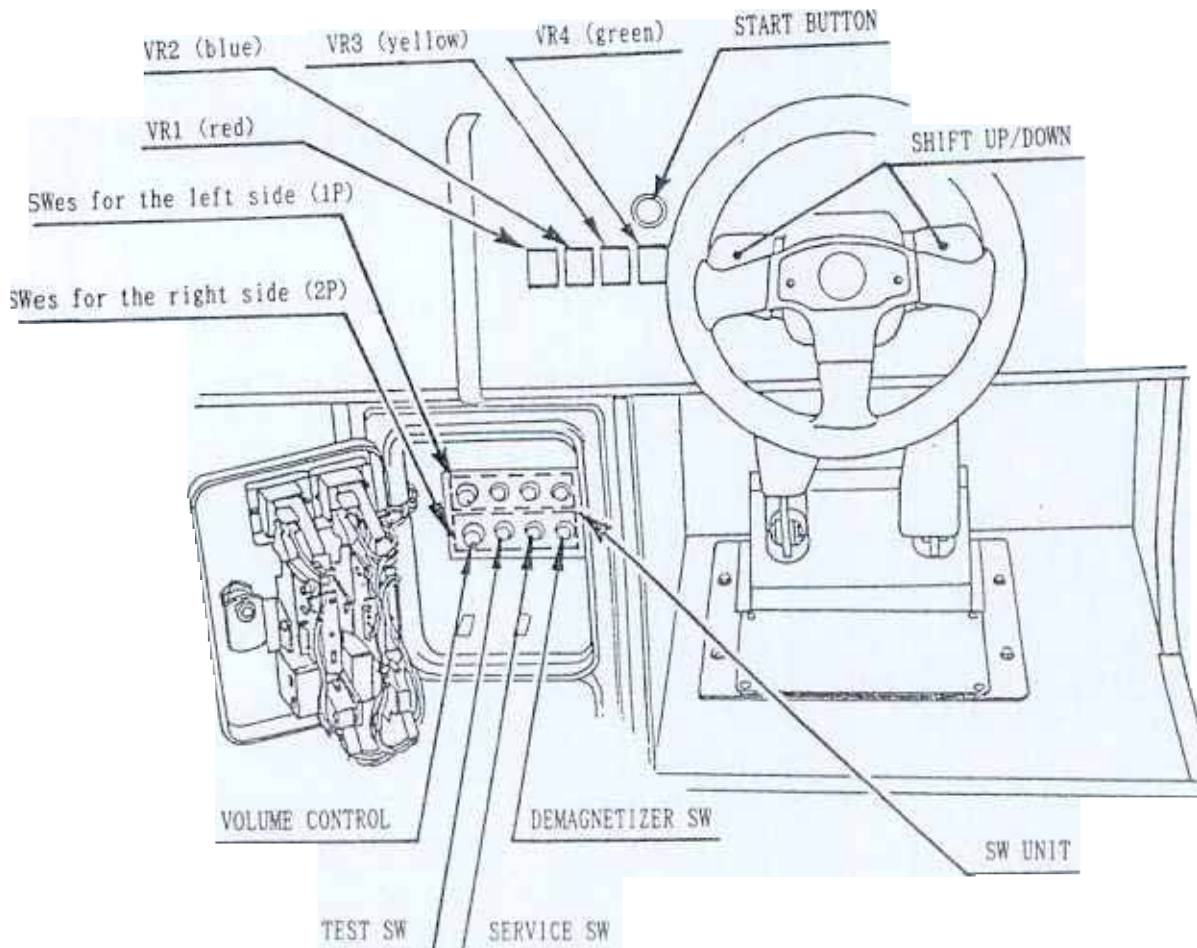



## 9. TEST MODE

### MENU MODE

Pressing the TEST SW calls up the MENU MODE SCREEN shown below. Press either the SERVICE SW or VR1 (red) and move the "\*" mark. Bring the \* mark to the desired test item and press either the TEST SW or VR4 (green) to cause the selected item's test to start.

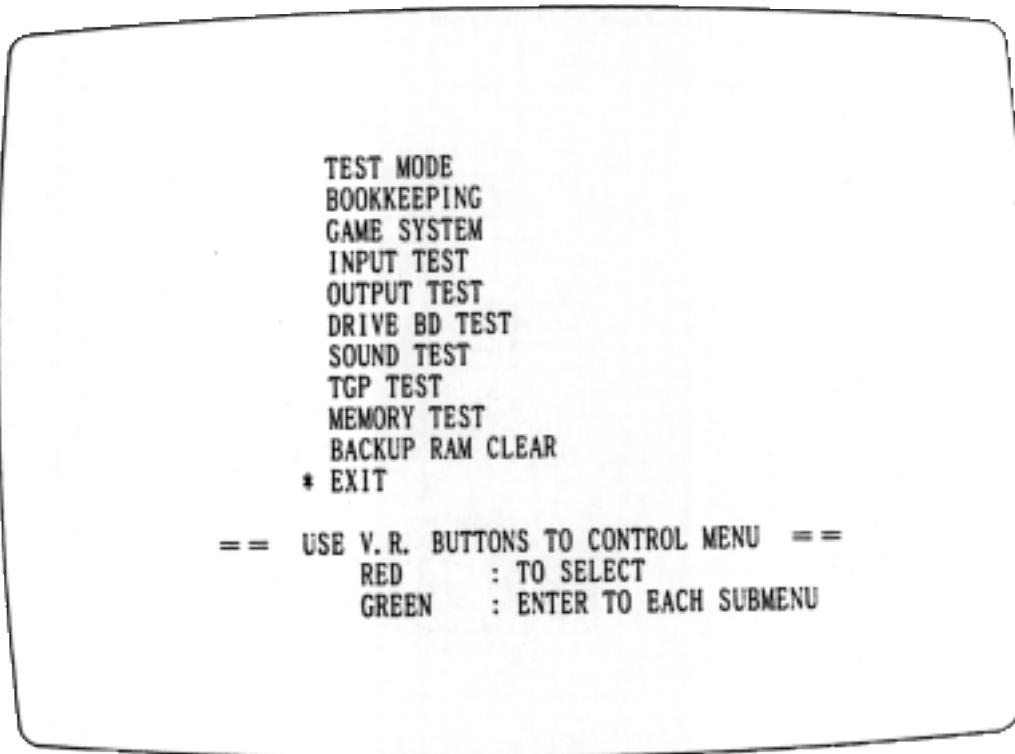

MENU MODE SCREEN

Bring the \* mark to EXIT and press the TEST SW or VR4 (green) to return to the GAME MODE.

Make sure that both the 1P and 2P sides simultaneously enter the test mode and that after finishing the test, both exit from the test mode at the same time.

This machine functions to communicate between the 1P and 2P sides and performs the NETWORK CHECK at the time the power is turned on, and exiting from the test mode. If only the 1P side or 2P side performs the NETWORK CHECK, the communications counterpart will not be found and this will not allow the 1P and 2P sides to play simultaneously.

BOOKK

me mo

he looki

ag Ti

ag

R

O:

ne

:O CHUTE

IUT

CR

mb

pu

.CE CI :D T

(um)

TOTAL T ME

Ma

me

ud

rm

me

FR

MED UM COUR

Me um

(ue)

ERT COUR:

:ou

CREDIT REPORT  
 COIN CHUTE #1           XXX  
 COIN CHUTE #2           XXX  
  
 COIN CREDITS            XXX  
 SERVICE CREDITS        XXX  
 TOTAL CREDITS           XXX

TIME REPORT  
 TOTAL TIME            xx H xx M xx S  
  
 TOTAL GAME TIME    xx H xx M xx S  
 AVERAGE GAME TIME    x M xx S  
 LONGEST GAME TIME    xx M xx S

==USE V.R. BUTTONS TO CONTROL==

RED : TO OTHER PAGE  
 GREEN : TO ESCAPE

PAGE

GAME REPORT

TOTAL PLAY GAMES    xx  
 BEGINNER COURSE    xx GAMES  
  
 AVERAGE RACE TIME  x' xx" xx  
 FASTEST RACE TIME  x' xx" xx  
  
 FASTEST BEST LAP   x' xx" xx  
  
 MEDIUM COURSE     xx GAMES  
  
 AVERAGE RACE TIME  x' xx" xx  
 FASTEST RACE TIME  x' xx" xx  
  
 FASTEST BEST LAP   x' xx" xx  
  
 EXPERT COURSE      xx GAMES  
  
 AVERAGE RACE TIME  x' xx" xx  
 FASTEST RACE TIME  x' xx" xx  
  
 FASTEST BEST LAP   x' xx" xx

==USE V.R. BUTTONS TO CONTROL==

RED : TO OTHER PAGE  
 GREEN : TO ESCAPE

PAGE

## 9-2 GAME SYSTEM

On this screen, the present game setting is displayed and also, the game setting changes can be made. Each item displays the following content:

When changing the game setting, pay attention to the following.

Although various settings are possible for the "communications" play, the following explanations refer to an independent twin type usage without linkage. For the setting as regards communications play, refer to 17. COMMUNICATIONS PLAY.

- START CREDIT : Number of credits required for starting game (1~5 credits are selected.)
- COIN SETTING : Number of coins equivalent to number of credits  
CHUTE1 : Coin setting of COIN CHUTE1  
In this page, COIN CHUTE 2 setting is displayed. However, this machine has one coin chute for each player. Therefore, disregard the COIN CHUTE 2 display.
- CAR COLOR : Color of player car  
The car colors used are RED for the 1P side and BLUE for the 2P side.
- COURSE SELECT : By changing the 1P side setting, one from among the following 4 can be selected for the course selection:  
◦ MAJORITY VOTE (if the selection by the 1P and 2P players differs, the one which is easier will be chosen.)  
◦ BEGINNER  
◦ MEDIUM  
◦ EXPERT
- LINK ID : Make sure that the 1P side is set to MASTER and the 2P side, to SLAVE.
- RACE MODE : Selects the number of race laps. The per game lap number is determined in accordance with the 1P side setting.  
◦ NORMAL (4 laps)  
◦ GRAND PRIX (20 laps)  
Normally, set to NORMAL. In the case of GRAND PRIX, the per game play time required will be in excess of 20 minutes.

```

TEST MODE
START CREDIT 1 CREDIT START
COIN SETTING 1
CHUTE1: 1COIN 1CREDIT
CHUTE2: 1COIN 1CREDIT
CAR COLOR RED
COURSE SELECT MAJORITY VOTE
LINK ID MASTER
RACE MODE NORMAL
COUNTRY U. S
MONITOR 4:3 NORMAL
CABINET 2P LINK
DIFFICULTY NORMAL
* EXIT

```

==USE V. R. BUTTONS TO CONTROL MENU ==

```

RED : TO SELECT
BLUE : CHANGE MODE
YELLOW : CHANGE MODE
GREEN : EXIT FROM THIS MENU

```

SIDE

```

TEST MODE
START CREDIT 1 CREDIT START
COIN SETTING 1
CHUTE1: 1COIN 1CREDIT
CHUTE2: 1COIN 1CREDIT
CAR COLOR BLUE
COURSE SELECT MAJORITY VOTE
LINK ID SLAVE
RACE MODE NORMAL
COUNTRY U. S
MONITOR 4:3 NORMAL
CABINET 2P LINK
DIFFICULTY NORMAL
* EXIT

```

==USE V. R. BUTTONS TO CONTROL MENU ==

```

RED : TO SELECT
BLUE : CHANGE MODE
YELLOW : CHANGE MODE
GREEN : EXIT FROM THIS MENU

```

SIDE



- COUNTRY : Message language (select U.S for the US, and EXPORT for other countries)
- MONITOR : Monitor setting (Set both monitors for 1P and 2P to 4:3 NORMAL.)
- CABINET : Type of cabinet (Set both the 1P and 2P sides to 2P LINK.)
- DIFFICULTY : Game difficulty (Select EASY, NORMAL, HARD or HARDEST. In accordance with the 1P side setting, the game difficulty is selected from among the four levels of EASY, NORMAL, HARD and HARDEST. Normally, set to "NORMAL.")
- EXIT : Returning to the menu mode

Perform the setting of CAR COLOR, LINK ID, COUNTRY, MONITOR, and CABINET in a manner as specified. If the setting is made in a manner other than specified, the game machine will not effectively function. As regards COURSE SELECT, RACE MODE and DIFFICULTY, the 2P side setting is disregarded. However, to avoid malfunctioning, set them the same as the 1P side.

※ Changing the method of the game setting

- ① In the game setting mode, press either the SERVICE SW or VR1 (red) and bring the \* mark to the desired item.
- ② Press the VR2 (blue)/VR3 (yellow) or SHIFT UP/ DOWN lever and select the desired setting item. The COIN SETTING is as shown in the table. (Refer to the next page.) COIN CHUTE 2 setting is disregarded.
- ③ To return to the menu mode, bring the \* mark to EXIT and press the TEST SW or VR4 (green). At this time, Yes or No as to the content of change is required to be determined. Use the SERVICE SW or VR1 (red) to select it.
- ④ Pressing the TEST SW or VR4 (green) causes the screen to return back to the menu mode.

Type of setting	Coin chute . 1	Coin chute 2
SETTING #1	1 COIN 1 CREDIT	1 COIN 1 CREDIT
SETTING #2	1 COIN 1 CREDIT	1 COIN 2 CREDITS
SETTING #3	1 COIN 1 CREDIT	1 COIN 3 CREDITS
	1	
	1 COIN 2 CREDITS	1 COIN 5 CREDITS
SETTING #8	1 COIN	
	1	
	2 COINS	
	1 CREDIT	1 COIN
		1
SETTING #15	1 COIN 1 CREDIT 2 COINS 3 CREDITS	1 COIN 1 CREDIT 2 COINS 3 CREDITS
SETTING #16	1 COIN 1 CREDIT 2 COINS 3 CREDITS	1 COIN 3 CREDITS
	3 COINS	
SETTING #18	1 CREDIT	4 COINS
SETTING #19	1 COIN 1 CREDIT 2 COINS 2 CREDITS 3 COINS 3 CREDITS 4 COINS 5 CREDITS	1 COIN 1 CREDIT 2 COINS 2 CREDITS 3 COINS 3 CREDITS 4 COINS 5 CREDITS
SETTING #20	1 COIN 1 CREDIT 2 COINS 2 CREDITS 3 COINS 3 CREDITS 4 COINS 5 CREDITS	1 COIN 5 CREDITS
SETTING #21	5 COINS 1 CREDIT	5 COINS 1 CREDIT
SETTING #22	3 COINS 1 CREDIT 5 COINS 2 CREDITS	1 COIN 2 CREDITS
SETTING #23	2 COINS 1 CREDIT 4 COINS 2 CREDITS 5 COINS 3 CREDITS	2 COINS 1 CREDIT 4 COINS 2 CREDITS 5 COINS 3 CREDITS
SETTING #24	2 COINS 1 CREDIT 4 COINS 2 CREDITS 5 COINS 3 CREDITS	1 COIN 3 CREDITS
SETTING #25	INS 1 CRE INS 2 CRE INS 3 CRE INS 4 CRE INS 6 CRE	1 COIN 1 CRED 2 COINS 2 CRED 3 COINS 3 CRED 4 COINS 4 CRED 5 COINS 6 CRED...
	1 COIN 2 COINS 3 COINS 4 COINS 5 COINS	1 COIN 6 CREDITS
SETTING #27	FREE PLAY	FREE PLAY

### 9-3 INPUT TEST

In this test, each input device test is performed.

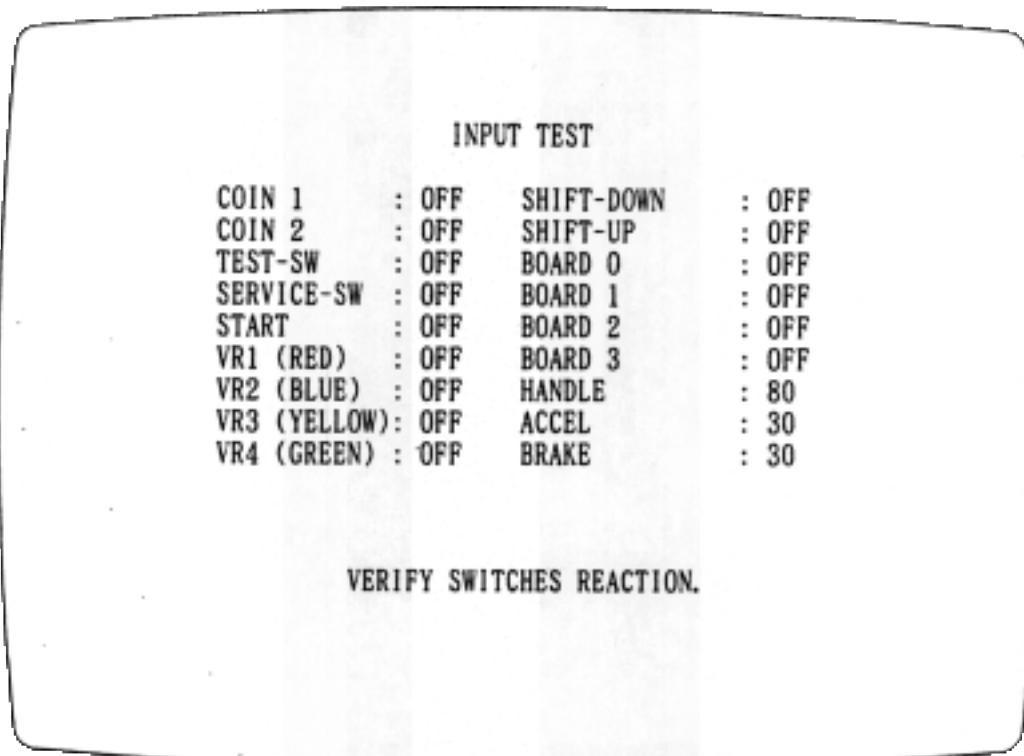

The SW system allows, when each SW is pressed (SHIFT DOWN/UP is to be pushed towards you), the display to indicate ON. The V.R. system allows the present V.R. value to be displayed. The following shows the correct values :

HANDLE : Under 2DH ← · 7DH ~ 83H → Over D3H  
(Centering position)

ACCEL Under 30H → Over CDH

BRAKE Under 30H · Over A7H  
(Pedal OFF) (Pedal ON)

Pressing the TEST SW or the VR4 (green) causes the screen to return back to the menu mode.

The four SWes (BOARD 0~3) on the I/O BOARD are normally not used.

OUT PUT

Th comp 3 age and ow ng

On TEST SW VR  
en ha he ne, mod

CRT BE TEST C ha  
Th page chec he mon

CRT NO OR TEST  
Th page ad ng he mo co

AMP TEST  
Th ge check amp

9-5 DRIVE BD TEST (HANDLE TEST)

This PAGE allows the handle mecha's V.R., motor, clutch, etc., to be checked. Pressing the TEST SW causes the MENU mode to return back to the screen. Note that pressing VR4 (green) will not allow it to return.

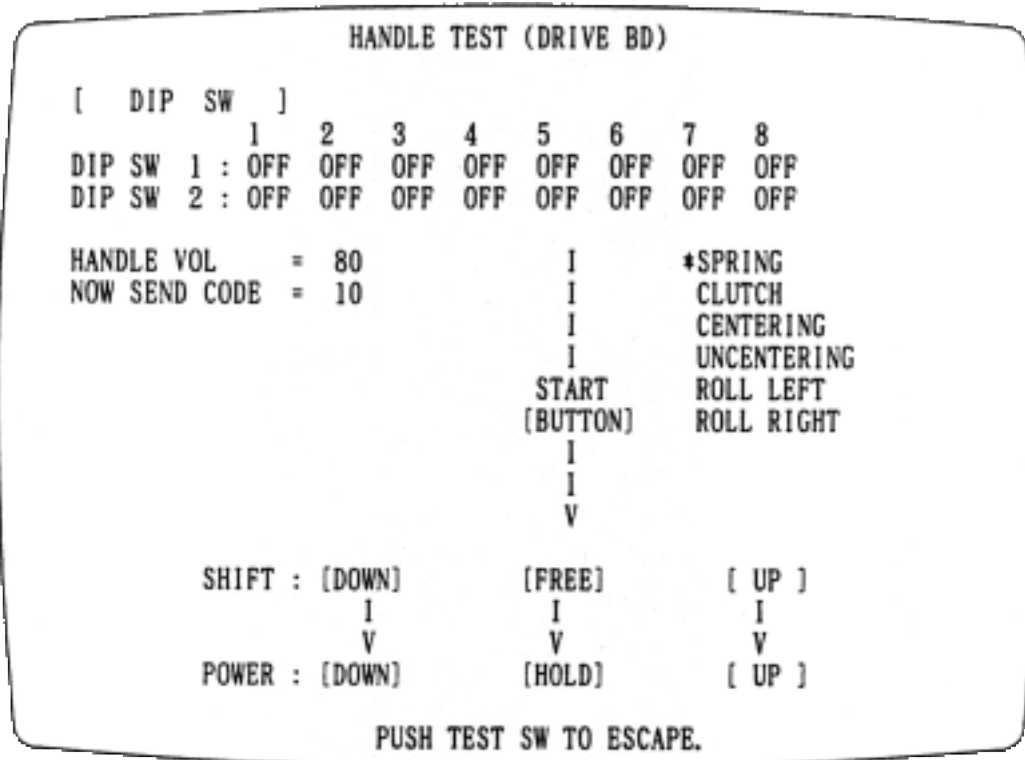

[DIP SW]

DIP SW status table : Displays the status of the DIP SW on the DRIVE BD.

HANDLE VOL : Refers to the handle V.R. value.

NOW SEND CODE : The setting code selected by using the START BUTTON.

SPRING : The setting in which the motor and clutch will not be operated.

CLUTCH : The setting in which the clutch is operated.

CENTERING : The setting in which the motor and clutch are operated so as to allow for handle centering.

UNCENTERING : The setting in which the motor and clutch are operated so as not to allow for handle centering.

ROLL LEFT : The setting in which the motor and clutch are operated so as to cause the handle to turn left.

ROLL RIGHT : The setting in which the motor and clutch are operated so as to cause the handle to turn right.

Press the START BUTTON to move the \*cursor and select the applicable motor & clutch operation setting. Ascertain that the steering wheel moves in accordance with the selected setting. In the case where "SPRING" is selected, the handle centering is performed merely by the force of the HANDLE MECHA interior's SPRING mechanism. Also, controlling the revolution torque subjected to the handle by the motor is performed by the clutch. Operating the SHIFT UP increases the revolution torque and operating SHIFT DOWN decreases it. In the status where the setting in which the motor is operated, ascertain the revolution torque changes by holding the handle by hand and operating SHIFT UP as well as SHIFT DOWN.

DIP SW SETTING

By using the DIP SW on the DRIVE BD., set the handle weight via "feeling" and select ON or OFF of POWER ON CHECK. DIP SW 1 controls the 1P side and DIP SW 2, the 2P side.

COMMON SETTING FOR DIP SW 1 & DIP SW 2

Handle weight( "feeling" )setting			
1	2	3	Function
* OFF	OFF	OFF	Light ↑ Handle weight "feeling" ↓ Heavy
ON	OFF	OFF	
OFF	ON	OFF	
ON	ON	OFF	
OFF	OFF	ON	
ON	OFF	ON	
ON	ON	ON	
POWER ON CHECK			
4	Function		
* OFF	performed		
ON	not performed		
Not used			
5	6	Function	
* OFF	OFF	Not used (always OFF)	

SETTING THE OPERATION & DISPLAY MODE

Operation mode setting		
DIP SW 1		
7	8	Function
* OFF	OFF	Always OFF
On-BD 7SEG.LED display		
DIP SW 2		
7	8	Function
* OFF	OFF	Displays the handle V.R. value (00~80~FF)
ON	OFF	Signal value presently given to the clutch
OFF	ON	Data from the I/O BD. (00~FF)
ON	ON	Data to the I/O BD. (00~FF)

Note The \* mark refers to the setting at the time of shipment.

When DIP SW setting changes are made, be sure to turn the power off and then back on again. The new setting is not effective unless the power is turned back on again.

Due to the handle mecha's secular change, the handle weight (via "feeling" ) may somewhat vary. For example, the 1P side handle may become lighter than the 2P side handle. In such a case, change the DIP SW setting for handle weight to obtain an appropriate weight.



The DRIVE BD. will appear when the 2P side CONTROL PANEL (HANDLE MECHA) or the BACKBOARD is removed. The on-BD 7-SEG. display normally indicates, as shown in the above table, the handle V.R. value or data to and from the I/O BD.

DRIVE BD ERROR DISPLAY

When malfunctioning occurs in the DRIVE BD., testing will not be performed even if the DRIVE BD. TEST is selected in the menu mode. In this case, the ERROR number will be displayed by the 7-SEG. display on the DRIVE BD. (when the status is satisfactory, the handle's V.R. value is displayed in the decimal numeration system). Also, when a POWER-ON CHECK ERROR occurs, the 7-SEG. display data repeatedly flashes. First check the handle mecha's V.R., the motor, clutch, etc.

#### SOUND TEST

In this test, operate the following switches to determine the selection and hear the sound. This test is comprised of 3 pages, each performing a different sound test.

PAGE 1 : MUSIC TEST

BGM during game is played.

PAGE 2 : VOICE TEST

Announcement and comment voices during game play are emitted.

PAGE 3 : EFFECTS TEST

Sound effects during game play are emitted.

START BUTTON : Check the sound just selected.

SHIFT UP/DOWN : Select the desired item.

VR2 (blue)/VR3 (yellow)

SERVICE SW, VR1 (red) : Proceed to the next page.

TEST SW, VR4 (green) : Return to the menu mode.

#### TGP TEST

In this test, the TGP (the on-screen display related IC) is checked. "GOOD" is displayed for normal ICs and "BAD" is displayed for abnormal ICs.

Press the TEST SW or VR4 (green) to return to the menu mode.

#### 9-8 MEMORY TEST

This test is for checking the memory IC operations on the board.

"GOOD" is displayed for normal ICs and "BAD" is displayed for abnormal ICs.

In this test, irregular status will be seen on the screen for the time being. However, this is a part of the testing and continues approx. one minute.

Pressing the TEST SW or VR4 (green) causes the menu mode to return on to the screen.

#### 9-9 BACKUP RAM CLEAR

This page is for erasing the contents of BOOKKEEPING. To erase the contents of BOOKKEEPING, bring the \* mark to "YES" and press the TEST SW or VR4 (green).

After the contents of BOOKKEEPING are erased, "COMPLETED" appears on the screen. The menu mode returns back to the screen.

Also, note that the game setting contents are not affected by BACKUP RAM CLEAR operation.

## 10. ACCEL & BRAKE (ACCELERATOR & BRAKE)

Check the V.R. value in the test mode (9-3 INPUT TEST).

The appropriate value of each V.R. is as follows :

	OFF	ON
V.R. for ACCELERATOR :	Under 30H .....	Over CDH
V.R. for BRAKE :	Under 30H .....	Over A7H

### 10-1 REMOVING THE ACCEL & BRAKE

- ① Remove the 4 hexagon bolts (black) which secure the ACCEL & BRAKE.
- ② Lift up the ACCEL & BRAKE.
- ③ Disconnect the two connectors, and remove the ACCEL & BRAKE.

Adjust the V.R. while the connectors are in their connected state, by watching the V.R. value shown on the monitor.

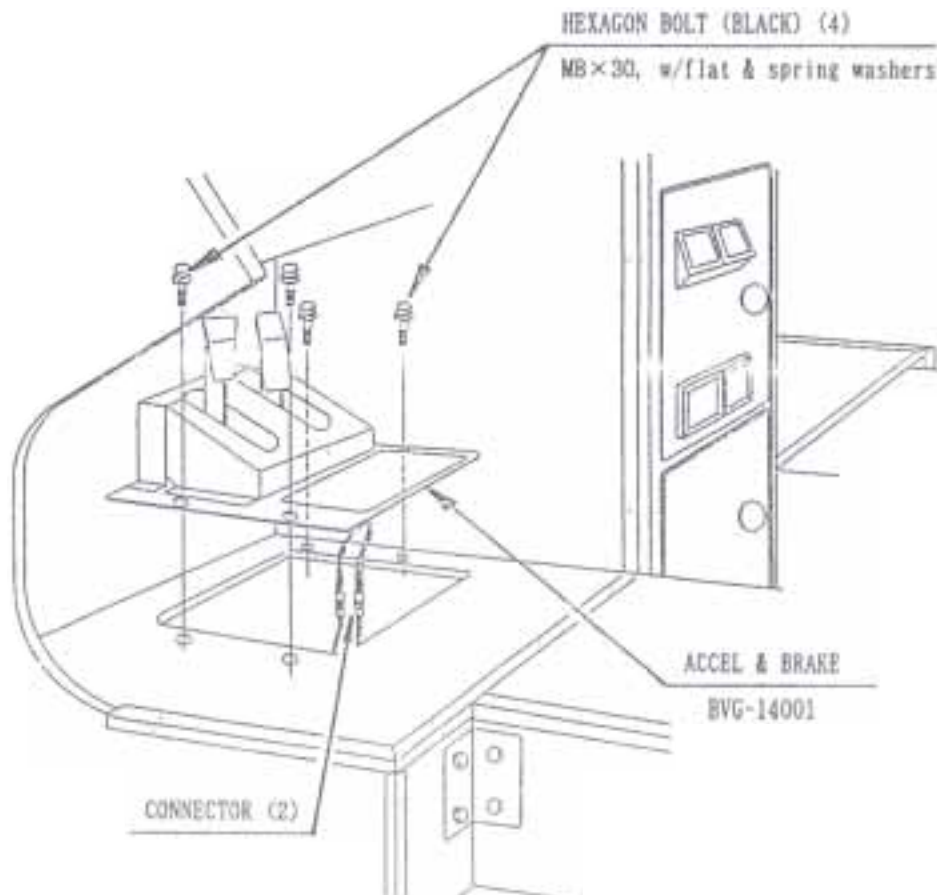

## 2 REPLACING AND ADJUSTING THE V. R. FOR THE ACCEL & BRAKE

The following procedure applies to both the accelerator and brake.

After taking off the connector from the V. R. to be replaced

(accelerator : 3P red, brake : 3P blue), take out the 2 screws which secure the VR bracket, and remove the V. R. together with the bracket.

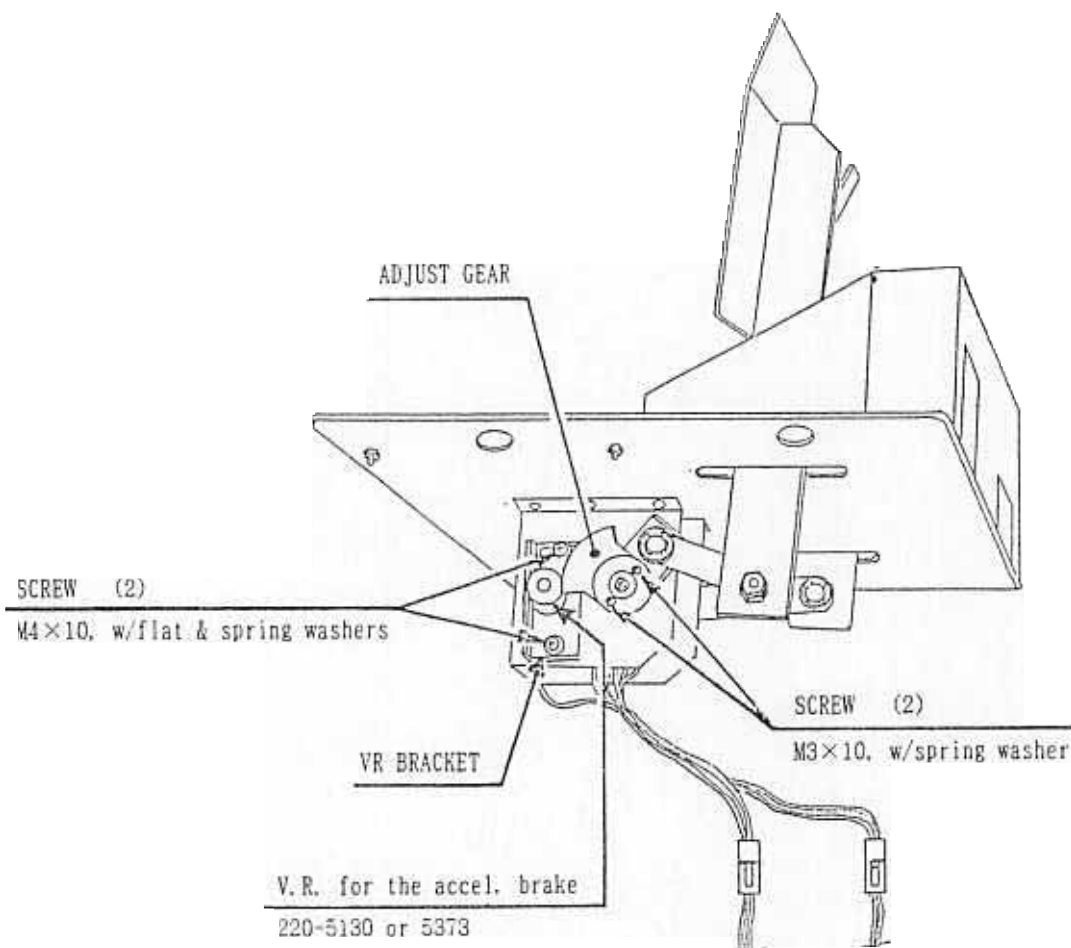

### ADJUSTMENT PROCEDURE

When making the V. R. adjustments, before causing the gears to be engaged, first make sure that the V. R. value is approx. 30H and secure the VR BRACKET. At this time, make sure that the appropriate backlash is obtained.

After securing the V. R., check to see that the V. R. value is within the above mentioned appropriate value range, by stepping on the pedal and releasing it. If the value is not within the range, make adjustment by loosening the 2 screws which secure the ADJUST GEAR.

### 10-3 GREASING

Grease the gears and bearings once every three months.

# 11 HANDLE (CONTROL PAN

MONITOR ADJUSTMENT KNOB

AMPERPROOF SCREW

MG 30, using flat washer

GLASS HOLDER  
BVG-1009

CONTROL PANEL TWIN

MONITOR ADJUSTMENT KNOB

HEXAGON BOLT (BLACK) (2)

MB 30

WB

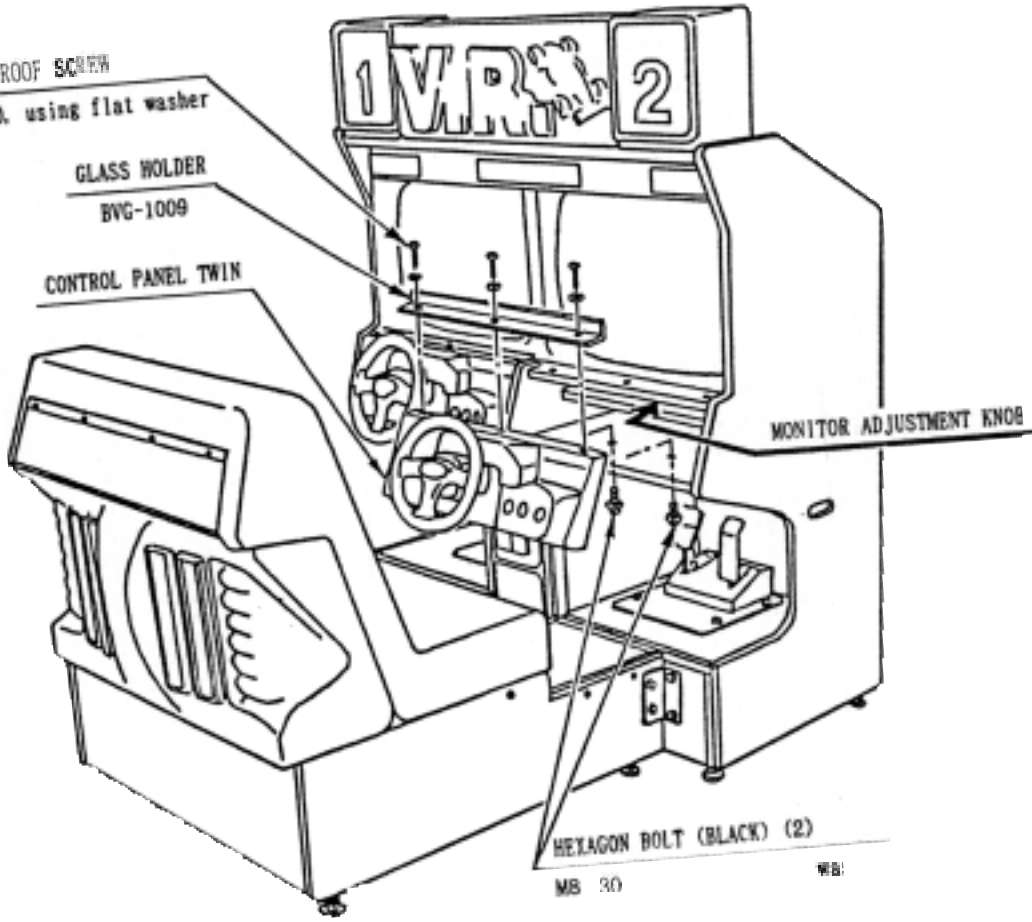

©

bo

PAO

DER

MO

ME

ME

-2 REPLACING AND ADJUSTING THE HANDLE'S (STEERING WHEEL'S) V.R.

The upper side V.R. of the HANDLE MECHA is for the GAME BD., and the lower side one, for the DRIVE BD. Check the value of the V.R. for the GAME BD., by watching the INPUT TEST screen in the test mode; and check the value of the V.R. for the DRIVE BD., by watching the HANDLE TEST (DRIVE BD TEST) in the test mode.

The appropriate value of each V.R. is as follows:

When the steering wheel is turned to or positioned at	:	Left	Center	Right
V.R. for the GAME BD.	:	Under 2DH	← 7DH ~ 83H →	Over D3H
V.R. for the DRIVE BD.	:	Under 2DH	← 7DH ~ 83H →	Over D3H

To replace the V.R., after taking off the connector from the V.R. to be replaced, take out the 2 screws which secure the VR BRACKET, and remove the V.R. together with the bracket and gear.

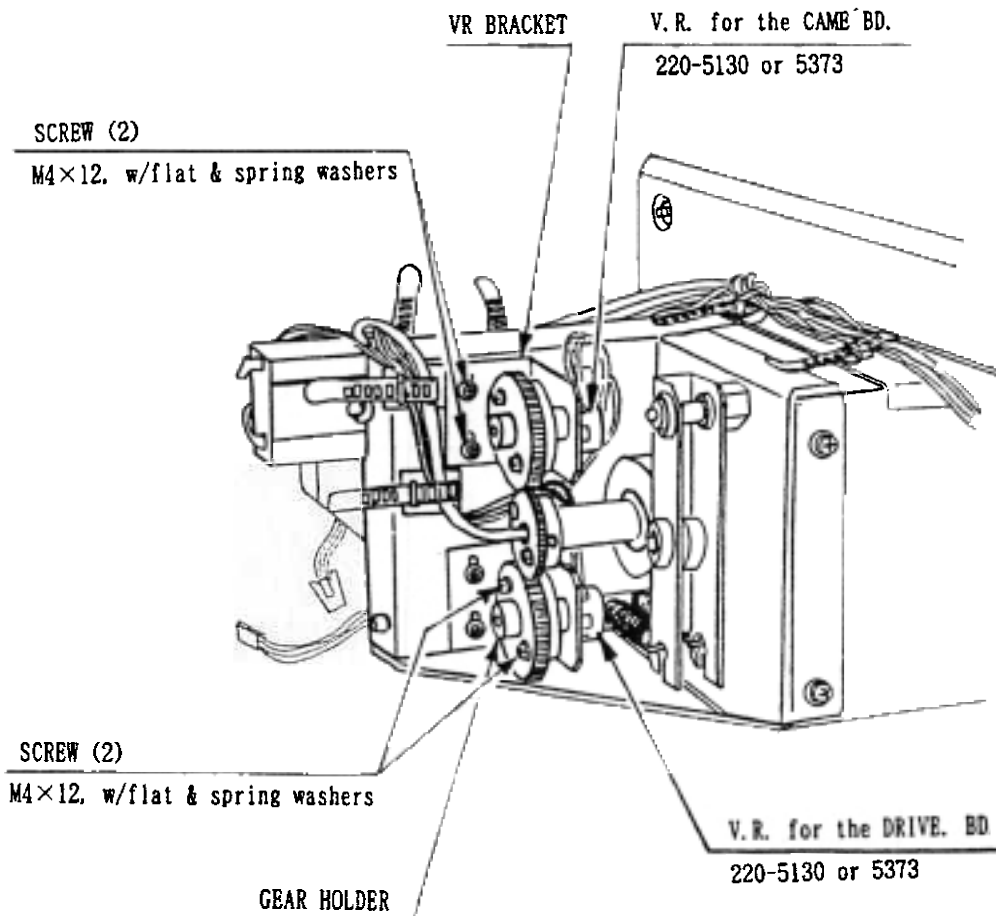



#### Method of V.R. adjustment

- ① Loosen the 2 screws which secure the VR BRACKET, move the VR BRACKET and detach the gears.
- ② Adjust the V.R. so that it is consistent with the value near the center.
- ③ Cause the gears to be engaged and secure the VR BRACKET. At this time, make sure that an appropriate backlash is obtained.
- ④ If the V.R. value exceeds the allowable value when the steering wheel is at the center, loosen the 2 screws, and turn the gear holder to adjust the V.R. value so that it is within the above allowable range.

#### 11-3 GREASING

Grease the gears and bearings once every three months.

THIS PAGE INTENTIONALLY OMITTED

THIS PAGE INTENTIONALLY OMITTED

#### 4. REPLACEMENT OF FLUORESCENT LAMP, AND LAMPS

In a manner as shown below, remove the parts and replace the fluorescent lamp and lamps.

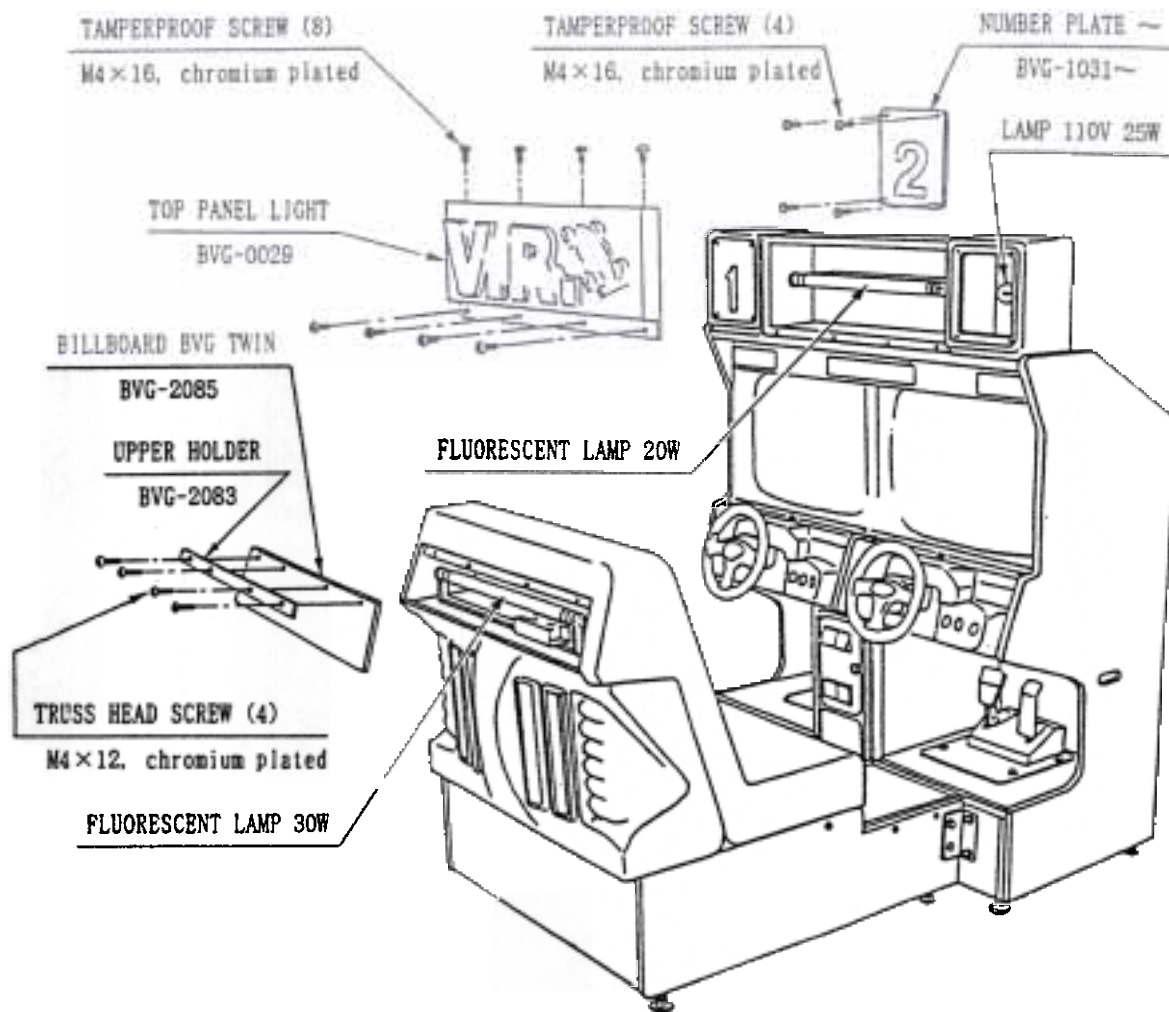

#### 15. PERIODIC CHECK

The items listed below require periodic check and maintenance to retain the performance of this machine.

	Item	Interval	Reference
CONTROL DEVICE	Check of adjust gear engagement	Trimonthly	10-2, 11-2
	Greasing of adjust gear and bearing	Trimonthly	10-3, 11-3
FRONT CABINET	Fan motor brush replacement	Biannually	13

## 16. DESIGN RELATED PARTS

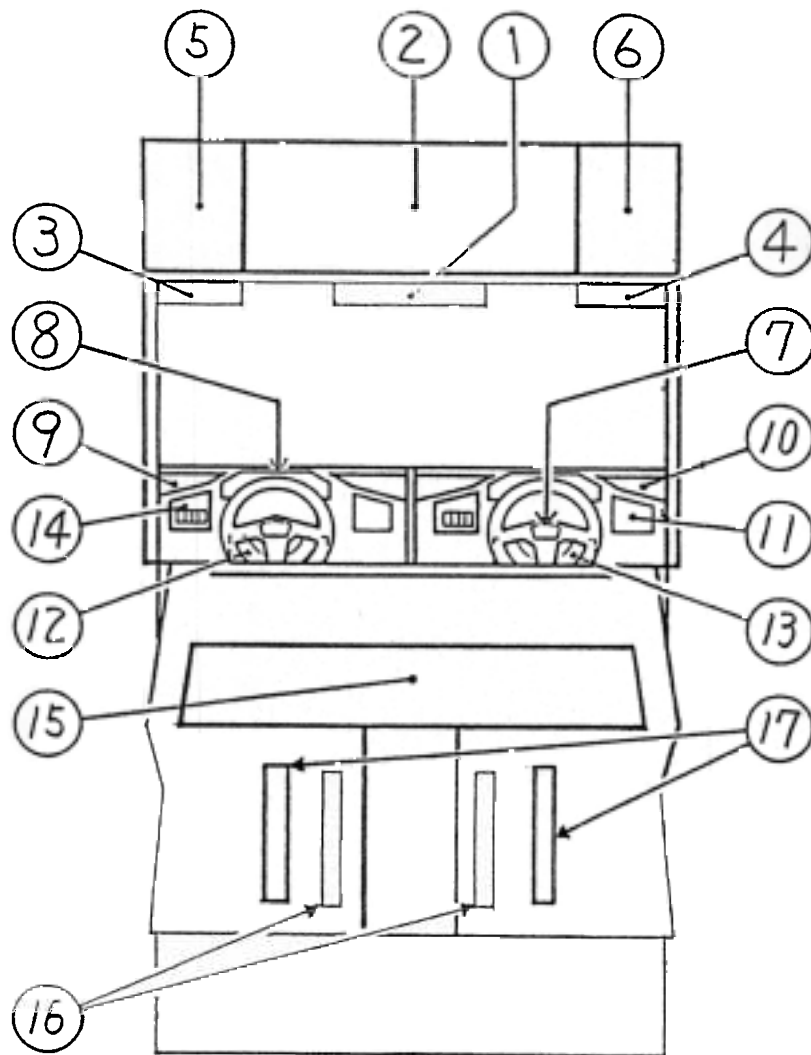

No.	PART NO.	DESCRIPTION	No.	PART NO.	DESCRIPTION
1	422-0426-01	PLAY INSTR SH V. R. TWIN ENG	10	BVG-1356-D	STICKER SILVER R
2	BVG-0029	ASSY TOP PANEL LIGHT	11	BVG-1356-E	SW DESIGN SHEET
3	BVG-1017	STICKER FRONT GLASS NO. 1	12	BVG-1356-F	STICKER LOWER L
4	BVG-1018	STICKER FRONT GLASS NO. 2	13	BVG-1356-G	STICKER LOWER R
5	BVG-1031-01	NUMBER PLATE NO. 1	14	BVG-1358	SW PLATE ENG
6	BVG-1031-02	NUMBER PLATE NO. 2		BVG-1359	SW PLATE MARS (FOR MARS COIN CHUTE)
7	BVG-1212	STEERING EMBLEM BVG	15	BVG-2085	BILLBOARD BVG TWIN
8	BVG-1356-B	METER PANEL	16	BVG-2091	STICKER T-WIN
9	BVG-1356-C	STICKER SILVER L	17	BVG-2092	STICKER V12

## COMMUNICATIONS (LINK) PLAY

This machine allows for connection with not only another TWIN type, but also with the DX type or U/R type, permitting up to 8 players to simultaneously play. Herein, the installation method of the TWIN TYPE "communications" play is explained.

### 17-1 INSTALLATION PRECAUTIONS

- 1) When linking a number of machines, be sure to supply sufficient power for the corresponding number of machines. The per unit standard voltage/amperage is 100 ~120V/10A and 200~240V/5A.
- 2) Due to the length of the communications cable, the distance in between the machines will be approximately 1.2 meters or less.

### 17-2 COMMUNICATIONS CABLE CONNECTION

In this machine, the two communications cables are connected in between the GAME BDs. to allow communications to be made between the two game BDs. (Fig. 1). Change the cable connection to the one applicable for multiple machine connections (Fig. 2 & Fig. 3).

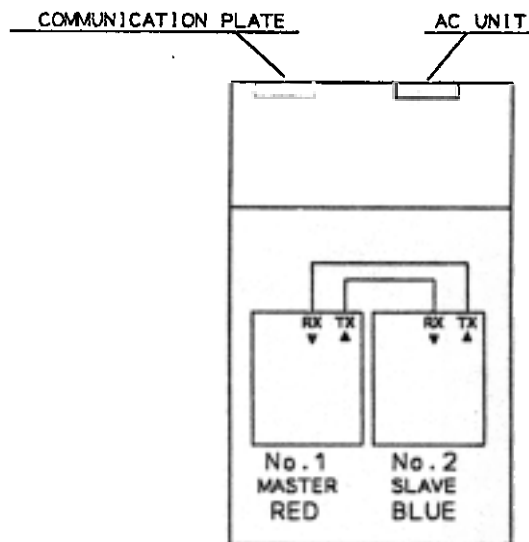

TWIN (1) 2P LINK SYSTEM

2P LINK SYSTEM

Fig. 1



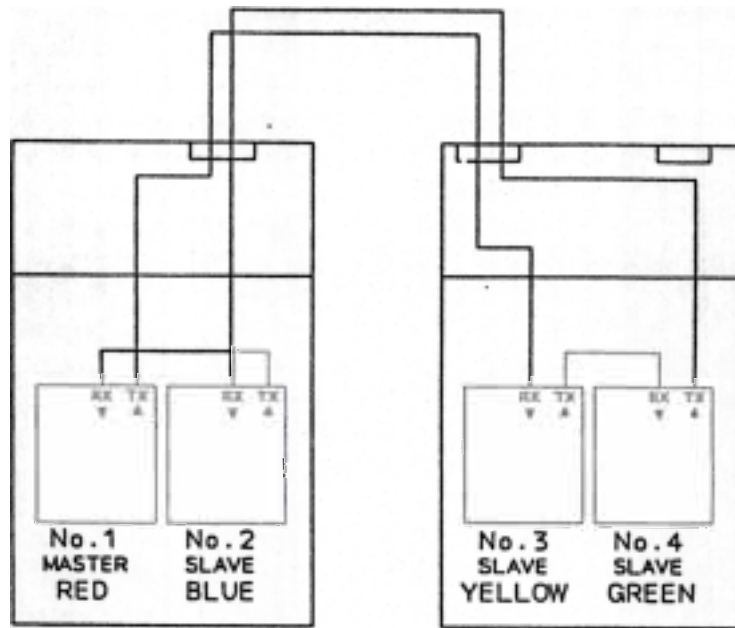

TWIN (2) 4P LINK SYSTEM

4P LINK SYSTEM

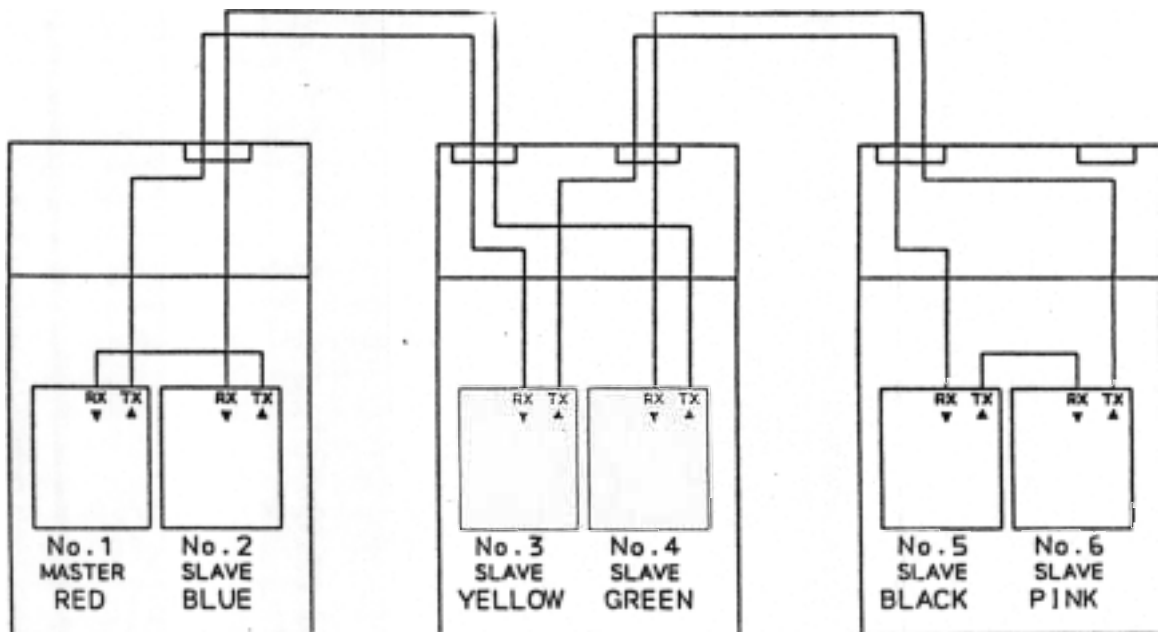

TWIN (3) 6P LINK SYSTEM

6P LINK SYSTEM

Fig. 2

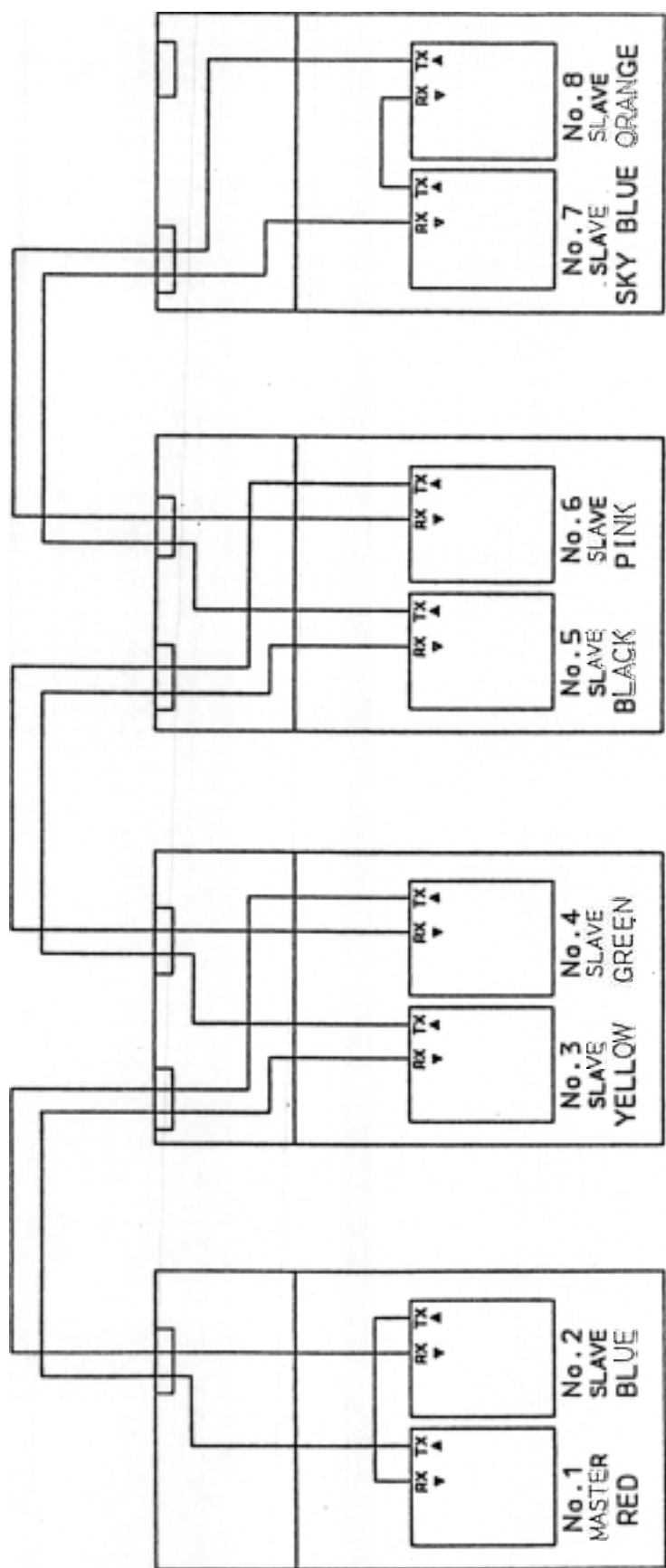

TW1 8P NK SYSTEM

P L N K Y T M

Take the hexagon and unlock the locks that cabinet seat by decines backward  
 Take off the screws cause the wooden board which the mounted open (Photo

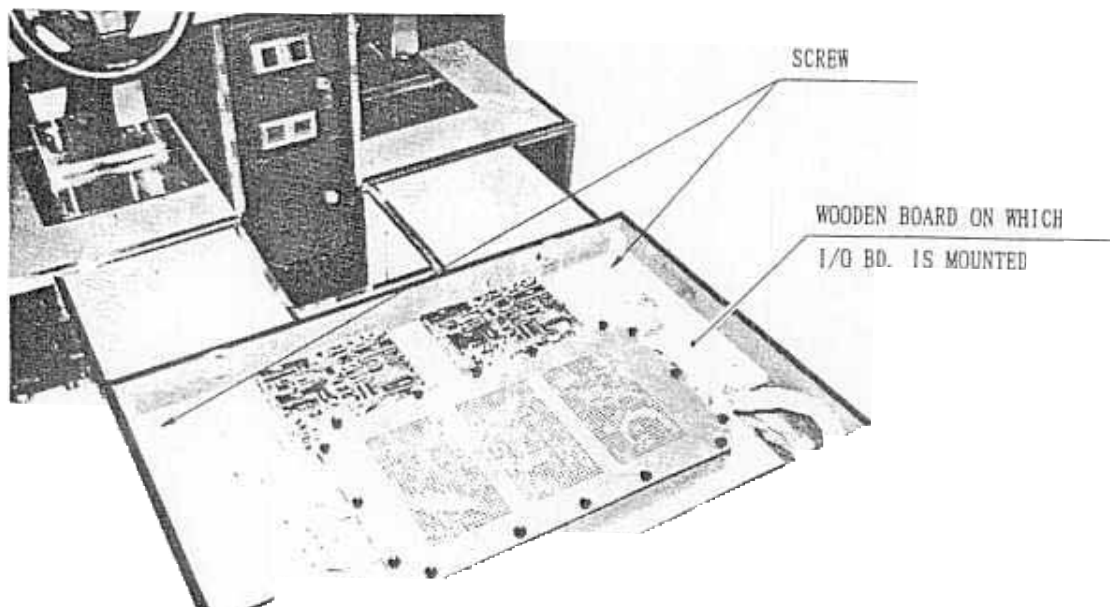

Photo

The two shield cases, each containing GAME the REAR CABINET bottom board. Remove fr the shield cases (Photo

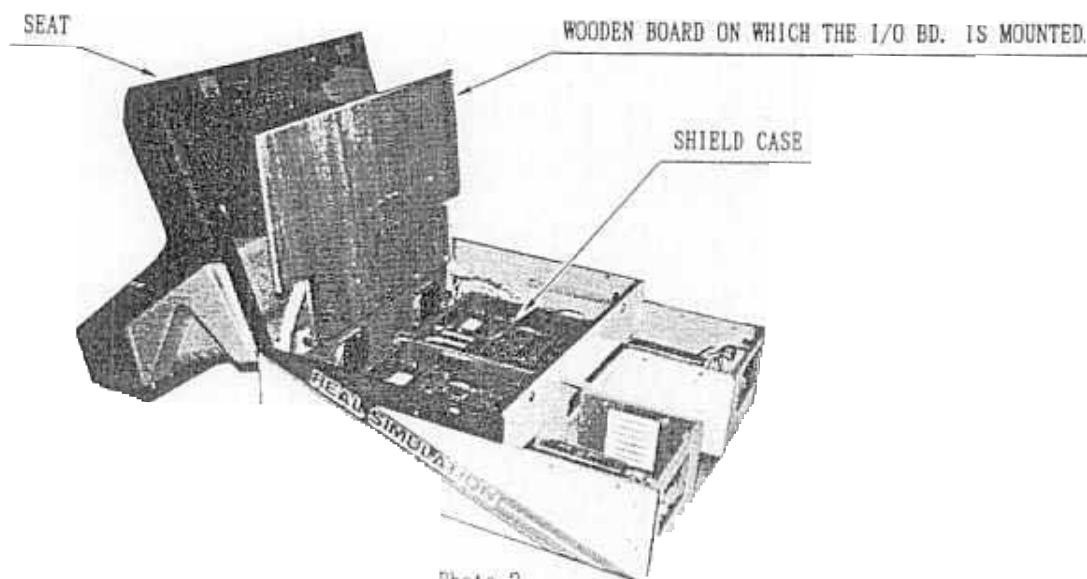

Photo

- 4) For the purpose of connections with other units, long communications cables are utilized. By referring to Fig. 2 and Fig. 3, remove the applicable communications cable from the GAME BD. (such as the No. 2 seat GAME BD.'s TX connector, etc.) (Photo 3).

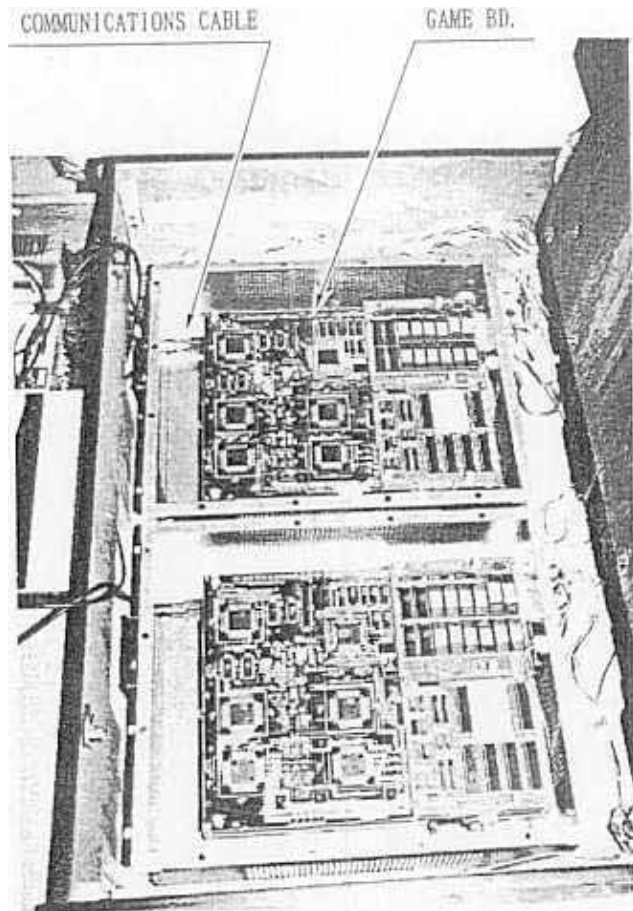

Photo 3

- 5) Pull out the communications cable to be connected with another unit, via the AC UNIT or COMMUNICATION PLATE on the back of the FRONT CABINET. Remove the maintenance lids & the backboard, and bring the communications cable to the AC UNIT and or COMMUNICATION PLATE.

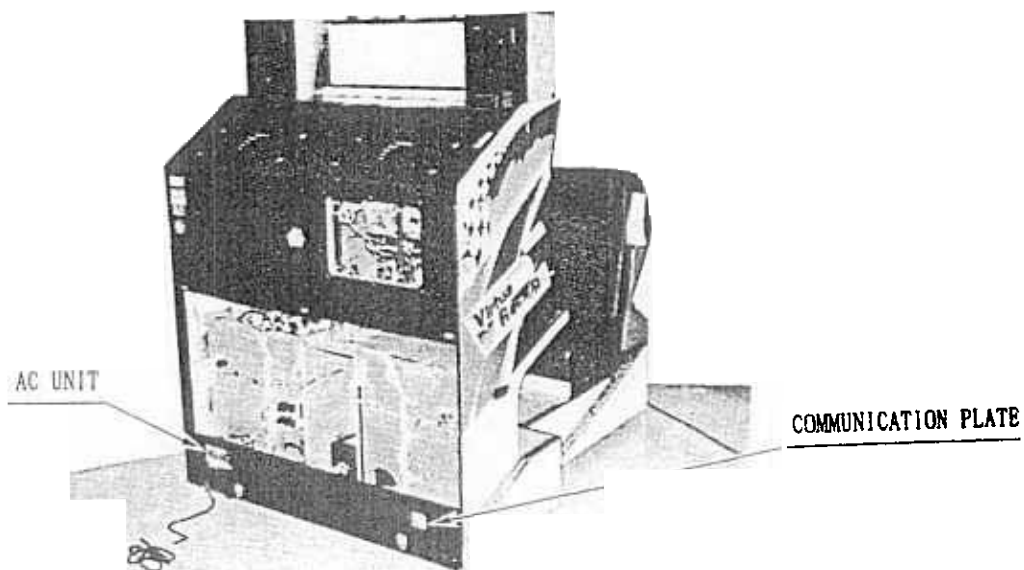
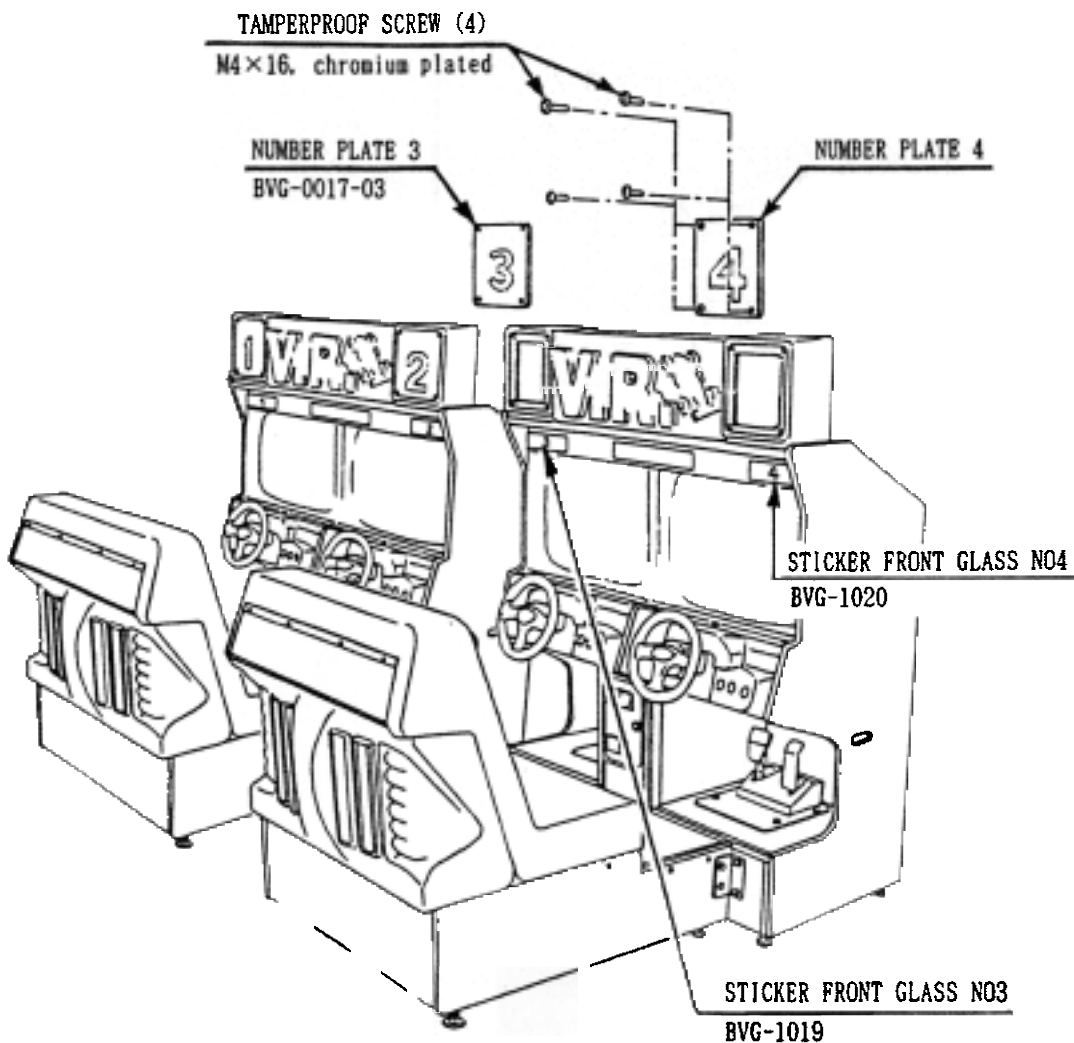

Photo 4

- 6) Bring the communications cables into the other unit's cabinet from the AC UNIT and or COMMUNICATION PLATE and connect them to the applicable GAME BD.
- 7) By using the cord clamps, secure the communications cables so that they will not bend at a right angle.
- 8) Reinstall the parts to their original state.

### 17-3 REPLACEMENT OF NO. PLATES & STICKERS

Replace the No. plates and stickers in a manner so that they will line up in the sequential order of No. 1, No. 2, No. 3 and so on starting from the left side of the unit which was connected to the other unit(s).



#### 7-4 SETTING FOR COMMUNICATIONS PLAY

Cause all of the machines to enter the test mode and change the game setting for each seat in a manner so as to meet the communications play. When changing the setting, refer to the procedure mentioned in 9-2 GAME SYSTEM. CAR COLOR and LINK ID are the two items for which the setting changes are to be made. The setting of COURSE SELECT, RACE MODE, and DIFFICULTY is programmed in a manner so as to follow the setting of the No. 1 seat (LINK ID is set to MASTER). However, in order to avoid malfunctioning, make sure that the same setting is made for all of the seats.

SETTING TABLE

Seat No.	NO. 1	NO. 2	NO. 3	NO. 4	NO. 5	NO. 6	NO. 7	NO. 8
CAR COLOR	RED	BLUE	YELLOW	GREEN	BLACK	PINK	SKYBLUE	ORANGE
LINK ID	MASTER	SLAVE	SLAVE	SLAVE	SLAVE	SLAVE	SLAVE	SLAVE

At the time of communications play, by setting the car color, the seat No. is determined. Therefore, set the CAR COLOR in a manner consistent with the seat No..

For the LINK ID, one car is to be designated as MASTER and the rest of the cars to be SLAVE. If two or more cars are set to MASTER, the communications play can not be performed.

Normally, set the No. 1 seat (RED) to MASTER.

In the case where the LINK ID of the No. 1 seat is set to MASTER, and the COURSE SELECT is set to MAJORITY VOTE, the course selection is determined by majority selection. If the number is even as in 2 versus 2, the easiest one will be chosen.

W/IT OI TO W TH IST MOI  
Th ma ETWO  
IC ime po wh mo  
The ommin ma  
mu on  
ma (TWO) CHEC  
h ma h  
wh he Wh ma h  
mod me om he  
o. W/ he SW h DR VE



# PARTS LIST

OP ASSY V RTUA RAC NG TW

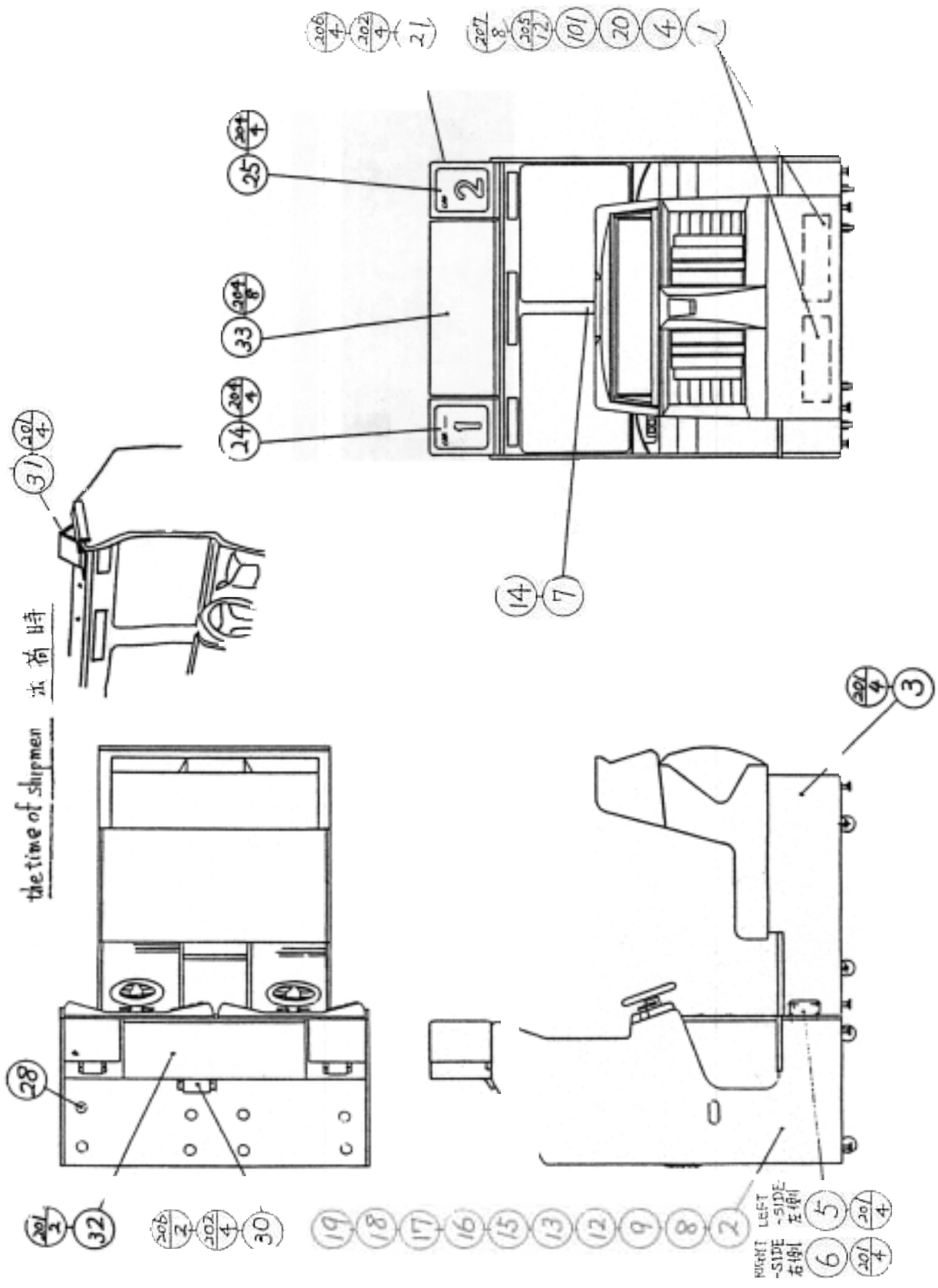

## ① TOP ASSY VIRTUA RACING TWIN

(D-2/4)

ITEM NO.	PART NO.	DESCRIPTION	NOTE
1	BVG-0015	ASSY SHIELD CASE TWIN	
2	BVG-10001	ASSY FRONT CABINET	
3	BVG-20001	ASSY REAR CABINET	
4	833-8942	GAME BD VIRTUA RACING TWIN	
5	BVG-0009	JOINT BRKT L	
6	BVG-0010	JOINT BRKT R	
7	421-5800-191	ORIGINAL SEAL VIRTUA RACING	
8	421-6594	STICKER SERIAL NO INFO	
16	421-7987	STICKER ELEC SPEC	
17	421-7988	STICKER SERIAL NUMBER	
18	SGM-4111	KEY BAG	
19	421-6709	STICKER, SERVICE INSTR ENG	
20	421-7515	STICKER FIBER CABLE TX/RX	
21	BVG-0100	ASSY NUMBER BOX	
24	BVG-0017-01	NUMBER PLATE 1	
25	BVG-0017-02	NUMBER PLATE 2	
28	BVG-0027	HOLE PLATE	
29	SGM-4040	POLYETHYLEN COVER 950×1350×1800	
30	BVG-0032	WIRE COVER	
31	BVG-0033	SHIPPING BRKT S	
32	BVG-0150	ASSY BILLBOARD	
33	BVG-0029	TOP PANEL LIGHT	
101	600-6047-07	ASSY FIBER CABLE 07 MB	

## ① TOP ASSY VIRTUA RACING TWIN

(D-3/4)

ITEM NO.	PART NO.	DESCRIPTION	NOTE
201	039-0125	HEX BLT BLK W/FS M8×35	
202	008-0416	TMP PRF SCR TH M4×16	
203	090-0024	SCOCH ELEC TAPE UL10 19mm×55M	
204	029-0169	TMP PRF SCR TH CHROME M4×16	
205	029-0024	S-TITE SCR FH M3×8	
206	069-0119	FLT WSHR BLK 4.4-10×1.6	
207	000-0416-FS	M SCR PH W/FS M4×16	
401	601-6604-70	CARTON BOX 70	
402	SGM-2675	POLYETHYLENE BAG 240×370	
403	420-6056-02	OWNERS MANUAL VIRTUA RACING TWIN ENG	
404	421-8230-01	ADJUST INSTR SH BVG ENG	
405	420-5962	DSPL MANUAL 26" 200-5187 ENG	
	420-5963	DSPL MANUAL 26" 200-5195 ENG	
406	540-0006-01	WRENCH FOR TAMP PRF SCR DUAL TYPE M4	
407	540-0007-01	WRENCH FOR TAMP PRF SCR DUAL TYPE M5	
408	220-5130	VOL CONT B-5K OHM	
409	BVG-1019	STICKER FRONT GLASS N03	
410	BVG-1020	STICKER FRONT GLASS N04	
411	BVG-1021	STICKER FRONT GLASS N05	
412	BVG-1022	STICKER FRONT GLASS N06	
413	BVG-1023	STICKER FRONT GLASS N07	
414	BVG-1024	STICKER FRONT GLASS N08	
415	BVG-0017-03	NUMBER PLATE 3	
416	BVG-0017-04	NUMBER PLATE 4	
417	BVG-0017-05	NUMBER PLATE 5	

① TOP ASSY VIRTUA RACING TWIN

(D-4/4)

ITEM NO.	PART NO.	DESCRIPTION	NOTE
418	BVG-0017-06	NUMBER PLATE 6	
419	BVG-0017-07	NUMBER PLATE 7	
420	BVG-0017-08	NUMBER PLATE 8	
421	540-0015-01	WRENCH FOR TAMP PRF SCR DUAL TYPE M6	
422	514-5036-10000	FUSE $\phi 6.4 \times 30$ 10000mA 125V	AC100~120V AREA
	514-5037-7000	FUSE $\phi 6.4 \times 30$ 7000mA 250V	AC220~240V AREA
423	390-5412	LAMP 110V 25W (TOZAI S35 E17C)	
424	INST NO. 587-01	INSTALLATION INSTR VIRTUA RACING TWIN ENG	
	BVG-0026	SHIPPING BRKT	
	000-0525-FS	M SCR PH W/FS M5 $\times$ 25	
	421-6119-91	STICKER FCC	USA
	421-6120	STICKER SEGA USA	USA
	1092-1	SEGA VIRTUA RACING TWIN	

② ASSY SHIELD CASE TWIN (BVG-0015)

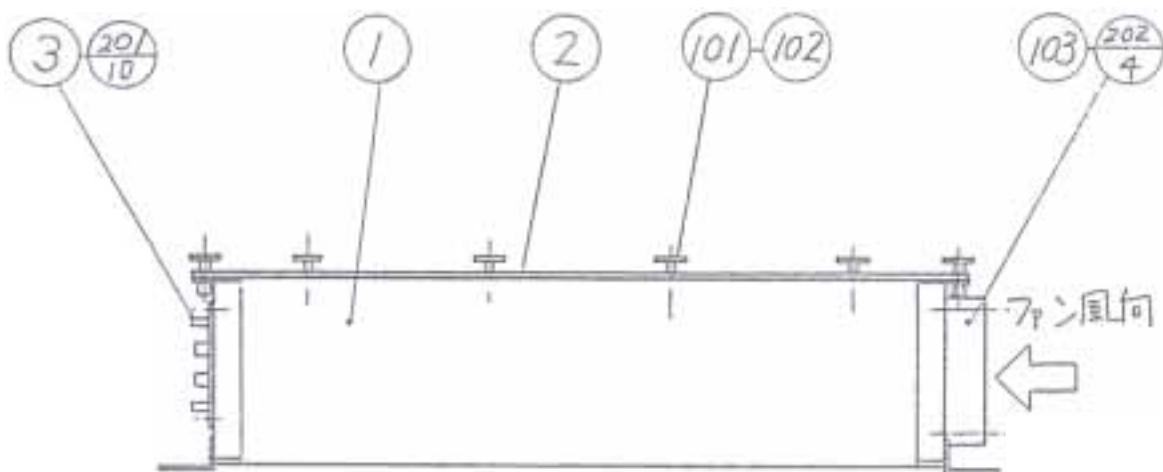

ITEM NO.	PART NO.	DESCRIPTION	NOTE
1	BVG-0002	SHIELD CASE MAIN	
2	BVG-0003	SHIELD CASE LID MAIN	
3	839-0531	FILTER BD MAIN	
101	280-5079	NYLATCH GROMMET	
102	280-5080	NYLATCH PLUNGER	
103	260-0046	FAN MOTOR DC5V	
	260-0049	FAN MOTOR DC5V (IKURA SEIKI D92A2H)	
104	209-0023	CONN CLOSED END	
201	010-0308-F	S-TITE SCR PH W/F M3×8	
202	000-0335-F	M SCR PH W/F M3×35	
301	600-6178-71	WIRE HARN RGB	
302	600-6178-106	WIRE HARN SHIELD CASE FAN	

③ ASSY NUMBER BOX (BVG 0100)

1/2)

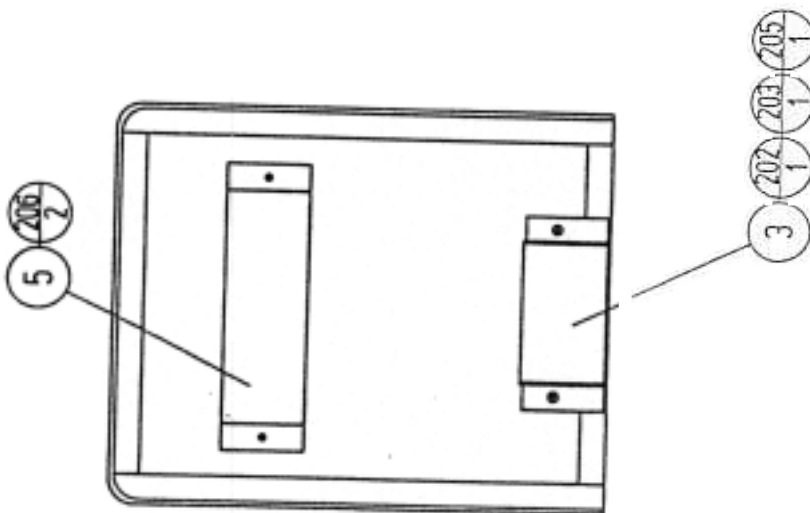
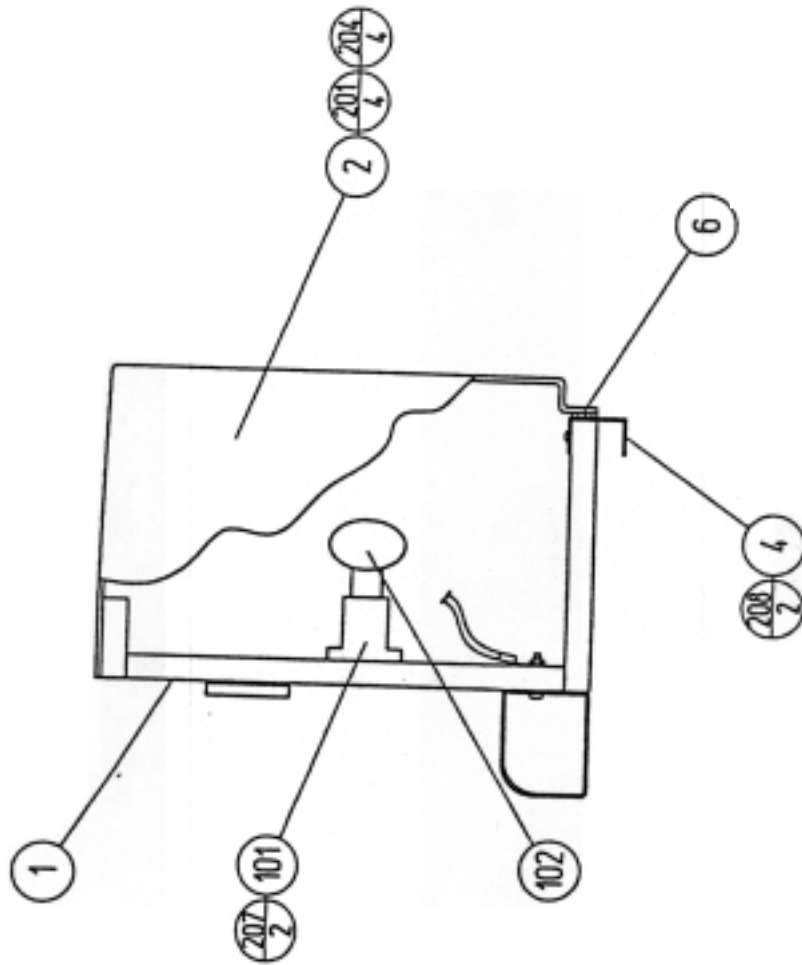

③ ASSY NUMBER BOX (BVG-0100)

(D-2/2)

ITEM NO.	PART NO.	DESCRIPTION	NOTE
1	BVG-0101	NUMBER BOX	
2	BVG-0102	NUMBER PLATE FRAME	
3	BVG-0103	WIRE COVER	
4	BVG-0104	HOOK PLATE	
5	BVG-0105	BLIND LID	
6	BVG-0106	SPACER	
101	214-0110	BULB SOCKET	
102	390-5412	LAMP 110V 25W (TOZAI S35 E17 C)	
103	280-0419	HARNESS LUG	
104	601-0460	PLASTIC TIE BELT 100mm	
201	029-0169	TMP PRF SCR TH CHROME M4×16	
202	008-0416	TMP PRF SCR TH M4×16	
203	008-0425	TMP PRF SCR TH M4×25	
204	069-0110	FLT WSHR CRM 4.4-16×1.6	
205	051-0004	FLG NUT M4	
206	029-0059	W SCR RH BLK W/F 3.5×16	
207	005-3120	W SCR RH 3.1×20	
208	000-0416-S	M SCR PH W/S M4×16	
301	600-6190-144	WIRE HARN LAMP	

④ ASSY BILLBOARD (BVG-0150)

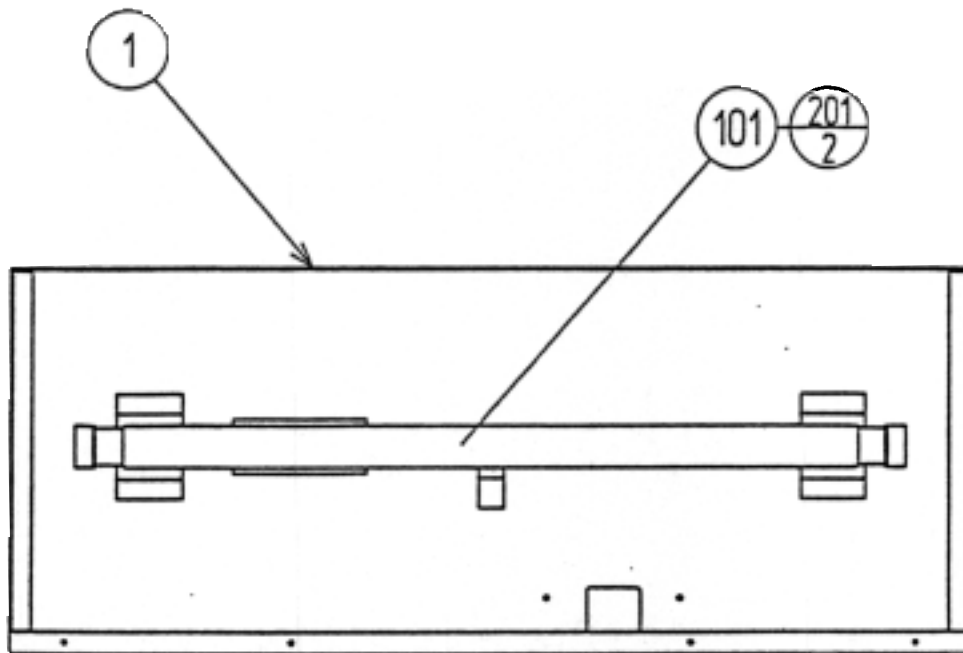

ITEM NO.	PART NO.	DESCRIPTION	NOTE
1	BVG-0151	BILLBOARD BOX	
101	390-5276-20-01	ASSY FL UNIT 20W EX	
102	209-0032	CONN CLOSED END	
103	601-0460	PLASTIC TIE BELT 100mm	
104	280-5225	CORD CLAMP 21	
201	000-0416-FS	M SCR PH W/FS M4×16	
301	600-6190-138	WIRE HARN FRONT BILL BD.	



THIS PAGE INTENTIONALLY OMITTED

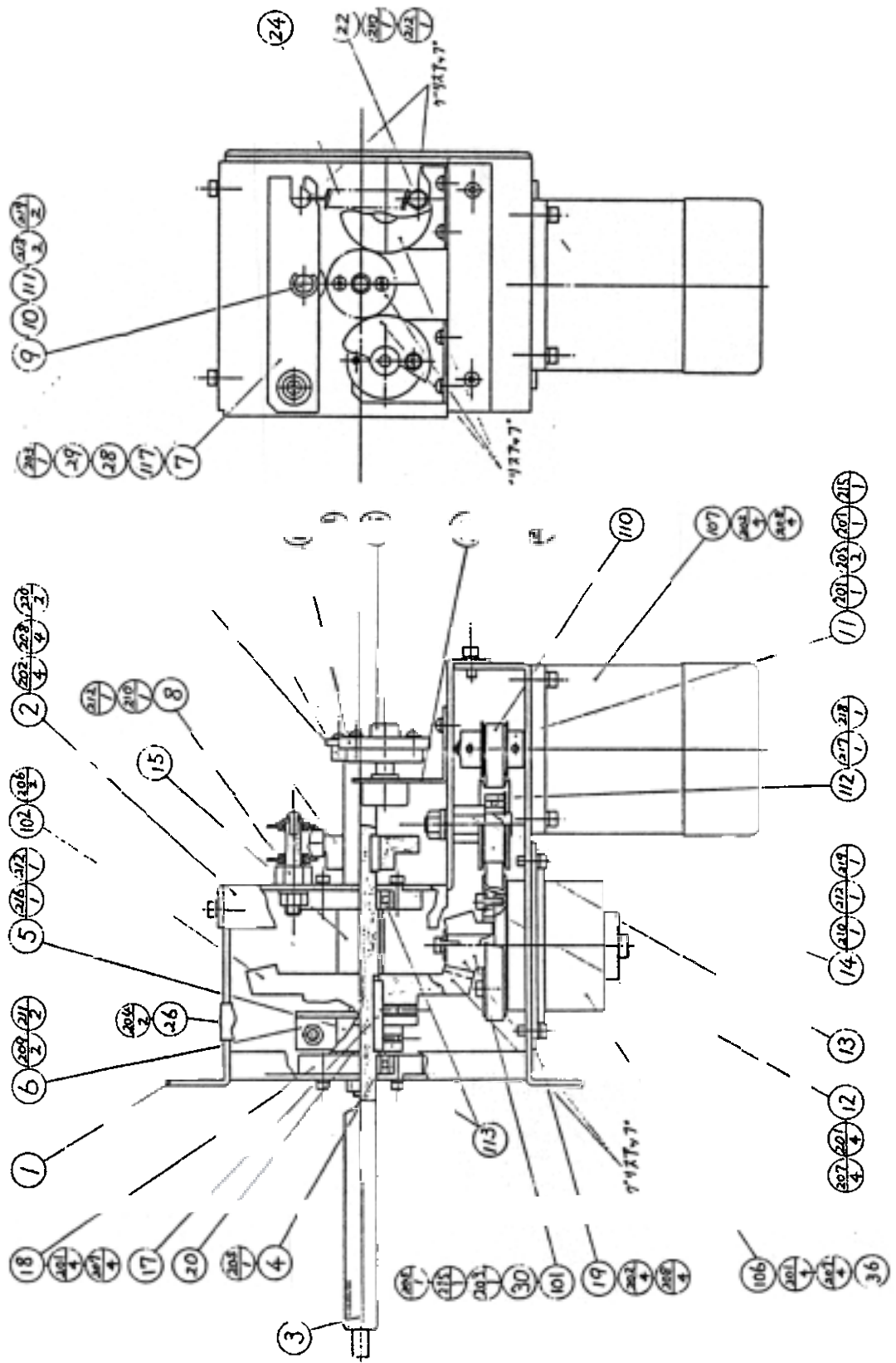

ASSY HANDLE MECHA (BVG-1350)

(D-2/5)

ITEM NO.	PART NO.	DESCRIPTION	NOTE
1	BVG-1311	HANDLE BASE	
2	BVG-1312	HANDLE LID	
3	BVG-1313	HANDLE SHAFT	
4	BVG-1314	STOPPER ARM	
5	BVG-1315	STOPPER RUBBER	
6	BVG-1316	STOPPER BRKT	
7	BVG-1317	SWING ARM	
8	BVG-1318	SWING ARM SHAFT	
9	SOR-2112	BEARING SHAFT	
10	SOR-2113	SPACER	
11	BVG-1319	DRIVE PULLY	
12	BVG-1320	DRIVEN PULLY	
13	BVG-1321	TENSIONER PULLY	
14	BVG-1322	TENSIONER SHAFT	
15	BVG-1323	CENTER COLLAR	
16	SLC-1141X	WHITE CAM	
17	BVG-1324	STOPPER KEY	
18	BVG-1325	BEARING HOUSING	
19	BVG-1326	CLUCH PLATE	
20	BVG-1327	SPACER 20-26×2	
21	POW-2008	KEY	
22	BVG-1329	SPRING HOOK	
23	BVG-1330	VR BRKT	
24	BVG-1331	EXT SPRING	
25	BVG-1221	GEAR HOLDER	
26	BVG-1339	WIRE LID	

⑧ ASSY HANDLE MECHA (BVG-1350)

(D-3/5)

ITEM NO.	PART NO.	DESCRIPTION	NOTE
27	SLC-1130	ADJUST RING	
28	BVG-1340	FLT WSHR 8.1-12×2	
29	BVG-1341	FLT WSHR 4.1-12×2	
30	BVG-1342	KEY 4×3.7×16	
31	BVG-1344	ADJUST PLATE 0.2	
32	BVG-1345	ADJUST PLATE 0.4	
33	BVG-1346	ADJUST PLATE 0.6	
34	BVG-1347	ADJUST PLATE 0.8	
35	BVG-1348	ADJUST PLATE 1.0	
36	BVG-1349	SPACER PLATE	
101	601-6957-92	BEVEL GEAR 15	
102	601-6958	BEVEL GEAR 60	
103	601-6172	GEAR 48	
104	601-6959	GEAR 64	
105	220-5373	VOL CONT B-5K OHM	
106	601-6946	PARTICLE CLUTCH BRAKE (OGURA OPC-20)	
107	350-5235	MOTOR AC100V 1250/1550rpm W/H	
108	280-5008	CORD CLAMP φ15	
109	601-0460	PLASTIC TIE BELT 100mm	
110	350-5240	TIMING VELT 5M TYPE (ニッタ(株) 375-5M-9)	
111	100-5018	BALL BEARING φ8	
112	100-5133	BEARING φ32 (NSK 6201 ZZ)	
113	100-5112	BEARING φ17 (NSK 6003 ZZ)	
114	209-0023	CONN CLOSED END	
115	310-5029-F10	SUMITUBE F F10MM	

ASSY HANDLE MECHA (BVG-1350)

(D-4/5)

ITEM NO.	PART NO.	DESCRIPTION	NOTE
116	310-5029-G20	SUMITUBE F G20MM	
117	100-5041	BEARING (NSK F688ZZ)	
201	029-0427	HEX SKT H CAP SCR M4×10	
202	029-0428	HEX SKT H CAP SCR M5×12	
203	000-0412-FS	M SCR PH W/FS M4×12	
204	000-0310-FS	M SCR PH W/FS M3×10	
205	028-0019	SET SCR HEX SKT CP UNBR M4×8	
206	028-0053	SET SCR HEX SKT CP M6×8	
207	061-0004	SPR WSHR M4	
208	061-0005	SPR WSHR M5	
209	061-0006	SPR WSHR M6	
210	061-0008	SPR WSHR M8	
211	050-0006	HEX NUT M6	
212	050-0008	HEX NUT M8	
213	065-0007	E RING 7mm	
214	028-0034	SET SCR HEX SKT CUP M3×8	
215	069-0007	FLT WSHR 4.4-16×1.6	
216	030-0845	HEX BLT M8×45	
217	069-0144	STP RING S12	
218	069-0145	STP RING H32	
219	060-0008	FLT WSHR M8	
220	060-0005	FLT WSHR M5	
221	069-0148	FLT WSHR 20-26×0.2	
301	600-6190-37	WIRE HARN HANDLE VR	



f) ASSY BUTTERFLY SH I T (BVG 1353X)

(D- '2)

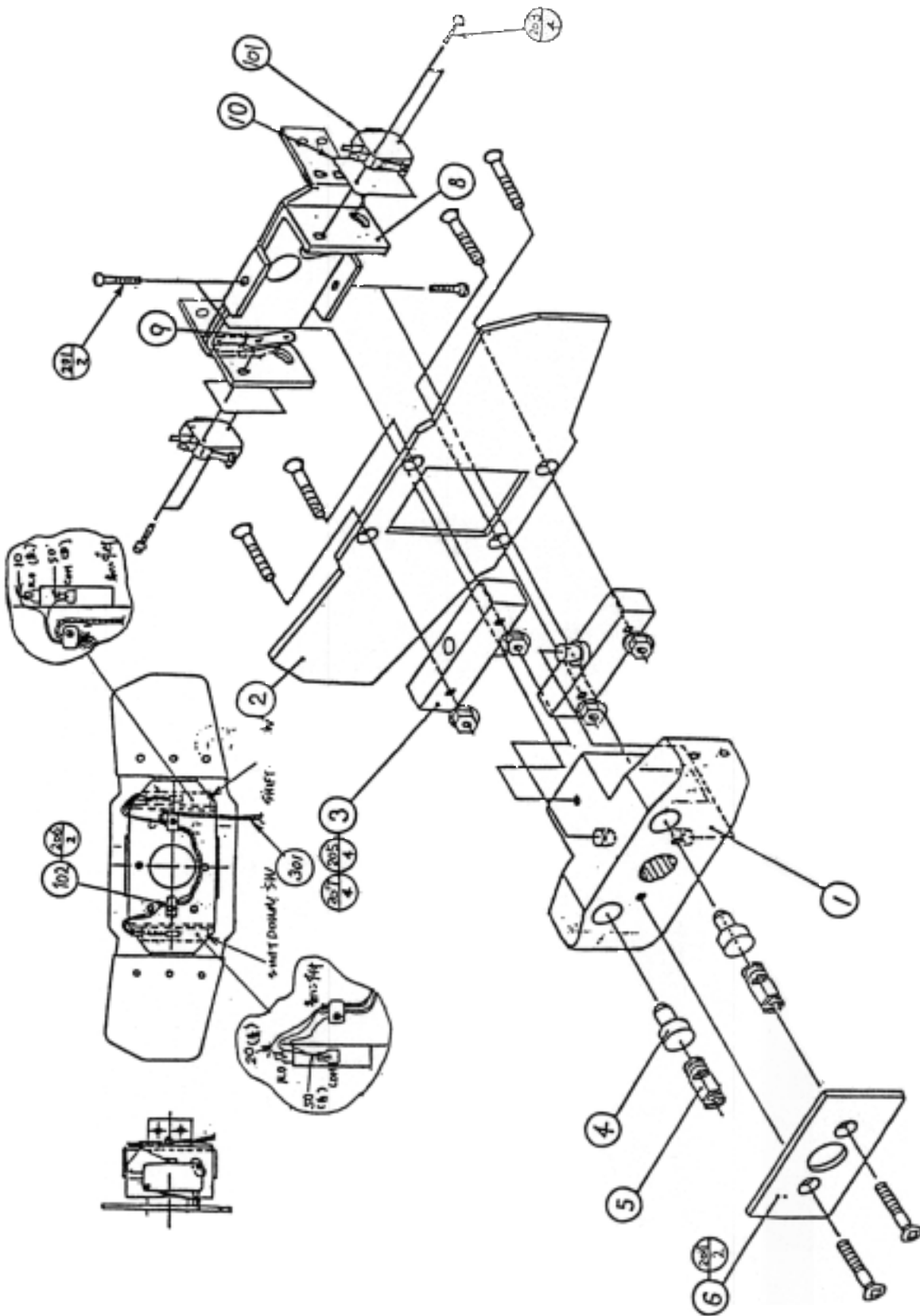

⑨ ASSY BUTTERFLY SHIFT (BVG-1353X)

(D-2/2)

ITEM NO.	PART NO.	DESCRIPTION	NOTE
1	BVG-1351	BOSS	
2	SLC-1313	SHIFT PLATE	
3	SLC-1314	PIVOT	
4	SLC-1315X	PLUNGER	
5	SLC-1316	COMP SPRING	
6	SLC-1317	SPRING LID	
8	BVG-1354	SW BRKT	
9	117-0141	PLATE LOCK	
10	310-0012	PAPER INSULATOR	
101	509-5387	SW MICRO TYPE (AH71557K)	
102	280-5124-03	NYLON CLAMP NK03	
201	000-0408-S	M SCR PH W/S M4×8	
203	000-0316-FS	M SCR PH W/FS M3×16	
204	001-0512	M SCR FH M5×12	
205	001-0525	M SCR FH M5×25	
206	010-0312-F	S-TITE. SCR PH W/F M3×12	
207	051-0005	FLG NUT M5	
301	600-6190-40	WIRE HARN SHIFT SW	



⑩ ASSY FRONT SUB CABINET (BVG-1500)

(D-1/4)

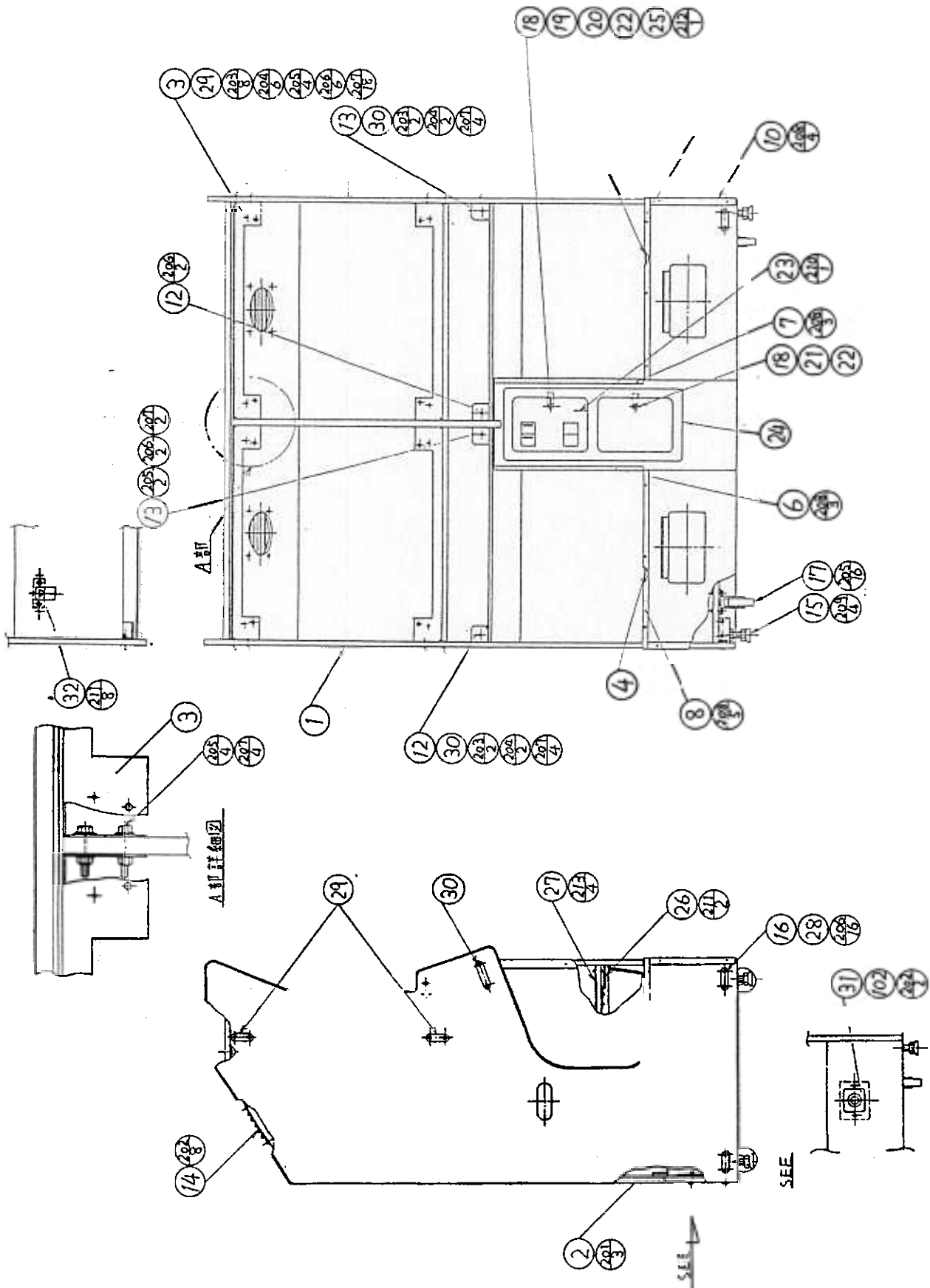

⑩ ASSY FRONT SUB CABINET (BVG-1500)

(D-2/4)

ITEM NO.	PART NO.	DESCRIPTION	NOTE
1	BVG-1501	WOODEN FRONT CABINET	
2	BVG-1502	BACK BOARD	
3	BVG-1503	MONITOR BRKT	
4	BVG-1504	FLOOR MAT LEFT	
5	BVG-1505	FLOOR MAT RIGHT	
6	BVG-1506	PROTECTOR CENTER-L	
7	BVG-1507	PROTECTOR CENTER-R	
8	BVG-1508	CORNER PROTECTOR-L	
9	BVG-1509	CORNER PROTECTOR-R	
10	BVG-1510	PROTECTOR UNDER	
12	BVG-1512	CONT HOLDER BRKT L	
13	BVG-1513	CONT HOLDER BRKT R	
14	UP-1018	AIR VENT	
15	601-5699	LEG ADJUSTER BOLT M16×75	
16	ARC-1006	LEG BRACKET	
17	601-5471	CASTER	
18	DP-1167	TNG LKG	
19	220-5380	MAG LOCK MASTER W/O KEY	
20	220-5381	KEY MASTER FOR 220-5380	
21	220-5046-91	MAGNETIC LOCK W/KEYS	
22	HN-1050	SPACER RING	
23	109-0045	KEY HOLDER	
24	220-5128~	ASSY COIN CHUTE 2DOOR ~	OTHER
	220-5374	DOUBLE DOOR FRAME W/CASH DOOR	FOR MARS DOOR
25	105-5068	PLATE TONGUE STOPPER	
26	105-5169	LOCK BRACKET W	

⑩ ASSY FRONT SUB CABINET (BVG-1500)

(D-3/4)

ITEM NO.	PART NO.	DESCRIPTION	NOTE
27	105-5172	CHUTE PLATE DOUBLE	OTHER
	105-5374	CHUTE PLATE MARS	FOR MARS DOOR
28	117-5233	PLATE LEG BRACKET BLACK	
29	117-5234	PLATE 6-40	
30	117-5236	PLATE 6-60	
31	BVG-1025	COMMUNICATION PLATE	
32	BVG-0014	CONNECTOR PLATE	
101	601-0460	PLASTIC TIE BELT 100mm	
102	280-5234	RUBBER GROMMET $\phi$ 26 W/COVER	
201	008-0430	TMP PRF SCR TH M4 $\times$ 30	
202	008-0420	TMP PRF SCR TH M4 $\times$ 20	
203	039-0127	CRG BLT CRM M6 $\times$ 40	
204	031-0630-B	CRG BLT BLK M6 $\times$ 30	
205	039-0126	HEX BLT W/FS M6 $\times$ 35	
206	039-0112	HEX BLT BLK W/FS M6 $\times$ 25	
207	051-0006	FLG NUT M6	
208	046-0001	SCR NAIL THH STNLS 1.5 $\times$ 16	
209	059-0022	HEX NUT M16	
210	000-0308-FS	M SCR PH W/FS M3 $\times$ 8	
211	000-0416-FS	M SCR PH W/FS M4 $\times$ 16	
212	000-0435	M SCR PH M4 $\times$ 35	
213	005-3513-F	W SCR RH W/F 3.5 $\times$ 13	
301	600-6190-46	WIRE HARN COIN LP	



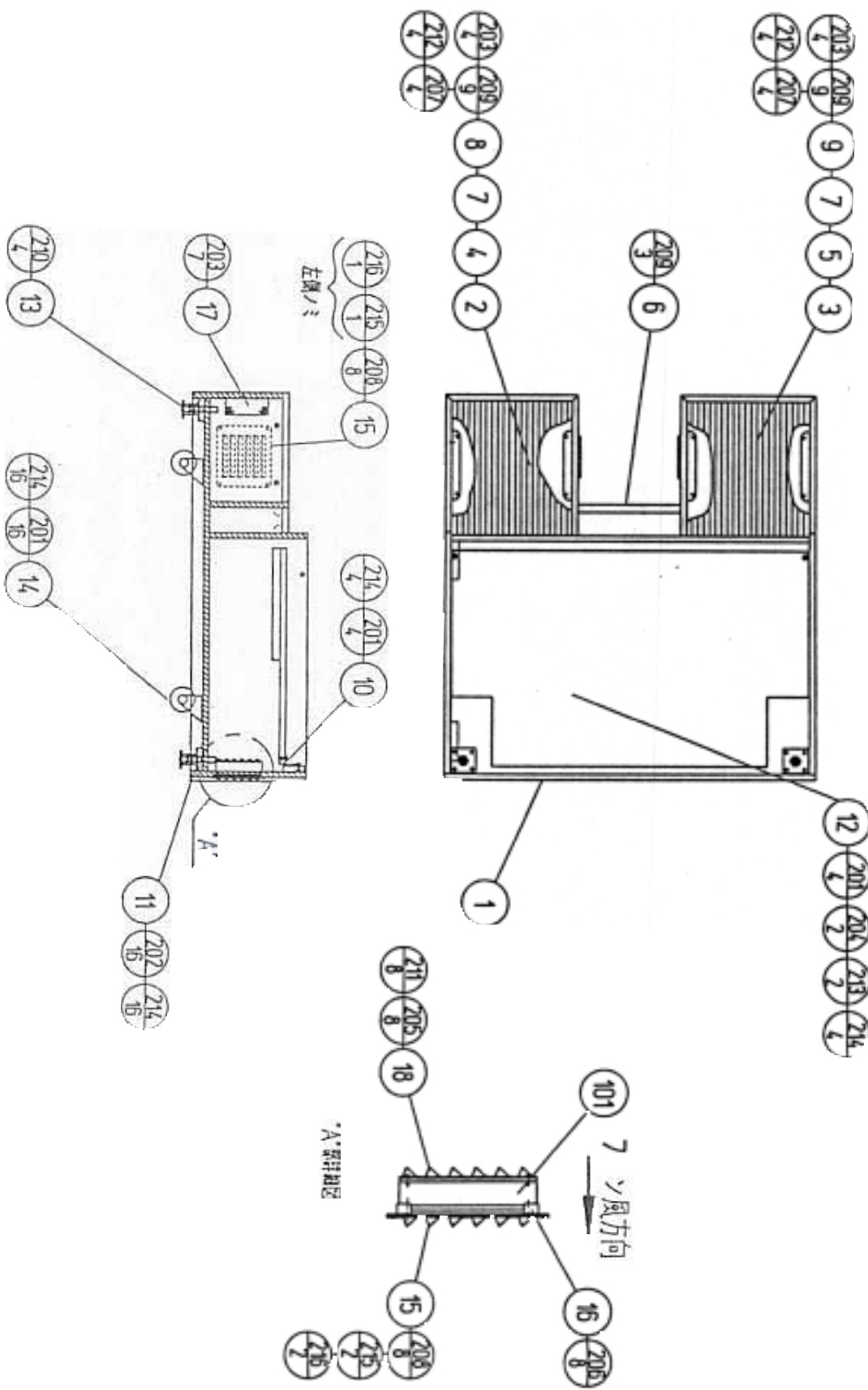

⑪ ASSY REAR SUB CABINET (BVG-2050)

(D-2/2)

ITEM NO.	PART NO.	DESCRIPTION	NOTE
1	BVG-2051	REAR CABINET	
2	BVG-2052	EDGE GUARD L	
3	BVG-2053	EDGE GUARD R	
4	BVG-2054	FLOOR MAT L	
5	BVG-2055	FLOOR MAT R	
6	BVG-2056	PROTECTOR FRONT	
7	BVG-2057	LID BRKT	
8	BVG-2058	MAINTENANCE LID L	
9	BVG-2059	MAINTENANCE LID R	
10	BVG-2060	HINGE 700	
11	BVG-2061	LEG ADJUSTER PLATE	
12	BVG-2062	BOARD BASE	
13	601-5699	LEG ADJUSTER BOLT M16×75	
14	601-5471	CASTER	
15	BVG-2064	AIR VENT WHITE	
16	HN-1042X	FAN BRKT	
17	BVG-2075	CORNER BRKT	
18	BVG-2076	AIR VENT INNER	
101	260-0044	FAN MOTOR DC24V (TOYO TD12A7H)	
	260-0048	FAN MOTOR DC24V	
102	209-0023	CONN CLOSED END	

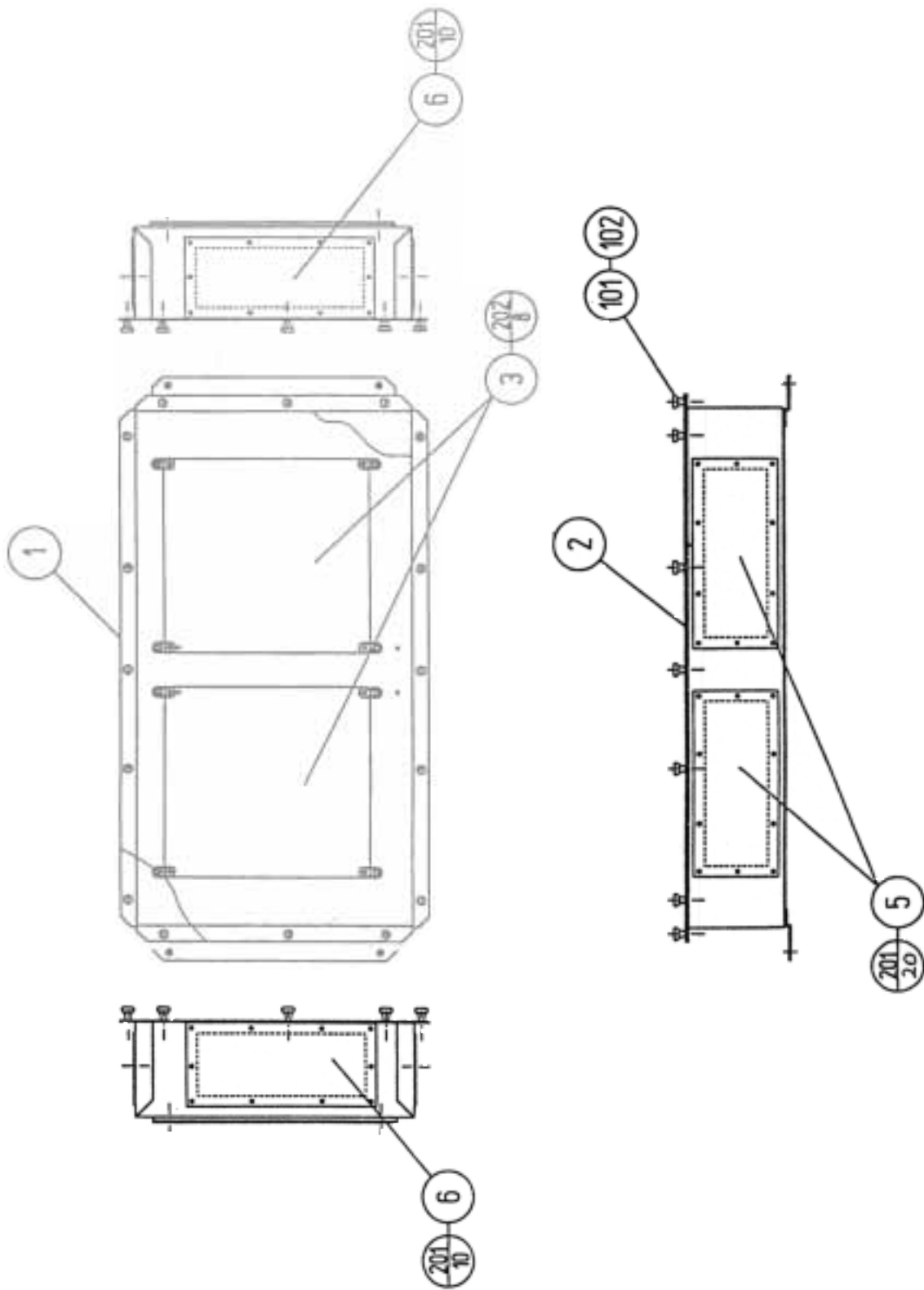



⑫ ASSY SHIELD CASE /O TWIN (BVG-2063)

(D-2/2)

ITEM NO.	PART NO.	DESCRIPTION	NOTE
1	BVG-2068	SHIELD CASE TWIN	
2	BVG-2069	SHIELD CASE LID TWIN	
3	837-8936	I/O BD VIRTUA RACING	
5	839-0532	FILTER BD I/O A	
6	839-0533	FILTER BD I/O B	
101	280-5079	NYLATCH GROMMET	
102	280-5080	NYLATCH PLUNGER	
103	601-0460	PLASTIC TIE BELT 100mm	
201	010-0310-F	S-TITE SCR PH W/F M3×10	
202	029-0024	S-TITE SCR FH M3×8	
301	600-6190-120	WIRE HARN I/O SHIELD CASE LP 1	
302	600-6190-121	WIRE HARN I/O SHIELD CASE LP 2	
303	600-6190-122	WIRE HARN I/O SHIELD CASE LP 3	
304	600-6190-123	WIRE HARN I/O SHIELD CASE LP 4	
305	600-6190-124	WIRE HARN I/O SHIELD CASE LP 5	
306	600-6190-125	WIRE HARN I/O SHIELD CASE LP 6	
307	600-6190-126	WIRE HARN I/O SHIELD CASE RP 1	
308	600-6190-127	WIRE HARN I/O SHIELD CASE RP 2	
309	600-6190-128	WIRE HARN I/O SHIELD CASE RP 3	
310	600-6190-129	WIRE HARN I/O SHIELD CASE RP 4	
311	600-6190-130	WIRE HARN I/O SHIELD CASE RP 5	
312	600-6190-131	WIRE HARN I/O SHIELD CASE RP 6	



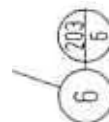
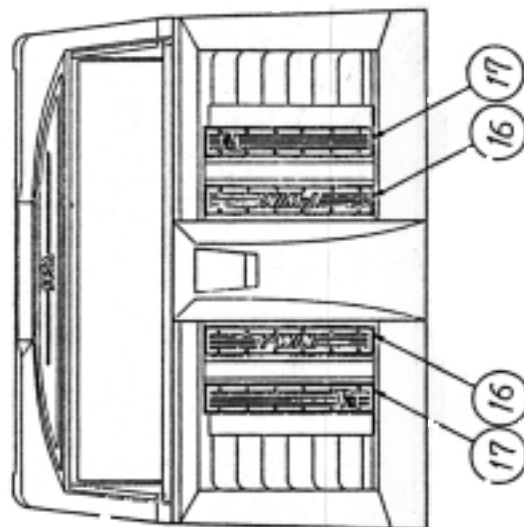

⑬ ASSY SEAT (BVG-2065)

(D-2/3)

ITEM NO.	PART NO.	DESCRIPTION	NOTE
1	BVG-2070	FRONT PIECE	
2	BVG-2071	BACK PIECE	
3	BVG-2072	TOP PIECE	
4	BVG-2073	SPEAKER NET	
6	BVG-2078	TNG RETAINER	
7	BVG-2080	SP. BASE	
8	BVG-2081	SP. BRKT	
9	BVG-2082	JOINT BRKT	
10	BVG-2083	UPPER HOLDER	
11	BVG-2084	LOWER HOLDER	
12	BVG-2085	BILLBOARD BVG TWIN	
13	BVG-2086	ASSY HINGE R	
14	BVG-2087	ASSY HINGE L	
16	BVG-2091	STICKER T-WIN	
17	BVG-2092	STICKER V12	
101	130-5078	ASSY SPEAKER BOX YST	
102	390-5276-30-01	ASSY FL UNIT 30W EX	
103	209-0032	CONN CLOSED END	
104	601-0460	PLASTIC TIE BELT 100mm	
105	280-5225	CORD CLAMP 21	
201	000-0425-FS	M SCR PH W/FS M4×25	
202	000-0512	M SCR PH M5×12	
203	001-0512	M SCR FH M5×12	
204	001-0516	M SCR FH M5×16	



①④ ASSY FRONT CAB NET (BVG 0001

(D-1/6

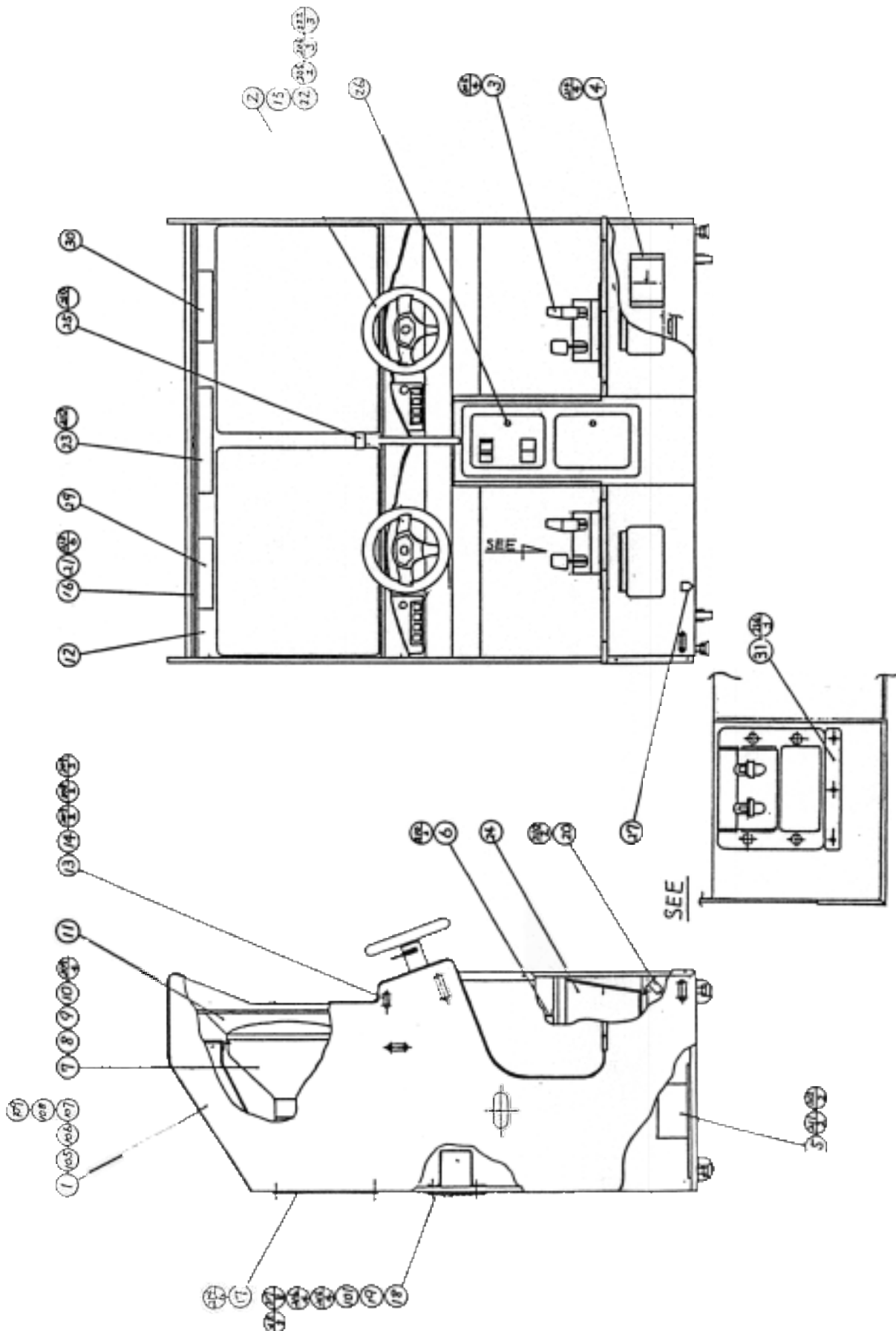

⑭ ASSY FRONT CABINET (BVG-10001)

(D-2/6)

ITEM NO.	PART NO.	DESCRIPTION	NOTE
1	BVG-1500	ASSY FRONT SUB CABINET	
2	BVG-13004	ASSY CONT PNL TWIN W/COVER MARS	FOR MARS DOOR
	BVG-13005	ASSY CONT PNL TWIN W/COVER EXP	OTHER
3	BVG-14001	ASSY ACCEL & BRAKE	
4	BVG-1015	AC UNIT	
5	BVG-40003	ASSY TRANSFORMER	
6	BVG-1016	SW UNIT	
7	200-5187-24	ASSY CLR DSPL 26 TYPE 24K 100V (NANA0)	
	200-5195-24	ASSY CLR DSPL 26 TYPE 24K 100V (SANWA)	
8	280-5112	BUSH FOR TV	
9	280-5113	COLLAR FOR TV	
10	280-5114	SPACER 6.4-25×2	
11	RDY-1028	TV MASK 26TYPE	
12	BVG-1007	FRONT GLASS	
13	BVG-1008	PANEL MOUNT BRKT	
14	117-5235	PLATE 6-30	
15	BVG-1009	GLASS HOLDER	
16	BVG-1010	GLASS GUIDE UPPER	
17	BVG-1011	REAR LID	
18	BVG-2005	AIR VENT	
19	BVG-2006	CROSS FAN HOLDER	
20	BVG-1012	METER UNIT	
21	BVG-1013	CUSHION L	
22	BVG-1014	CUSHION S	
23	422-0426-01	PLY INSTR SH V. R. TWIN ENG	
24	253-5366	CASH BOX	

⑭ ASSY FRONT CABINET (BVG-10001)

(D-3/6)

ITEM NO.	PART NO.	DESCRIPTION	NOTE
25	421-7308~	DENOMINATION SHEET 1GAME~	
26	421-6682	STICKER SERVICE INSTR	
27	421-7020	STICKER CAUTION FORK	
28	421-7993	STICKER FOR INSTR	
29	BVG-1017	STICKER FRONT GLASS NO. 1	
30	BVG-1018	STICKER FRONT GLASS NO. 2	
31	BVG-1031	FLOOR PLATE	
101	260-0045	CROSS FLOW FAN DC50V	
102	280-5225	CORD CLAMP 21	
103	280-0419	HARNESS LUG	
104	601-0460	PLASTIC TIE BELT 100mm	
105	117-5166	TERMINAL 5P-5P SHORT	
106	400-5101	SW REGU AC90-240V +50V 1A	
108	838-9081	VARIABLE REG AND MOTOR CTRL BD	
109	839-0233-02	SSR AC 2A DC 5V BD	
110	270-5009	LINE FILTER	
201	005-3516	W SCR RH 3.5×16	
202	005-3125	W SCR RH 3.1×25	
203	005-3113-F	W SCR RH W/F 3.1×13	
204	006-3110	W SCR FH 3.1×10	
205	039-0154	HEX BLT BLK W/FS M8×30	
206	029-0433	TMP PRF SCR TH M6×30	
207	039-0126	HEX BLT W/FS M6×35	
208	039-0087	CRG BLT CRM M6×30	

⑭ ASSY FRONT CABINET (BVG-10001)

(D-4/6)

ITEM NO.	PART NO.	DESCRIPTION	NOTE
209	051-0006	FLG NUT M6	
210	000-0416-FS	M SCR PH W/FS M4×16	
211	000-0530-S	M SCR PH W/S M5×30	
212	069-0001	FLT WSHR 5.5-20×1.6	
213	008-0416	TMP PRF SCR TH M4×16	
214	008-0420	TMP PRF SCR TH M4×20	
216	031-0525-B	CRG BLT BLK M5×25	
217	051-0005	FLG NUT M5	
218	000-0408-FS	M SCR PH W/FS M4×8	
219	090-0009	DOUBLE FACE TAPE 10mm×50M/ROLL (NITTO N0501)	
220	090-0024	SCOCH ELEC. TAPE UL10 19mm×55M	
221	069-0017	FLT WSHR BLK M5	
222	069-0028	FLT WSHR BLK 6.2-15×1.2	
301	600-6190-03	WIRE HARN XFMR PWR	
302	600-6190-04	WIRE HARN XFMR UNIT PWR	
303	600-6190-05	WIRE HARN 50V REG PWR	
304	600-6190-06	WIRE HARN XFMR UNIT EARTH	
305	600-6190-07	WIRE HARN CROSS FAN 1	
306	600-6190-08	WIRE HARN CROSS FAN 2	
307	600-6190-09	WIRE HARN EARTH JP	
309	600-6190-11	WIRE HARN HANDLE MECHA EXT 1	
310	600-6190-12	WIRE HARN HANDLE MECHA EXT 2	
311	600-6190-13	WIRE HARN CTRL BD EXT 1	
312	600-6190-14	WIRE HARN CTRL BD EXT 2	
313	600-6190-15	WIRE HARN CTRL BD EXT 3	



⑭ ASSY FRONT CABINET (BVG-10001)

(D-5/6)

ITEM NO.	PART NO.	DESCRIPTION	NOTE
314	600-6190-16	WIRE HARN CTRL BD EXT 4	
315	600-6190-17	WIRE HARN CTRL BD EXT 5	
316	600-6190-18	WIRE HARN CTRL BD PWR 1	
317	600-6190-19	WIRE HARN CTRL BD PWR 2	
318	600-6190-20	WIRE HARN CTRL BD PWR 3	
319	600-6190-21	WIRE HARN ELEC PWR EXT 1	
320	600-6190-22	WIRE HARN ELEC PWR EXT 2	
321	600-6190-23	WIRE HARN ELEC PWR EXT 3	
322	600-6190-24	WIRE HARN ELEC PWR EXT 4	
323	600-6190-25	WIRE HARN MONITOR PWR EXT 1	
324	600-6190-26	WIRE HARN MONITOR PWR EXT 2	
325	600-6190-27	WIRE HARN MONITOR RGB EXT 1	
326	600-6190-28	WIRE HARN MONITOR RGB EXT 2	
327	600-6190-29	WIRE HARN MONITOR DEMAG EXT1	
328	600-6190-30	WIRE HARN MONITOR DEMAG EXT2	
329	600-6190-31	WIRE HARN I/O LP EXT 1	
330	600-6190-32	WIRE HARN I/O LP EXT 2	
334	600-6190-36	WIRE HARN I/O LP EXT 6	
335	600-6190-48	WIRE HARN EXTEND LP EXT 1	
337	600-6190-80	WIRE HARN I/O RP EXT 1	
338	600-6190-81	WIRE HARN I/O RP EXT 2	
342	600-6190-85	WIRE HARN I/O RP EXT 6	





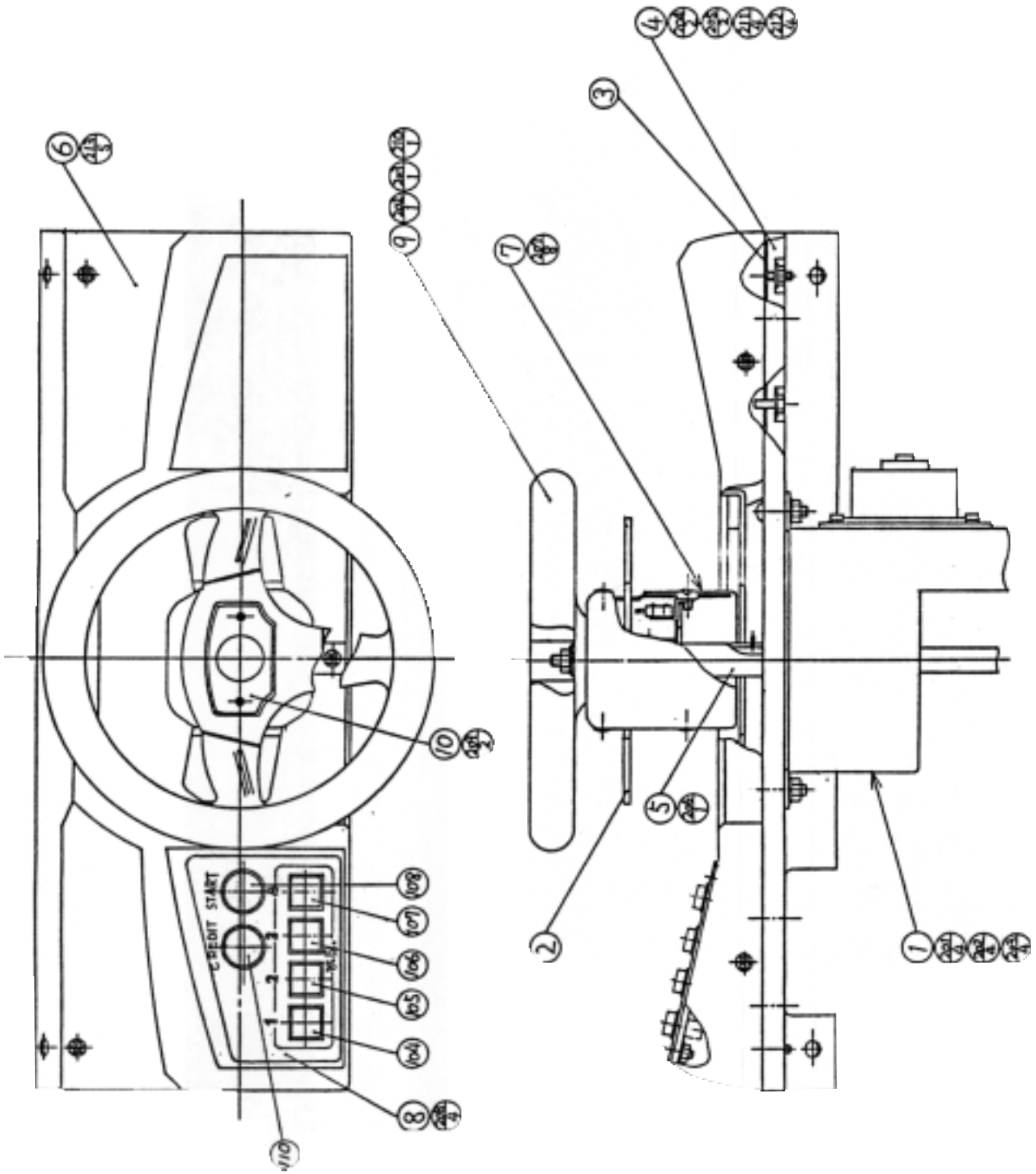

## 5) ASSY CONT PNL TWIN W/COVER MARS (BVG-13004

(D-2/3)

ITEM NO.	PART NO.	DESCRIPTION	NOTE
1	BVG-1350	ASSY HANDLE MECHA	
2	BVG-1353X	ASSY BUTTERFLY SHIFT	
3	BVG-1370	CONTROL PANEL N BLANK	
4	BVG-1371	CONTROL WOOD PANEL N	
5	BVG-1334X	HANDLE COLLAR	
6	BVG-1356	CONTROL PANEL OUTER	
7	BVG-1352	SHIFT COVER	
8	BVG-1359	SW PLATE MARS	
9	RDM-2001	STEERING WHEEL $\phi$ 270	
10	BVG-1212	STEERING EMBLEM BVG	
101	601-0460	PLASTIC TIE BELT 100mm	
102	280-5225	CORD CLAMP 21	
103	280-0419	HARNESS LUG	
104	509-5445-RE	SW PB RED 26 $\times$ 32 W/LAMP	
105	509-5445-BL	SW PB BLUE 26 $\times$ 32 W/LAMP	
106	509-5445-YE	SW PB YELLOW 26 $\times$ 32 W/LAMP	
107	509-5445-GR	SW PB GREEN 26 $\times$ 32 W/LAMP	
108	509-5218	PUSH BUTTON SW 1T YELLOW W/LAMP	
109	310-5033 -15-040	SPILAL TUBE $\phi$ 15 040CM	
110	509-5372	PUSH BUTTON SW 1T GREEN W/LAMP	
201	031-0830	CRG BLT M8 $\times$ 30	
202	050-0008	HEX NUT M8	
203	061-0008	SPR WSHR M8	
204	050-0006	HEX NUT M6	



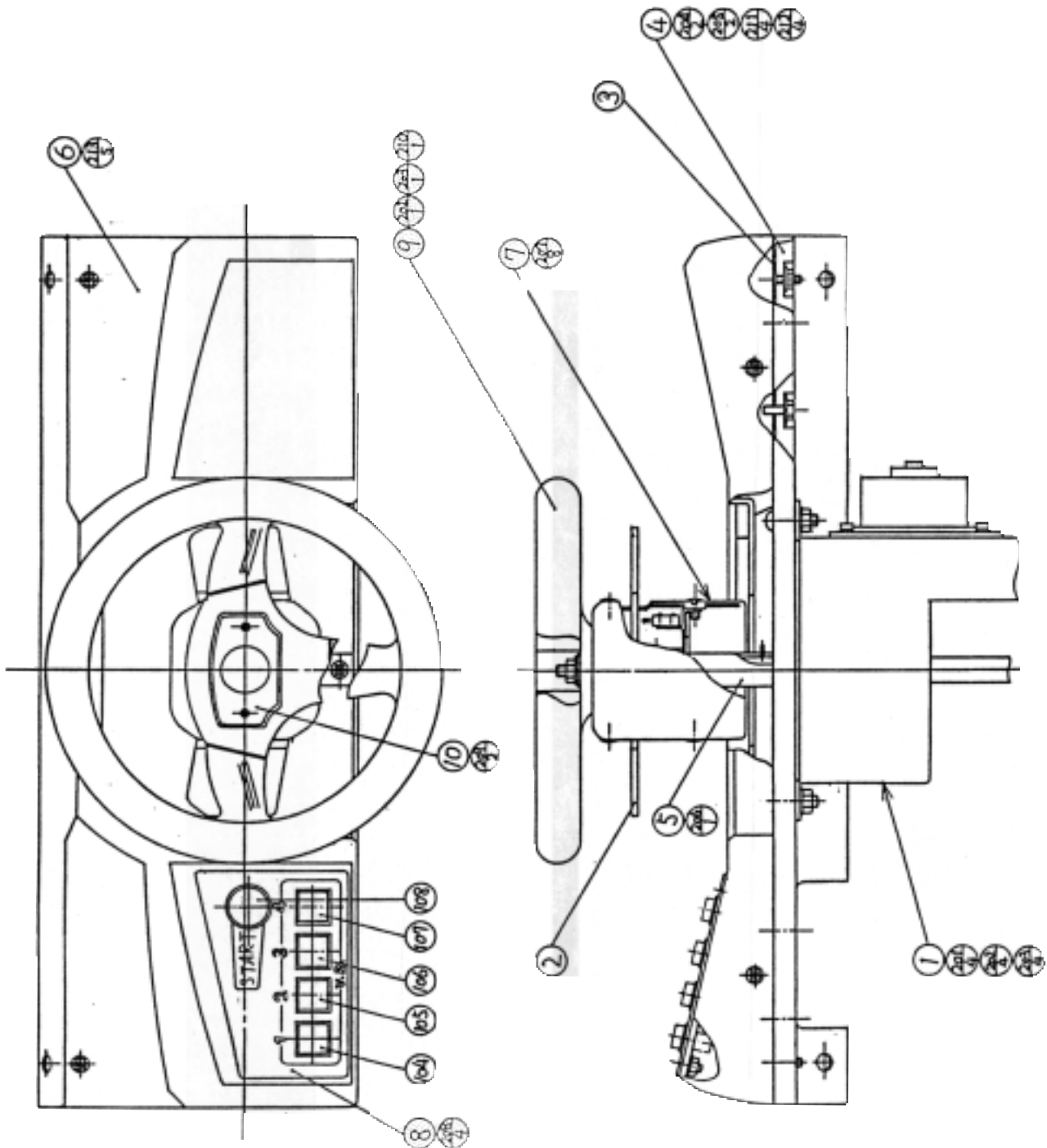



THIS PAGE INTENTIONALLY OMITTED

18 ASSY REAR CAB NET (BVG 20001

(D- /4

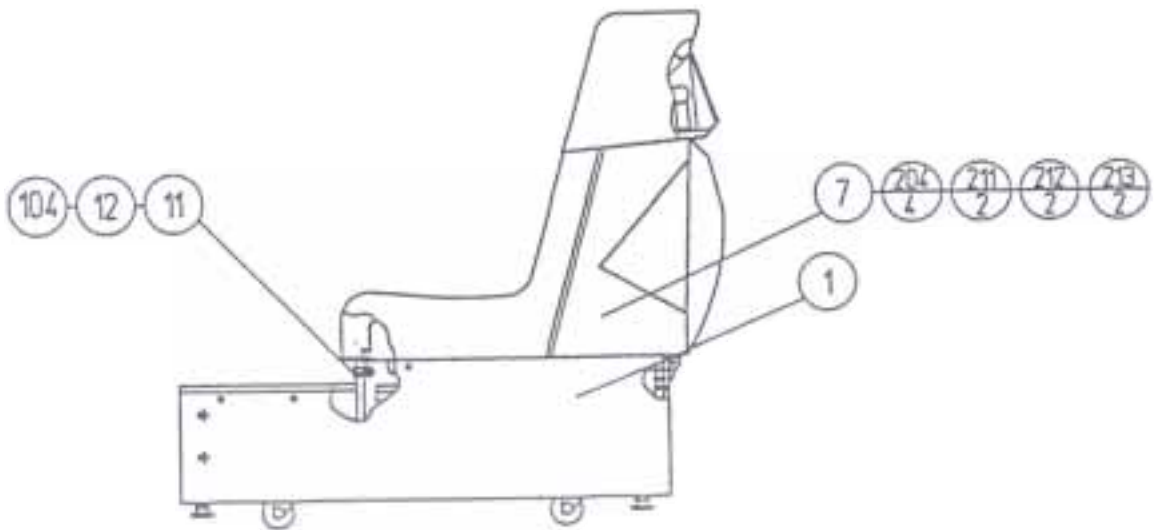
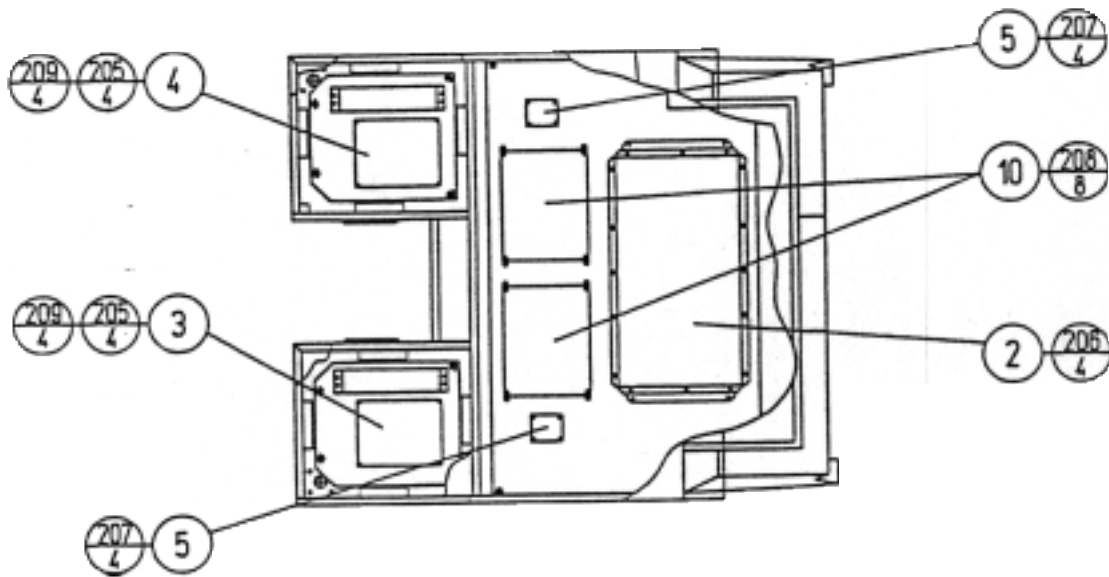



⑱ ASSY REAR CABINET (BVG-20001)

(D-2/4)

ITEM NO.	PART NO.	DESCRIPTION	NOTE
1	BVG-2050	ASSY REAR SUB CABINET	
2	BVG-2063	ASSY SHIELD CASE I/O TWIN	
3	BVG-40001	ASSY PWR SUPPLY LEFT	
4	BVG-40002	ASSY PWR SUPPLY RIGHT	
5	839-0542	AUDIO MIX BD	
7	BVG-2065	ASSY SEAT	
10	837-8939	SOUND BD VIRTUA RACING	
11	TH-1015	LOCKING TONGUE	
12	117-0062	PLATE LOCK RETAINER	
101	280-5225	CORD CLAMP 21	
102	280-0419	HARNESS LUG	
103	601-0460	PLASTIC TIE BELT 100mm	
104	220-5380	MAG LOCK MASTER W/O KEY	
201	005-3113-F	W SCR RH W/F 3.1×13	
202	006-3110	W SCR FH 3.1×10	
203	029-0024	S-TITE SCR FH M3×8	
204	039-0112	HEX BOLT BLK W/FS M6×25	
205	000-0430-S	M SCR PH W/S M4×30	
206	000-0416-FS	M SCR PH W/FS M4×16	
207	005-3125	W SCR RH 3.1×25	
208	006-3113	W SCR FH 3.1×13	
209	069-0007	FLT WSHR 4.4-16×1.6	
210	061-0004	SPR WSHR M4	
211	069-0111	FLT WSHR BLK 6.5-19×1.2	

18 ASSY REAR CABINET (BVG-20001)

(D-3/4)

ITEM NO.	PART NO.	DESCRIPTION	NOTE
212	039-0067	HEX BLT BLK M6×30	
213	069-0023	SPR WSHR BLK M6	
301	600-6190-60	WIRE HARN AMP J LP	
302	600-6190-61	WIRE HARN I/O BD PER LP	
303	600-6190-62	WIRE HARN JST TX LP	
304	600-6190-63	WIRE HARN JST RX LP	
305	600-6190-64	WIRE HARN SOUND BD PWR LP	
306	600-6190-65	WIRE HARN LINE MIX LP	
307	600-6190-66	WIRE HARN LINE OUT LP	
308	600-6190-67	WIRE HARN MAIN BD LP	
309	600-6190-68	WIRE HARN DC5V FAN LP EXT	
310	600-6190-69	WIRE HARN SP LP EXT	
311	600-6190-71	WIRE HARN REAR FL EXT	
312	600-6190-73	WIRE HARN DC24V FAN LP EXT	
313	600-6190-75	WIRE HARN RGB LP EXT	
314	600-6190-102	WIRE HARN AMP J RP	
315	600-6190-103	WIRE HARN I/O BD PWR RP	
316	600-6190-104	WIRE HARN JST TX RP	
317	600-6190-105	WIRE HARN JST RX RP	
318	600-6190-106	WIRE HARN SOUND BD PWR RP	
319	600-6190-108	WIRE HARN LINE MIX RP	
320	600-6190-109	WIRE HARN LINE OUT RP	
321	600-6190-110	WIRE HARN MAIN BD RP	
322	600-6190-111	WIRE HARN DC5V FAN RP EXT	
323	600-6190-112	WIRE HARN SP RP EXT	



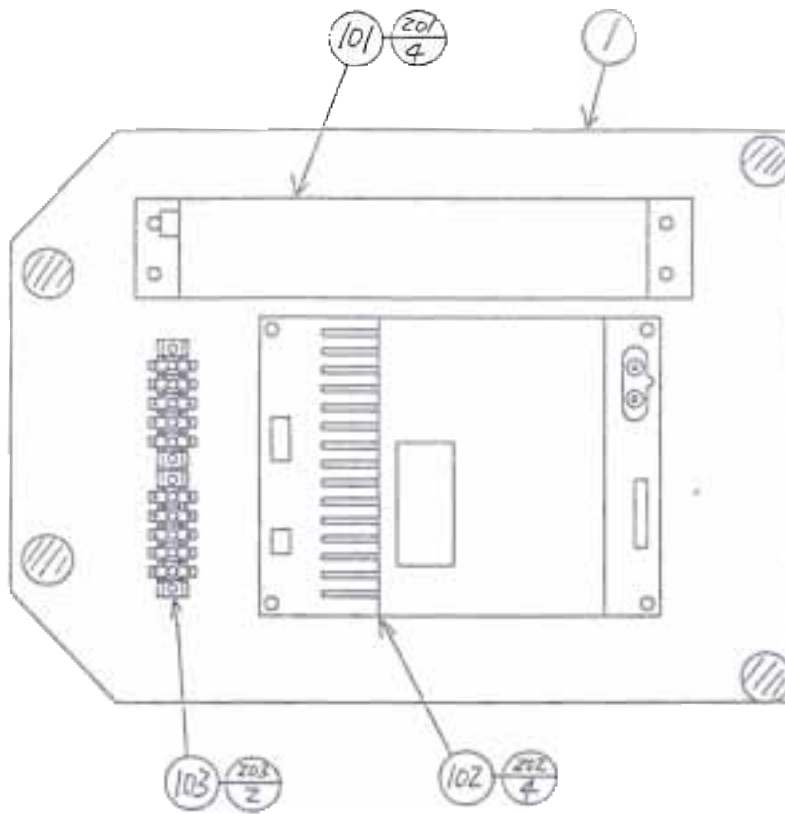

19 ASSY PWR SUPPLY LEFT (BVG-40001)

(D-2/2)

ITEM NO.	PART NO.	DESCRIPTION	NOTE
1	BVG-4003	WOODEN BASE TWIN	
101	400-5196	SW REGU +5V10A, +5V4A, +12V1A	
102	838-8689	AMP BD YST W/LOUDNESS	
103	117-5167	TERMINAL 5P-2P×2 SHORT	
104	280-5225	CORD CLAMP 21	
105	280-0425	CORD CLAMP $\phi$ 10	
106	601-0460	PLASTIC TIE BELT 100mm	
107	280-0419	HARNESS LUG	
201	005-3113-F	W SCR RH W/F 3.1×13	
202	005-3120	W SCR RH 3.1×20	
203	005-3516	W SCR RH 3.5×16	
204	006-3110	W SCR FH 3.1×10	
301	600-6190-50	WIRE HARN PWR SPLY LP 1	
302	600-6190-51	WIRE HARN PWR SPLY LP 2	
303	600-6190-52	WIRE HARN PWR SPLY LP 3	
304	600-6190-53	WIRE HARN PWR SPLY LP 4	
305	600-6190-54	WIRE HARN PWR SPLY LP 5	
306	600-6190-55	WIRE HARN PWR SPLY LP 6	
307	600-6190-56	WIRE HARN PWR SPLY LP 7	
308	600-6190-57	WIRE HARN PWR SPLY LP 8	

20 ASSY PWR SUPPLY R GHT (BVG 40002)

(D- /2)

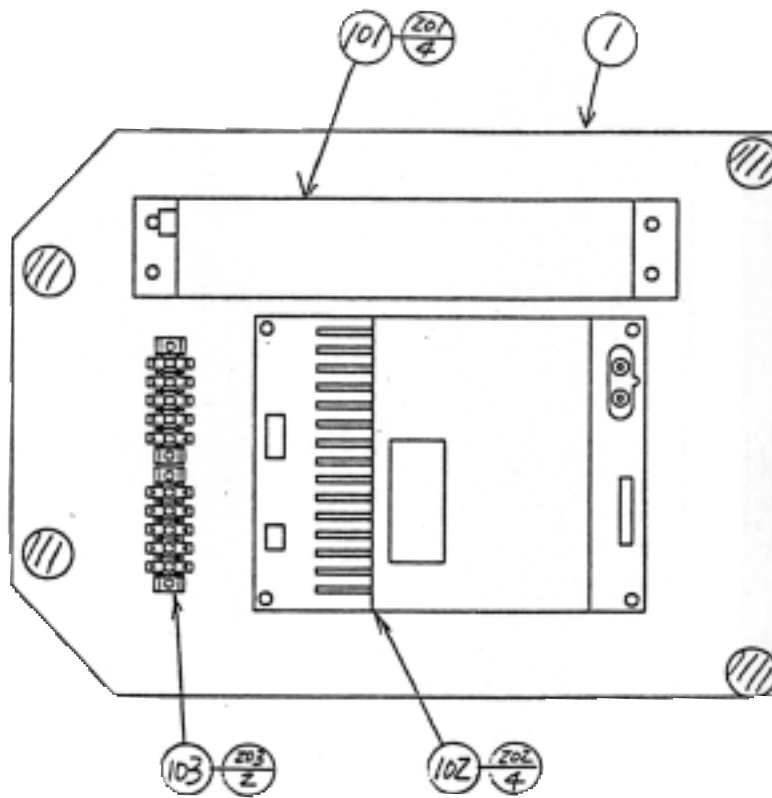

② ASSY PWR SUPPLY RIGHT (BVG-40002)

(D-2/2)

ITEM NO.	PART NO.	DESCRIPTION	NOTE
1	BVG-4003	WOODEN BASE TWIN	
101	400-5196	SW REGU +5V10A, +5V4A, +12V1A	
102	838-8689	AMP BD YST W/LOUDNESS	
103	117-5167	TERMINAL 5P-2P×2 SHORT	
104	280-5225	CORD CLAMP 21	
105	280-0425	CORD CLAMP $\phi$ 10	
106	601-0460	PLASTIC TIE BELT 100mm	
107	280-0419	HARNESS LUG	
201	005-3113-F	W SCR RH W/F 3.1×13	
202	005-3120	W SCR RH 3.1×20	
203	005-3516	W SCR RH 3.5×16	
204	006-3110	W SCR FH 3.1×10	
301	600-6190-92	WIRE HARN PWR SPLY RP 1	
302	600-6190-93	WIRE HARN PWR SPLY RP 2	
303	600-6190-94	WIRE HARN PWR SPLY RP 3	
304	600-6190-95	WIRE HARN PWR SPLY RP 4	
305	600-6190-96	WIRE HARN PWR SPLY RP 5	
306	600-6190-97	WIRE HARN PWR SPLY RP 6	
307	600-6190-98	WIRE HARN PWR SPLY RP 7	
308	600-6190-99	WIRE HARN PWR SPLY RP 8	

THIS PAGE INTENTIONALLY OMITTED



## 19. WIRE COLOR CODE TABLE

THE WIRE COLOR CODE is as follow

A	PINK
B	SKY BLUE
C	BROWN
D	PURPLE
E	LIGHT GREEN

Wires other than those of any of the above 5 single colors will be displayed by 2 alphanumeric characters.

1	RED
2	BLUE
3	YELLOW
4	GREEN
5	WHITE
7	ORANGE
8	BLACK
9	GRAY

If the right-hand side numeral of the code is 0, then the wire will be of a single color shown by the left-hand side numeral (see the above).

Note 1 : If the right-hand side alphanumeric is not 0, that particular wire has a spiral color code. The left-hand side character shows the base color and the right-hand side one, the spiral color.

< Example > 51                  WHITE / RED

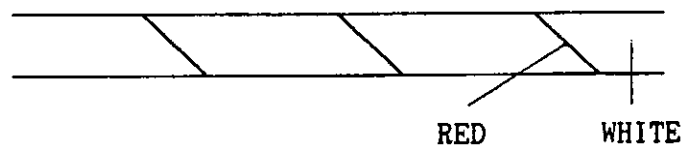

Note 1 : The character following the wire color code indicates the size of the wire.

K : A W G 18, U L

L : A W G 20, U L 1007

None: A W G 22, U L 1007

THIS PAGE INTENTIONALLY OMITTED

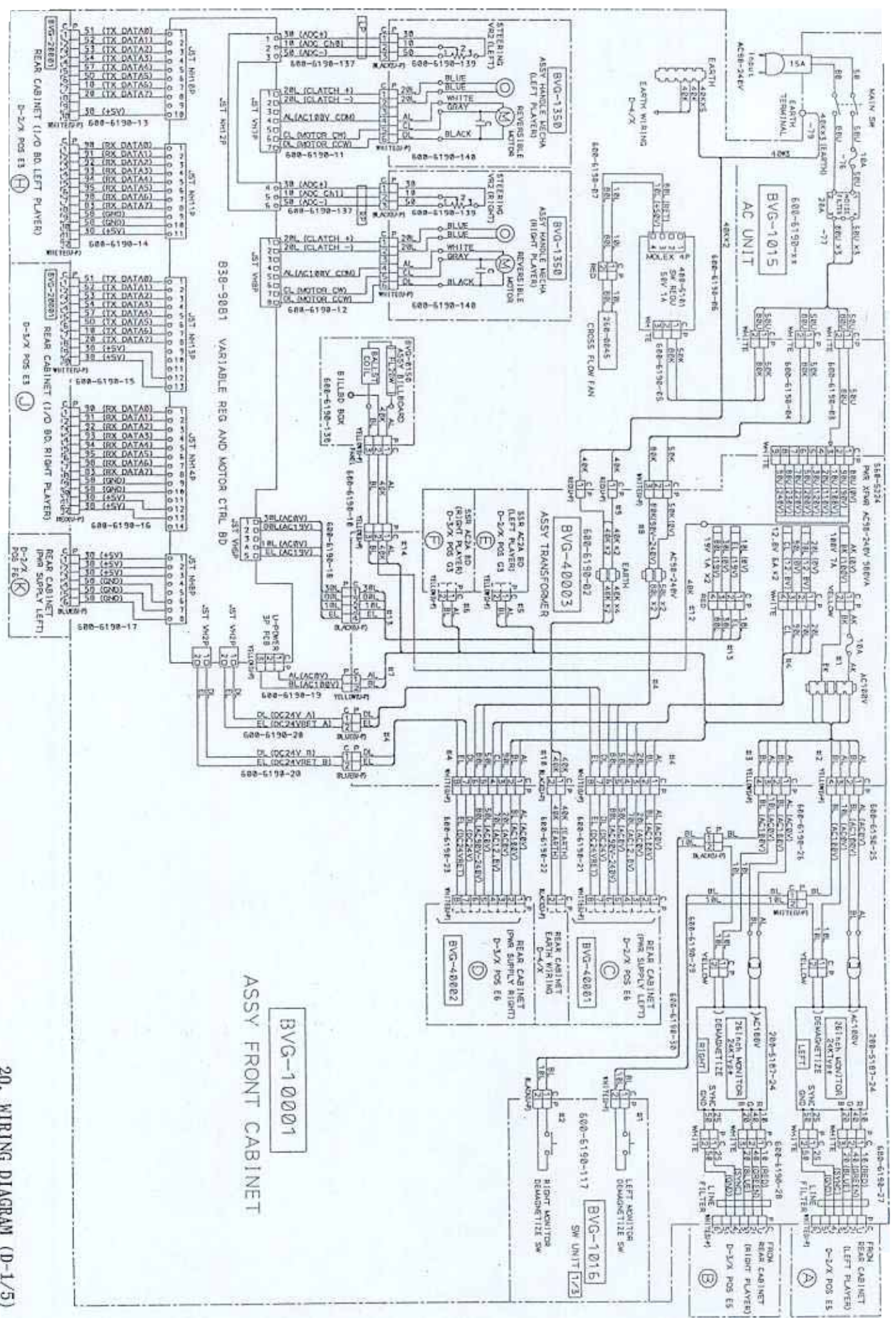

**ASSY FRONT CABINET**

20. WIRING DIAGRAM (D-1/5)







RIGHT PLAYER SIDE

