

1ST PRINTING  
JAN.- 1998

# SEGA™



***Harley-Davidson & L.A. Riders***

## OWNER'S MANUAL

STD TYPE



SEGA ENTERPRISES, USA



MANUAL NO. 4200-6367

## **Warranty**

Your new Sega Product is covered for a period of 90 days from the date of shipment. This certifies that the Printed Circuit Boards, Power Supplies and Monitor are to be free of defects in workmanship or materials under normal operating conditions. This also certifies that all Interactive Control Assemblies are to be free from defects in workmanship and materials under normal operating conditions. No other product in this machine is hereby covered.

Sellers sole liability in the event a warranted part described above fails shall be, at its option, to replace or repair the defective part during the warranty period. For Warranty claims, contact your Sega Distributor.

Should the Seller determine, by inspection that the product was caused by Accident, Misuse, Neglect, Alteration, Improper Repair, Installation or Testing, the warranty offered will be null and void.

Under no circumstances is the Seller responsible for any loss of profits, loss of use, or other damages.

This shall be the exclusive written Warranty of the original purchaser expressed in lieu of all other warranties expressed or implied. Under no circumstance shall it extend beyond the period of time listed above.

## TABLE OF CONTENTS

INTRODUCTION OF THE OWNERS MANUAL	1
GENERAL PRECAUTIONS	2~3
1. PRECAUTIONS TO BE HEDED FOR OPERATION	4~5
2. NAME OF PARTS	6
3. ACCESSORIES	7~8
4. ASSEMBLY AND INSTALLATION	9~14
5. PRECAUTIONS TO BE HEDED WHEN MOVING MACHINE	15
6. CONTENTS OF GAME	16~18
7. EXPLANATION OF TEST AND DATA DISPLAY	19~30
7-1 POWER SUPPLY UNIT AND COIN METER	20
7-2 TEST MODE	21
7-3 MEMORY TEST	21
7-4 VIDEO MEMORY TEST	22
7-5 BOUNDRY TEST	22
7-6 INPUT TEST	23
7-7 OUTPUT TEST	23
7-8 SOUND TEST	24
7-9 C.R.T. TEST	24
7-10 GAME ASSIGNMENTS	25
7-11 COIN ASSIGNMENTS	26~28
7-12 REAL TIME CLOCK TEST	29
7-13 VOLUME SETTING	29
7-14 NETWORK ASSIGNMENTS	29
7-15 BOOKKEEPING	30
7-16 BACKUP DATA CLEAR	30
8. HANDLEBAR	31
8-1 ADJUSTING/REPLACING THE FRONT BRAKE VOLUME	31
8-2 ADJUSTING/REPLACING THE ACCELERATOR VOLUME	32
8-3 ADJUSTING/REPLACING THE HANDLE BAR VOLUME	33~36
8-4 GREASING	37
9. FOOT BRAKE MECHA	38
9-1 ADJUSTING AND REPLACING THE VOLUME	38~39
9-2 GREASING	40
10. COIN SELECTOR	41~43
11. MONITOR	44~46
12. REPLACEMENT OF FLUORESCENT LAMP AND LAMPS	47~48
12-1 REPLACEMENT OF FLUORESCENT LAMP	47
12-2 REPLACEMENT OF LAMPS	48
13. PERIODIC INSPECTION TABLE	49
14. TROUBLESHOOTING	50
14-1 REPLACEMENT OF FUSES	51
15. GAME BOARD	52
15-1 REMOVING THE IC BOARD	52~53
15-2 COMPOSITION OF THE GAME BOARD	54
16. COMMUNICATION PLAY	55~65
16-1 INSTALLATION PRECAUTIONS	55
16-2 CONNECTING THE COMMUNICATION CABLES	55~63
16-3 SETTING FOR COMMUNICATION PLAY	64~65
17. DESIGN RELATED PARTS	66
18. PARTS LIST	67~94
19. WIRING DIAGRAMS	XXX

## SPECIFICATIONS

Installation space:	65 in.(L) x 31 in.(W)
Height:	78 in.
Weight:	Approx. 397 lbs.
Power maximum current:	5 Amp AC 120V 60 Hz
MONITOR:	29" INCH COLR MONITOR

## INTRODUCTION OF THE OWNERS MANUAL

---

SEGA ENTERPRISES, LTD., has for more than 30 years been supplying various innovative and popular amusement products to the world market. This Owners Manual is intended to provide detailed descriptions together with all the necessary installation, game settings and parts ordering information related to the HARLEY DAVIDSON U/R, a new SEGA product.

This manual is intended for those who have knowledge of electricity and technical expertise, especially in ICs, CRTs, microprocessors, and circuit boards. Read this manual carefully to acquire sufficient knowledge before working on the machine. Should there be a malfunction, non-technical personnel should under no circumstances touch the interior system. Should the need arise, contact our main office, or the closest branch office listed below.

### **SEGA ENTERPRISES, INC. (USA)**

#### **Customer Service**

45133 Industrial Drive

Fremont, CA 94538

Phone 650-802-1750

Fax 650-802-1754

7:30 am - 4:00 pm, Pacific Standard Time

Monday thru Friday

## General Precautions

---

**Follow Instructions:** All operating and use instructions should be followed.

**Attachments:** Do not use attachments not recommended by the product manufacturer as they may cause hazards.

**Accessories:** Do not place this product on an unstable cart, stand, tripod, bracket, or table. The product may fall, causing serious injury to a child or adult, and serious damage to the product. Use only with a cart, stand, tripod, bracket, or table recommended by the manufacturer, or sold with the product. Any mounting of the product should follow the manufacturer's instructions, and should use only mounting accessories recommended by the manufacturer.

**Moving the Product:** This product should be moved with care. Quick stops, excessive force, and uneven surfaces may cause the product to overturn.

**Ventilation:** Slots and openings in the cabinet are provided for ventilation, to ensure reliable operation of the product and to protect it from overheating; these openings must not be blocked or covered. The openings should never be blocked by placing the product in a built-in installation such as a bookcase or rack unless proper ventilation is provided or the manufacturer's instructions have been adhered to.

**Power Sources:** This product should be operated only from the type of power source indicated on the marking label. If you are not sure of the type of power supply to your location, consult your local power company. For products intended to operate from battery power or other sources, refer to the operating instructions.

**Grounding or Polarization:** This product is equipped with a three-wire grounding-type plug, a plug having a third (grounding) pin. This plug will only fit into a grounding-type power outlet. This is a safety feature. If you are unable to insert the plug into the outlet, contact your electrician to replace your obsolete outlet. Do not defeat the safety purpose of the grounding-type plug.

**Power Cord Protection:** Power-supply cords should be routed so that they are not likely to be walked on or pinched by items placed upon or against them, paying particular attention to cords at plugs, convenience receptacles, and the point where they exit from the product.

**Overloading:** Do not overload wall outlets, extension cords, or integral convenience receptacles as this can result in a risk of fire or electric shock.

**Object and Liquid Entry:** Never push objects of any kind into this product through openings as they may touch dangerous voltage points or short-out parts that could result in a fire or electric shock. Never spill liquid of any kind on the product.

**Servicing:** Do not attempt to service this product yourself as opening or removing covers may expose you to dangerous voltage or other hazards. Refer all servicing to qualified service personnel.

**Damage Requiring Service:** Unplug this product from the wall outlet and refer servicing to qualified service personnel under the following conditions:

- a) If the power cord or plug is damaged;
- b) If liquid has been spilled, or objects have fallen into the product;
- c) If the product has been exposed to rain or water;
- d) If the product does not operate normally when following the operating instructions. Adjust only those controls that are explained in the operating instructions. An improper adjustment of other controls may result in damage and will often require extensive work by a qualified technician to restore the product to its normal operation;
- e) If the product has been dropped or damaged in any way;
- f) When the product exhibits a distinct change in performance; this indicates a need for service.

**Replacement Parts:** When replacement parts are required, be sure the service technician has used replacements parts specified by the manufacturer or that have the same characteristics as the original part. Unauthorized substitutions may result in fire, electric shock, or other hazards.

**Safety Check:** Upon completion of any service or repairs to this product, ask the service technician to perform safety checks to determine that the product is in proper operating condition.

**Heat:** The product should be situated away from heat sources such as radiators, heat registers, stoves, or other products (including amplifiers) that produce heat.

**Lithium Battery-** Dispose of batteries only in accordance with the battery manufacturer's recommendations. Do not dispose in an open flame condition, since the battery may explode.

**Cleaning:** When cleaning the monitor glass, use water or glass cleaner and a soft cloth. Do not apply chemicals such as benzene, thinner, etc.

**Location:** This is an indoor game machine, DO NOT install it outside. To ensure proper usage, avoid installing indoors in the places mentioned below:

- Places subject to rain/water leakage, or condensation due to humidity;
- In close proximity to a potential wet area;
- Locations receiving direct sunlight;
- Places close to heating units or hot air;
- In the vicinity of highly inflammable/volatile chemicals or hazardous matter;
- On sloped surfaces;
- In the vicinity of emergency response facilities such as fire exits and fire extinguishers;
- Places subject to any type of violent impact;
- Dusty places.

#### **INSTALLATION PRECAUTIONS**

- Verify the amperage of the branch circuit outlet before plugging in the power plug. Do not overload the circuit.
- Avoid using an extension cord. If one is required, use an extension cord of type SJT, 16/3 AWG rated min. 120 VAC, 7A.
- Moving this unit requires a minimum clearance (of doors, etc.) of 32" (W) by 77" (H).
- For the operation of this machine, secure a minimum area of 32" (W) by 42" (D).

#### **REGULATORY APPROVALS**

This game has been tested and found to comply with the Federal Communications Commission Rules.

This device complies with Part 15 of the FCC Rules. Operation is subject to the following two conditions: (1) This device may not cause harmful interference, and (2) this device must accept any interference received, including interference that may cause undesired operation.

This game has been tested and listed by Underwriters Laboratories, Inc., to ANSI/UL22.

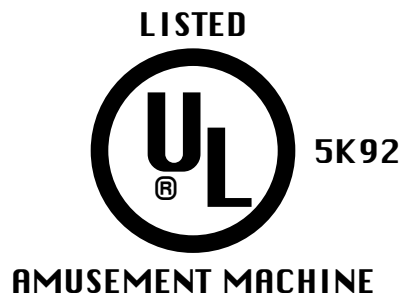

# 1 . PRECAUTIONS TO BE HEEDED FOR OPERATION

In order to prevent accidents, be sure to comply with the following points before and during operation.

## PRECAUTIONS TO BE HEEDED FOR OPERATION BEFORE STARTING THE OPERATION



- In order to avoid accidents, check the following before starting the operation:  
Check if all of the adjusters are in contact with the surface. If they are not, the cabinet can move and cause an accident.

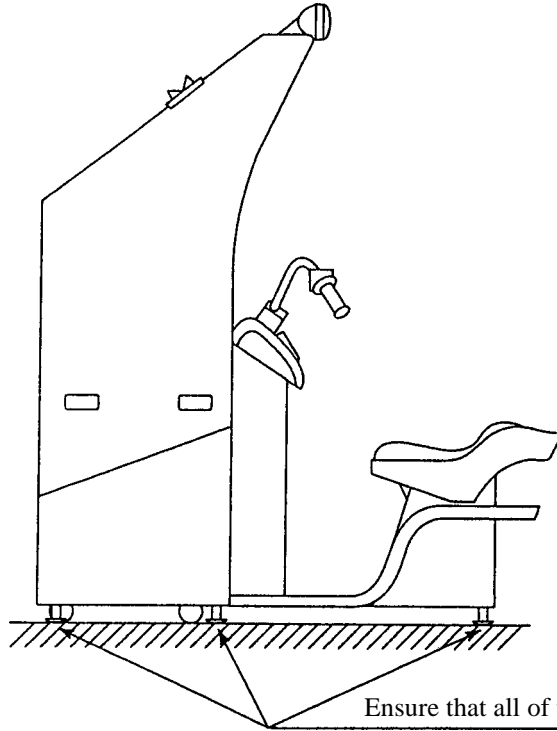

Ensure that all of the Adjusters  
are in contact with the floor.

- Do not climb on the product. Climbing on the product can cause falling down accidents. To check the top portion of the product, use a step.
- To avoid electric shock, check to see if door & cover parts are 508.5
- To avoid electric shock, short circuit and or parts damage, do not put the following items on or in the periphery of the product:
- Flower vases, flower pots, cups, water tanks, cosmetics, and receptacles/containers/vessels containing chemicals and water.



To avoid injury, be sure to provide sufficient space by considering the potentially crowded situation at the installation location. Insufficient installation space can cause the player to come into contact with or hit others and result in injury or trouble.

## PRECAUTIONS TO BE HEEDED DURING OPERATION



CAUTION!

To avoid injury and accidents, those who fall under the following categories are not allowed to play the game:

- \* Intoxicated persons
- \* Pregnant women or those in the likelihood of pregnancy.
- \* Those who need assistance such as the use of an apparatus when walking.
- \* Those who have high blood pressure or heart problems.
- \* Those who have experienced muscle convulsion or loss of consciousness when playing video games, etc.
- \* Persons susceptible to motion sickness.
- \* Persons whose acts run counter to the product's warning displays.
  
- \* Instruct those who wear high-heeled shoes to refrain from playing the game by explaining that playing the game with high-heeled shoes is very dangerous and likely to cause a potentially hazardous situation.



CAUTION!

To avoid electric shock and short circuit, do not allow customers to put hands and fingers or extraneous matter in openings of the product or small openings in or around doors.

To avoid falling down and injury resulting from falling down, immediately stop the customer's leaning against or climbing on the product, etc.

To avoid electric shock and short circuit, do not allow the customers to unplug the power plug without a justifiable reason.



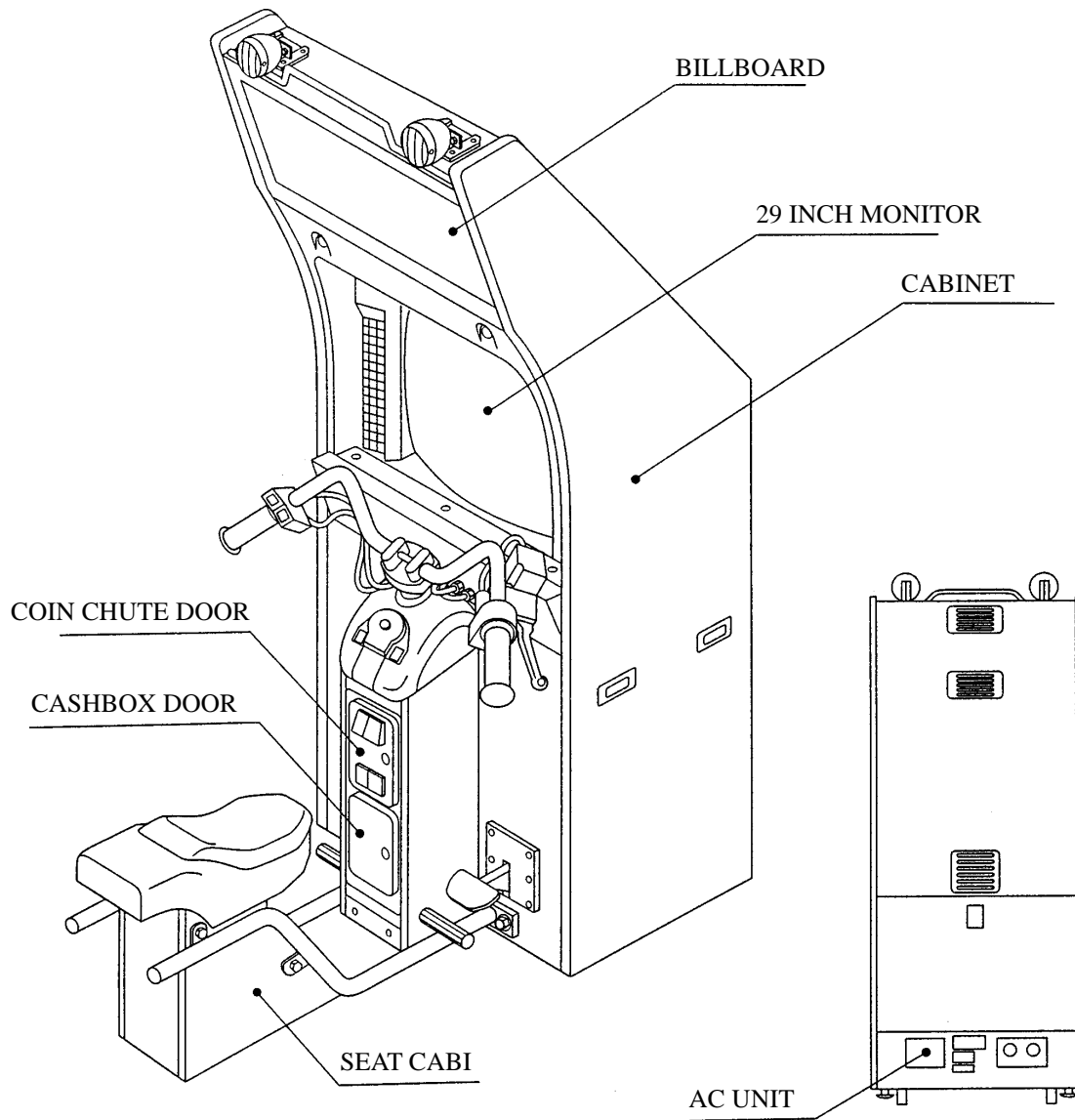

## 2 . NAME OF PARTS

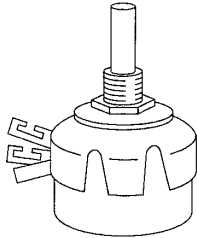
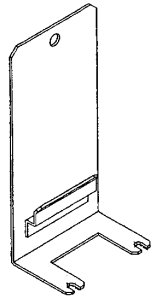
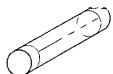

GAME SPECIFICATIONS	WIDTH	LENGTH	HEIGHT	WEIGHT
DURING SHIPPING	All measurements are in inches			475 LBS.
CABINET	31"	X 38"	X 78"	350 LBS.
SEAT CABI	13.5"	X 45.5"	X 25"	49 LBS.
WHEN ASSEMBLED	31"	X 65"	X 78"	400 LBS.

### 3 . ACCESSORIES

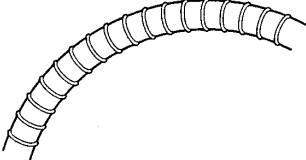
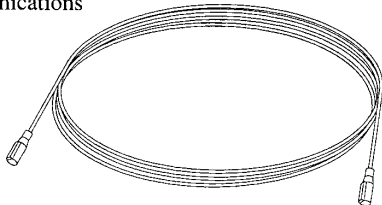
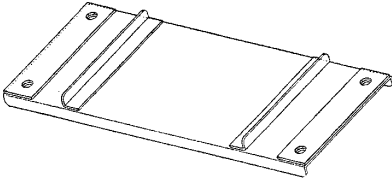
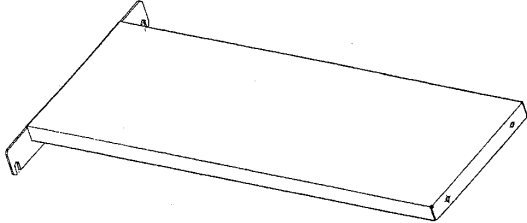
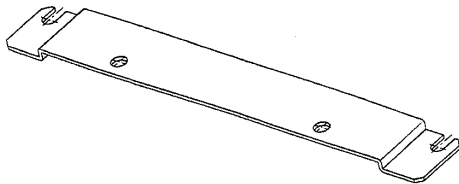
<p>DESCRIPTION OWNERS MANUAL          Part No. (Qty.) 4200-6367-01 (1)          Note          Figures          If Part No. has no description, the Number has not been registered or can not be registered. Such a part may not be obtainable even if the customer desires to purchase it. Therefore, ensure that the part is in safekeeping with you.</p>	<p>KEY MASTER          220-5576 (2)          For opening/closing the doors</p>	<p>KEY          (2)          For the CASHBOX DOOR</p>
<p>VOL CONT B-5K OHM          220-5484 (1)</p> 	<p>POP HOLDER          HLD-0004 (2)          For communications</p> 	
<p>FUSES          LOCAL PURCHASE</p> 	<p>POP PANEL          429-0162-91 (1)          For communications</p> 	
<p>CONN 29          310-5287-29 (1)          For communications</p> 	<p>FLEX TUBE          310-5285-290150 (1)          For communications</p> 	
<p>ASSY FIBER CABLE          600-6275-0500 (3)          For communications</p> 	<p>UPPER JOINT          HLD-0001 (1)          For communications</p> 	
<p>LOWER JOINT          HLD-0002 (1)          For communications</p> 	<p>JOINT PLATE          HLD-0003 (1)          For communications</p> 	



WARNING!

**THE SHIPMENT METHOD DESCRIBED BELOW ONLY APPLIES TO 'MODEL 3' BOARDS CONTAINED IN THE FOLLOWING GAMES:**

**LOST WORLD, VIRTUA FIGHTER 3, SUPER GT, SEGA BASS FISHING, STRIKER 2 HARLEY DAVIDSON**

**!!NEVER SHIP MODEL 3 GAME BOARDS OUTSIDE OF CAGE!!**

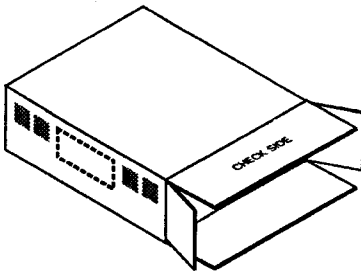

CARTON BOX  
601-8928 (1)  
Used for transporting the GAME BOARD.  
{SUPPLIED WITH YOUR GAME}

**DO NOT SHIP GAME BOARD WITHOUT THIS BOX AS IT MAY DAMAGE THE GAME BOARD AND VOID YOUR WARRANTY.**

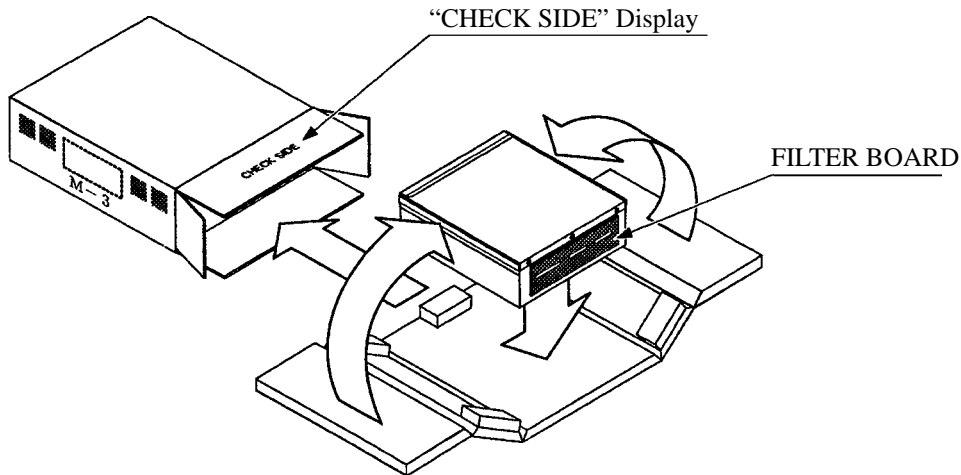

WARNING!

**NO OTHER GAMES BOARDS ARE TO BE SHIPPED IN THE CAGE AS THEY MAY BE DAMAGED BEYOND REPAIR. PLEASE SHIP THEM WITHOUT CAGE PROPERLY PROTECTED DURING SHIPPING.**

## 4 . ASSEMBLING AND INSTALLATION



WARNING!

Assembling should be performed as per this manual. Since this is a complex machine, erroneous assembling may cause damage to the machine, or malfunctioning to occur.  
When assembling, be sure to perform work by plural persons.  
Depending on the assembly work, there are some cases in which performing the work by a single person can cause personal injury or parts damage.

When carrying out the assembly work, follow the procedure in the following 7-item sequence:

- 1 ASSY OF CABINET
- 2 SECURING IN PLACE (ADJUSTER ADJUSTMENT)
- 3 POWER SUPPLY
- 4 ASSEMBLING CHECK

Note that the tools such as a phillips screwdriver and wrench for M16 hexagon bolt w/24 mm width across flats are required for the assembly work.



ASSY OF CABINET



CAUTION!

Ensure that the connectors are accurately connected. Incomplete connections can cause electrical shock or short circuit. Be careful not to damage wirings. Damaged wiring can cause short circuit or electrical shock.



WARNING!

To perform work safely and securely, be sure to prepare a step which is in a secure and stable condition. Not using a step or using an unstable step can cause a violent falling down accident.

- ① Tightly fit the seat cabi to the cabinet in a manner to insert it in.
- ② Secure to the cabinet with 2 hexagon bolts and 2 truss screws.
- ③ Connect the connector. (2P white)
- ④ Install the joint lid.
- ⑤ Secure the Joint lid with 4 screws.

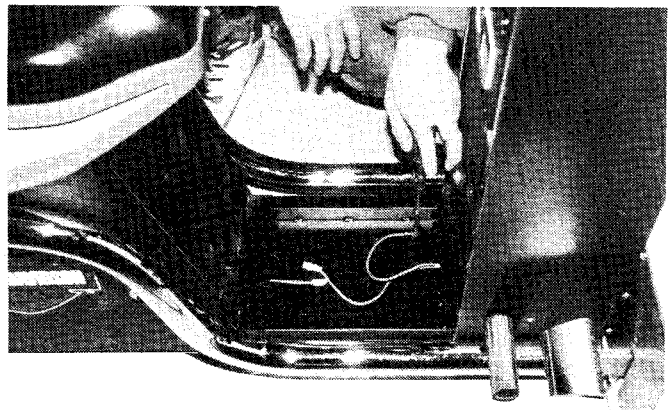
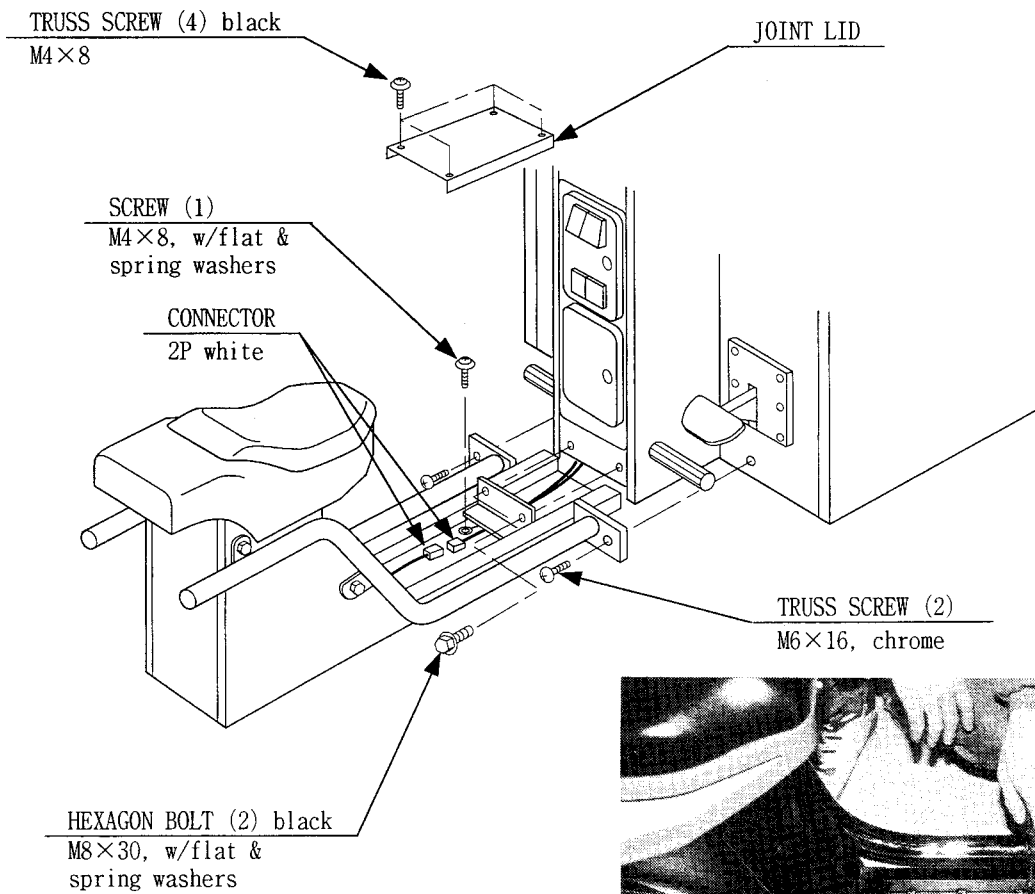

# 2

## SECURING IN PLACE (ADJUSTER ADJUSTMENT)



Be sure to have all the Adjusters make contact with the surface. Unless the Adjusters come into contact with the surface, the Cabinet can move of itself, causing an accident.

This machine has 8 each of casters and adjusters (shown below). When the installation position is determined, cause the adjusters to come into contact with the floor directly, make adjustments in a manner so that the casters will be raised approximately 5mm. from the floor and make sure that the machine position is level.

- ① Move the machine to the installation position.
- ② Cause all of the leg adjusters to make contact with the floor. By using a wrench, make adjustments in the height of the leg adjusters to ensure that the machine's position is level.
- ③ After making adjustments, fasten the leg adjuster nut upward and secure the height of the leg adjuster.
- ④ Depending on the floor surface status of the installation location, the Rear Cabinet may move of itself. As shown, the NON-SLIP SHEET is attached to the back side of the CAUTION MAT. Ensure that the Adjuster is installed in the manner to match the position of NON-SLIP SHEET
- ⑤ After making adjustments, fasten the adjuster nut upwards and secure the height of the adjuster

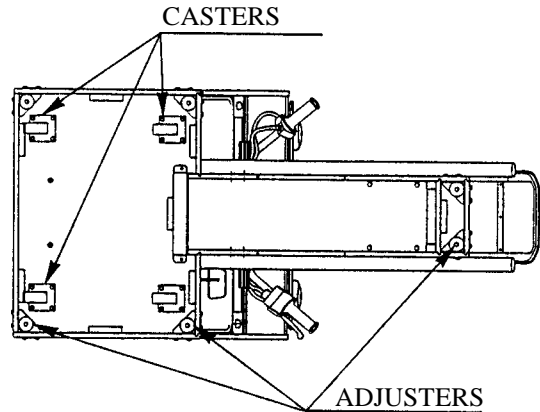

BOTTOM VIEW

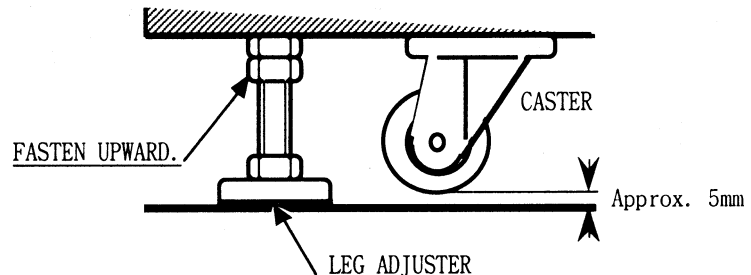

### 3 POWER SUPPLY



● Ensure that the power cord is not exposed on the surface (passage, etc.). If exposed, they can be caught and are susceptible to damage. If damaged, the cord can cause an electric shock or short circuit. Ensure that the wiring position is not in the customer's passage way or the wiring has protective covering.

The AC unit is mounted on the rear side of the cabinet . The AC Unit incorporates the Main SW, Earth Terminal and Inlet. Firmly insert the Power Plug into the Socket Outlet and the other side of the plug to the Inlet. Turn the Main SW ON to turn power ON.

① Ensure that the Main SW is OFF.

② Connect the Power cord to the Outlet Socket. Ensure power cord is not in customer's passage way or wiring has protective covering.

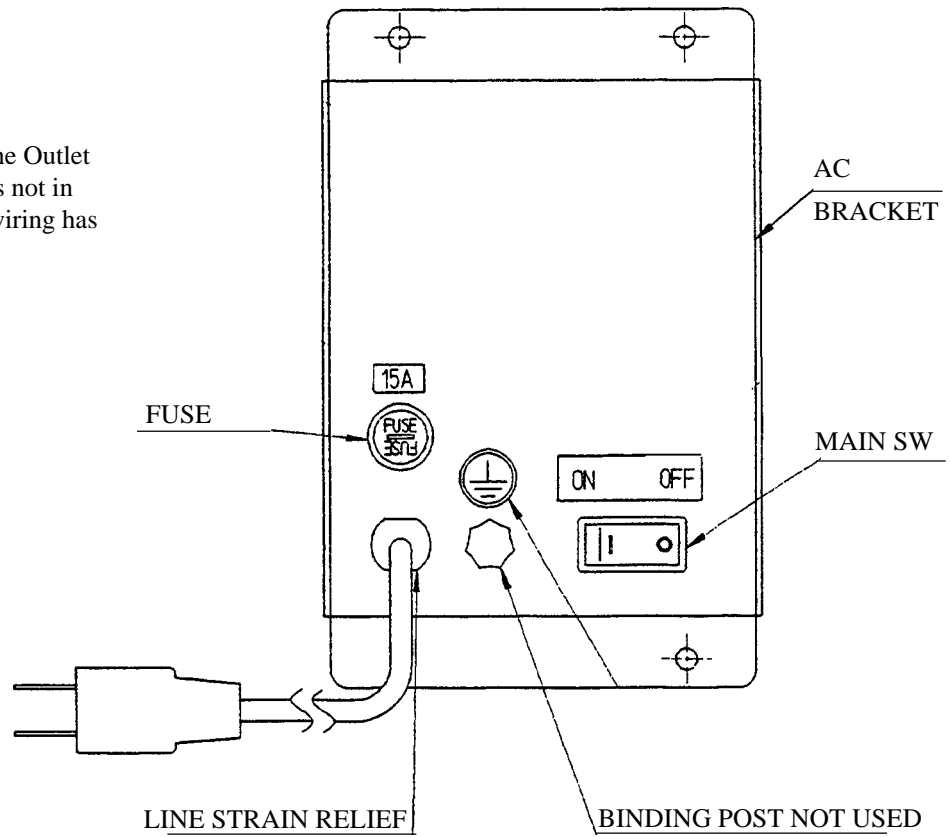

# 4

## ASSEMBLING CHECK

The TEST MENU allows for each part of the cabinet to be checked, the Monitor to be adjusted, and the coin and game related various functions to be performed.

CPU ROM TEST

GOOD	(CROM03 MASK)	IC.1	*****
GOOD	(CROM02 MASK)	IC.2	*****
GOOD	(CROM01 MASK)	IC.3	*****
GOOD	(CROM00 MASK)	IC.4	*****
GOOD	(CROM13 MASK)	IC.5	*****
GOOD	(CROM12 MASK)	IC.6	*****
GOOD	(CROM11 MASK)	IC.7	*****
GOOD	(CROM10 MASK)	IC.8	*****
GOOD	(CROM33 EPROM)	IC.9	*****
GOOD	(CROM32 EPROM)	IC.10	*****
GOOD	(CROM31 EPROM)	IC.11	*****
GOOD	(CROM30 EPROM)	IC.12	*****
GOOD	(CROM3 EPROM)	IC.13	*****
GOOD	(CROM2 EPROM)	IC.14	*****
GOOD	(CROM1 EPROM)	IC.15	*****
GOOD	(CROM0 EPROM)	IC.16	*****

PRESS TEST BUTTON TO EXIT

Selecting the MEMORY TEST on the test mode menu screen causes the on-board memory to be tested automatically. The game board is satisfactory if the display beside each IC No. shows GOOD.

INPUT TEST

HANDLEBAR	OFF
THROTTLE	OFF
FRONT BRAKE	OFF
REAR BRAKE	OFF
VIEW CHANGE	OFF
MUSIC SELECT	OFF
SHIFT UP	OFF
SHIFT DOWN	OFF
START	OFF
COIN #1	OFF
SERVICE-SW	OFF
TEST-SW	OFF

PRESS TEST BUTTON TO EXIT

Selecting the INPUT TEST on the menu screen in the test mode to display the screen on which each SW and Volume is tested. Press each switch. (To check the Coin SW, insert a Coin from the inlet with the Coin Chute Door being opened.) If the display beside each switch is ON, the switch and wiring connection are satisfactory. Check the display of each Volume value. The Volume could have an irregularity caused by differences between machines and vibration during transportation. Set the Volume values by referring to Section ?

OUTPUT TEST

START	LAMP	OFF
VIEW CHANGE	LAMP	OFF
MUSIC SELECT	LAMP	OFF
RACE READER	LAMP	OFF

>EXIT

SELECT WITH SERVICE BUTTON  
PRESS TEST BUTTON TO EXIT

In the output test mode, carry out lamp test to ascertain that each lamp lights up satisfactorily.



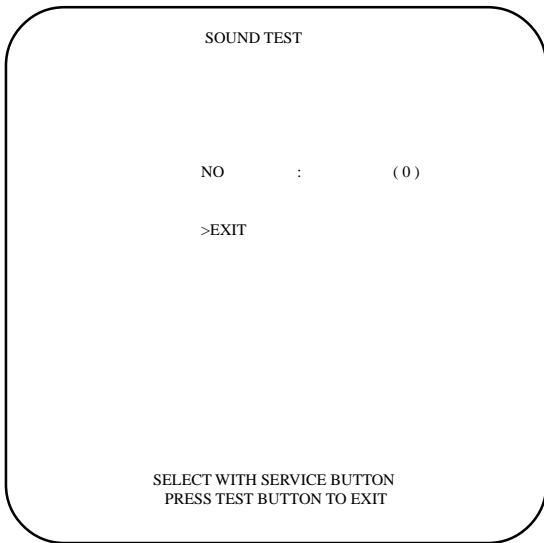

In the TEST mode, selecting SOUND TEST causes the screen, on which sound related BD and wiring connections are tested, to be displayed. be sure to check if the sound is satisfactorily emitted from each of speaker and the sound volume is appropriate.

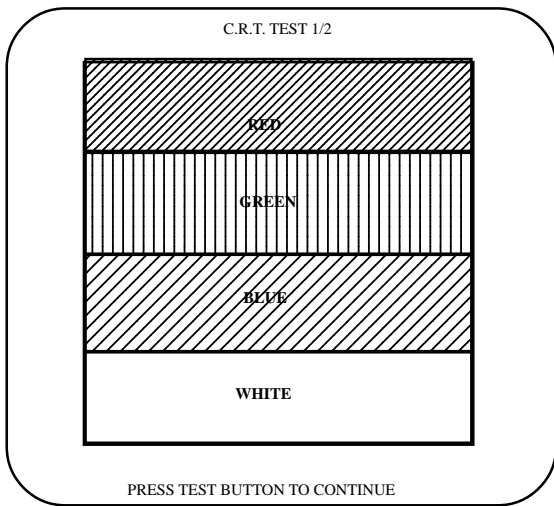

In the TEST mode menu, selecting C.R.T. TEST allows the screen (on which the projector is tested) to be displayed. Although the projector adjustments have been made at the same time of shipment from the factory, color deviation, etc., may occur due to the effect caused by geomagnetism, the location building's steel frames and other game machines in the periphery. By watching the test mode screen, make judgement as to whether an adjustment is needed. If it is necessary, adjust the projector by referring to Section 9.

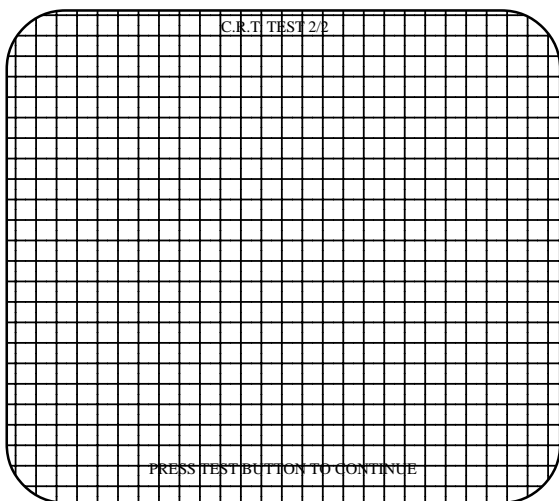

Perform the above inspections also at the time of monthly inspection.

## 5 . PRECATIONS TO BE HEEDED WHEN MOVING THE MACHINE



WARNING!

- When moving the machine, be sure to pull out the plug from the power supply. Moving the machine with the plug as is inserted can damage the power cord and cause a fire or electric shock.
- When moving the machine on the floor, retract the Adjusters and ensure that Casters make contact with the floor. During transportation, pay careful attention so that Casters do not tread power cords. Damaging the power cords can cause an electric shock and/or short circuit.
- When lifting the cabinet, be sure to hold the catch portions or bottom part. Lifting the cabinet by holding other portions can damage parts and installation portions, due to the empty weight of the cabinet, and cause personal injury.



CAUTION!

Use care when handling glass made parts. When the glass is damaged, fragments of glass can cause injury

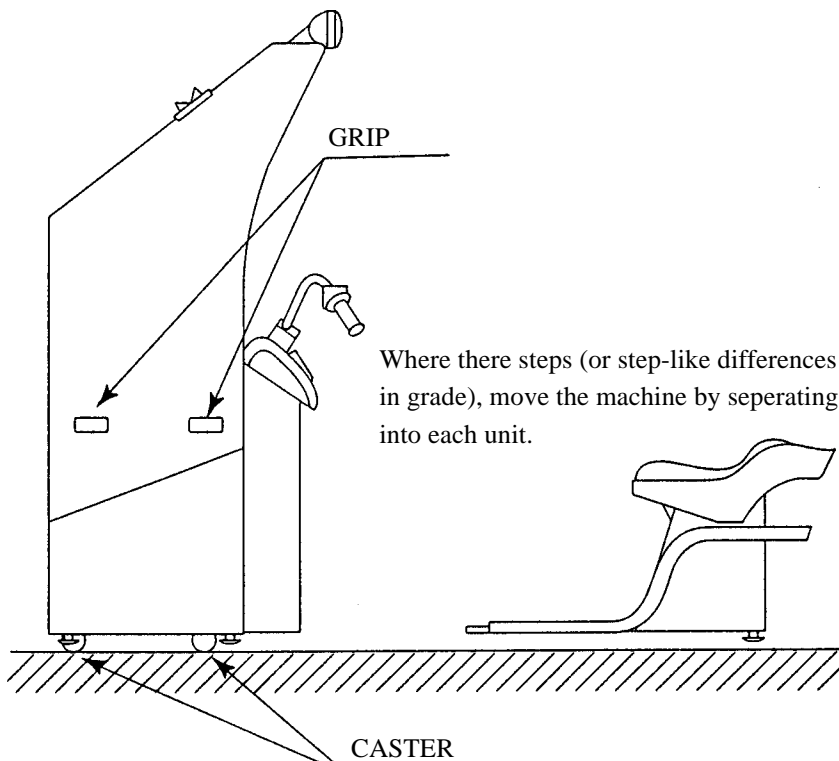

Where there steps (or step-like differences in grade), move the machine by seperating into each unit.

CASTER

On level surfaces, move the machine by causing the casters to make contact with the surfaces.

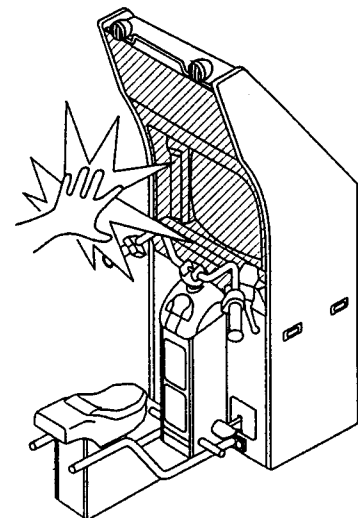

Pushing the glass made or plastic parts can damage the parts and cause injury. Also, moving machine by holding the handlebar can damage the handle bar.

## 6 . CONTENTS OF GAME

The following are operations and responses obtained when the machine functions satisfactorily. Any functioning different from the following may have been caused by a certain fault. Immediately investigate and eliminate the cause of the malfunctioning to ensure satisfactory operation. The explanation herein mainly refers to the case where the game machine is used independently. In communications play, some points may differ from the following explanations.

When energized, the Billboard's fluorescent lamp is always lit.

During ADVERTISE (in the status a coin(s) is not inserted), the contents of game and HOW TO PLAY, etc., are audio-visually explained.

The status of the on-tank 3 buttons will change to and from lighting up/flashing/lights out.

Although the Start button is unlit during ADVERTISE, it blinks if even one coin is inserted, and is always lit during game play.

The View Change button and Music Select button are unlit during ADVERTISE and lit when the Select Mode is displayed. During Game, the flash alternately.

The two lamps of the Billboard flash during ADVERTISE and Select Mode display, light up during game and flash for approximately 3 seconds at the time of passing the checkpoint.

In case of communication play, the lamps light up during game, flash for approximately 3 seconds when passing the checkpoint (in top position), and light out for 3 seconds when passing the checkpoint (in the second position or lower).

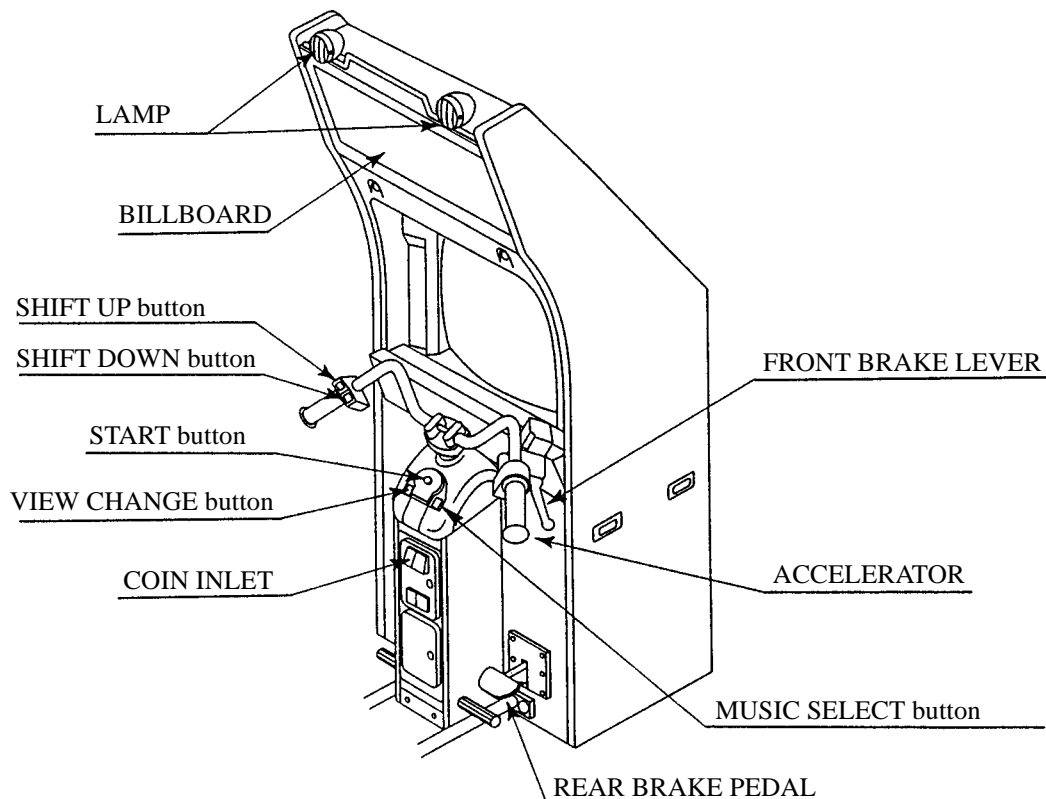

- ① Be seated.
- ② Insert coin(s). When one play worth of coin(s) is inserted, the Select mode appears.
- ③ Select in order of BIKE and TRANSMISSION. Turn the handlebar to select and turn the ACCELERATOR GRIP to decide.

When the Select Mode is displayed, countdown starts. At count 0, BIKE TRANSMISSION being selected are automatically decided.

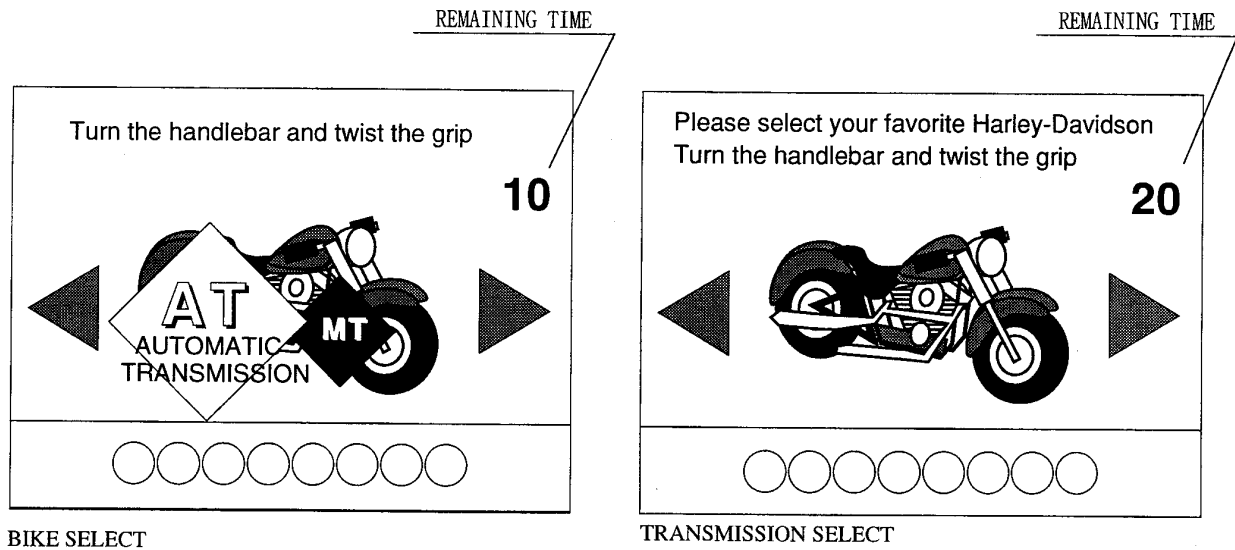

- ④ When TRANSMISSION is decided, the race starts. The checkpoint (desination) is displayed on the screen, and Time Limit countdown starts.

At the same time the race starts, the View Change button and Music Select button alternately light up/light out. Pressing the View Change button changes the View point in the game mode. Pressing the Music Select button changes the BGM (background music).

- ⑤ The distance to the checkpoint is displayed on the upper left section of the screen. the remaining time is indicated on the upper center, score points on the upper right, navigation window(map) on the lower left, and speedometer on the lower right.

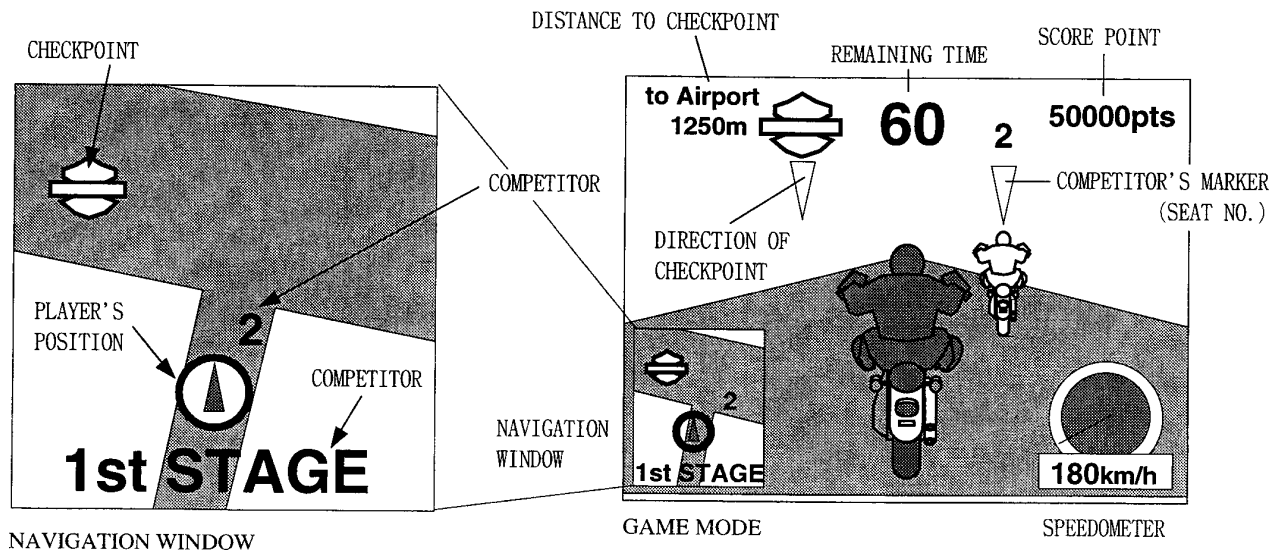

- ⑥ Run towards the checkpoint by judging the route from the arrow and the NAVIGATION WINDOW. Passing the checkpoint within the time limit results in a Stage Clear. The time limit is extended and the next checkpoint is displayed.
- ⑦ If the player fails to pass the checkpoint within the time limit, the game is over.
- ⑧ Passing all of the checkpoints results in a Game Clear. The successful player can see the ending mode.
- ⑨ After a Game Over, the accomplishment results are displayed on the map.
- ⑩ If the player scores high points, the Name Entry mode appears. Turn the Handlebar, select character, and turn the Accelerator Grip to register initial, etc.

NOTE 1:

Setting change can be made to no sound output during ADVERTISE.

NOTE 2:

In the case where several machines are linked together for communication play, the bike appearing first in the Select Mode is predetermined by the number of each cabinet set for the communication play.

NOTE 3:

The setting of the number of checkpoints required for game clear is changeable.

KNACK OF GAME PLAY

To make full use of bike characteristics;

Each of the 5 types of bike has specific characteristics. High points can be earned by fully utilizing the bike characteristics and selecting the type which suites best for the player.

To memorize the courses;

The player will surely accomplish a game clear by selecting the course on which he can make full use of the bike characteristics instead of relying on the map and arrow.

## 7 . EXPLANATION OF TEST AND DATA DISPLAY

By operating the switch unit, periodically perform the tests and data check. When installing the machine initially or collecting cash, or when the machine does not function correctly, perform checking in accordance with the explanations given in this section. The following shows tests and modes that should be utilized as applicable.

TABLE 7 EXPLANATION OF TEST MODE

ITEMS	DESCRIPTION	SECTIONS
INSTALLATION OF MACHINE	When the machine is installed, perform the following: 1. Check to see that each setting is as per standard setting made at the time of shipment. 2. In the INPUT TEST mode, check each SW and VR. 3. In the OUTPUT TEST mode, check each of lamps. 4. In the MEMORY TEST mode, check ICs on the IC Board.	7 - 10, 7 - 11  7 - 6  7 - 7  7 - 3, 7 - 4
MEMORY	Choose MEMORY TEST in the MENU mode to allow the MEMORY test to be performed. In this test, PROGRAM RAMs, ROMs, and ICs on the IC Board are checked.	
PERIODIC SERVICING	Periodically perform the following: 1. MEMORY TEST 2. Ascertain each setting. 3. In the INPUT TEST mode, test the CONTROL device 4. In the OUTPUT TEST mode, check each of lamps.	7 - 3, 7 - 4  7 - 10, 7 - 11  7 - 6  7 - 7
CONTROL SYSTEM	1. In the INPUT TEST mode, check each SW and VR. 2. Adjust or replace each SW and VR. 3.If the problem can not be solved yet, check the CONTROL's moves.	7 - 6  8  8
PROJECTOR	In the PROJECTOR ADJUSTMENT mode, check to see if the PROJECTOR adjustment is appropriately made.	7 - 9
IC BOARD	1. MEMORY TEST 2. In the SOUND TEST mode, check the sound related ROMs.	  7 - 8
DATA CHECK	Check such data as game play time and histogram to adjust the difficulty level, etc	7 - 15

## 7 - 1 SWITCH UNIT AND COIN METER



Never touch places other than those specified. Touching places not specified can cause electric shock and short circuit.



- Adjust to the optimum sound volume by considering the environmental requirements of the installation location.
- If the COIN METER and the game board are electrically disconnected, game play is not possible.

Open COIN CHUTE DOOR, and the switch unit shown appears. The function of each switch is as follows:

### SWITCH UNIT

- 1 SOUND VOLUME**  
Controls the speaker volume of the right/left speakers on the coin chute tower.
- 2 TEST BUTTON (TEST SW)**  
For the handling of the TEST BUTTON, refer to the section on test mode.
- 3 SERVICE BUTTON (SERVICE SW)**  
Gives credits without registering on the coin meter.

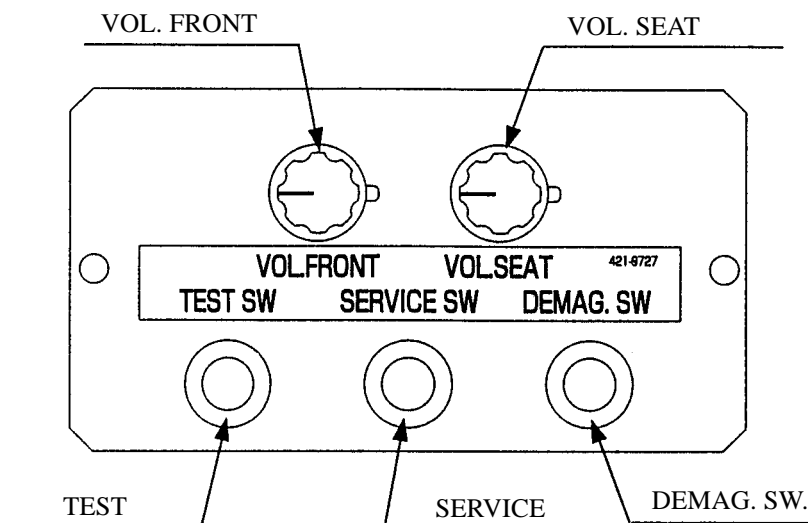

## 7 - 2 TEST MODE

This mainly checks if the operation of the game BD is accurate, and allows for COIN ASSIGNMENTS/GAME ASSIGNMENTS setting and Projector adjustments.

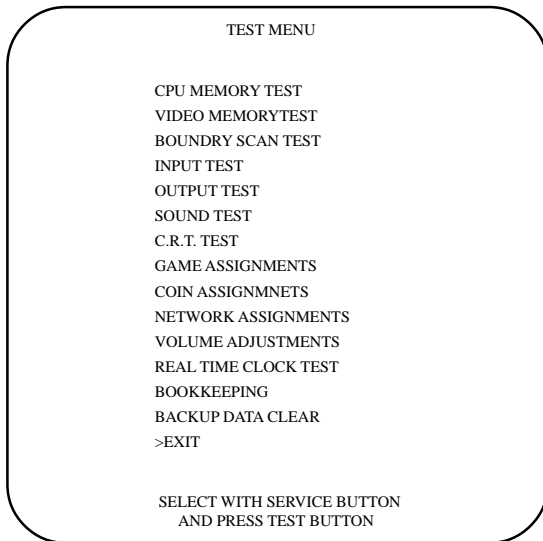

- ① Push the TEST BUTTON to cause the following TEST MENU to appear:
- ② By pushing the SERVICE BUTTON, bring the “>” mark to the desired item and press the TEST BUTTON. This will select the item’s test.
- ③ After the test is complete, move the “>” mark to “EXIT” and press the TEST BUTTON to return to game mode.

FIG. 7.2 TEST MENU

The Following FIGURES/TABLES show the factory recommended settings.

## 7 - 3 MEMORY TEST

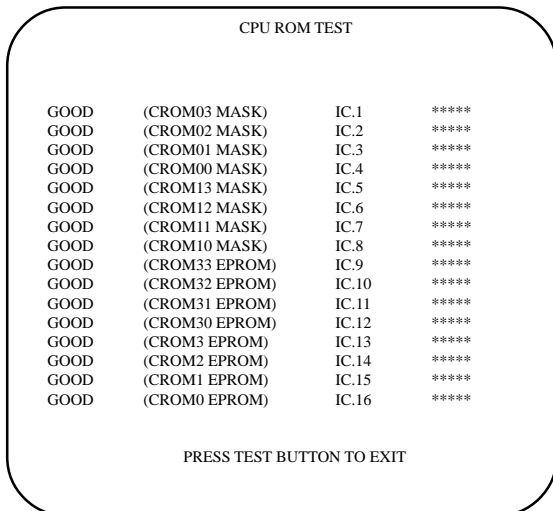

FIG. 7.3a MEMORY TEST

The MEMORY TEST mode is for checking the on-BD memory IC functioning.

“GOOD” is displayed for normal ICs and “BAD” is displayed for abnormal ICs

This test starts immediately after selection from the menu in the test mode. When in execution, the “TESTING NOW” message will be displayed at the lower part to the screen. Press the Test Button to proceed to CPU RAM TEST

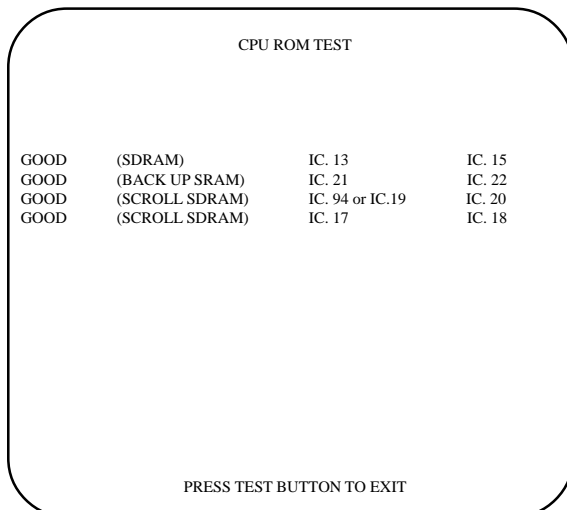

FIG. 7.3b MEMORY TEST

Test starts immediately after proceeding to this mode from CPU ROM TEST. During execution, the “TESTING NOW” message will be displayed at the lower part of the screen. When an error occurs, the ERROR message is shown. After finishing the test, press the TEST button to return to the menu mode.



## 7 - 4 VIDEO MEMORY TEST

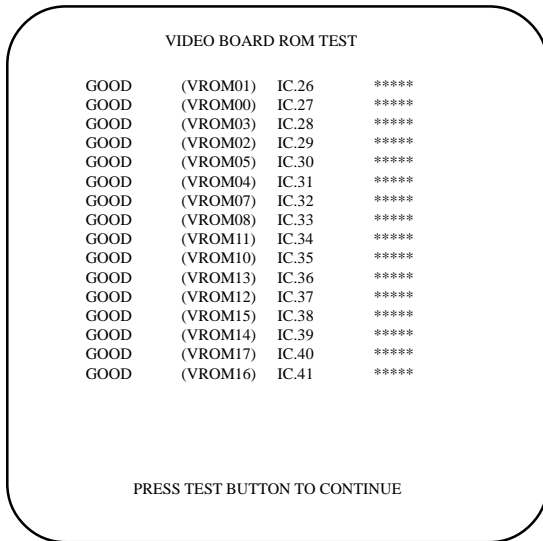

FIG. 7.4a VIDEO MEMORY TEST

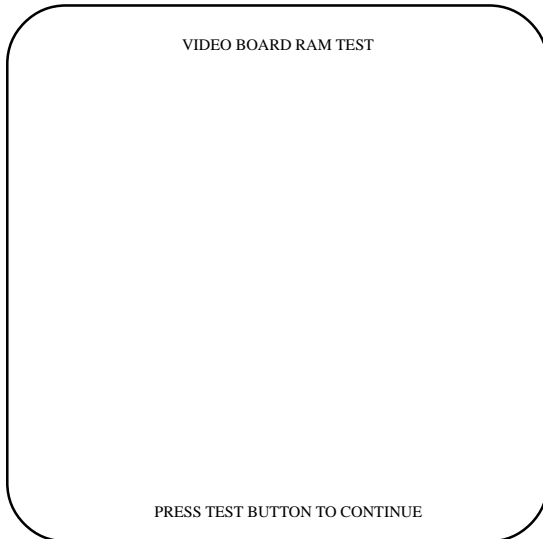

FIG. 7.4b VIDEO MEMORY TEST

## 7 - 5 BOUNDRY SCAN TEST

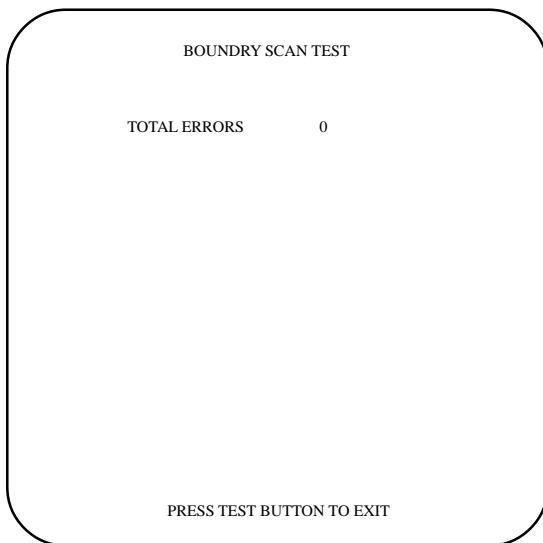

FIG. 7.5 BOUNDRY SCAN TEST

This allows the functioning of the VIDEO MEMORY IC's on the IC board to be checked. "GOOD" is displayed for normal IC's and "BAD" is displayed for abnormal IC's if any.

Test starts immediately after proceeding to this mode from the menu in the test mode. During execution, the "TESTING NOW" message will be displayed at the lower portion of the screen. After finishing the test, press the TEST BUTTON to proceed to VIDEO RAM.

Test starts immediately after proceeding to this mode from the VIDEO BOARD ROM TEST. During execution, the "TESTING NOW" message will be displayed at the lower portion of the screen. If status is satisfactory, nothing will be displayed. After finishing the test, press the TEST BUTTON to return to the menu mode.

Selecting the "BOUNDRY SCAN TEST" causes the Game board's testing in terms of hardware to be performed automatically.

- When the test is completed, if the results are as shown left, it is satisfactory.
- After finishing the test, press the TEST BUTTON to have the MENU MODE return on the screen. Next, turn power off and then turn it back on again. To avoid malfunctioning, have the Board initialized by turning the power off and then on.
- If there is any hardware problems, an error message is displayed. Please contact the offices herein stated or where the product was purchased from.

## 7 - 6 INPUT TEST

When INPUT TEST is selected, the MONITOR will show the following, allowing you to watch the status of each switch and the value of each V.R.

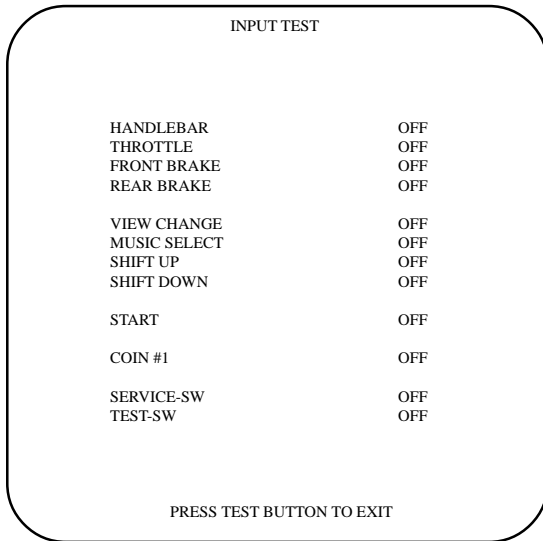
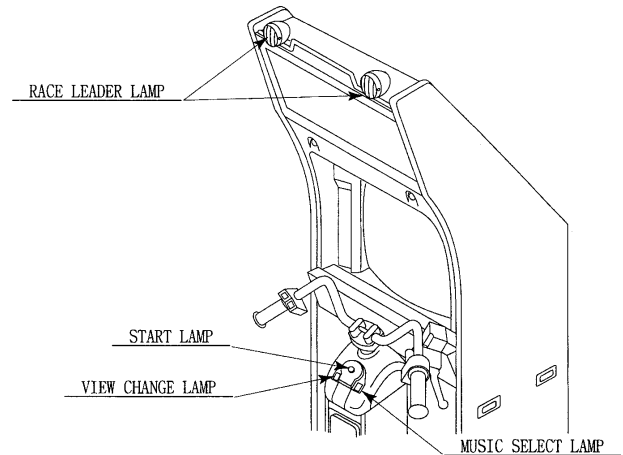
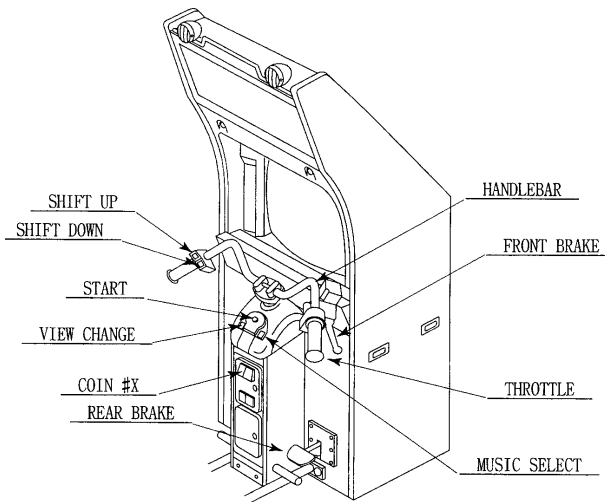

FIG. 7.6 INPUT TEST



- This test mode displays the status of each switch, button, and Volume. When the switch/button corresponds to the name of the item is pressed, if OFF changes to ON, it is satisfactory. When corresponding Volume is operated, if the Volume value differs in a natural manner, it is satisfactory.

### APPROPRIATE VALUE OF TENSION VOLUME

- Tension volume values are displayed in hexadecimal numerals within the range of 00H~ffH. If the value does not satisfy the following limitations, adjust the Volumes gear mesh so as to meet the requirements.

LOWER LIMIT: Over 05H

UPPER LIMIT: Under faH

- Press the test button to return to the menu mode

## 7 - 7 OUTPUT TEST

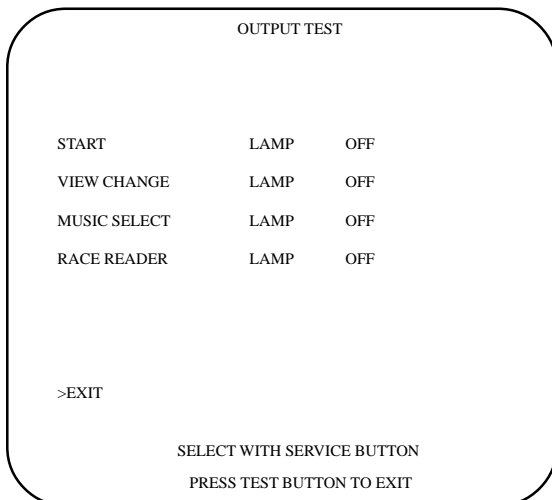

FIG. 7.7 OUTPUT TEST

Choose OUTPUT TEST to cause the following lower screen to appear. In this test, check the status of each lamp.

- Pressing the TEST BUTTON causes "ON" to be displayed and the corresponding lamp lights up. Pressing the TEST BUTTON again causes "OFF" to be displayed and the lamp goes off. The Foot Controller is locked with the Slide Lock in the ON status, and Unlocked to become free with the Slide Lock in the OFF status.
- Press the test Button to return to the MENU MODE.

## 7 - 8 SOUND TEST

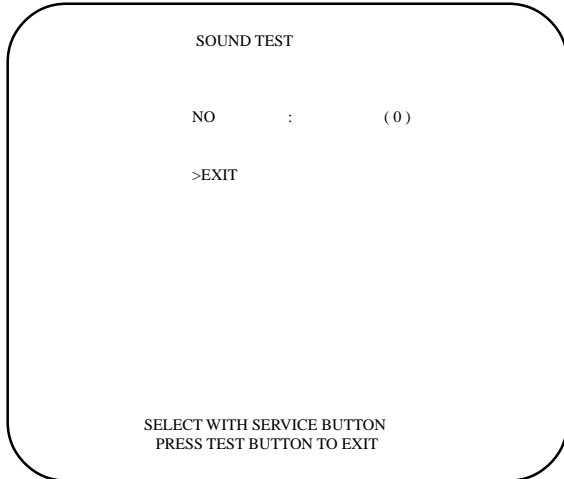
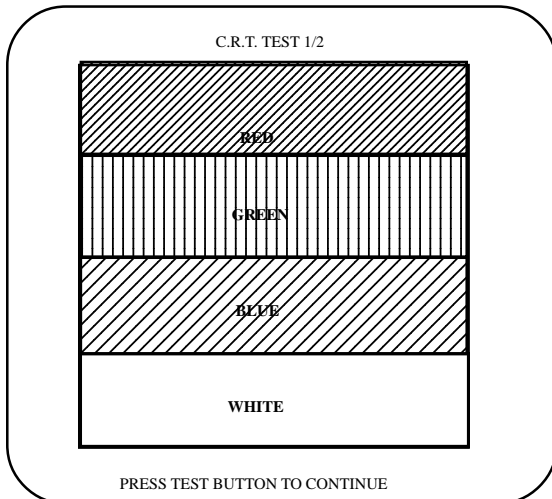

FIG. 7.8 SOUND TEST

This enables sound used in the game to be checked. Sound related memory and each speaker are checked.

- Press the SERVICE BUTTON to increase the number by one and the sound corresponding to the number will be emitted. Note that No. 000 does not emit any sound.
- Bring the ">" to EXIT and press the TEST BUTTON to return to the MENU MODE.

## 7 - 9 C.R.T. TEST



- Select C.R.T. TEST to cause the MONITOR to display the screen shown left, allowing MONITOR adjustment status to be checked.
- Periodically check the MONITOR adjustment status on this screen.
- The screen (1/2) enables color adjustment check to be performed. The color bar of each of the 4 colors, i.e., red, green, blue, and white, is the darkest at the extreme left and becomes brighter towards the extreme right.
- Press the TEST BUTTON to shift to the next screen (2/2).
- The screen (2/2) allows screen size and distortion to be tested.
- Check if the CROSSHATCH FRAME LINE goes out of the screen and if the crosshatch lines are distorted.
- Press the TEST BUTTON to return to the MENU mode.

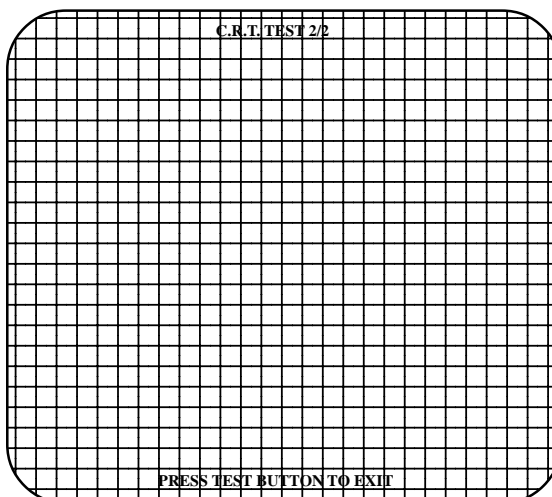

FIG. 7.9 C.R.T. TEST

## 7 - 10 GAME ASSIGNMENTS

Selecting the GAME ASSIGNMENTS in the MENU mode causes the present game settings to be displayed and also the game settings changes (game difficulty, etc.) can be made. Each item displays the following content.

### SETTING CHANGE PROCEDURE



IMPORTANT!

Setting changes cannot be stored unless the TEST BUTTON is pressed while the arrow is on EXIT.

- ① Press the SERVICE BUTTON to move the “>” to the desired item.
- ② Choose the desired setting change item by using the TEST BUTTON.
- ③ To return to the MENU mode, move the arrow to EXIT and press the TEST BUTTON.

GAME ASSIGNMENTS	
ADVERTISE SOUND	ON
GAME DIFFICULTY	NORMAL
CABINET TYPE	STANDARD
B.G.M. VOLUME	4
ENGINE VOLUME	8
NUMBER OF STAGES	4
TOURNAMENT MODE	ON
START	
MONTH	DEC
DAY	25
YEAR	1998
HOUR	18
END	
MONTH	DEC
DAY	25
YEAR	1998
HOUR	18
DURATION DAILY	
> EXIT	
SELECT WITH SERVICE BUTTON AND PRESS TEST BUTTON	

- **ADVERTISE SOUND**  
Determines whether ADVERTISE SOUND is to be emitted or not by the setting to ON when emitting it and to OFF when not emitting it.
- **GAME DIFFICULTY**  
Sets the Game Difficulty in 5 categories from 1 to 8. The greater the number is, the higher the difficulty level becomes. Alternately it may display each category by name; Very Easy, Easy, Normal, Hard, Very Hard
- **B.G.M. VOLUME**  
BGM Volume Adjustment.
- **ENGINE VOLUME**  
Engine Volume adjustment
- **CABINET TYPE**  
Set to DELUXE or STANDARD as applicable. Setting to wrong type can cause failure be sure to set correctly. (i.e. In communication Play Race Leader Lamp does not light up/flash/light out. The Cabinet appearing in the operation explanation mode differs from the type used.)
- **TOURNAMENT MODE**  
During the period set, special bookkeeping for ranking is executed. When set to ON, as shown above, the date of Tournament Mode Start, the end date of Tournament Mode, and times of bookkeeping periods are displayed. Duration refers to the unit of bookkeeping periods. The setting can be selected from among DAILY, WEEKLY, BI-WEEKLY, and MONTHLY. Be sure to set the present time in the Tournament Mode.

The Following FIGURES/TABLES show the factory recommended settings.

## 7 - 11 COIN ASSIGNMENTS

The “COIN ASSIGNMENTS” mode permits you to set the start number of credits, as well as the basic numbers of coins and credits. This mode expresses “how many coins correspond to how many credits.”

### SETTING CHANGE PROCEDURE



IMPORTANT!

Setting changes cannot be stored unless the TEST BUTTON is pressed while the arrow is on EXIT.

- ① Press the SERVICE BUTTON to move the arrow to the desired item.
- ② Choose the desired setting change item by using the TEST BUTTON.
- ③ To return to the MENU mode, move the arrow to EXIT and press the TEST BUTTON.

COIN ASSIGNMENTS			
COIN CHUTE TYPE	COMMON		
CREDIT TO START	2 CREDITS		
CREDIT TO CONTINUE	1 CREDIT		
COIN/CREDIT SETTING #1			
CHUTE#1	1 COIN	1 CREDIT	
CHUTE#2	1 COIN	1 CREDIT	
MANUAL SETTING			
>EXIT			
SELECT WITH SERVICE BUTTON AND PRESS TEST BUTTON			

- **COIN CHUTE TYPE**  
Sets the combination of the number of COIN CHUTES and the number of players as applicable. In the case that the COIN CHUTE is changed, be sure the setting is made in a manner meeting the replaced coin chute.

**COMMON:**  
Coins are accepted in common for both players.

**INDIVIDUAL:**  
Each player uses a coin chute which accepts coins independently.

- **CREDIT TO START**  
Number of credits required for starting game (1~5 credits are selected.)
- **CREDIT TO CONTINUE**  
Number of credits required for continuing game (1~5 credits are selected.)
- **COIN/CREDIT SETTING**  
Sets the CREDITS increase increment per coin insertion. There are 27 settings from #1 to #27, expressed in XX CREDIT as against XX COINS inserted. (TABLE 7.11a, 7.11b) #27 refers to FREE PLAY.  
When the COIN CHUTE TYPE is set to INDIVIDUAL, there are some setting numbers not displayed as indicated in TABLE 7.11b.
- **MANUAL SETTING**  
This allows credit increase setting as against coin insertion to be further set in the manner finer than COIN/CREDIT SETTING (refer to TABLE 7.11c).

TABLE 7.11a COIN/CREDIT SETTING (COIN CHUTE COMMON TYPE)

SETTING	FUNCTIONING OF CHUTE#1	
SETTING #1	1 COIN	1 CREDIT
SETTING #2	1 COIN	2 CREDITS
SETTING #3	1 COIN	3 CREDITS
SETTING #4	1 COIN	4 CREDITS
SETTING #5	1 COIN	5 CREDITS
SETTING #6	1 COIN	2 CREDITS
SETTING #7	1 COIN	5 CREDITS
SETTING #8	1 COIN	3 CREDITS
SETTING #9	1 COIN	4 CREDITS
SETTING #10	1 COIN	5 CREDITS
SETTING #11	1 COIN	6 CREDITS
SETTING #12	2 COINS	1 CREDIT
SETTING #13	1 COIN	1 CREDIT
SETTING #14	1 COIN	2 CREDITS
SETTING #15	1 COIN	1 CREDIT
	2 COINS	3 CREDITS
SETTING #16	1 COIN	3 CREDITS
SETTING #17	3 COINS	1 CREDIT
SETTING #18	4 COINS	1 CREDIT
SETTING #19	1 COIN	1 CREDIT
	2 COINS	2 CREDITS
	3 COINS	3 CREDITS
	4 COINS	5 CREDITS
SETTING #20	1 COIN	5 CREDITS
SETTING #21	5 COINS	1 CREDIT
SETTING #22	1 COIN	2 CREDITS
SETTING #23	2 COINS	1 CREDIT
	4 COINS	2 CREDITS
	5 COINS	3 CREDITS
SETTING #24	1 COIN	3 CREDITS
SETTING #25	1 COIN	1 CREDIT
	2 COINS	2 CREDITS
	3 COINS	3 CREDITS
	4 COINS	4 CREDITS
	5 COINS	6 CREDITS
SETTING #26	1 COIN	1 CREDITS
SETTING #27	FREE PLAY	

# MANUAL SETTING

Selecting MANUAL SETTING in the COIN ASSIGNMENTS mode displays the following screen.

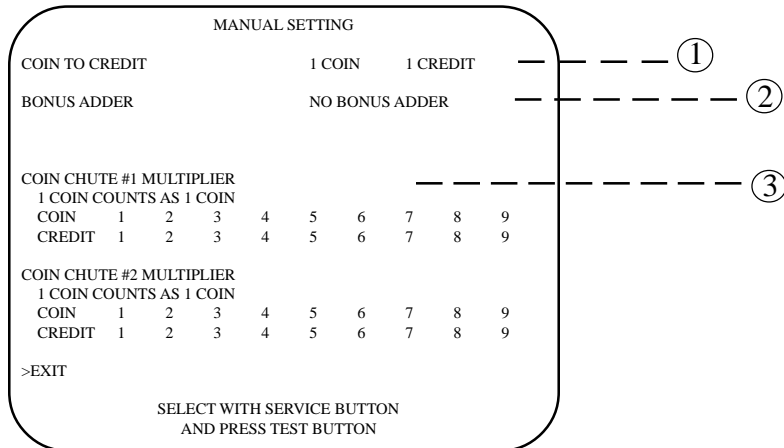

FIG. 7.11b MANUAL SETTING

- ① Determines Coin/Credit setting.
- ② This sets how many coins should be inserted to obtain one Service Coin.
- ③ This sets how many tokens one coin represents.

Table 7.11c MANUAL SETTING

COIN TO CREDIT	1 COIN	1 CREDIT
	2 COINS	1 CREDIT
	3 COINS	1 CREDIT
	4 COINS	1 CREDIT
	5 COINS	1 CREDIT
	6 COINS	1 CREDIT
	7 COINS	1 CREDIT
	8 COINS	1 CREDIT
	9 COINS	1 CREDIT
BONUS ADDER	NO BONUS ADDER	
	2 COINS GIVE 1 EXTRA COIN	
	3 COINS GIVE 1 EXTRA COIN	
	4 COINS GIVE 1 EXTRA COIN	
	5 COINS GIVE 1 EXTRA COIN	
	6 COINS GIVE 1 EXTRA COIN	
	7 COINS GIVE 1 EXTRA COIN	
	8 COINS GIVE 1 EXTRA COIN	
	9 COINS GIVE 1 EXTRA COIN	
COIN CHUTE MULTIPLIER	1 COIN COUNTS AS 1 COIN	
	1 COIN COUNTS AS 2 COINS	
	1 COIN COUNTS AS 3 COINS	
	1 COIN COUNTS AS 4 COINS	
	1 COIN COUNTS AS 5 COINS	
	1 COIN COUNTS AS 6 COINS	
	1 COIN COUNTS AS 7 COINS	
	1 COIN COUNTS AS 8 COINS	
	1 COIN COUNTS AS 9 COINS	

## 7 - 12 REAL TIME CLOCK TEST

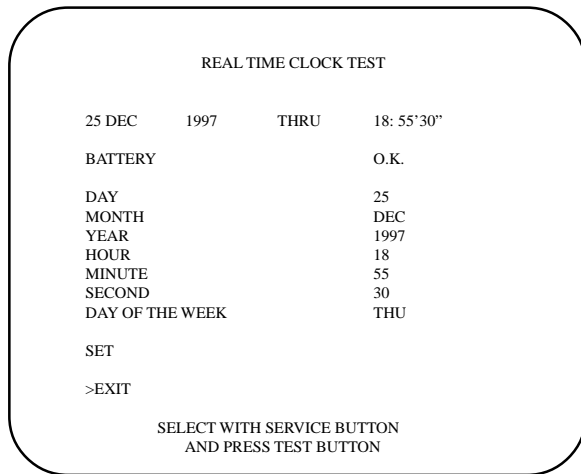

Fig. 7.12 REAL TIME CLOCK TEST

The system of this product has calendar functions. In the Game Assignments, if the Tournament mode is set to ON, ensure the present time is correct in this mode.

1. Press the Service button and bring arrow to the desired item to be changed.
2. Press the test button to change year, month, day, and hour.
3. Bring the arrow to SET and press test button.
4. Move the arrow to EXIT and press the TEST button to return to menu mode.

In the case an appropriate value is not displayed in the input test mode, the Volume can be adjusted in this mode. Set an appropriate Volume value by moving the HandleBar, Accelerator Grip, Front Brake, and Rear Brake fully within its movable range. The numeral values are hexadecimally displayed.

## 7 - 13 VOLUME ADJUSTMENTS

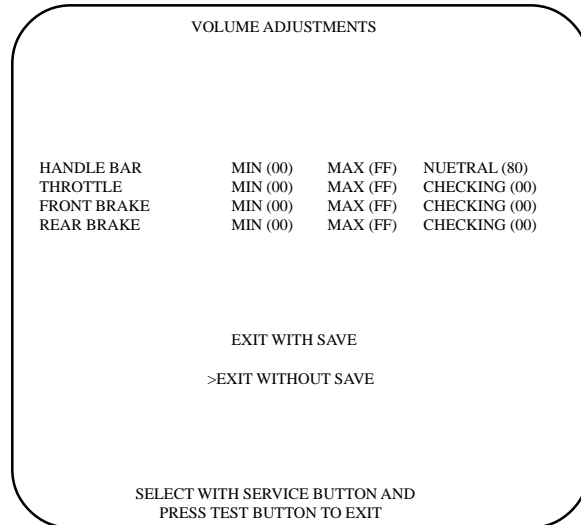

Fig. 7.13b VOLUME SETTING

- HANDLE BAR: After turning the handlebar fully to the left and right, return it to the center and ensure the status in which force is not exerted.
- THROTTLE: After fully moving accelerator grip, let go your hold and return to the status in which force is not exerted.
- FRONT BRAKE: Fully grip the front brake and let go your hold, then return to the status in which force is not exerted.
- REAR BRAKE: Fully step on the rear brake pedal and then release to return to the status of which force is not exerted.

Bring the cursor to EXIT WITH SAVE and press the test button to have the contents of the new input setting registered and return to the menu mode.

Bring the cursor to EXIT WITHOUT SAVE to return to the menu mode without changing the current settings.

## 7 - 14 NETWORK ASSIGNMENTS

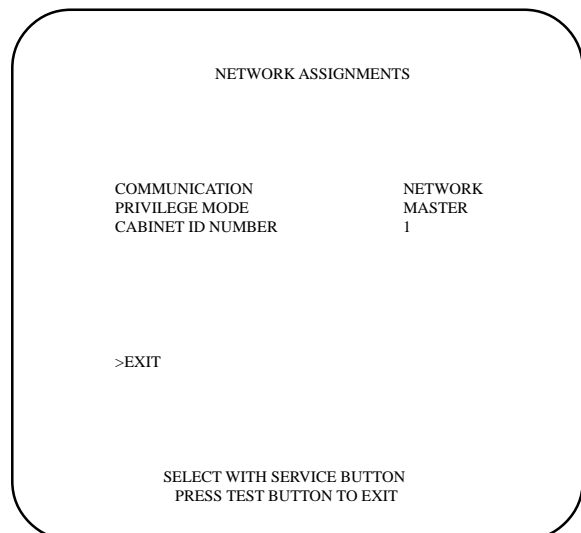

FIG. 7.14 NETWORK ASSIGNMENTS

THIS TEST MENU ALLOWS FOR THE ADJUSTMENT OF THE NETWORK SETUP.

- COMMUNICATION: Select NETWORK or STAND ALONE. When NETWORK is selected, the following are displayed.
- PRIVILEGED MODE: In the case plural machines are used for interactive play, set one of them to MASTER and set the rest of them to SLAVE. The Game Assignments set to the MASTER cabinet will also be applied to the SLAVE cabinets. Changing the settings by the SLAVE units is ineffective.
- CABINET ID NUMBER: In the case of plural machines are linked for interactive play, set the CABINET ID NUMBER in the order of 1, 2, 3, and 4 starting from the left most cabinet as seen from the front of the cabinet. If an identical number is set to 2 or more cabinets or if settings is made in the wrong order, the display during the game will be incorrect. Be careful of this point.



## 7 - 15 BOOKKEEPING

Choosing BOOKKEEPING in the MENU mode displays the data of operating status up to the present are shown on 2 pages. Press the TEST BUTTON to proceed to PAGE 2/2.

BOOKKEEPING		PAGE 1/2
COIN REPORT		
COIN CHUTE #1		XXXXXXXXXX
COIN CHUTE #2		XXXXXXXXXX
TOTAL COINS		XXXXXXXXXX
COIN CREDITS		XXXXXXXXXX
SERVICE CREDITS		XXXXXXXXXX
TOTAL CREDITS		XXXXXXXXXX
NUMBER OF GAMES		
1 P GAMES		XXXXXXXXXX
2 P GAMES		XXXXXXXXXX
NUMBER OF CONTINUE		
1 P GAMES		XXXXXXXXXX
2 P GAMES		XXXXXXXXXX
TOTAL	TIME	XDXXHXXMXXS
PLAY	TIME	XDXXHXXMXXS
AVERAGE PLAY	TIME	XXMXXS
LONGEST PLAY	TIME	XXMXXS
SHORTEST PLAY	TIME	XXMXXS

PRESS TEST BUTTON TO CONTINUE

FIG. 7.15a BOOKKEEPING (1/2)

BOOKKEEPING		PAGE 2/2
TIME HISTOGRAM		
0M00S ~ 0M29S		XXXXXXXXXX
0M30S ~ 0M39S		XXXXXXXXXX
0M40S ~ 0M49S		XXXXXXXXXX
0M50S ~ 0M59S		XXXXXXXXXX
1M00S ~ 1M09S		XXXXXXXXXX
1M10S ~ 1M19S		XXXXXXXXXX
1M20S ~ 1M29S		XXXXXXXXXX
1M30S ~ 1M39S		XXXXXXXXXX
1M40S ~ 1M49S		XXXXXXXXXX
1M50S ~ 1M59S		XXXXXXXXXX
4M00S ~ 4M09S		XXXXXXXXXX
4M10S ~ 4M19S		XXXXXXXXXX
4M20S ~ 4M29S		XXXXXXXXXX
4M30S ~ 4M39S		XXXXXXXXXX
4M40S ~ 4M49S		XXXXXXXXXX
4M50S ~ 4M59S		XXXXXXXXXX
5M00S ~		XXXXXXXXXX

PRESS TEST BUTTON TO EXIT

FIG. 7.15b BOOKKEEPING (2/2)

- **COIN CHUTE#\*:**  
Number of coins put in each Coin Chute.
- **TOTAL COINS:**  
Total number of activations of Coin Chutes.
- **COIN CREDITS:**  
Number of credits registered by inserting coins.
- **SERVICE CREDITS:**  
Credits registered by the SERVICE BUTTON.
- **TOTAL CREDITS:**  
Total number of credits (COIN CREDITS+SERVICE CREDITS).
- **TOTAL TIME:**  
The total energized time.

On page (2/2), each play frequency is displayed. When setting difficulty levels, the frequency can be referred to as a standard.

When in the PAGE 2/2 mode, press the TEST BUTTON to return to the MENU mode.

## 7 - 16 BACKUP DATA CLEAR

BACKUP DATA CLEAR	
	YES (CLEAR)
>NO (CANCEL)	
SELECT WITH SERVICE BUTTON	
PRESS TEST BUTTON TO EXIT	

FIG. 7.16 BACKUP DATA CLEAR

- Clears the contents of BOOKKEEPING and high score player ranking entry.
- When clearing, bring the arrow to “YES” and when not clearing, to “NO”, by using the SERVICE BUTTON, and push the TEST BUTTON.
- When the data has been cleared, “COMPLETED” will be displayed. Bring the arrow to “NO” and press the TEST BUTTON to cause the MENU mode to return on to the screen.
- Note that the contents of the GAME SETTING, COIN SETTING, and BOARD SETTING are not affected by BACKUP DATA CLEAR operation.

## 8 . HANDLEBAR



- In order to prevent an electric shock and short circuit, be sure to turn power off before performing work by touching the interior parts of the product.
- Be careful so as not to damage wirings. Damaged wiring can cause an electric shock or short circuit accident.

### 8 - 1 ADJUSTING/REPLACING THE FRONT BRAKE VOLUME

In the test mode, if the Front Brake Volume's Value movements are irregular, adjust or replace the Volume by using the following procedure:

Take out the 4 screws and remove the VR cover.

The Front Brake Volume is inside the VR cover.

#### VOLUME ADJUSTMENT

- ① Loosen the 2 screws which secure the VR bracket to move the VR Bracket.
- ② Move the VR Bracket to disengage the gear mesh.
- ③ By adjusting gear mesh, fasten the 2 screws which secure VR Bracket.
- ④ Move the Brake Lever fully to the movable range and check if the Volume Shaft's revolvable range is exceeded.
- ⑤ After adjustment, be sure to perform the Volume setting in the Test Mode.

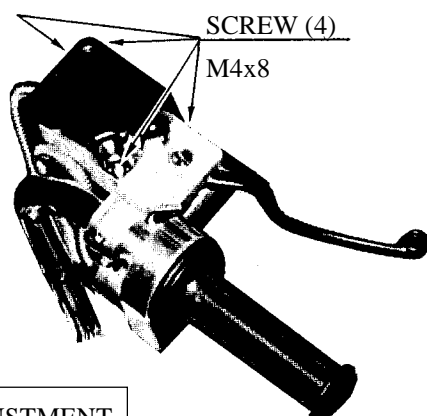

#### VOLUME ADJUSTMENT

Replace the Volume if it is malfunctioning.

Install the Volume in the manner so that 20+/-5 is indicated when force is not exerted.

- ① Remove the 2 screws which secure the VR Bracket.
- ② Remove the Volume Gear from the Volume Shaft and remove the Volume from the VR Bracket to replace the volume.
- ③ After the replacement, be sure to perform the Volume setting in the Test Mode.

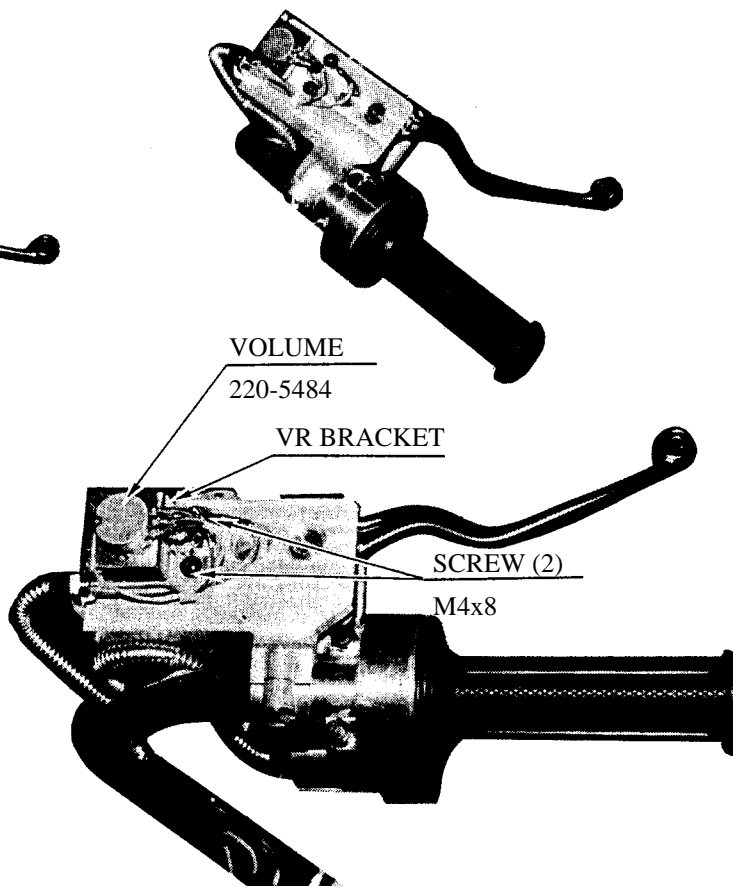

## 8 - 2 ADJUSTING/REPLACING THE ACCELERATOR VOLUME

In the test mode, if the Front Brake Volume's Value movements are irregular, adjust or replace the Volume by using the following procedure:

Take out the 4 screws and remove the VR cover.

The Front Brake Volume is inside the VR cover.

### VOLUME ADJUSTMENT

- ① Loosen the 2 screws which secure the VR bracket to move the VR Bracket.
- ② Move the VR Bracket to disengage the gear mesh.
- ③ By adjusting gear mesh, fasten the 2 screws which secure VR Bracket.
- ④ Move the Brake Lever fully to the movable range and check if the Volume Shaft's revolvable range is exceeded.
- ⑤ After adjustment, be sure to perform the Volume setting in the Test Mode.

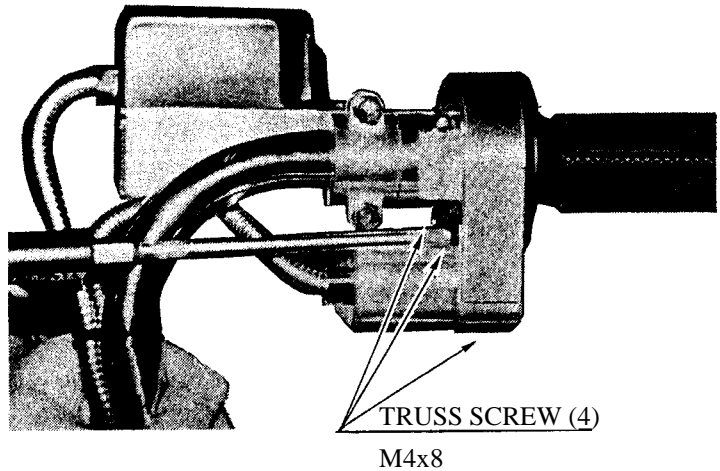

### VOLUME ADJUSTMENT

Replace the Volume if it is malfunctioning.  
Install the Volume in the manner so that 20+/-5 is indicated when force is not exerted.

- ① Remove the 2 screws which secure the VR Bracket.
- ② Remove the Volume Gear from the Volume Shaft and remove the Volume from the VR Bracket to replace the volume.
- ③ After the replacement, be sure to perform the Volume setting in the Test Mode.

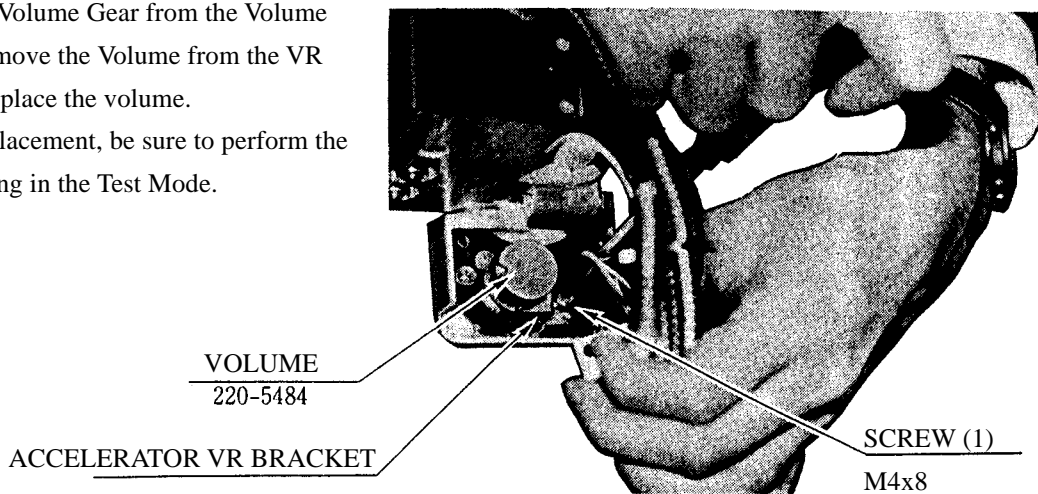
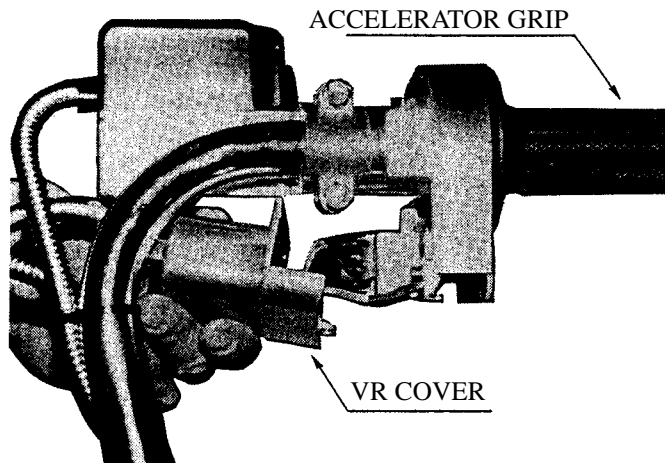

### 8 - 3 ADJUSTING/REPLACING THE HANDLEBAR VOLUME

In the Test Mode, if the HandleBar Volume's value movements are irregular, adjust or replace the Volume.

- ① Remove the 4 screws.

TRUSS SCREW (4)  
M4x8 (black)

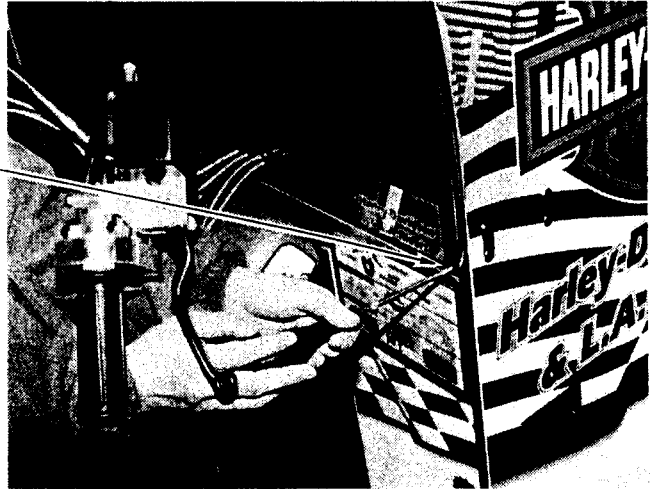

CONNECTORS

- ② Disconnect the 3 connectors and remove the mask cover.  
When the mask cover is removed, monitor screen adjustment knob appears.

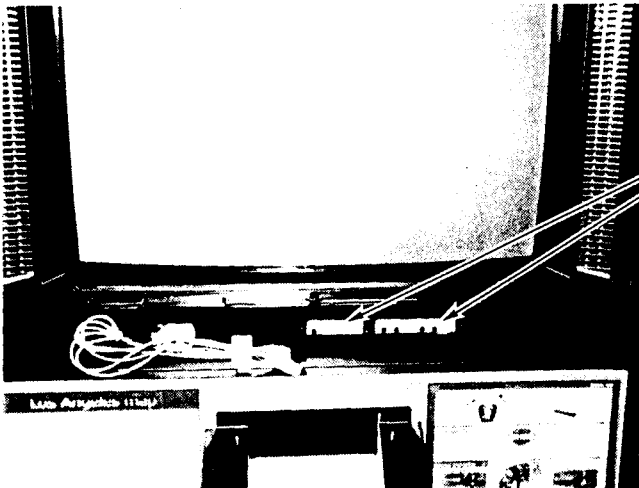
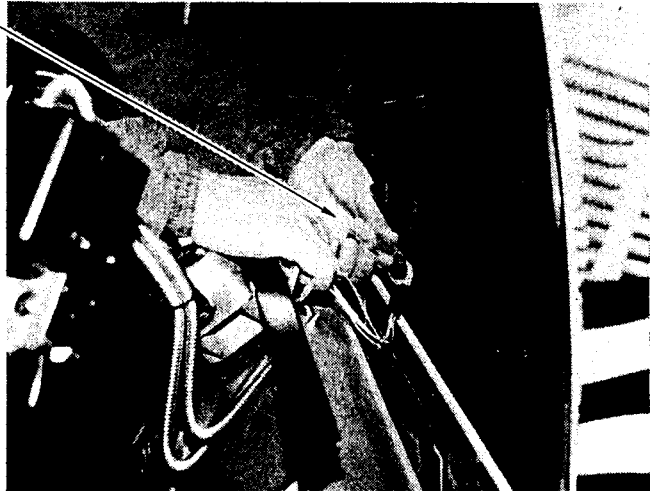

ADJUSTMENT KNOB

- ③ Remove the bolt w/hexagon hole and pull out the handle from the shaft.

Bolt w/hexagon hole  
M10x20,  
w/flat and spring washers

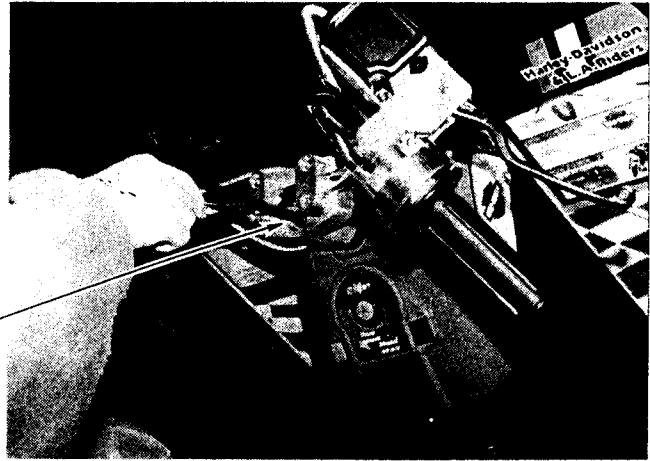

- ④ Take out the 3 screws, disconnect the connector inside the tank, and remove the tank.

TRUSS SCREW (3)  
M4x12, Flat washer

CONNECTOR  
8P YELLOW

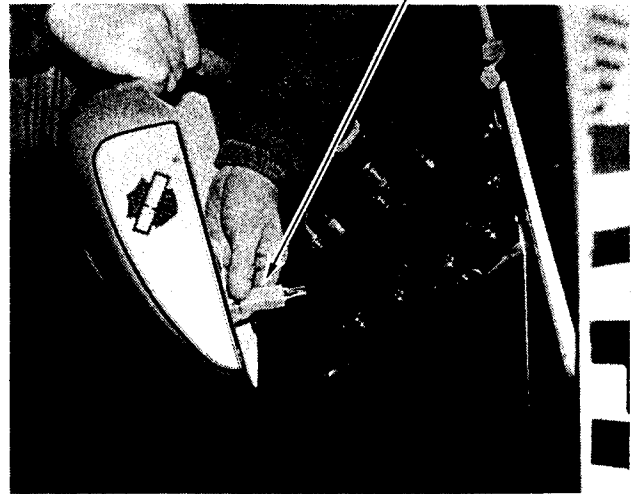
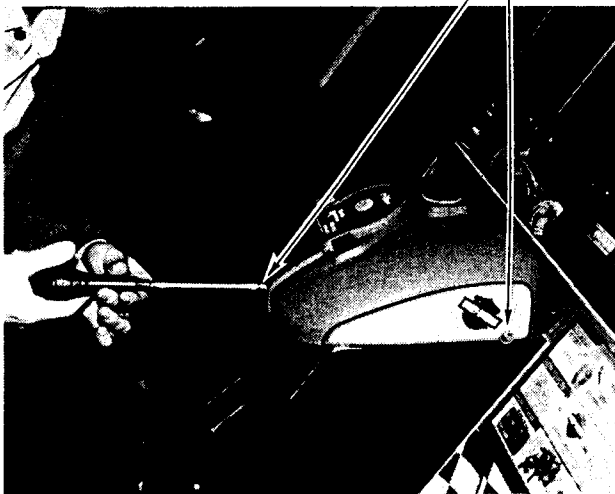

SCREW (1)  
M4x8,  
w/ flat and spring washers

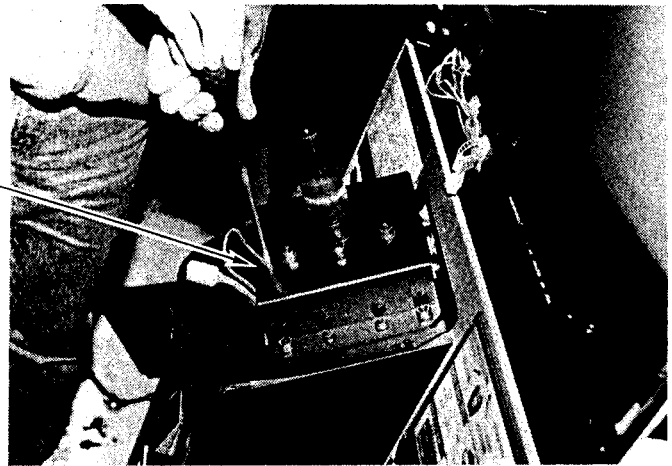

- ⑤ Remove the 4 hexagon nuts which secure the centering mecha. By viewing the centering mecha from above, remove the hexagon nuts from the four corners only.

HEXAGON NUT (4)  
M8  
w/ flat and spring washers

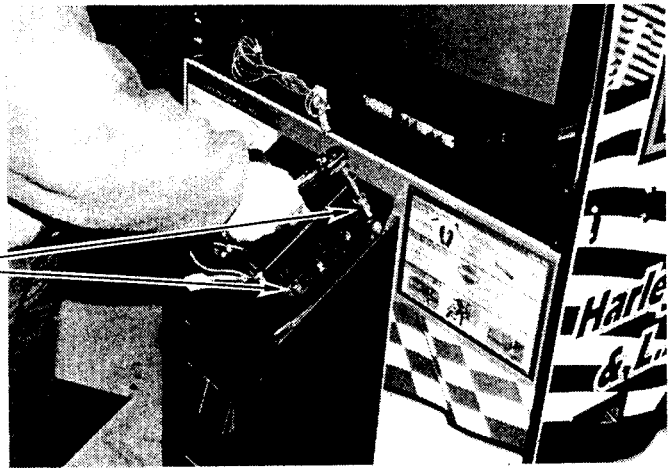

- ⑥ Carefully lift the centering mecha and disconnect the connector connected to the centering mecha.

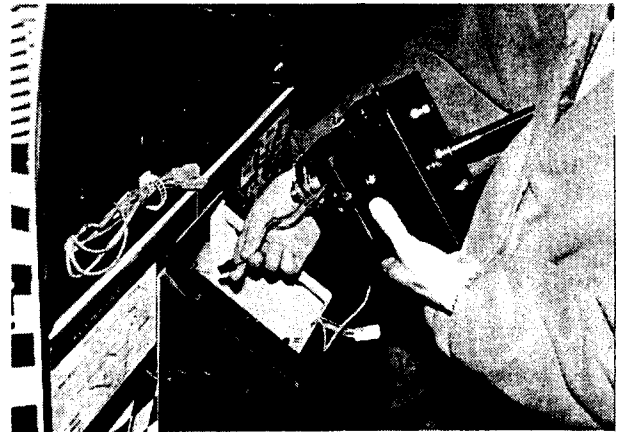
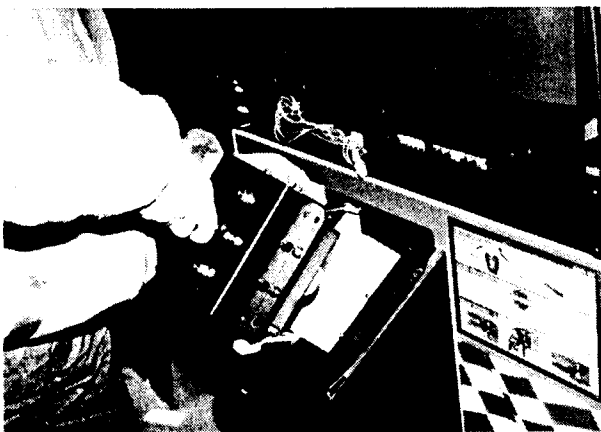

## V.R. ADJUSTMENT



IMPORTANT!

Do not touch places other than those specified. Touching places not specified can cause an electric shock and /or short circuit accident.

- ① Loosen the 2 screws which secure the V.R. Bracket to move the V.R. Bracket.
- ② Move the V.R. Bracket to disengage ADJUST GEAR mesh and move the V.R. shaft in the manner so that the V.R. shaft cut portion faces the opposite side of ADJUST GEAR as shown.
- ③ Have the gears meshed and tighten the 2 screws.
- ④ Carefully turn the Handle Shaft to left/right and check to ensure the value variation is within the mobile range of the Volume.
- ⑤ After finishing adjustments, be sure to perform Volume Setting in Test Mode.

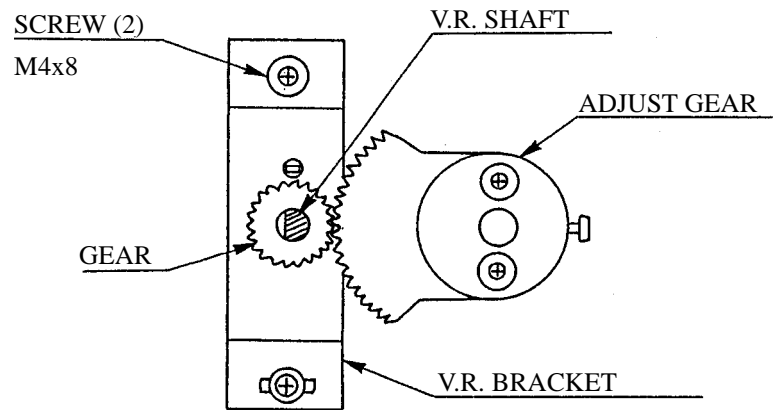

## V.R. REPLACEMENT

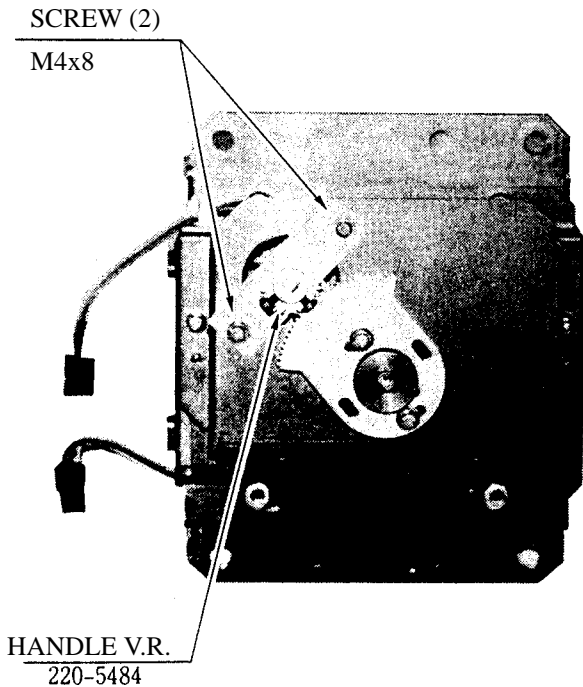

- ① Take out the 2 screws which secure the Volume Bracket to remove the Volume Bracket.
- ② Remove the Volume Gear from the V.R. to replace the V.R.
- ③ After the replacement, perform Volume Setting in the Test Mode.

8 - 4 GREASING



IMPORTANT!

Be sure to use the designated grease. Using undesignated grease can cause parts damage.

Do not apply greasing to places other than those specified. Greasing to undesignated places can cause malfunctioning and the qualitative deterioration of parts.

Once every three months, apply greasing to the following places.

For Greasing use Grease Mate (P.No. 090-0066).

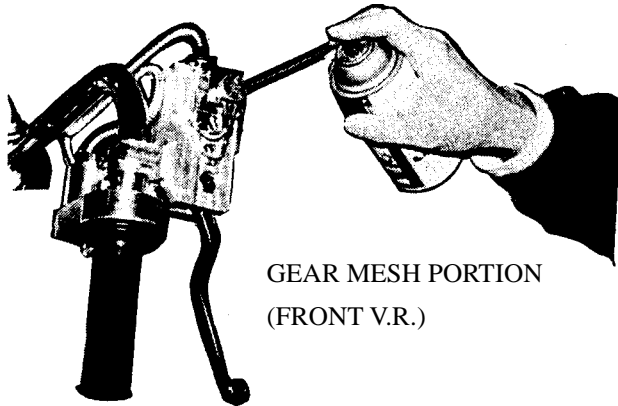

GEAR MESH PORTION  
(FRONT V.R.)

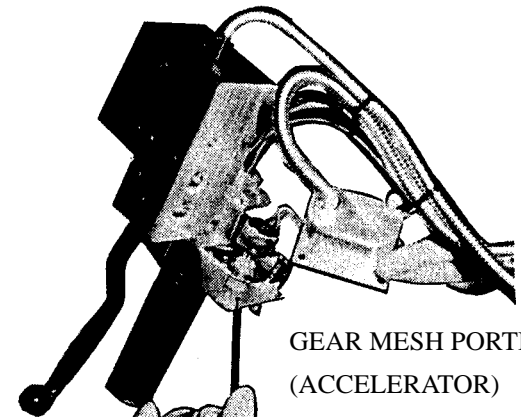

GEAR MESH PORTION  
(ACCELERATOR)

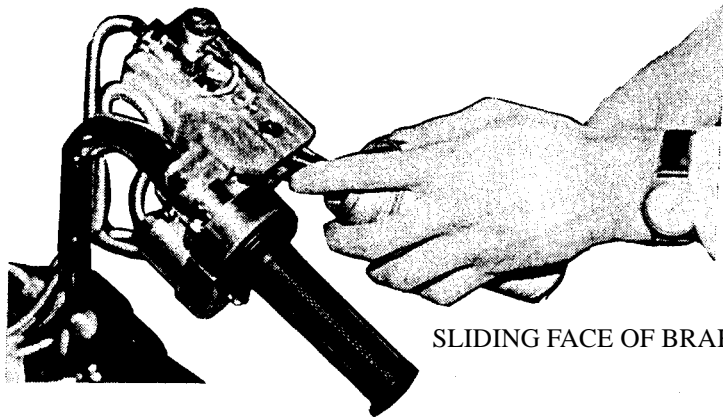

SLIDING FACE OF BRAKE

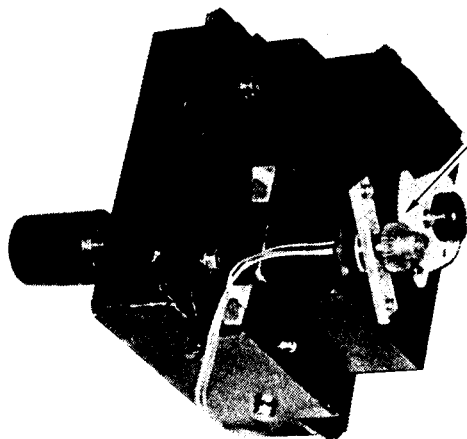

GEAR MESH PORTION  
(FRONT V.R.)



## 9. FOOT BRAKE MECHA



WARNING!

In order to prevent an electric shock and short circuit, be sure to turn power off before performing work by touching the interior parts of the product.

Be careful so as not to damage wirings. Damaged wiring can cause an electric shock or short circuit accident.

Do not touch places other than those specified. Touching places not specified can cause an electric shock or short circuit accident.

### 9 - 1 ADJUSTING AND REPLACING THE VOLUME

In the Test Mode, if the Rear Brake's (Foot Brake's) volume movements are irregular, adjust or replace the Volume by using the following procedure.

- ① Remove the 6 screws.
- ② Disconnect the connector, and remove the Foot Brake Mecha from the cabinet.

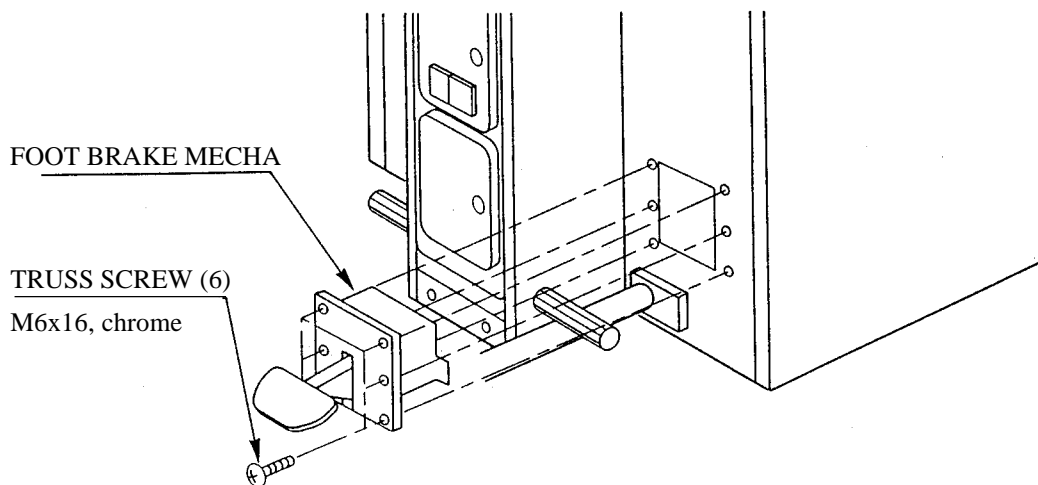
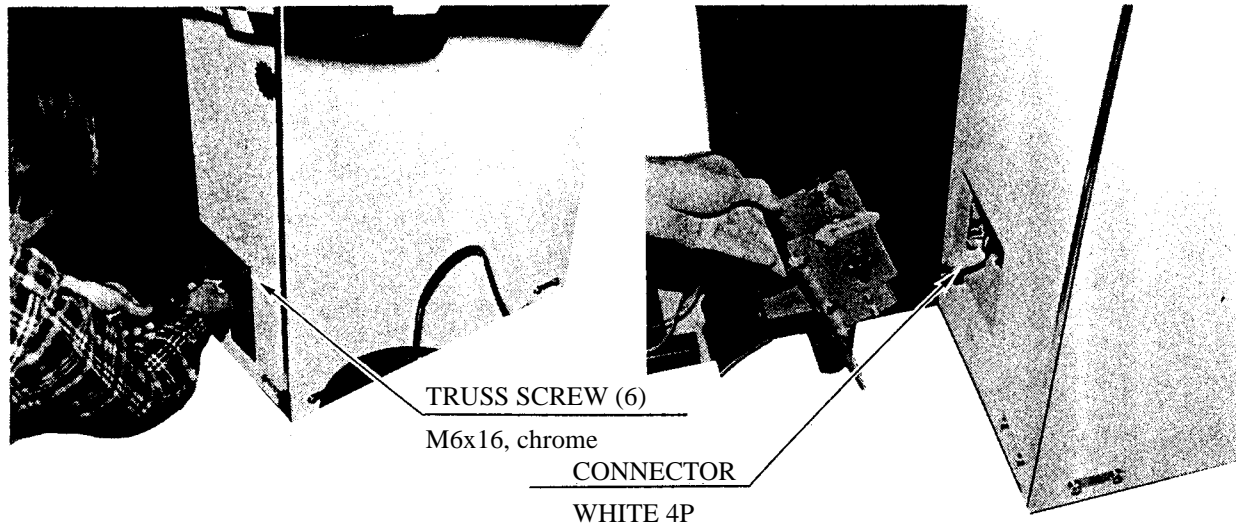

### V.R. ADJUSTMENT

- ① Loosen the 2 screws which secure the V.R. Plate to move the V.R. Plate.
- ② Move the V.R. Plate to disengage ADJUST GEAR mesh and move the V.R. shaft and ensure that when force is not exerted on the pedal, the cut face of the Volume Shaft faces in the direction shown.
- ③ Have the gears meshed and tighten the 2 screws. At this time, tighten gear backlash.
- ④ Carefully move pedal fully within the movable range and check if the Volume range is exceeded.
- ⑤ After finishing adjustments, be sure to perform Volume Setting in Test Mode.

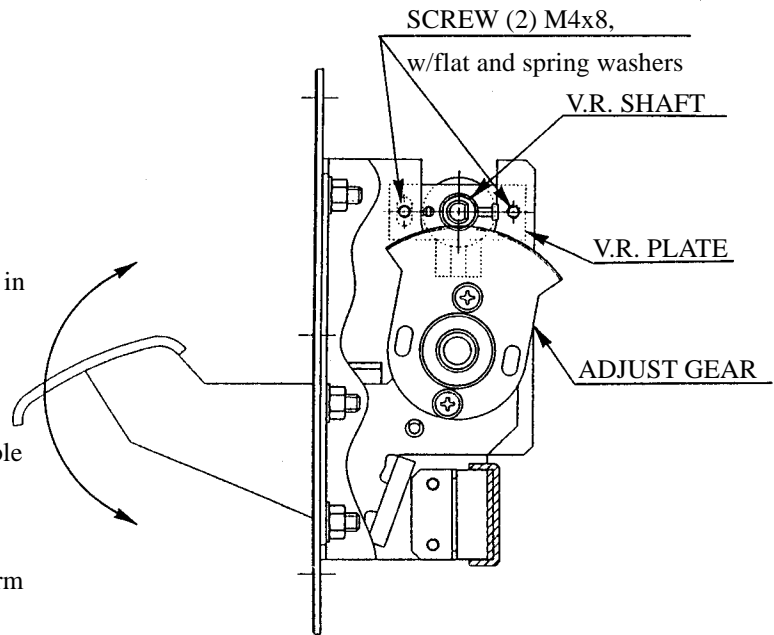

### V.R. REPLACEMENT

- ① Take out the 2 screws which secure the Volume Plate to remove the Volume Plate.
- ② Remove the Volume Gear from the V.R. to replace the V.R.
- ③ After the replacement, perform Volume Setting in the Test Mode.

9 - 2 GREASING



IMPORTANT!

Be sure to use the designated grease. Using undesignated grease can cause parts damage.

Do not apply greasing to places other than those specified. Greasing to undesignated places can cause malfunctioning and the qualitative deterioration of parts.

Once every three months, apply greasing to the following places.

For Greasing use Grease Mate (P.No. 090-0066).

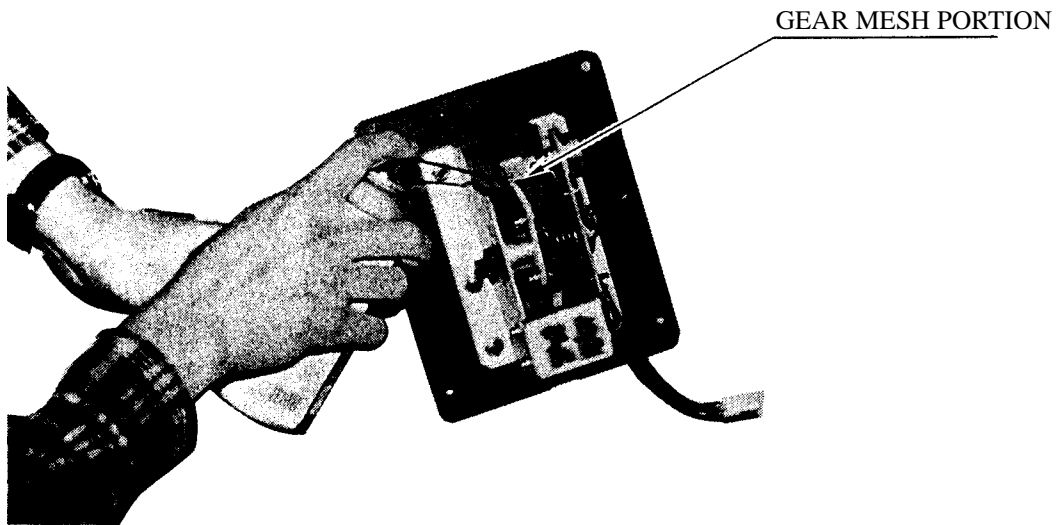

SLIDING FACE OF SPRING AND SHAFT

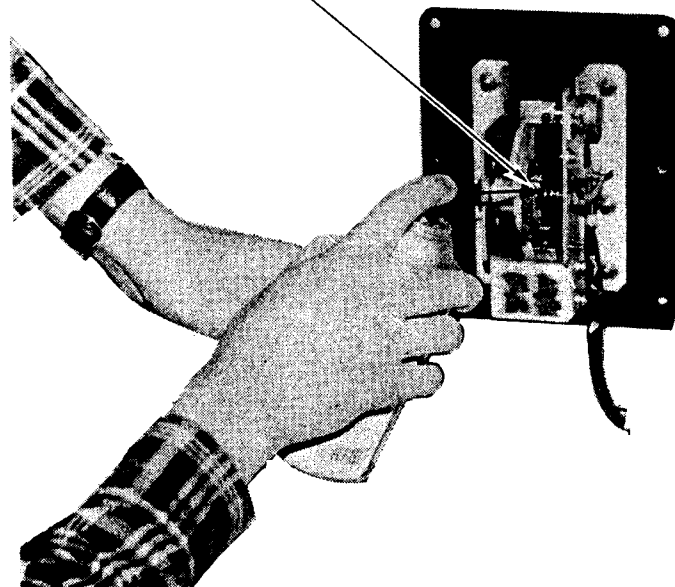

## 10 . COIN SELECTOR

### HANDLING THE COIN JAM

If the coin is not rejected when the REJECT BUTTON is pressed, open the coin chute door and open the selector gate. After removing the jammed coin, put a normal coin in and check to see that the selector correctly functions.

### CLEANING THE COIN SELECTOR

The coin selector should be cleaned once every 3 months. When cleaning, follow the procedure below:

- ① Turn the power for the machine OFF. Open the coin chute door.
- ② Open the gate and dust off by using a soft brush (made of wool, etc.).
- ③ Remove and clean smears by using a soft cloth dipped in water or diluted chemical detergent and then squeezed dry.
- ④ Remove the CRADLE. When removing the retaining ring(E-ring), be very careful so as not to bend the shaft.
- ⑤ Remove stain from the shaft and pillow portions by wiping off with a soft cloth, etc.
- ⑥ After wiping as per #5 above, further apply a dry cloth, etc. to cause the coin selector to dry completely.

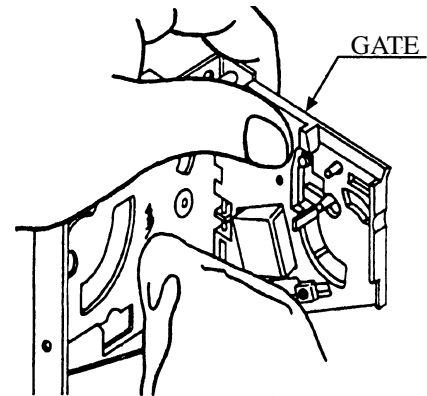

FIG. 9a

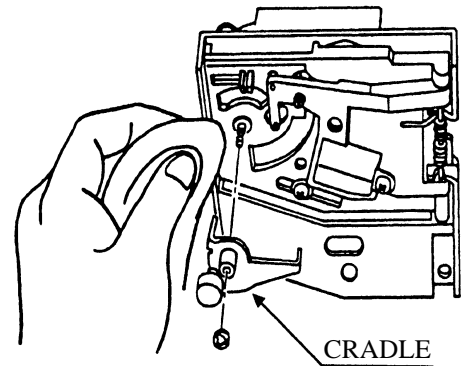

FIG.9b



IMPORTANT!

- Never apply machine oil, etc. to the coin selector
- After cleaning the Coin Selecting, Insert a regular coin in the normal working status and ensure that the Selector correctly functions.

### COIN INSERTION TEST

Once a month, when performing the COIN SW TEST, simultaneously check the following:

- Does the Coin Meter count satisfactorily?
- Does the coin drop into the Cashbox correctly?
- Is the coin rejected when inserted while keeping the REJECT BUTTON is pressed down?

Insert a coin while keeping the Reject Button pressed down and check if it is rejected.

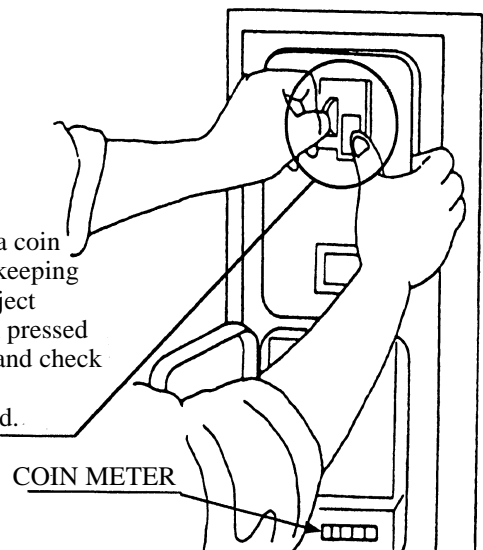

FIG. 9c

OPTIONAL DOLLAR BILL ACCEPTOR

● THE COIN DOOR ASSEMBLY USED ON **HARLEY DAVIDSON U/R** COMES EQUIPPED TO ACCEPT A DOLLAR BILL ACCEPTOR. ALL NEEDED WIRING CONNECTIONS ARE CONVIENENTLY LOCATED INSIDE THE GAME FOR THIS APPLICATION.

● THE COIN DOOR CAN ACCCOMMODATE THE FOLLOWING VALIDATORS:

HOLE POSITION#1 (FORWARD-MOST POSITION)	Mars 2000 series
HOLE POSITION#2	Mars 2000 series DBV45 (JCM)
HOLE POSITION #3	CURRENTLY NOT USED
HOLE POSITION #4	DSI01*

\*The back flange on the chute can be removed for hold position #4. If the flange is not removed, it may interfere with the back of the cabinent.

The frame and cashbox enclosure on this coindoor has been modified to accomodate a Mars 2000 series upstacker. A 2000 series stacker can be added by simply removing the top two entry door and replacing it with a one entry door with a cut-out for a stacker. This one entry door can be ordered through Coin Controls or one of Coin Controls authorized distributors. The part number is 91-4000-01. The Mars stacker can be obtained through an authorized Mars distibutor.

# COIN CONTROLS INTERNATIONAL

1850 HOWARD ST., ELK GROVE IL 60007  
(847) 228-1810

## OVER/UNDER TWO ENTRY COIN DOOR\*

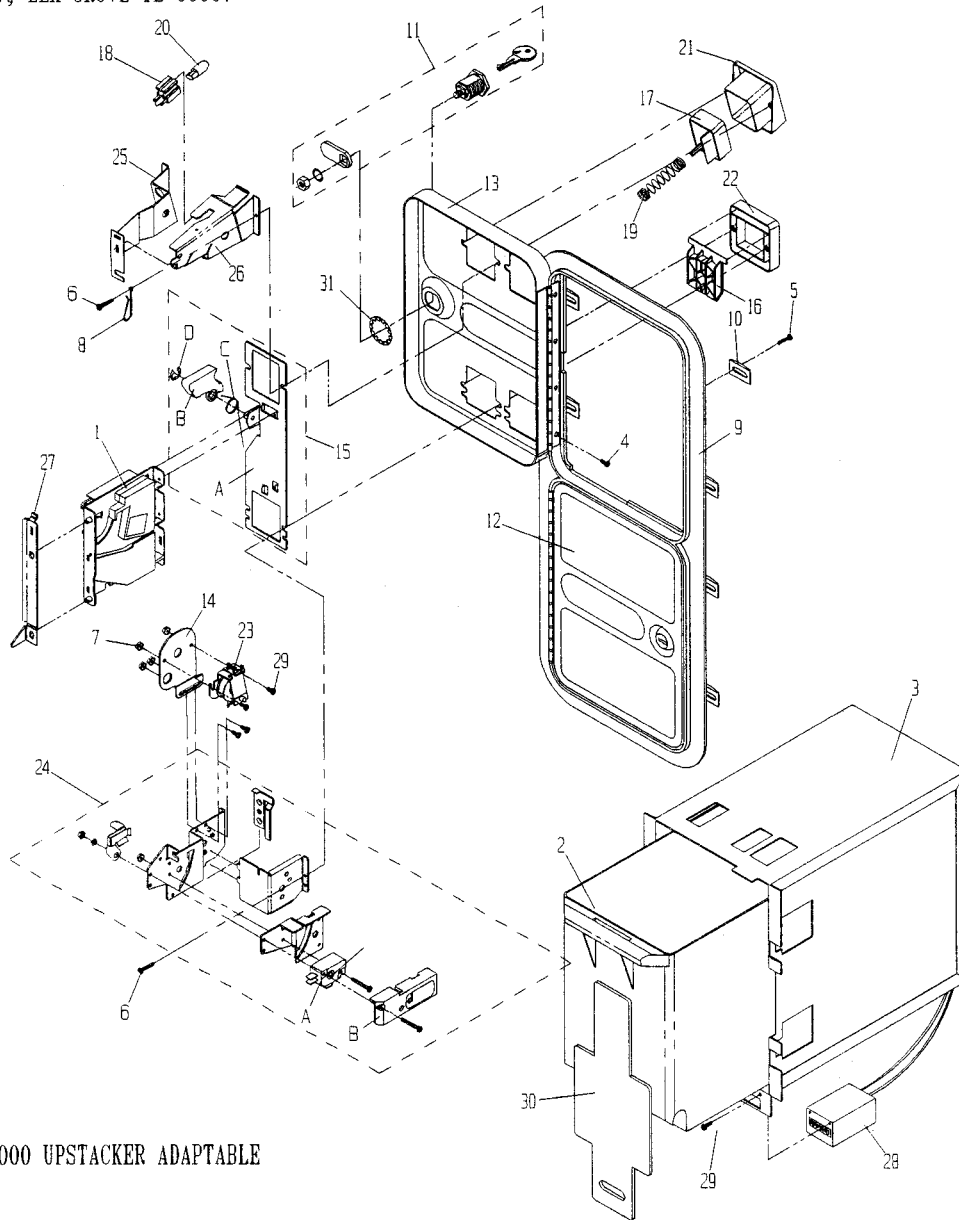

\* MARS SERIES 2000 UPSTACKER ADAPTABLE

PART #	DESCRIPTION	COST	PART #	DESCRIPTION	COST	PART #	DESCRIPTION	COST
1)	12-4050-XX S-10 ACCEPTOR	19.50	16)	91-1109-16 REJECT FLAP NYLON, BLACK	2.70	28)	23-1011-00 12V DC METER	8.50
	12-4150-011 S-7 US #.25	12.00	17)	91-1113-01 ENTRY/REJECT BUTTON 25c	4.45		23-1103-00 4.5V DC METER	8.50
2)	20-4177-00 PLASTIC CASEBOX	7.40	18)	91-1117-00 LAMPHOLDER	1.40	29)	90-1032-01 METER & LOCKOUT SCREW	.25
3)	20-4189-00 ENCLOSURE, Z2000	27.50	19)	91-1121-00 E/R BUTTON SPRING	.80	30)	22-1400-00 LOCKING BAR	7.00
4)	90-1002-00 HINGE SCREW	.25	20)	91-1118-00 6V LAMP WEDGE BASE	.95	31)	90-1019-00 3/4" LOCKWASHER	.25
5)	90-1003-00 CLAMP SCREW	.95	21)	91-1311-16 BUTTON BEZEL BLACK	2.70			
6)	90-1017-00 SCREW BEZEL NYLON	.25	22)	91-1312-16 REJECT BEZEL BLACK	2.70			
7)	90-1206-02 #4-40 KEP NUT	.25	23)	91-2125-00 12V LOCKOUT COIL ASSEMBLY	12.85			
8)	90-1300-00 KEYHOOK	.35	24)	91-2216-16 MICROSWITCH ASSEMBLY	15.00			
9)	91-0508-16 FRAME	30.00	24A)	91-1116-16 MICROSWITCH BLACK	5.40			
10)	91-0506-00 CLAMP	.45		91-1116-11 MICROSWITCH WHITE	5.40			
11)	91-0547-00 DOUBLE D CAM LOCK	5.25		91-1116-10 MICROSWITCH RED	5.40			
12)	91-0603-16 BLACK MINI DOOR	8.40	24B)	91-1125-00 MICROSWITCH PLASTIC COVER	.85			
13)	91-0604-16 2 ENTRY UPPER DOOR	10.00	25)	92-1002-01 COIN INLET LAMP SIDE	1.80			
14)	91-1008-039 LOCKOUT BRACKET	4.30	26)	92-1002-021 COIN INLET COVER SIDE	1.80			
15)	91-1008-107 BASEPLATE ASSEMBLY	5.00	27)	92-1002-10 HOLD DOWN BRACKET	1.50			

# 11 . MONITOR



CAUTION!

When performing such work as installing and removing the monitor, inserting and disconnecting the external connectors to and from monitor, be sure to disconnect the power connector (plug) before starting work. Proceeding the work without following this instruction can cause electric shock or malfunctioning.

Using the monitor by converting it without obtaining a prior permission is not allowed. SEGA shall not be liable for any malfunctioning and accident caused by said conversion.



WARNING!

## Primary side and secondary side

The monitor's circuit which is divided into the Primary side and secondary side, is electrically isolated. Do not touch the primary side and the secondary side simultaneously. Failing to observe the instruction can cause electric shock, and this is very dangerous. When making monitor adjustments, use a non-conductive driver and make adjustment without touching any other part other than the Adjustment V.R. and Knob. Also, be sure not to cause a short-circuit to the Primary side and the Secondary side. If short-circuited, it can cause electric shock or malfunctioning, which is very dangerous.

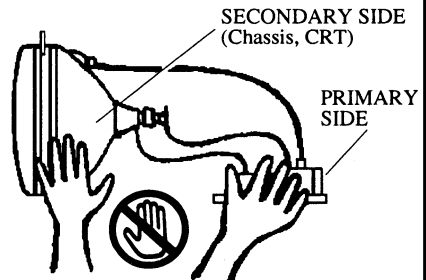

## High tension Voltage

Some of the parts inside the monitor are subject to high-tension voltage in excess of 20,000 volts and very dangerous. Therefore, do not touch the monitor interior. Should soldering & paper wastes, etc. be mixed in the monitor, turn the power off so as not to cause malfunctioning or fire hazard.

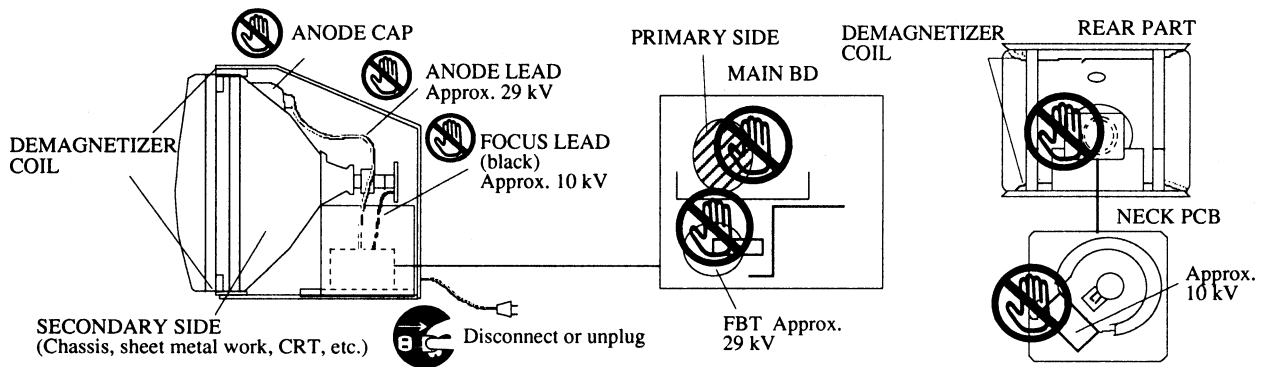

## Connecting the CRT and PCB

For combining the CRT and PCB, use the specified part No. to maintain the status of adjustments made at the factory. The anode of the CRT itself will be accumulatively charged as time elapses, generating high tension voltage which is very dangerous. The monitor should be used with the Chassis, CRT and PCB assembled. When repair, etc. is required at the time of malfunctioning, be sure to send it in an "as assembled" condition. If these are disassembled, what's charged to said high tension voltage can be discharged, causing a very hazardous situation. Therefore, under no circumstances should it be disassembled.



CAUTION!

## Static Electricity

Touching the CRT surface sometimes causes you to slightly feel electricity. This is because the CRT surfaces are subject to static and will not adversely affect the human body.

## Installation and removal

Ensure that the Magnetizer Coil, FBT (Fly-Back Transformer), Anode Lead and Focus Lead are not positioned close to the sheet metal work's sharp edges, etc. and avoid damaging the insulated portions so as not to cause an electric shock and malfunctioning. (For the name of parts, refer to the above figures.)



For the purpose of static prevention, special coating is applied to the CRT face of this product. To protect the coating, pay attention to the following points. Damaging the coating film can cause electric shock to the customers. For the caution to be heeded when clearing, refer to the Section of Periodic inspection Table.

Do not apply or rub with a hard item (a rod with pointed edge, pen, etc.) to or on C.R.T. surfaces.

Avoid applying stickers, seals, etc. on the C.R.T. face.

Do not remove aluminum foils from the C.R.T. corners. Removing the aluminum foils can cause static prevention effects to be lowered.

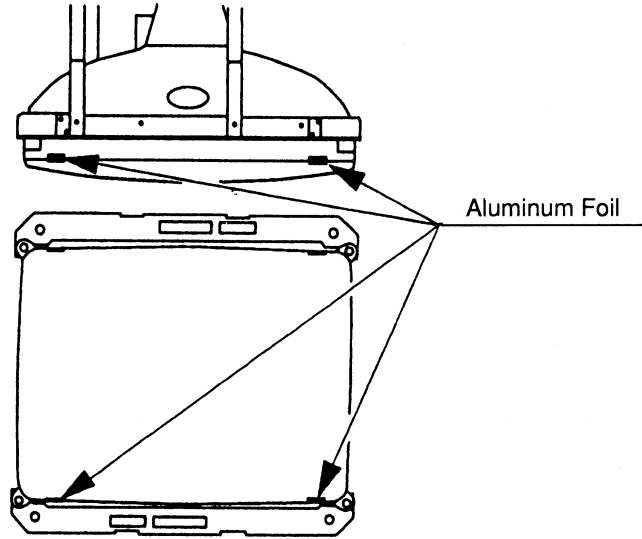



NANAO monitor: 2 0 0 - 5 2 4 2 - 2 4 - 0 4 (24K mode)

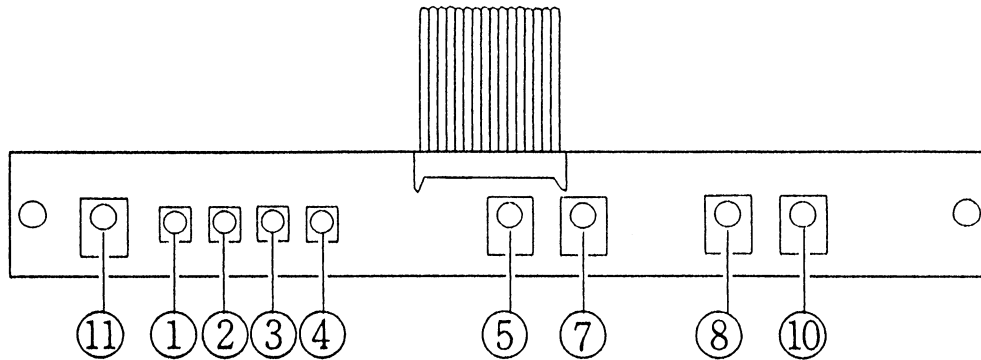

SANWA monitor: 2 0 0 - 5 2 4 3 - 2 4 (24K mode)

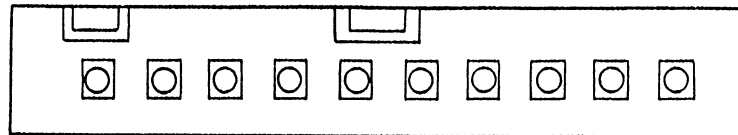

①	②	③	④	⑤	⑥	⑦	⑧	⑨	⑩
R GAIN	G GAIN	B GAIN	BRIGHT	H SIZE	H HOLD	H POSI	V SIZE	V HOLD	V POSI

- ① R-GAIN
- ② G-GAIN ..... Controls colors.
- ③ B-GAIN
- ④ BRIGHT ..... Controls screen brightness.
- ⑤ H. SIZE ..... Controls horizontal screen size.
- ⑥ H. HOLD ..... Provides horizontal synchronization, i.e., controls right/left hold.
- ⑦ H. POSI ..... Controls horizontal display position on screen.
- ⑧ V. SIZE ..... Controls vertical screen size.
- ⑨ V. HOLD ..... Provides vertical synchronization, i.e., controls up-down hold.
- ⑩ V. POSI ..... Controls vertical display position on screen.
- ⑪ CONTRAST .... Adjusts image contrast.

## 12 . REPLACEMENT OF FLUORESCENT LAMP AND LAMPS



- When performing the work, be sure to turn power off. Working with power on can cause an electric shock or short circuit accident.
- The Fluorescent Lamp, when it gets hot, can cause burns. Be very careful when replacing the Fluorescent Lamp.



To perform work safely and securely, be sure to prepare a step which is in a secure and stable condition. Not using a step or using an unstable step can cause a violent falling down accidents.

### 12 -1 REPLACEMENT OF FLUORESCENT LAMP

- ① Take off the 3 screws which secure the Holder on the upper part of Billboard.
- ② Take out the billboard from the cabinet and replace the fluorescent lamp (20W)

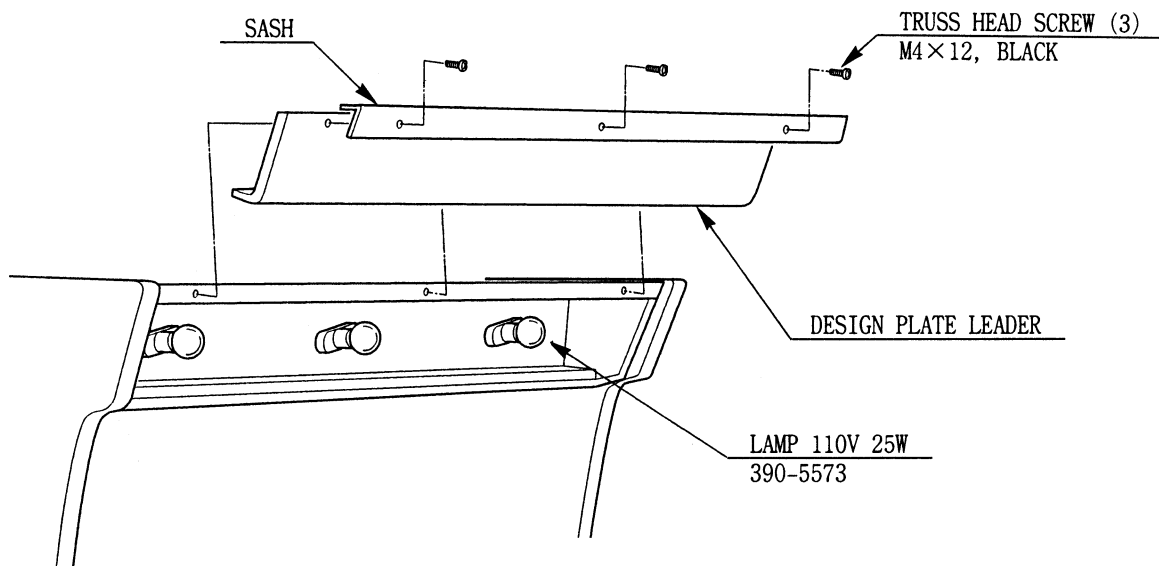

## 12 - 2 REPLACING THE LAMP

- ① Take out the screw to remove the lamp from the lamp body.

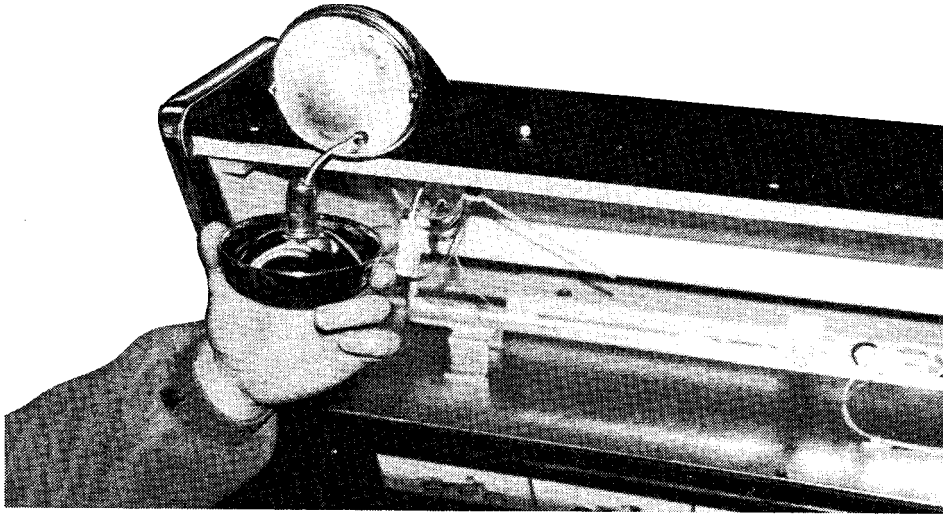

- ② By using a flat blade screwdriver, remove the 3 inside fasteners.

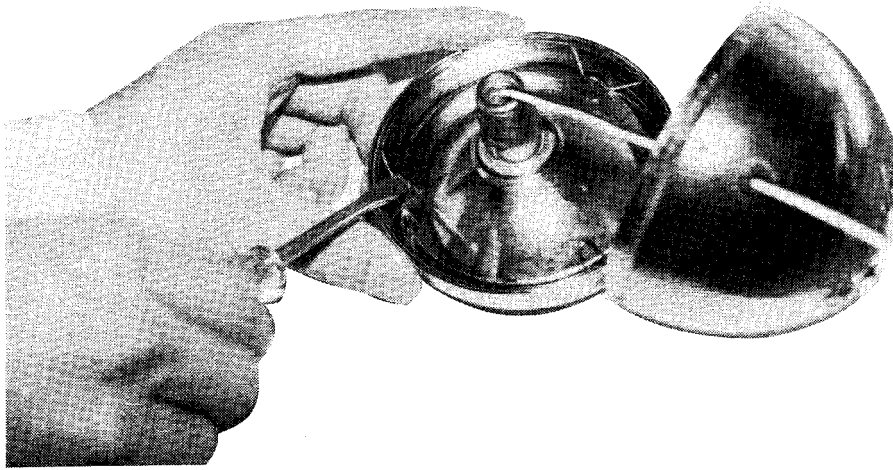

- ③ As shown left, disassemble the lamp parts and replace the lamp.

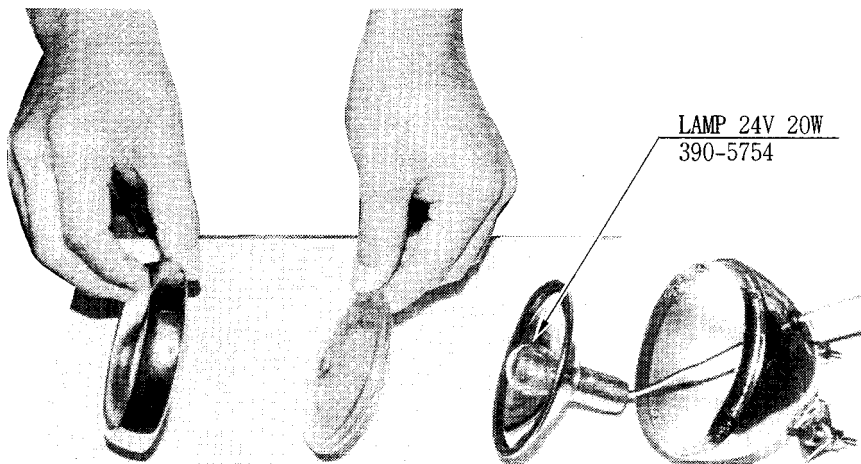

### 13 . PERIODIC INSPECTION TABLE

The items listed below require periodic check and maintenance to retain the performance of this machine and ensure safe operation.



- Be sure to check once a year to see if Power Cords are damaged, the plug is securley inserted, dust is accumulated between the Socket Outlet and the Power Plug, etc. Using the product with dust as is accumulated can cause a fire or electrical shock.
- Periodically once a year, request the place of contact herin stated or the Distributer, etc. where the product was purchased from, as regards the interior cleaning. Using the product with dust as is accumulated in the interior without cleaning can cause a fire or accident. Note that cleaning the interior parts can be performed on a pay-basis.

ITEMS	DESCRIPTION	PERIOD	REFERENCE
BIKE MECHA	Volume V.R. inspection	Monthly	7, 8
	Greasing to gears and springs	Monthly	8
	Memory Test	Monthly	7
	Setting Check	Monthly	7
BRAKE MECHA	SW Volume inspection	Monthly	7, 8
	Greasing to gears and springs	Tri-monthly	8
	Check Volume Value.	Monthly	7
COIN SELECTOR	Check COIN SW	Monthly	7
	COIN SELECTOR cleaning	Trimonthly	10
PROJECTOR	Screen cleaning	Weekly	11
	Check adjustments	Monthly	4, 7, 11
GAME BD	Setting check	Monthly	7
INTERIOR	Cleaning	Annually	see above.
POWER PLUG	Inspection and cleaning		
CABINET SURFACES	Cleaning	As necessary	see below

CLEANING CABINET SURFACES

If the cabinet is badly stained, use a cloth which is dipped in the chemical detergent liquid diluted with water and then suezzed dry. Do not use thinner, benzine, alcohol or chemical dustcloth as these can damage Cabinet surfaces.

## 14 . TROUBLESHOOTING

Should trouble occur, first check connector connections.

PROBLEMS	CAUSE	COUNTERMEASURES
With Main SW ON, no activation	Power is not supplied. Power supply/voltage is not correct. AC main fuse causes the power to be cut off due to momentary overload.	Plug in correctly Make sure that power supply/voltage is correct. Check fuse. Remove the cause of overload and replace fuse
Operation is unsatisfactory	Volume Setting Failure Poor mesh of V.R. gear. Spring failure due to secular change of Accelerator and brake mecha.	Perform Volume setting Adjust or replace V.R. Adjust Gear mesh.. Replace the Spring.
Irregular sound emitted from inside Rear Cabinet	Greasing to gear mesh portion is not satisfactory, or extraneous matter mixed in.	Apply greasing or eliminate extraneous matter.
The color of the image on PROJ. screen is incorrect.	Connector connections are defective.	Check the connection for the RGB and SYNC connectors of the PROJ. TERM. BD and VPM BUFFER BD.
The image on PROJ. screen has color deviation.	Affected by the magnetic field of installation location.	Make CONVERGENCE adjustment. (Refer to Section 9.)
No sound is emitted.	Sound Volume adjustment is not appropriate. Sound BD and speaker are malfunctioning.	Adjust sound volume. (see Section 6). Perform sound test to find and replace defective parts.(Refer to Section 6).
NETWORK check will not finish.	Communication cable's connection failure.	Perform V.R. setting, Adjustment.
Communication play is not possible.	Communication cable's connection failure. Communication Play setting is wrong.	Check for Communication cable disconnection Correctly set in test mode.
No sound from Vibration Mecha.	In correct Cabinet Type Setting.	Correct Cabinet Type Setting.
The Fluorescent lamp does not light up.	The Fluorescent tube is burnt out.	Replace the Fluorescent tube (Refer to Section 10).
Shift operation is not satisfactory in Manual transmission.	Shift SW malfunctioning.	Replace SW

## 14 - 1 REPLACEMENT OF FUSE



WARNING!

- In order to prevent an electric shock, be sure to turn power off before performing work by touching the interior parts of the product.
- Be careful so as not to damage wirings. Damaged wiring can cause an electric shock or short circuit accident
- After eliminating the cause of the blowing of fuse, replace the fuse.  
Depending on the cause of the fuse blowing, using the fuse as is blown can cause generation of heat resulting in fire.

Take out the truss screws and remove the back door to replace fuse.

Truss Screw (2) Black  
M4x25

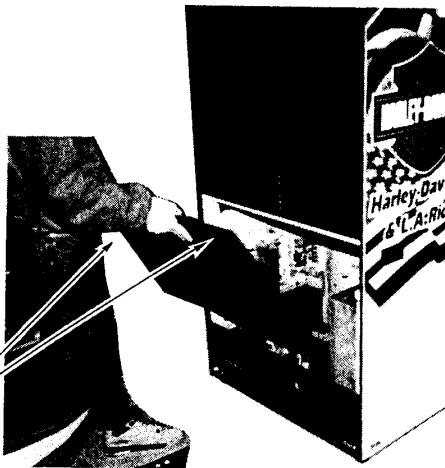

FUSE

514-5036-8000

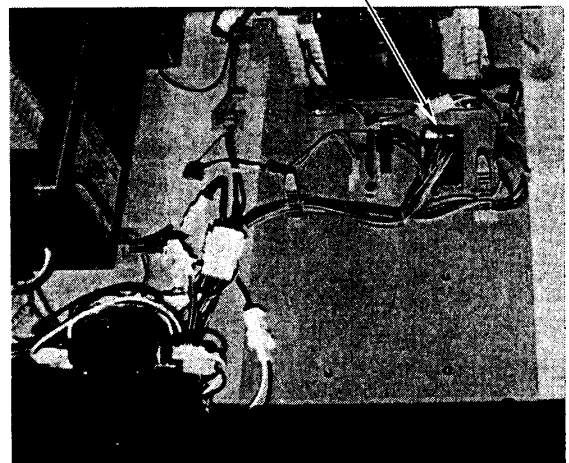

## 15 . GAME BOARD



WARNING!

- In order to prevent an electrical shock, be sure to turn power off before performing work by touching the interior parts of the product.
- Be careful so as not to damage wirings. Damaged wiring can cause an electric shock or short circuit accident.



CAUTION!

Do not expose the Game BD, etc. without a good reason. In this product, setting changes are made during the test mode. The Game BD need not be operated. Use the Game BD, etc. as is with the same setting made at the time of shipment.

### 15 -1 REMOVING THE GAME BOARD

- ① Remove the 2 screws which secure the Front Door.
- ② Unlock and remove the Front Door from the Cabinet
- ③ Disconnect all of the connectors connected to the Shield Case. (Blue 2P, Black 4P, Black 6P, White 8P, Black 10P, Black 12P, Red 12P, Blue 12P)

Screw (2)  
M4x30, flat washer used

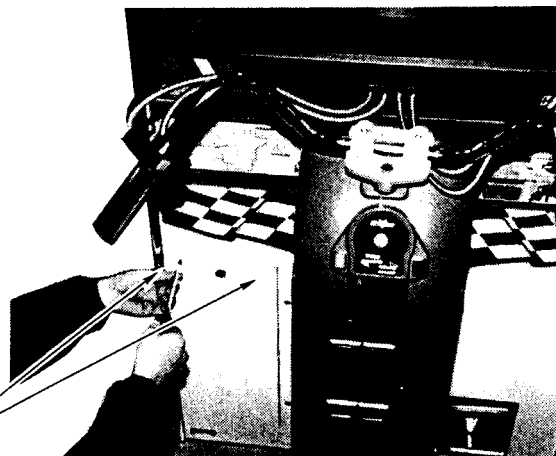

CONNECTOR (8)

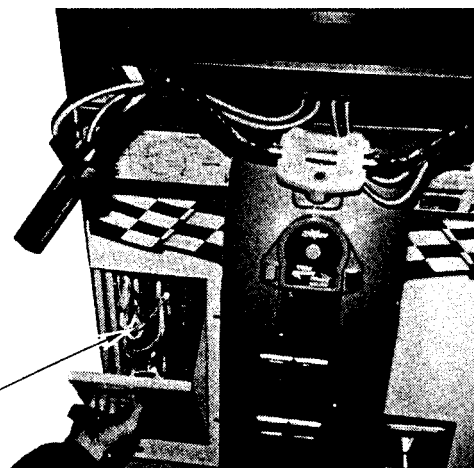

- ④ Remove the truss screws from the wooden base on which the Shield Case is mounted.

SCREW (2)  
M4x25

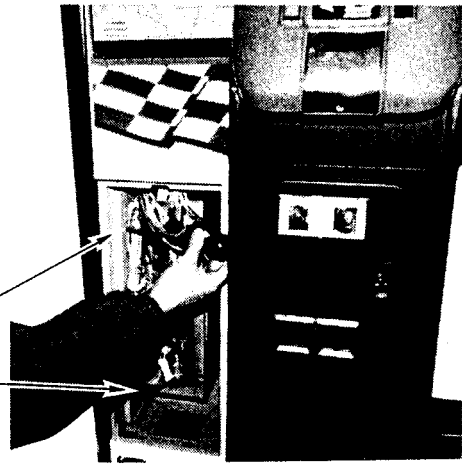

- ⑤ Withdraw the base from the cabinet together with the Shield Case as is mounted.

SHIELD CASE

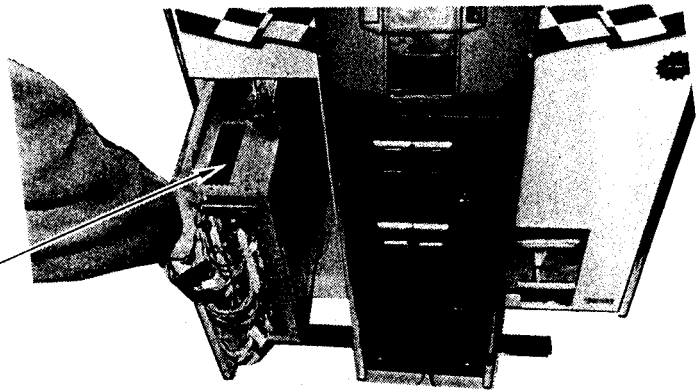

- ⑥ Remove the 3 screws, take out the Shield Case Lid and the Game Board will appear.

SCREW (3)

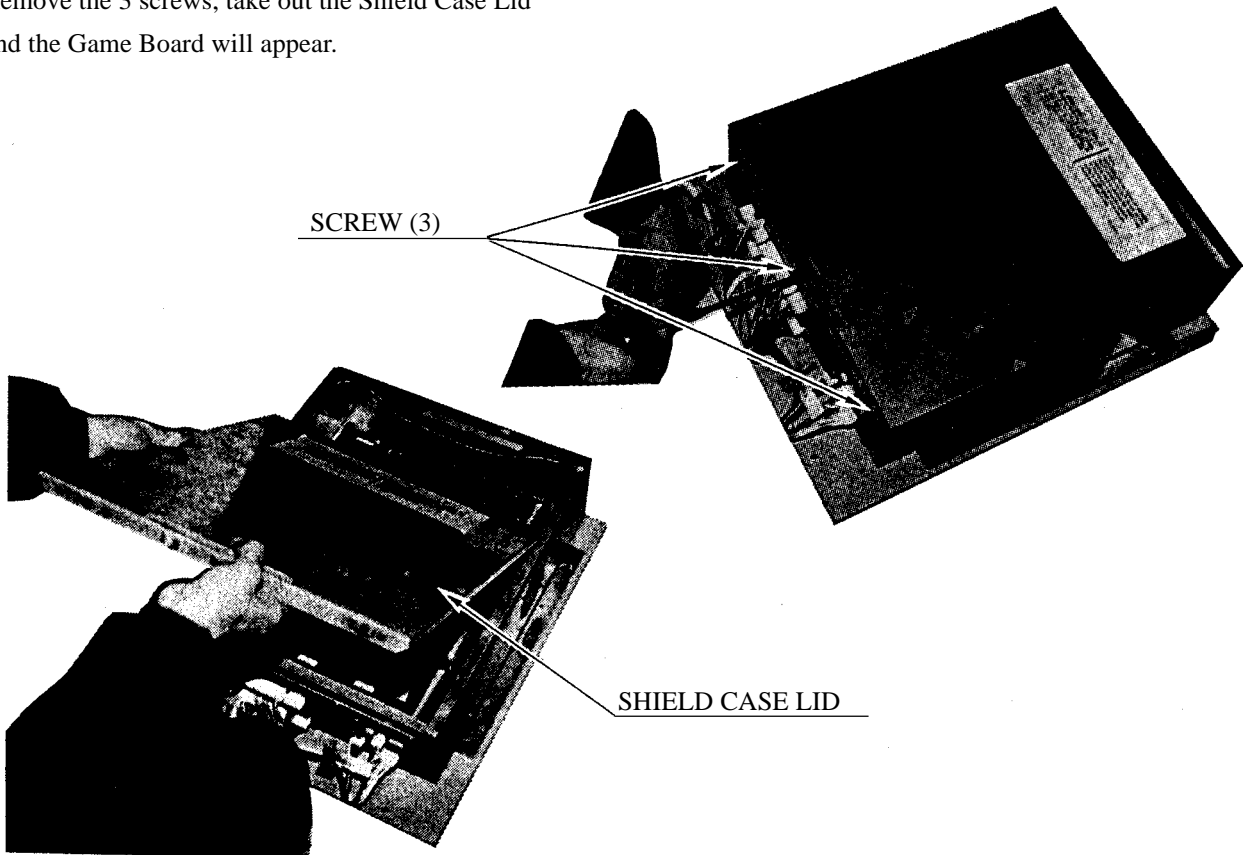

SHIELD CASE LID



# 15 - 2 COMPOSITION OF GAME BOARD

## GAME BD HARLEY DAVIDSON (833-13325)

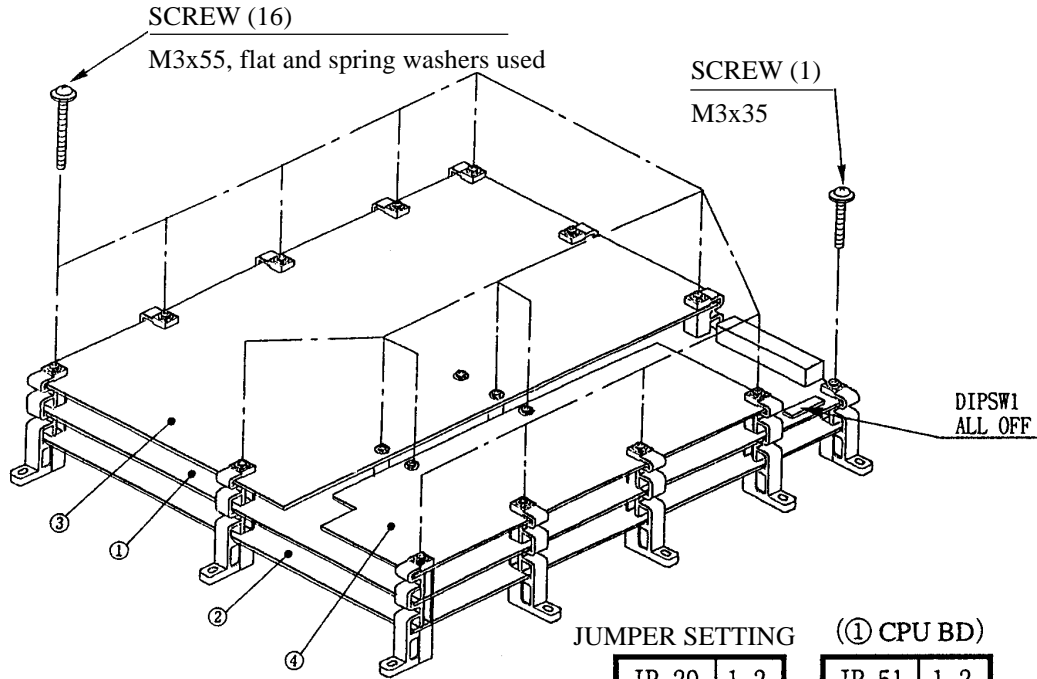

### JUMPER SETTING

(① CPU BD)

JP 29	1-2
JP 30	1-2

JP 51	1-2
JP 52	1-2
JP 53	1-2

## ROM BD HARLEY DAVIDSON (834-13326)

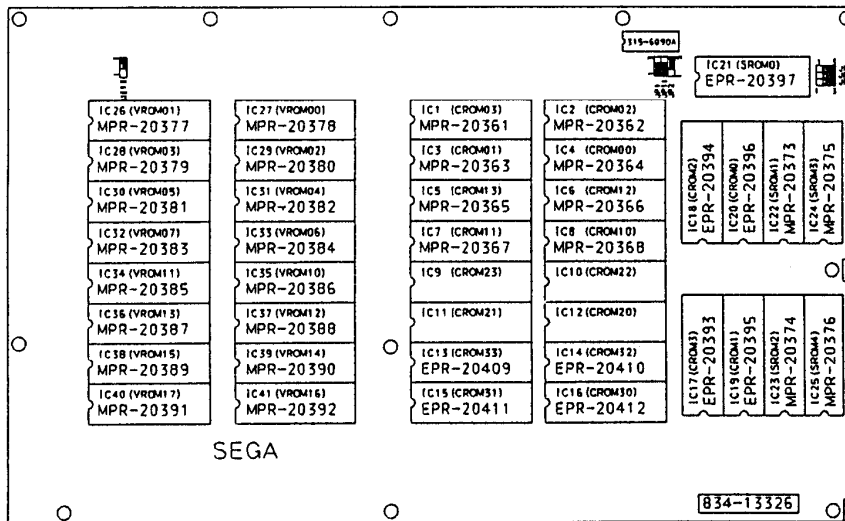

No.	PART No.	DESCRIPTION
①	837-12715	MODEL3 STEP2 CPU BOARD
②	837-12716	MODEL3 STEP2 VIDEO BOARD
③	834-13326	ROM BD HARLEY DAVIDSON
④	837-11861-91	MODEL3 COMM BD COM

NOTE: THIS PICTURE IS FOR REFERENCE ONLY!! UNIT IS NOT TO BE OPENED. EXPOSING THE GAME BD FOR ANY REASON MAY VOID WARRANTY.

## 16. COMMUNICATION PLAY



WARNING!

Before performing between-cabinets connection work, be sure to turn the Power SW OFF and unplug the power plug from the wall socket. Failure to observe this can cause electric shock and/or short circuit accidents.

Perform assembling as shown in this manual. Erroneous assembling can cause electric shock accidents and malfunctioning.

By linking 4 machines, up to 4 persons can play simultaneously. Although accessory parts are to be installed for communication play, some of the parts will remain as spares.

### 16 - 1 INSTALLATION PRECAUTIONS

- ① Simple multiple machines are to be linked, sufficient power corresponding to the number of machines used need to be supplied. As standard, amperage is 7A (AC100~110~120V area).
- ② Due to the parts used for communication play, interval between machines is 20 cm. If parts are not installed, adjacent players will come into contact with each other and this can cause accidents and trouble.

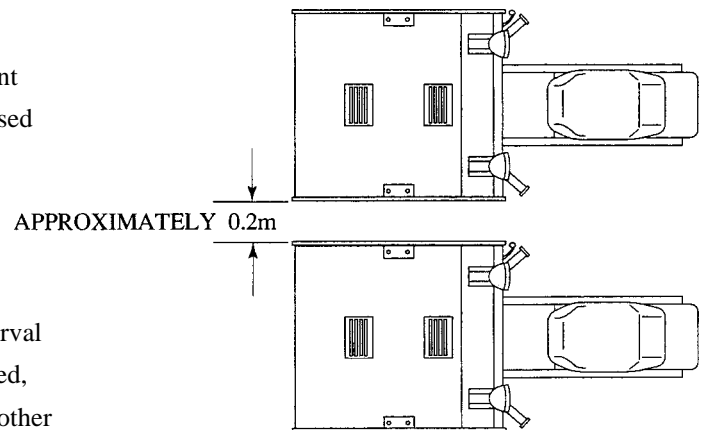

### 16 - 2 CONNECTING THE COMMUNICATION CABLES



IMPORTANT!

The Communication Cable is optic-fiber made and will break if excessively bent. Handle with care.

Connect machines with the protective tube and pass the communication cable in the tube. Depending on the number of machine units to be linked, connect the communication cables (optic-fiber cables) in a manner shown in the following figures.

- ① Take out the 2 screws and remove the Back Door.

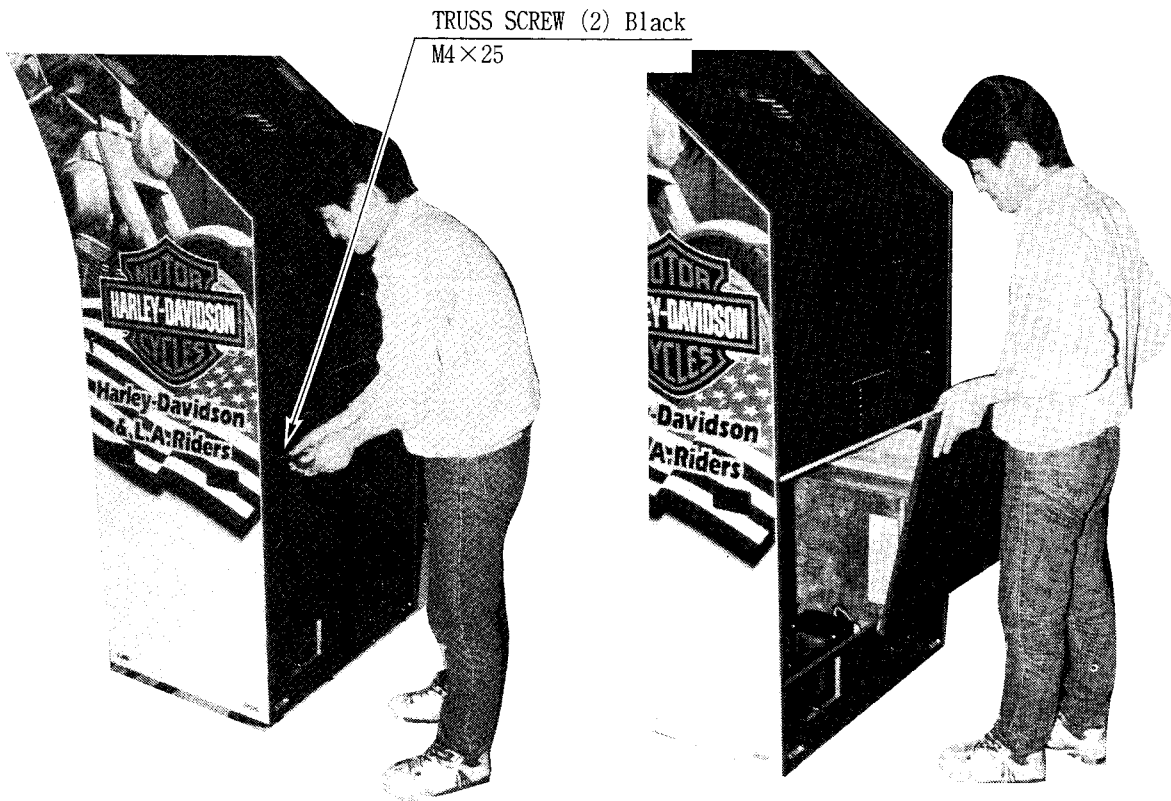

- ② Take out the 4 screws and remove the Fiber Lid Base.

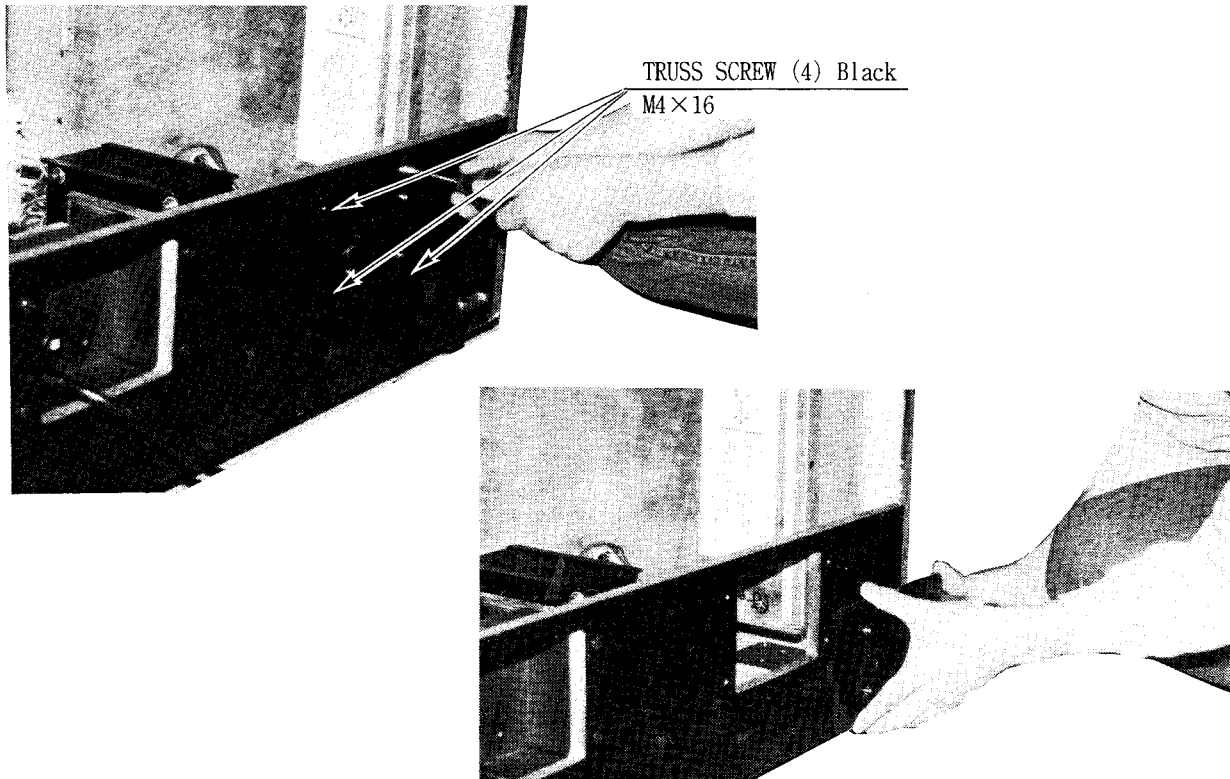

③ Loosen the screw and turn the Fiber Lid so as to install Connector 29 to the Fiber Lid Base. Take out the nut from Connector 29 and insert Connector 29 into the Fiber Lid Base hole, then fasten the nut to secure.

④ Insert Protective Tube to Connector 29. With a click sound, the tube is secured to the connector.

After securing Connector 29, secure Fiber Lid with the screw.

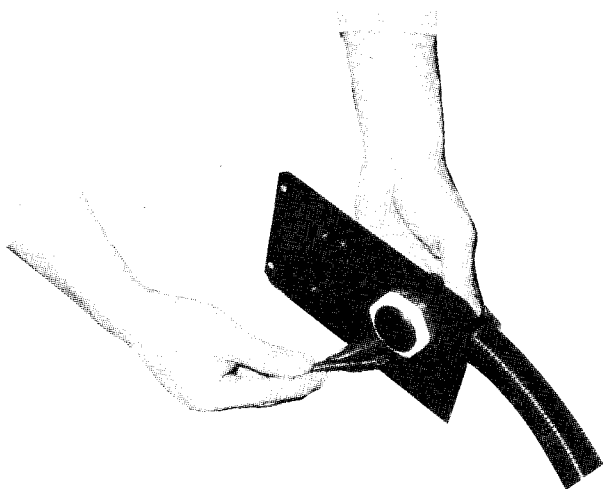
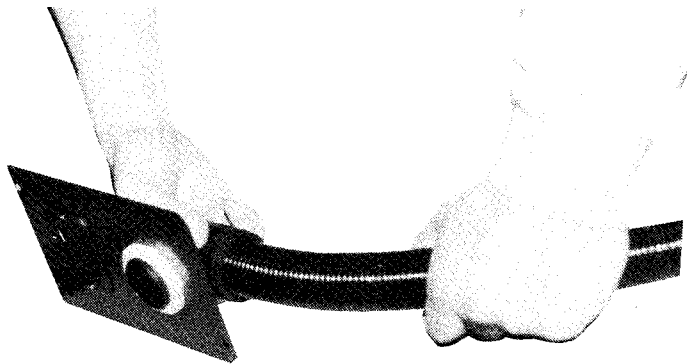
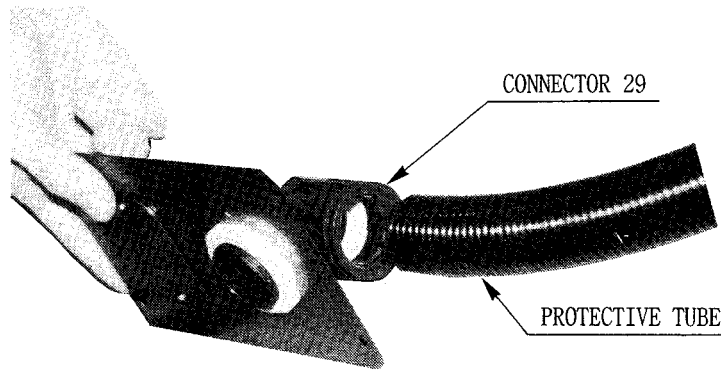
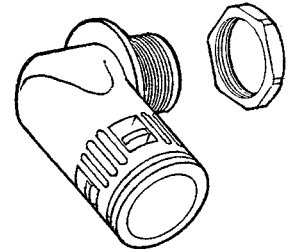
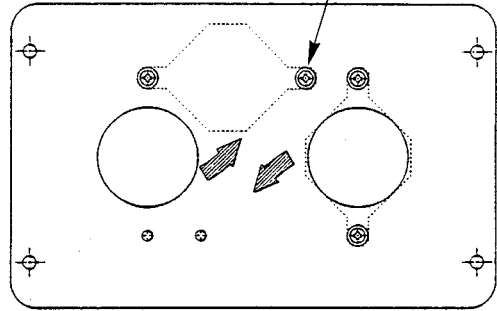

⑤ Pass the communication cable through the Protective Tube.

- ⑥ Reinstall Fiber Lid to the original position.

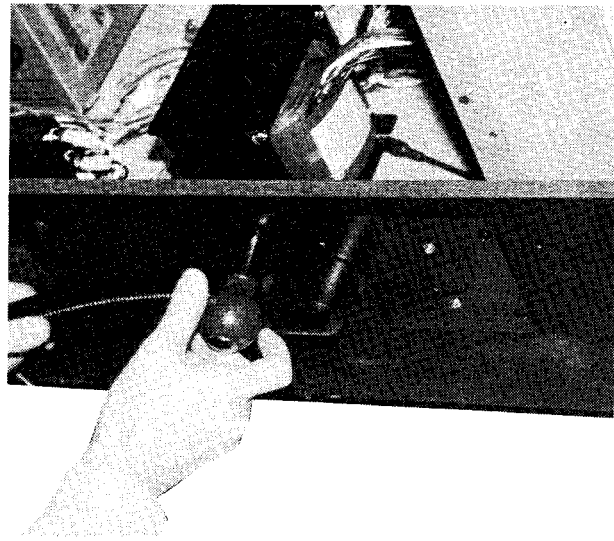
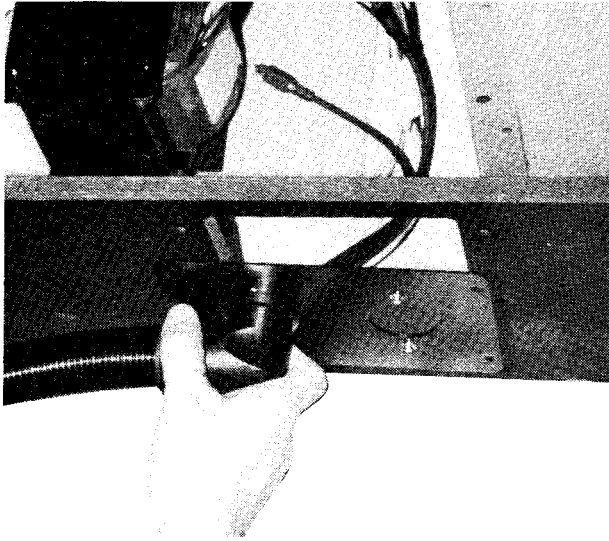

- ⑦ Take out the 2 screws, unlock and remove the Front Door, and the Shield Case appears. the communication cable insertion connector is with the Filter Board in front of the Shield Case. Take off the Cap from the connector and insert the communication cable.

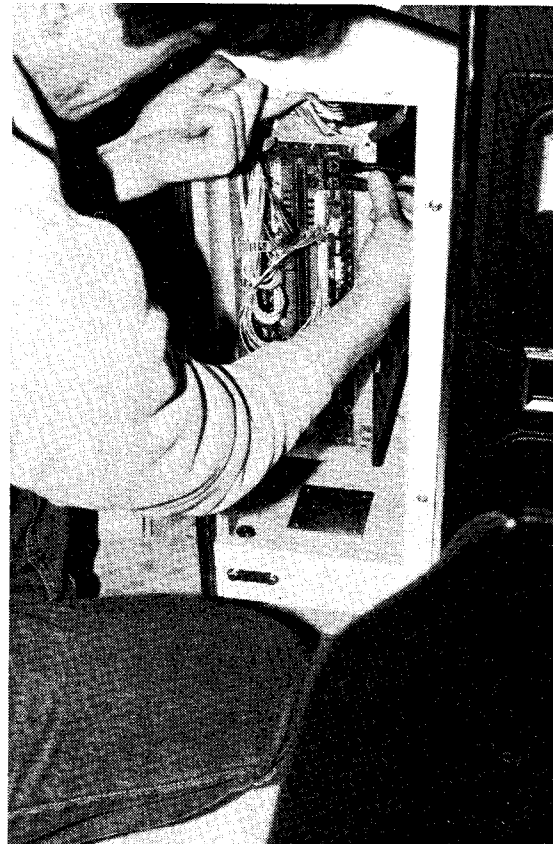

EXAMPLE OF HOW CABINETS SHOULD BE SET UP FOR COMMUNICATION PLAY

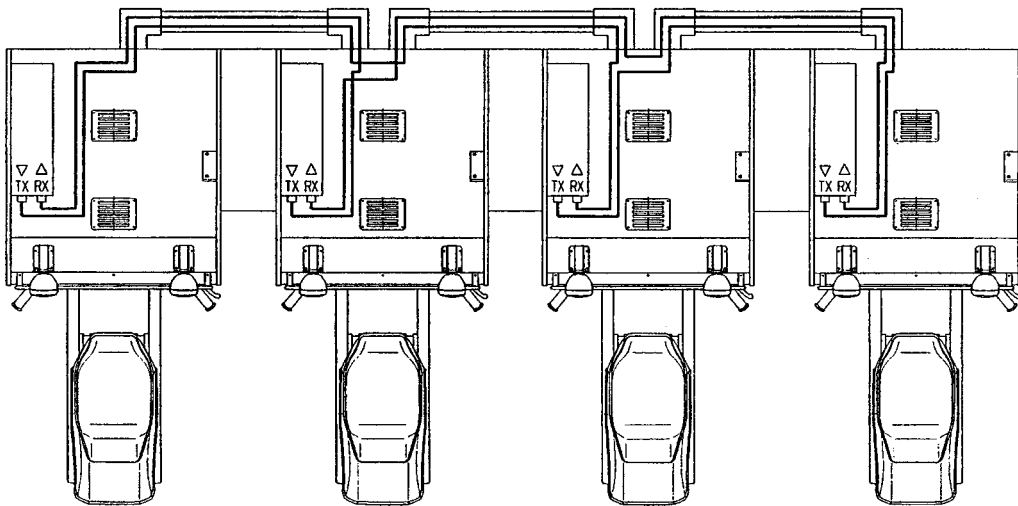
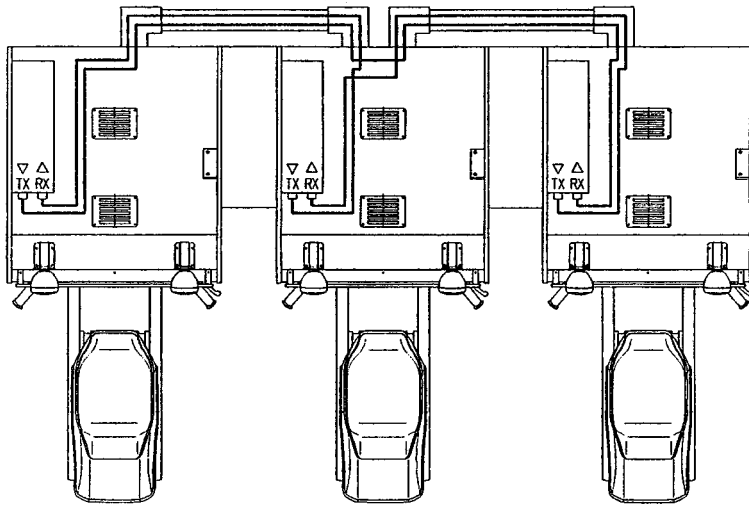
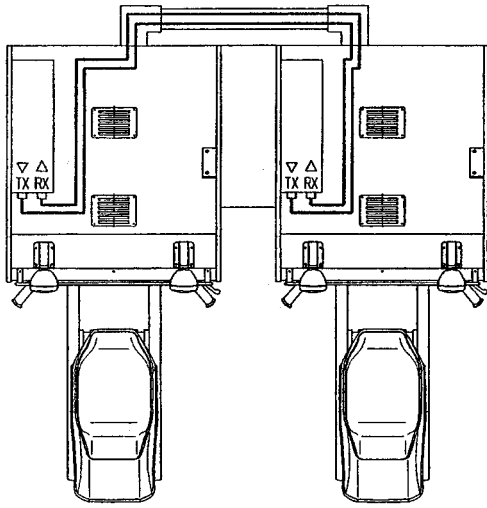

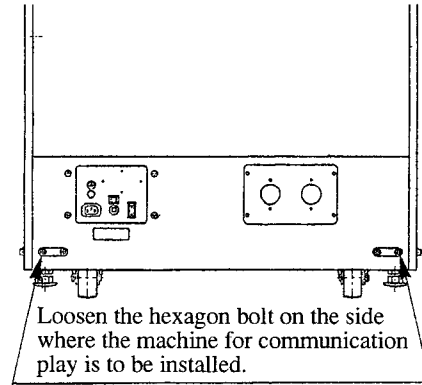
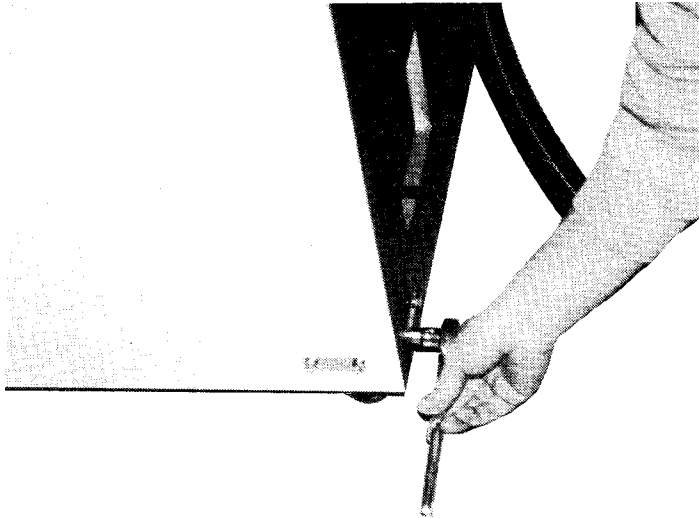

Install joint parts used to join interactive play machines together.

- ⑧ Loosen the hexagon bolt on the lower rear of the cabinet. Loosen the hexagon bolt on the side where machines are to be linked for communication play.
- ⑨ Insert the notch portion of the lower joint to the loosened hexagon bolt and retighten the hexagon bolt.

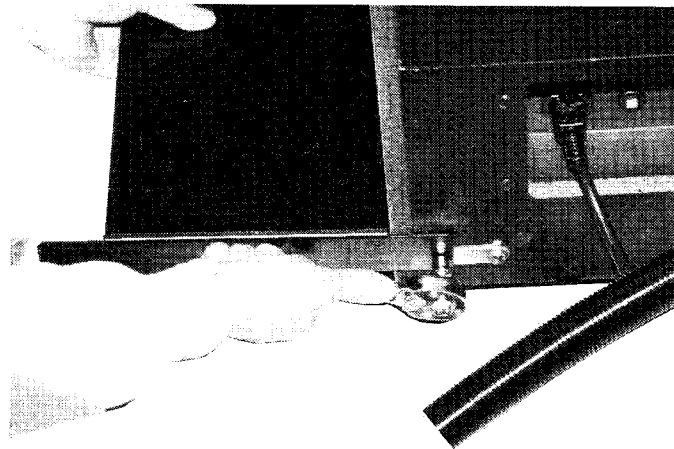
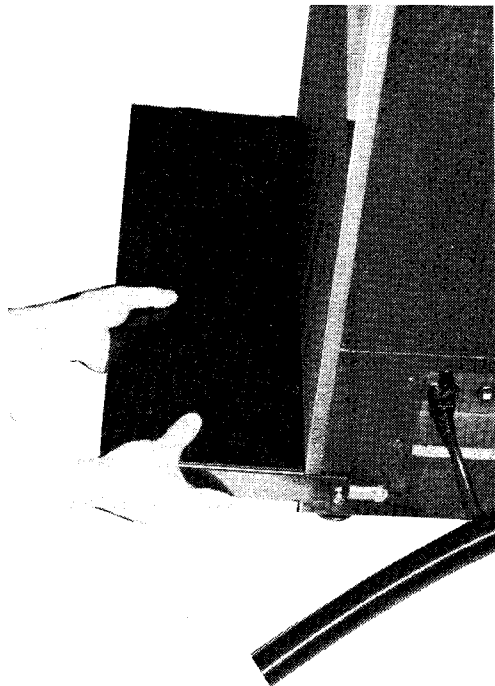

⑩ As in the rear of the cabinet, loosen the hexagon bolt of the side where the lower joint in front of the cabinet is to be installed.

⑪ Insert the Joint Plate's notch portion to the loosened hexagon bolt and retighten the hexagon bolt. At this time, align the Joint Plate's hole and the lower joint's screw hole, then retighten the hexagonal bolt.

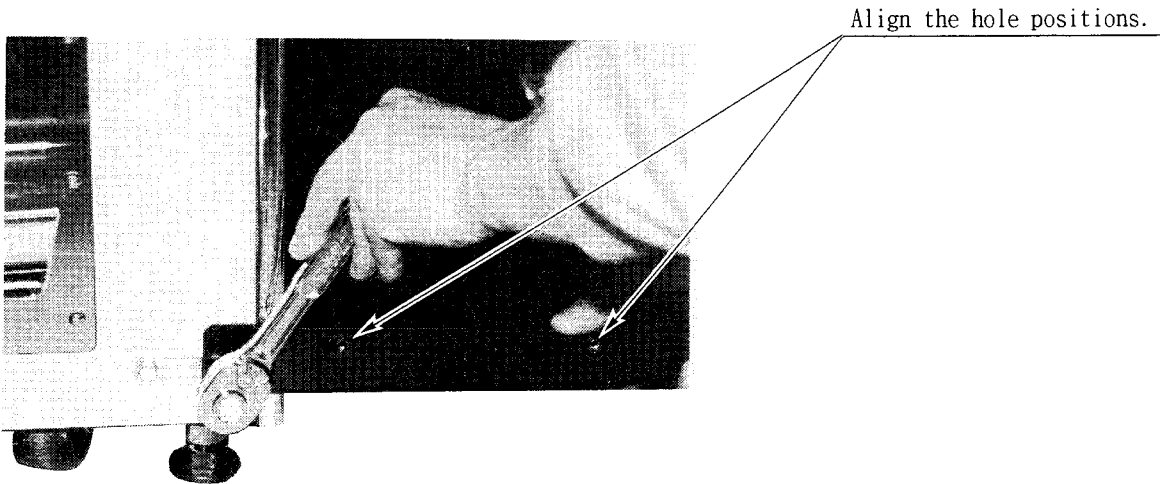
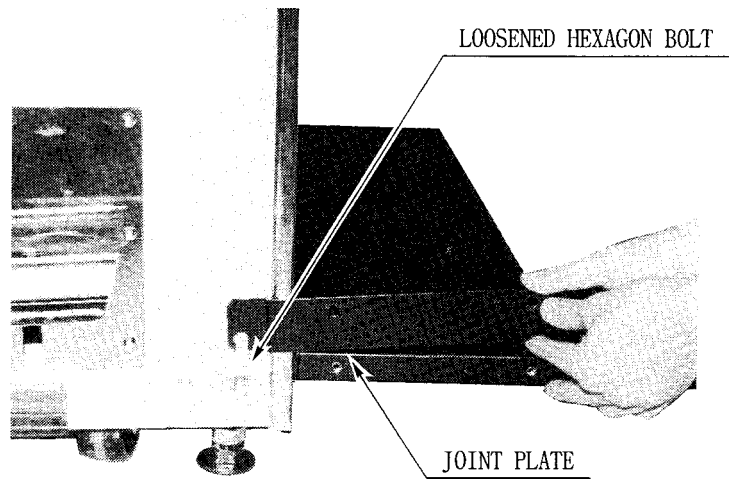

⑫ Secure the joint Plate and Lower Joint with the 2 hexagon bolts.

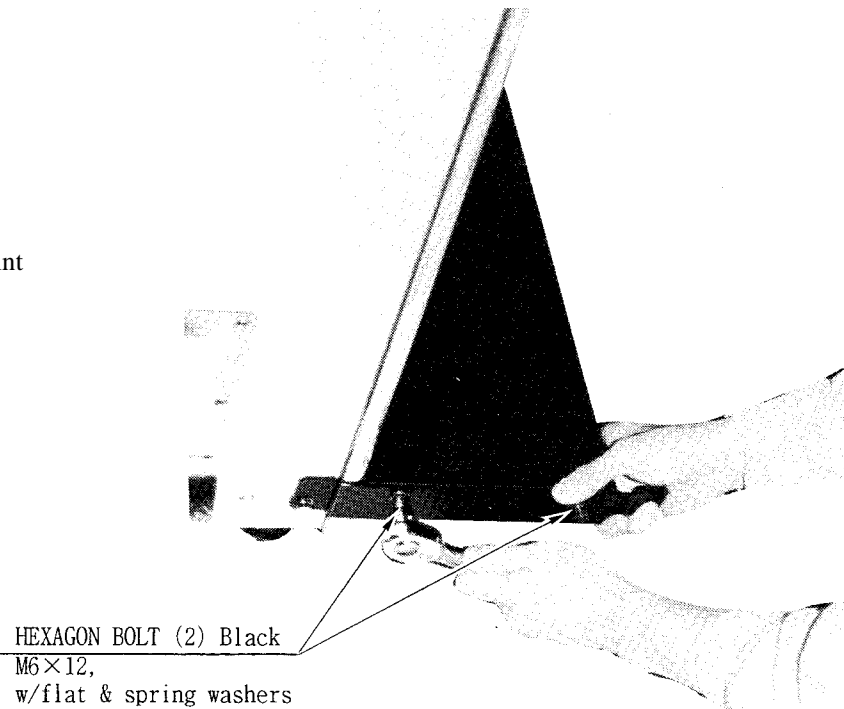



- ⑬ Remove the Shipping Hook Bracket from the side where the Joint Parts are to be installed.

SHIPPING HOOK BRACKET

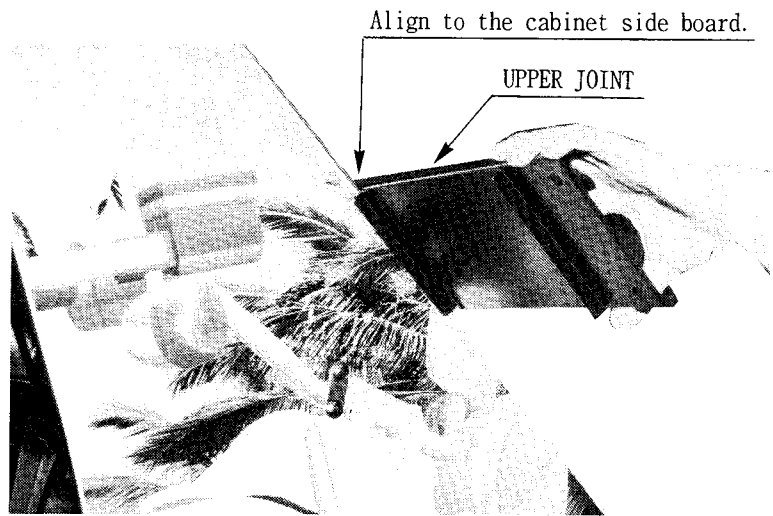
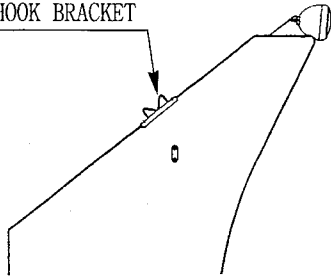

- ⑭ Secure the Upper joint by using the 2 hexagon bolts which secured the Shipping Hook Bracket.

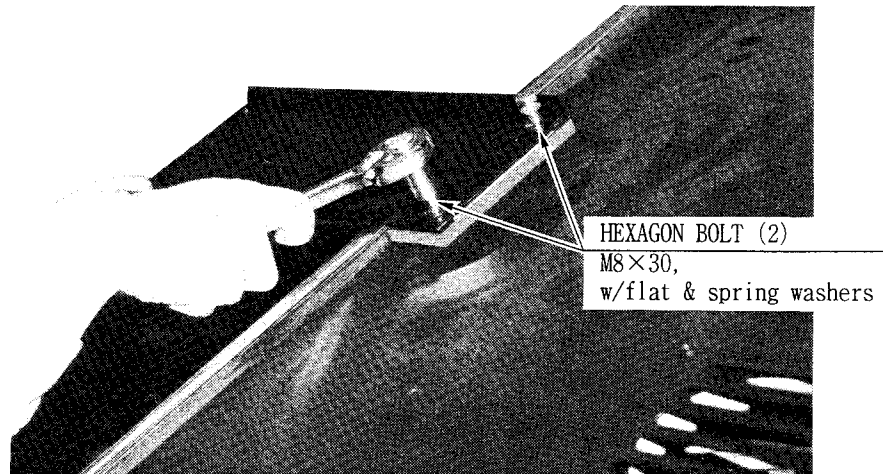

- ⑮ Remove the 2 screws out of a total of 4 screws, which secure the Lamp Holder, from the rear side and utilize these to install the POP HOLDER.

POP HOLDER

TRUSS SCREW (2) chrome  
M4 x 16

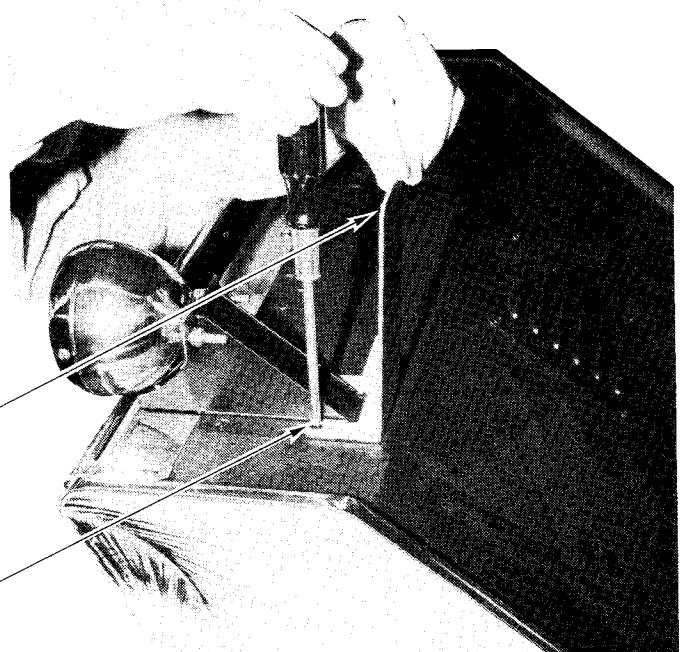

- ⑩ In the similar manner shown as on the previous page, connect the communication cable for the other machine and install joint parts.
  
- ⑪ By using 2-sided tape, install the POP PANEL to the POP HOLDER installed for the adjoining machines.

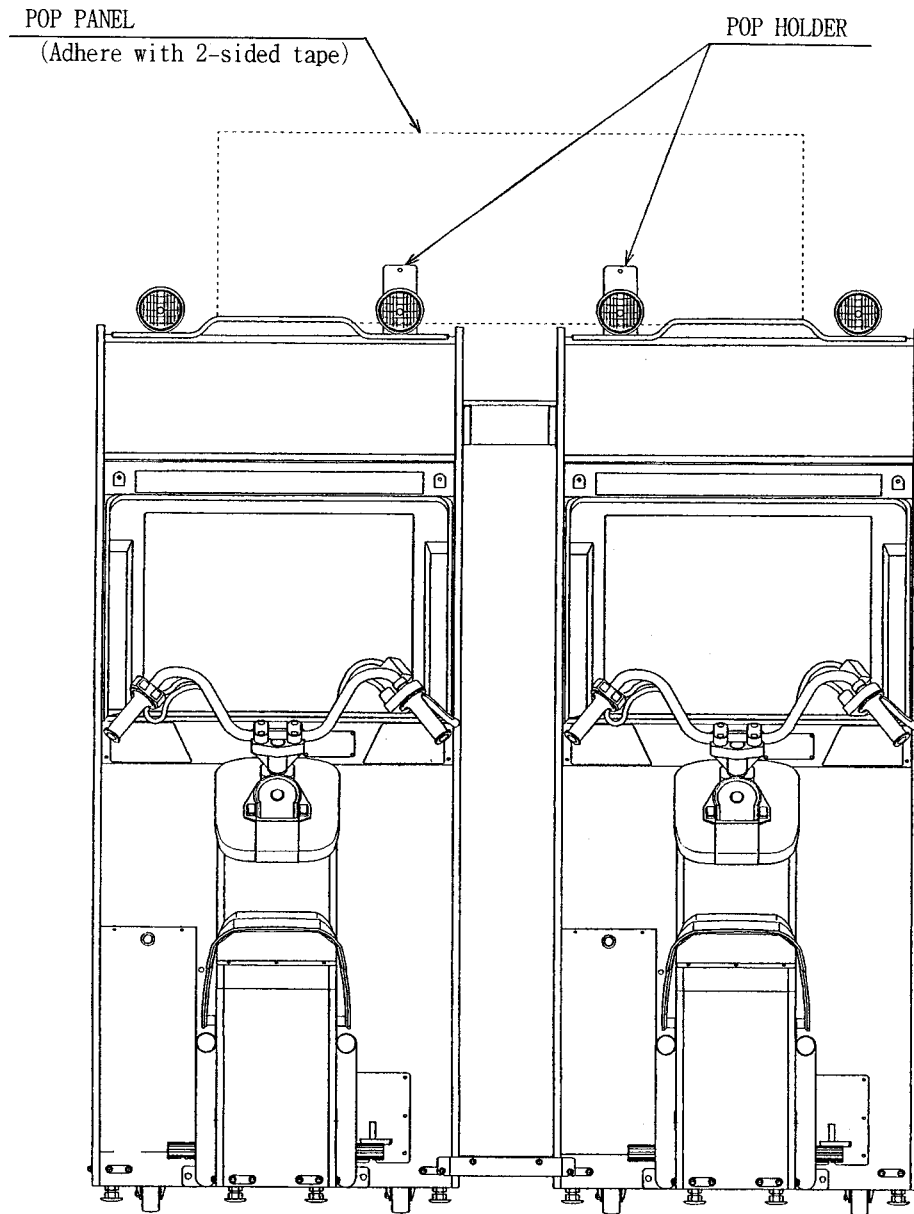



IMPORTANT!

During communication play, if communication is interrupted due to a certain cause, ERROR MESSAGE will be displayed, then NETWORK check mode appears on the screen automatically.

Cause all of the seats to enter the Test Mode and change the NETWORK ASSIGNMENTS of each seat for communication play. For the Changing procedure, refer to the explanations of Section 7.

- ① Press the TEST button to enter the test mode and choose “NETWORK ASSIGNMENTS”.
- ② Bring the arrow to COMMUNICATION and select “NETWORK”.
- ③ Bring the arrow to PRIVILEGE MODE and press the Test Button to set one of the plural seats (basically the leftmost seat) to “MASTER”. Set other seats to “SLAVE”
- ④ Bring the arrow mark to “CABINET ID NUMBER”, press the TEST BUTTON and set the seat number of the machines sequentially to No. 1, No. 2, No. 3, No. 4 as applicable starting from the extreme left facing the monitor’s front side. If the same number is for 2 or more cabinets, or if the sequential order is incorrect, the game display, etc. will be confused (different from the actual status). Therefore, be careful of this point.

In the case of communication play, all the settings other than CABINET TYPE, B.G.M. VOLUME, and ENGINE VOLUME from among the Game Assignments will be executed by the MASTER SEAT. All other seats (“SLAVE”) are subject to the setting change made by the “MASTER” seat.

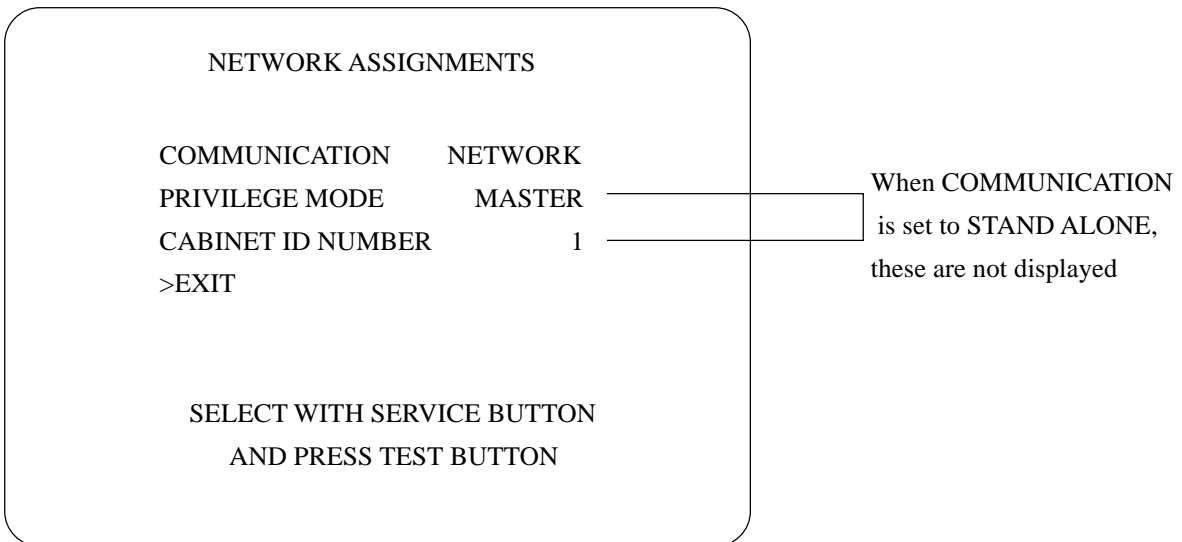

## 16 - 4 NETWORK CHECK

With the communication play setting, NETWORK check is executed when the power is turned on or the test mode is exited.

During the network check, the screen shown right will be displayed. If communication play setting and communication cable connection are correct, the Game mode (the ADVERTISE MODE) is displayed and the network check is finished.

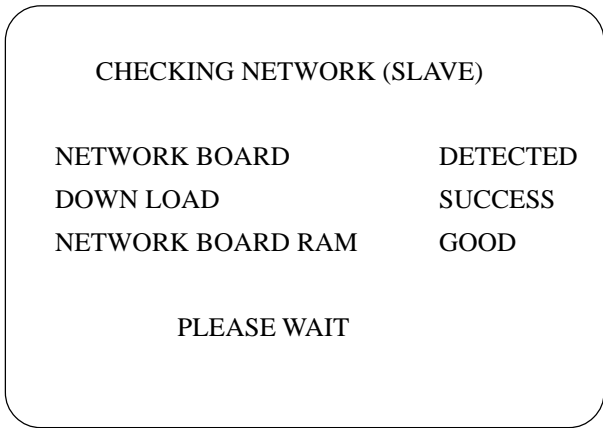

If communication play setting error or communication cable error is found, the screen shown right appears. Press the TEST BUTTON to enter the TEST MODE. Check and correct the communication play setting. Check communication cable connection by watching.

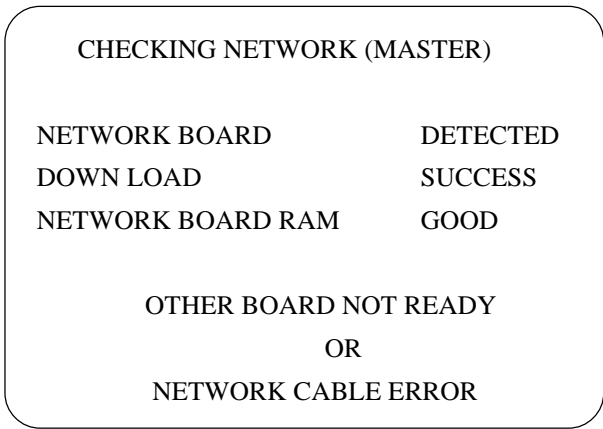

During communication play, if communication is interrupted due to a certain cause, the screen shown right will appear and then, network check starts automatically.

In the network check, if an irregularity such as the communication cable disconnection is detected, the screen shown right appears.

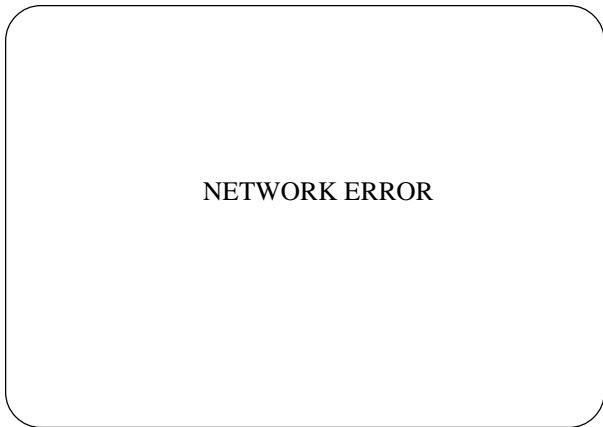

# 17 . DESIGN RELATED PARTS

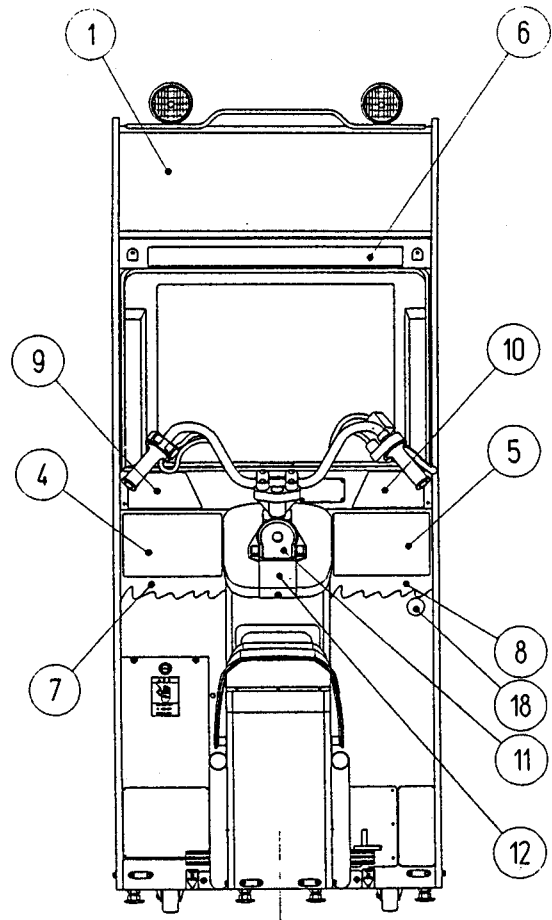
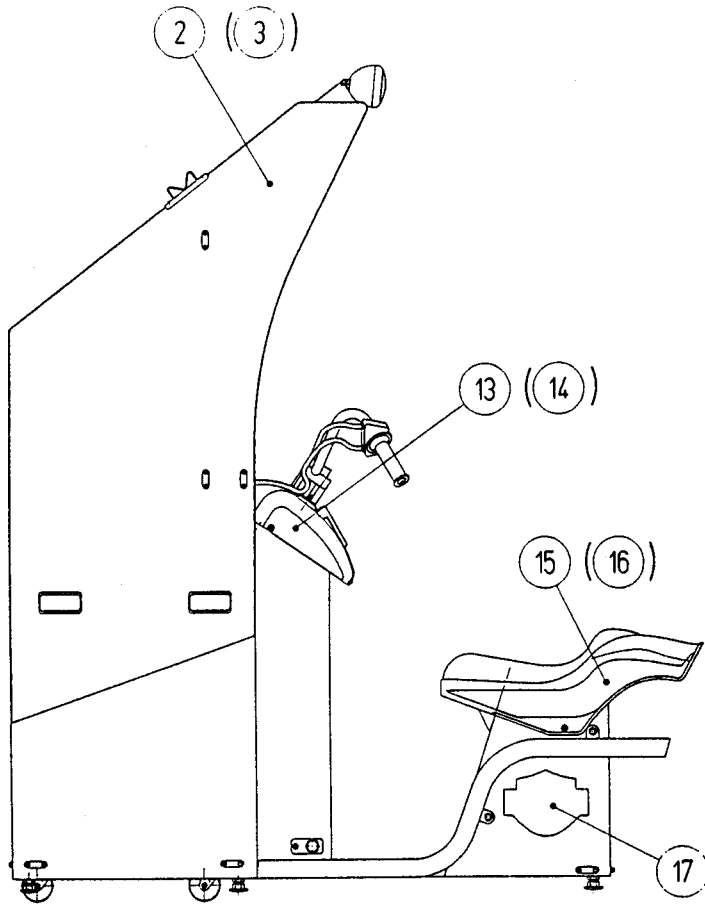

ITEM NO.	PART NO.	DESCRIPTION
1	4230-0318-91	BILLBOARD PLATE HLD STD
2	HLD0-1110X	STICKER CABI L
3	HLD0-1111X	STICKER CABI R
4	4220-0654	PLAY INSTR HLD STD A
5	4220-0655-91	PLAY INSTR HLD STD B
6	4220-0656-91	SUB INSTR HLD STD
7	HLD0-1117	STICKER CABI FRONT L
8	HLD0-1118	STICKER CABI FRONT R
9	HLD0-1104-A	STICKER MASK COVER L
10	HLD0-1104-BX	STICKER MASK COVER R
11	HLD0-1082-B	STICKER FUEL TANK A
12	HLD0-1082-C	STICKER FUEL TANK B
13	HLD0-1082-DX	STICKER TANK L
14	HLD0-1082-EX	STICKER TANK R
15	HLD0-3055-B	STICKER REAR FENDER L
16	HLD0-3055-C	STICKER REAR FENDER R
17	HLD0-3051-CX	STICKER BAR AND SHIELD
18	4210-9747	STICKER HLD CUP

# 18 . PARTS LIST

TOP ASSY HARLEY-DAVIDSON STD

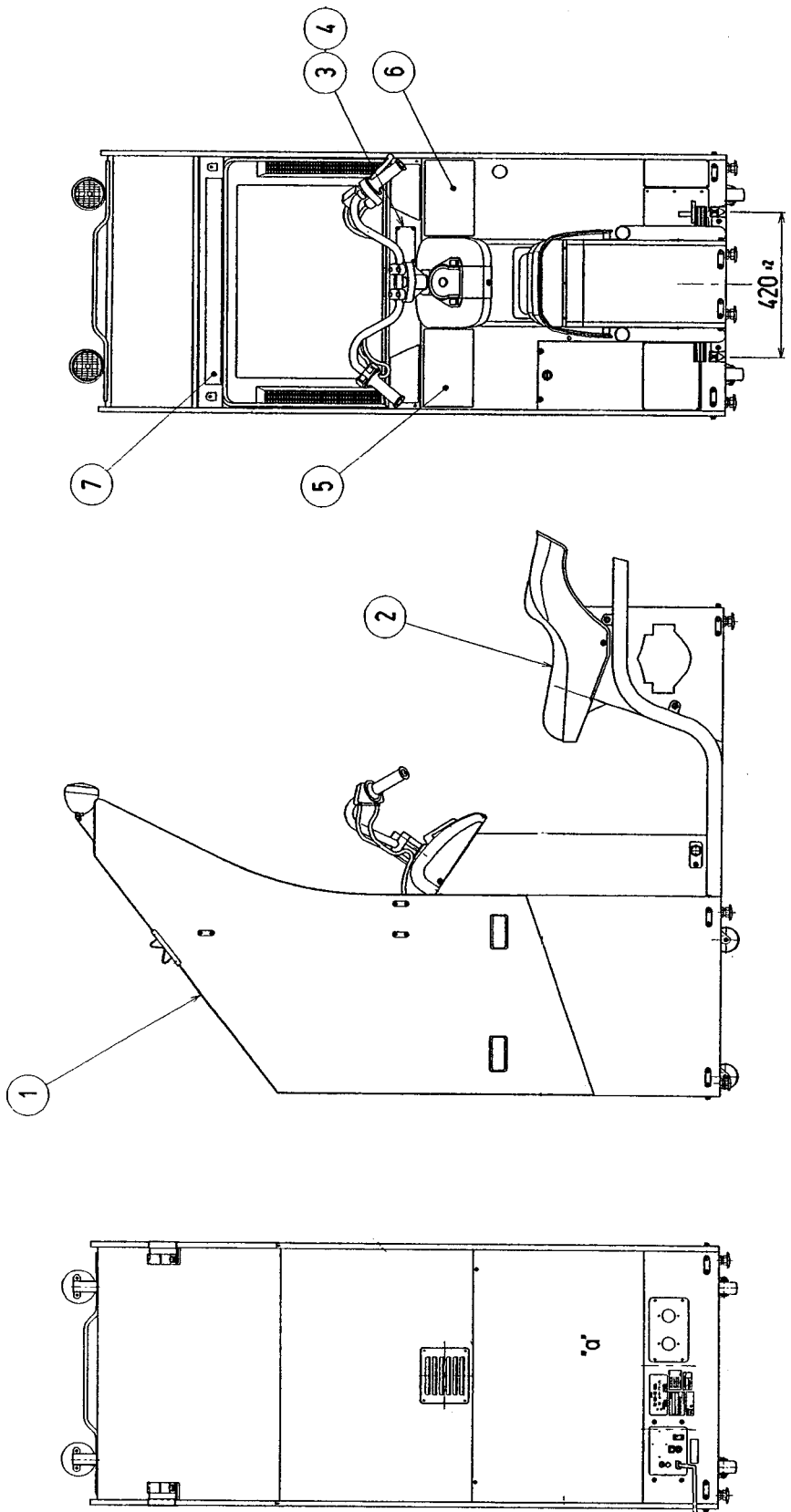

TOP ASSY HARLEY-DAVIDSON STD

<b>ITEM NO</b>	<b>PART NO.</b>	<b>DESCRIPTION</b>
1	HLD-10001	ASSY CABINET
2	HLD-3050	ASSY SEAT CABI
3	DYN-0011	DENOMI PLATE W/O ORIGINAL
5	422-0654	PLAY INSTR HLD STD A
6	422-0655-01-91	PLAY INSTR HLD STD B ENG
7	422-0656-91	SUB INSTR HLD STD

ASSY CABINET (HLD-10001)

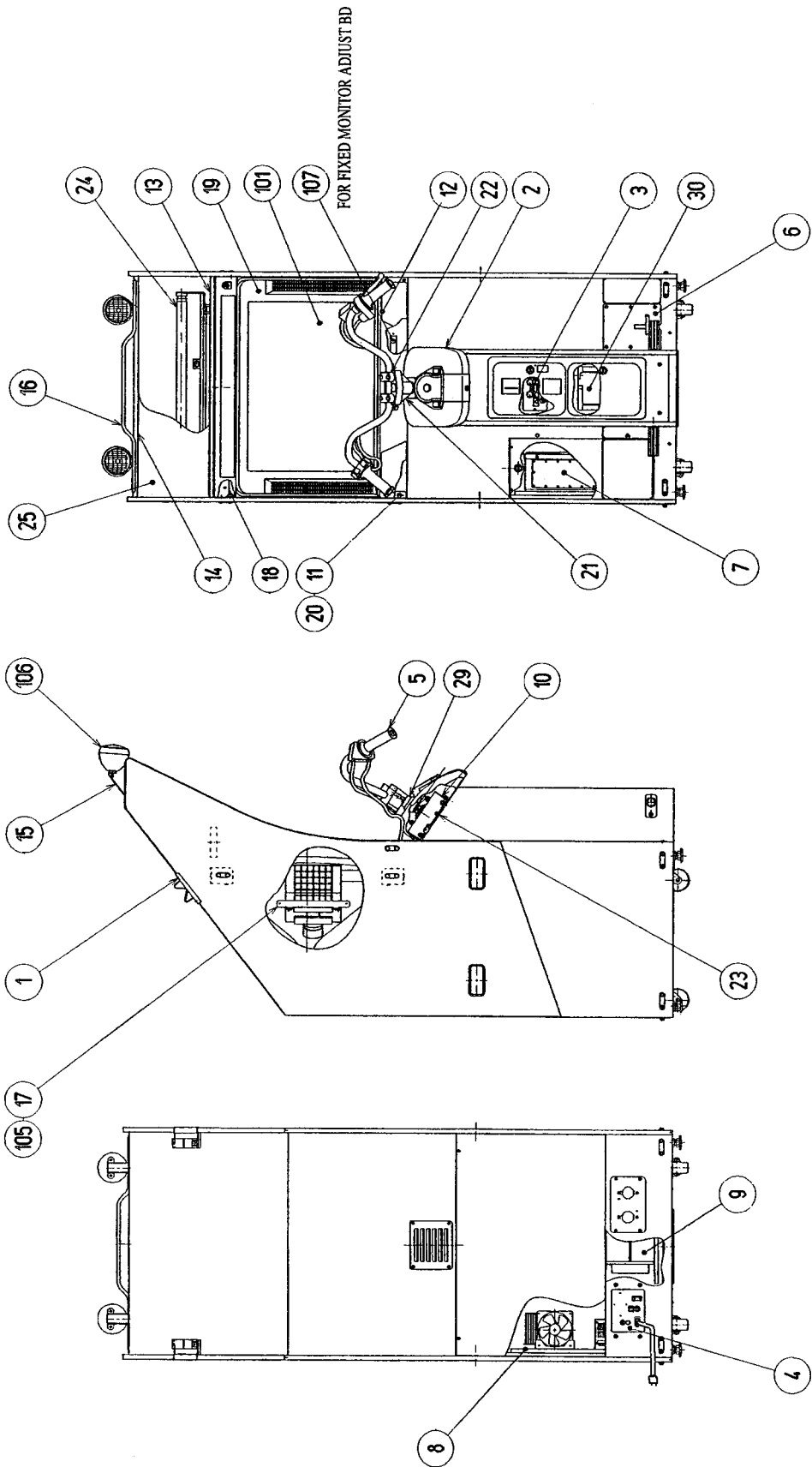



ASSY CABINET (HLD-10001)

ITEM NO.	PART NO.	DESCRIPTION
1	HLD-1100	ASSY SUBCABI STD
2	HLD-1080	ASY FUEL TANK
3	HLD-1090	SW UNIT
4	DYN-1080	AC UNIT
5	HLD-2000	ASSY HANDLE
6	HLD-2800	ASSY FOOT BRAKE MECHA
7	HLD-4700	ASSY MAIN BD STD
8	HLD-4500	ASSY ELEC
9	HLD-4600	ASSY POWER SUPPLY
10	MJT-3650	ASSY CENTERING MECHA
11	HLD-1103	MASK HOLDER LOWER
12	HLD-1104	MASK COVER
13	HLD-1105	SASH LOWER
14	HLD-1106	SASH UPPER
15	HLD-1107	LAMP HOLDER
16	HLD-1108	LAMP FRAME
17	HLD-1109	SP BRKT
18	GBN-1076	MASK SUPPORT
19	TTR-1067X	MONITOR MASK
20	117-5235	PLATE 6-30
21	MJT5-3603	MOUNT BLOCK
22	MJT5-3612	HANDLE HOLDER
23	HLD-1116	TANK BASE
24	HLD-1130	ASSY FL
25	423-0318-91	BILLBOARD PLATE HLD STD
29	MJT-3005	CALLAR
30	253-5366	CASH BOX
32	HLD-1126	GUARD PLATE
33	HLD-1127	CUSHION
101	200-5243-24	ASSY CLR DSPL 29 TYPE 24K 100V
102	280-5112	BUSH FOR TV
103	280-5113	COLLAR FOR TV
104	280-5114	SPACER 6.4-25X2
105	130-5152	SPKR BOX MINI DOME
106	3901-5753	ASSY LAMP 24V 20W
107	280-5185-15	SPACER TUBE L=5

ASSY SUB CABI STD (HLD-1100)

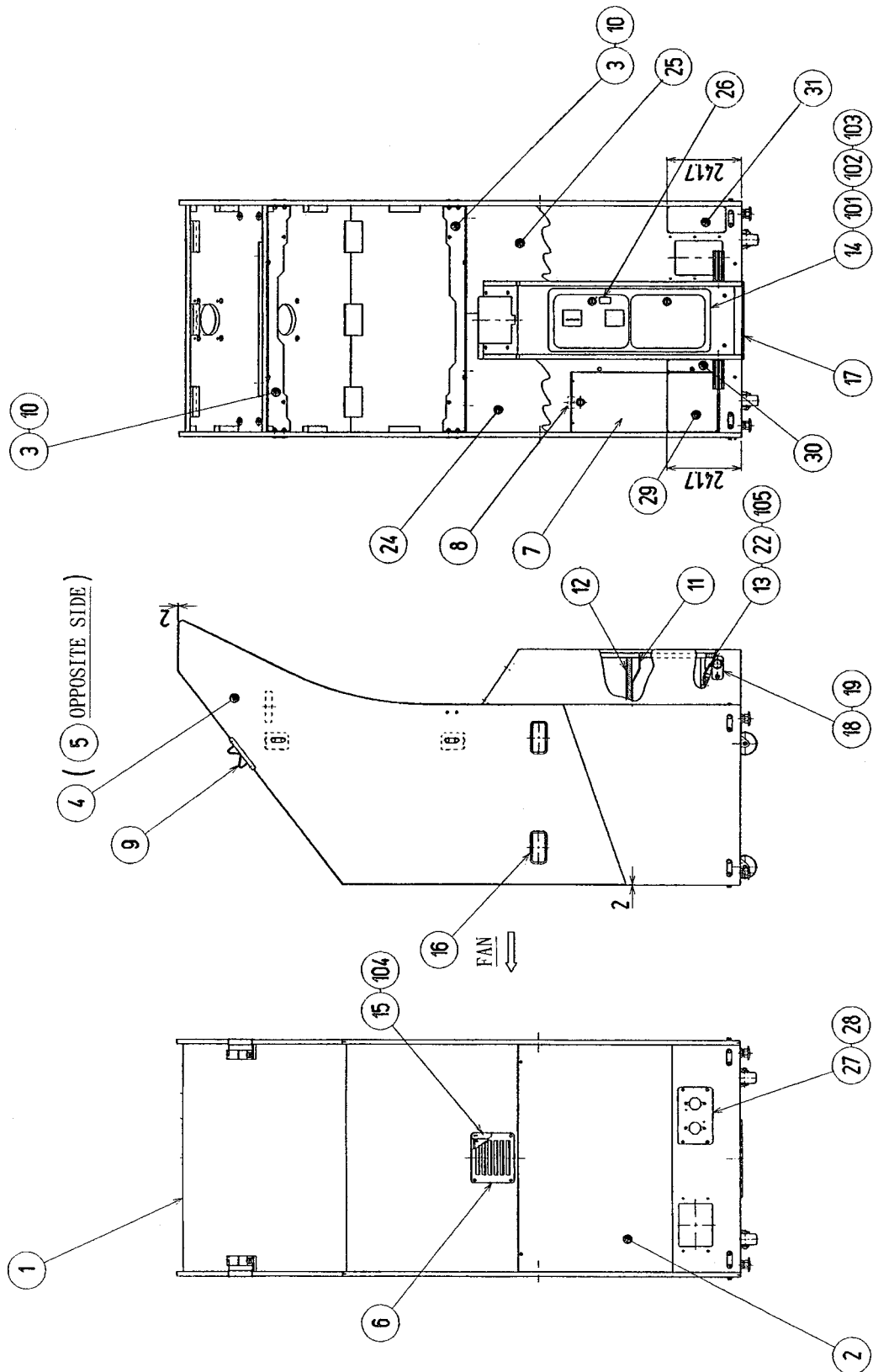

ASSY SUB CABI STD (HLD-1100)

ITEM NO.	PART NO.	DESCRIPTION
1	HLD-1101	WOODEN CABINET
2	HLD-1102	BACK DOOR
3	GBN-1074X	MONITOR SUPPORT
4	HLD-1110X	STICKER CABI L
5	HLD-1111X	STICKER CABI R
7	HLD-1120	ASSY FRONT DOOR
8	117-5098	TNG RETAINER PLATE
10	117-5235	PLATE 6-30
11	105-5169	LOCK BRKT W
12	105-5171	CHUTE PLATE SINGLE
13	HLD-1112	METER BRKT
14	DP-1167	TNG LKG
15	HN-1042X	FAN BRKT
16	253-5396-91	CABINET HANDLE
17	HLD-1113	JOINT HOLDER
18	HLD-1114	FOOT REST
19	HLD-1115	STEP RUBBER
24	HLD-1117	STICKER CABI FRONT L
25	HLD-1118	STICKER CABI FRONT R
27	HLD-1119	FIBER LID BASE
28	HLD-1122	FIBER LID
29	HLD-1123	FOOT COVER A
30	HLD-1124	FOOT COVER B
31	HLD-1125	FOOT COVER C
101	SEE DESCRIPTION	ASSY COIN DOOR
104	260-0011-02	AXIAL FLOW FAN AC 100V 60-60Hz
105	220-5412	MAG CNTR W/CONN

ASSY FRONT DOOR (HLD-1120)

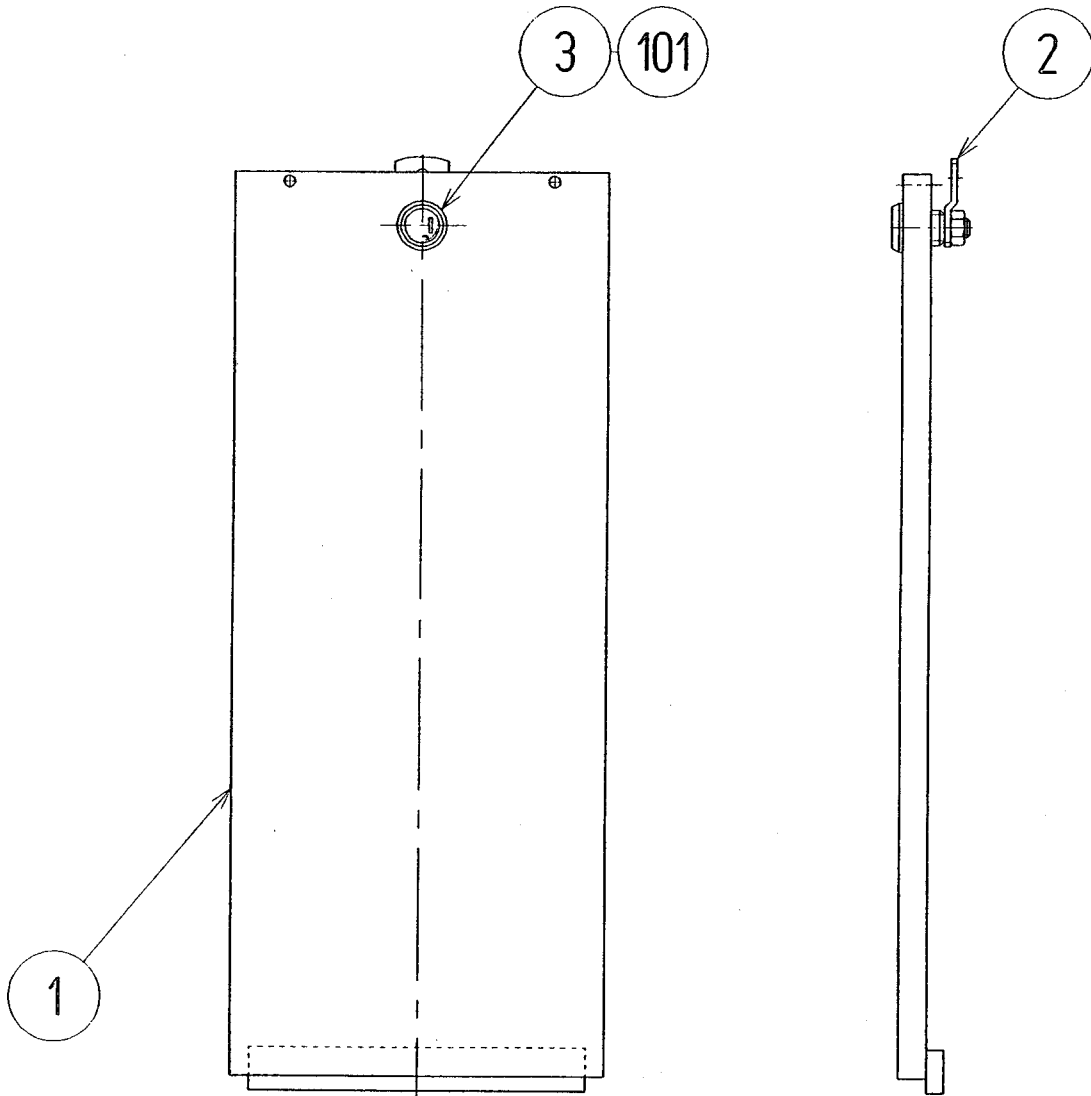

ITEM NO.	PART NO.	DESCRIPTION
1	HLD-1121	FRONT DOOR
2	DP-1148X	LKG TNG
3	117-0062	PLATE LOCK RETAINER
101	220-5575	CAM LOCK MASTER W/O KEY

ASSY FUEL TANK (HLD-1080)

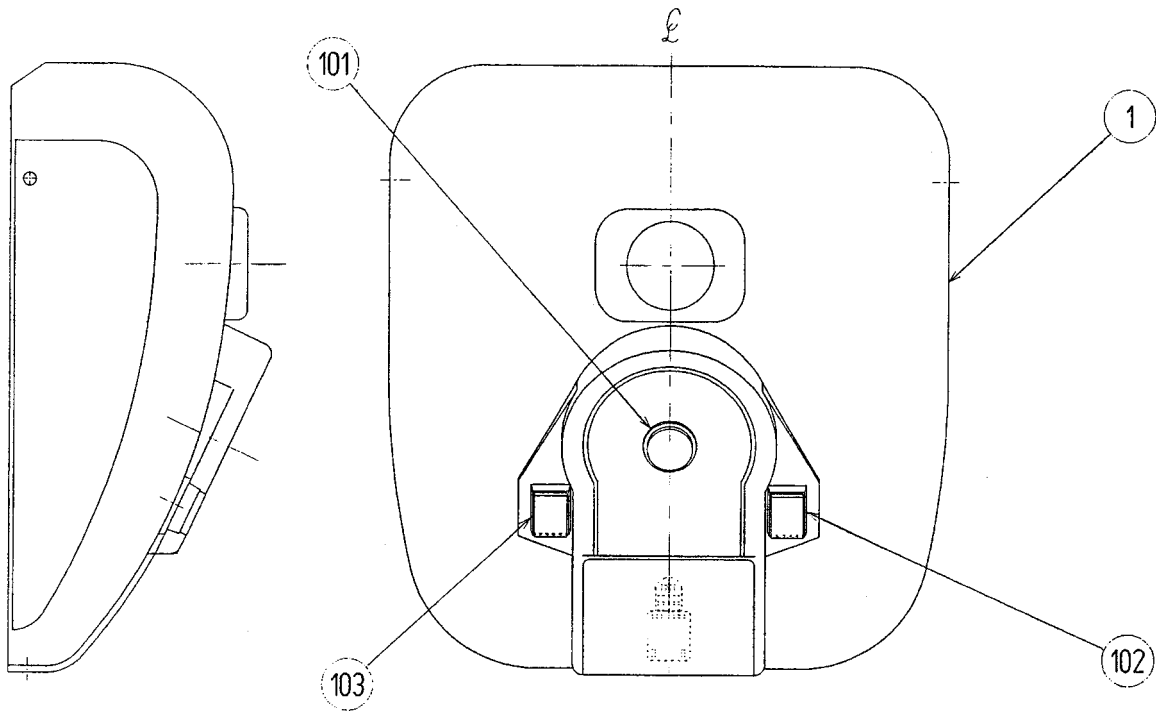

ITEM NO.	PART NO.	DESCRIPTION
1	HLD-1082	FUEL TANK
101	509-0161	SW PB TYPE 1T YEL W LAMP
102	509-5779-RE	SW PB W/LAMP 6V RED
103	509-5779-YE	SW PB W/LAMP 6V YELLOW

ASSY FL (HLD-1130)

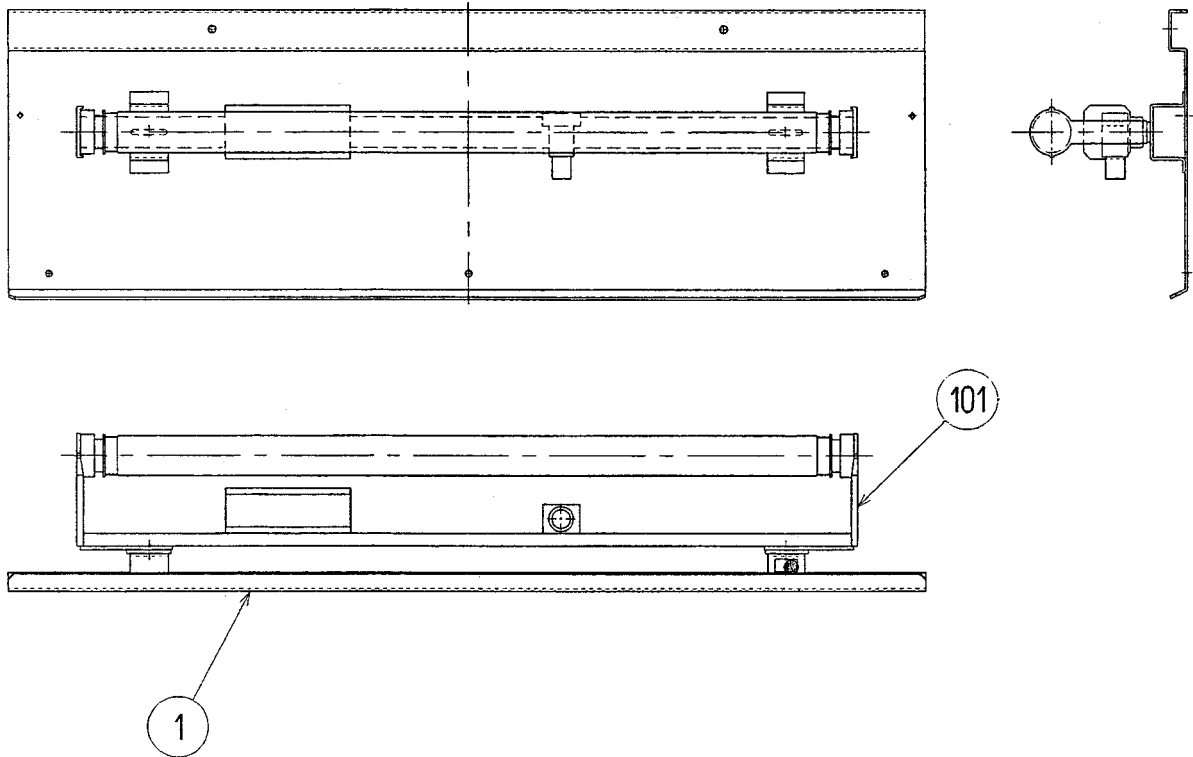

ITEM NO.	PART NO.	DESCRIPTION
1	HLD-1131	FL BASE
101	390-5538-20SD	ASSY FL20W SD W/CONN HIGH L

SW UNIT (HLD-1090)

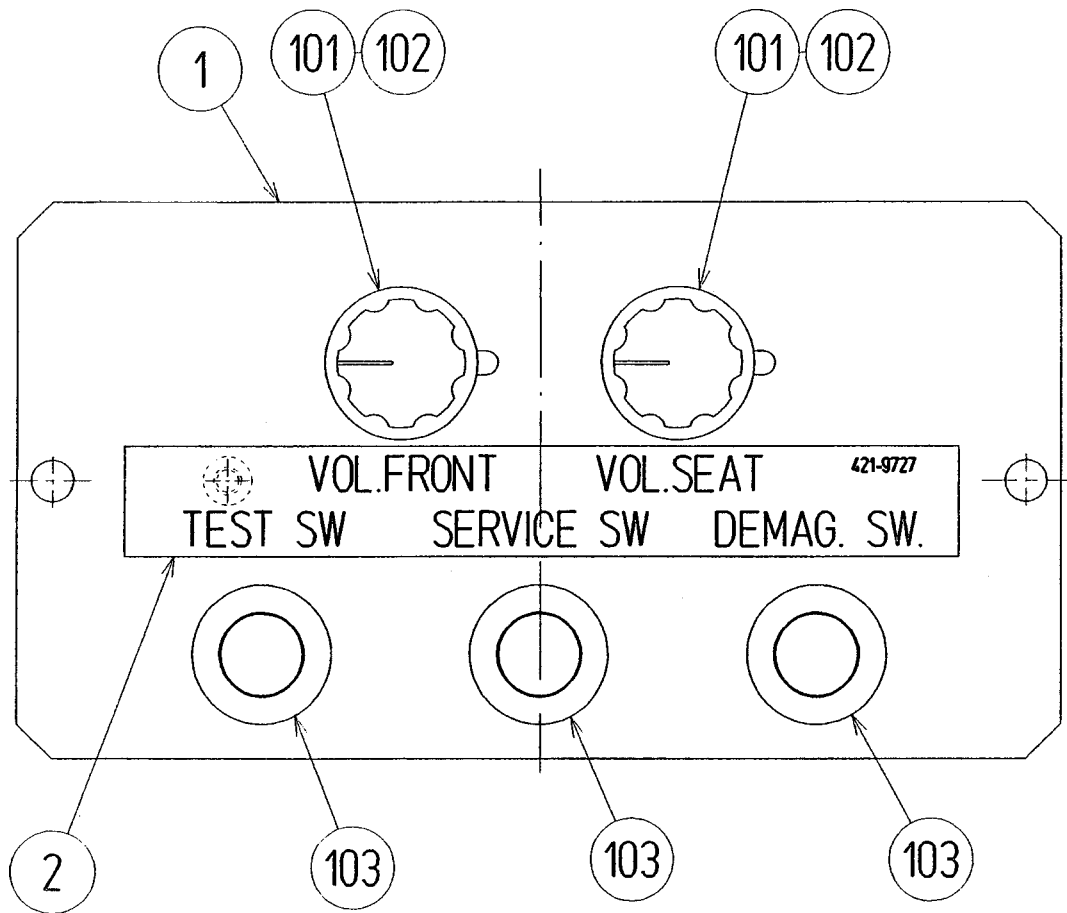

ITEM NO.	PART NO.	DESCRIPTION
1	HLD-1091	SW PLATE
101	220-5179	VOL CONT B-5K OHM
102	601-0042	KNOB 22M
103	509-5028	SW PB 1M

AC UNIT (HLD-1095)

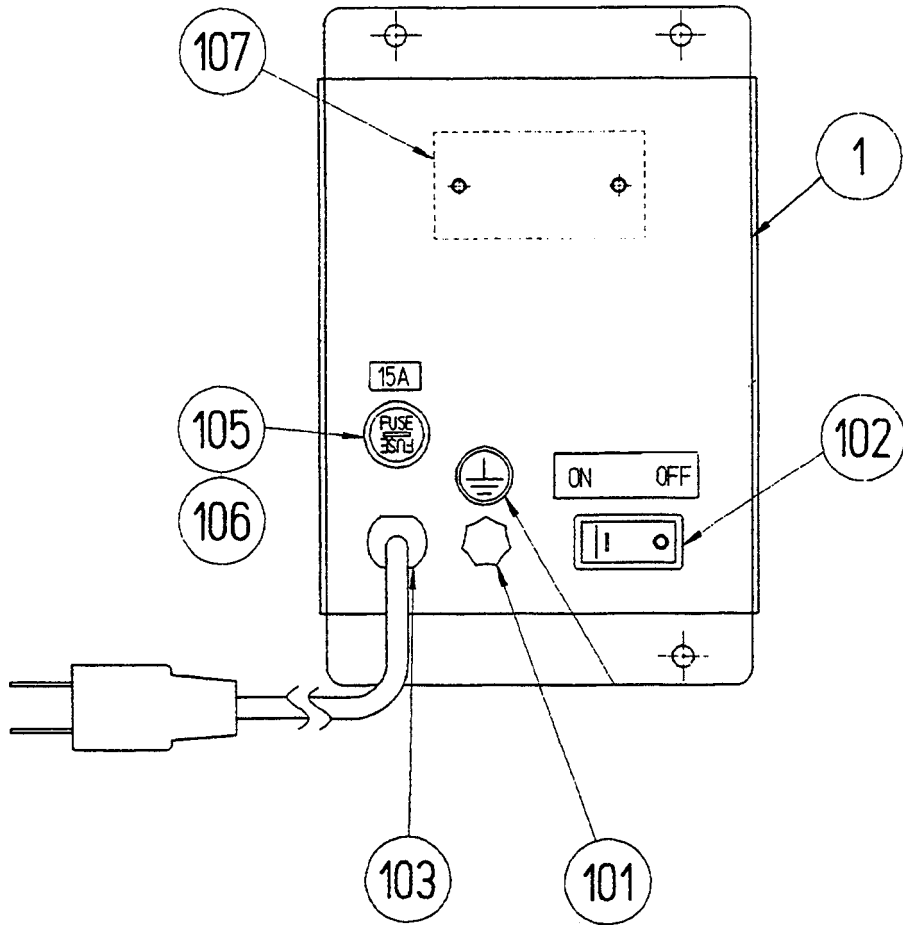

ITEM NO.	PART NO.	DESCRIPTION
1	DYN-1081	AC BRACKET
101	280-0417	TERMINAL BINDING POST BLACK
102	509-5453-H-B	SW ROCKER J8 H-B
103	280-5134-6N4	BUSHING STRAIN RELIEF
105	514-5030-91	FUSE HOLDER
106	LOCAL PURCHASE	FUSE 5A SLO
107	117-5225	TERMINAL PLATE 3P 20A



ASSY HANDLE (HLD-2000)

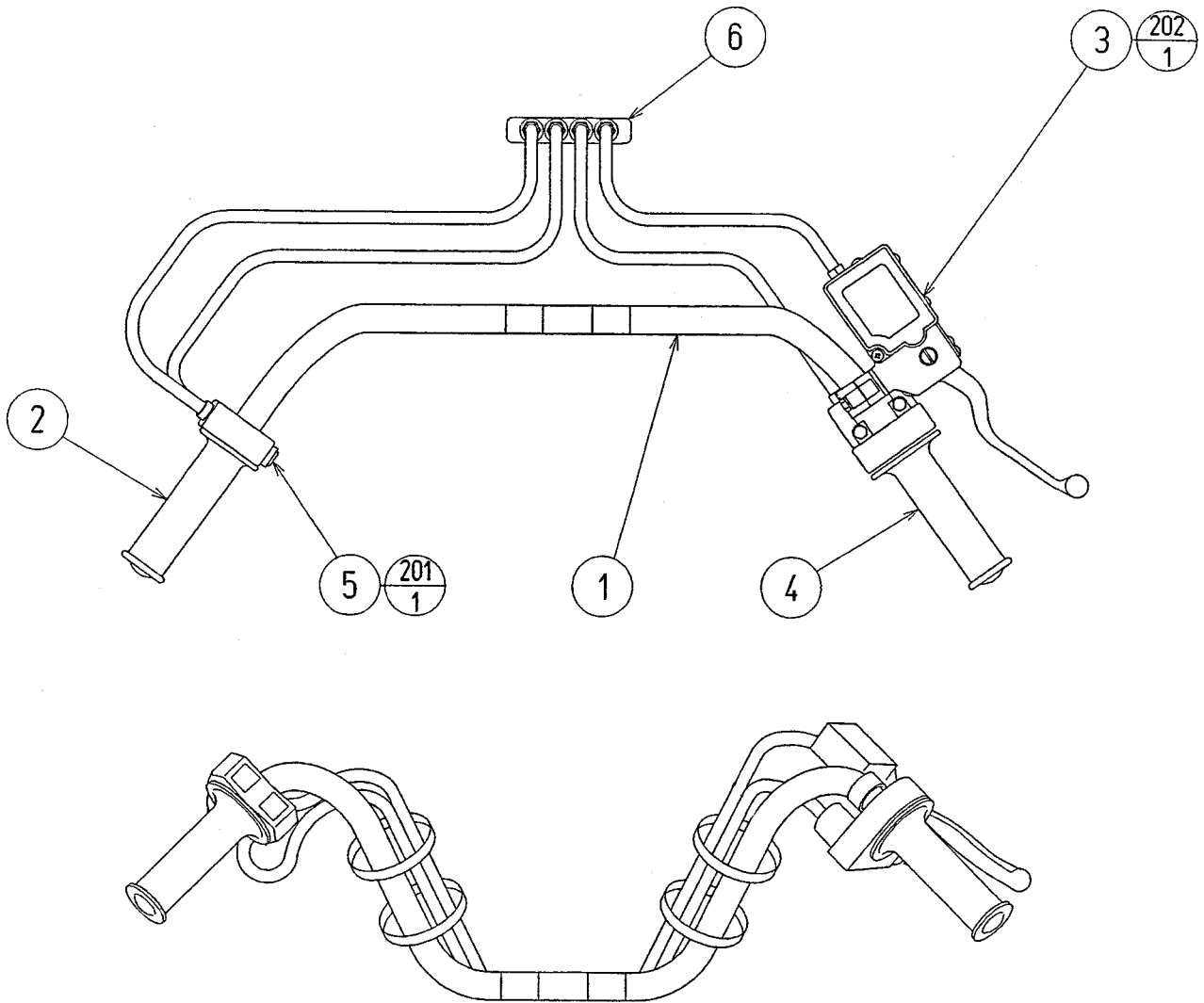

ITEM NO.	PART NO.	DESCRIPTION
1	HLD-2001	HANDLE BAR
2	HLD-2002	GRIP LEFT
3	HLD-2500	ASSY BRAKE MECHA
4	HLD-2600	ASSY THROTTLE
5	HLD-2700	ASSY SHIFT SWITCH
6	HLD-2003	PLATE PROTECT TUBE

ASSY BRAKE MECHA (HLD-2500)

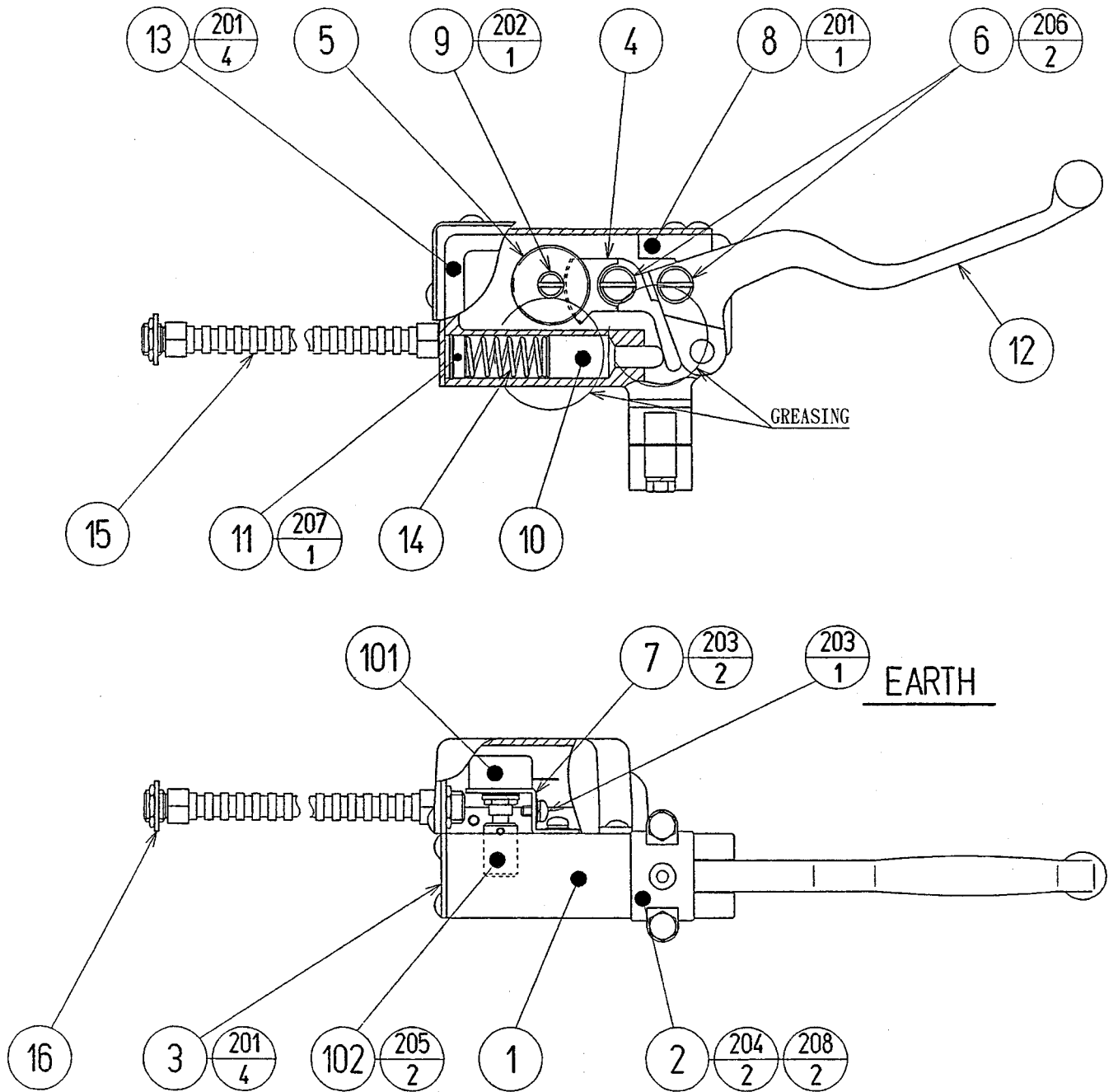

ASSY BRAKE MECHA (HLD-2500)

ITEM NO.	PART NO.	DESCRIPTION
1	HLD-2501	BRAKE MASTER CASE
2	HLD-2502	MASTER CASE HOLDER
3	HLD-2503	MASTER CASE COVER
4	HLD-2504	BRAKE GEAR
5	HLD-2505	IDOL GEAR
6	HLD-2506	PIVOT SHAFT
7	HLD-2507	VR BRKT
8	HLD-2508	LEVER STOPPER
9	HLD-2509	IDOL GEAR SHAFT
10	HLD-2510	MASTER PISTON
11	HLD-2511	END CAP
12	HLD-2512	BRAKE LEVER
13	HLD-2513	VR COVER
14	HLD-2514	RETURN SPRING
15	601-10023	PROTECT TUBE
16	HLD-2004	TUBE WSHR
101	220-5484	VOL CONT B-5K OHM
102	601-7944	GEAR 15
201	000-T00408-0B	M SCR TH BLK M4X8
202	050-C00400-3B	CAP NUT TYPE 3 BLK M4
203	000-P00408-W	M SCR PH W/FS M4X8
204	030—000620-SB	HEX BLT W/S BLK M6X20
205	028-A00306-P	SET SCR HEX SKT CUP P M3X6
206	FAS-500015	CAP NUT BLK M6
207	065-S016H0-Z	STP RING BLK OZ M16
208	065-F00600-0B	FLT WSHR BLK M6

ASSY THROTTLE (HLD-2600)

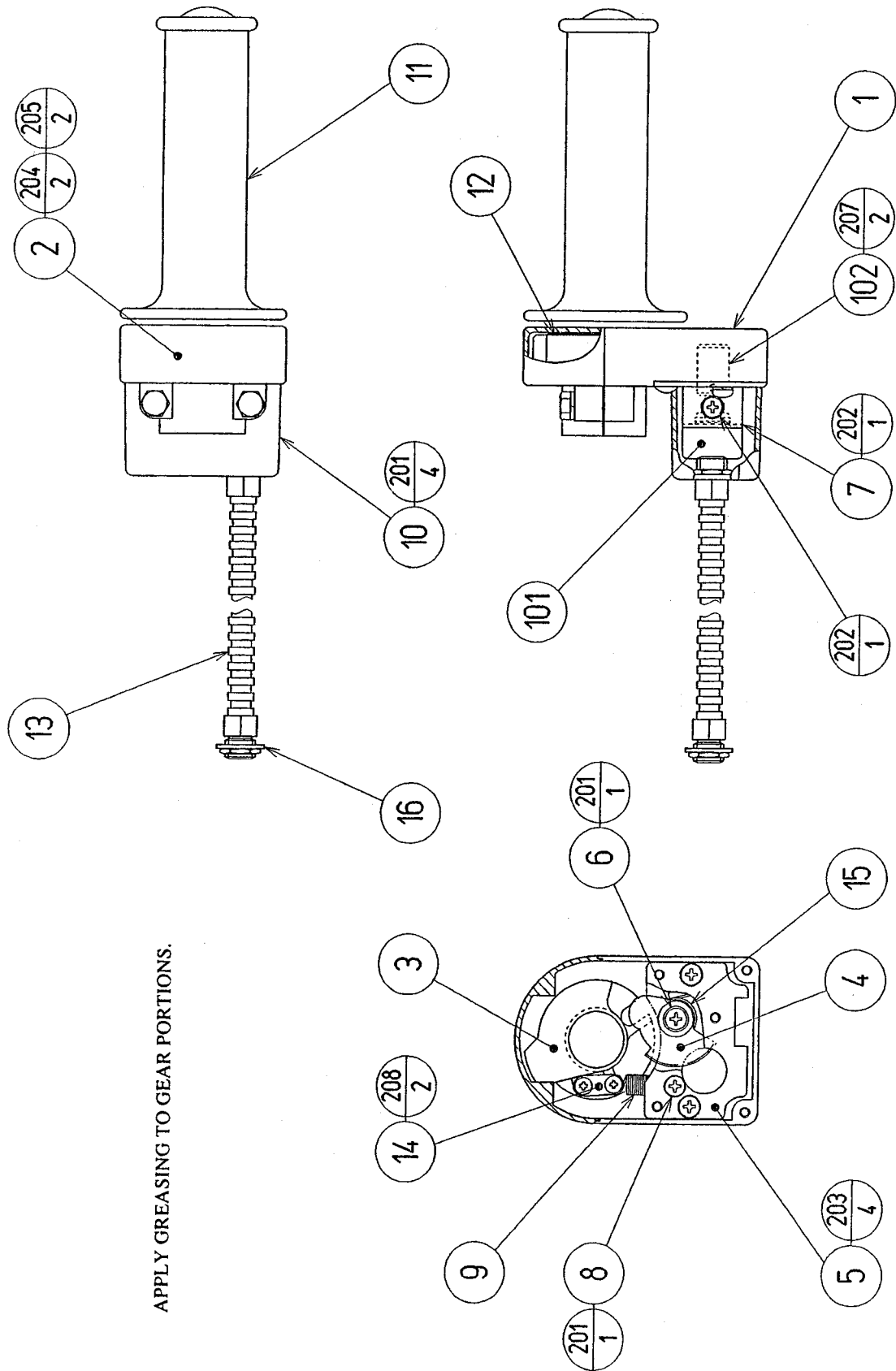

APPLY GREASING TO GEAR PORTIONS.

ASSY THROTTLE (HLD-2600)

ITEM NO.	PART NO.	DESCRIPTION
1	HLD-2601	THROTTLE CASE LOWER
2	HLD-2602	THROTTLE CASE UPPER
3	HLD-2603	INNER GRIP
4	HLD-2604	ACCEL GEAR
5	HLD-2605	BASE PLATE
6	HLD-2606	ACCEL GEAR SHAFT
7	HLD-2607	ACCEL VR BRKT
8	HLD-2608	SPRING HOOK
9	HLD-2609	RETURN SPRING
10	HLD-2610	VR COVER
11	HLD-2611	ACCEL GRIP
12	HLD-2612	SLIDE PLATE
13	601-10023	PROTECT TUBE
14	HLD-2613	SPRING STOPPER
15	HLD-2614	GEAR SPRING
16	HLD-2004	TUBE WSHR
101	220-5484	VOL CONT B-5K OHM
102	601-7944	GEAR 15
201	000-T00408-0B	M SCR TH BLK M4X8
202	000-P00408-W	M SCR PH W/FS M4X8
203	000-F00408	M SCR FH M4X8
204	030-000625-SB	HEX BLT
205	060-F00600-0B	FLT WSHR BLK M6
207	028-A00306-P	SET SCR HEX SKT CUP P M3X6
208	012-P00306	TAP SCR #2 PH 3X6

ASSY SHIFT SWITCH (HLD-2700)

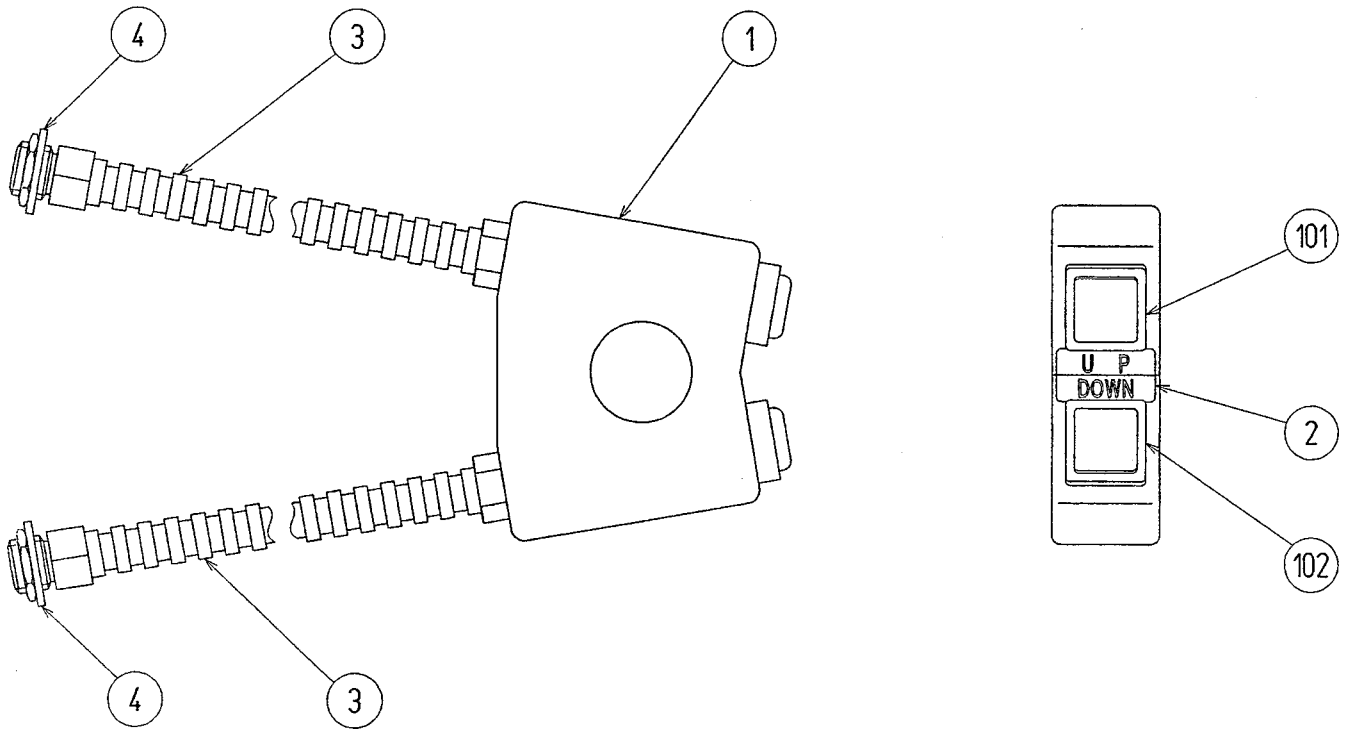

ITEM NO.	PART NO.	DESCRIPTION
1	HLD-2701	SWITCH CASE
2	421-7752	STICKER UP DOWN
3	601-10024-01	PROTECT TUBE EX S
4	HLD-2004	TUBE WSHR
101	509-5003	SW PB TYPE 1T GREEN 14.2
102	509-5003-03	PB SW RED

ASSY CENTERING MECHA (MJT-3650)

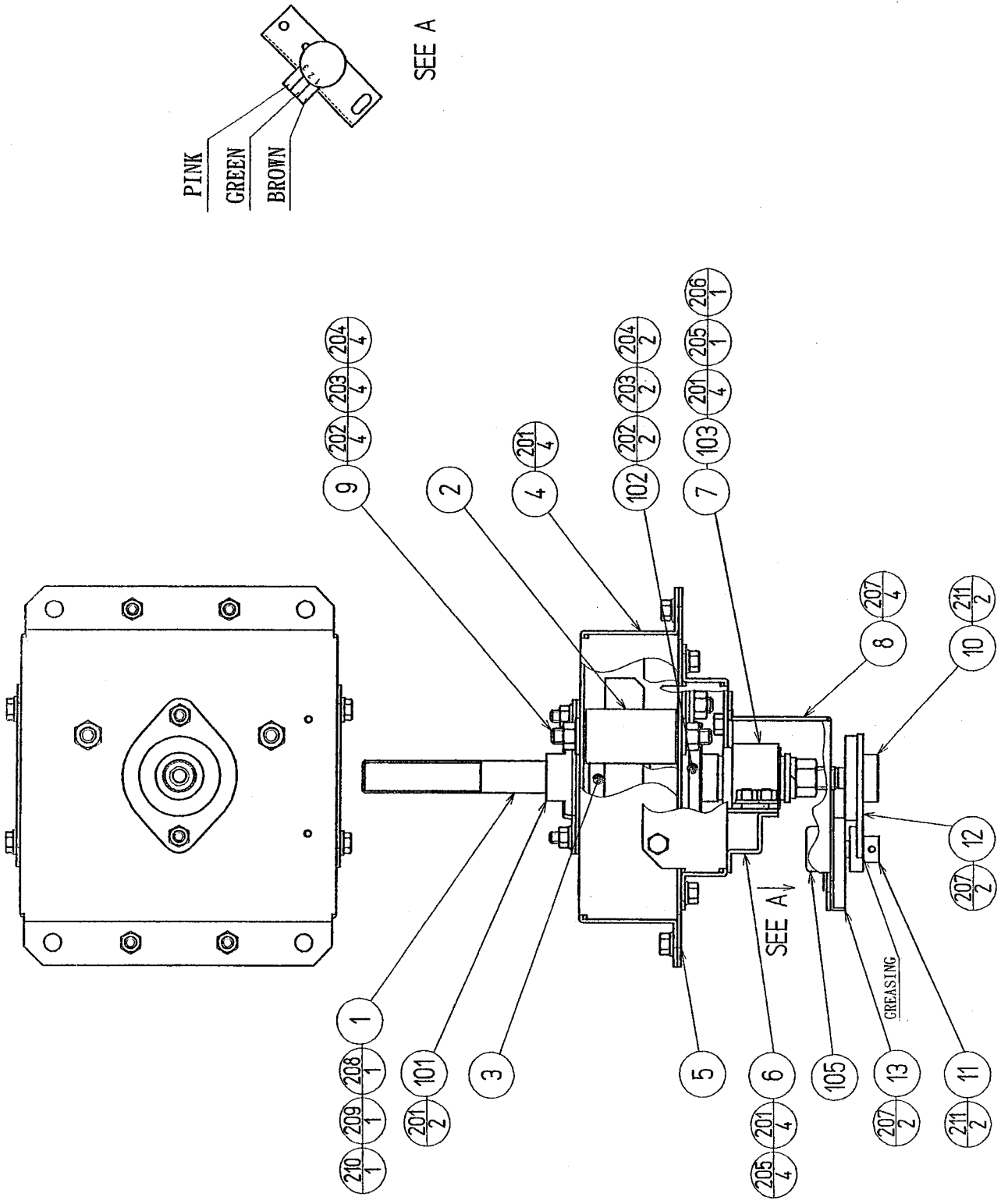

ASSY CENTERING MECHA (MJT-3650)

ITEM NO.	PART NO.	DESCRIPTION
1	MJT-3651	MAIN SHAFT
2	MJT-3652	STOPPER
3	MJT-3653	COLLAR B
4	MJT-3654	MACHA CASE A
5	MJT-3655	MECHA CASE B
6	MJT-3656	LOSTA HOLDER
7	MJT-3657	HOLDER
8	MJT-3658	VR HOLDER
9	MJT-3659	SHAFT
10	TTR-2010	GEAR HOLDER 110
11	601-6555	GEAR Z=30 M=0.75
12	601-6450	GEAR 110
13	RDY-2106	VR BRACKET
101	100-5096	BEARING 17
102	100-5043	BEARING 25 FYH SBP FL 205
103	601-8847	LOSTA DR-S-18X30
105	220-5484	VOL CONT B-5K OHM
201	050-F00600	FLG NUT M6
202	060-F00800	FLT WSHR M8
203	060-S00800	SPR WSHR M8
204	050-H00800	HEX NUT M8
205	030-000612-S	HEX BLT W/S M6X12
206	060-F00600	FLT WSHR M6
207	000-P00408-W	M SCR PH W/FS M4X12
208	060-F01200	FLT WSHR M12
209	060-S01200	SPR WSHR M12
210	050-H01200	HEX NUT M12
211	028-A00410-P	SET SCR HEX SKT CUP P M4X10



ASSY FOOT BRAKE MECHA (HLD-2800)

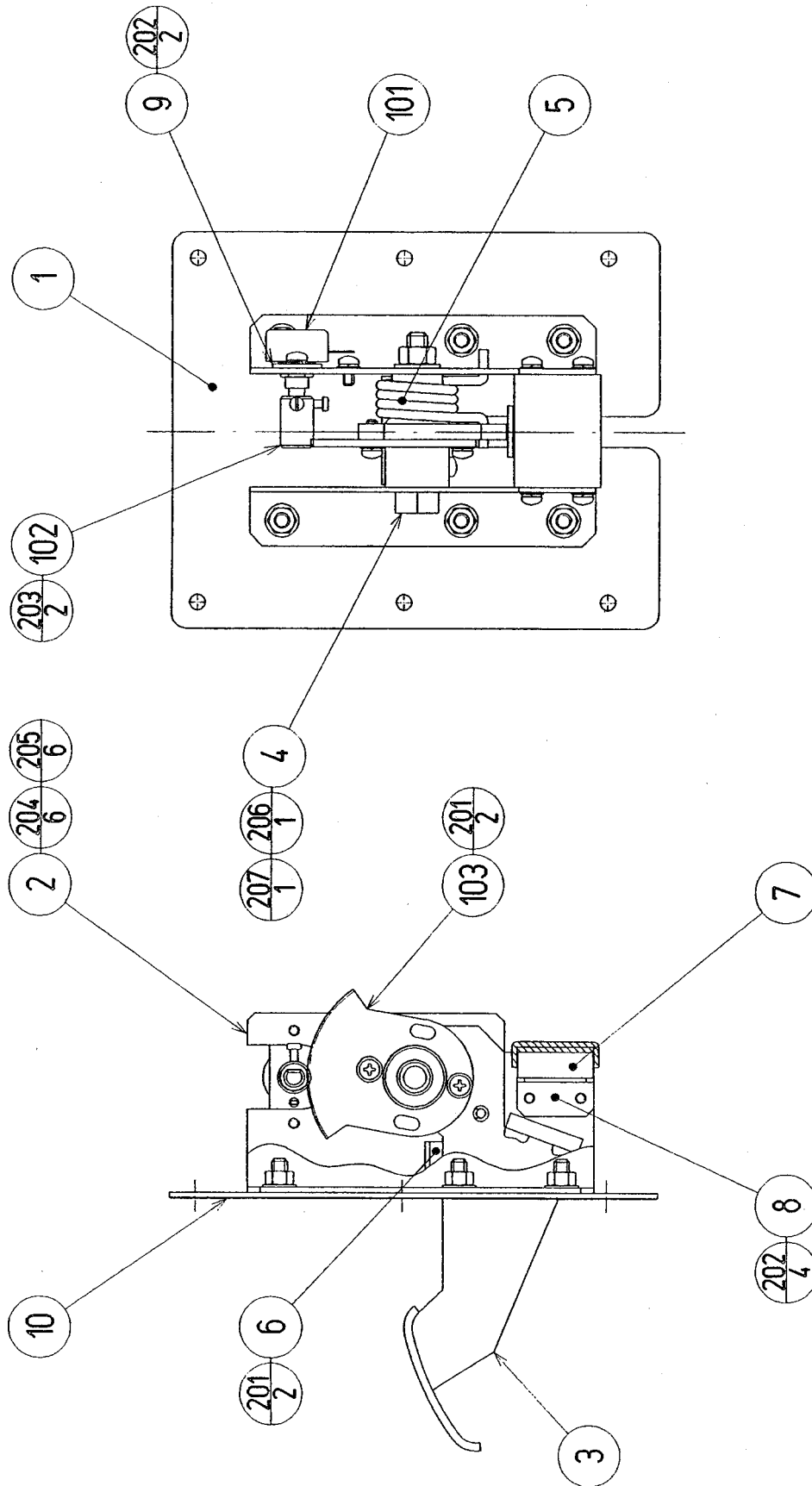

ASSY FOOT BRAKE MECHA (HLD-2800)

ITEM NO.	PART NO.	DESCRIPTION
1	HLD-2801	PEDAL PLATE
2	HLD-2802	PEDAL BRKT
3	HLD-2803	BRAKE PEDAL
4	HLD-2805	PEDAL SHAFT
5	HLD-2805	TORSION SPRING
6	HLD-2806	STOPPER RUBBER UPPER
7	HLD-2807	STOPPER RUBBER LOWER
8	HLD-2808	RUBBER HOLDER
9	POW-2613	VR PLATE
10	HLD-2809	PROTECT PLATE
101	220-5484	VOL CONT B-5K OHM
102	601-7944	GEAR 15
103	601-6450	GEAR 110
201	000-P00412-W	M SCR PH W/FS M4X12
202	000-P00408-W	M SCR PH W/FS M4X8
203	028-C00308-P	SET SCT CH CUP P M3X8
204	050-U00600	U NUT M6
205	060-F00600	FLT WSHR M6
206	050-U00800	U NUT M8
207	060-F00800	FLT WSHR M8

ASSY MAIN BD STD (HLD-4700)

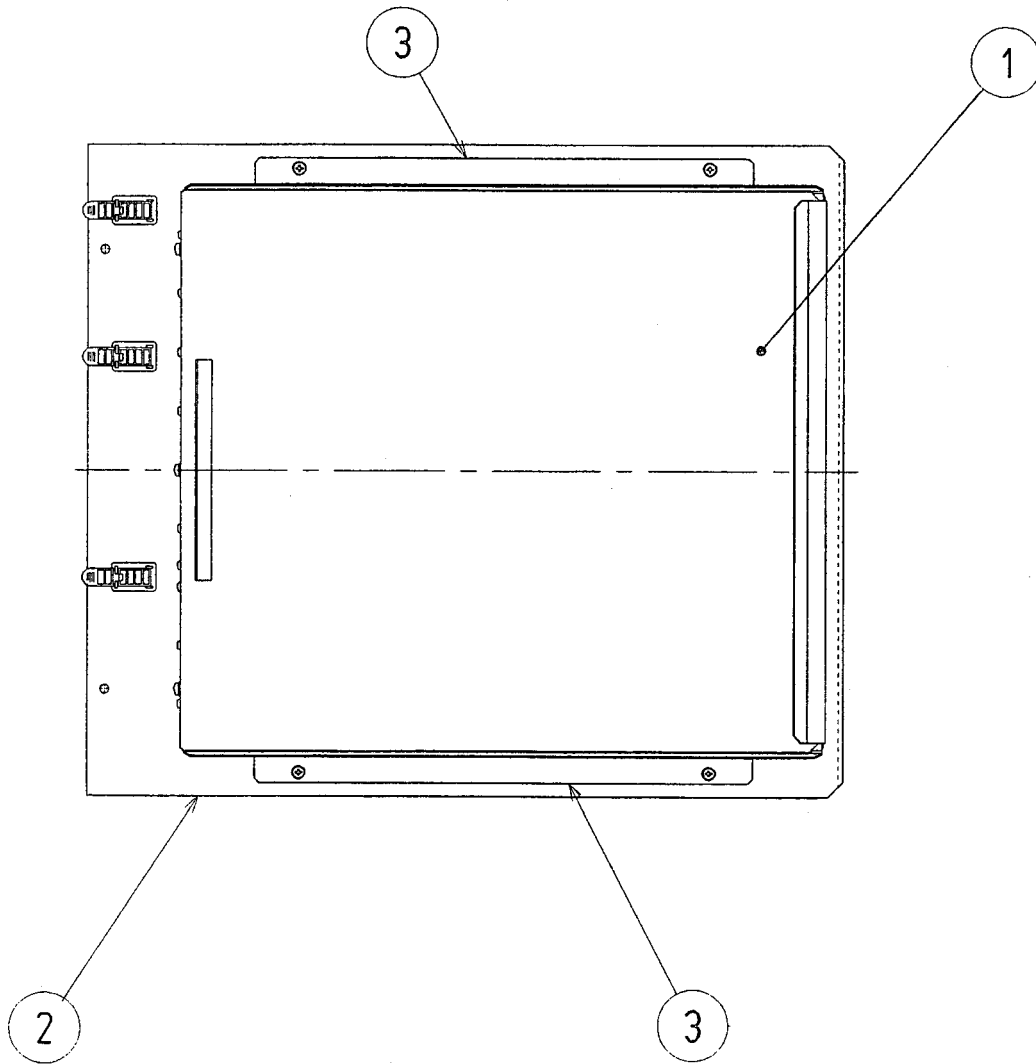

ITEM NO.	PART NO.	DESCRIPTION
1	HLD-4400	ASSY SHIELD CASE
2	HLD-4701	WOODEN BASE MAIN BD
3	105-5241	SHIELD CASE BRKT

ASSY SHIELD CASE (HLD-4400)

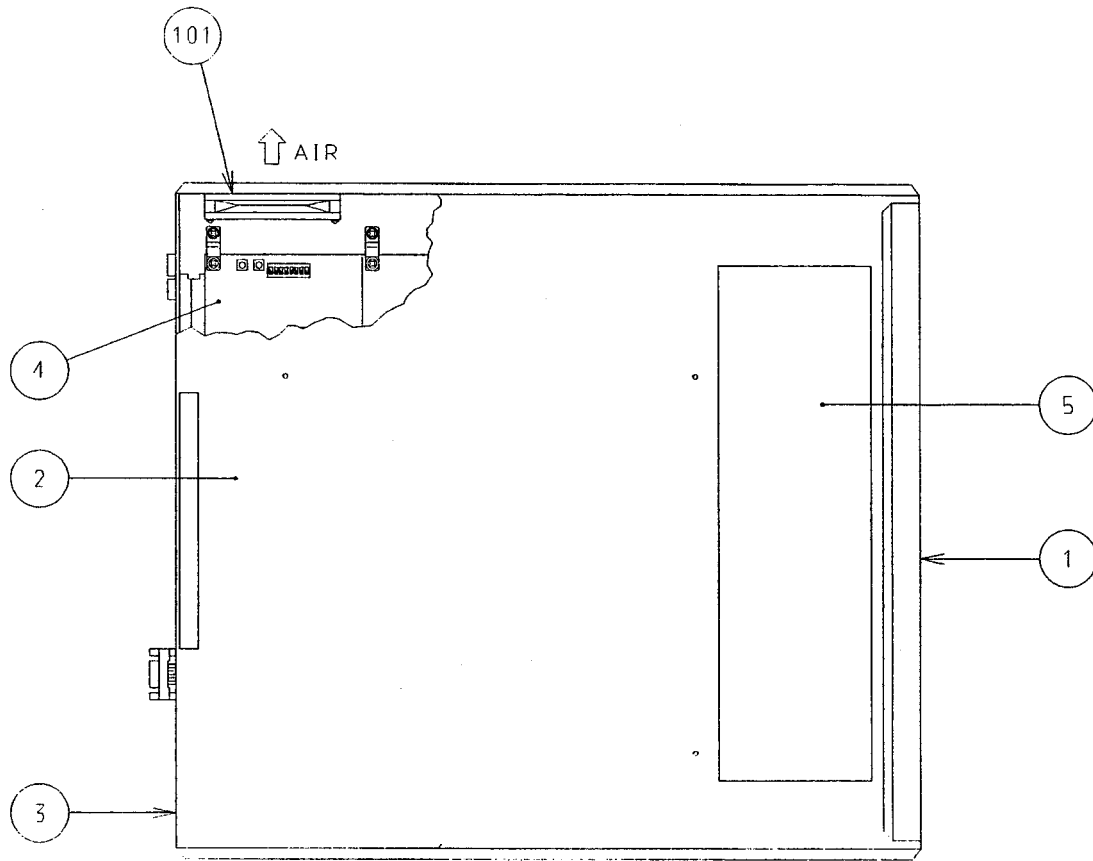

ITEM NO.	PART NO.	DESCRIPTION
1	105-5240Y	SHIELD CASE MODEL 3
2	105-5242X	SHILED CASE LID MODEL 3
3	839-0932	FILTER BD MODEL 3 SPG
4	833-13325	GAME BD HARLEY-DAVIDSON
101	260-0064	FAN MOTOR DC 12V

ASSY ELEC (HLD-4500)

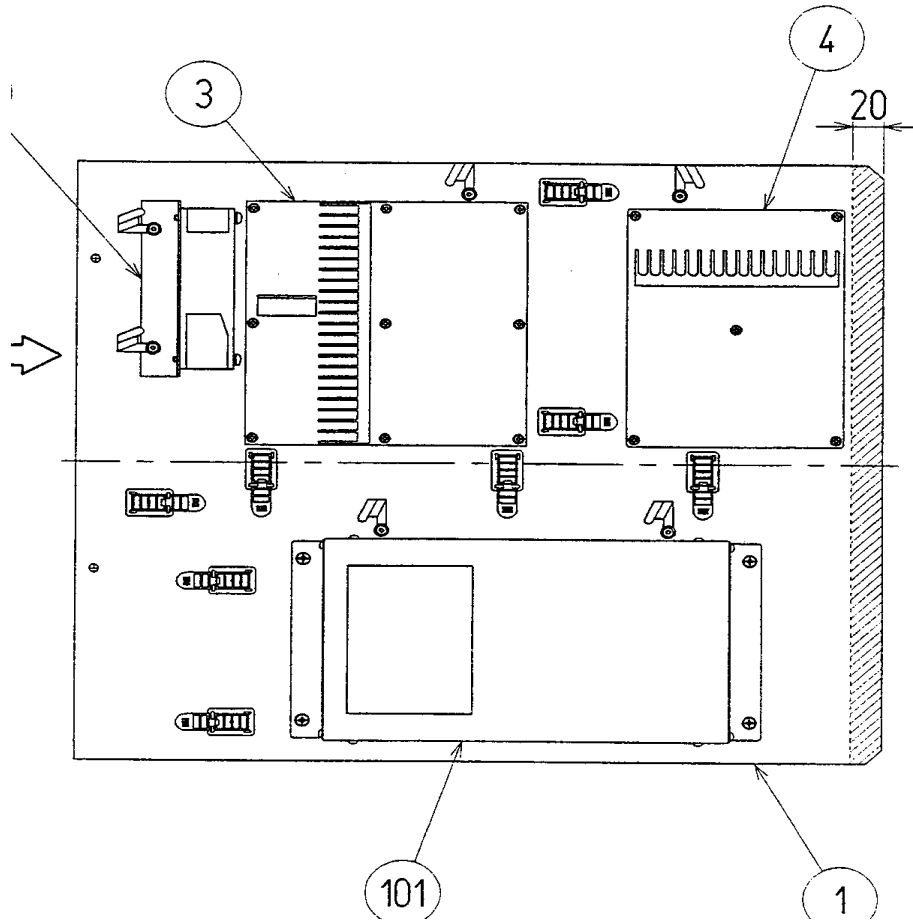

ITEM NO.	PART NO.	DESCRIPTION
1	HLD-4501	WOODEN BASE ELEC
2	BY-4102	FAN MOTOR BRACKET
3	838-13142	BASS AMP 50WX2
4	838-11650-36	EQ. PWR AMP HLD STD
101	400-5330-02-91	SW REGU FOR MODEL 3
102	260-0011-02	AXIAL FLOW FAN AC100V 50-60HZ
103	280-0419	HARNES LUG

ASSY POWER SUPPLY (HLD-4600)

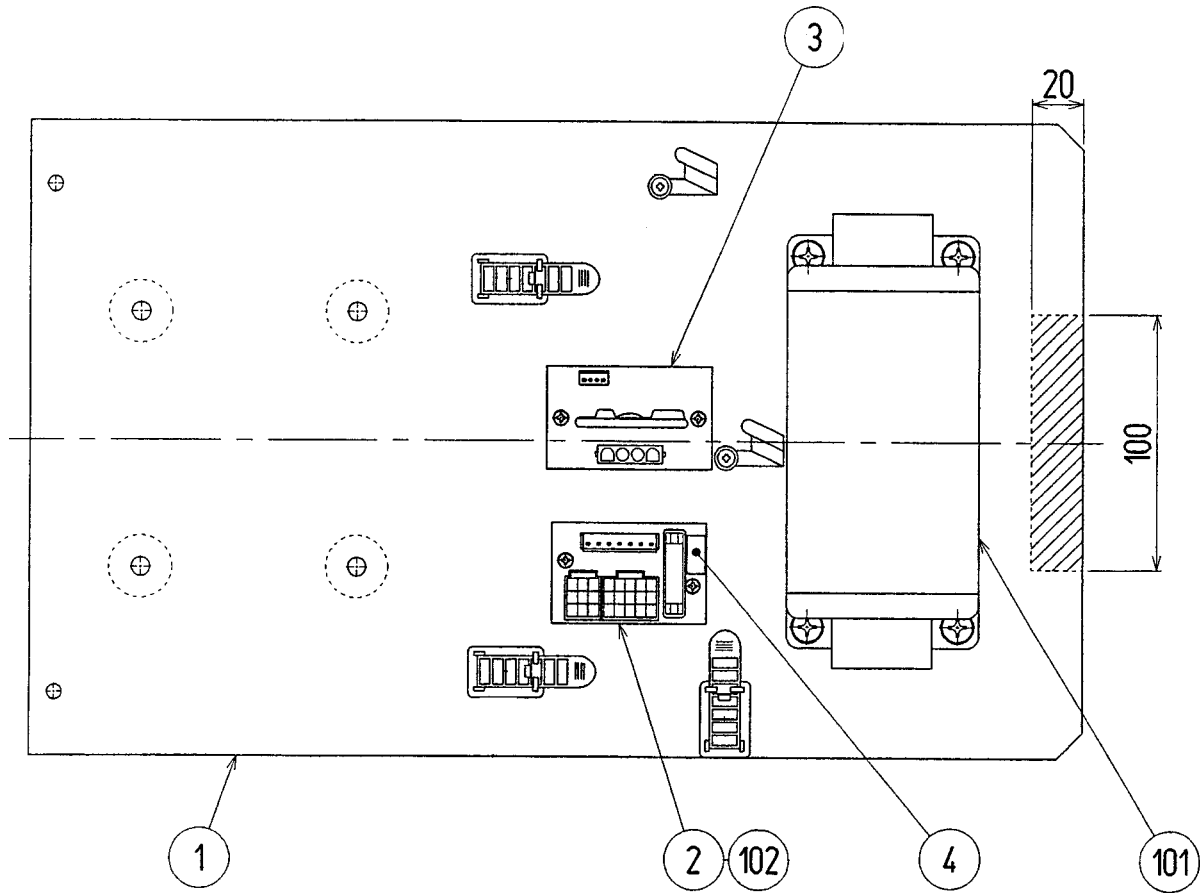

ITEM NO.	PART NO.	DESCRIPTION
1	HLD-4601	WOODEN BASE PWR SUPPLY
2	838-11856-01	CONNECT BD W/FUSE & COVER
3	839-1011-01	SSR 1EA BD BR
101	560-5380	AUDIO XFMR 12.8V 6A 23V 9.6AX2
102	LOCAL PURCHASE	FUSE 5A SLO

ASSY SEAT CABI (HLD-3050)

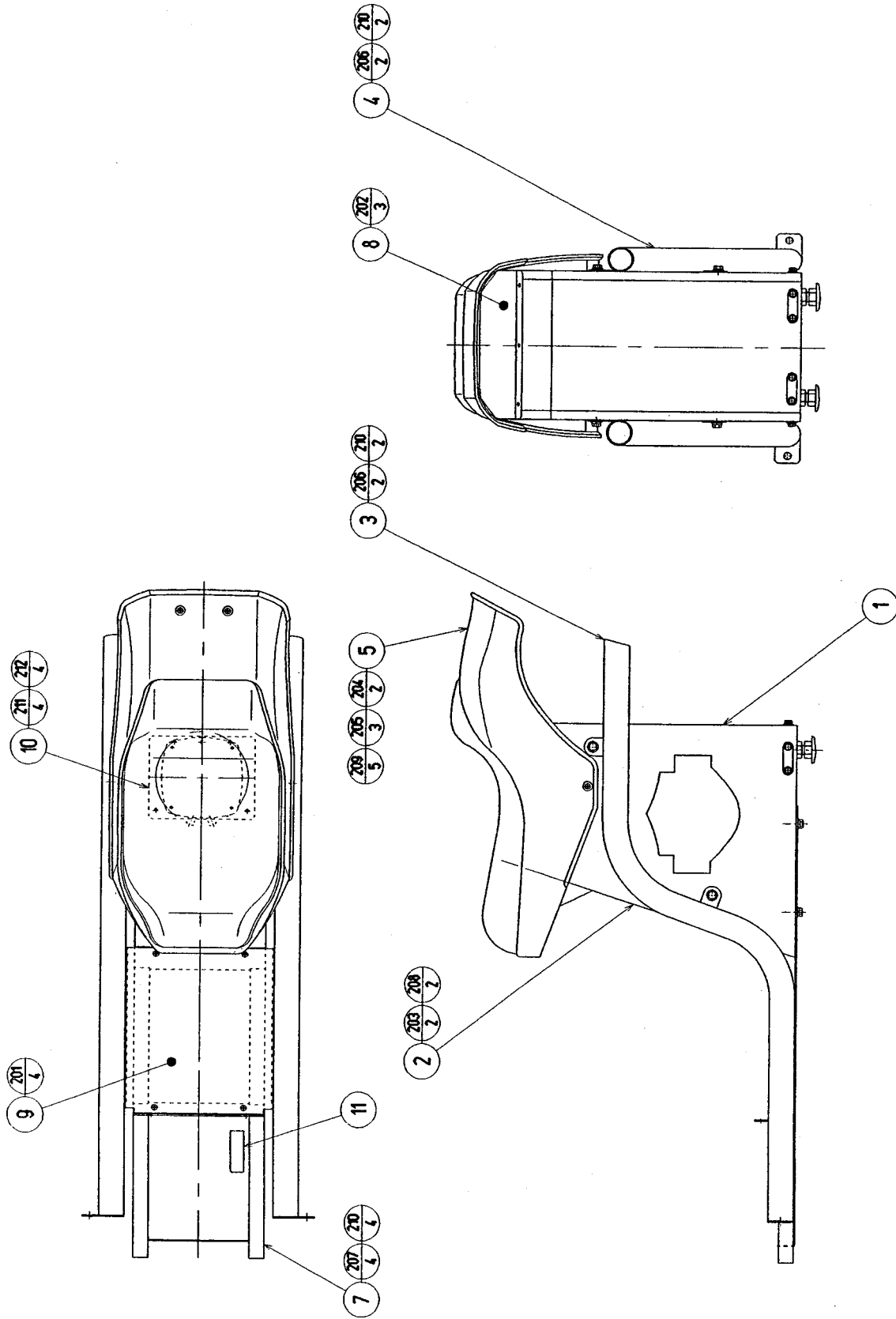

ASSY SEAT CABI (HLD-3050)

ITEM NO.	PART NO.	DESCRIPTION
1	HLD-3051	SEAT CABINET
2	HLD-3052	MAINTENACE LID
3	HLD-3053	EX PIPE L
4	HLD-3054	EX PIPE R
5	HLD-3055	REAR FENDER
7	HLD-3057	JOINT FRAME
8	HLD-3058	FENDER STAY
9	HLD-3059	JOINT LID
10	HLD-3600	ASSY VIBRATOR
201	000-T00408-0B	M SCR TH BLK M4X8
202	000-T00416-0B	M SCR TH BLK M4X16
203	000-T00425-0B	M SCR TH BLK M4X25
204	000-T00412-0C	M SCR TH CRM M4X12
205	000-T00425-0C	M SCR TH CRM M4X25
206	030-000820-SB	HEX BLT W/S BLK M8X20
207	030-000860-SB	HEX BLT W/S BLK M8X60
208	068-441616-0B	FLT WSHR BLK 4.4-16X1.6
209	068-441616-0C	FLT WSHR CRM 4.4-16X1.6
210	060-F00800-0B	FLT WSHR BLK M8
211	050-U00600	U NUT M6
212	068-652016	FLT WSHR 6.5-20X1.6



ASSY VIBRATOR (HLD-3600)

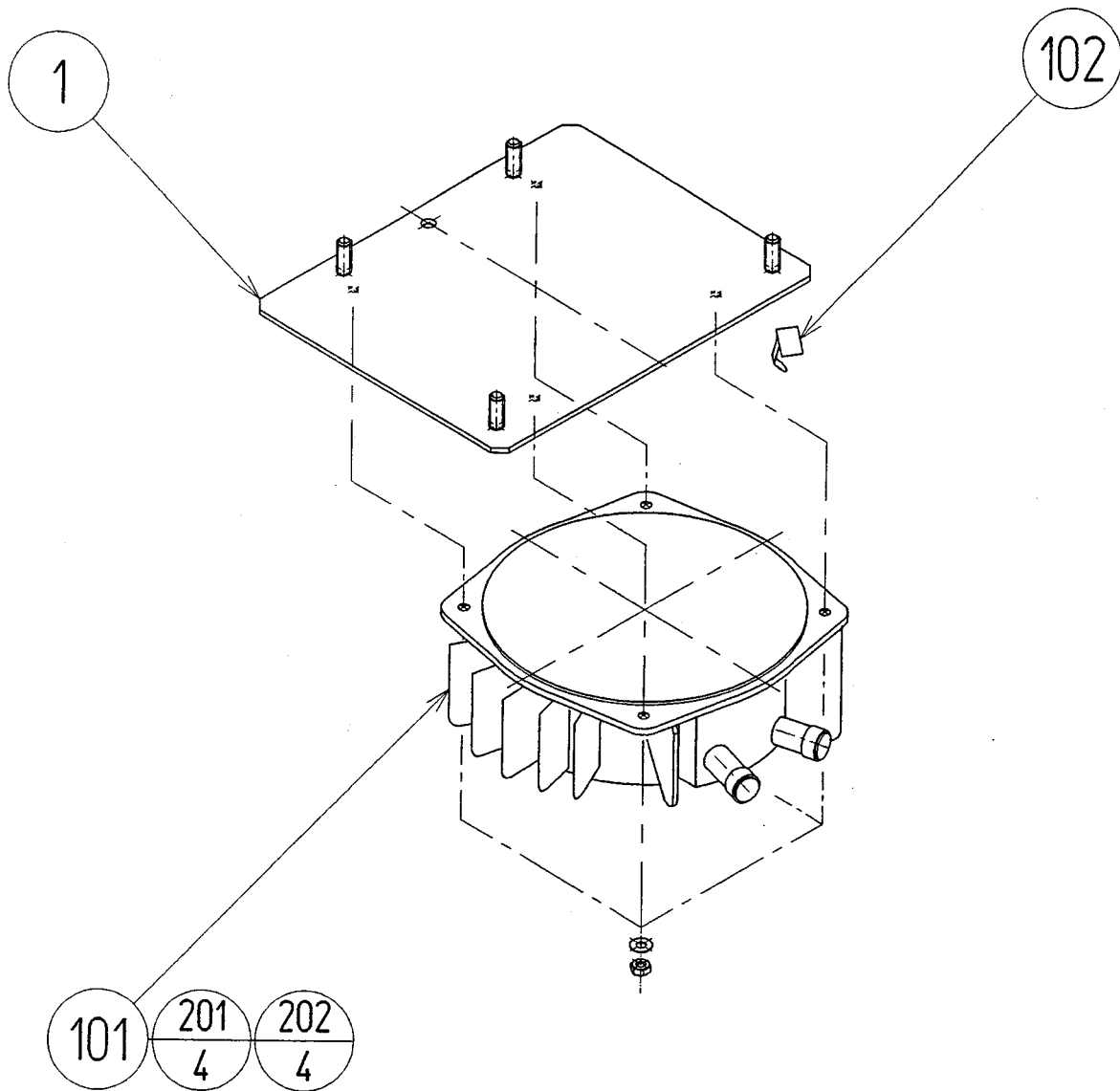

ITEM NO.	PART NO.	DESCRIPTION
1	HLD-3601	MOUNT PLATE
101	130-5172	BASS SHAKER
201	050-U00400	U NUT M4
202	060-F00400	FLT WSHR M4

# Come see Sega GameWorks Service Department's Homepage

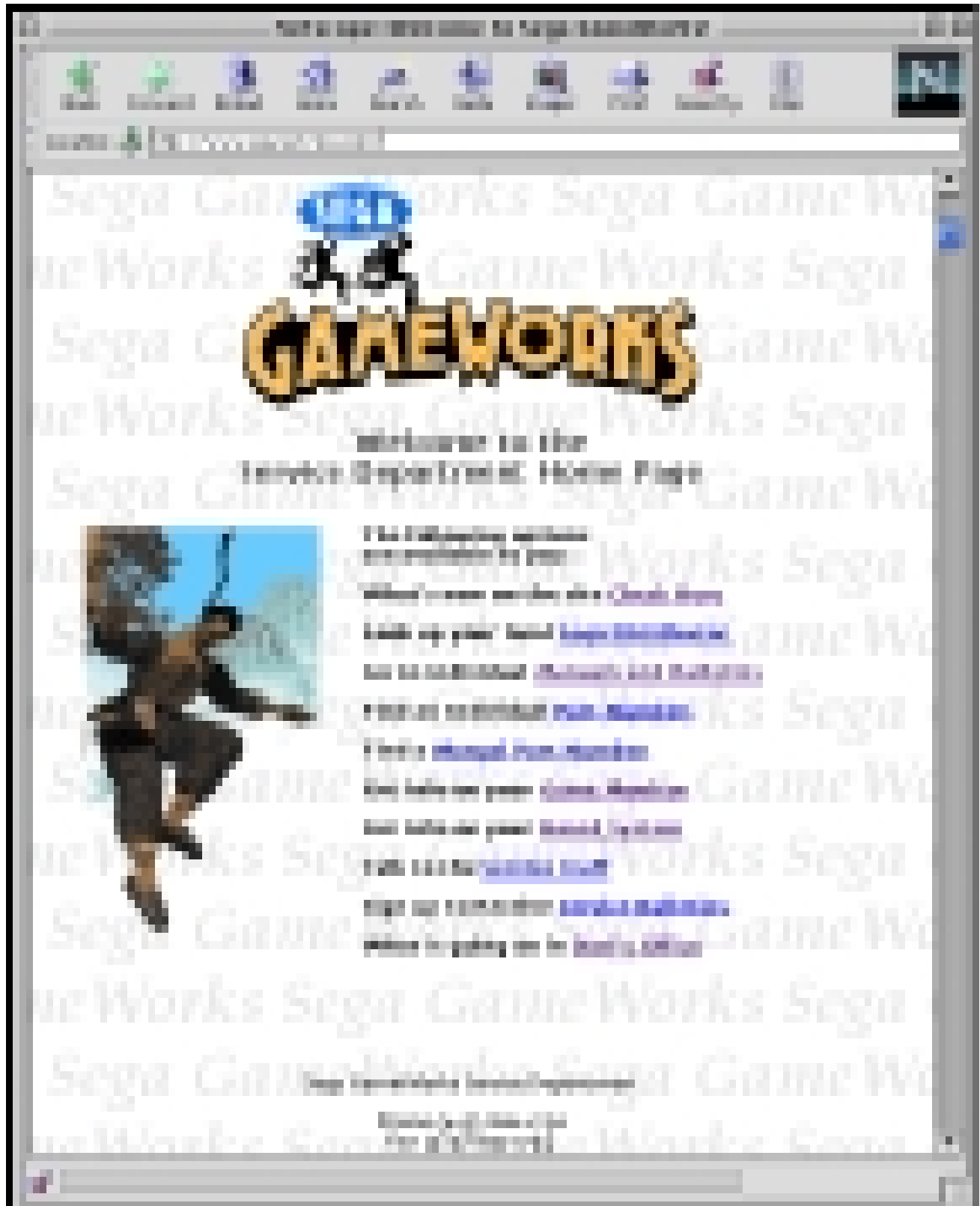



**SEGA ENTERPRISES, INC. (USA)**

45133 Industrial Drive  
Fremont, CA 94538  
415/650-802-1750 phone  
415/650-802-1754 fax