



BOOT CAMP

BOOT CAMP

BOOT CAMP

BOOT CAMP

BOOT CAMP is a registered trademark of Konami Inc. • 1987 Konami Inc.

 K^{ONAMI} is a trademark of Konami Industry Co., Ltd.

BOOT CAMP: AC FLOW CHART

- 1. GREEN/YELLOW
- 2. BLACK
- 3. RED
- 4. BLUE
- 5. BROWN
- 6. RED/BLACK
- 7. BLACK/WHITE
- 8. WHITE
- 9. GREEN
- 10. VIOLET
- 11. ORANGE

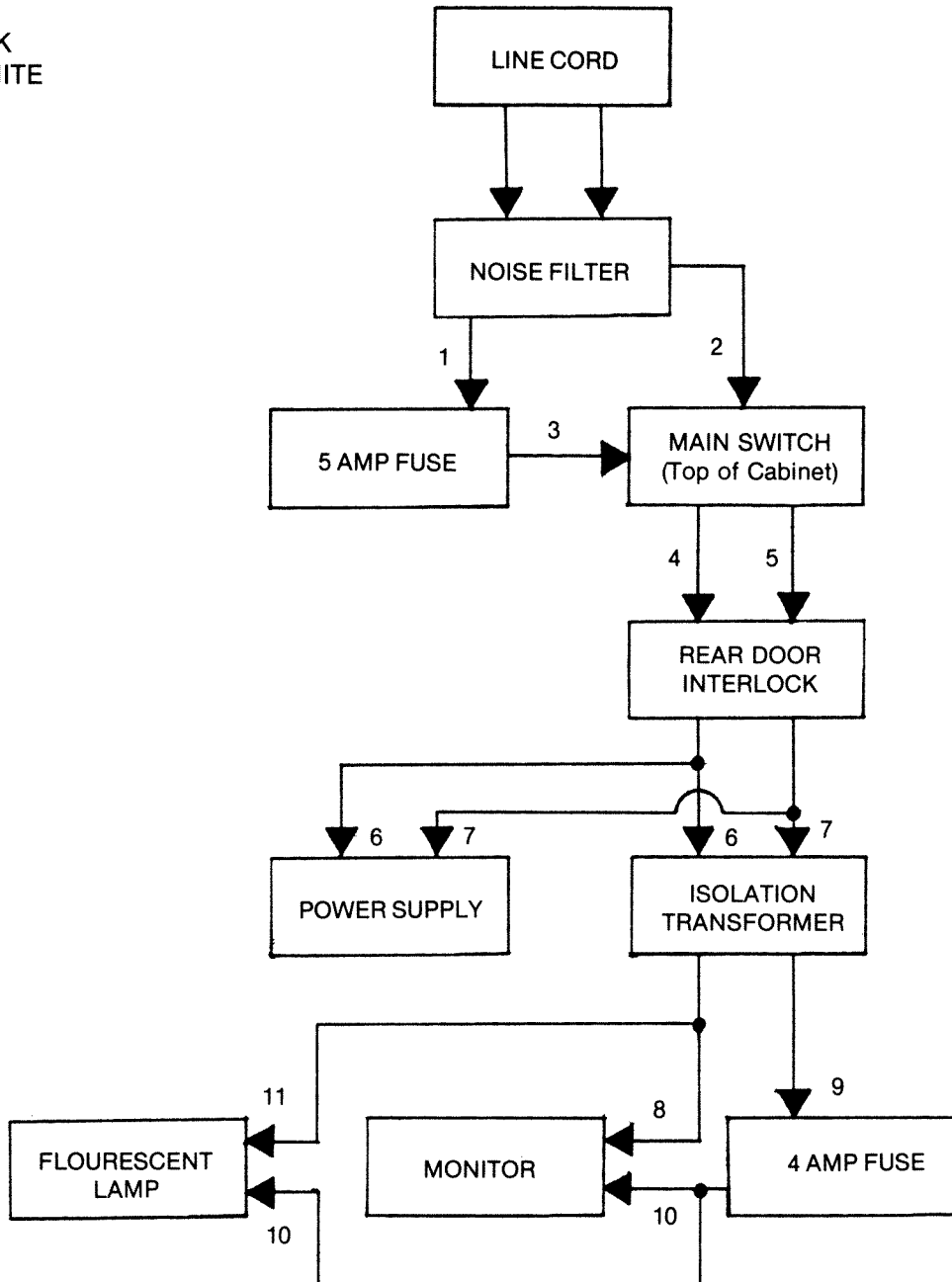

BOOT CAMP: WIRING HARNESS

WIRE COLOR KEY:		Solder Side ←		→ Parts Side	
BLACK	GND	A	1	GND	BLACK
BLACK	GND	B	2	GND	BLACK
RED	+ 5V DC	C	3	+ 5V DC	RED
RED	+ 5V DC	D	4	+ 5V DC	RED
		E	5		
ORANGE	+ 12V DC	F	6	+ 12V DC	ORANGE
	*KEY	H	7	*KEY	
BROWN/YELLOW	COIN COUNTER 2	J	8	COIN COUNTER 1	GREEN/GRAY
		K	9		
BROWN/WHITE	SPEAKER	L	10	SPEAKER	YELLOW/BROWN
		M	11		
WHITE/GREEN	VIDEO GREEN	N	12	VIDEO RED	RED/WHITE
WHITE	VIDEO SYNC	P	13	VIDEO BLUE	BLUE/WHITE
		R	14	VIDEO GROUND	BLACK
		S	15		
VIOLET/WHITE	COIN 2	T	16	COIN 1	BLUE/BROWN
RED/GREEN	2P START	U	17	1P START	PINK/YELLOW
		V	18		
		W	19		
		X	20		
		Y	21		
BLACK/YELLOW	2P ATTACK	Z	22	1P ATTACK	PINK/WHITE
ORANGE/GRAY	2P JUMP	a	23	1P JUMP	GREEN/BROWN
		b	24		
		c	25		
		d	26		
BLACK	GND	e	27	GND	BLACK
BLACK	GND	f	28	GND	BLACK

(BASE COLOR/LINE COLOR)

(* FOR TRACK BALL SEE PAGE 4)

DIP SWITCH NO. 1 SETTINGS

1. COIN SWITCH No. 1 SETTINGS

SW	1	2	3	4	COIN	PLAY
•	OFF	OFF	OFF	OFF	1	1
	ON	OFF			1	2
	OFF	ON			1	3
	ON	ON			1	4
	OFF	OFF	ON	OFF	1	5
	ON	OFF			1	6
	OFF	ON			1	7
	ON	ON			2	1
	OFF	OFF	OFF	ON	2	3
	ON	OFF			2	5
	OFF	ON			3	1
	ON	ON			3	2
	OFF	OFF	ON	ON	3	4
	ON	OFF			4	1
	OFF	ON			4	3
	ON	ON			FREEPLAY	

2. COIN SWITCH NO. 2 SETTINGS

SW	5	6	7	8	COIN	PLAY
•	OFF	OFF	OFF	OFF	1	1
	ON	OFF			1	2
	OFF	ON			1	3
	ON	ON			1	4
	OFF	OFF	ON	OFF	1	5
	ON	OFF			1	6
	OFF	ON			1	7
	ON	ON			2	1
	OFF	OFF	OFF	ON	2	3
	ON	OFF			2	5
	OFF	ON			3	1
	ON	ON			3	2
	OFF	OFF	ON	ON	3	4
	ON	OFF			4	1
	OFF	ON			4	3
	ON	ON			VOID	

DIP SWITCH NO. 2 SETTINGS

1. ADJUSTMENT FOR TABLE/UPRIGHT

SW	3	TYPE
•	OFF	TABLE
	ON	UPRIGHT

2. DIFFICULTY OF THE GAME

SW	6	7	DIFFICULTY
•	OFF	OFF	EASY
	ON	OFF	NORMAL
	OFF	ON	DIFFICULT
	ON	ON	VERY DIFFICULT

3. SOUND IN ATTRACTIVE MODE

SW	8	SOUND
•	OFF	OFF
	ON	ON

*SW 1 NOT USED
 SW 2 NOT USED
 SW 4 NOT USED
 SW 5 NOT USED

DIP SWITCH NO. 3 SETTINGS

1. VIDEO SCREEN FLIP

SW	1	MONITOR
•	OFF	NORMAL
	ON	UPSIDE DOWN

2. CHANGE OF MODE

SW	3	MODE
•	OFF	GAME MODE
	ON	TEST MODE

*SW 2 NOT USED
 SW 4 NOT USED

- Shows recommended settings

SELF TEST

Normal: OK will be displayed, and then the game will start.
 Abnormal: BAD will be displayed, and the screen will stop.

MANUAL TEST

- A . How to start.
 Turn on the SW3 of DIP SW3.
- B . Test item.
- (1) Conditioning of pictures contortion.
 - (2) Sound check.
 - (3) Color conditioning.
 - (4) Control check.
 - (5) Coin counter check.
 - (6) DIP SW SET.
- * To change items, PUSH 1P START button.

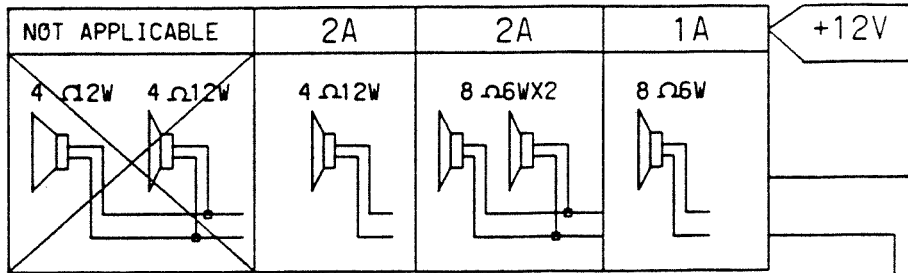

----- NOTE -----

SURGE KILLER DIODE FOR
COIN COUNTER INSTALLED ON PCB

WICO 3 INCH TRACK BALL

2P LEFT/RIGHT

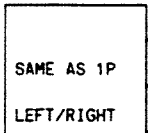

2P UP/DOWN

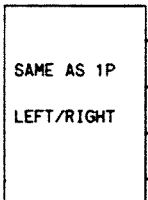

1P UP/DOWN

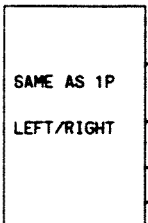

1P LEFT/RIGHT

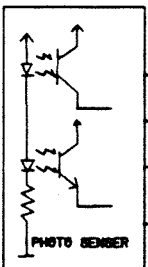

- 10
- 9
- 8
- 7
- 6
- 5
- 4
- 3
- 2
- 1

- GND BLACK
- + 5V RED
- 2P UP/DOWN GREEN
- 2P UP/DOWN YELLOW
- 2P LEFT/RIGHT BLUE
- 2P LEFT/RIGHT VIOLET
- 1P LEFT/RIGHT GREEN
- 1P LEFT/RIGHT YELLOW
- 1P UP/DOWN BLUE
- 1P UP/DOWN VIOLET

JST 10PIN POST W/BASE
B10PS-VH
3.96MM PITCH

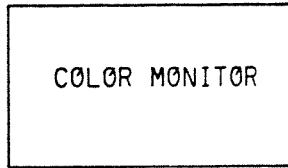

V REQUIRED POWER CAPACITY

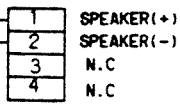

JST 4PIN POST W/BASE
B4P-SHF-1
2.5MM PICTH

PARTS SIDE B A SOLDER SIDE

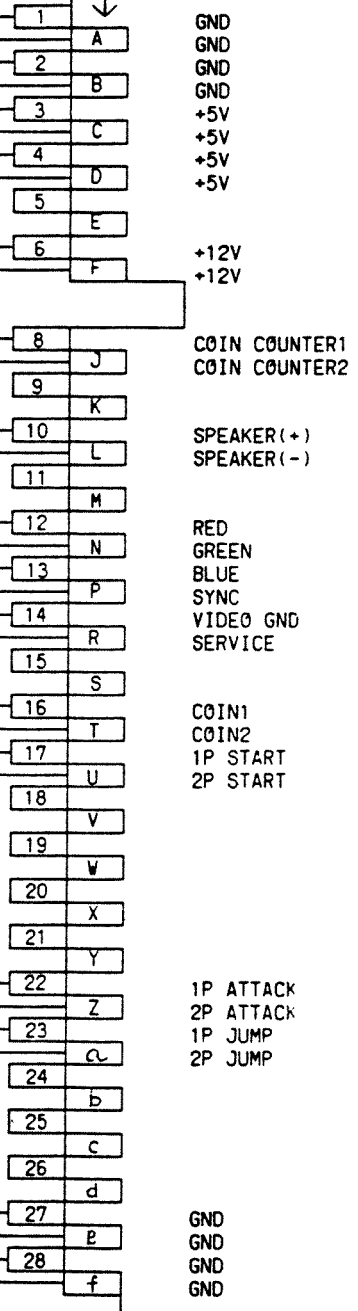
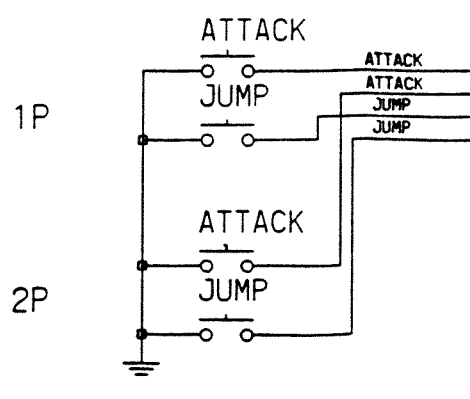
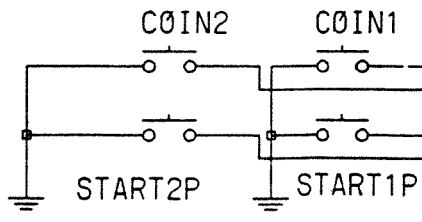
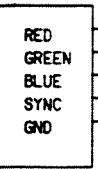
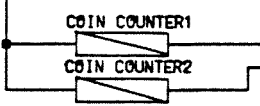
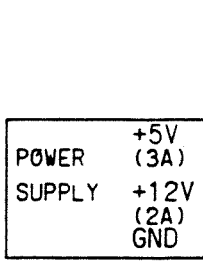

JAMMA 56PIN EDGE CONNECTOR
5/32 INCH PITCH

COMPLETE COIN DOOR ASSEMBLY

EXPLODED VIEW

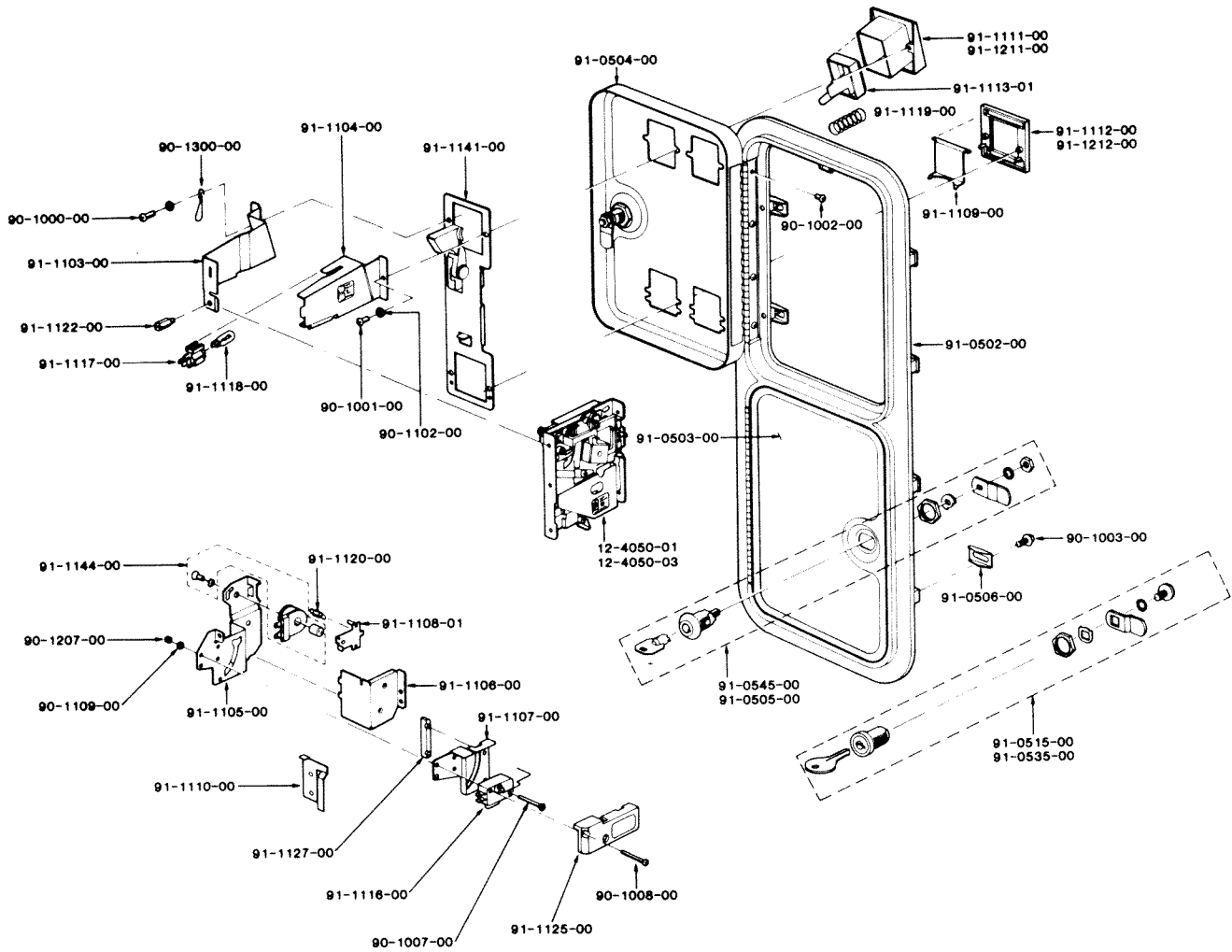

PARTS LIST

12-4050-01 S-10 Acceptor Body US 25¢	90-1102-00 Washer for Bezel Screw	91-1103-00 Coin Inlet Lamp Side	91-1119-00 Button Spring
12-4050-03 S-10 Acceptor Body Canadian 25¢	90-1207-00 Nut for Microswitch Mounting Screw	91-1104-00 Coin Inlet Cover Side	91-1120-00 Lockout Spring
20-4177-00 Plastic Cash Box	90-1300-00 Keyhook	91-1105-00 Reject Cup Side Plate	91-1122-00 Retaining Screw for Acceptor Body
20-4179-00 Steel Enclosure	91-0502-00 Zinc Die Cast Frame	91-1106-00 Reject Cup Base Plate	91-1125-00 Clear Plastic Cover for Microswitch
22-1400-00 Locking Bar	91-0503-00 Lower Door	91-1107-00 Microswitch Bracket	91-1127-00 Plastic Switch Adjuster
24-1150-00 Wire Harness	91-0504-00 Upper Door	91-1108-01 Lockout Flap US 25¢	91-1141-00 Base Plate With Pivot and Stud
90-1000-00 Keyhook Bezel Screw	91-0505-00 Round Lock and Cam Assembly	91-1109-00 Reject Flap	91-1144-00 6 Volt DC Lockout Coil Assembly
90-1001-00 Bezel Screw	91-0506-00 Clamp	91-1110-00 Metal Switch Adjuster	91-1211-00 Zinc Plated Button Bezel
90-1002-00 Hinge Screw	91-0515-00 Flat Lock and Cam Assembly	91-1111-00 Black Button Bezel	91-1212-00 Zinc Plated Reject Bezel
90-1003-00 Clamp Screw	91-0535-00 Flat Lock and Cam Assembly	91-1112-00 Black Reject Bezel	
90-1007-00 Flat Head Microswitch Mounting Screw	91-0545-00 Round Lock and Cam Assembly	91-1113-01 Entry/Reject Button US 25¢	
90-1008-00 Panhead Microswitch Mounting Screw		91-1116-00 Microswitch (Black End Arm)	
		91-1117-00 Lampholder	
		91-1118-00 6 Volt Wedge Base Lamp	

Gold Mech

Engineering Data and Parts List

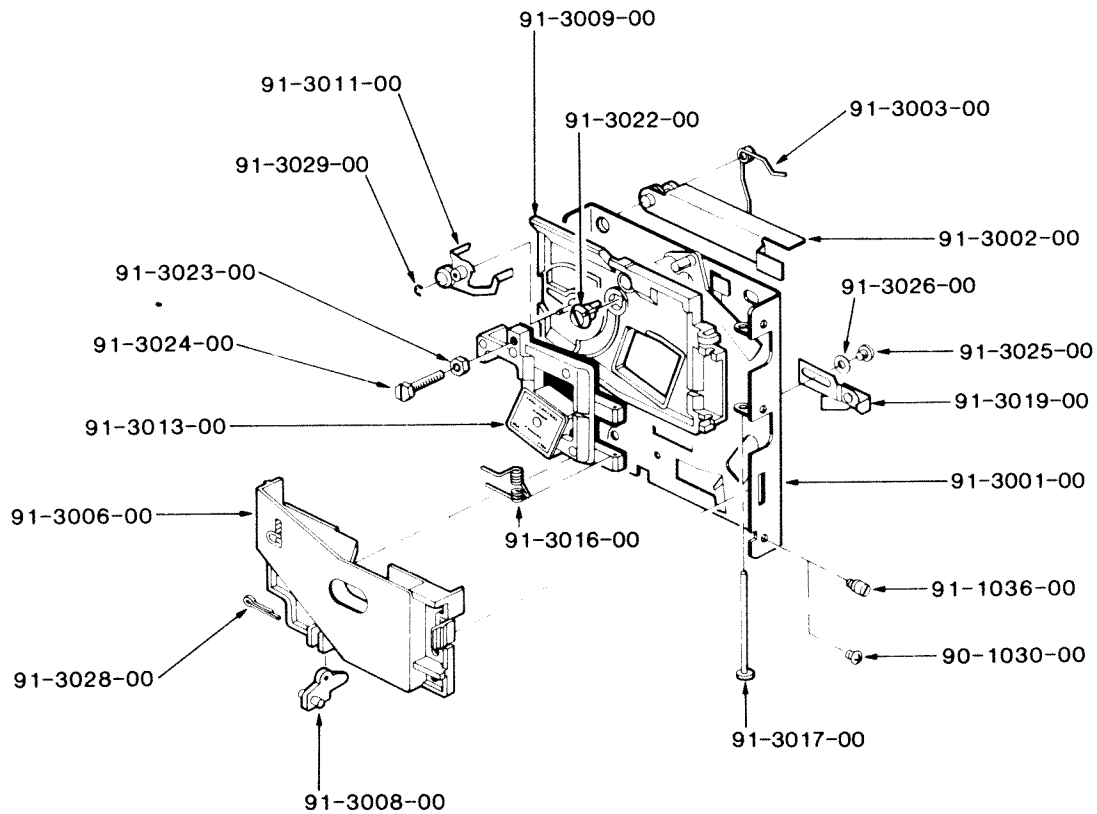

PARTS LIST

90-1030-00 Retaining Screw (#6-32" x .250")	91-3009-00 Gate	91-3023-00 Locknut-Magnet Holder
91-1036-00 Mounting Stud	91-3011-00 Cradle	91-3024-00 Screw-Magnet Holder
91-3001-00 Back Plate	91-3013-00 Magnet Holder with Magnet	91-3025-00 Screw Separator
91-3002-00 Reject Lever	91-3016-00 Gate Spring	91-3026-00 Washer
91-3003-00 Reject Lever Spring	91-3017-00 Gate Pin	91-3028-00 Cotter Pin for Anti-Stringing Device
91-3006-00 Cover Plate	91-3019-00 Separator	91-3029-00 E-Clip for Cradle
91-3008-00 Anti-Stringing Device	91-3022-00 Diameter Adjustment	

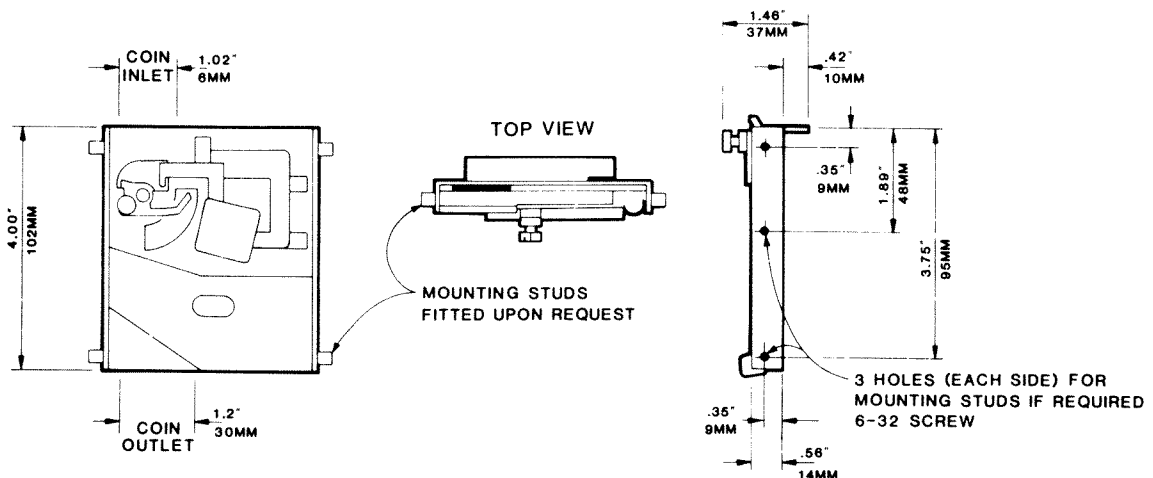
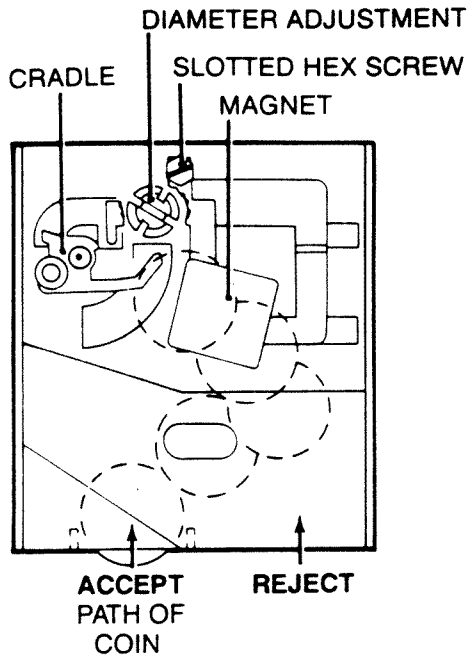

Fig. 4



The first check on the coin is at the entry slot which prevents the entry of grossly oversize and bent coins. The next test is at the cradle. When the correct coin falls into the cradle, the cradle tips and the coin is delivered to the magnet check. Under-diameter coins fall between the legs of the cradle and are returned to reject. Under-weight coins fail to tip the cradle and can be returned to reject by pressing the reject lever.

Adjustment

The Gold Mech Acceptors are factory adjusted for optimum performance. If more critical adjustments are desired, or if the unit has been disassembled, the following adjustment procedure is suggested. (Fig. 4).

1. Ensure that the mechanism is in an upright and level position.
2. Loosen the hex locking screw on the magnet holder and unscrew the slotted hex screw.
3. Place a true U.S. 25¢ coin in the mechanism. Turn the diameter adjustment (Fig. 4) clockwise until the coin falls into the cradle. The cradle should tip and the coin come to rest on the side of the magnet. Turn the slotted hex screw clockwise until the coin just clears the magnet. Give this screw a further 1/2 turn clockwise for optimum clearance and tighten the locknut.

Base Plate Assembly for Coin Doors and Front Plates

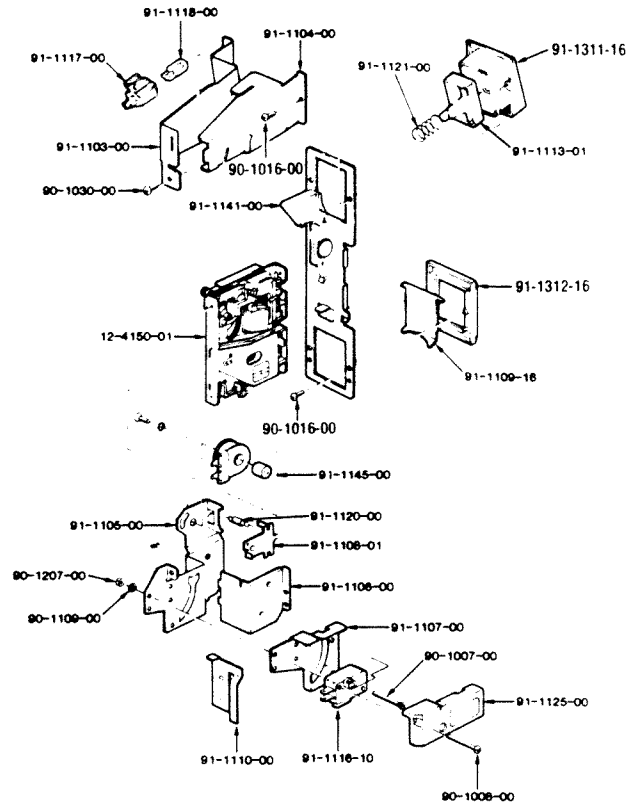

Part Number	Description
12-4150-01	Gold Mech Acceptor
90-1000-00	Keyhook Bezel Screw
90-1007-00	Flat Head Microswitch Mounting Screw
90-1008-00	Pan Head Microswitch Mounting Screw
90-1016-00	CPJS/Bezel Screw
90-1030-00	Mounting Screw for Gold Mech
90-1032-00	Bezel/Hinge Screw PZ
90-1109-00	Lock Washer for Microswitch Assembly
90-1207-00	Nut for Microswitch Mounting Screw
91-1103-00	Coin Inlet Lamp Side
91-1104-00	Coin Inlet Cover Side
91-1105-00	Reject Cup Side Plate
91-1106-00	Reject Cup Base Plate
91-1107-00	Microswitch Bracket
91-1108-01	Lockout Flap U.S. 25¢
91-1109-16	Reject Flap
91-1110-00	Metal Switch Adjuster
91-1113-01	Entry/Reject Button U.S. 25¢
91-1116-10	Microswitch (Red End Arm)
91-1117-00	Lampholder
91-1118-00	GV Wedge Base Lamp
91-1120-00	Lockout Spring
91-1121-00	Button Spring
91-1125-00	Clear Plastic Cover for Microswitch
91-1141-00	Base Plate w/Pivot Coil
91-1145-00	12 V DC Lockout Coil
91-1311-16	Black Nylon Button Bezel
91-1312-16	Black Nylon Reject Bezel

Gold Mech: Service Information

CLEANING and CARE of the MECHANISM

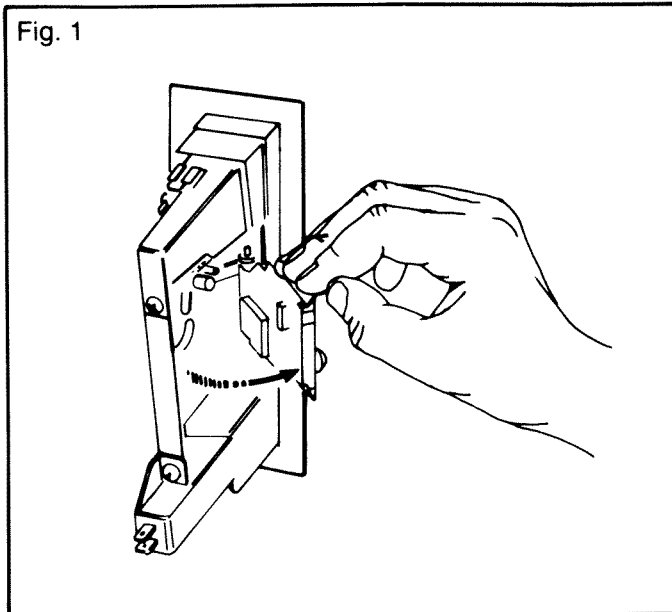

The magnet that is fitted to the mechanism, should be kept clean from foreign particles. The magnet can be cleaned by swinging the gate open. (as shown in Fig. 1). Remove metal filings from the magnet by guiding the point of a screwdriver along the edges of the magnet, such that the filings cling to the screwdriver.

The mechanism can be cleaned by immersing in water using a small brush to clean the mechanism. Rinse the mechanism with boiling water and dry with compressed air.

Note:

Since the Gold Mech relies on coins passing the magnet at a constant speed, the rejector must be free of dirt and grease which may slow down the coins. Do not lubricate the acceptor with oil as this slows down coins.

If the above procedures are not successful, check for worn, bent or damaged parts and replace where necessary.

Coin switch

The coin switch comes in two different spring tensions—identified by the color of the plastic boss at the wire's pivot point.

Red: Light tension—U.S. 25¢

White: Heavy tension—heavy foreign coins

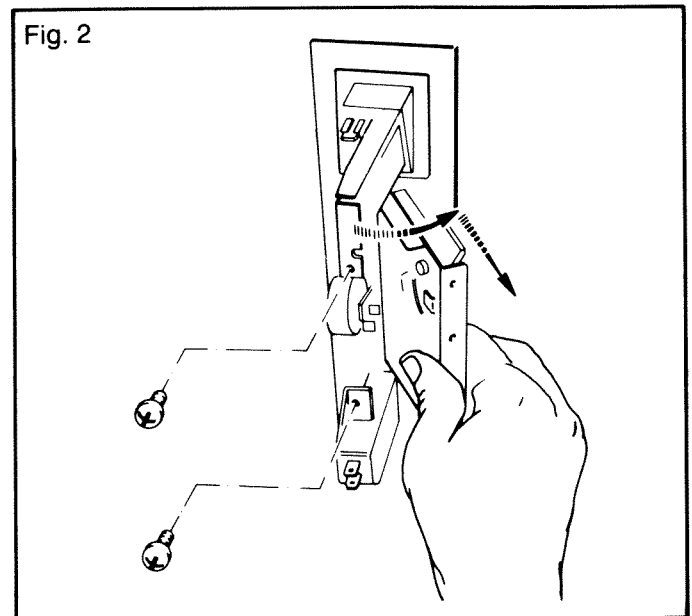

Removal of Mechanism

To remove the coin selector: Unscrew the two screws (as shown in Fig. 2)—swing rear of selector body away from the lock-out side and withdraw.

The Gold Mech Acceptors are designed to require a minimum of maintenance and field adjustment. Coins are checked by diameter and thickness, weight, metal content, bounce, and for ferromagnetic coins such as nickel and steel, a rim test is also used.

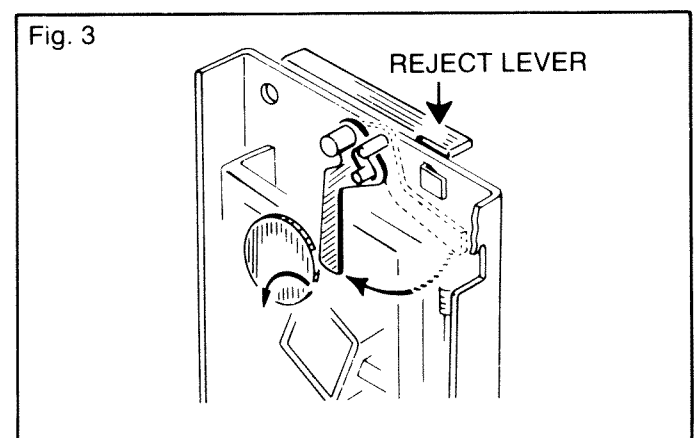

The Magnet

Coins that are too thick will fail to pass between the magnet and the backplate of the mechanism; and will be cleared by the magnet wiper when the reject lever is actuated. (Fig. 3)

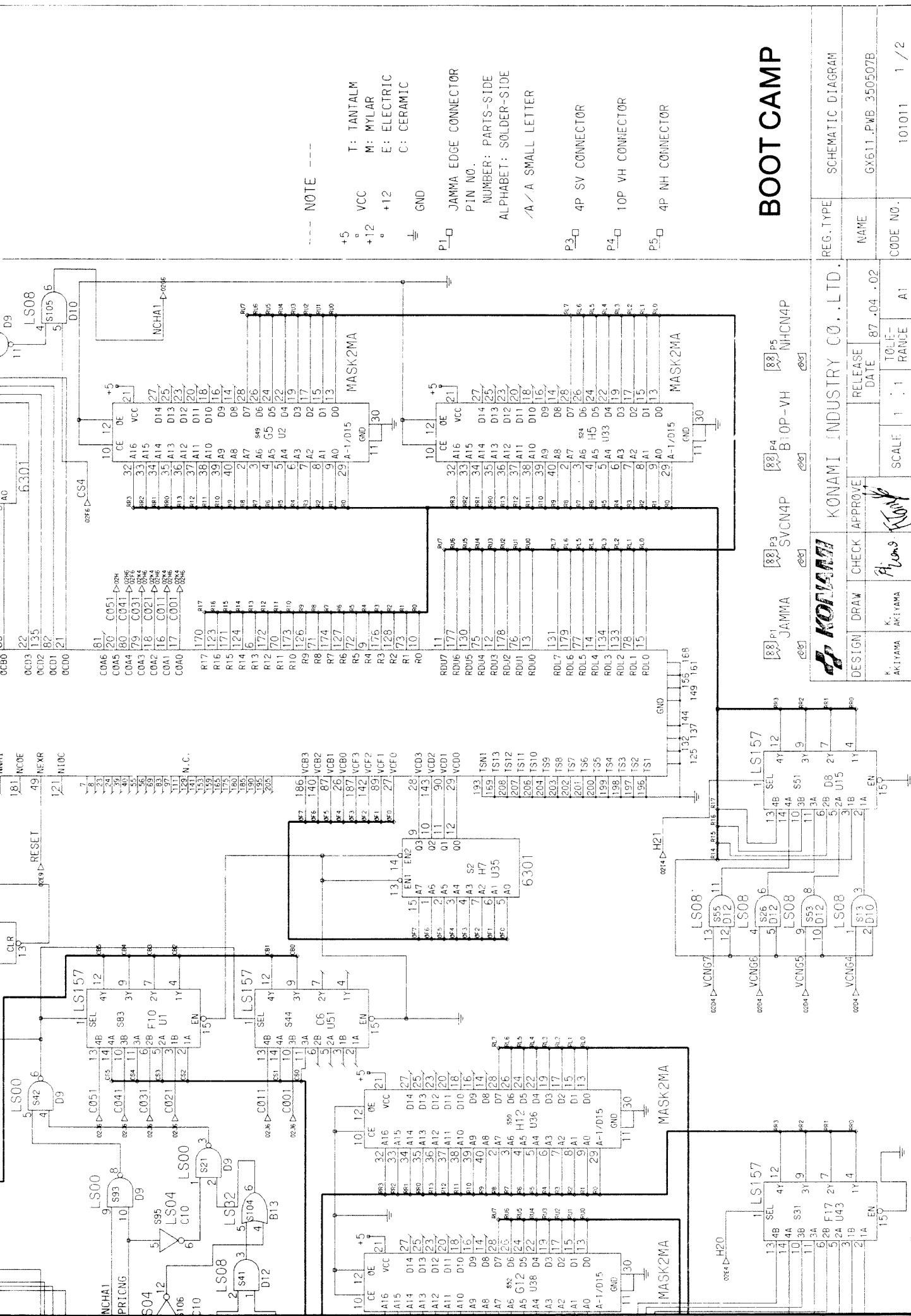

NOTE ---
 T: TANTALUM
 M: MYLAR
 E: ELECTRIC
 C: CERAMIC

+5 VCC
 +12
 GND
 P1- JAMMA EDGE CONNECTOR
 PIN NO.
 NUMBER: PARTS-SIDE
 ALPHABET: SOLDER-SIDE
 /A / A SMALL LETTER

BOOT CAMP

REG. TYPE	SCHEMATIC DIAGRAM
NAME	GX6.11..PWB_350507B
CODE NO.	101011 1 / 2

DESIGN	K. AKIYAMA	DRAW	K. AKIYAMA	CHECK	Flow	APPROVE	Flow
JAMMA	88P1	SVCN4P	88P3	Bi:Op-VH	88P4	NHCN4P	88P5
RELEASE DATE	87.04.02	SCALE	1:1	TOLERANCE	A1		

KONAMI							
KONAMI INDUSTRY CO., LTD.							

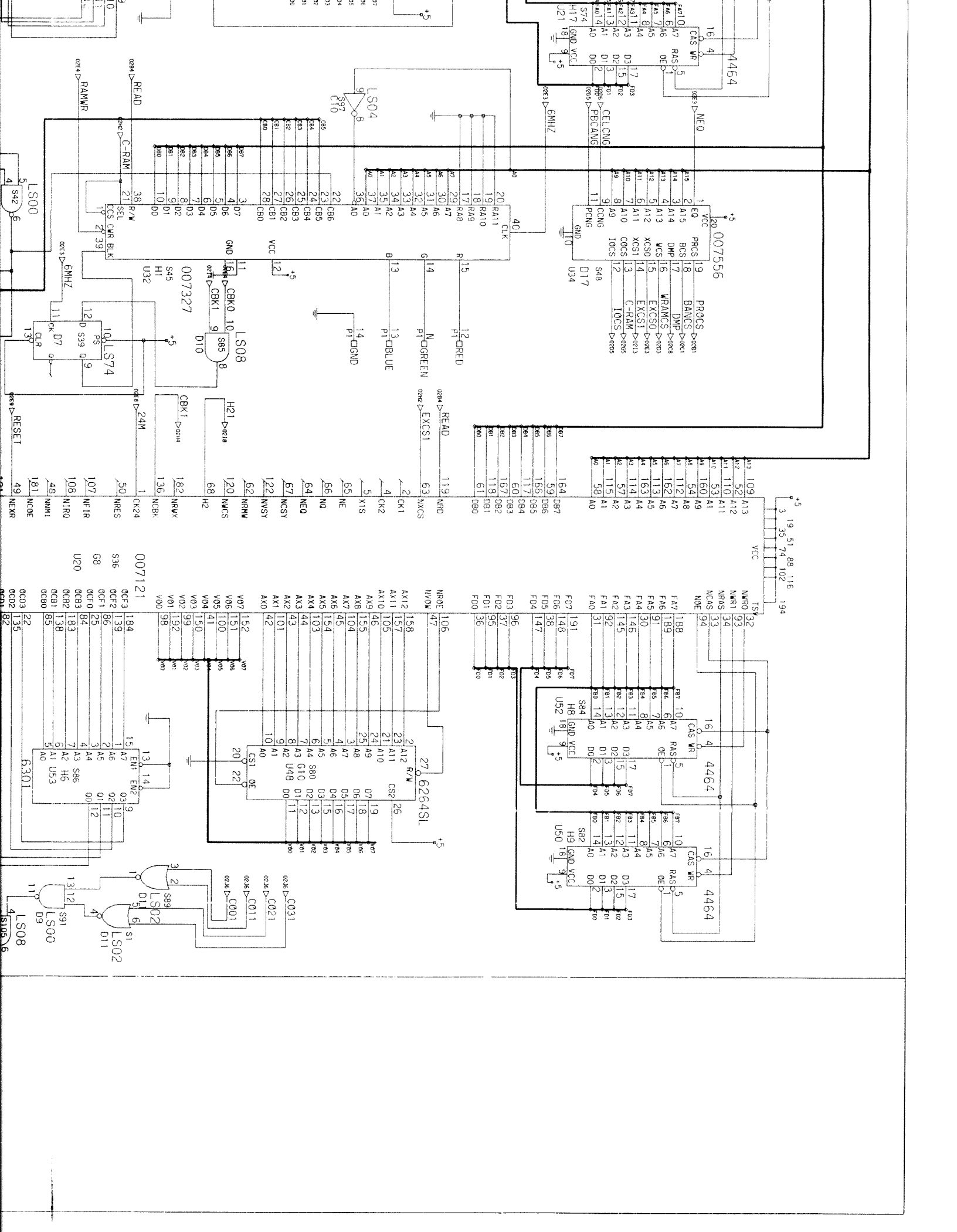

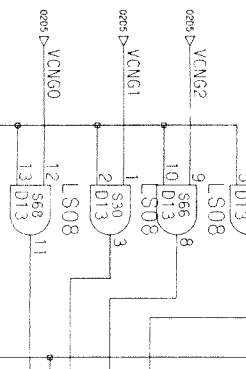
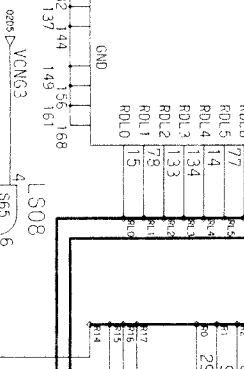
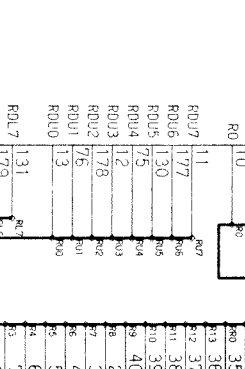
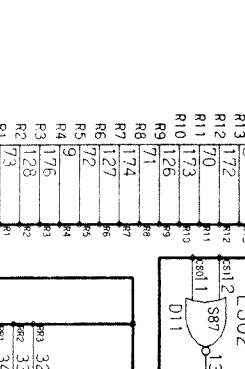
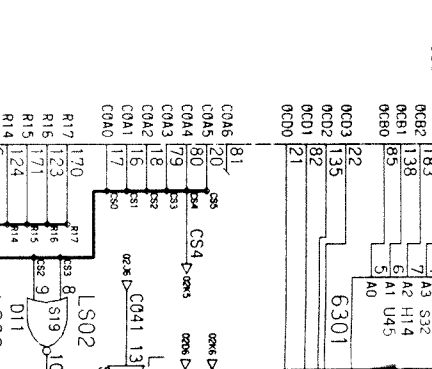
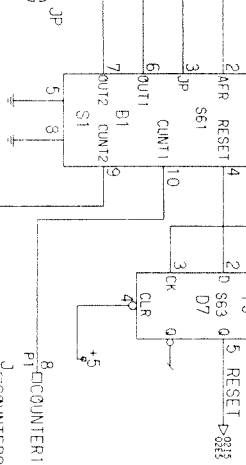
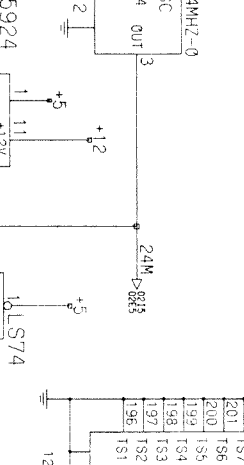
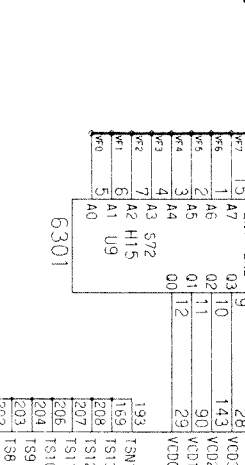
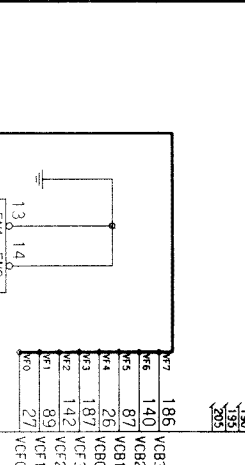
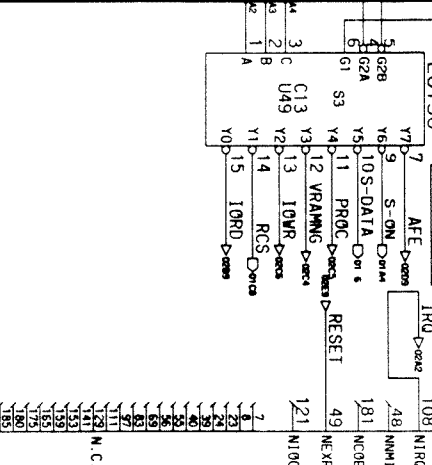
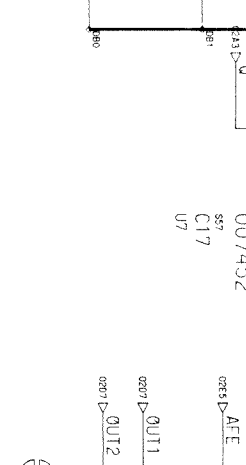
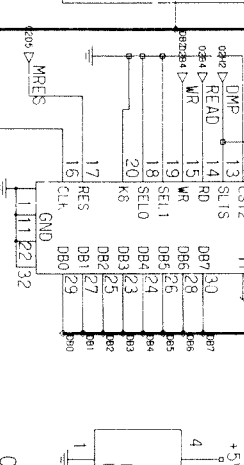
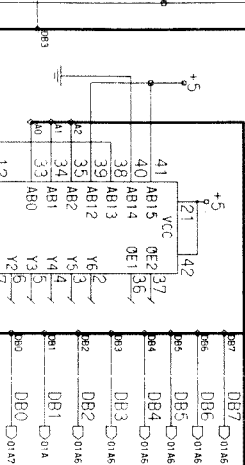
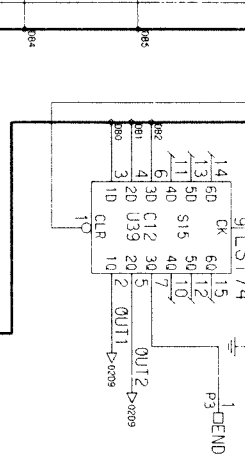
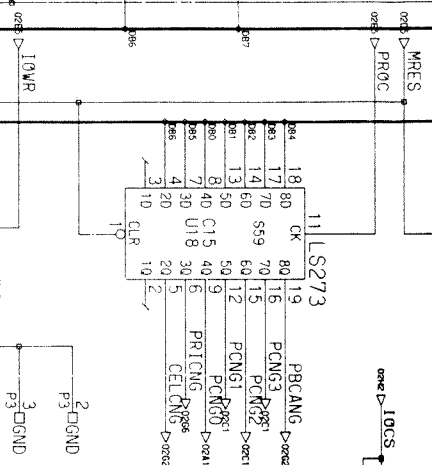
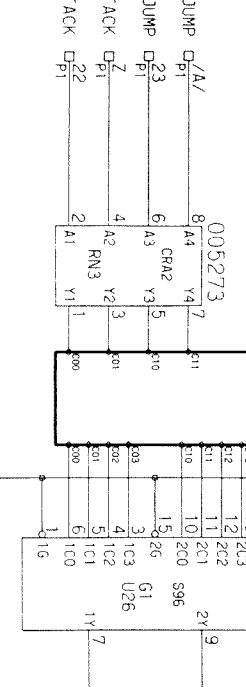
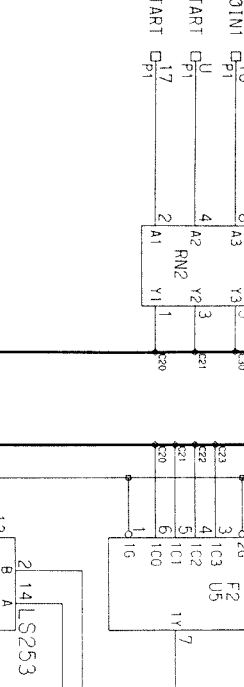
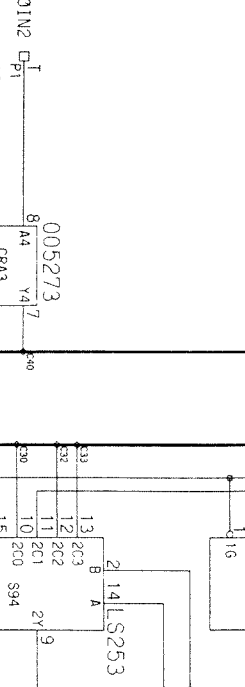
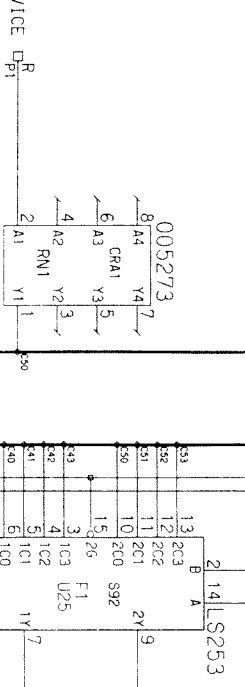
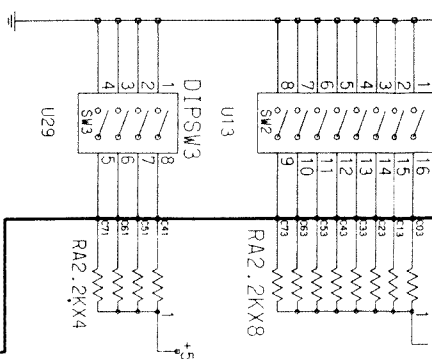
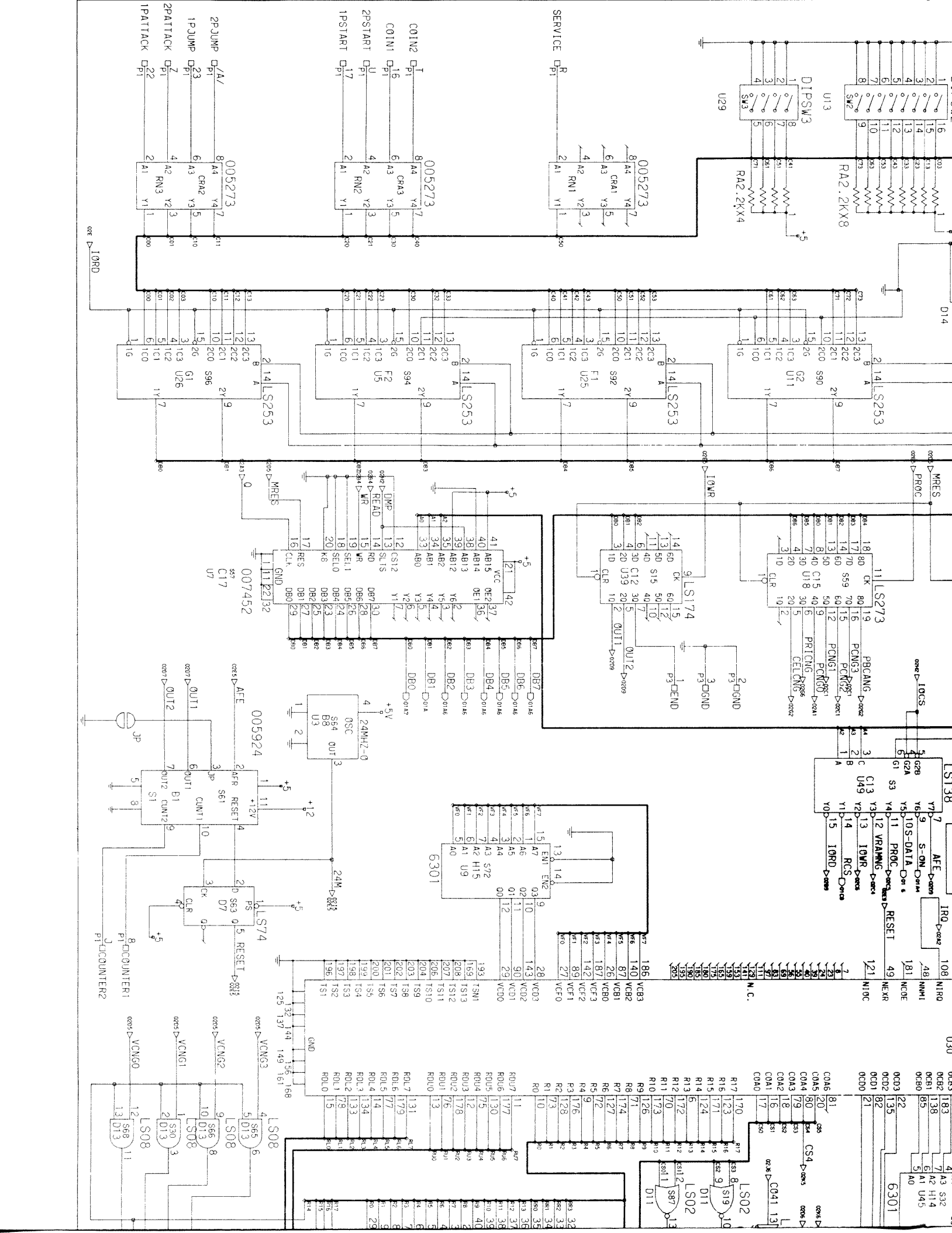

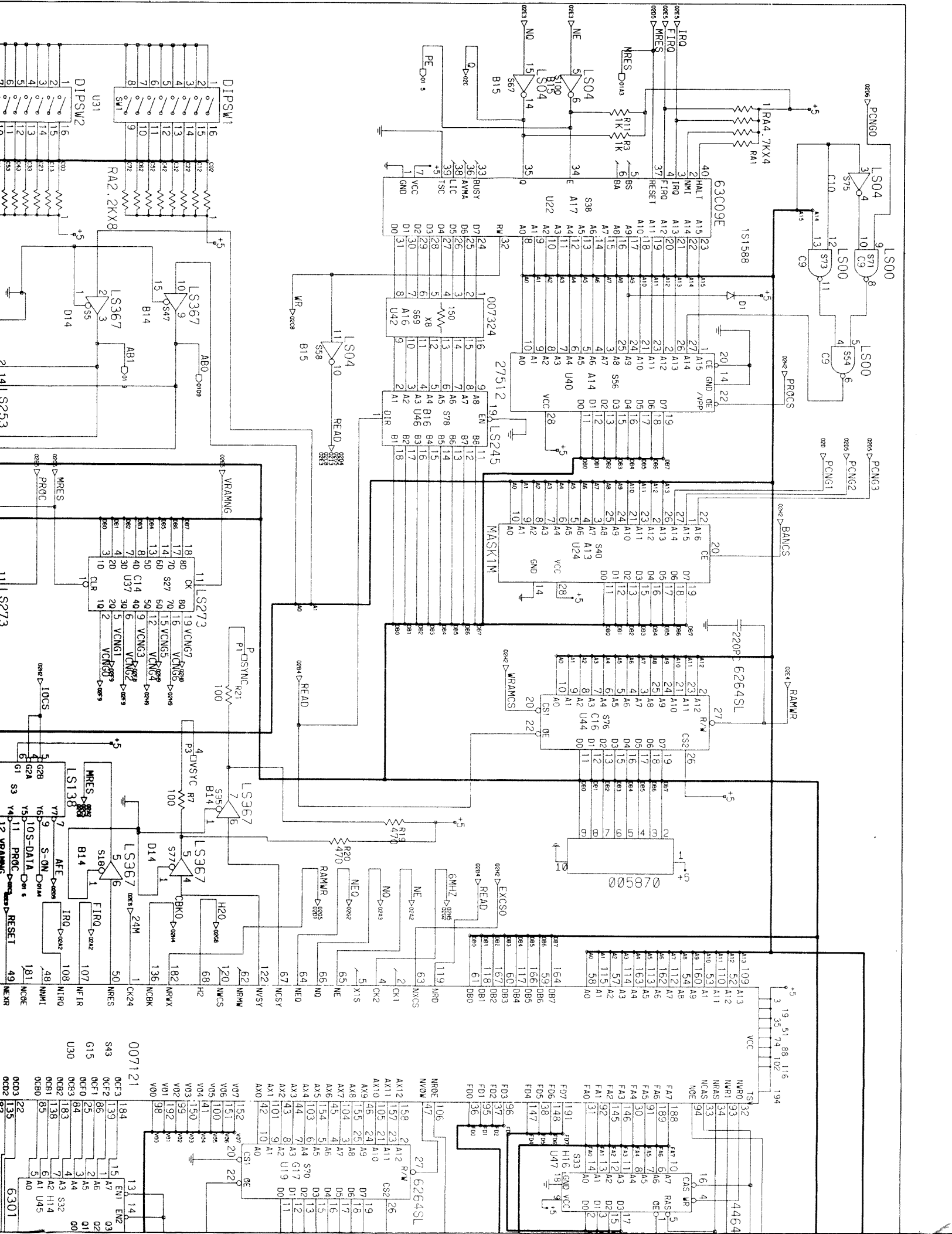

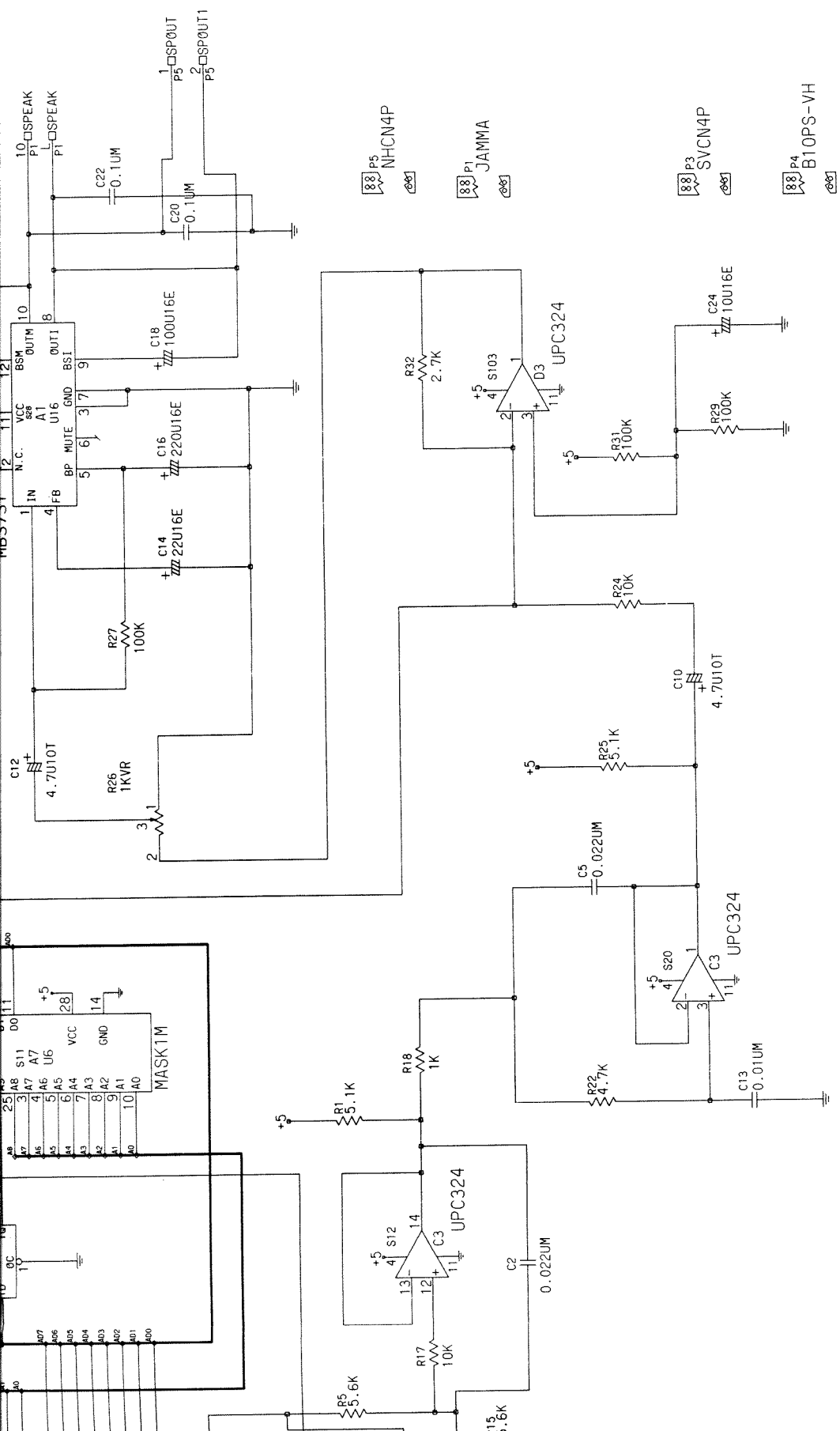

--- NOTE ---

- +5 VCC
- +12 M: MYLAR
- ° +12 E: ELECTRIC
- ⊥ GND C: CERAMIC

- P1 JAMMA EDGE CONNECTOR
- PIN NO.
- NUMBER: PARTS-SIDE
- ALPHABET: SOLDER-SIDE
- /A: SMALL LETTER

- P3 4P SV CONNECTOR
- P4 10P VH CONNECTOR
- P5 4P NH CONNECTOR

BOOT CAMP

KONAMI		KONAMI INDUSTRY CO., LTD.		REG. TYPE	SCHEMATIC DIAGRAM	
DESIGN	DRAW	CHECK	APPROVE	NAME	GX611_PWB_350507B	
K. AKIYAMA	K. AKIYAMA	A.	<i>[Signature]</i>	RELEASE DATE	87.04.02	
				SCALE	1:1	TOLERANCE
						A1
				CODE NO.	101011	2/2

