

Challenger

SERVICE MANUAL

MANUAL NO.
374-10-0100

centuri inc.

CHALLENGER

CENTURI, INC.
245 W. 74TH PLACE
HIALEAH, FLA. 33014

CUSTOMER SERVICE:
TEL. #(305) 558-5200 (IN FLORIDA)
TEL. #(800) 327-7710 (OUTSIDE FLORIDA)
TELEX: 803694 ANSB CENTURI CABLE: CENTURI

CHALLENGER
TABLE OF CONTENTS

<u>I. INTRODUCTION:</u>	<u>PAGE NO.</u>
USER INFORMATION.....	1
FRONT VIEW CHALLENGER CABINET(FIGURE 1).....	2
FRONT VIEW CABINET PARTS LIST FOR FIGURE 1.....	3
GAME DESCRIPTION SUMMARY.....	4
<u>II. OPERATION:</u>	
GAME INSTRUCTIONS AND POINT SCORING.....	5
OPTIONAL SWITCH SETTINGS.....	6
SYSTEMS DIAGNOSTICS.....	7,8,9
<u>III. SPECIFICATIONS:</u>	
INSTALLATION AND ELECTRICAL REQUIREMENTS.....	10
ROUTINE MAINTENANCE AND SERVICE.....	11
110/220 VAC CONVERSION INSTRUCTIONS.....	12
110/220 VAC CONVERSION DIAGRAM(FIGURE 2).....	13
<u>IV. GAME PART DRAWINGS, PART LISTS, AND SCHEMATICS</u>	
FRONT PLATE EXPLODED VIEW(FIGURE 5).....	14
FRONT PLATE EXPLODED VIEW PARTS LIST FOR FIG. 5.....	15
COIN DOOR EXPLODED VIEW OF OPERATING MECHANISMS(FIGURE 6).....	16
COIN DOOR EXPLODED VIEW PARTS LIST FOR FIG. 6.....	17
COIN DOOR EXPLODED VIEW(FIGURE 7).....	18
COIN DOOR EXPLODED VIEW PARTS LIST FOR FIG. 7.....	19
SHINDENGEN POWER SUPPLY PARTS LIST.....	20,21
PERIPHERAL INTERFACE BOARD A-30(374-13-0100) PARTS LIST.....	22
VIDEO INTERFACE BOARD A-20(374-13-0200) PARTS LIST.....	23
AUDIO COMPUTER BOARD A-25(374-13-0300) PARTS LIST.....	24
MICRO COMPUTER BOARD, REV. C (374-13-0400) PARTS LIST.....	25
CHALLENGER CONTROL PANEL & PARTS LIST(FIGURE 3).....	26
CHALLENGER CONTROL PANEL HARNESS(374-12-0500).....	27
GAMMA II COIN DOOR MODIFIED(374-10-0400).....	28
COIN DOOR HARNESS(374-10-0400).....	29
ELECTROHOME & WELLS-GARDNER MONITOR SIGNAL HARNESS(374-12-0300).....	30
P.C.B. POWER HARNESS(374-12-0600).....	31
D.C. OUTPUT POWER HARNESS(374-12-0200).....	32
SPEAKER OUTPUT POWER HARNESS(374-12-0400).....	33
PERIPHERAL POWER HARNESS(374-12-0700).....	34
AUDIO BOARD FLAT CABLE HARNESS(374-12-0100).....	35

CHALLENGER
TABLE OF CONTENTS

IV.	<u>GAME PART DRAWINGS, PART LISTS, AND SCHEMATICS (CONT'D):</u>	<u>PAGE NO.</u>
	PERIPHERAL BOARD FLAT CABLE HARNESS (374-12-0900).....	36
	VIDEO BOARD FLAT CABLE HARNESS (374-12-1000).....	37
	CABINET POWER HARNESS (370-12-0200A).....	38
	SHINDENGEN POWER SUPPLY (363-17-0300).....	39
	COMPLETE GAME LESS PKG. (374-01-0200).....	40
	GAMMA II PERIPHERAL INTERFACE BD. SCHEMATIC (374-17-0100).....	41
	GAMMA II AUDIO COMPUTER BOARD SCHEMATICS (374-17-0300).....	42, 43
	GAMMA II VIDEO INTERFACE BOARD SCHEMATIC (374-17-0400).....	44
	GAMMA IIC MICRO COMPUTER BOARD SCHEMATIC (374-17-0200).....	45

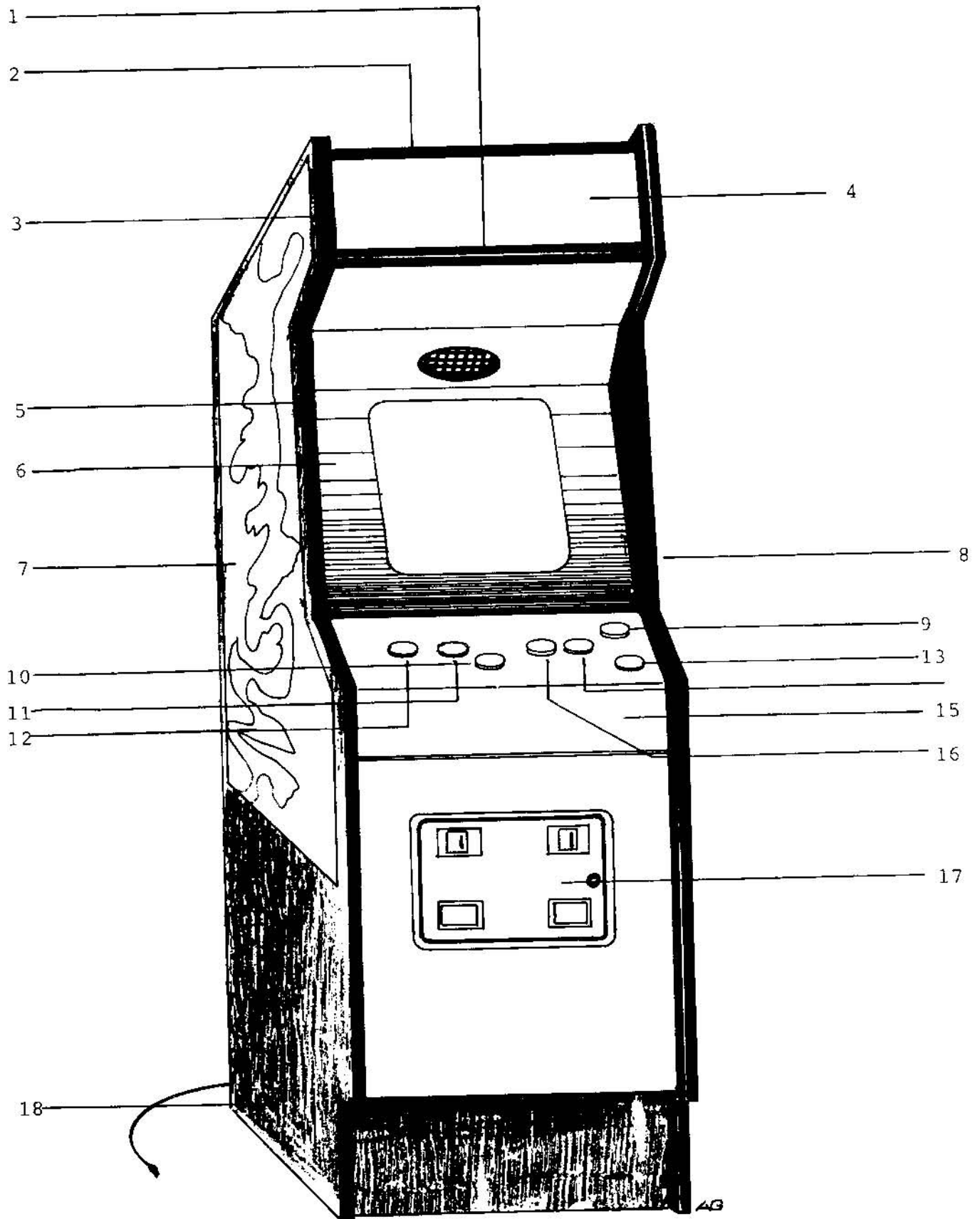

CHALLENGER UPRIGHT
(figure 1)

CABINET
(FIGURE 1)
PARTS LIST

<u>NO.</u>	<u>CENTURI P/N:</u>	<u>DESCRIPTION:</u>
1.	361-06-0100	MARQUEE BOTTOM HOLD DOWN BRKT.
2.	343-03-0200	MARQUEE TOP HOLD DOWN BRKT.
3.	361-10-0200	VINYL TRIM, 7 1/4" LONG
4.	374-06-0100	SILK SCREENED MARQUEE PANEL
5.	374-06-0500	SILK SCREENED MONITOR OVERLAY
6.	361-04-1000	VIEWING GLASS
7.	374-06-0200	LEFT HAND SIDE DECAL
8.	374-06-0300	RIGHT HAND SIDE DECAL
9.	-----	ONE PLAYER BUTTON
10.	-----	WARP BUTTON
11.	-----	LEFT MOTION BUTTON
12.	-----	RIGHT MOTION BUTTON
13.	-----	TWO PLAYER BUTTON
14.	-----	FIRE BUTTON
15.	374-14-0100	CONTROL DECK WIRED ASS'Y.
16.	-----	SUPER BOMB BUTTON
17.	374-10-0400	COINCO COIN DOOR (MODIFIED)
18.	361-12-0900A	A.C. LINE CORD HARNESS

CHALLENGER

CHALLENGER is the newest video game to be introduced by Centuri. With its vivid colors and lively setting, it is sure to lure the most ardent player into game action.

The game consists of sixteen sectors(rounds) of play. Sector one begins with Large Energy Rings floating randomly across the screen. The Spaceship must avoid colliding with the Rings, or it will explode into a starburst of brilliant colors. The Spaceship dodges the Energy Rings by moving right or left across the playfield, while bursting them with the Spaceship's 3-directional guns. Bursting the Large Rings(100 points), breaks them into Medium Rings. Bursting the Medium Rings(200 points), breaks them into Small Rings. Bursting the Small Rings(400 points), causes them to disintegrate.

The Spaceship is further protected by a feature called a "Warp" button. By depressing this button, the Spaceship will relocate from the top or bottom of the screen to the opposite side.

If the Spaceship is in ultimate danger of being destroyed, releasing its Super Bomb will wipe out all the objects on the playfield, and add the point value of the objects to your score. Use of the Super Bomb is lost, if the ship is destroyed first. Only one Super Bomb is awarded per Spaceship.

At any time, a colorful Space Bogey resembling a Worm may appear on screen and proceed to chase the Spaceship. If the Worm is destroyed by Spaceship fire, or dodged successfully for several seconds, a "clang" is heard and the Worm(500 points) wriggles off the screen in a bright red hue of embarrassment. If the Spaceship is caught by the Worm, a bell is sounded, and the astronaut is chased out of his ship in pursuit of safety.

At random time intervals a Bonus Bug will walk across the playfield, stop, and count down a Bonus Number. This number is equal to 100 times its value. To receive this Bonus, the Spaceship must link with the nose of the Bonus Bug.

When the Spaceship has survived 50 Seconds of playing time, it now enters the challenges of the next sector.

The remaining 15 sectors are played in the same manner as Sector one. The differences include that each succeeding sector increases in difficulty. The Energy Rings increase in number and move faster across the screen making them harder to dodge. Also there are several Space Bogeys introduced in the first 8 sectors. They also increase in number with advancement through each sector. Some of the Space Bogeys resemble Comets whizzing through space. Others resemble Spaceships from other worlds. Each Space Bogey(500 points), is an assemblage of bright colors, and when destroyed, burst with a "clang" into a spray of bright light.

Sectors 4, 8, 12, and 16, are alike as follows. A few seconds after the Energy Rings are broken into smaller pieces, they are pulled into a Black Hole in the center of the screen. While swirling across the game area, the condensed Rings expand and shatter into fragments which must be destroyed before they absorb the Spaceship.

When Sector 16 has been accomplished, it will return to Sector 9.

When Bonus levels are achieved, an additional Ship will be added to your game.

CHALLENGER INSTRUCTIONS

1. BURST ENERGY RINGS TO SCORE AND INCREASE BONUS LEVELS.
LARGE RINGS - 100 POINTS
MEDIUM RINGS - 200 POINTS
SMALL RINGS - 400 POINTS
2. AFTER ALL THE SMALL RINGS ARE HIT, ADVANCE TO THE NEXT SECTOR.
3. IN EACH SECTOR, SPACE BOGEYS APPEAR AND SCORE 500 POINTS WHEN HIT.
4. WHEN THE BONUS BUG WALKS ACROSS THE PLAYFIELD AND STOPS, BONUS POINTS ARE COUNTED DOWN. TO COLLECT THE BONUS, LINK THE SHIP WITH NOSE OF THE BUG.
5. PRESSING THE WARP BUTTON IMMEDIATELY RELOCATES THE SHIP FROM THE TOP OR BOTTOM OF THE PLAYFIELD TO THE OPPOSITE SIDE.
6. THE SUPER BOMB BUTTON DESTROYS ALL OBJECTS ON THE PLAYFIELD SCREEN AND AWARDS TOTAL POINT VALUE TO YOUR SCORE.
7. ONE SUPER BOMB IS AWARDED PER SHIP. USE OF IT WILL BE LOST IF THE SHIP IS DESTROYED FIRST.
8. GAME IS OVER WHEN ALL THE SHIPS HAVE BEEN DESTROYED.

Challenger

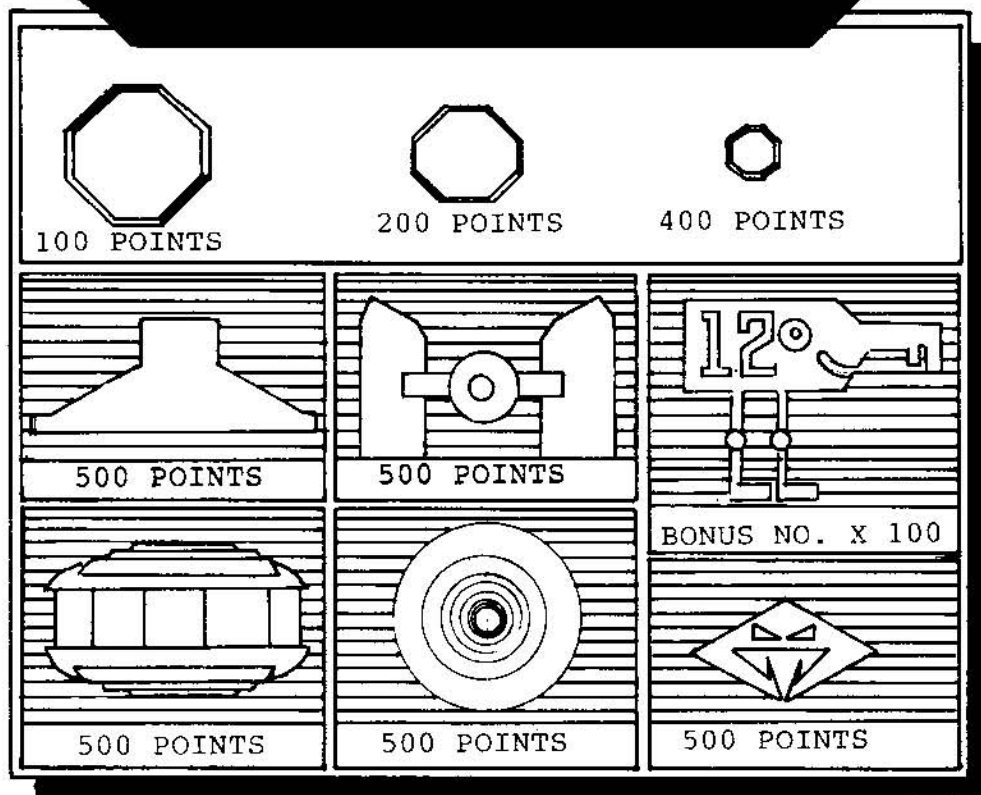

OPTIONAL SWITCH SETTINGS

The optional switch settings for the game are found on the C.P.U. Board. They will aid you in your game selection format.

Dip Switch A controls the number of coins per game, and also the the number of ships allotted per game. The following settings can also be found described on mode 6 of the self diagnostic test modes. (See System Diagnostics section for further explanation.)

DIP SWITCH A

Switches 1 and 2, of this switch, control the number of coins per game:

<u>SWITCH 1</u>	<u>SWITCH 2</u>	<u>COINS PER GAME</u>
Off	Off	1 Coin per game
On	Off	2 Coins per 1 game <u>or</u>
		3 Coins per 2 games
Off	On	2 Coins per game
On	On	Free Play

Switches 3 through 6 are factory settings. They are to remain in the OFF position.

Switches 7 & 8 control the number of ships allotted per game:

<u>SWITCH 7</u>	<u>SWITCH 8</u>	<u>NO. OF SHIPS PER GAME</u>
Off	Off	3
On	Off	4
Off	On	5
On	On	6

Dip Switch B controls the number of points at which a Bonus Ship is awarded, as well as some factory settings also described on mode six of the self diagnostic test modes.

DIP SWITCH B

Switches 1 through 3 control the Bonus Ship for different point levels.

<u>SWITCH 1</u>	<u>SWITCH 2</u>	<u>SWITCH 3</u>	<u>BONUS SHIP AWARDED AT</u>
On	On	On	30,000 Points
Off	Off	Off	40,000 Points
On	Off	Off	50,000 Points
Off	On	Off	60,000 Points
On	On	Off	70,000 Points
Off	Off	On	80,000 Points
On	Off	On	90,000 Points

Switches 4 & 5 are factory settings and remain in the OFF position. Switches 6 & 7 are factory settings which remain in the ON position. Switch 8 - OFF for the upright game; ON for the Cocktail Table.

SYSTEMS DIAGNOSTICS

Programmed into the Challenger game is a feature called "Systems Diagnostics". This is a series of system level (game level as opposed to circuit level) tests which are used to aid a service operator in checking-out or setting-up a game on site. Regardless of the state of the game or position of the operator switch settings, entry into the test modes is possible as long as the power is on in the game. This is accomplished by depressing the test switch located on the inside of the coin door. By pressing this switch down, a momentary action results which advances you through the selection of test modes. By pressing the switch up, it is now placed in a detent position. This position is used in performing special tests within some of the modes. To exit from the test modes, activate the coin-switch or slam-switch, upon which the game automatically returns to the attract mode. Please note that test mode 7 is used to test the coin switches and exit from it can only be accomplished by stepping to another test mode or interrupting the power with the switch in a neutral position.

The test modes are numbered 0 through 9, with Mode 0 displaying the "diagnostic menu". This is merely the Table of Contents of all of the test modes. The following is a brief description of each of the nine mode selections:

COLOR FIELDS (Mode 1)

This test is comprised of a built-in, color bar generator. It is used to properly set-up the color monitor for color purity, static and dynamic convergence, and white balance. When Mode 1 is first entered the screen is all black with "TEST NO. 1 COLOR FIELDS" inscribed across the top. When the test switch is placed in a detent position (upward), the screen will automatically sequence cyclically through the 8 color fields (solid color rasters) of RED, GREEN, YELLOW (RED & GREEN), BLUE, MAGENTA (RED & BLUE), CYAN (GREEN & BLUE), WHITE (ALL ON), BLACK (ALL OFF). Any of these color fields can be selected by returning the test switch to a neutral position.

COLOR GRIDS (MODE 2)

This test displays crosshatch patterns. As in Mode 1, the switch in a detent position can be used to select any of the eight colors. The color grids fill the total image display on the monitor screen, so that size and position adjustments of the grid relate directly to the game image. These grids should be periodically used to check the monitor set-up for IMAGE SIZE, POSITION, SYNCHRONIZATION, LINEARITY, PINCUSHIONING, COLOR CONVERGEANCE, COLOR BALANCE. Image focus and brightness should be a final adjustment made on-site to the game, while in play.

CONTINUOUS VIDEO CLEAR (MODE 3)

The function of this test is to provide repetitive clear and write signals, so that the functions can be observed with synchronous test equipment such as oscilloscopes. When Mode 3 is entered, the

screen will go solid blue with "TEST NO. 3 CONT'. VIDEO CLEAR" displayed across the top in black. After a 2 second delay, the screen will begin flashing, indicating that repetitive "clear to blue" signals are being processed.

CONTINUOUS VIDEO WRITE (MODE 4)

When the test in this mode is entered, the monitor screen will be cleared to all black and "TEST NO. 4 CONT. VIDEO WRITE" will be displayed across the top of the screen in white. After a 2 second delay, a white diagonal line will appear from the upper-left to the lower-right screen. Although not apparent to the viewer, this line is being constantly redrawn to force the video X-Y write counters to cycle through binary up-counts.

Since the video RAMS are being continuously accessed, errors from defective or marginal RAMS will appear as spurious dots on the screen, and when errors are observed, the next test mode can then be entered to determine which RAMS are generating the erroneous dots.

VIDEO RAM LOCATOR (MODE 5)

Mode 5 is a unique diagnostic aid that uses the video display as well as the hardware configuration of the video computer to isolate problems down to chip level. There are 48 video RAM chips which are socketed and arranged in three groups of 16, corresponding to the 3 primary colors: Red, Green, and Blue. Whenever one of these chips is defective, spurious dots will appear on the screen.

For this test, vertical, white lines are spaced across the screen, and 3 pairs of letter-numbers appear in the middle of the screen. These pairs are "road-map" locators corresponding to the physical location of the 3 specific RAM chips on the video board. The locators are displayed in Blue, Green, and Red, and correspond to the 3 RAMS which generate the vertical white lines. If any of the white lines overlaps a noise dot, the locator indicates which chip generated that dot.

By moving the test switch up and then back to neutral immediately, the next set of RAMS is selected. The vertical lines appear wider since a second set of lines is drawn adjacent to the first set, and the RAM locators change to indicate the new set of RAMS which generate the new lines. Once again, if these white lines overlap a noise dot, then the locator will tell you which chip is generating that dot.

Activating the test switch to the detent position (upward), then back again to neutral can be repeated 16 times total. This process continues adding white lines to the screen until the entire image area is covered with white lines. It is helpful to experiment with this test by removing one of the RAM chips and find its location by using the video locator.

DIP SWITCHES (MODE 6)

Test Mode 6 serves a dual, first by checking the proper operation of the option DIP switches(A & B), and second by displaying all the possible switch options. The DIP switch positions are numbered and followed by the word OFF in Red. When a switch is turned ON, it will be written in Green, following the switch number. The best way

to verify proper operation of the DIP switches is as follows:

1. Turn all switches OFF.
2. Confirm all 16 OFF is displayed.
3. Turn all odd-numbered switched ON.
4. Confirm alternating ON-OFF is displayed.
5. Turn all remaining switches ON.
6. Confirm all 16 ON is displayed.
7. Turn all odd-numbered switches OFF.
8. Confirm alternating OFF-ON is displayed.
9. Turn all switches OFF.
10. Confirm return to all 16 OFF.

For various selections of the switch options, see the OPTIONAL SWITCH SETTINGS section of this manual.

COIN & START SWITCHES (MODE 7)

In this display, as in the previous test, the switches are numbered and followed by word OFF (in Red) or ON (in Green) when the switch is activated. There is also an additional column labeled LOCATOR, which provides the information concerning the connection of each switch to its harness. FOR EXAMPLE ONLY: If the SLAM switch locator is A30J1-4, this means that this switch is wired to Pin 4 of Connector J1 on assembly A30. When the SLAM switch is activated, the display should show COIN-DOOR switch number 3 ON. If it doesn't connect a jumper from the common of the connector to Pin 4. If the display shows ON, the problem is external to the computer system.

Each of the switches listed in this test display should be manually activated to verify proper electrical connections. However, most of these switches are critical switches, and the only true test of total operational performance is by actual use in a game environment. FOR EXAMPLE, multiple coins should be inserted in the coin-slot with the verification of proper tracking of the coins all the way to cash box, through proper credit accumulation and coin counting. Note that the SELECT TEST switch cannot be directly tested in this mode since its activation will sequence to the next test mode.

PLAYER SWITCHES (MODE 8)

The display format for this test is identical to test 7, except that it displays the player 1 and player 2 control switches. This test is also used to isolate problems, but performance testing must be obtained by operating the switches while playing an actual game.

AUDIO COMPUTER (MODE 9)

This test lists all the 15 sounds in the Challenger game. By putting the switch in the detent position (up), a sequence of sound effects will be heard. If the proper response is received by the Game Computer, the test will display OK in Green after the sound number. If not, it will write NO in Red. Either response indicates that the request was made. Thus this test provides a check on the Game-to Audio Computer link, when the sound system is not working or not properly connected.

INSTALLATION

Your game was shipped from the factory in ready-to-play condition. A brief inspection is suggested before the machine is removed from the carton. If there is damage to the shipping carton, contact the freight carrier for claim purposes. External damage could indicate possible damage to the cabinet and/or electronics components.

After the carton has been satisfactorily inspected, remove the machine from the shipping carton.

Examine the interior of the game for disconnected wires, cables, or harnesses. Make sure the electronic devices are securely mounted in their sockets, etc. Record the game serial number since it will be required for reference and servicing.

ELECTRICAL REQUIREMENTS

Unless otherwise specified, this game is set to operate at 110 Volts A.C. See Figure-2- and 110/220 VAC conversion instructions.

Power Supply Chassis schematic information and parts list are included in this manual.

ROUTINE MAINTENANCE & SERVICE

Because of the solid state electronic circuitry, this machine should require very little maintenance and only occasional adjustments. However, it is necessary to take measures to insure this.

The volume control is labeled, and located in the middle of the cabinet, and can be accessed through the rear cabinet door.

The video monitor has been properly adjusted before shipping. Occasionally minor adjustments are necessary. See monitor specifications and schematics for technical information. Adjustment controls for the monitor are located on the rear of the monitor.

This machine should be serviced only by a qualified technician.

Do not make any adjustments on this machine while power is on.

For service information, contact the Customer Service Department. The number and information is located on the first page of this manual.

POWER SUPPLY

The Computer Board in this game operates most efficiently and reliably when the power supply is set so that the voltage on the board is 5.0 Volts, ± 0.1 Volts. To check this, place a meter across the 5 Volts and ground at the edge of the connector. If necessary, adjust the screwdriver control on the power supply so the meter reads between 4.9 and 5.1 Volts.

110/220 VAC CONVERSION INSTRUCTIONS

This video game has a harness configuration that allows the machine to be operated from either a 110 VAC or 220 VAC, 50 or 60 Hz power source. All games shipped from Centuri, Inc., are in the 110 VAC configuration. To change to the 220 VAC configuration perform the following:

- FIRST: Unplug the machine from the wall outlet to completely eliminate shock hazards.
- SECOND: Remove the single 3 AMP slow-blow fuse in the A.C. Distribution Bracket, and install two(2) 1.5 AMP slow-blow fuses. Now cut the #18 AWG. white jumper wire at both ends of the fuse holder and replace the cover.
- THIRD: Locate the "orange" jumper plug marked 110 VAC on the game power transformer, on the floor of the machine. Unplug the "orange" jumper, and plug in the "red" jumper plug marked 220 VAC.

To change back to 110 VAC, replace the components changed in Steps above.

- *NOTE: The common side of the A.C. Line must not be fused in the 110 VAC configuration - Replace the #18 AWG., white jumper wire.

(SEE ALSO FIG. 2, 110/220 POWER INTERCONNECT DIAGRAM, #370-10-040C

ENTIAL
OUT THE

FIGURE 2

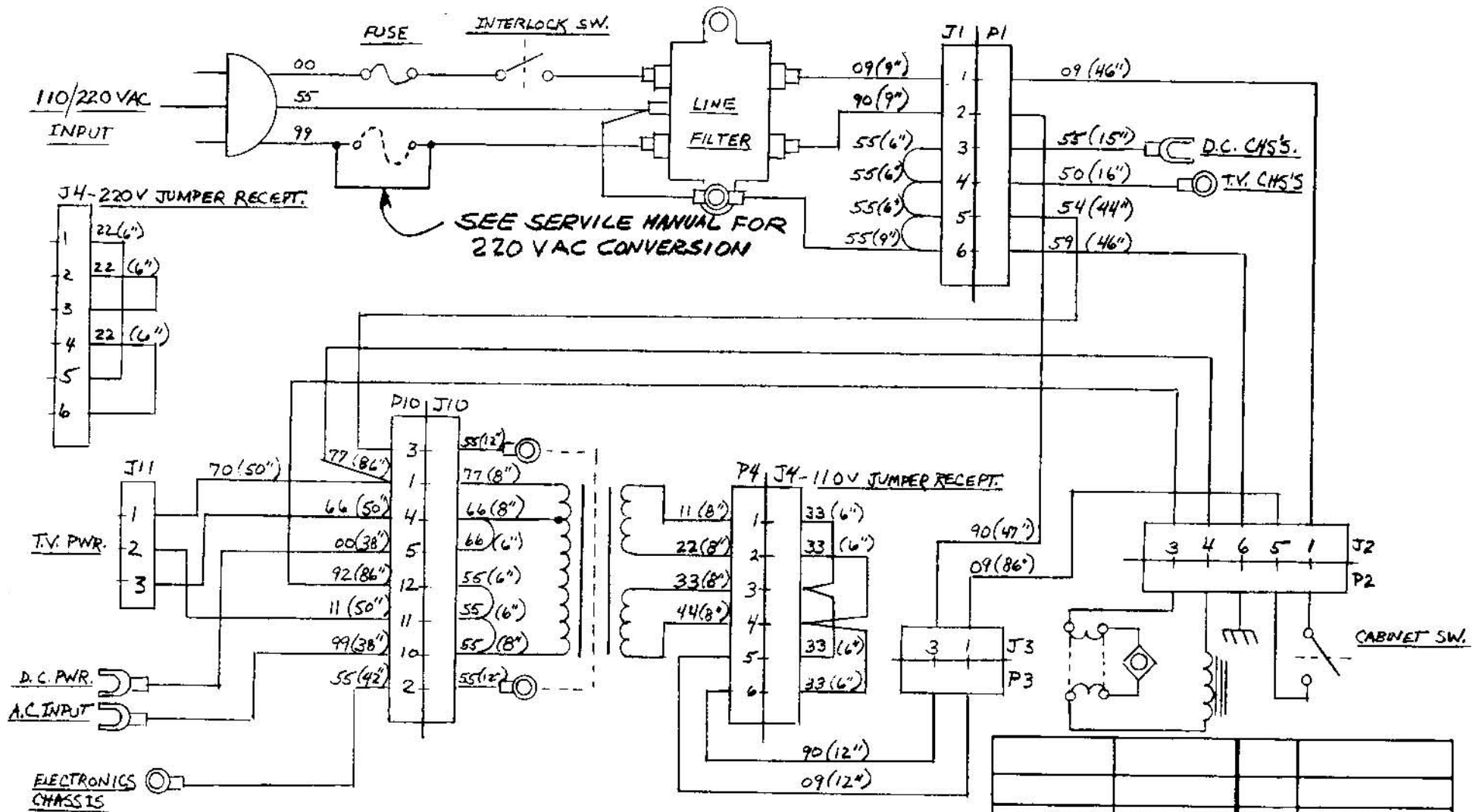

REV. LET.	ECN NO.	REVISION	BY	TOLERANCES		HIALEAH, FLORIDA 33014			
				Unless Otherwise Specified		NAME			
				FRACTIONS	± 1/32	110/220V POWER INTERCONNECT DIAG			
				DECIMALS 2 PL	± .015	MAT'L'S.		HEAT TREAT.	FINISH
				DECIMALS 3 PL	± .005				
				HOLES	+ .003	OWN	DATE	SCALE	PART NO.
				ANGLES	- .001	VAP	5-8-81		370-10-0400
				SHT. MET BENDS	± 2'				REV. A

**2800-0 FRONT PLATE EXPLODED VIEW
25¢ COIN**

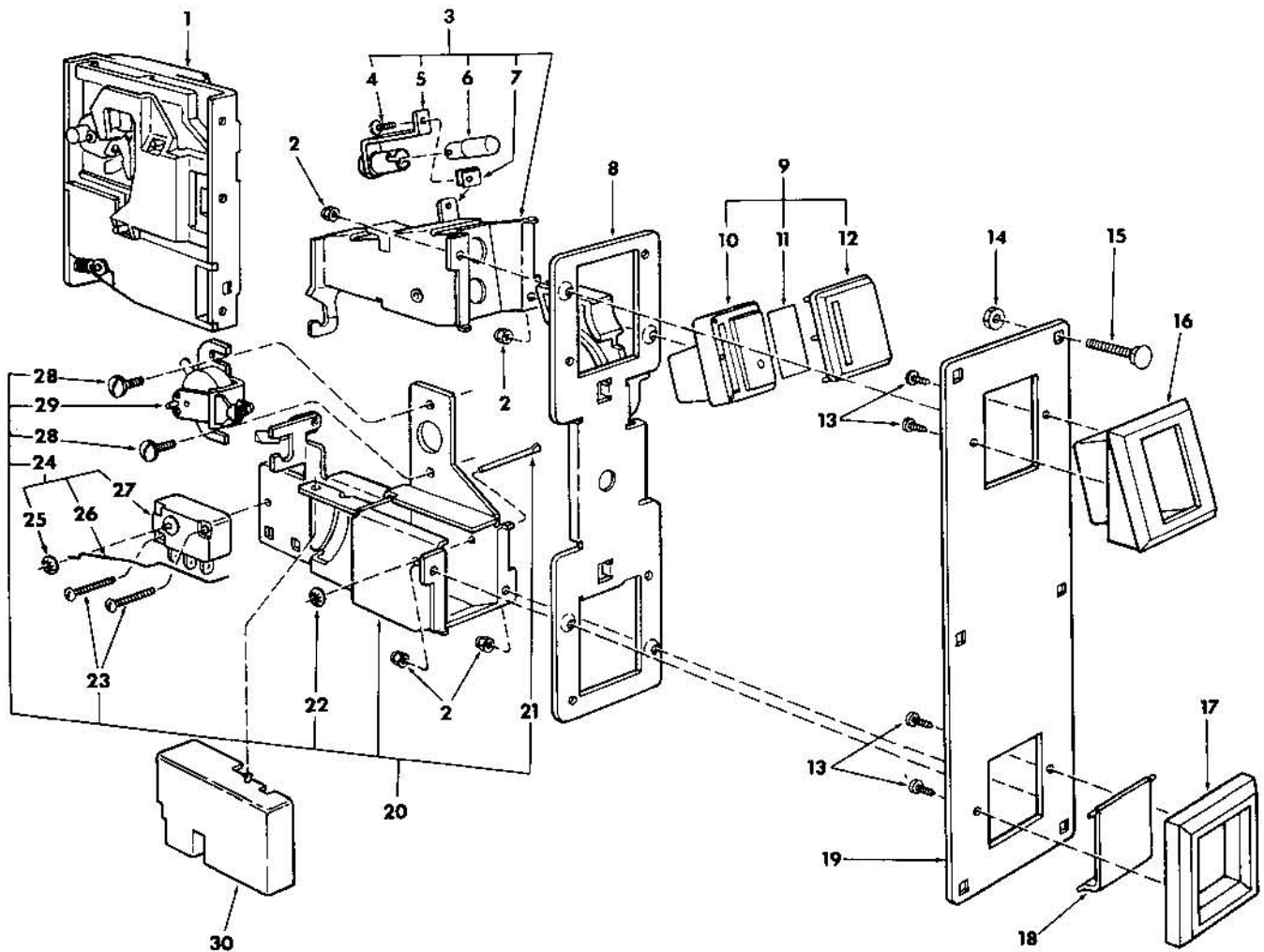

FIGURE 5

Index No.	Part No.	Description	Index No.	Part No.	Description
1	5301-10	25¢ Coin Acceptor	16	904588	Coin Inlet Housing
2	400-4	#4-40 Self Locking Nut	17	904590	Coin Return Cover
3	404351	Coin Inlet Chute Assembly	18	904599	Coin Return Door
4	110-4-6	4 x 3/8 Screw	19	404463	Frontplate Assembly, 3-1/8" x 9-1/4"
5	904717	Lamp Socket	20	404350	Coin Return Chute Assembly
6	904716	#47 Lamp (6.3 Volt)	21	905115	Bar
7	904712	Fastener	22	904936	Keeper
8	404464	Inner Panel/Lever Assembly	23	100-4-12	4-40 x 3/4 Screw
9	404348	Coin Return Button Assembly	24	404353	Switch & Wire Assembly
10	904591	Coin Return Button	25	900651	Retainer
11	904703	25¢ Price Decal	26	904710-1	Switch Wire-Silver
12	904589-2	Reject Cover Button (25¢)	27	904845	Switch
13	345-4-5	#4 x 5/16 Pan Head Screw	28	100-6-3	6-32 x 3/16 Screw
14	406-10	#10-24 Hex Nut (Mounting Hardware)	29	404354	12 Volt Crem Assembly
15	905022	#10-24 x 1-1/8 Carriage Bolt (Mounting Hardware)	30	904762	Switch Cover

2800-0 FRONT PLATE EXPLODED VIEW

(FIGURE 5)

PARTS LIST

<u>NO.</u>	<u>CENTURI P/N:</u>	<u>MANUFACTURING P/N:</u>	<u>DESCRIPTION:</u>
1.	50270144	5031-10	25¢ COIN ACCEPTOR
5.	50270169	904717	LAMP SOCKET
6.	50270170	904716	#47 LAMP (6.3 VOLT)
8.	50270172	404464	INNER PANEL/LEVER ASS'Y.
10.	50270145	904591	COIN RETURN BUTTON
11.	50270146	904703	25¢ PRICE DECAL
12.	50270147	904589-2	REJECT COVER BUTTON (25¢)
16.	50270149	904588	COIN INLET HOUSING
17.	50270157	904590	COIN RETURN BEZEL
18.	50270150	904599	COIN RETURN DOOR
19.	50270173	404463	FRONTPLATE ASS'Y. (3 ¹ / ₈ "x9 ¹ / ₄ "
21.	50270168	905115	BAR
25.	50270141	900651	RETAINER
26.	50270142	904710-1	SWITCH-WIRE, SILVER
27.	50130061	904845	SWITCH
29.	50270165	404354	12 VOLT C.R.E.M. ASS'Y.
30.	50270164	904762	SWITCH COVER

2800 SERIES COIN DOOR EXPLODED VIEW

25¢ U.S. COIN

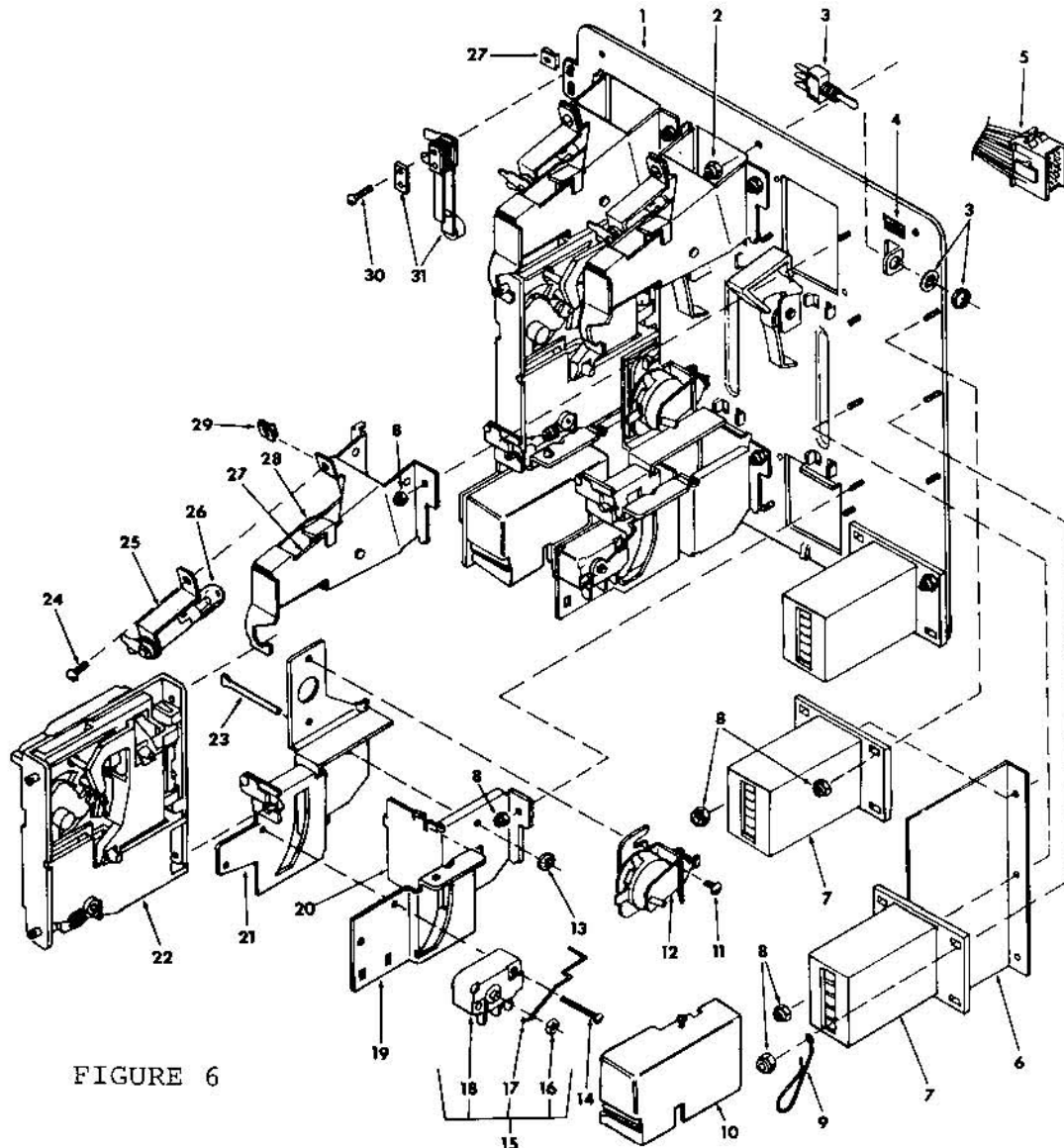

FIGURE 6

Index No.	Part No.	Description	Index No.	Part No.	Description
1	404429	Inner Panel With Levers Sub-Assembly	17	904710-1	Silver Switch Wire — for U.S. 25¢ Coin
2	400-8	Nut	18	904845	Switch
3	904782	Toggle Switch	19	904701	Coin Chute
4	904706	Test Switch Decal	20	904598	Coin Return Box
5		Custom Harness Assembly	21	404428	Switch and C.R.E.M. Coil Bracket Assembly
6	904822	Insulation	22	5301-10	25¢ Acceptor
7	404352	Coin Counter Assembly (6 Volt D.C.)	23	905115	Bar
8	400-4	Nut	24	110-4-6	Screw
9	904722	Wire Key Holder	25	904717	Miniature Bayonet-Base Lamp Socket
10	904762	Switch Cover	26	904716	#47 Lamp (6.3 Volt)
11	100-6-3	Screw	27	404418	Coin Inlet Chute Sub-Assembly
12	404354	C.R.E.M. Coil Assembly. 12 Volts D.C.	28	904594	Right Half of Coin Inlet Chute
13	904936	Keeper	29	904712	"U"-Type Fastener
14	100-4-12	Screw	30	116-4-8	Screw
15	404353	Coin Switch Assembly for U.S. 25¢ Coin	31	904704	Slam Switch Assembly
16	900651	Retainer			

2800 SERIES COIN DOOR EXPLODED VIEW

25¢ U.S. COIN

(FIGURE 6)

PARTS LIST

<u>NO.</u>	<u>CENTURI P/N:</u>	<u>MANUFACTURING P/N:</u>	<u>DESCRIPTION:</u>
1.	50270160	404429	INNER PANEL w/LEVERS SUBASS'Y.
3.	50130062	904782	TOGGLE SWITCH
4.	50270161	904706	TEST SWITCH DECAL
5.	364-62-1000A	-----	CUSTOM HARNESS ASS'Y.
6.	50270162	904822	INSULATION
7.	50270140	404352	COIN COUNTER ASS'Y.
9.	50270163	904722	WIRE KEY HOLDER
10.	50270164	904762	SWITCH COVER
12.	50270165	404354	C.R.E.M. COIL ASS'Y. (12 VOLT D.C.)
17.	50270142	904710-1	SILVER SWITCH WIRE- FOR 25¢ U.S. COIN
18.	50130061	904845	SWITCH
19.	50270143	904701	COIN CHUTE
20.	50270166	904598	COIN RETURN BOX
21.	50270167	404428	SWITCH & C.R.E.M. COIL BRACKET ASS'Y.
22.	50270144	5301-10	25¢ ACCEPTOR
23.	50270168	905115	BAR
25.	50270169	904717	MINIATURE BAYONET-BASE LAMP SOCKET
26.	50270170	904716	#47 LAMP (6.3 VOLTS)
27.	50270171	404418	COIN INLET CHUTE-SUBASS'Y.
31.	50130063	904707	SLAM SWITCH ASSEMBLY

2800 SERIES COIN DOOR EXPLODED VIEW

25¢ U.S. COIN

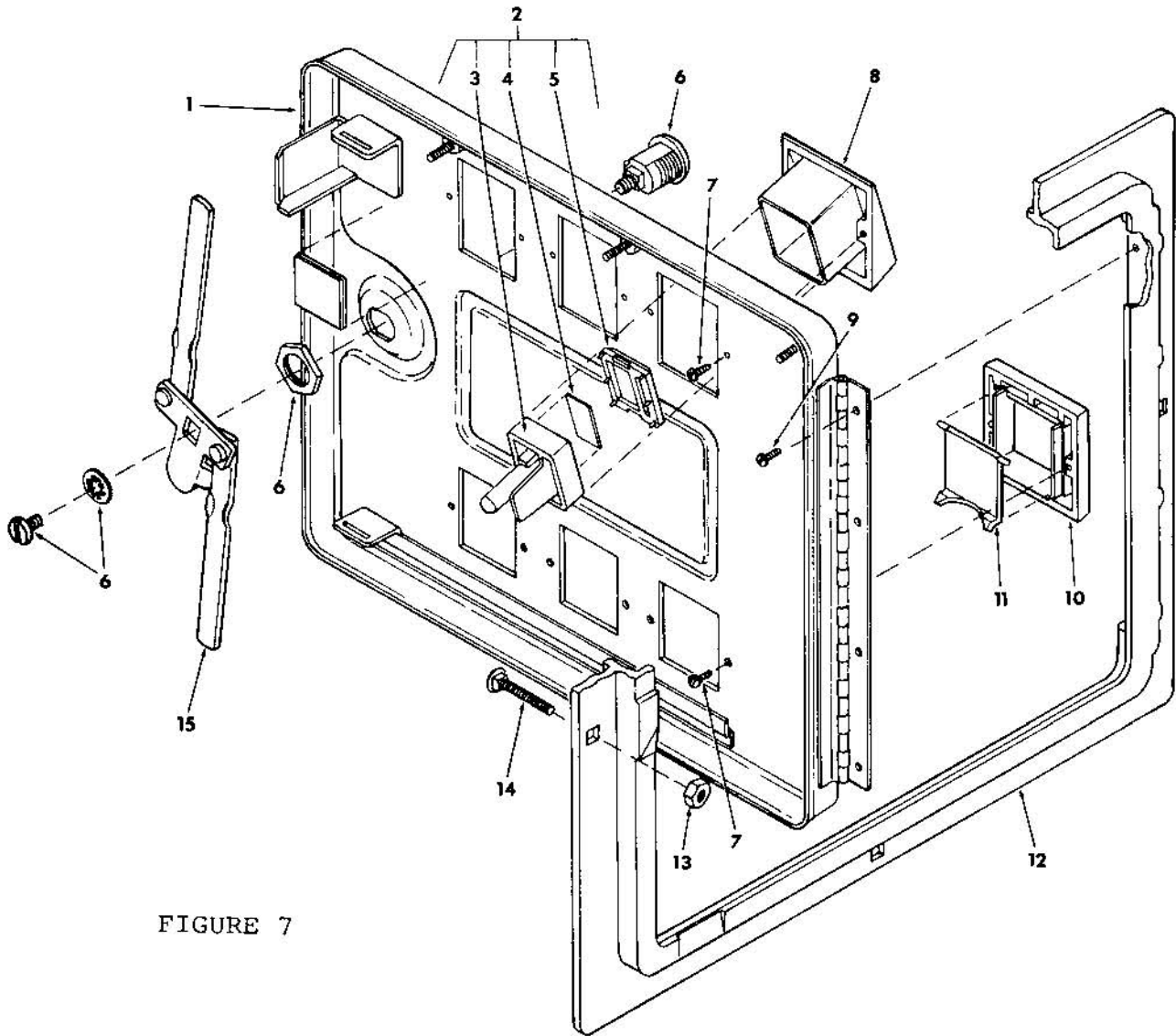

FIGURE 7

Index No.	Part No.	Description	Index No.	Part No.	Description
1	404341	Coin Door Only (2 Coin)	7	345-4-5	Screw
	404341-1	Coin Door Only (3 Coin)	8	904588	Coin Button Housing
2	404348-1	Coin Return Button Assembly for U.S. 25¢ Coin	9	325-4-4	Screw
3	904591	Coin Return Button	10	904590	Coin Return Bezel
4	904703	U.S. 25¢ Price Decal	11	904599	Coin Return Cover
5	904589-2	Coin Return Button Cover for U.S. 25¢ Coin	12	904581	Coin Door Frame, 11-5/8" x 13-3/8" Mounts in a 10-3/8" x 12-3/16" Opening
6	904707-1	Lock Assembly	13	406-416	Hex Nut
			14	904734	Carriage Bolt
			15	404357	Locking Arm Assembly

2800 SERIES COIN DOOR EXPLODED VIEW

25¢ U.S. COIN

(FIGURE 7)

PARTS LIST

<u>NO.</u>	<u>CENTURI P/N:</u>	<u>MANUFACTURING P/N:</u>	<u>DESCRIPTION:</u>
1.	50270152	404341	COIN DOOR ONLY (2 COIN)
2.	50270158	404348-1	COIN DOOR BUTTON ASS'Y. FOR U.S. 25¢ COIN
3.	50270145	904591	COIN RETURN BUTTON
4.	50270146	904703	U.S. 25¢ PRICE DECAL
5.	50270147	904589-2	COIN RETURN BUTTON COVER
6.	50270148	904707-1	LOCK ASSEMBLY w/KEYS
8.	50270149	904588	COIN BUTTON HOUSING (INLET HOUSING)
10.	50270157	904590	COIN RETURN BEZEL
11.	50270150	904599	COIN RETURN COVER
12.	50270151	904581	COIN DOOR FRAME (11 5/8"x13 3/8")
15.	50270159	404357	LOCKING ARM ASSEMBLY

PARTS LIST - SHINDENGEN POWER SUPPLY

<u>SYMBOL:</u>	<u>DESCRIPTION:</u>	<u>USAGE:</u>
T1	TRANSFORMER, SINGLE PHASE, 2A VA	1
L1	CHOKING COIL, 1.6mH, 1.5A	1
L2, L4	CHOKING COIL, SF-T8-50S-03	2
L3	CHOKING COIL, SF-HP-2A-03	1
D1	DIODE, V19G	1
D2	DIODE, V06C	1
D3, D6	DIODE, 1S1588	2
D4	DIODE, S15S3	1
D5, D7	DIODE, 5CH1M	2
D12, D13	DIODE, F113B	2
D14	DIODE, F113B	1
RF1	DIODE, S4VB40 (BRIDGE TYPE)	1
Q1	TRANSISTOR, 2SC2504	1
Q2	TRANSISTOR, 2SD467 (B)	1
Q3	TRANSISTOR, 2SC460 (B)	1
Q4	TRANSISTOR, 2SA673 (B)	1
IC1	INTEGRATED CIRCUIT, RM723DC or HA17723G-02	1
PC1	PHOTO COUPLER, PS2001	1
R1	RESISTOR, 2 WATT, 18 OHM	1
R8, R9	RESISTOR, 2 WATT, 47K OHM	2
R3, 1-4	RESISTOR, 2 WATT, 15 OHM	4
R4	RESISTOR, 1 WATT, 56 OHM	1
R12	RESISTOR, 1 WATT, 100 OHM	1
R28	RESISTOR, 1 WATT, 470 OHM	1
R7	RESISTOR, 1 WATT, 0.56 OHM	1
R26	RESISTOR, 1 WATT, 0.82 OHM	1
R23	RESISTOR, 1/4 WATT, 22 OHM	1
R10	RESISTOR, 1/4 WATT, 33 OHM	1
R27	RESISTOR, 1/4 WATT, 68 OHM	1
R2	RESISTOR, 1/4 WATT, 330-470 OHM	1
R22	RESISTOR, 1/4 WATT, 220 OHM	1
R21	RESISTOR, 1/4 WATT, 270 OHM	1
R6	RESISTOR, 1/4 WATT, 330 OHM	1
R11	RESISTOR, 1/4 WATT, 68 OHM	1
R20	RESISTOR, 1/4 WATT, 470 OHM	1
R17	RESISTOR, 1/4 WATT, 680 OHM	1
R19	RESISTOR, 1/4 WATT, 800 OHM	1
R18	RESISTOR, 1/4 WATT, 1.2K OHM	1
R5	RESISTOR, 1/4 WATT, 10K OHM	1
R16	RESISTOR, 1/4 WATT, 220K OHM	1
R29	RESISTOR, 3 WATT, 27 OHM	1
R39	RESISTOR, 1/4 WATT, 4.7K OHM	1
R38	RESISTOR, 1/4 WATT, 5.6K OHM	1
R24	RESISTOR, 1/4 WATT, 330 OHM	1
R25	RESISTOR, 1/4 WATT, 150 OHM	1
RV1	VARIABLE RESISTOR, RJ-6P501	1

PARTS LIST - SHINDENGEN POWER SUPPLY

<u>SYMBOL:</u>	<u>DESCRIPTION:</u>	<u>USAGE:</u>
C1, C2	CAPACITOR, ECK-DAL102E	2
C3-1,-2	CAPACITOR, 160VSN100	2
C9, C10	CAPACITOR, SM10VB-2200	2
C11, C23	CAPACITOR, SM10VB-2200	2
C12, C13, C15	CAPACITOR, SL25VB-10	3
C27	CAPACITOR, SL25VB-10	1
C18, C19, C20	CAPACITOR, SM35VB-1000	3
C26	CAPACITOR, SM35VB-1000	1
C21, C22, C25	CAPACITOR, SM16VB-1000	3
C5	CAPACITOR, DMY21H472K	1
C6	CAPACITOR, DMY21H104K	1
C14, C16	CAPACITOR, DMY21H222K	2
C4	CAPACITOR, CM20XC511K5	1
C8	CAPACITOR, MDD22G473K	1
C5-2	CAPACITOR, DMY21H222K	1
F1, F2	ENCLOSED TYPE FUSE, 3A	2

PERIPHERAL INTERFACE BOARD A-30

<u>NO.</u>	<u>PART NUMBER:</u>	<u>DESCRIPTION:</u>	<u>USAGE:</u>
1.	50020005	MPS 6531 NPN SIGNAL TRANSISTOR	1
2.	50020065	TIP 120 NPN POWER TRANSISTOR	1
3.	50030014	270 OHM, 1/4W., 5% RESISTOR	2
4.	50030097	2.7K OHM, 1/4W., 5% RESISTOR	1
5.	50040010	0.1mfd, 16V., CERAMIC DISC CAPACITOR	2
6.	50060055	100mfd, 16V., ELECTROLYTIC CAPACITOR	1
7.	50230001	3 AG., 1 AMP, NORMAL BLOW FUSE	1
8.	50230014	3 AG., P.C MOUNT FUSE CLIP	2
9.	50150313	4 CKT., P.C. WAFER, MOLEX	1
10.	50150310	10 CKT., P.C. WAFER, MOLEX	1
11.	50150312	9 CKT., P.C. WAFER, MOLEX	3
12.	50150177	20 PIN FLAT CABLE HEADER, STRAIGHT w/EJECTOR	1
13.	50100007	1N40001 SILICON 1AMP DIODE	1
14.	50100014	1N914 SIGNAL DIODE	32
15.	50210197	P.C. BOARD, A-30	1

VIDEO INTERFACE BOARD A-20

<u>NO.</u>	<u>PART NUMBER:</u>	<u>DESCRIPTION:</u>	<u>USAGE:</u>
1.	50010002LS	74LS00 I.C.	2
2.	50010004LS	74LS02 I.C.	2
3.	50010005LS	74LS04 I.C.	3
4.	50010007LS	74LS10 I.C.	2
5.	50010008LS	74LS20 I.C.	2
6.	50010019LS	74LS74 I.C.	6
7.	50010024LS	74LS93 I.C.	4
8.	50010028LS	74LS153 I.C.	5
9.	50010045LS	74LS157 I.C.	2
10.	50010059LS	74LS165 I.C.	6
11.	50010105LS	74LS32 I.C.	1
12.	50010194LS	74LS191 I.C.	5
13.	50010014	7442 I.C.	3
14.	50010191	MK4027-4, 350ns I.C.	48
15.	50030051	1K OHM, 1/4W., 5% RESISTOR	3
16.	50030095	330 OHM, 1/4W., 5% RESISTOR	2
17.	50030206	180 OHM, 1/4W., 5% RESISTOR	3
18.	50040010	.1mfd, 16V., CERAMIC DISC CAPACITOR	33
19.	50040027	.01mfd, 16V., CERAMIC DISC CAPACITOR	1
20.	50040053	100pfd, 25V., CERAMIC DISC CAPACITOR	10
21.	50060055	100mfd, 16V., AXIAL ELECTROLYTIC CAPACITOR	3
22.	50040066	470pfd, 16V., CERAMIC DISC CAPACITOR	4
23.	50150111	16 PIN SOLDER TRAIL SOCKET, LOW PROF.	48
24.	50150178	26 PIN FLAT CABLE P.C.B. HEAD w/EJECTOR	1
25.	50150310	10 CKT., P.C. WAFER, MOLEX	1
26.	50150314	12 CKT., P.C. WAFER, MOLEX	1
27.	50070009	11.6688 MH ₂ CRYSTAL	1
28.	50210195	VIDEO INTERFACE BOARD	1

AUDIO COMPUTER BOARD A-25

NO.	PART NUMBER:	DESCRIPTION:	USAGE:
1.	50010004LS	74LS02 I.C.	1
2.	50010005LS	74LS04 I.C.	1
3.	50010014LS	74LS42 I.C.	1
4.	50010019LS	74LS74 I.C.	1
5.	50010172	6502 I.C., C.P.U.	1
6.	50010177	AY3-8910 I.C.	1
7.	50010171	2716 I.C., EPROM	1
8.	50010206	6532 I.C.	1
9.	50010054	LM380N I.C.	1
10.	50030010	470 OHM, 1/4W., 5% RESISTOR	2
11.	50030146	15K, 1/4W., 5% RESISTOR	2
12.	50030112	3.3K, 1/4W., 5% RESISTOR	3
13.	50030092	1 MEG., 1/4W., 5% RESISTOR	1
14.	50030051	1K, 1/4W., 5% RESISTOR	2
15.	50030154	2.7 OHM, 1/4W., 5% RESISTOR	1
16.	50030150	47K, 1/4W., 5% RESISTOR	1
17.	50030063	10K, 1/4W., 5% RESISTOR	1
18.	50040010	0.1mfd, 16V., CERAMIC DISC CAPACITOR	16
19.	50040011	.001mfd, 16V., CERAMIC DISC CAPACITOR	1
20.	50040056	.05mfd, 16V., CERAMIC DISC CAPACITOR	1
21.	50040085	22pfd, 16V., CERAMIC DISC CAPACITOR	1
22.	50060060	10mfd, 16V., AXIAL ELECTROLYTIC CAPACITOR	1
23.	50060055	100mfd, 16V., AXIAL ELECTROLYTIC CAPACITOR	3
24.	50060090	2.2mfd, 16V., AXIAL ELECTROLYTIC CAPACITOR	1
25.	50060058	2200mfd, 16V., ELECTROLYTIC CAPACITOR	1
26.	50130034	8 POSITION DIP SWITCH (SPST)	2
27.	50150061	24 PIN SOLDER TRAIL SOCKET, LOW PROF.	1
28.	50150060	40 PIN SOLDER TRAIL SOCKET, LOW PROF.	3
29.	50150179	34 PIN FLAT CABLE HEADER w/EJECTOR	1
30.	50230001	3 AG., 1 AMP FUSE, NORMAL BLOW	1
31.	50230014	3 AG., MOUNT FUSE CLIP	2
32.	50150311	3 CKT., P.C. WAFER, MOLEX	1
33.	50150310	10 CKT., P.C. WAFER, MOLEX	1
34.	50070005	3.579 MHZ CRYSTAL	1
35.	50090015	14 PIN DIP HEAT SINK, V7-1, STAVER	1
36.	50120005	100K, 1/4W., TRIMMER POT	1
37.	50210196	AUDIO COMPUTER BOARD, A-25	1

MICRO COMPUTER BOARD, REV. CPARTS LIST

<u>NO.</u>	<u>PART NUMBER</u>	<u>DESCRIPTION:</u>	<u>USAGE:</u>
1.	50010002LS	74LS00 I.C.	1
2.	50010005LS	74LS04 I.C.	4
3.	50010019LS	74LS74 I.C.	2
4.	50010273LS	74LS244 I.C.	2
5.	50010195LS	74LS367 I.C.	1
6.	50010248LS	74LS138 I.C.	2
7.	50010045LS	74LS157 I.C.	1
8.	50010035LS	74LS161 I.C.	1
9.	50010172	6502 I.C., CPU	1
10.	50010173	6522 I.C.	3
11.	50010322	2532 I.C., EPROM 500ns or LESS	6
12.	50030007	100K., 1/4W., 5% RESISTOR	1
13.	50030010	470 OHM, 1/4W., 5% RESISTOR	2
14.	50030063	10K., 1/4W., 5% RESISTOR	3
15.	50030112	3.3K, 1/4W., 5% RESISTOR	3
16.	50040010	.1mfd., 16V., CERAMIC DISC CAPACITOR	14
17.	50040011	.001mfd., 16V., CERAMIC DISC CAPACITOR	9
18.	50040056	.05mfd., 16V., CERAMIC DISC CAPACITOR	1
19.	50060055	100mfd., 16V., AXIAL ELECTROLYTIC CAPACITOR	1
20.	50060124	1.0mfd., 16V., AXIAL ELECTROLYTIC CAPACITOR	1
21.	50070005	3.579MH _z , CRYSTAL w/LEAD WIRES	1
22.	50130034	8 POSITION DIP SWITCH (SPDT)	3
23.	50150061	24 PIN SOLDER TRAIL SOCKET, LOW PROF.	8
24.	50150060	40 PIN SOLDER TRAIL SOCKET, LOW PROF.	4
25.	50150112	18 PIN SOLDER TRAIL SOCKET, LOW PROF.	4
26.	50100014	1N914 SIGNAL DIODE	1
27.	50150177	20 PIN FLAT CABLE w/EJECTOR	1
28.	50150178	26 PIN FLAT CABLE w/EJECTOR	1
29.	50150179	34 PIN FLAT CABLE w/EJECTOR	1
30.	50150310	10CKT. P.C. WAFER, MOLEX	1
31.	50010310	2114 RAM	2
32.	50210194C	MICRO COMPUTER BOARD, REV. C	1
33.	374-10-0300	EPROM LABELS	6

CONTROL PANEL

10	8	10150007	#10-24 KEPS NUT
9	1	10110022	#10-24x3/4 CARRIAGE BOLT BLACK OXIDE
8	7	50130049	RED BUTTON ASSY
7	7	50130050	PAL NUT
6	7	50130047	SWITCH & BRACKET
5	1	361-10-0600	HINGE CONTROL DECK
4	6	10110029	#10-24x1/2 CARRIAGE BOLT, BLACK OXIDE
3	1	374-03-0100	CONTROL PANEL
2	1	374-06-0400	CONTROL PANEL OVERLAY
1	4	50130048	WHITE BUTTON ASSY
ITEM QTY		PART NR DESCRIPTION	
BILL OF MATERIALS			

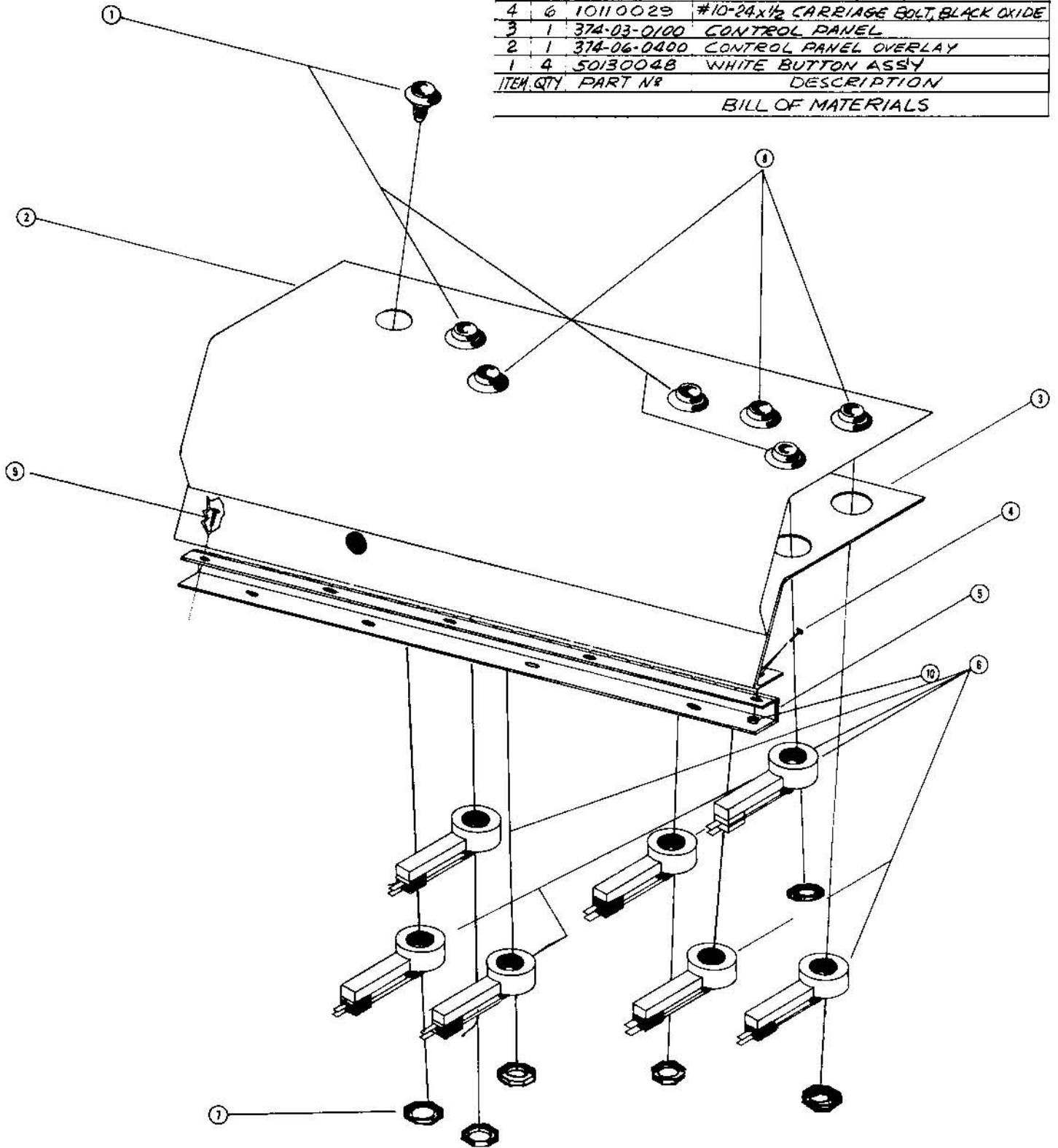
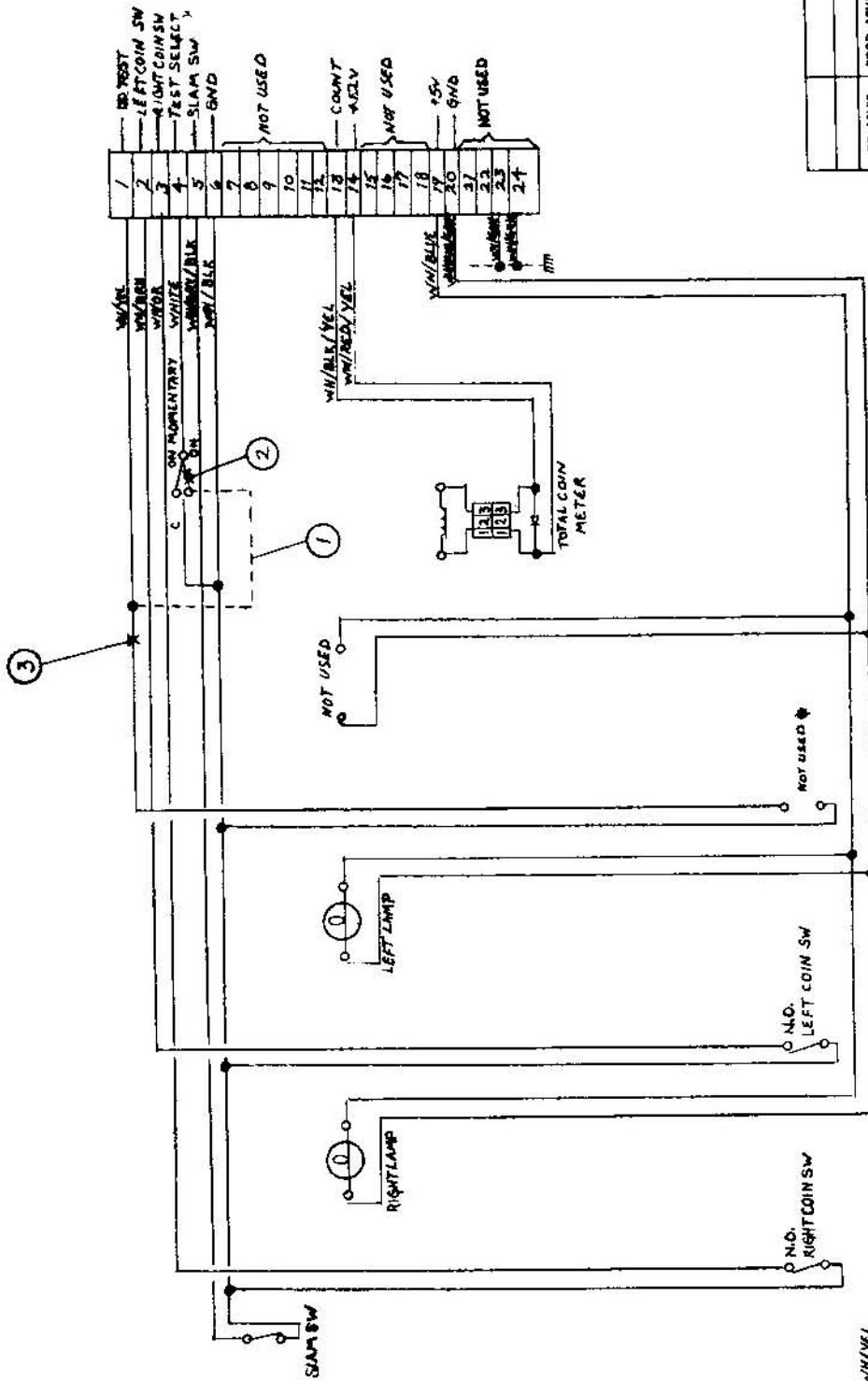

FIG. 3



- NOTE:
- ① INDICATES W/VEL WIRE CONN TO ON SIDE OF TEST SW.
 - ② INDICATES CUT ON WHITE WIRE TO ON SIDE OF TEST SW.
 - ③ INDICATES CUT AND REMOVAL OF W/VEL WIRE FROM POINT X TO NOT USED.

OC. APVD	PROD. APVD	QTY.	ASSEMBLY NO.
CONFORM			
MIALEAH, FLORIDA 33014			
NAME GAMMA II COIN DOOR, MODIFIED			
MATERIALS SCALE 3/4" = 1'-0"			
DATE 8-27-81			
REV. NO. 34-10-0400			
REV.			

TOLERANCES		Unless Otherwise Specified	
FRACTIONS	± 1/32		
DECIMALS SPL	± 0.05		
DECIMALS SPL	± 0.06		
HOLE	± 0.01		
ANGLES	± 1/2°		
SMT. MET BENDS	± 2°		

REV. LET.	EDN NO.	REVISION	BY

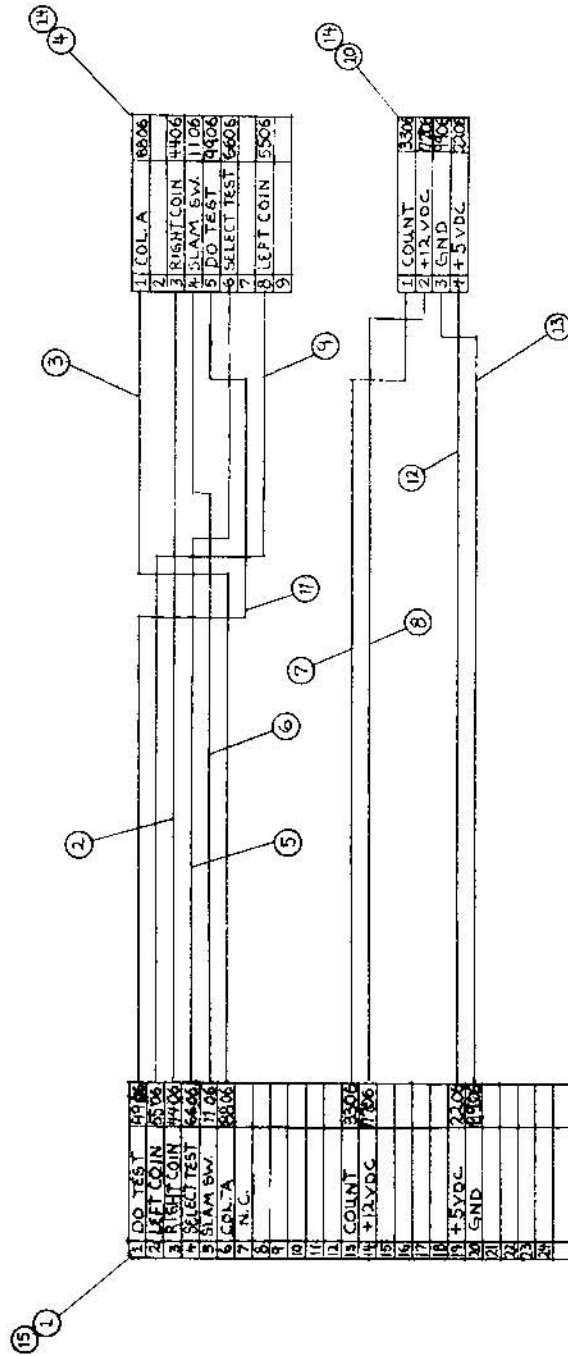

ITEM	QTY	PART NO.	DESCRIPTION
15	10	50150281	AMP FEMALE PINS
14	10	50150274	CRIMP TERMINAL STRAIN (COLLECT)
13	2W	50179906	BLACK WIRE
12	2W	50172206	RED WIRE
11	2W	50178000	ORANGE WIRE
10	1	50150270	AMP FEMALE HOUSING (WIRE)
9	1	50150270	AMP FEMALE HOUSING (WIRE)
8	2W	50172308	GREEN WIRE
7	2W	50177006	VIOLET WIRE
6	2W	50173308	ORANGE WIRE
5	2W	50175606	BROWN WIRE
4	1	50150309	AMP FEMALE HOUSING (WIRE)
3	2W	50178906	GRAY WIRE
2	2W	50178906	GRAY WIRE
1	1	50150288	AMP FEMALE HOUSING (WIRE)

NOTE: ALL WIRE IS #22 AWG

REV.	ECH	REV.	ECH	REV.	ECH
TOLERANCES UNLESS OTHERWISE SPECIFIED FRACTIONS 1/16 DECIMALS 2 PL 0.05 DECIMALS 3 PL 0.002 HOLE .001 HOLE .001			NAME: COIN DOOR HARNESS PART NO.: MEAT TREAT MODEL: MEAT TREAT DATE: 11/79 CITY: TAMPA STATE: FL ZIP: 33618 REGION: 33		
DC. APP'D. PROD. APP'D. CITY. ASSEMBLY NO.			MANUFACTURED BY: CARLTON MANUFACTURED IN: HALLEAH, FLORIDA 32914		

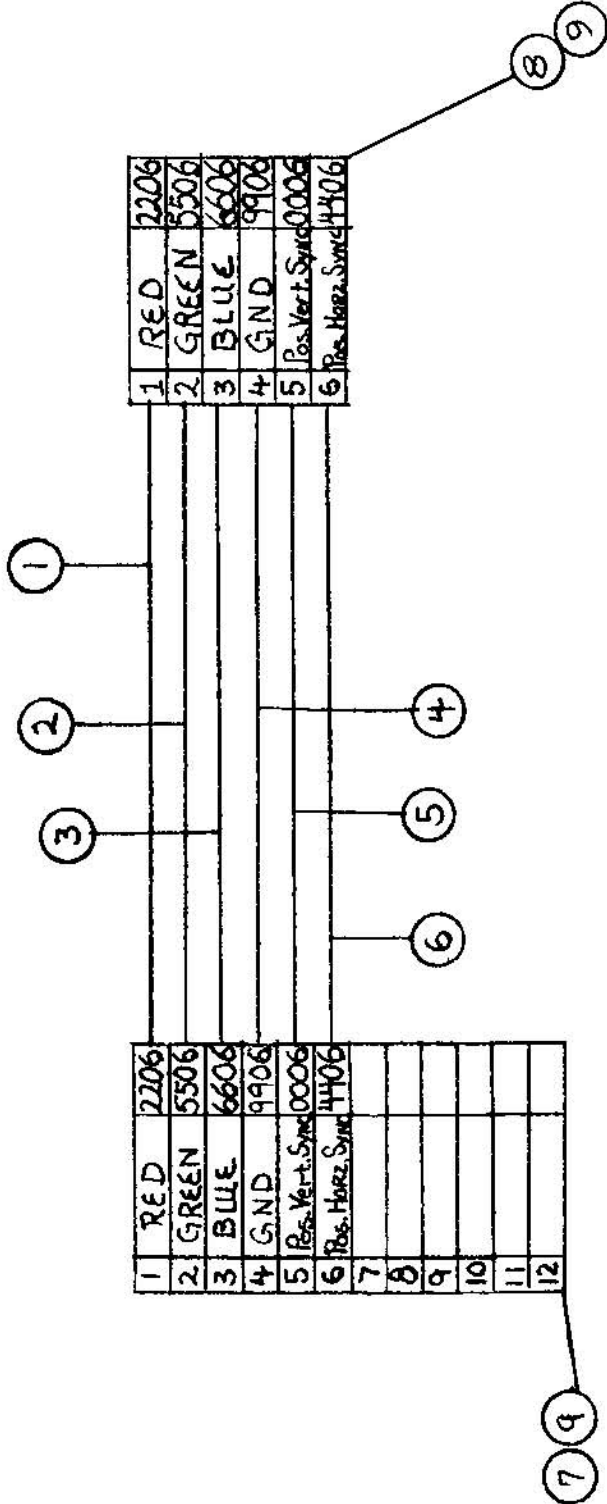

1	RED	2206
2	GREEN	5506
3	BLUE	6606
4	GND	9906
5	Pos. Vert. Synd	0006
6	Pos. Horiz. Synd	4406

1	RED	2206
2	GREEN	5506
3	BLUE	6606
4	GND	9906
5	Pos. Vert. Synd	0006
6	Pos. Horiz. Synd	4406
7		
8		
9		
10		
11		
12		

ITEM	QTY	PART NO.	DESCRIPTION
9	12	50150274	CRIMP TERMINALS MOLEX
8	1	50150303	CKT. HOUSING MOLEX
7	1	50150272	2CKT. HOUSING MOLEX
6	34	50174406	YELLOW WIRE #22 AWG
5	34	50170006	WHITE WIRE #22 AWG
4	34	50179906	BLACK WIRE #22 AWG
3	34	50176606	BLUE WIRE #22 AWG
2	34	50175506	GREEN WIRE #22 AWG
1	34	50172206	RED WIRE #22 AWG

TOLERANCES		
Unless Otherwise Specified		
FRACTIONS	± 1/32	
DECIMALS 2 PL	± .015	
DECIMALS 3 PL	± .005	
HOLES	± .003	
ANGLES	± .001	
SHT. MET BENDS	± .1/2	
ECN NO.	REVISION	BY

OC. APVD	PROD. APVD	QTY.	ASSEMBLY NO

centuri HIALEAH, FLORIDA 33014

NAME: ELECTRO HOME WELLS GARDNER MONITOR SIGNAL HARNESS

MATL'S: HEAT TREAT. FINISH

DATE: 10-1-81

SCALE: 3/4

PART NO: 374-12-0300

REV.:

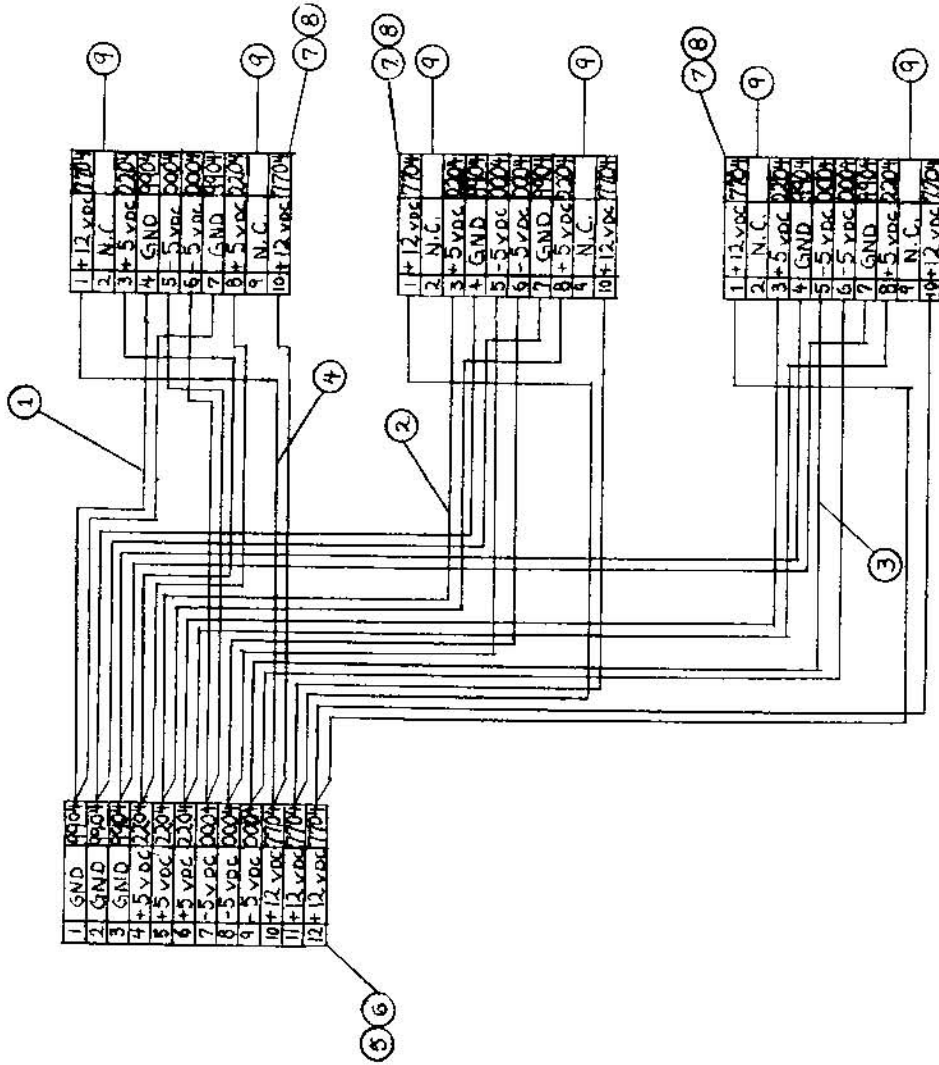

QTY	PART NO.	DESCRIPTION
9	50150273	MOLEX POLARIZING KEY
8	50150274	CRIMP TERMINALS MOLEX CHINA
7	50150277	10 CKT. FEMALE HOUSING MOLEX
5	50150277	10 CKT. FEMALE HOUSING MOLEX
5	50150261	MALE PINS MOLEX REEL
4	5017704	12 PIN MOLEX PLUG
3	5017604	VIOLET WIRE
2	5017304	RED WIRE
1	5017304	BLACK WIRE
1/2 EA		

NOTE: ALL WIRE IS #18 AWG

OC. APVD	PROD. APVD	QTY.	ASSEMBLY NO.
		1	374-01-0200
carton			
NAME: HIALEAH, FLORIDA 32014			
P.C.B. POWER HARNESS			
MATERIALS: HEAT TREAT.			
DATE: 7/4	SCALE: 1/2"	PART NO.:	REV.
3A-B	8-27-81	374-12-0600	

TOLERANCES	
UNLESS OTHERWISE SPECIFIED	
FRACTIONS	± 1/32
DECIMALS 3 PL	± .015
DECIMALS 2 PL	± .008
HOLES	± .001
ANGLES	± 1/2°
RHT. MET BENDS	± 2°

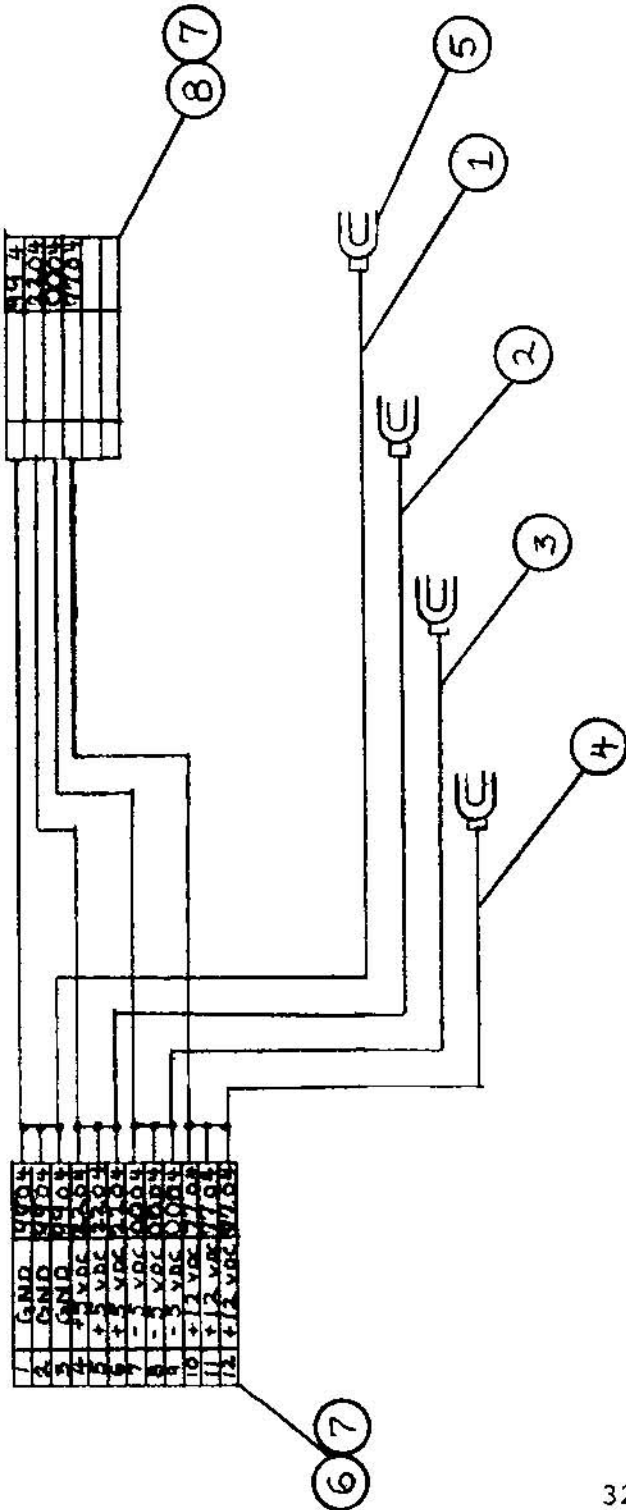

NOTE: ALL WIRE IS #18 AWG

ITEM	QTY	PART N°	DESCRIPTION
8	1	50150262	6 PIN MOLEX RECP.
7	16	50150278	FEMALE PINS MOLEX
6	1	50150263	12 PIN MOLEX RECP.
5	4	50150293	INSULATED OPEN LUG
4	27	50177704	VIOLET WIRE
3	27	50170004	WHITE WIRE
2	27	50172204	RED WIRE
1	27	50179904	BLACK WIRE

+12
-5
+5
GND

OC. APV'D	PROG. APV'D	QTY.	ASSEMBLY NO

Continuum HIALEAH, FLORIDA 33014	
NAME D.C. OUTPUT POWER HARNESS	
MATL'S HEAT TREAT. FINISH	
DWN. JAB	DATE 8-2781
SCALE 374-12-0200	PART NO. 374-12-0200
REV. LET.	REV.

TOLERANCES	
Unless Otherwise Specified	
FRACTIONS	± 1/32
DECIMALS 2 PL	± .015
DECIMALS 3 PL	± .005
HOLES	+ .003
ANGLES	- .001
SHT. MET BENDS	± 1/2°

REVISION BY

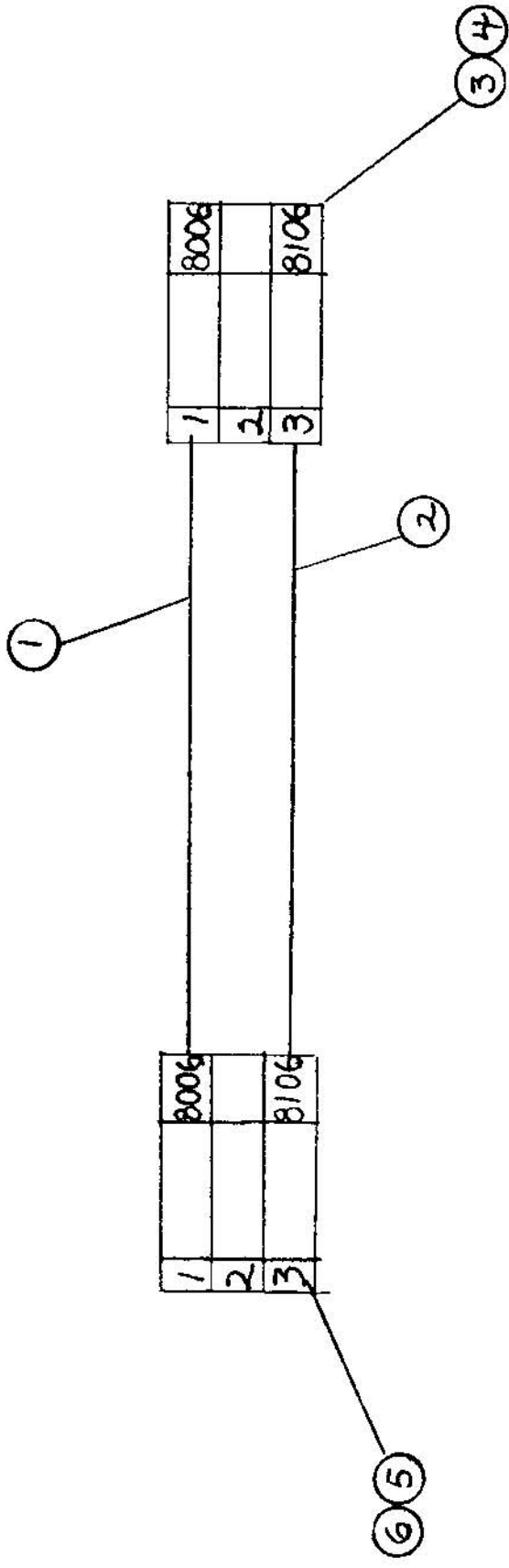

1	8006
2	
3	8106

1	8006
2	
3	8106

ITEM	QTY	PART NO.	DESCRIPTION	TOLERANCES	
				Unless Otherwise Specified	
6	2	50150228	FEMALE PINS MOLEX, REEL	FRACTIONS	± 1/32
5	1	50150231	3 PIN MOLEX RECEPTACLE	DECIMALS 2 PL	± .015
4	2	50150274	CRIMP TERMINAL MOLEX	DECIMALS 3 PL	± .005
3	1	50150301	3 PIN FEMALE HOUSING MOLEX	HOLES	± .003
2	85"	50178106	GRAY Y/BROWN STRIPE WIRE	ANGLES	- .001
1	85"	50178006	GRAY Y/BROWN STRIPE WIRE	SHT. MET BENDS	± 1/2"

NOTE: ALL WIRE IS #22 AWG

OC. APV'D	PROD. APV'D	QTY.	ASSEMBLY NO

		HIALEAH, FLORIDA 33014	
		NAME SPEAKER OUTPUT HARNESS	
MATERIALS		HEAT TREAT. FINISH	
REV. LET.	ECN NO.	REVISION	BY
DATE 8-27-81		SCALE	PART NO. 374-12-0400
DWN SAB			REV.

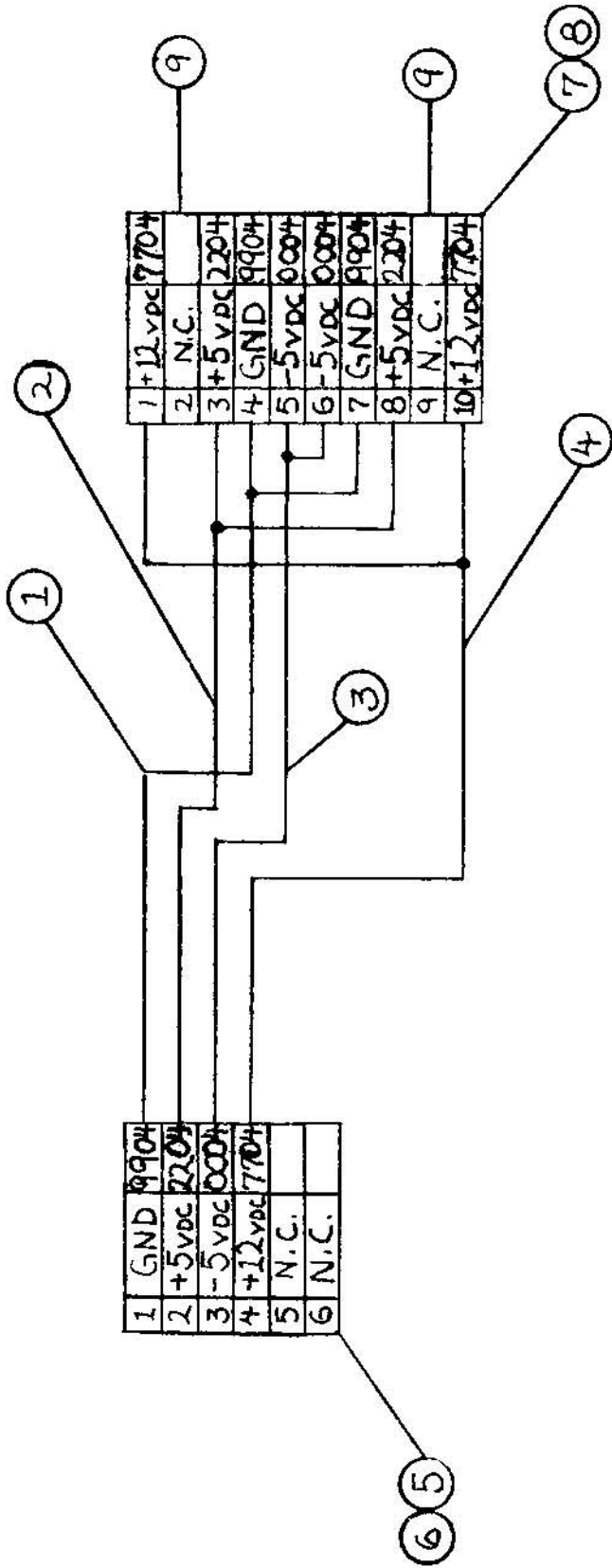

NOTE: ALL WIRE IS #18 AWG

ITEM	QTY	PART NO	DESCRIPTION
9	2	50150273	MOLEX POLARIZING KEY
8	8	50150274	CRIMP TERMINALS CHAIN
7	1	50150271	10 CKT. FEMALE HOUSING/MOLEX
6	4	50150277	MALE PINS/MOLEX REEL
5	1	50150260	6 PIN MOLEX PLING
4	32"	50177704	VIOLET WIRE
3	32"	50170004	WHITE WIRE
2	32"	50172204	RED WIRE
1	32"	50179904	BLACK WIRE

TOLERANCES		Unless Otherwise Specified	
FRACTIONS	±	1/32	
DECIMALS 2 PL	±	.015	
DECIMALS 3 PL	±	.005	
HOLES	+	.003	
ANGLES	-	.001	
SHT. MET BENDS	±	1/2°	2'

centuri		HIALEAH, FLORIDA 33014	
NAME PERIPHERAL POWER HARNESS			
MATERIALS HEAT TREAT. FINISH			
DWN. 3AB	DATE 8-27-81	SCALE	PART NO. 374-12-0700
REV. LET.	REVISION	BY	REV.



TOP VIEW

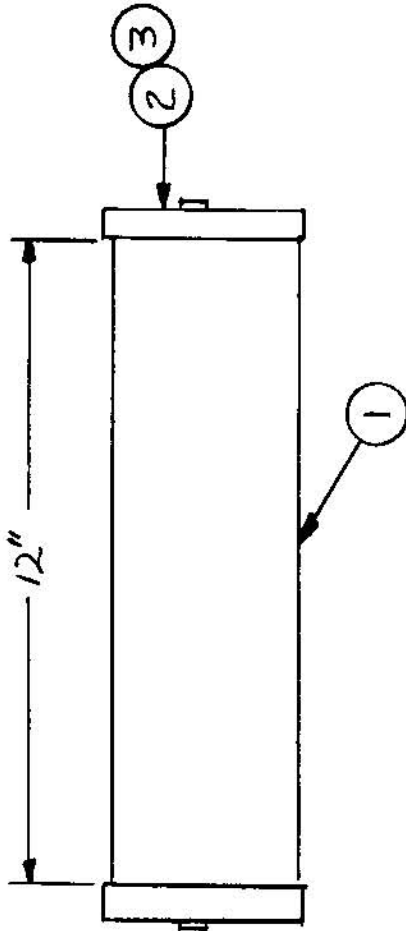

FRONT VIEW

3	2	50150148	34 PIN STRAIN RELIEF
2	2	50150124	34 PIN FLAT CABLE CONN.
1	16"	50150025	34 PIN FLAT CABLE
ITEM	QTY	PART NO	DESCRIPTION

BILL OF MATERIALS

OC. APV'D	PROD. APV'D	QTY.	ASSEMBLY NO

		MIALEAH, FLORIDA 33014	
		NAME AUDIO Bd. FLAT CABLE HARNESS	
MATERIALS		HEAT TREAT. FINISH	
DWN AAN	DATE 12-7-69	SCALE 3/4"	PART NO 172-17-1111
REV. LET.	ECN NO.	REVISION	BY

TOLERANCES	
Unless Otherwise Specified	
FRACTIONS	± 1/32
DECIMALS 2 PL	± .015
DECIMALS 3 PL	± .005
HOLES	+ .003
ANGLES	- .001
SHT. MET BENDS	± 1/2°



TOP VIEW

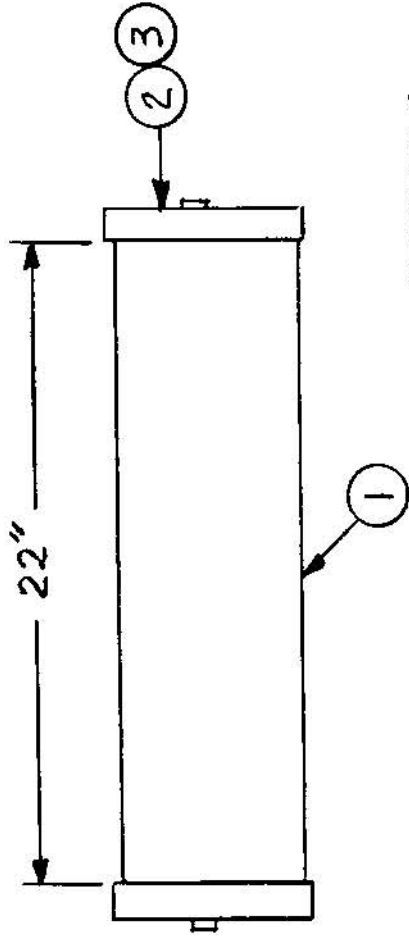

FRONT VIEW

3	2	50150146	20 PIN STRAIN RELIEF
2	2	50150122	20 PIN FLAT CABLE CONN.
1	22	50170023	20 PIN FLAT CABLE
ITEM	QTY	PART NO	DESCRIPTION

BILL OF MATERIALS

OC. APVD	PROD. APVD	QTY.	ASSEMBLY NO

		MIALEAH, FLORIDA 33014	
NAME		PERIPHERAL BD. FLAT CABLE HARNESS	
MATERIALS		HEAT TREAT. FINISH	
DOWN	DATE	SCALE	PART NO.
AAN	10-17-81	X	374-12-0900
REV. LET.	ECN NO.	REVISION	BY

TOLERANCES	
Unless Otherwise Specified	
FRACTIONS	± 1/32
DECIMALS 2 PL	± .015
DECIMALS 3 PL	± .005
HOLES	± .003
ANGLES	± .001
SHT. MET BENDS	± 1/2°



TOP VIEW

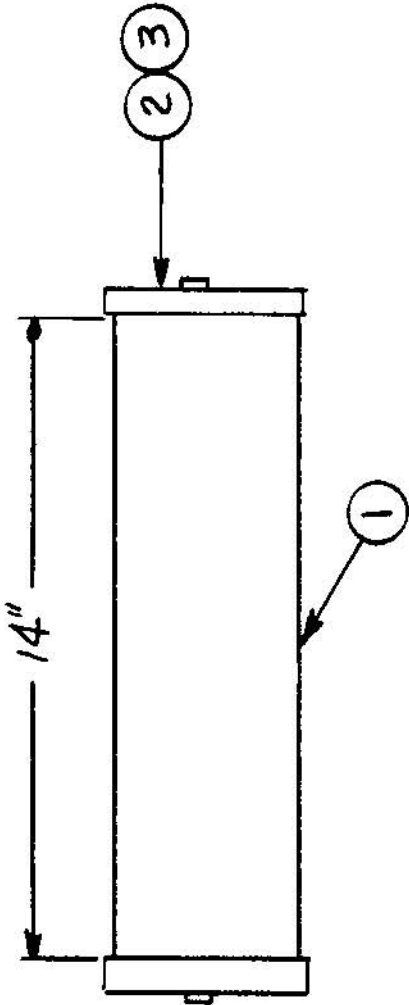

FRONT VIEW

ITEM	QTY	PART NO	DESCRIPTION
3	2	50150147	26 PIN STRAIN RELIEF
2	2	50150123	26 PIN CONN
1	14"	50170024	26 COND. CABLE
BILL OF MATERIALS			

OC. APVD	PROD. APVD	QTY.	ASSEMBLY NO

centuri MIALEAM, FLORIDA 33014	
NAME VIDEO FLAT CABLE HARNESS	
MAT'L'S.	HEAT TREAT. FINISH
DWN. AAN	DATE 8-26-81
REV. LET.	SCALE 3/4
ECN NO.	PART NO. 374-12-1000
REVISION	BY

23	50	50170008	4" wire ties
22	50	50151104	Brown wire #18 AWG
21	50	50157004	Violet stripe #18 AWG
20	50	50176604	Blue wire #18 AWG
19	86	50179204	White stripe #18 AWG
18	50	50175904	Green stripe #18 AWG
17	44	50175404	Green stripe #18 AWG
16	16	50175004	Green stripe #18 AWG
15	132	50170904	Black stripe #18 AWG
14	47	50179004	White/Green #18 AWG
13	86	50177704	Violet wire #18 AWG
12	67	50175504	Green wire #18 AWG
11	39	50170004	White wire #18 AWG
10	38	50179904	Black wire #18 AWG
9	2	50150231	3 PIN RECEPT W/EAR # 2000
8	9	50150278	4 PIN RECEPT W/EAR # 2000
7	16	50150277	4 PIN RECEPT W/EAR # 2000
6	3	50150096	WILLIAMS # RS-42162 B
5	3	50150105	KING LUG # R41238 B
4			HOLLANDS # R41238 B
3	1	50150260	6 PIN PLUG W/EAR # 2000
2	1	50150262	6 PIN RECEPT W/EAR # 2000
1	1	50150261	6 PIN PLUG W/EAR # 2000
			Bill of Materials

QC. APVD	PROD. APVD	QTY.	ASSEMBLY NO.
contun			
HIALEAH, FLORIDA 33014			
NAME Cabinet Power Harness			
MATERIALS HEAT TREAT. FINISH			
REV. LET.	ECN NO.	SCALE	PART NO. REV.
A	370-24	5-6-81	370-12-0200 A
APPROVED	DATE	SCALE	PART NO. REV.
JTS	5-6-81	5-6-81	370-12-0200 A

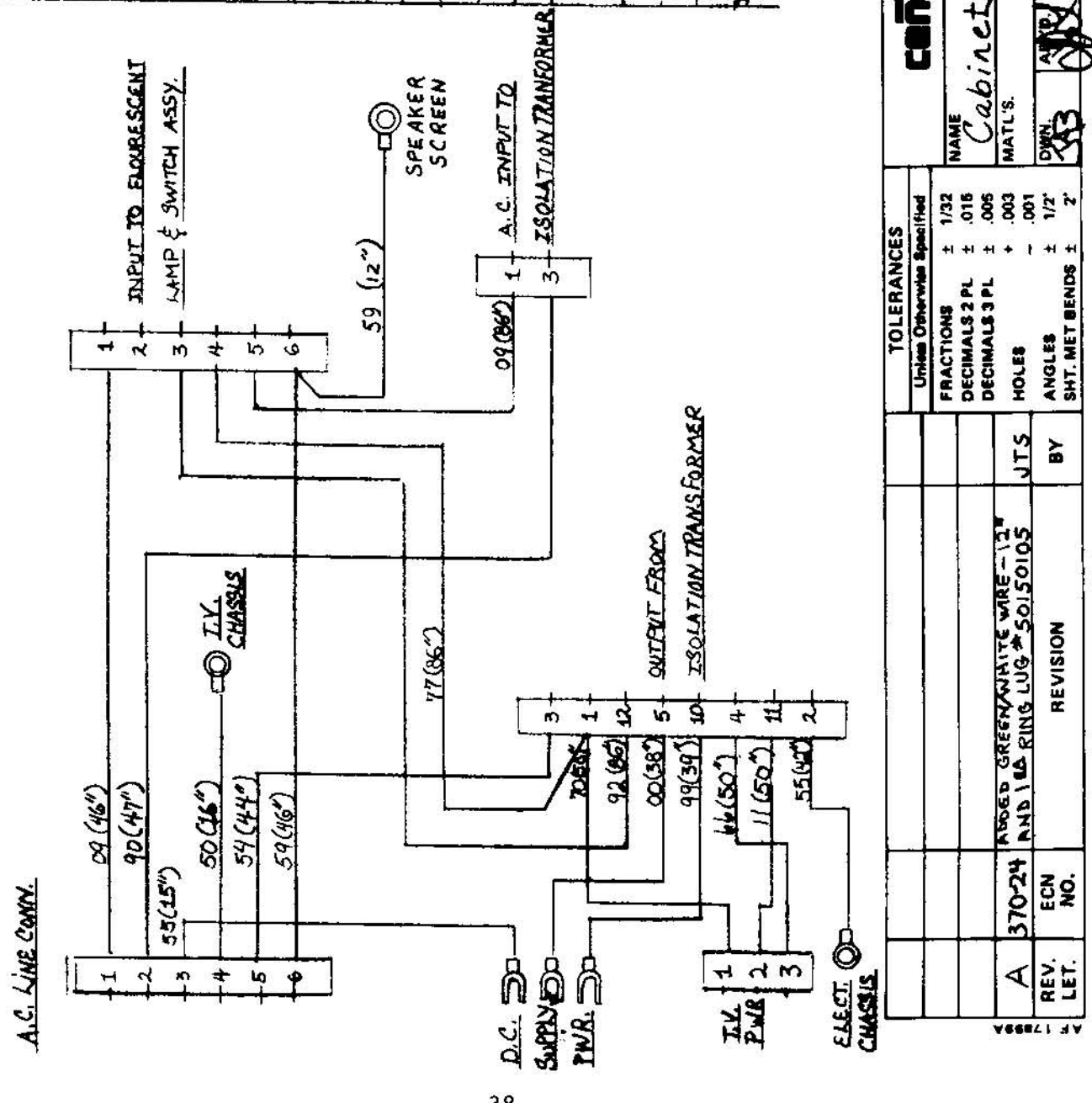

TOLERANCES	
Unless Otherwise Specified	
FRACTIONS	± 1/32
DECIMALS 2 PL	± .015
DECIMALS 3 PL	± .005
HOLES	- .003
ANGLES	± 1/2°
SHT. MET. BENDS	± 2°

REV. LET.	ECN NO.	REVISION	BY
A	370-24	ADDED GREEN/WHITE WIRE - 12" AND 1/4" RING LUG # 50150105	JTS

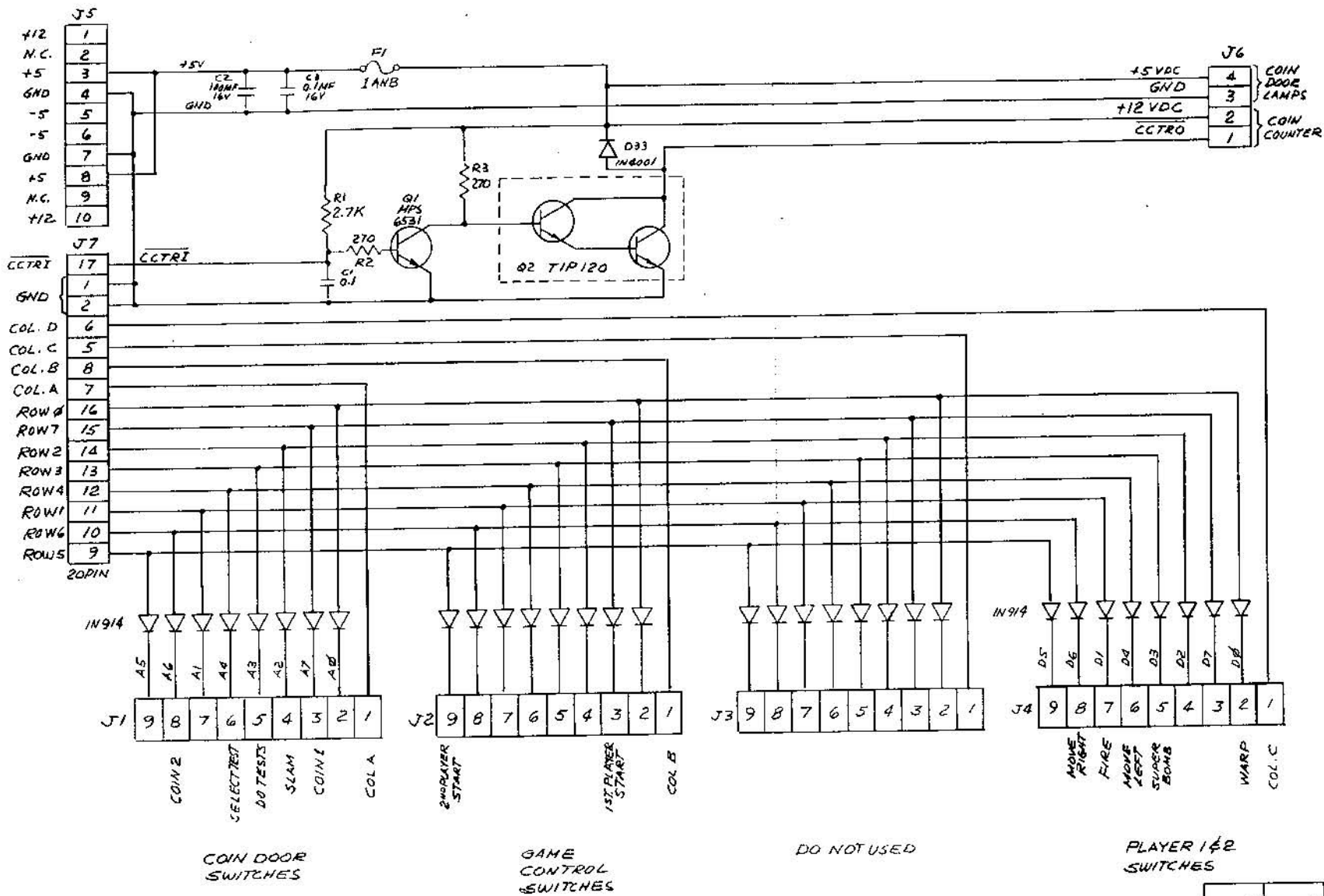

REV. LET.	ECN NO.	REVISION	BY	ANGLES	SMT. MGT BENDS	TOLERANCES (Unless Otherwise Specified)	NAME	DATE	SCALE	PART NO.	REV.
						FRACTIONS 2 1/32 DECIMALS 2 PL 0.10 DECIMALS 3 PL 0.05 HOLES 0.01 ANGLES 1/2° SMT. MGT BENDS 7	CENTURION GAMMA II PERIPHERAL INTERFACE Bd.	7-23-81	3/4"	374-17-0100	

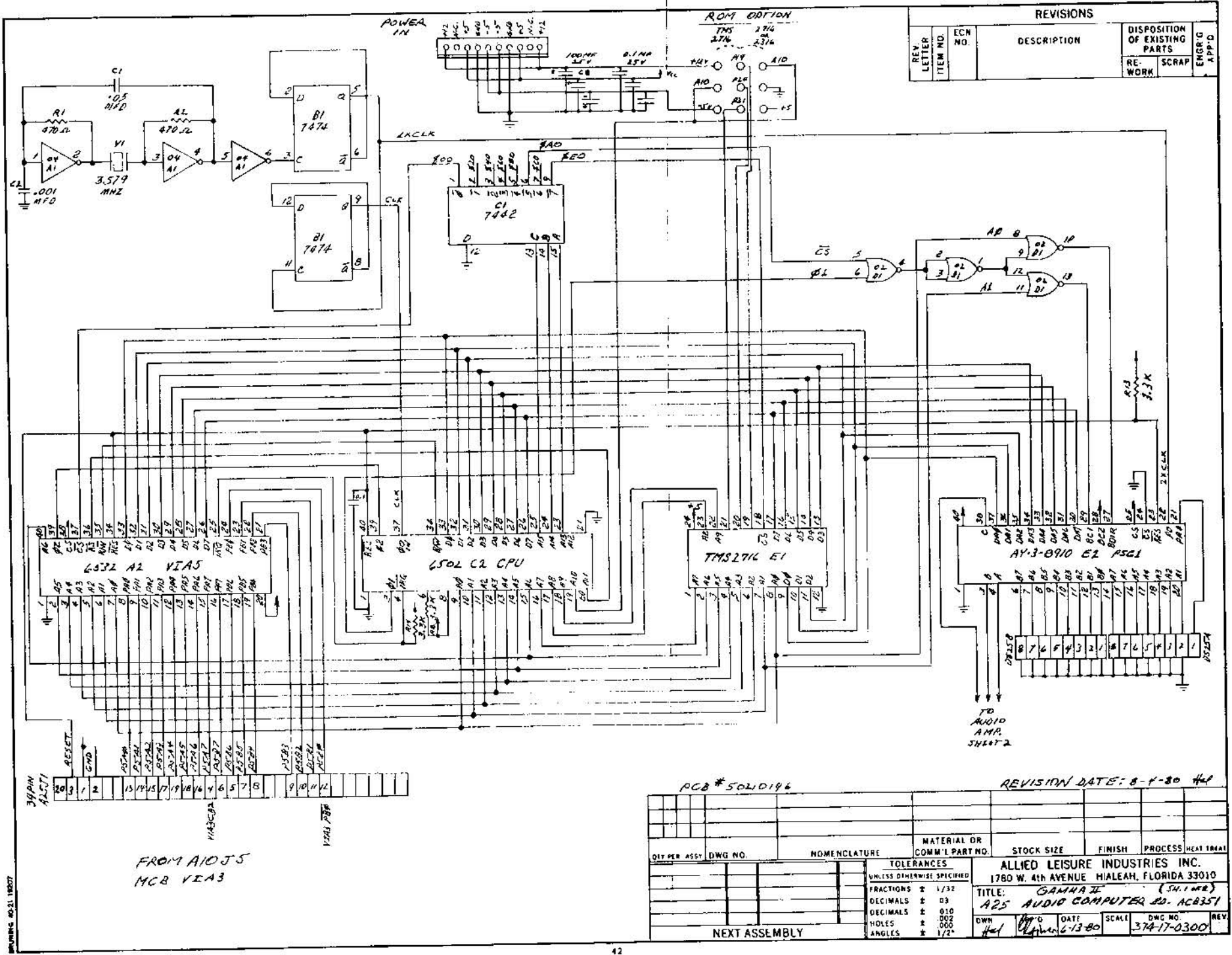

REV. LETTER		ECN NO.		DESCRIPTION	DISPOSITION OF EXISTING PARTS		ENGR'G APP'D
NO.	NO.	RE-WORK	SCRAP				

39PIN	45,71	1	2	3	4	5	6	7	8	9	10	11	12
RESET													

FROM A10JS
MCB VIA3

PCB # 5020196

REVISION DATE: 8-4-80 HLP

QTY PER ASSY	DWG NO.	NOMENCLATURE	MATERIAL OR COMM'L PART NO.	STOCK SIZE	FINISH	PROCESS	HEAT TREAT

TOLERANCES UNLESS OTHERWISE SPECIFIED	
FRACTIONS	± 1/32
DECIMALS	± .03
DECIMALS	± .010
HOLES	± .005
ANGLES	± 1/2°

ALLIED LEISURE INDUSTRIES INC.
1780 W. 4th AVENUE HIALEAH, FLORIDA 33010

TITLE: GAMMA II (SH. 1 WR)
A25 AUDIO COMPUTER BO. ACB351

OWN: HLP DATE: 6-13-80 SCALE: DWG NO: 374-17-0300 REV:

NEXT ASSEMBLY

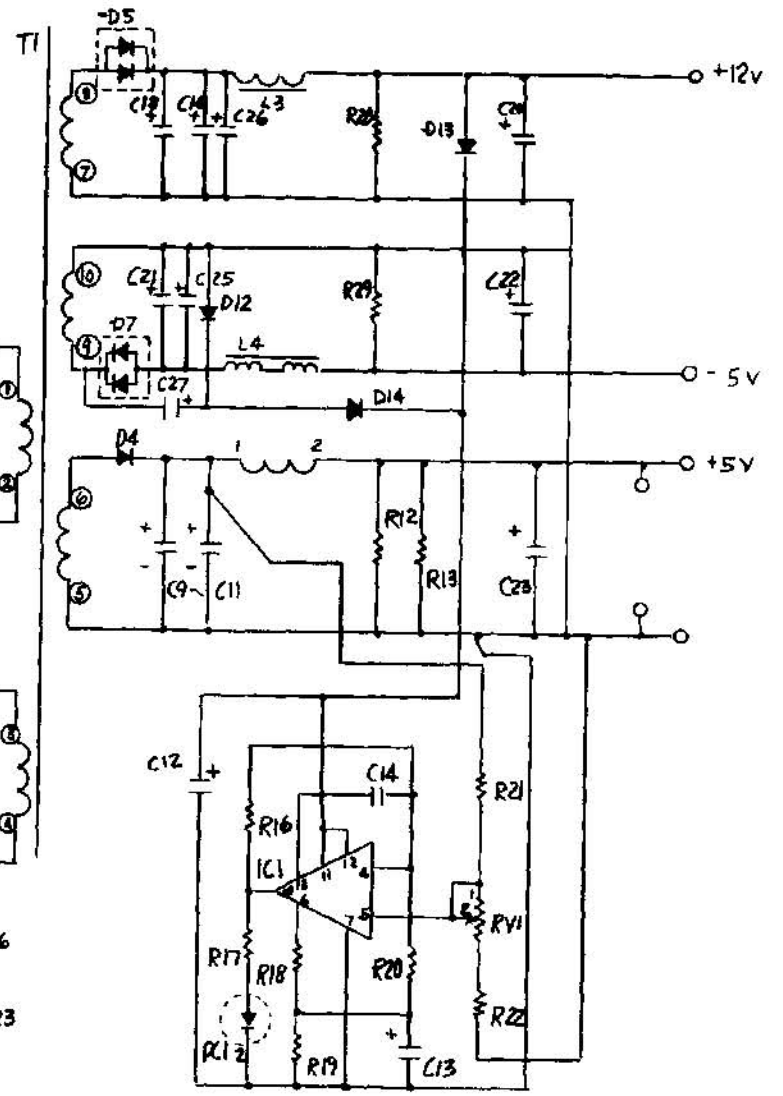
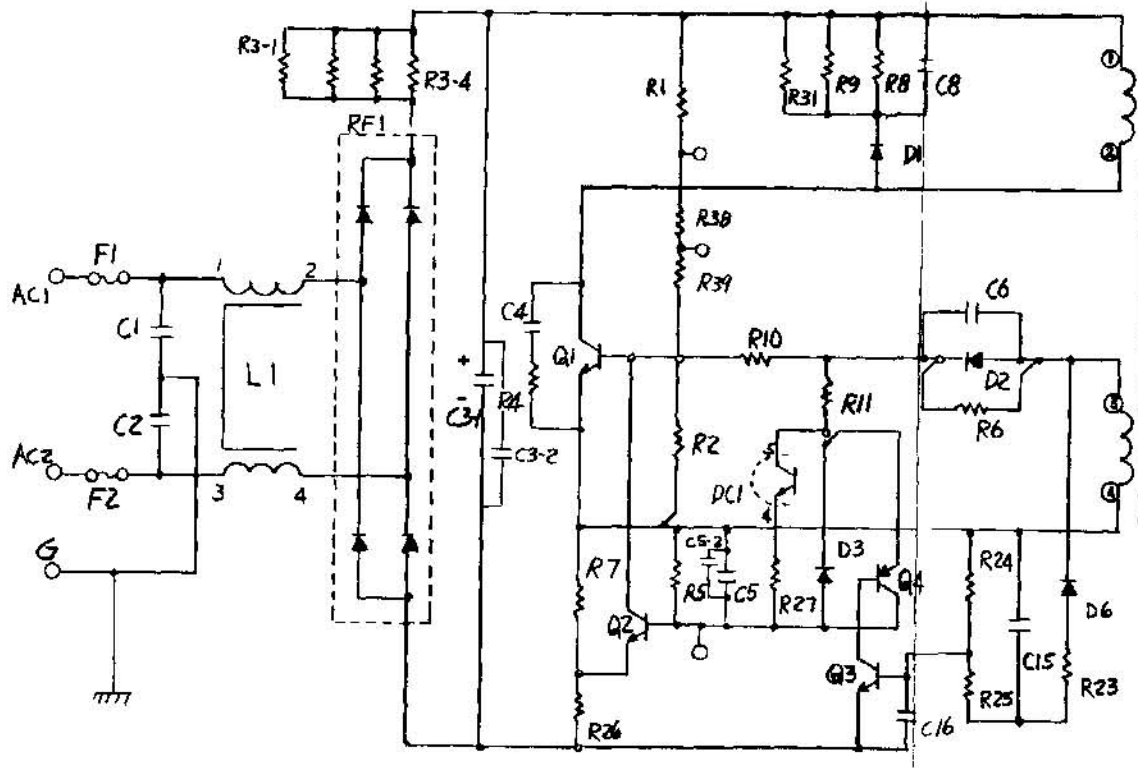

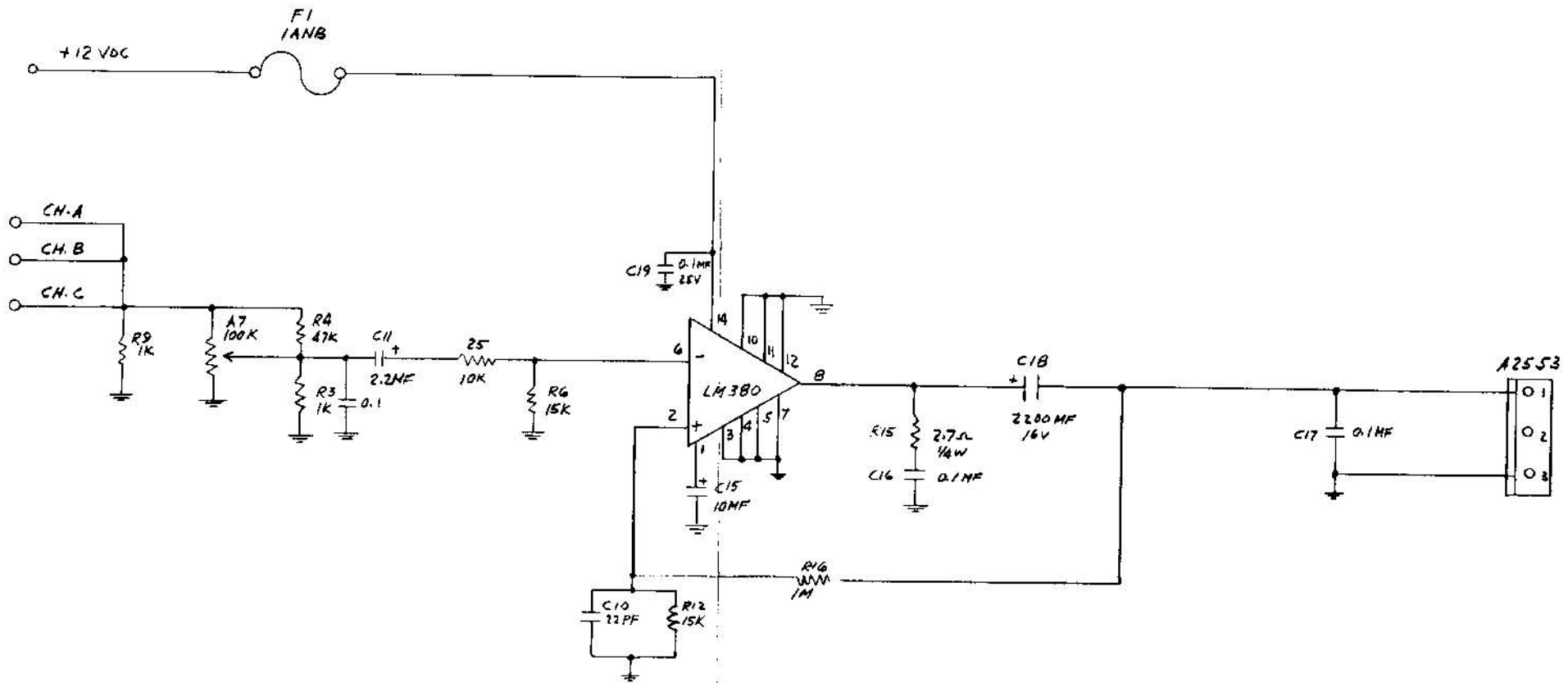

AUDIO AMPLIFIER

PCB 50210196

REVISION DATE: 7-26-80

ALL CAPS IN MFD @ 16V

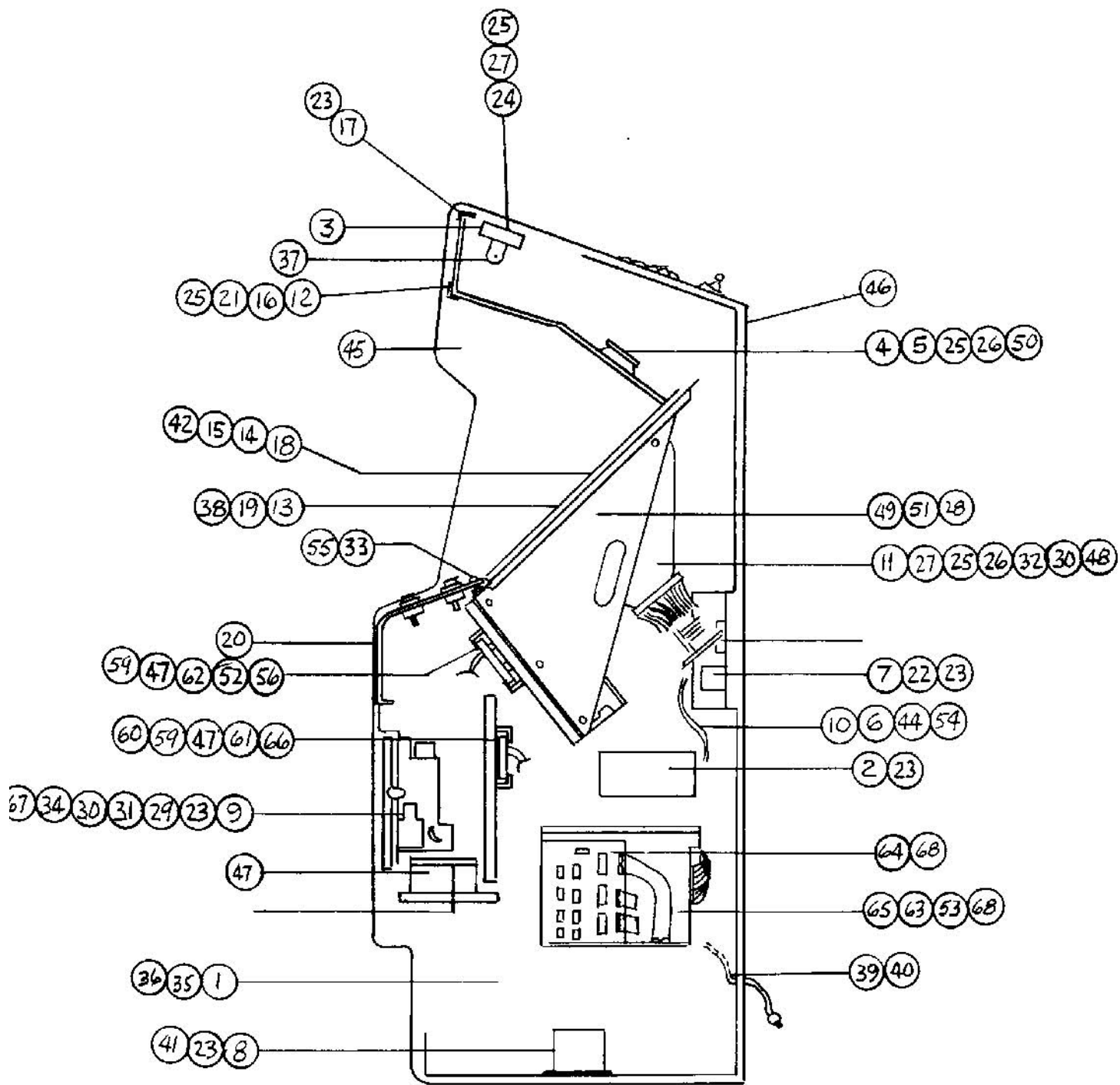
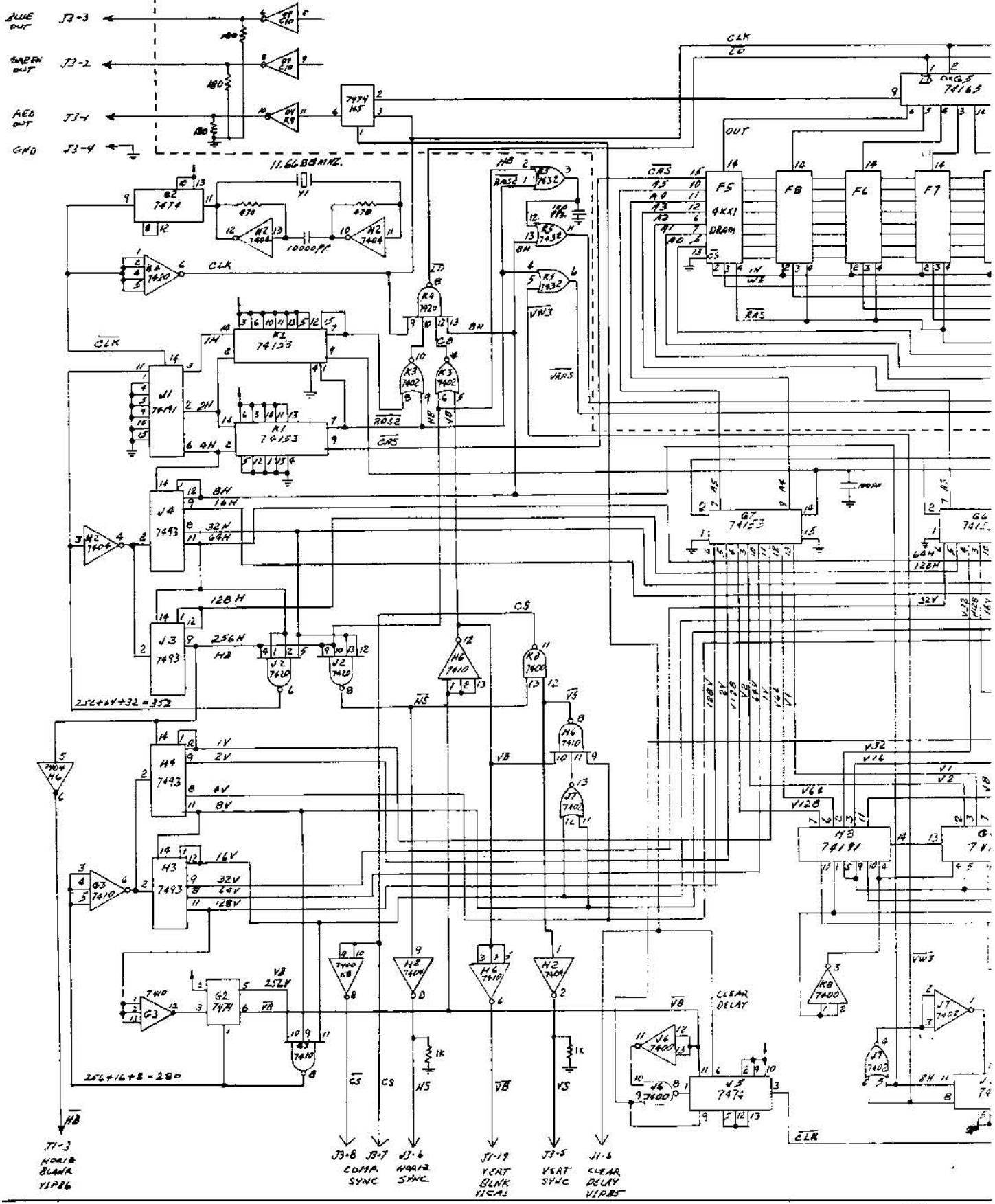
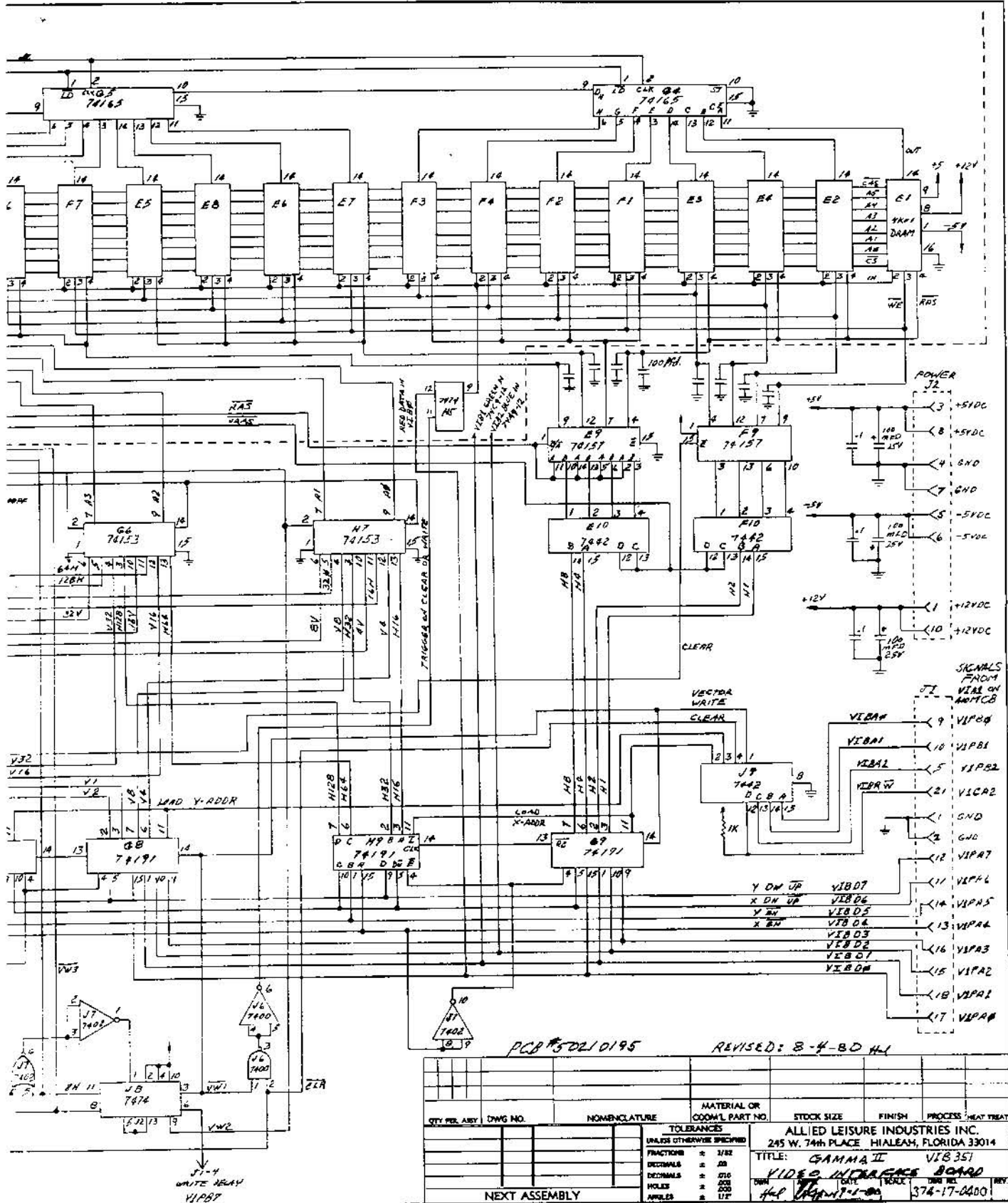

FIG. 4





PCB #50210195 REVISED: 8-4-80 HLI

CITY PER. ARBY.	DWG. NO.	NOMENCLATURE	MATERIAL OR QDOM/L PART NO.	STOCK SIZE	FINISH	PROCESS	HEAT TREAT
TOLERANCES UNLESS OTHERWISE SPECIFIED			ALLIED LEISURE INDUSTRIES INC.				
FRACTIONS * 1/32			245 W. 74th PLACE HIALEAH, FLORIDA 33014				
DECIMALS * .00			TITLE: GAMMA II VIB 351				
Holes * .010			DATE: _____ MADE: _____				
ANGLES * 1/16			DRAWN: _____				
NEXT ASSEMBLY			374-17-0400				

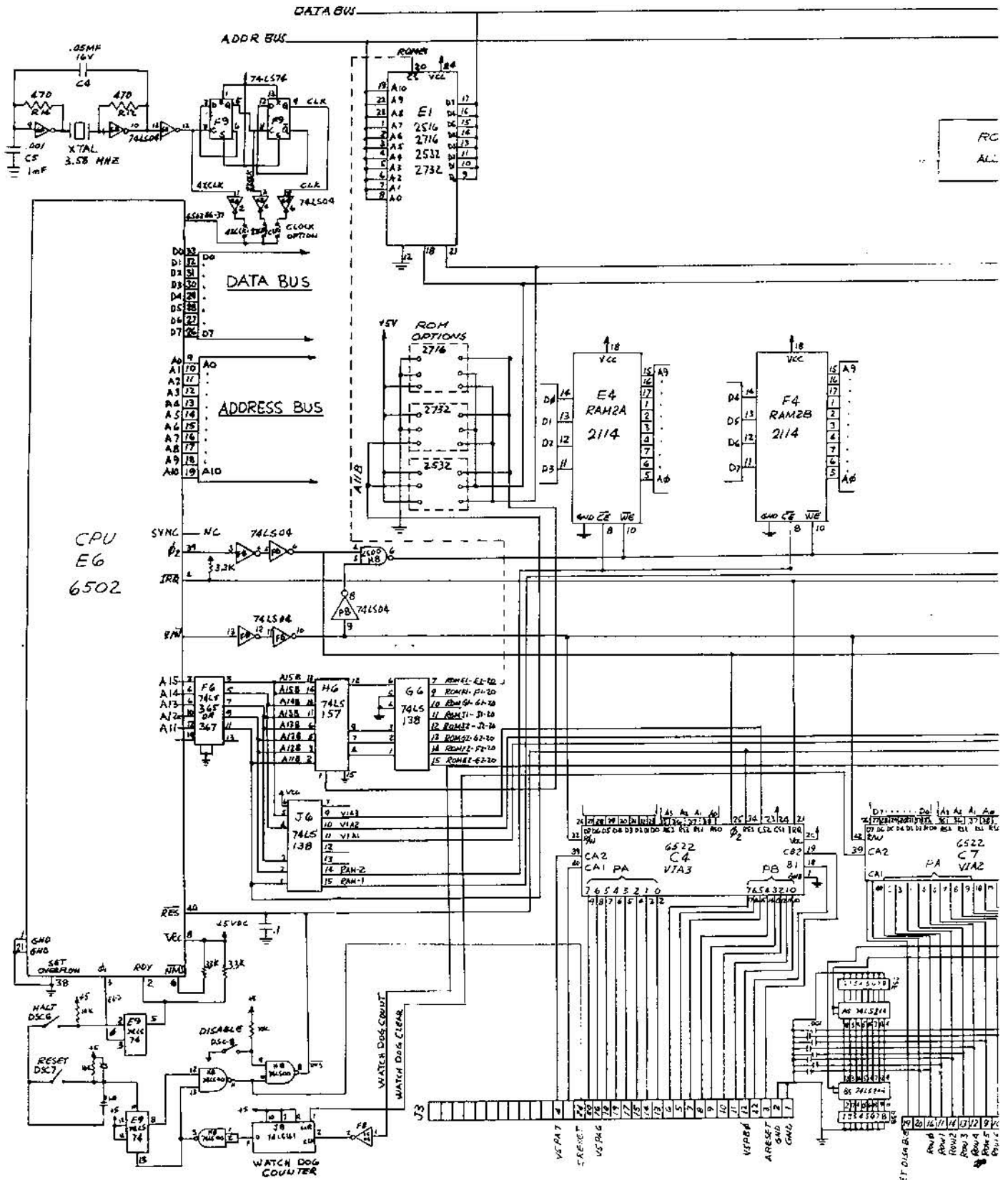

34 PIN TO AUX1

ROMS F1, G1, J1, J2, G2, F2 & E2
 ALL PINS SAME AS E1 EXCEPT PIN 20 (CS)

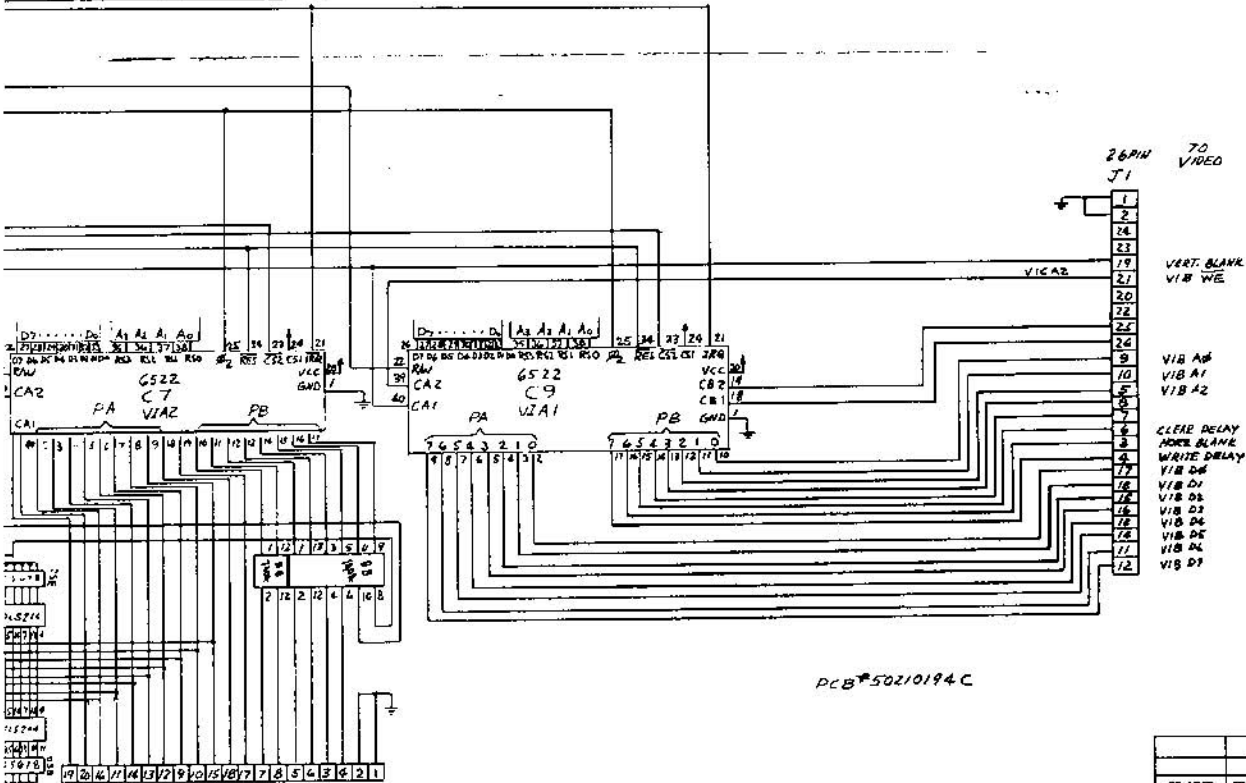
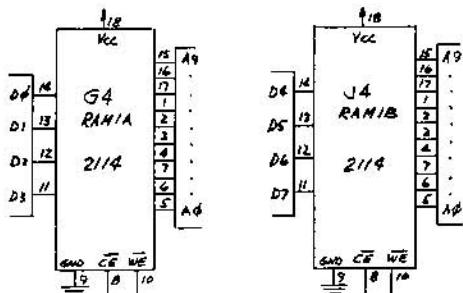

PCB #50210194 C

45

REV. LET.	EQ. NO.	REVISION	BY	DATE	SCALE	PART NO.	QTY.	ASSEMBLY NO.
				10-81		374-17-0200		

TOLERANCES		UNLESS OTHERWISE SPECIFIED	
FRACTIONS	1/32	NAME	GAMMA II C
DECIMALS 2 PL.	0.01	DESCRIPTION	MICRO COMPUTER BOARD
DECIMALS 3 PL.	0.001	MATERIAL	9mm
HOLE	0.01	HEAT TREAT.	
ANG. LES.	1/2	DATE	10-81
DET. MET. DIMS.	1/2	SCALE	374-17-0200