

GOSMIC AVENGER

Operation, Maintenance
and Service Manual

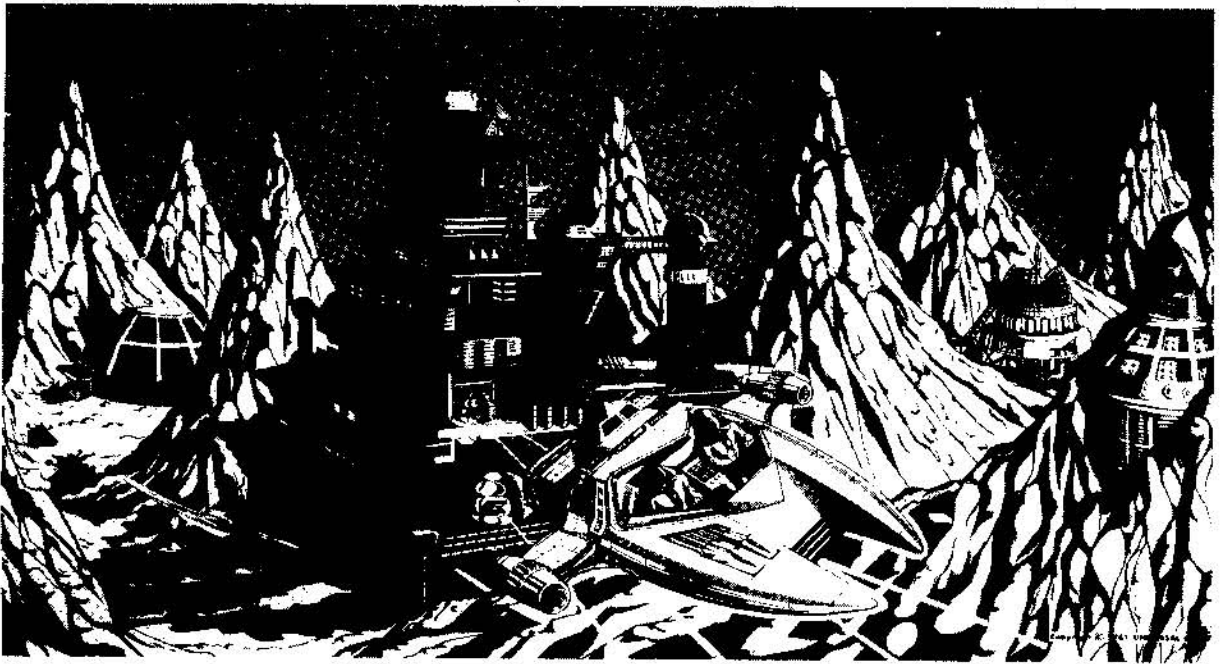

UNIVERSAL

CONTENTS

I. Features of this machine	1
II. How to handle and maintain this machine	2
III. How to play	3
IV. Various optional settings	4
A. Service switches and dip switches	4
V. TV monitor	5
A. Adjustment of TV picture screen	5
VI. Upright type parts catalog	6
A. Component parts related to cabinet (outside)	6
B. Drawing of circuit board mounting positions	7
C. Fuses	7
D. Component parts related to cabinet (inside)	8
a) Operating panel assembly	8
b) Door assembly and parts list	9
c) Lever assembly and parts list	10
E. Component parts related to switches in the cabinet	11
VII. Table type parts catalog	12
A. Component parts related to cabinet (outside)	12
B. Component parts related to cabinet (inside)	13
a) Inside cabinet	13
b) Fuses	14
c) Operating panel assembly	14
VIII. Circuit board	15
A. Circuit board IC location and parts list	15
a) Main circuit board IC location and parts list	15
b) Power circuit board IC and other element location, and parts list	17
Wiring diagram (connector)	19
Schematic diagram (20" color)	20
Schematic diagram (20" color)	21
Schematic diagram (14" color)	22
Main block diagram	23
Power source block diagram (Table type)	24
Power source block diagram (Upright type)	25
Block diagram	25
Postface	25

REFERENCE DRAWINGS

Fig. 1	Positions of Volume Controller, Dip and Service Switches	4
Fig. 2	Positions of TV Monitor Controller (Upright type)	5
Fig. 3	Positions of TV Monitor Controller (Table type)	5
Fig. 4	Component Parts Related to Cabinet (Outside)	6
Fig. 5	Circuit Board Mounting Positions	7
Fig. 6	Side View of Circuit Board Mounting Positions	7
Fig. 7	Fuses in the Power Source Unit	7
Fig. 8	Fuses in the Power Circuit Board	7
Fig. 9	Main Assemblies Related to Cabinet (Inside)	8
Fig. 10	Operating Panel Assembly	8
Fig. 11	Inside View of Door Assembly	9
Fig. 12	Lever Assembly	10
Fig. 13	Component Parts Related to Switches in the Cabinet	11
Fig. 14	Component Parts Related to Cabinet (Outside)	12
Fig. 15	Component Parts Related to Cabinet (Inside)	13
Fig. 16	Fuses in the Power Source Unit and Power Circuit Board	14
Fig. 17	Fuse on the Cabinet Side	14
Fig. 18	Operating Panel Assembly	14
Fig. 19	Main Circuit Board	15
Fig. 20	Power Circuit Board	17

— WHEN ORDERING PARTS —

Since each component part is indicated by block, definitely specify both the corresponding Fig. No. and part No. within the Fig. when placing an order for it.

I. FEATURES OF THIS MACHINE

1. The game packs in excellent features captivating players.
2. The lever control system is simple to handle.
3. By combining dip switches you can select among a variety of game modes – the number of spaceships, extra score (bonus points), etc.
Additionally, by means of dip switches you can select among 4 degrees of difficulty in play.
4. Dip switch combinations are also available to cover almost all kinds of game charge settings.
5. The highest score for the day is always displayed on the screen, and the 5 highest scorers can enter their names on the screen as well (dip switch combinations are also available to select among different number of letters used to register player name).
6. Finely designed cabinet and fascinating acoustic effects.











II. HOW TO HANDLE AND MAINTAIN THIS MACHINE

1. Since the UNIVERSAL's COSMIC AVENGER employs a color TV receiving set, be careful not to shake it during transit and when carrying it about.
2. Install it at a location which is not exposed to direct sunlight. In order to prevent the inside temperature rising, avoid as much as possible a location near a heater, etc.
3. Since the grounding terminal is visible, be sure to connect it to a grounding conductor.
4. Insert the power cord into the outlet and turn on the switch.
5. Even if the solid-state module seems to be out of order, do not check the circuit by means of a circuit tester, etc., since the internal voltage of the tester, etc. may sometimes break down the IC.
6. Make sure the machine is well ventilated. If the temperature of the IC and transistor is lower than 60°C, the function normally and may be considered reliable. If it exceeds 60°C, their performance cannot be guaranteed.
7. Make sure that the connector, etc. are not disconnected.
8. Whenever connecting the power cord of the solid-state module to, or disconnecting it from, the outlet, be sure to turn the power off.
9. Although the products of UNIVERSAL are manufactured with the utmost care, they may develop malfunctions when used for long periods. So, be sure to check this machine daily.

III. HOW TO PLAY

1. Your "Avenger" can be moved in 8 directions. The speed increases as it advances, while it decreases as it retreats.
2. Destroy the front enemy by pressing the Fire Button, and destroy the target below by pressing the Bomb Button.
3. The enemy UFO will assault you flying either from in front of you or from behind you. You can locate it by using the radar.
4. A tough chase missile will pursue your Avenger persistently. Dodge it successfully, and you can cause the enemy to fight among themselves.
5. When you pass the enemy radar site, an anti-aircraft gun will fire at you according to the altitude of your Avenger.
6. When the screen advances further, the X station will appear. When you destroy it in good time, you can destroy all the targets appearing on the screen at once. You are then awarded a high score.
7. Your Avenger will be destroyed when it is affected by any explosion.
8. The 1st - 5th highest scorers for the day can enter their names on the screen.

SCORE

 UFO	100 PTS	 Counter missile station	80 PTS	 Submarine	100 PTS
 Chase missile station..	80 PTS	 Station	100 PTS	 Mine	50 PTS
		 Anti-aircraft gun	50 PTS	 Depth bomb	50 PTS
		 Tank	130 PTS	 X station	300 PTS

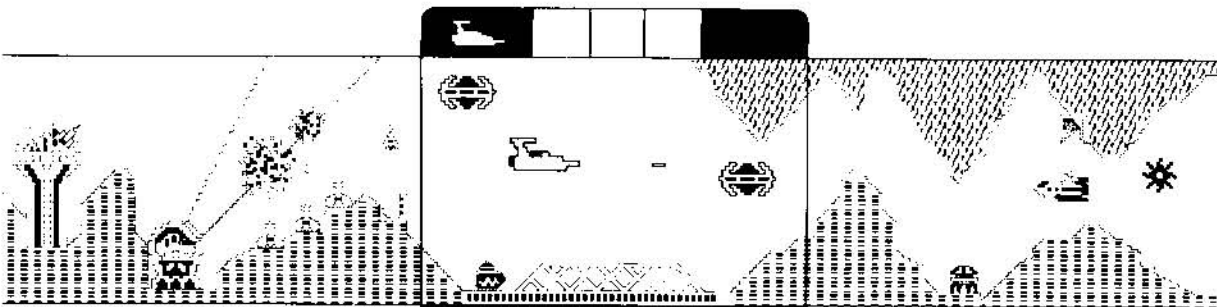

1ST 00000	TOP 00000
2ND 00000	

IV. VARIOUS OPTIONAL SETTINGS

A. SERVICE SWITCHES AND DIP SWITCHES

- Dip Switch A

1. Number of Spaceships (SW1, 2)

No. of Spaceships	SW1	SW2
3 Ships	OFF	OFF
4 Ships	OFF	ON
5 Ships	ON	OFF
2 Ships	ON	ON

2. Extra Score (SW3, 4)

Extra Score	SW3	SW4
5,000 PT	OFF	OFF
8,000 PT	OFF	ON
10,000 PT	ON	OFF
Nil	ON	ON

3. Game Style (SW5)

Style	SW5
Table	OFF
Upright	ON

4. Input Letters for High Score (SW6)

No. of Letters	SW6
0 ~ 10 Letters	OFF
0 ~ 3 Letters	ON

5. Difficulty of the Game (SW7, 8)

Difficulty	SW7	SW8
1	OFF	OFF
2	OFF	ON
3	ON	OFF
4	ON	ON

- Positions of Volume Controller, Dip and Service Switches

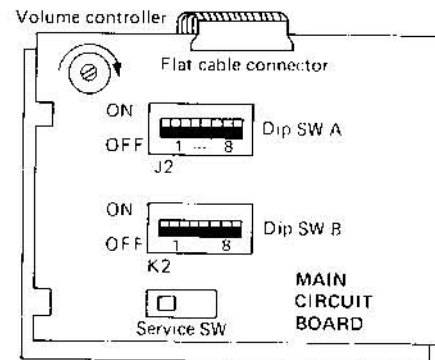

Fig. 1 Positions of Volume Controller, Dip and Service Switches

Service Switch

Pressing the service switch, the left-hand chute is set and the number of credit/s increases.

- Dip Switch B (Coin & Credit)

Coin	Credit	Left-hand Chute				Right-hand Chute			
		SW1	SW2	SW3	SW4	SW5	SW6	SW7	SW8
1	1	OFF	OFF	OFF	OFF	OFF	OFF	OFF	OFF
1	2	OFF	OFF	OFF	ON	OFF	OFF	OFF	ON
1	3	OFF	OFF	ON	OFF	OFF	OFF	ON	OFF
1	4	OFF	OFF	ON	ON	OFF	OFF	ON	ON
1	5	OFF	ON	OFF	OFF	OFF	ON	OFF	OFF
2	1	OFF	ON	OFF	ON	OFF	ON	OFF	ON
2	2	OFF	ON	ON	OFF	OFF	ON	ON	OFF
3	1	OFF	ON	ON	ON	OFF	ON	ON	ON
3	2	ON	OFF	OFF	OFF	ON	OFF	OFF	OFF
4	1	ON	OFF	OFF	ON	ON	OFF	OFF	ON
1	1	ON	OFF	ON	OFF	ON	OFF	ON	OFF
1	1	ON	OFF	ON	ON	ON	OFF	ON	ON
1	1	ON	ON	OFF	OFF	ON	ON	OFF	OFF
1	1	ON	ON	OFF	ON	ON	ON	OFF	ON
1	1	ON	ON	ON	OFF	ON	ON	ON	OFF
1	1	ON	ON	ON	ON	ON	ON	ON	ON

V. TV MONITOR

A. ADJUSTMENT OF TV PICTURE SCREEN

UPRIGHT TYPE

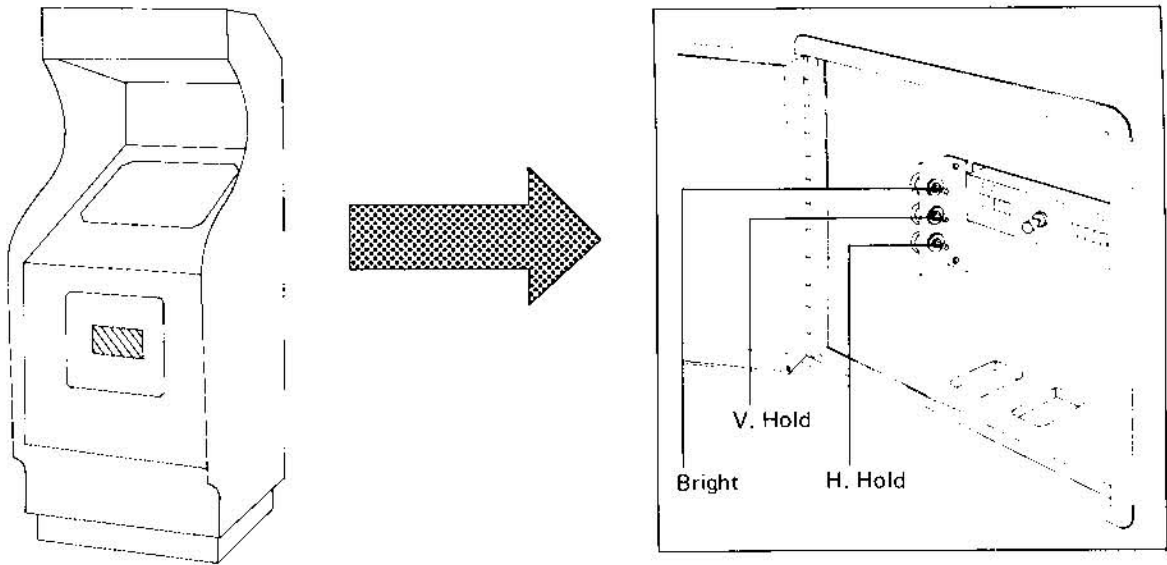

Fig. 2 Positions of TV Monitor Controller (Upright Type)

TABLE TYPE

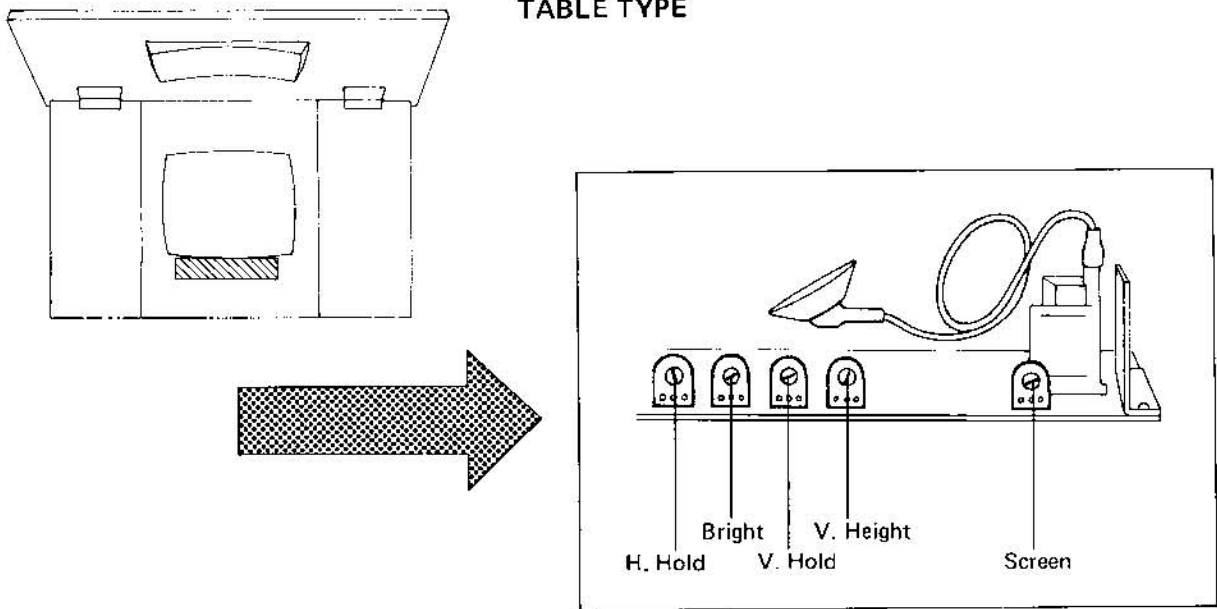

Fig. 3 Positions of TV Monitor Controller (Table Type)

UPRIGHT TYPE



This documentation provides standard information.
Universal reserves the right to change without notice.

VI. UPRIGHT TYPE PARTS CATALOG

A. COMPONENT PARTS RELATED TO CABINET (OUTSIDE)

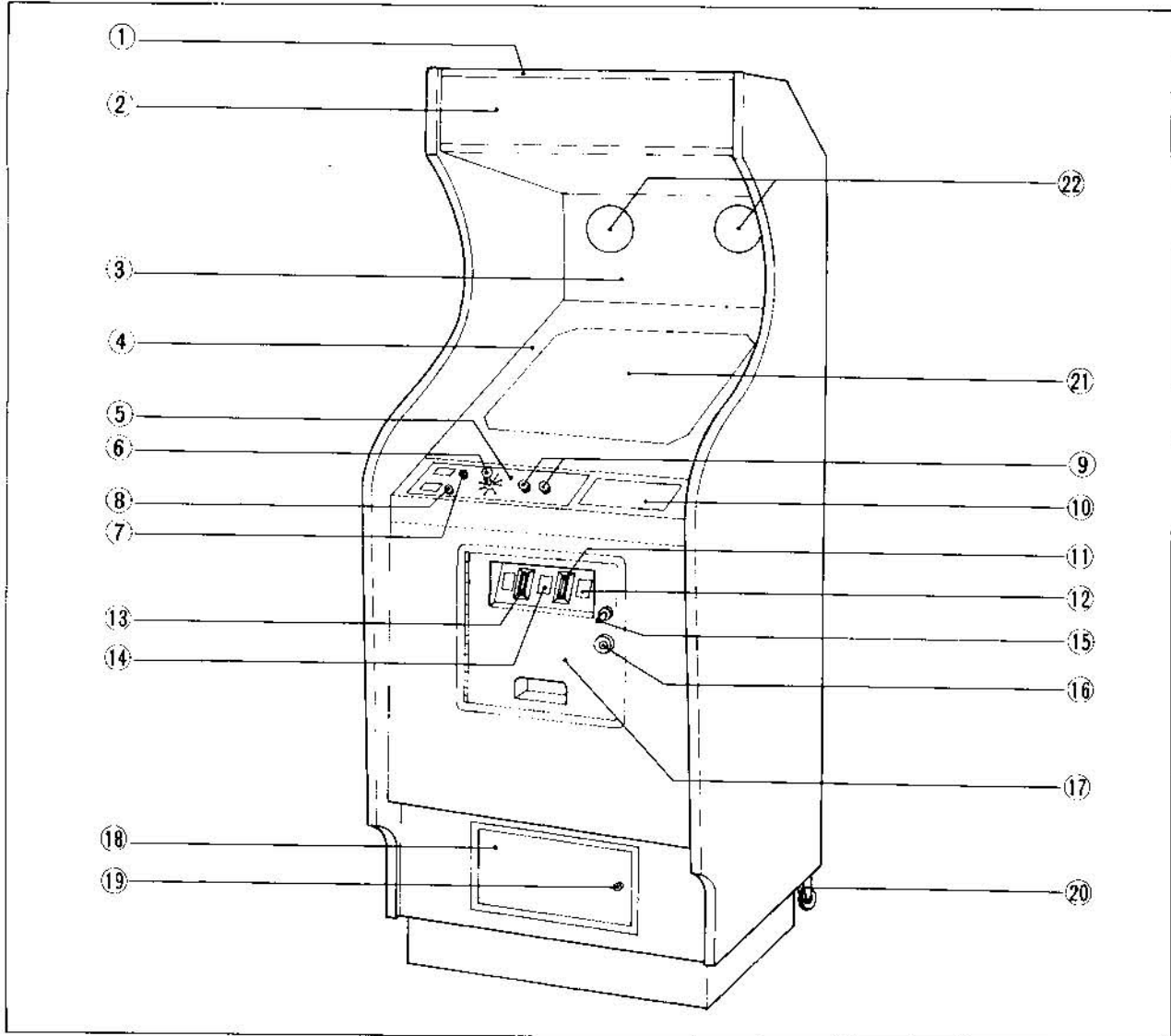

Fig. 4 Component Parts Related to Cabinet (Outside)

OUTSIDE CABINET PARTS LIST

Ref. No.	Name	Ref. No.	Name
1	Title panel fixture	12	Coin indication panel (1)
2	Title panel	13	Coin slot (2)
3	Illustrated glass (B)	14	Coin indication panel (2)
4	Illustrated glass (A)	15	Cancel button
5	Operating indication panel	16	Door key
6	Control lever (general name)	17	Main door
7	Push button (for 1 player)	18	Cash box door
8	Push button (for 2 players)	19	Cash box door key
9	Push button (fire and bomb)	20	Caster
10	Sticker for game rules	21	CRT (20" color)
11	Coin slot (1)	22	Speaker (x 2)

B. DRAWING OF CIRCUIT BOARD MOUNTING POSITIONS

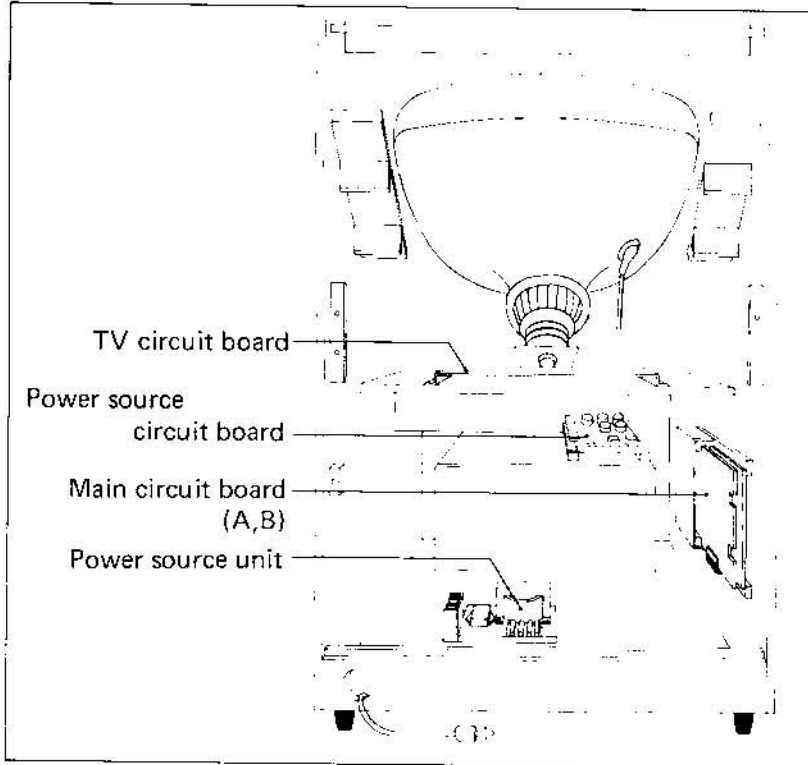

Fig. 5 Circuit Board Mounting Positions

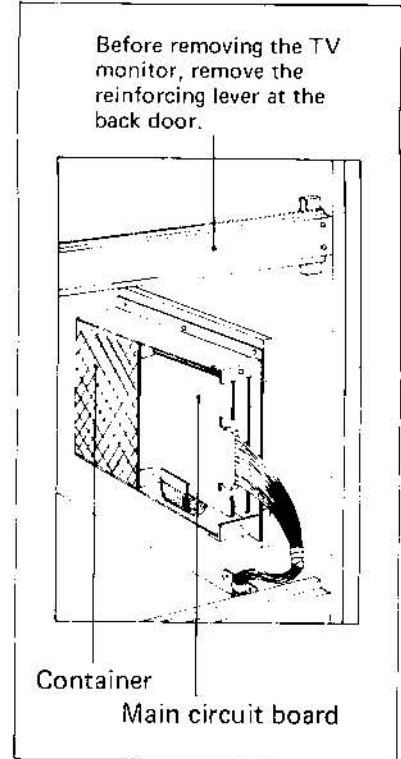

Fig. 6 Side View of Circuit Board Mounting Positions

C. FUSES

Fuses in the power source unit

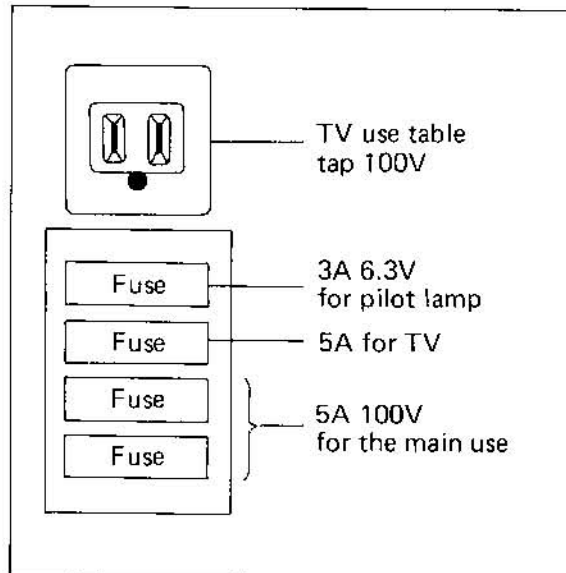

Fig. 7 Fuses in the Power Source Unit

Fuses in the power circuit board

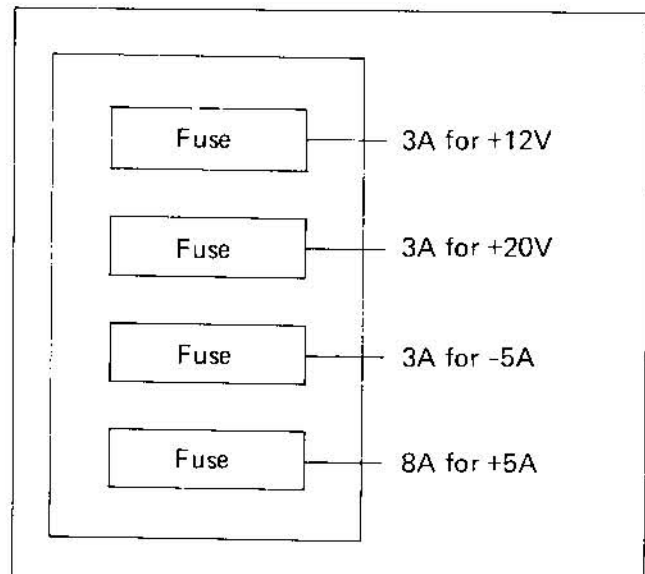

Fig. 8 Fuses in the Power Circuit Board

D. COMPONENT PARTS RELATED TO CABINET (INSIDE)

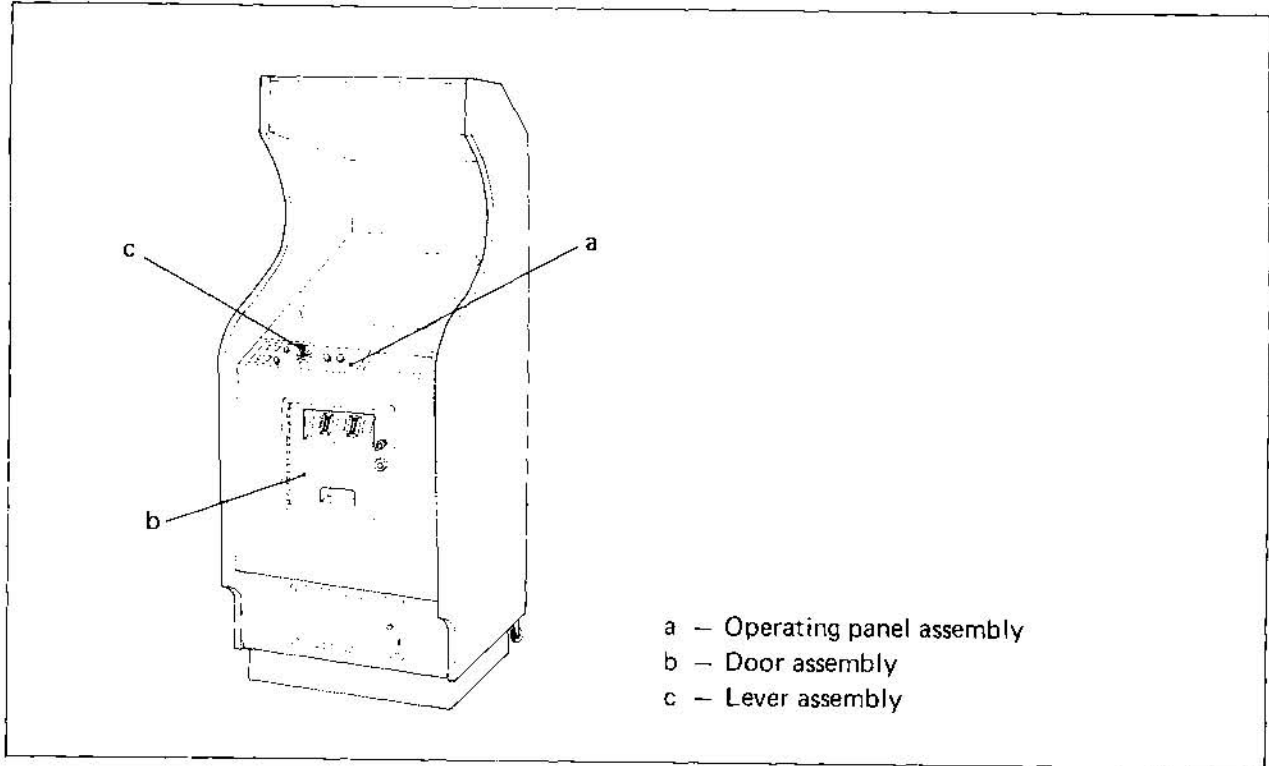

Fig. 9 Main Assemblies Related to Cabinet (Inside)

a) Operating panel assembly

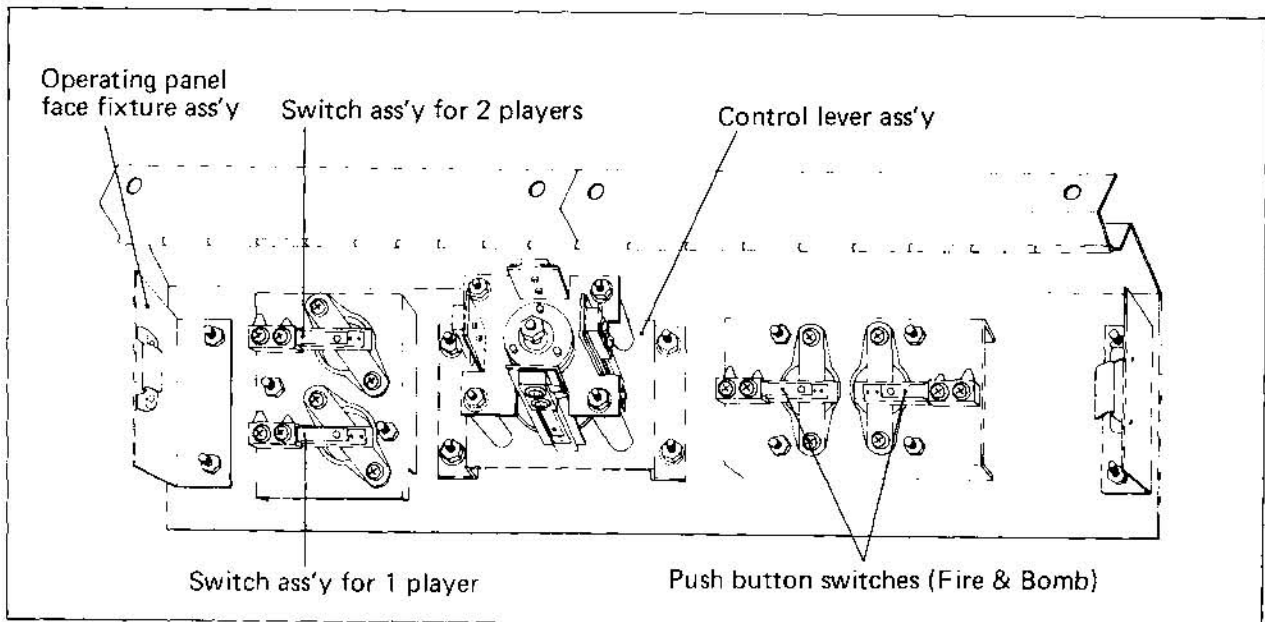

Fig. 10 Operating Panel Assembly

b) Door assembly and parts list

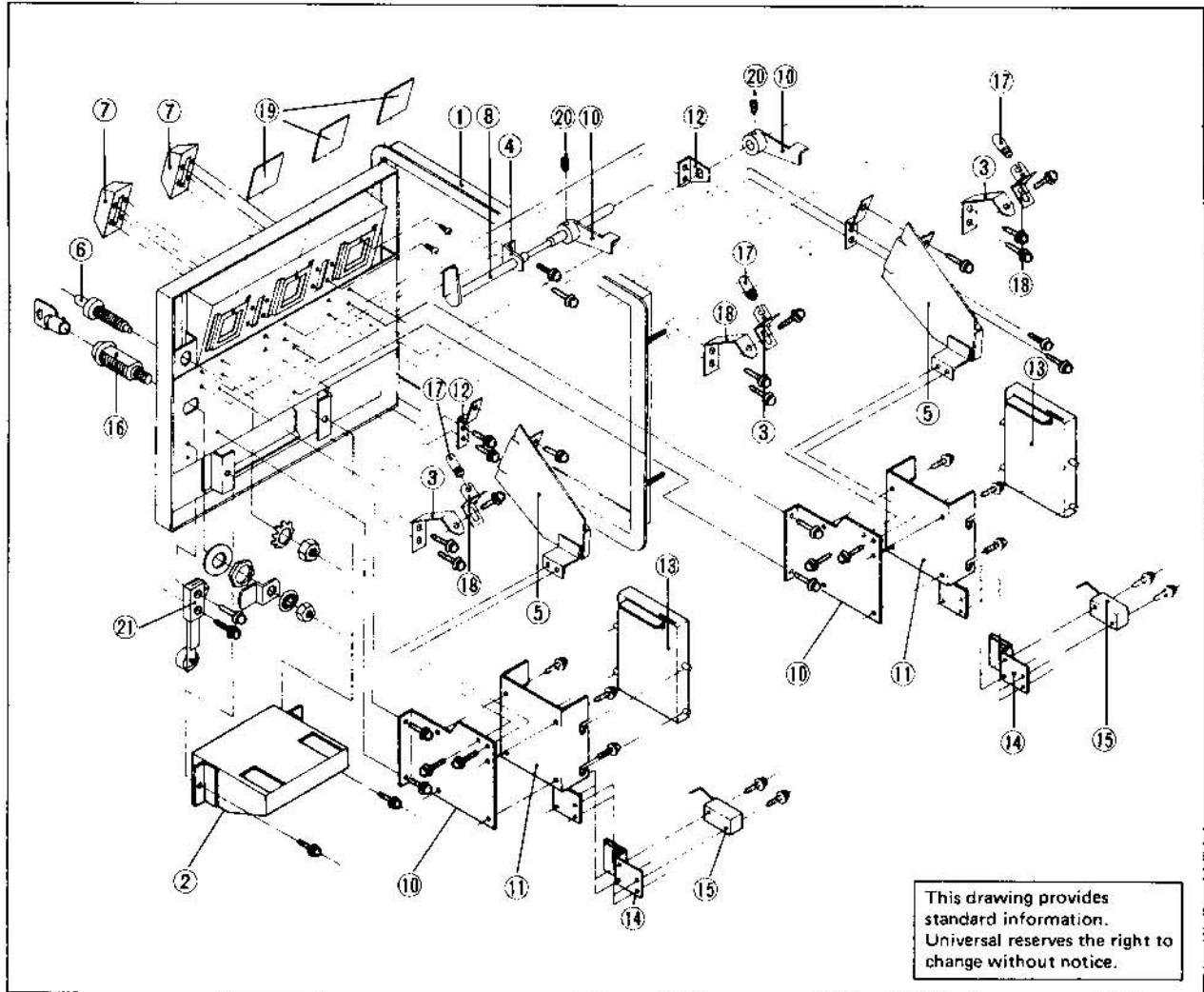

Fig. 11 Inside View of Door Assembly

DOOR ASSEMBLY PARTS LIST

Ref. No.	Name	Ref. No.	Name
1	Main door	12	Coin slot chute holder (x 2)
2	Returning saucer	13	Rejector (x 2)
3	Lamp bracket (x 3)	14	Sensor slot (x 2)
4	Rearing (x 2)	15	Micro switch
5	Coin slot chute (x 2)	16	Key sets
6	Returning button	17	Miniature lamp (x 3)
7	Coin slot (x 2)	18	Miniature lamp socket (x 3)
8	Transmission shaft	19	Coin indication panel (25φ x 2, coin slot)
9	Rotary bracket (x 2)	20	Hexagon socket head screw (x 2)
10	Rejector bracket (x 2)	21	Tilt switch
11	Rejector case (x 2)		

c) Lever assembly and parts list

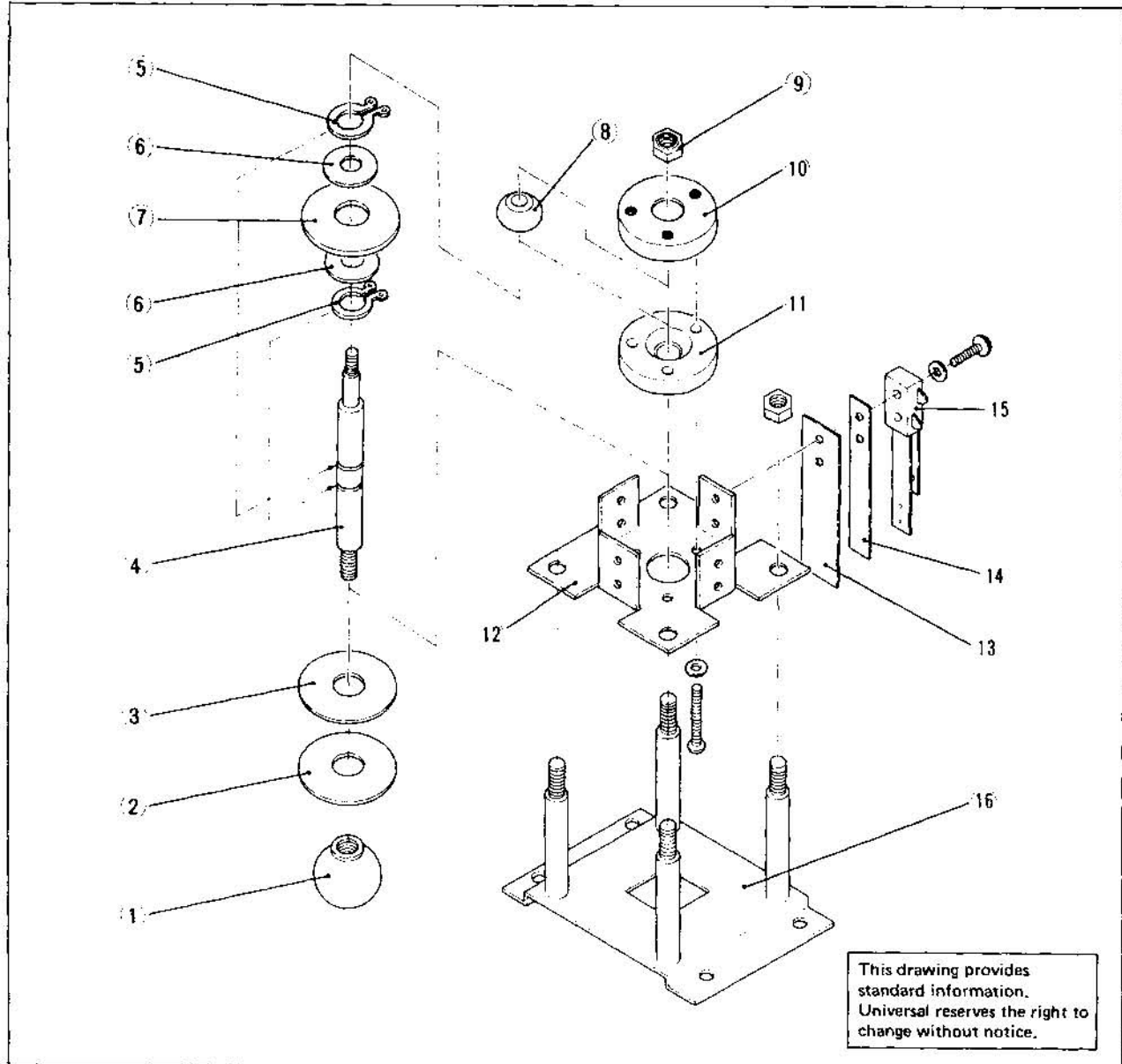

Fig. 12 Lever Assembly

LEVER ASSEMBLY PARTS LIST

Ref. No.	Name	Ref. No.	Name
1	Knob (upright 32Dim., Table 24Dim.)	9	Lock nut
2	Resin board (transparent)	10	Bracket (A)
3	Resin board (black)	11	Bracket (B)
4	Lever shaft	12	Blades mounting plate
5	Returning rings (C type)	13	Plate spring
6	Flat washer	14	Insulating fiber
7	Detecting dice	15	Blades switch
8	Steel ball	16	Mounting base

E. COMPONENT PARTS RELATED TO SWITCHES IN THE CABINET

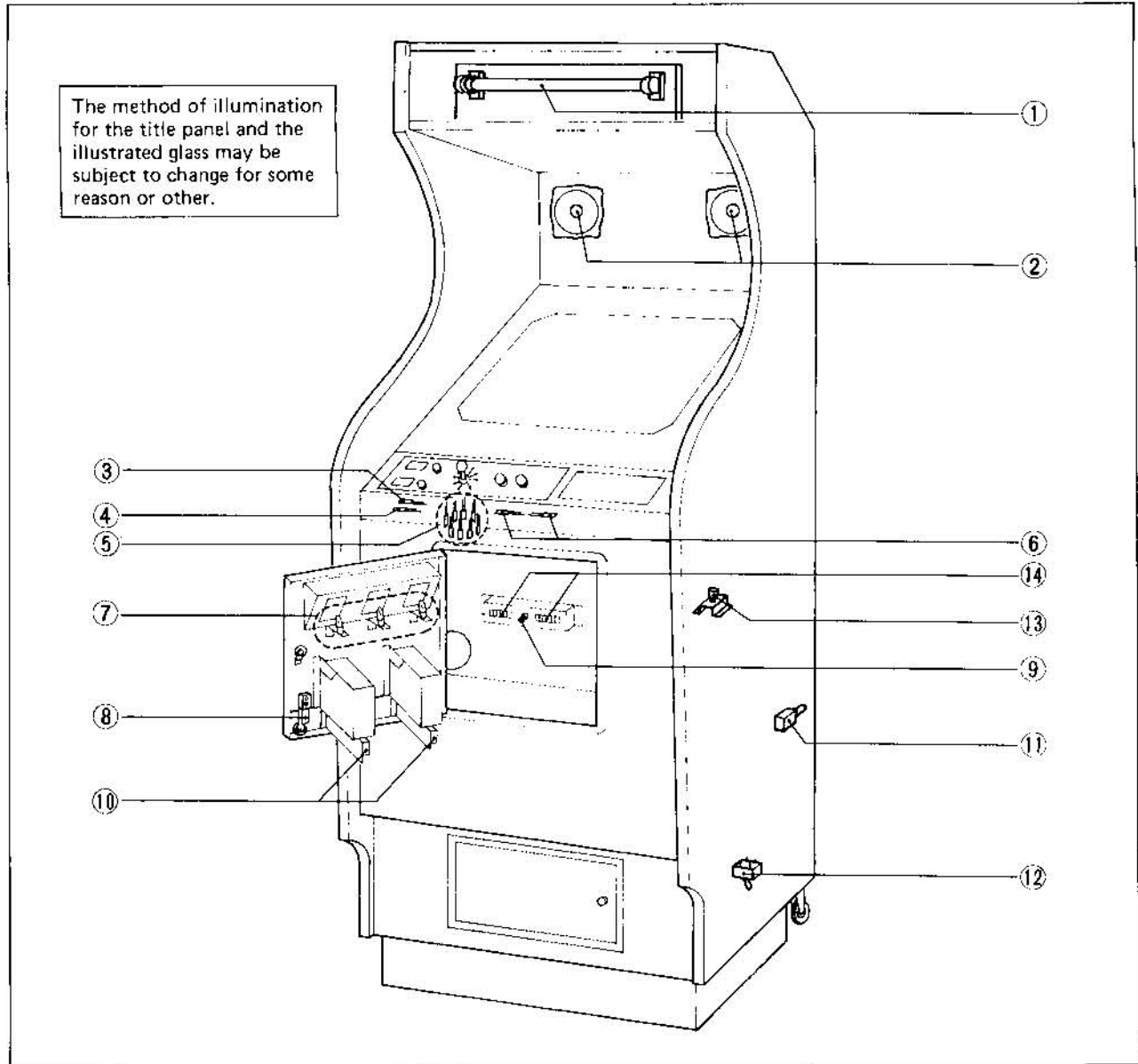
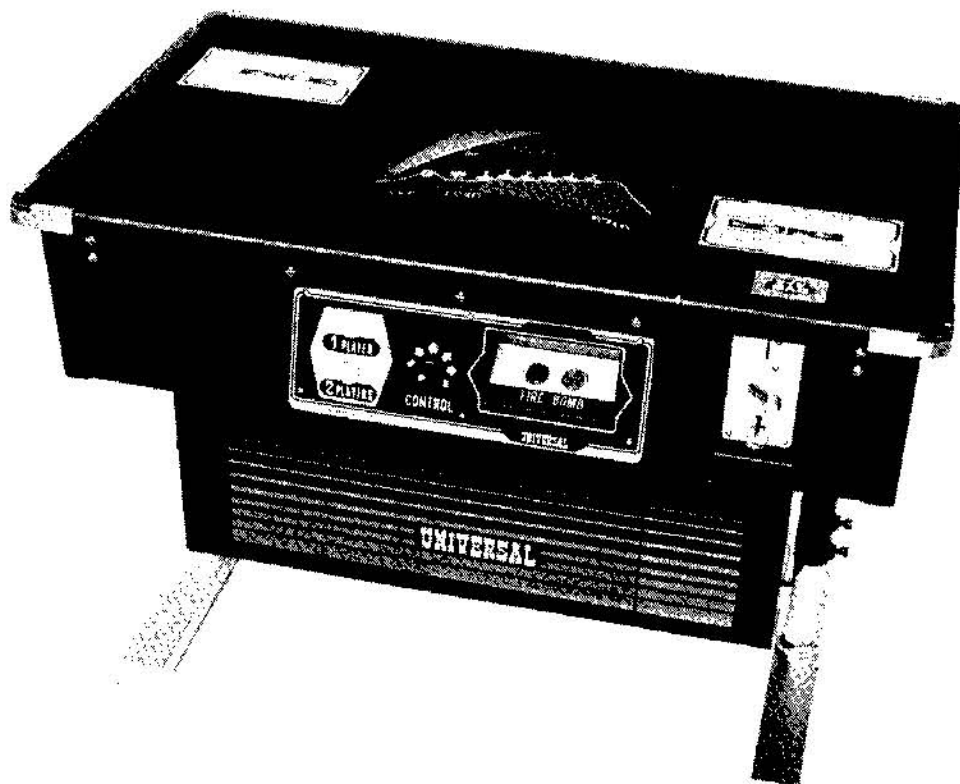

Fig. 13 Component Parts Related to Switches in the Cabinet

INSIDE CABINET PARTS LIST

Ref. No.	Name	Ref. No.	Name
1	Fluorescent lamp (for title panel)	8	Blade SW (for tilt SW)
2	Speaker (x 2)	9	Micro SW (for resetting)
3	1 player select button blade SW	10	Micro SW (for rejector x 2)
4	2 players select button blade SW	11	Door SW
5	Control lever 8-directional use blade SW (x8)	12	Toggle SW
6	Blade SW for fire and bomb	13	Micro SW (for demagnetization)
7	Miniature lamp (for money display x 3)	14	Coin counter (x 2)

TABLE TYPE



This documentation provides standard information.
Universal reserves the right to change without notice.

VII. TABLE TYPE PARTS CATALOG

A. COMPONENT PARTS RELATED TO CABINET (OUTSIDE)

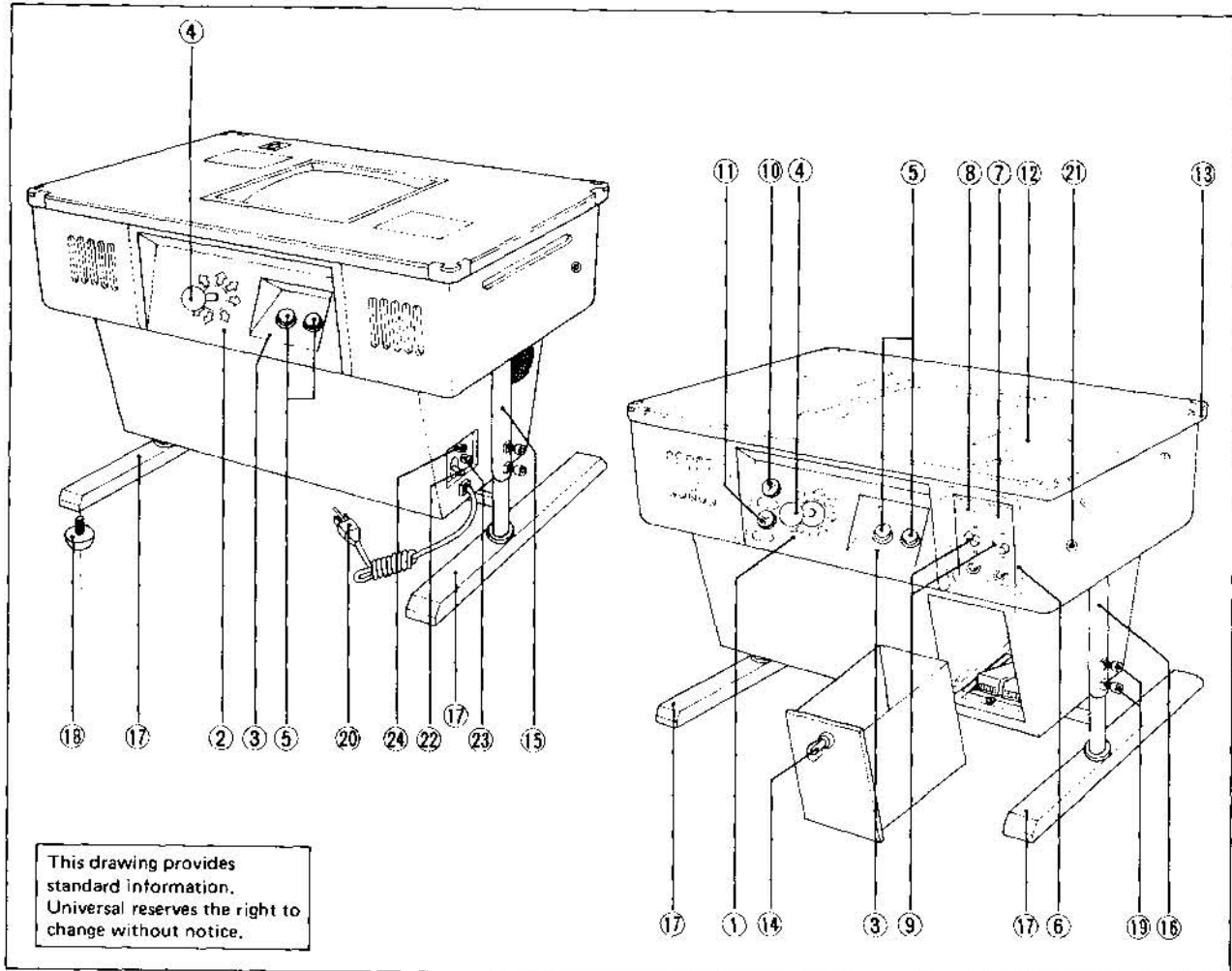

Fig. 14 Component Parts Related to Cabinet (Outside)

OUTSIDE CABINET PARTS LIST

Ref. No.	Name	Ref. No.	Name
1	Operating indication illustrated panel A (for 1st player side)	12	Sticker for game rules (x 2)
2	Operating indication illustrated panel B (for 2nd player side)	13	Glass fittings (x 4)
3	Operating indication illustrated panel C	14	Cash box key
4	Control lever ass'y	15	Leg (left)
5	Push button (for fire and bomb)	16	Leg (right)
6	Coin slot frame	17	Foot
7	Selector plate (1)	18	Leg adjuster
8	Selector plate (2) [not used in case of 1-way]	19	Thumbscrew (x 4)
9	Cancel lever	20	Power cord (AC)
10	Push button ass'y (for 1 player)	21	Table key (x 2)
11	Push button ass'y (for 2 players)	22	Toggle SW (Main)
		23	Fuse (3A for power input)
		24	Earth jack

B. COMPONENT PARTS RELATED TO CABINET (INSIDE)

a) Inside cabinet

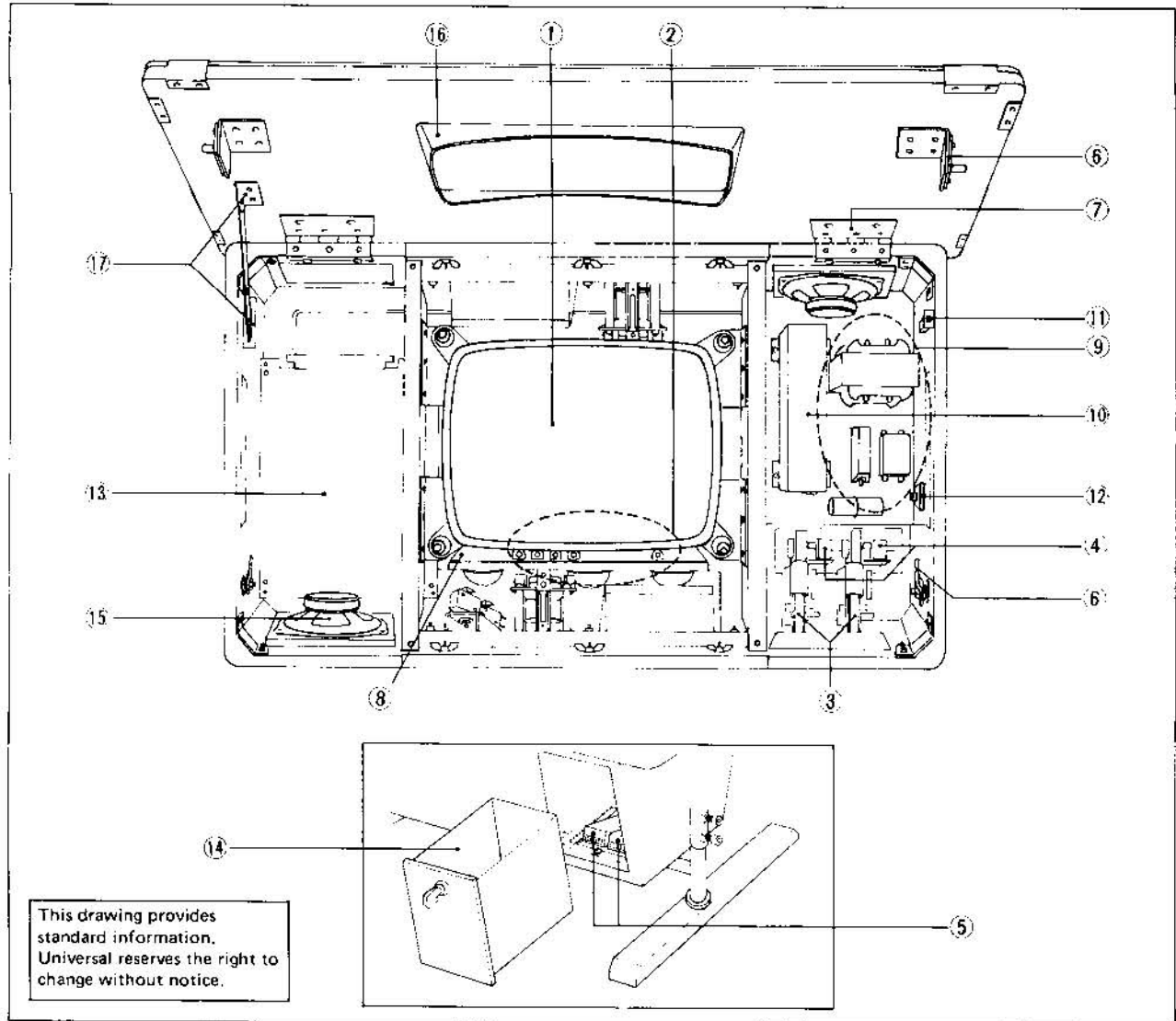

Fig. 15 Component Parts Related to Cabinet (Inside)

INSIDE CABINET PARTS LIST

Ref. No.	Name	Ref. No.	Name
1	CRT (14" color)	10	Power supply unit
2	TV monitor control	11	Door switch
3	Rejector ass'y	12	Demagnetization switch
4	Coin micro switch	13	Main circuit board (A, B)
5	Coin counter	14	Cash box
6	Table lock mechanism ass'y	15	Speaker (x 2)
7	Butterfly plate ass'y	16	TV monitor mask
8	TV monitor circuit board	17	Hood guide ass'y
9	Power source unit		

b) Fuses

Fuses in the power source unit and power circuit board

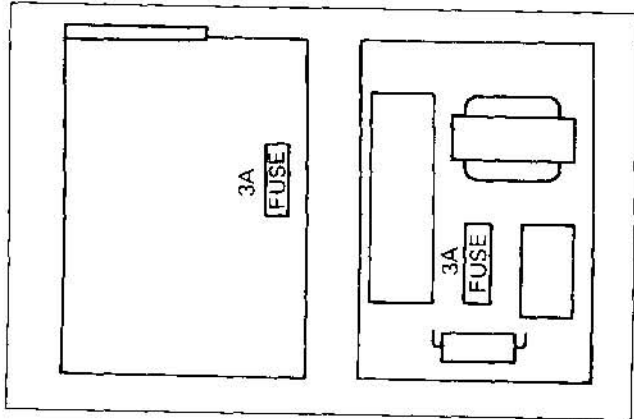

Fig. 16 Fuses in the Power Source Unit and Power Circuit Board

Fuse on the cabinet side

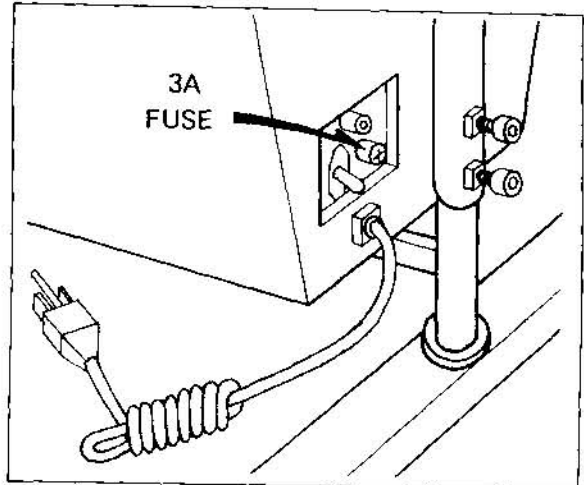

Fig. 17 Fuse on the Cabinet Side

c) Operating panel assembly

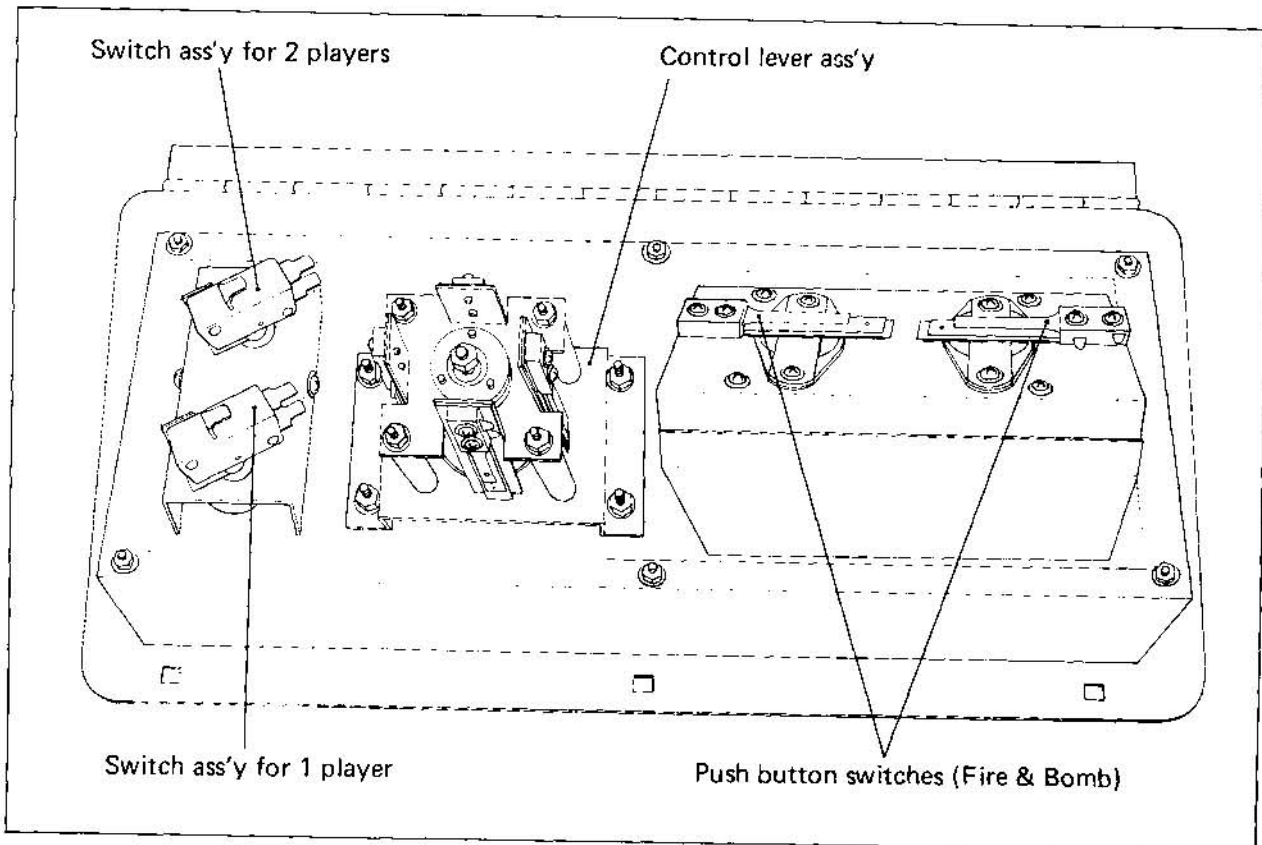
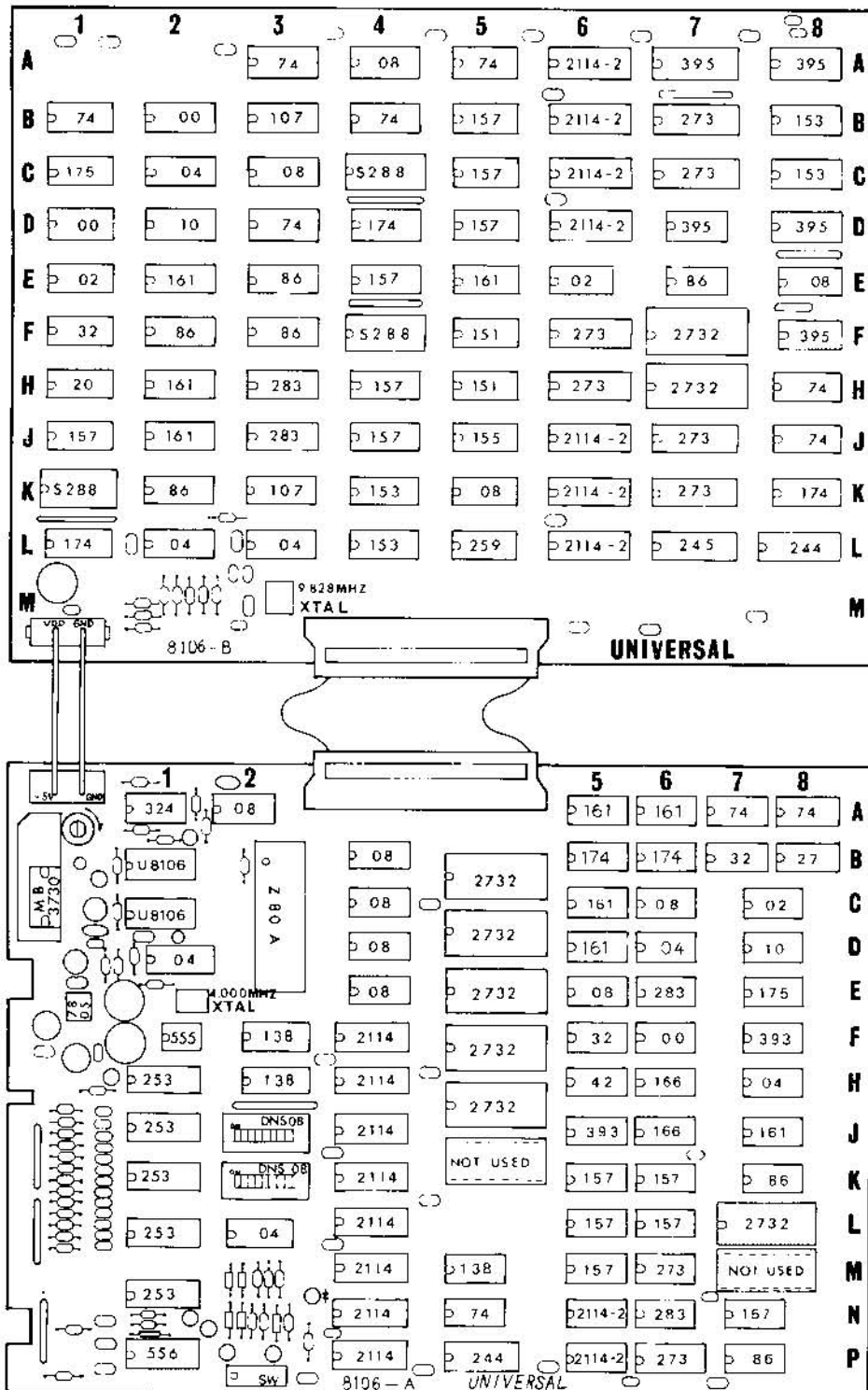

Fig. 18 Operating Panel Assembly

VIII. CIRCUIT BOARD

A. CIRCUIT BOARD IC LOCATION AND PARTS LIST

a) Main circuit board IC location and parts list



This drawing provides standard information. Universal reserves the right to change without notice.

Fig. 19 Main Circuit Board

UNIVERSAL

[1] Integrated Circuit

Item No.	Q'ty	Description
74LS 00	3	TTL
74LS 02	3	"
74LS 04	5	"
74 04	1	"
74 S 04	1	"
74LS 08	11	"
74LS 10	2	"
74LS 20	1	"
74LS 27	1	"
74LS 32	3	"
74LS 42	1	"
74LS 74	9	"
74LS 86	7	"
74LS107	2	"
74LS138	3	"
74LS151	2	"
74LS153	4	"
74LS155	1	"
74LS157	13	"
74LS161	9	"
74LS166	2	"
74LS174	6	"
74LS175	2	"
74LS244	2	"
74LS245	1	"
74LS253	5	"
74LS259	1	"
74LS273	8	"
74LS283	4	"
74 S288	3	256 bits Bipolar RAM (TBP18S030)
74LS393	2	TTL
74LS395	5	"
NE555	1	Timer
NE556	1	"
Z80A	1	Nch MOS CPU (4MHz)
2732	3	Nch MOS 32K bits EP ROM (Access 450nsec)
2732-35	5	Nch MOS 32K bits EP ROM (Access 350nsec)
2114	8	Nch MOS 4K bits Static RAM (Access 450nsec)
2114-2	9	Nch MOS 4K bits Static RAM (Access 250nsec)
SN76489	2	Sound Generation Controller
LM324	1	Quad Operational Amplifiers
MB3730	1	Power Amplifiers
MA7805	1	Regulator

[2] Other Semiconductor Devices

Item No.	Q'ty	Description
TLR103	1	LED
10D1	6	Diode

[3] Capacitors

Rating	Q'ty	Description
100P1/12V	2	Ceramic Capacitor
0.001 μ / "	1	"
0.01 μ / "	2	"
0.1 μ / "	54	"
0.1 μ /25V	3	"
1 μ /25V	1	Chemical Capacitor
47 μ /25	2	"
4.7 μ /25V	2	"
10 μ / "	2	"
22 μ / "	1	"
220 μ / "	4	"
470 μ / "	2	"

[4] Resistors

Rating	Q'ty	Description
20 Ω 1/4W	1	Carbon Solid
2K Ω 1/4W	2	"
100 Ω 1/4W	2	"
4.7 Ω "	2	"
47 Ω "	1	"
220 Ω "	18	"
330 Ω "	2	"
470 Ω "	6	"
510 Ω "	4	"
1K Ω "	1	"
4.7K Ω "	1	"
5.1K Ω "	1	"
10K Ω "	2	"
47K Ω "	1	"
51K Ω "	1	"
100K Ω "	3	"
MS1028AM	8	1K Ω Resistor Array
MS1024AM	1	"
MS1038AM	2	10K Ω Resistor Array
RV16YP or RGP102	1	1K Ω (B) Variable Resistor

[5] Misc

Name	Q'ty	Description
Dip SW	2	8 Elements Switch Array
X tal	2	9.828MHz
		4.000MHz
E61-00A	1	Micro SW

b) Power circuit board IC and other element location, and parts list

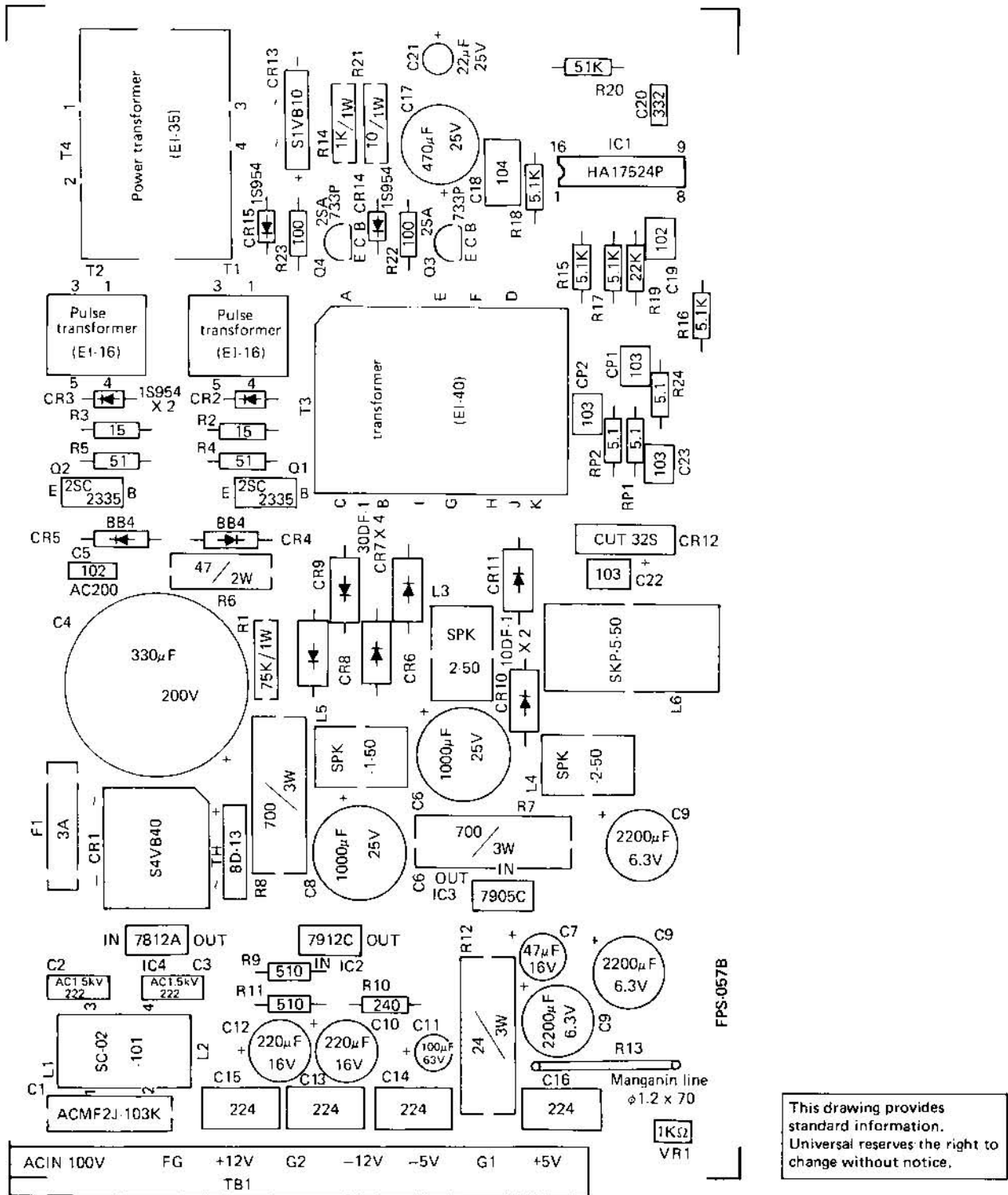

Fig. 20 Power Circuit Board

UNIVERSAL

Item No.	Q'ty	Description
2J-103	1	Mylar Capacitor
224	4	" 50V
332	1	" "
104	1	" "
103	4	" "
102	1	" "
222	2	Ceramic Capacitor AC1.5KV
102	1	" AC200V
330	1	Electrolytic 200V
1000	2	" 25V
470	1	" "
22	1	" "
220	2	" 16V
47	1	" "
2200	3	" 6.3V
100	1	" "
S4VB40	1	Silicon Stack
S1VB10	1	"
CTU-32S	1	"
1S953	4	Silicon Diode
SR1K-400	2	"
30DF-1	4	"
10DF-1	2	"
SC-02-101	1	Choke Coil
SN-8D-500	2	"
SKP-1-50	1	"
SKP-5-50	1	"
HA17524P	1	IC
-7905C	1	"
7912	1	"
7812	1	"
2SC2335	2	Transistor
2SA733P	2	"

Rating	Q'ty	Description
700Ω	2	Oxide Film Resistance 3B
24Ω	1	" 3B
47Ω	1	" 2B
75KΩ	1	" 1B
1KΩ	1	" "
10Ω	1	" "
5.1Ω	3	Carbon Resistance ¼W
15Ω	2	" "
51Ω	2	" "
100Ω	2	" "
240Ω	1	" "
510Ω	2	" "
5.1KΩ	4	" "
22KΩ	1	" "
51KΩ	1	" "

Misc

Name	Q'ty	Description
VR	1	1KΩ
Manganin Line	70m/m	
Output Transformer	1	
Pulse Transformer	2	
Power Transformer	1	
Thermistor	1	8D-13
Fuse	1	3A

UNIVERSAL

WIRING DIAGRAM (CONNECTOR)

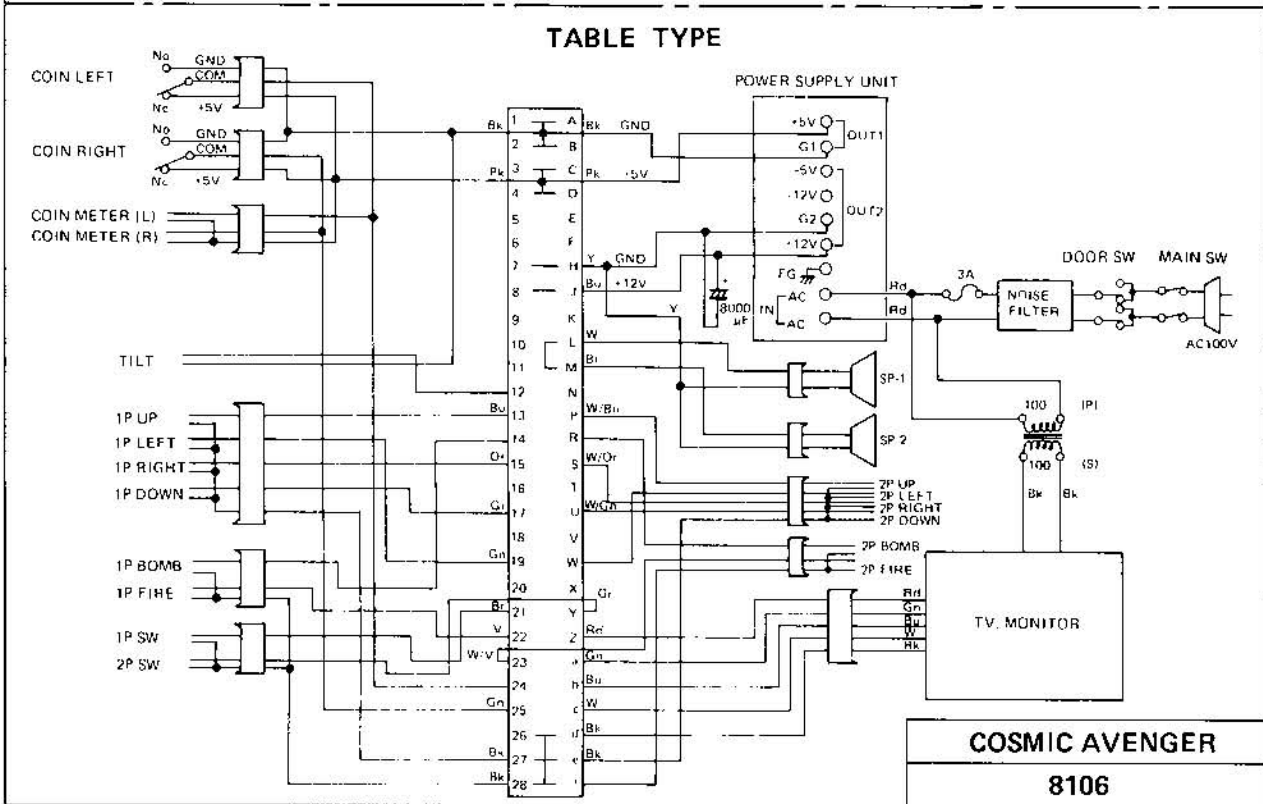
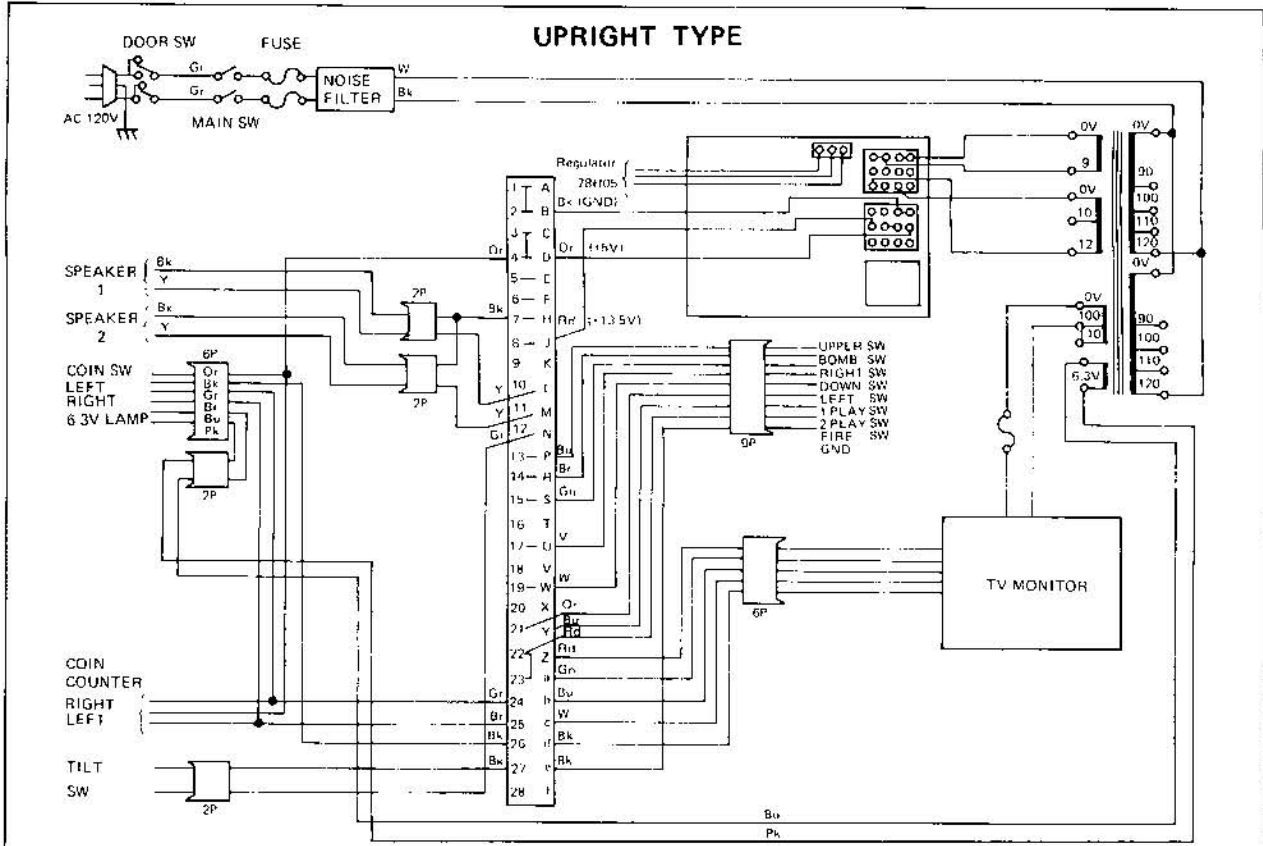

SCHEMATIC DIAGRAM (20" color)

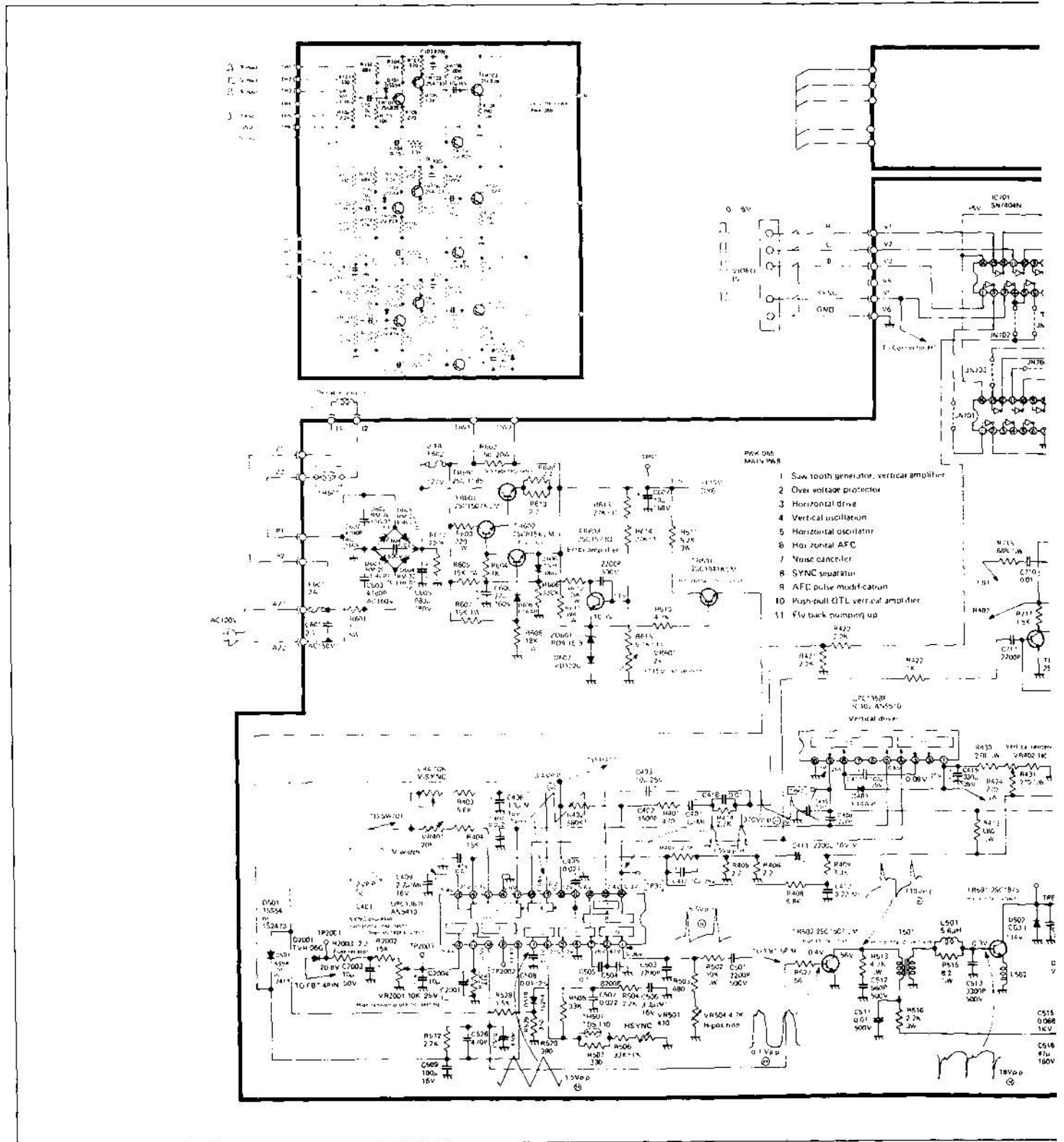

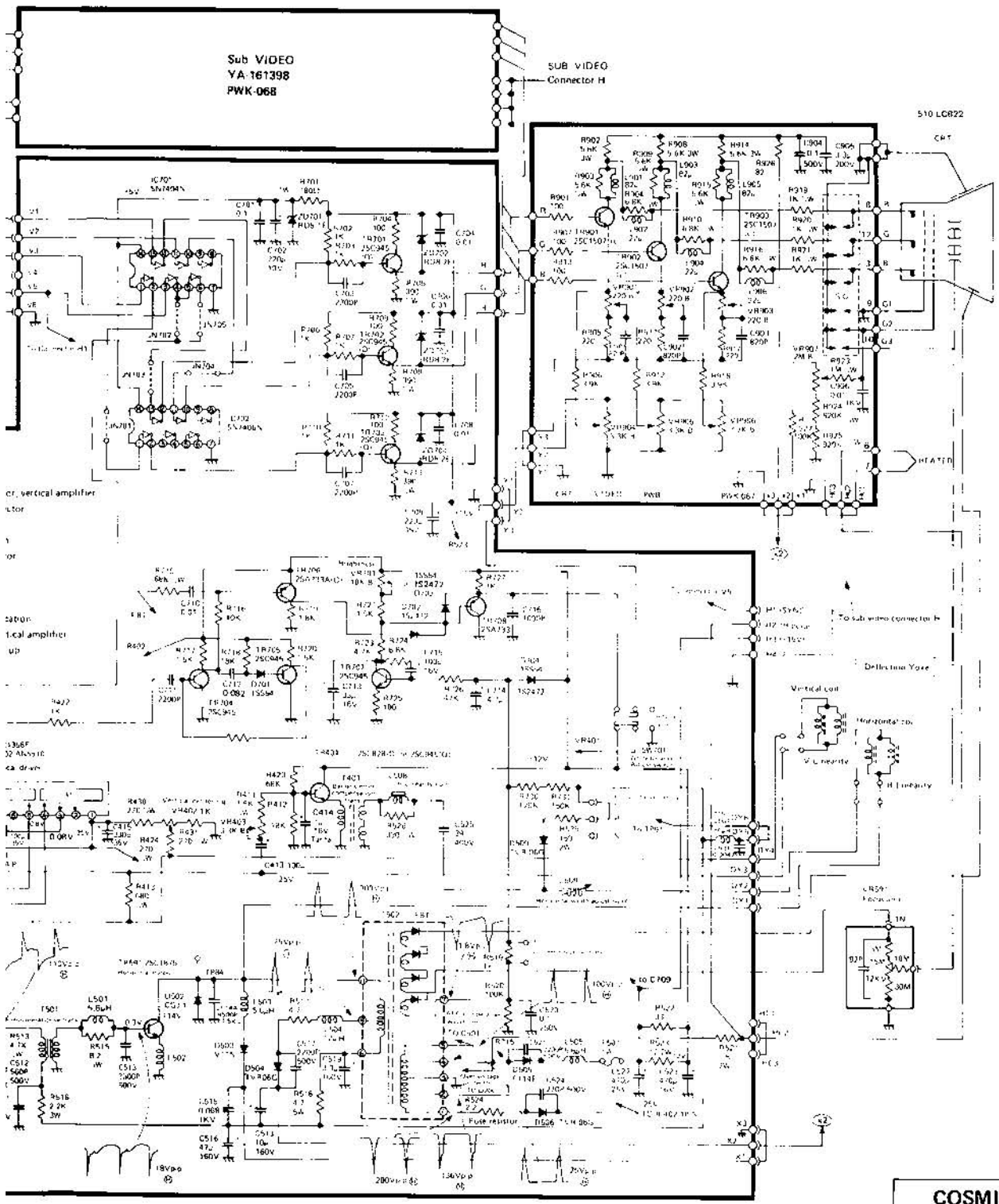

COSMIC AVENGER
8106

SCHEMATIC DIAGRAM (20" color)

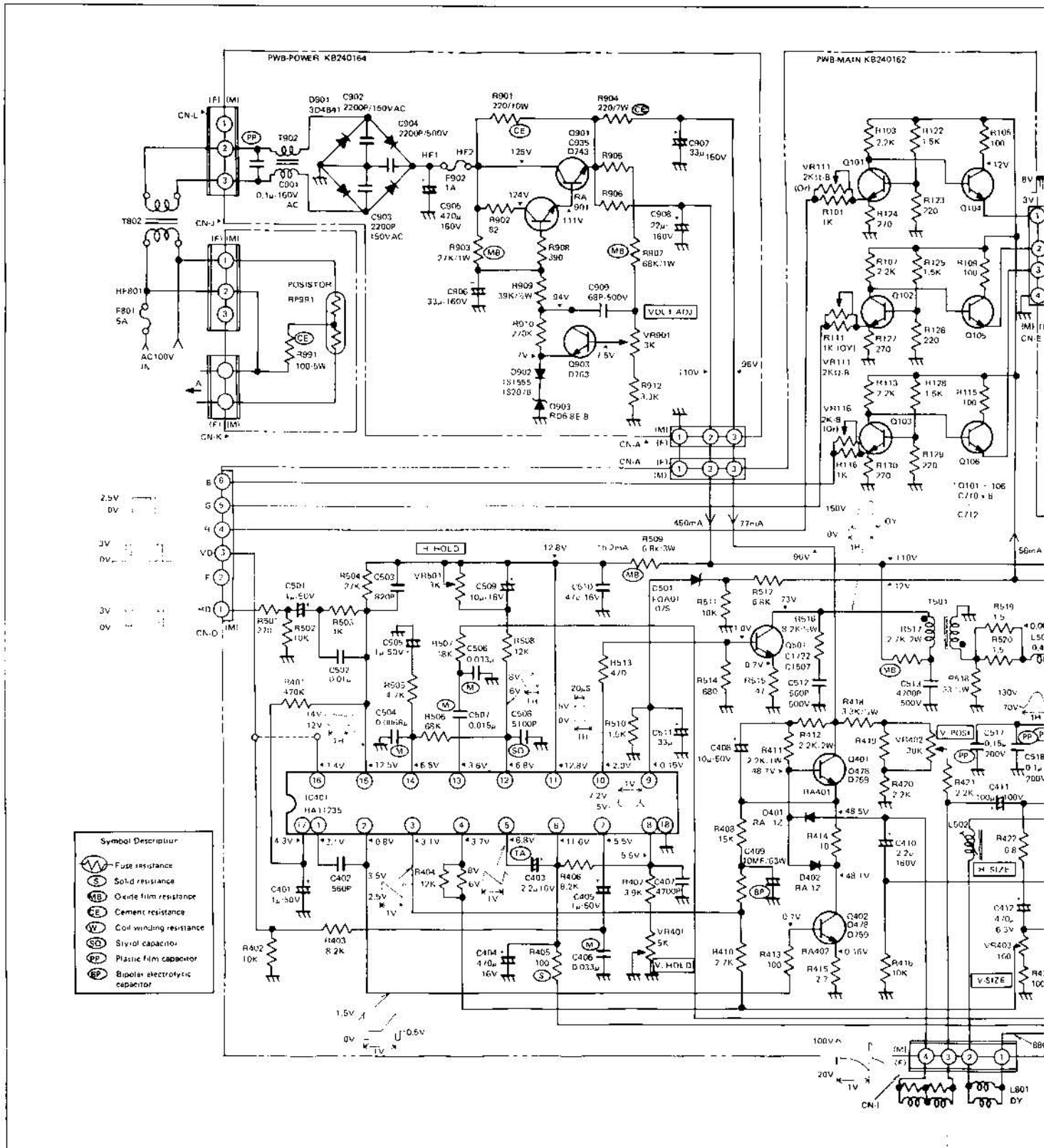

SCHEMATIC DIAGRAM (14" color)

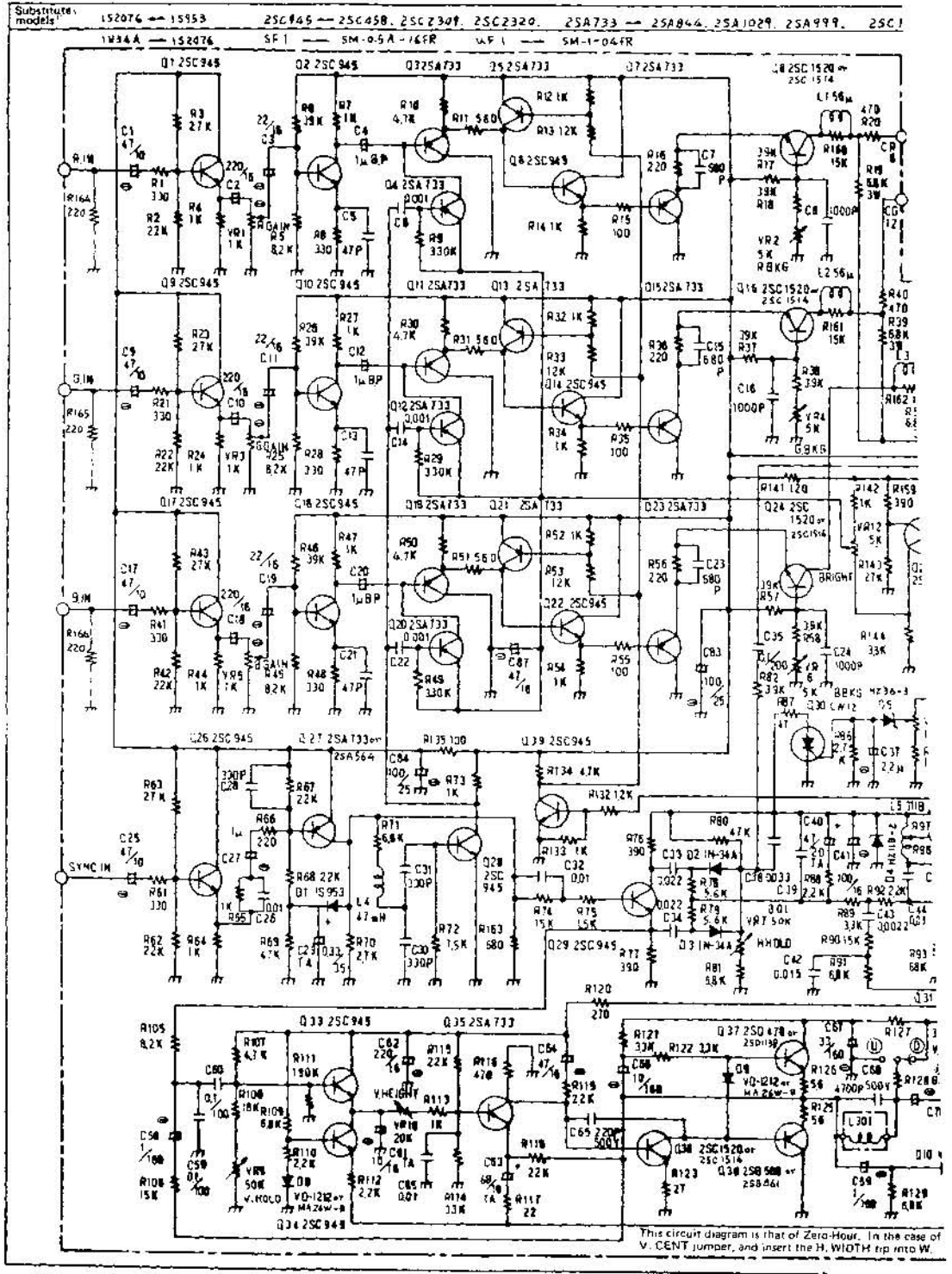

5A1029, 25A999, 25C1514 → 25C1520, 25C1506.

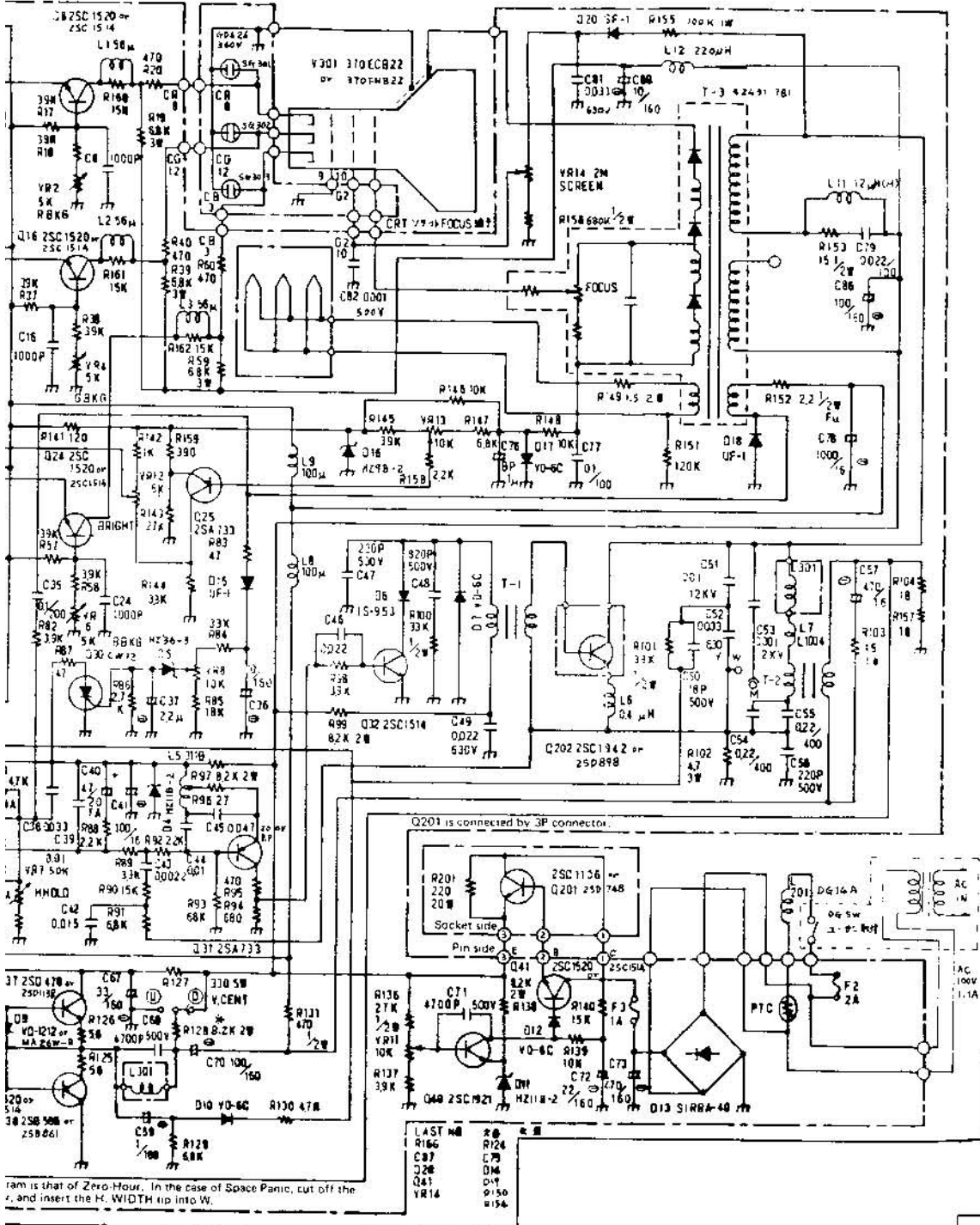

COSMIC AVENGER

8106

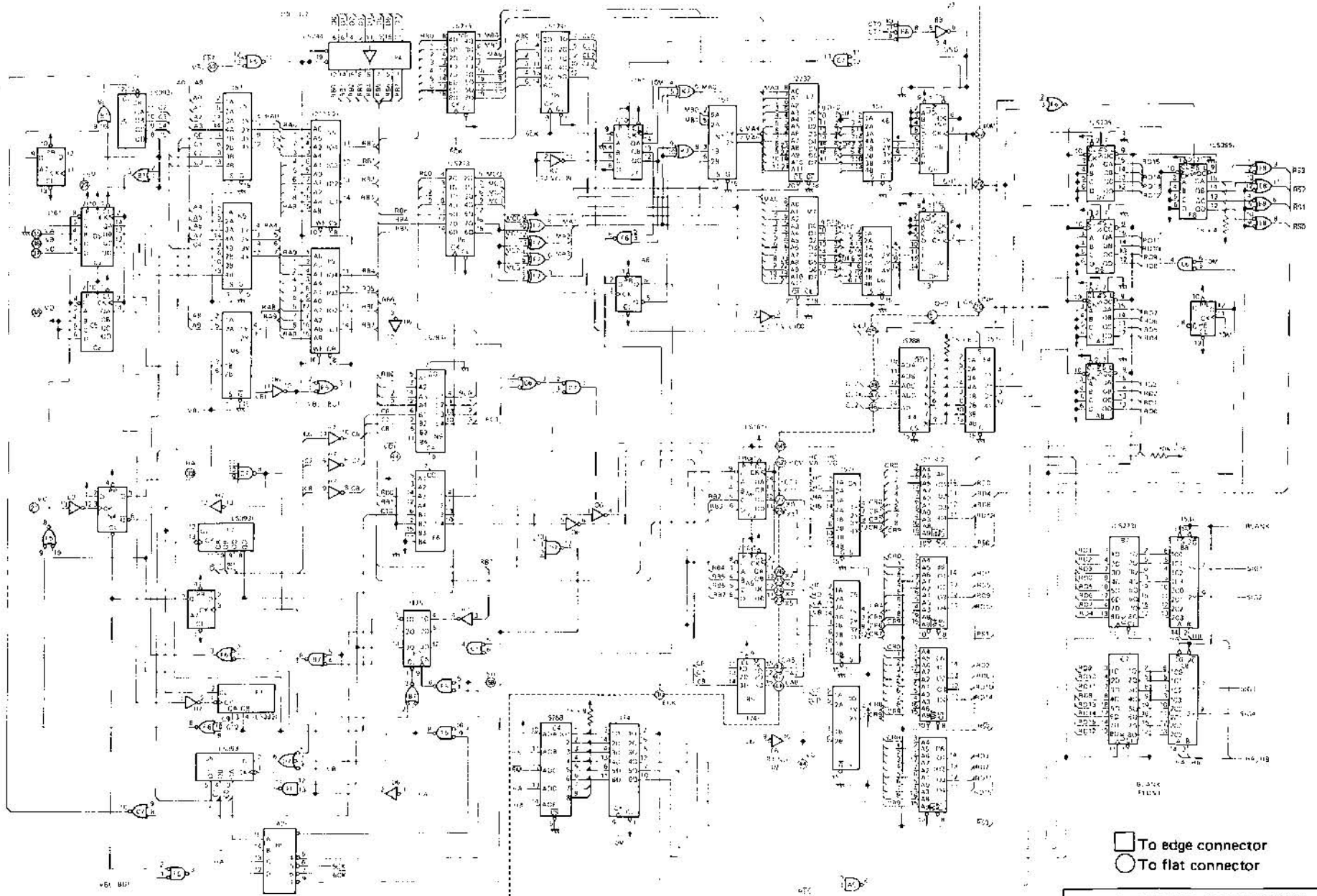

- To edge connector
- To flat connector

COSMIC AVENGER
8106

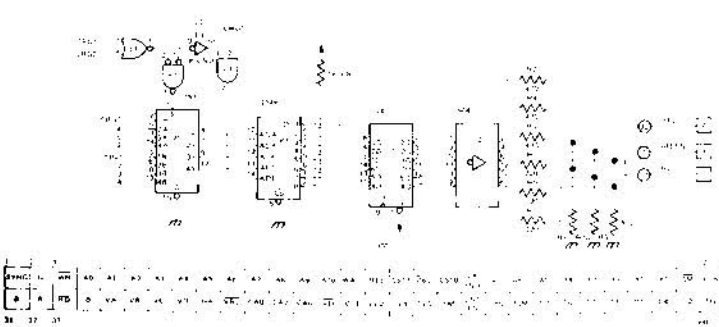
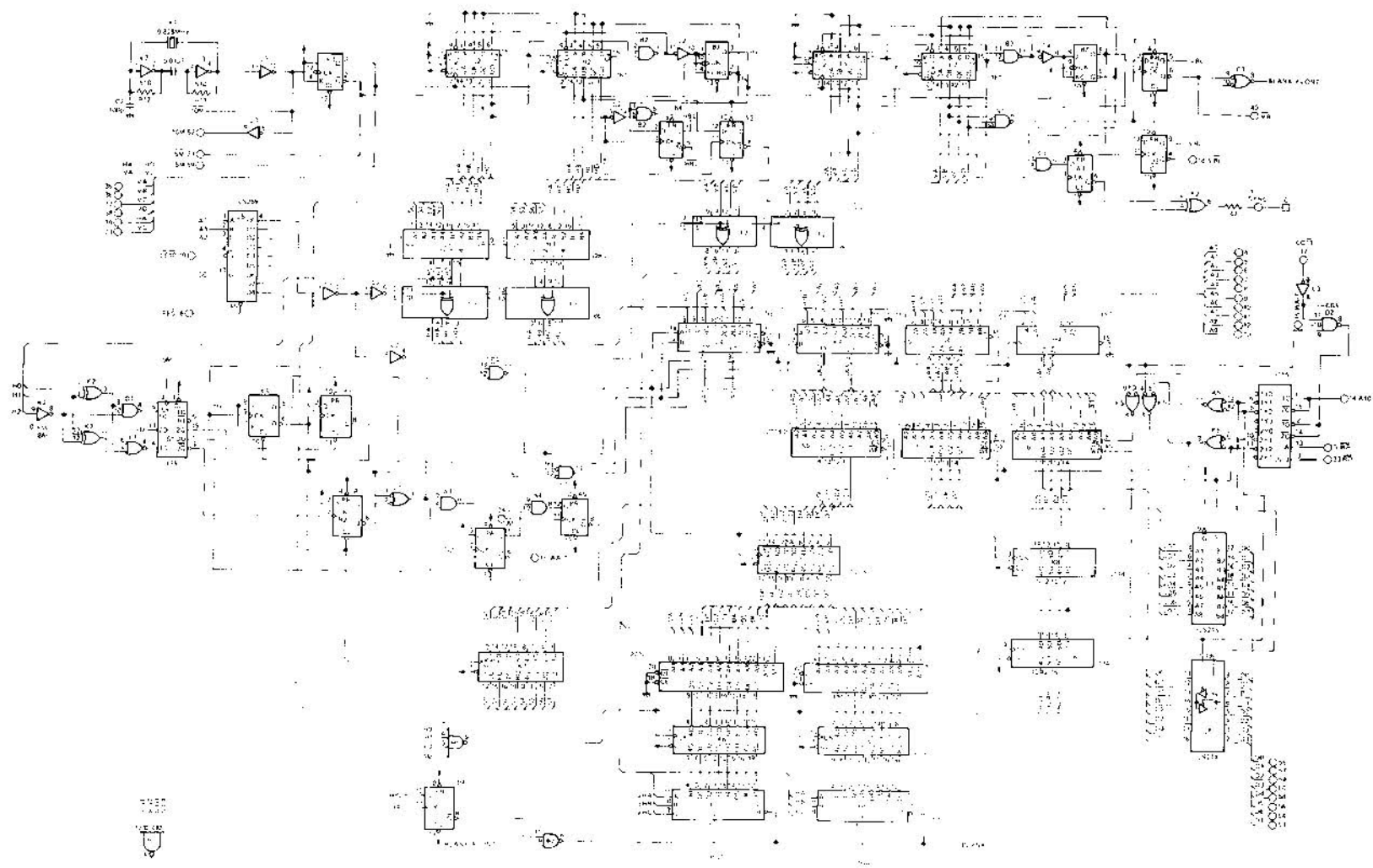

TOP VIEW

POWER SOURCE BLOCK DIAGRAM (Table type)

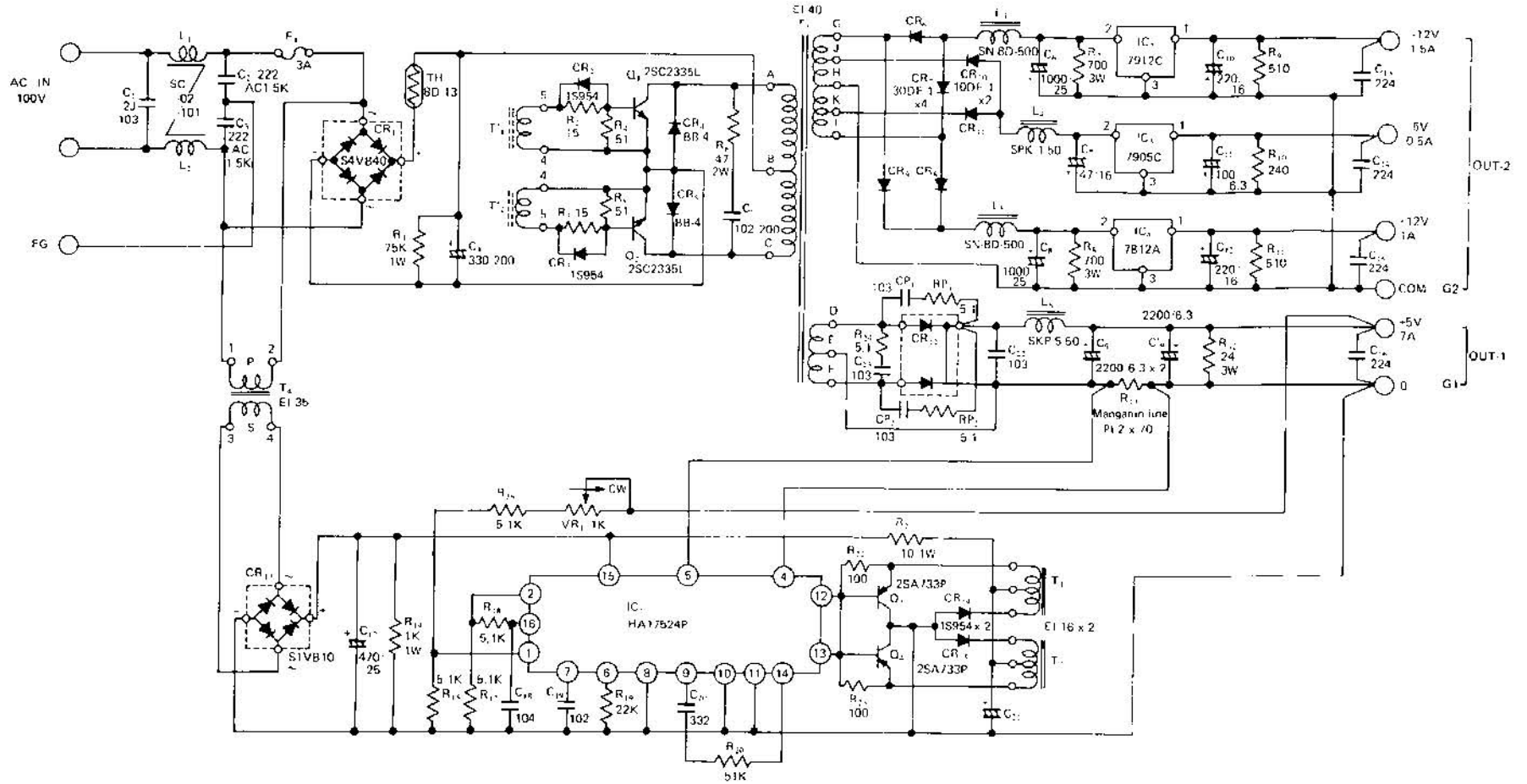

COSMIC AVENGER

8106

POWER SOURCE BLOCK DIAGRAM (Upright type)

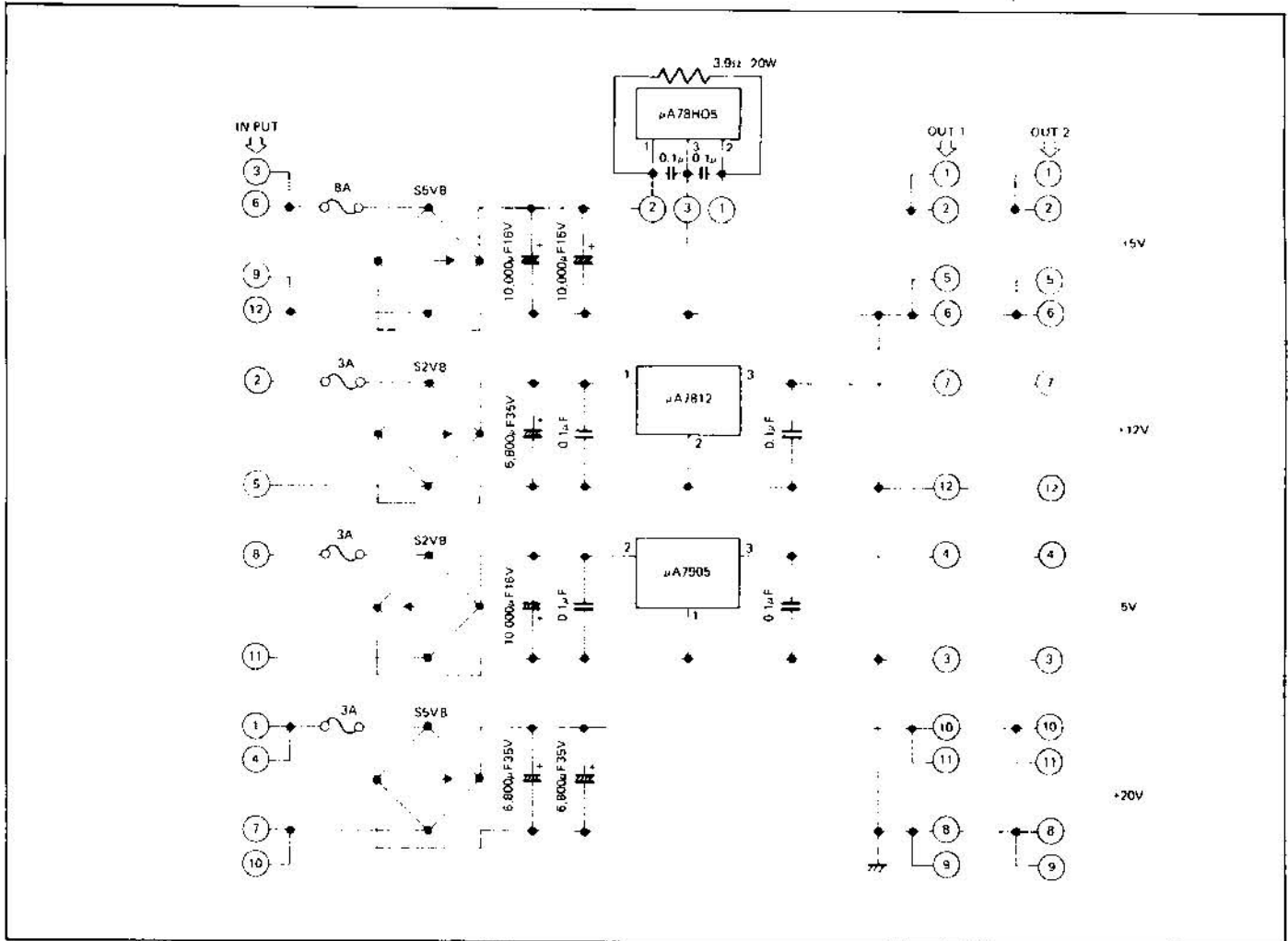

BLOCK DIAGRAM

