

1 ST PRINTING - DC

# SEGA



# DAYTONA<sup>TM</sup> USA

SPECIAL  
OWNER'S MANUAL

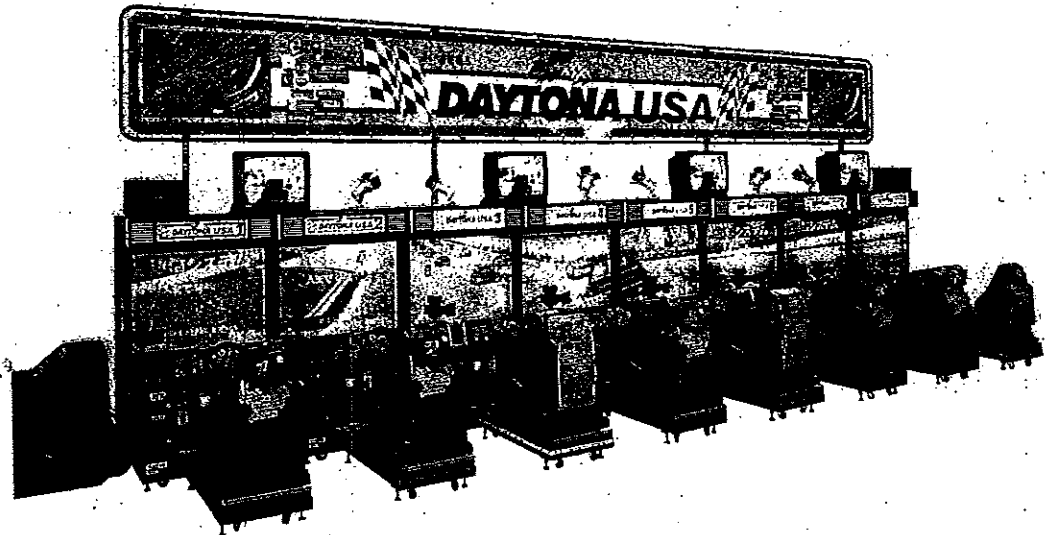

## SEGA ENTERPRISES, LTD.

MANUAL NO. 420 - 6124 - 06

---

---

## TABLE OF CONTENTS

---

---

INTRODUCTION OF OWNER'S MANUAL		
1.	HANDLING PRECAUTIONS .....	1
2.	PREVENTION OF COUNTERFEITING AND CONVERSION .....	2
3.	PRECAUTIONS CONCERNING INSTALLATION LOCATION .....	3
4.	NAME OF PARTS .....	4 ~ 6
5.	ACCESSORIES .....	7 ~ 11
6.	METHOD OF INSTALLATION AND ASSEMBLY .....	12 ~ 37
6-1	PREPARATIONS PRIOR TO INSTALLATION AND ASSEMBLY .....	12
6-2	COMPRESSOR .....	13 ~ 15
6-3	PTV .....	16 ~ 21
6-4	FRONT CABI .....	22 ~ 25
6-5	REAR CABI .....	26 ~ 27
6-6	MONITORS AND SPEAKERS .....	28 ~ 30
6-7	BANNER .....	31 ~ 34
6-8	CONTROL TOWER .....	35 ~ 36
6-9	CONNECTION TO INDOOR POWER SUPPLY .....	37
7.	PRECAUTIONS TO BE HEEDED WHEN TURNING THE POWER ON. ....	38 ~ 39
7-1	PROCEDURE FOR TURNING THE POWER ON .....	38
7-2	SEQUENTIAL ORDER OF THE ACTUATION AT THE TIME OF TURNING THE POWER ON .....	38 ~ 39
7-3	FUNCTIONING CHECK SHEET .....	39
8.	PRECAUTIONS TO BE HEEDED WHEN IN OPERATION .....	40 ~ 41
9.	HOW TO PLAY .....	42 ~ 43
10.	EXPLANATION OF TEST AND DATA DISPLAY .....	44 ~ 60
10-1	SWITCH UNIT .....	45
10-2	TEST MODE .....	46
10-3	BOOKKEEPING .....	47 ~ 48
10-4	GAME SYSTEM .....	49
10-5	COIN ASSIGNMENT .....	50 ~ 51
10-6	INPUT TEST .....	52
10-7	OUTPUT TEST .....	53
10-8	DRIVE BD TEST .....	54 ~ 57
10-9	SOUND TEST .....	58
10-10	TGP TEST .....	59
10-11	MEMORY TEST .....	59
10-12	BACKUP RAM CLEAR .....	60
11.	CONTROL TOWER .....	61 ~ 66
11-1	SERVICE PANEL .....	61 ~ 62
11-2	POWER AMPLIFIER .....	63
11-3	DIP SW .....	64 ~ 65
11-4	CHANGING THE DIRECTION OF THE CONTROL TOWER'S SERVICE PANEL .....	66
12.	AIR DRIVE SYSTEM .....	67 ~ 71
12-1	COMPOSITION OF AIR DRIVE SYSTEM .....	68
12-2	MAINTENANCE OF AIR DRIVE SYSTEM .....	69
12-3	GREASING .....	70
12-4	ADJUSTING THE AIR DRIVE SYSTEM .....	71
13.	CONTROL PANEL (HANDLE MECHANISM) .....	72 ~ 73
13-1	ADJUSTMENT AND REPLACEMENT OF VOLUME .....	72 ~ 73
13-2	GREASING .....	73
14.	4 SPEED SHIFTER .....	74 ~ 76
14-1	REMOVING THE SHIFTER .....	74
14-2	REPLACING THE SWITCH .....	75
14-3	GREASING .....	76

15. ACCELERATOR & BRAKE .....	76~77
15-1 ADJUSTMENT AND REPLACEMENT OF VOLUME .....	77
15-2 GREASING .....	77
16. CCD CAMERA ADJUSTMENTS .....	78~79
17. CIRCUIT PROTECTOR AND FUSE .....	80~81
18. REPLACEMENT OF FLUORESCENT LAMP, ECT. ....	82
19. COIN SELECTOR .....	83
20. PROJECTOR .....	84~87
20-1 CLEANING THE SCREEN .....	84
20-2 HITACHI PROJECTOR ADJUSTMENT .....	85
20-3 MITSUBISHI PROJECTOR ADJUSTMENT .....	86~87
21. PERIODIC CHECK .....	88
22. TROUBLESHOOTING .....	89~90
23. GAME BOARD .....	91~93
23-1 TAKING OUT THE BOARD .....	91~92
23-2 COMPOSITION OF GAME BOARD .....	93
23-3 INPUT AND OUTPUT RELATIONS .....	93
24. DESIGN RELATED PARTS .....	94~95
25. PARTS LIST .....	96~177
26. WIRE COLOR CODE TABLE .....	178
27. WIRING DIAGRAM .....	179~185
28. PIPING DIAGRAM .....	186

### <SPECIFICATIONS>

The DAYTONA USA SPECIAL has 2 different types, i.e., 4P type and 8P type. The following Specifications data applies to the machines which utilizes the compressors used in Japan. As regards large-sized compressors, various restrictions apply depending on each country. Therefore, compressors meeting the specific country's laws and regulations may have to be used in foreign countries. Note that the data will vary accordingly.

Also, the required installation space and height herein stated apply to the cases where the machine is assembled to the SEGA Specifications. Installation positions for some of the component units are changeable in a manner so as to meet the requirements of the installation locations (layout of the installation locations, height of ceiling, etc.).

\* COMPRESSOR : 965 mm (Width) × 757 mm (Depth) × 1,030 mm (Height)  
 Approx. 205 kg (Weight)

CONTROL TOWER : 760 mm (Width) × 600 mm (Depth) × 940 mm (Height)  
 Approx. 97 kg (Weight)

Maximum current for 4P type	
Space required for the main portion :	4,600 (W) × 2,510 mm (D)
Height :	2,400 mm (3,065~3,600 mm when the Banner is attached)
Total Weight :	Approx. 1,540 kg
Power consumption :	5.5 KW
Max. power current :	27 A (AC 200 V), 25 A (AC 220 V), 23 A (AC 240 V)

Maximum current for 8P type	
Space required for the main portion :	9,200 (W) × 2,510 mm (D)
Height :	2,400 mm (3,065~3,600 mm when the Banner is attached)
Total Weight :	Approx. 3,070 kg
Power consumption :	7.0 KW
Max. power current :	35 A (AC 200 V), 32 A (AC 220 V), 30 A (AC 240 V)

CAUTION: The above values apply when the compressors used in Japan are utilized.

## INTRODUCTION OF THE OWNER'S MANUAL

SEGA ENTERPRISES, LTD., supported by its high electronic technology of LSIs, microprocessors, etc. and a wealth of experience, has for more than 30 years been supplying various innovative and popular game machines to the world market. This Owner's Manual is intended to provide detailed descriptions together with all the necessary information covering the general operation of electronic assemblies, electromechanicals, servicing control, spare parts, etc. as regards

**DAYTONA USA SPECIAL**, a new SEGA product.

This manual is intended for those who have knowledge of electricity and technical expertise especially in ICs, CRTs, microprocessors, etc. Carefully read this manual to acquire sufficient knowledge before working on the machine. Should there be a malfunction, non-technical personnel should under no circumstances touch the interior system. Should such a case arise, contact our Main Office or the closest branch office listed as follows:

As regards the compressors and 25 inch monitors used for this machine, refer to the attached Instruction Manuals as applicable.

SEGA ENTERPRISES, INC. (U.S.A.)/CUSTOMER SERVICE  
45133 Industrial Drive, Fremont, California 94538, U.S.A.  
Phone : (415) 802-3100  
Fax : (415) 802-1754

SEGA AMUSEMENTS EUROPE LIMITED/AMUSEMENT MACHINE SALES DIVISION  
Unit 2 Industrial Estate, Leigh Close, New Malden, Surrey KT3 3NL, England  
Phone : (081) 336-2256  
Fax : (081) 336-1715

SEGA SOUTHERN EUROPE LIAISON OFFICE  
Calle Vallellano, 19-23, 1° A, 37008-Salamanca, Spain  
Phone : (923) 265893  
Fax : (923) 265913



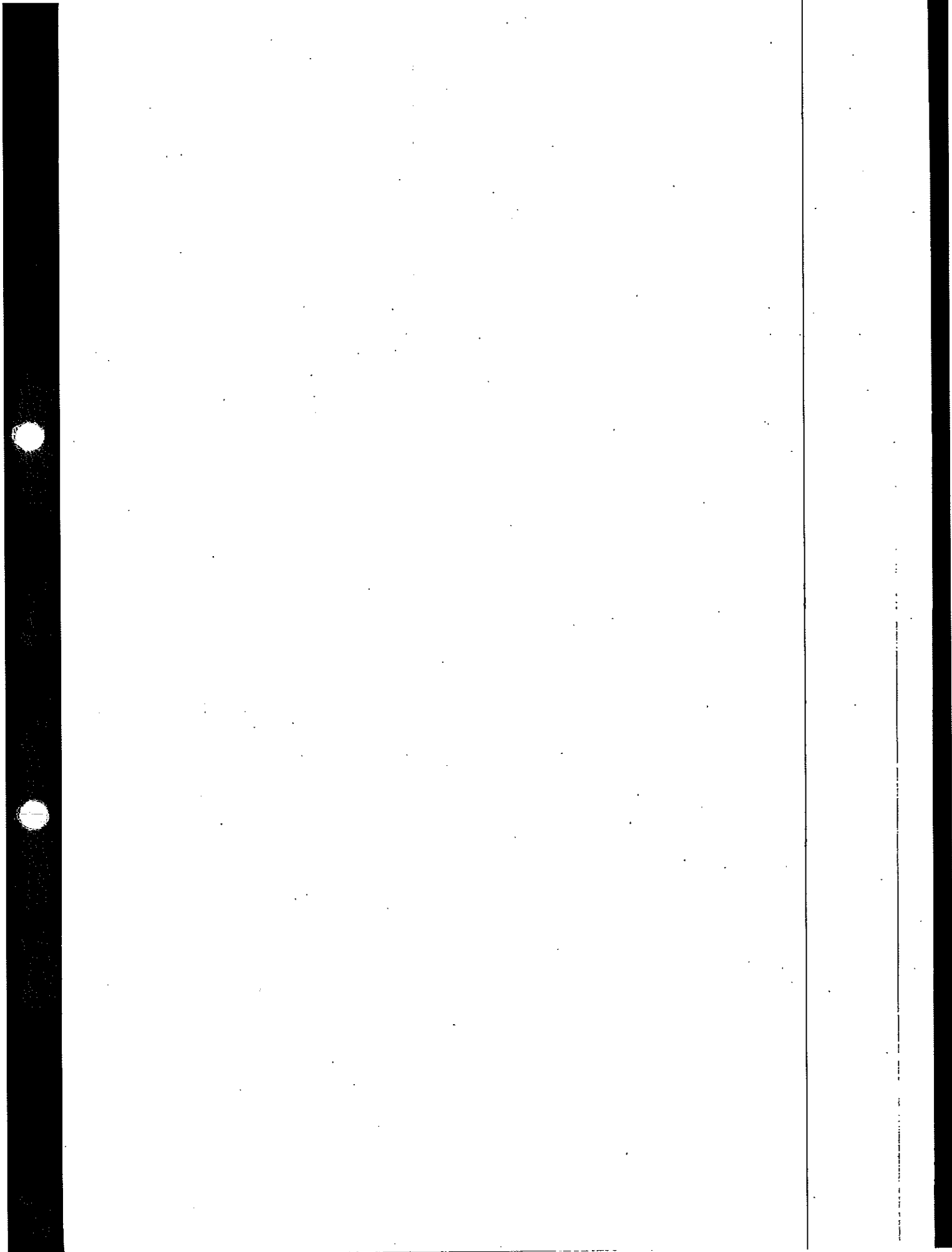

## 1. HANDLING PRECAUTIONS

When installing or inspecting the machine, be very careful of the following points and pay attention to ensure that the player can enjoy the game safely.

- Be sure to turn the power off before working on the machine.
- To insert or pull out the plug quickly is dangerous.
- It is necessary to make sure that the power cord or the grounding wire is not exposed on the surface (floor, ground, etc.) in a manner so as to be dangerous. Make sure that grounding connections are made safely at the position where so specified.
- Do not use any fuse that does not meet specified rating.
- Make complete connections for the IC board and other connectors. Insufficient insertion is very dangerous.
- The operating (ambient) temperature range is from 5°C to 40°C.
- When cleaning the CRT surfaces, use a soft, dry cloth. Do not apply chemicals such as thinner, benzene, etc.

After making sure that there is no irregularity, turn the power ON. Concerning the procedure for turning the power ON, refer to Section 7.

### CONCERNING THE PROJECTION DISPLAY:

A PROJECTION DISPLAY is used for this machine. The PROJECTION DISPLAY's screen is susceptible to damage and therefore, when cleaning it, pay careful attention. For details, refer to Section 20.

## 2. PREVENTION OF COUNTERFEITING AND CONVERSION

### ◆ LABELLING

To prevent counterfeits and conversions, the following labels are put on all the SEGA products. When handling such goods, be sure to confirm the labels. They are used to prevent illegal acts such as the unauthorized copying of the products and the printed circuit boards thereof or carrying on business by manufacturing similar merchandise or by converting, selling or using such products or printed circuit boards.

ORIGINAL SEAL  
The following seal is put on the  
machines manufactured by SEGA.



### ◆ COPYRIGHT NOTICE

This SEGA product has the copyright notice as follows:

© SEGA 1994

This signifies that this work was disclosed in 1994 and is the property of SEGA ENTERPRISES, LTD.

### 3. PRECAUTIONS CONCERNING INSTALLATION LOCATION

■ As regards the door opening to the installation location:

At the time of shipment, this machine is disassembled into main component units (there are 8 kinds of large component units for the 4P type). The width of the opening for the units to pass through should be in excess of 90 cm.

■ Floor space of installation location

The floor space required for the installation of this machine is as described in the preceding page. However, when considering the assembly work and the after-assembly operation and safety measures, the 4P type needs the floor space of approx. 5.2 m in width and approx. 2.6 m in depth. The 8P type needs approx. 9.8 m in width and 2.6 m in depth.

■ Floor strength

The total weight of the 4P type is approx. 1,840 kg, and that of the 8P type is approx. 3,370 kg. Pay careful attention to the allowable load on the floor of the machines' installation location. The machine is driven by means of compressor. During its operation, the machine is subject to vibration and low frequency due to the compressor motor. Therefore, pay attention to the effect caused to the neighbors.

■ Height of Ceiling

The ceiling height required by this machine is 2.4 m at the minimum. The ceiling height required by the standard machines for the 4P type is approx. 3.1 m and for the 8P type, approx. 3.1 m.

■ Power supply

The operation of this machine for the 4P type requires a power supply of 3-phase 200V 50A (in the AC 220V~240V area, that of 3-phase 220V~240 V 45 A is required), and for the 8P type, requires that of 3-phase 200V 150 A (in the AC 220V~240V area, that of 3-phase 220V~240V 75A). Due to the high voltage and high capacity, an exclusively used power supply should be available. When using an extension cable, be sure to utilize the one meeting the specified rating. Also, provide one earth terminal for each machine unit.

■ Lighting

This machine is equipped with the EMERGENCY STOP SW to allow the Attendant to stop the cockpit movements. Sufficient lighting should be provided in a manner so as to allow the Attendant to detect danger and to promptly respond to such status.

The DAYTONA USA SPECIAL is an indoor game machine. Under no circumstances install it outside. Even indoors, avoid installing in places mentioned below so as to ensure proper usage :

- Places subject to rain or water leakage, or condensation due to humidity.
- In the proximity of an indoor swimming pool and/or shower.
- Places subject to direct sunlight.
- Places subject to heat sources from heating units, etc., or hot air.
- Vicinity of highly inflammable/volatile chemicals or hazardous matter.
- Sloped surfaces.
- Vicinity of anti-disaster facilities such as fire exits and fire extinguishers.
- Places subject to any type of violent impact.
- Dusty places.

#### 4. NAME OF PARTS

This Figure shows a standard unit layout. In a manner to match the conditions (space situation, ceiling height, etc.) of the location, the installation positions of the CONTROL TOWER, BANNER, etc. are variable.

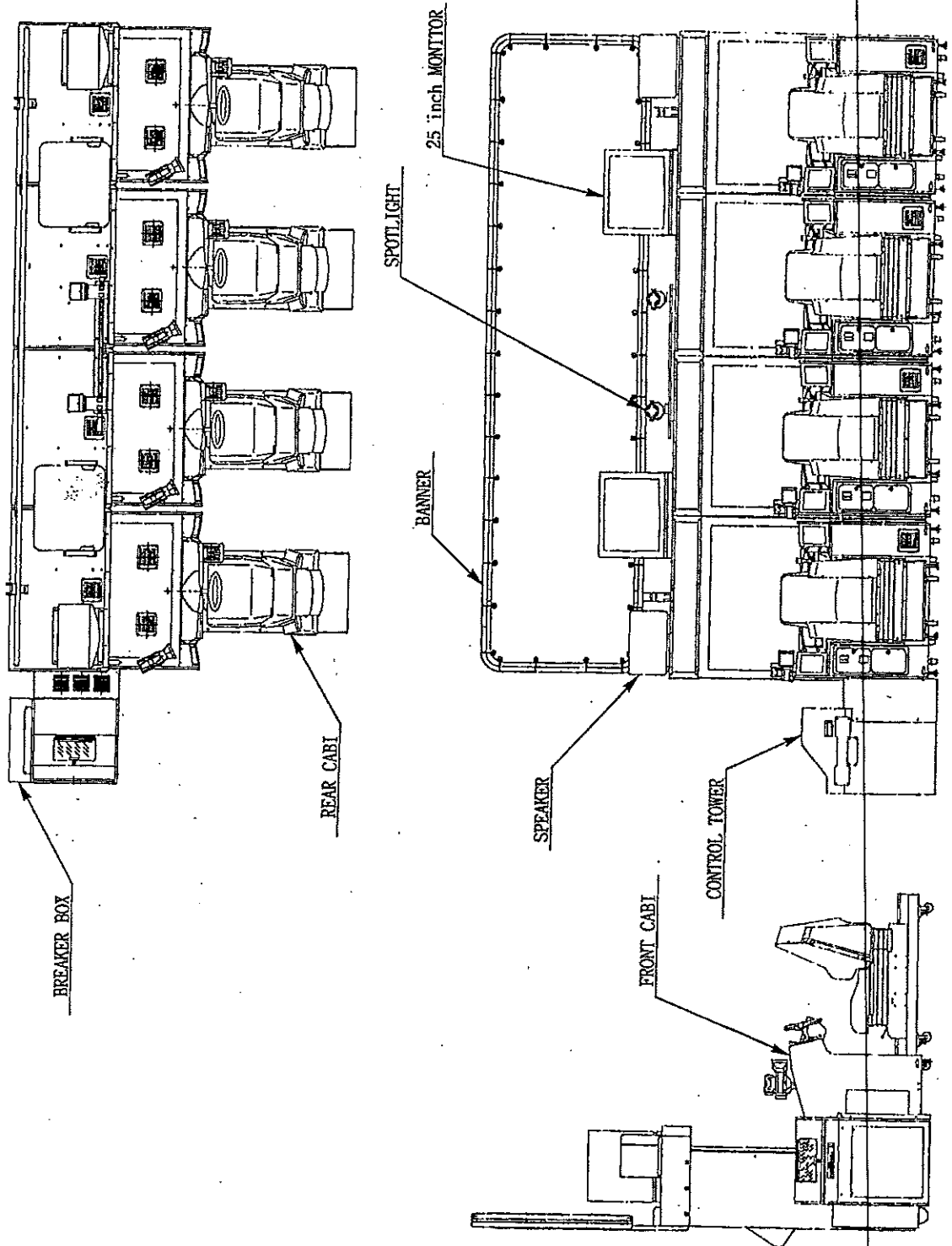

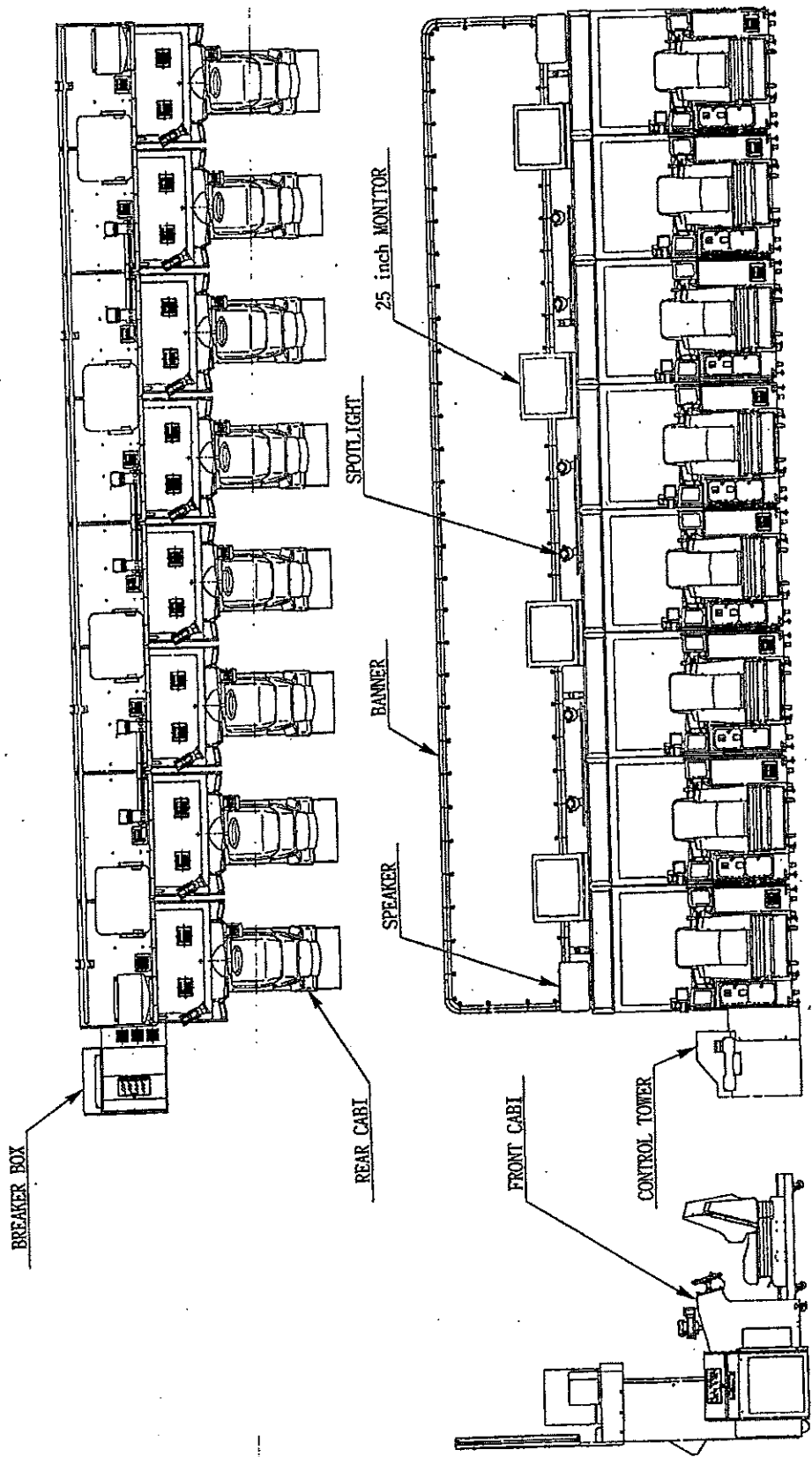

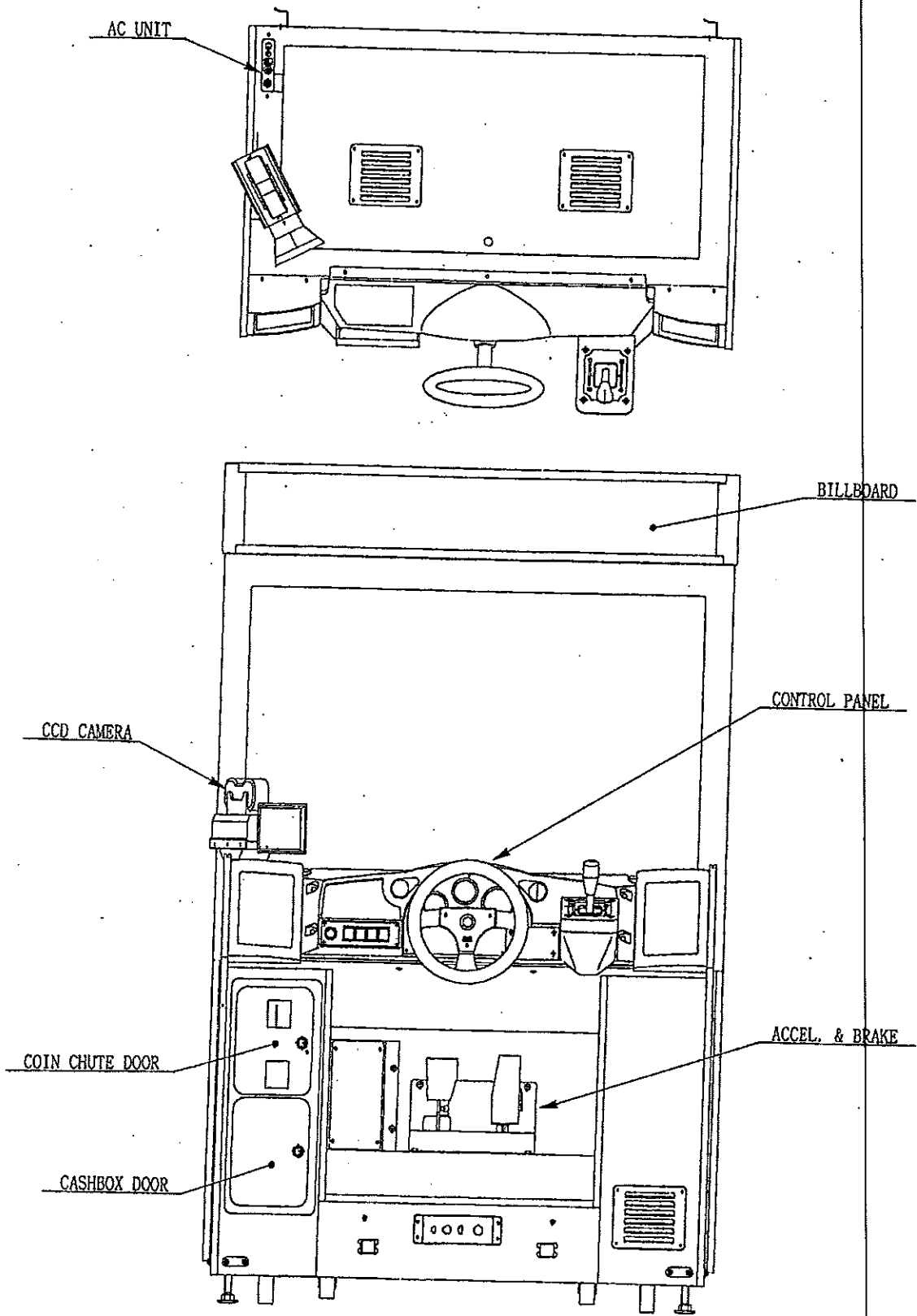

Note: "ACCEL." refers to the ACCELERATOR.

## 5. ACCESSORIES

At the time of shipment, this machine is disassembled into main units after checking upon completion of assembly. Prior to assembling, check each of the units transported and ascertain the quantity. The number shown in [ ] under each Fig. indicates the quantity. The number in ( ) shows the quantity for the 4P type.

### CHECK ITEMS

- (1) Check to see if there is any defects, indented portions, etc. on the external surfaces.
- (2) Check for any damage caused to the leg adjusters and casters.
- (3) Check to see if the wiring connectors are securely inserted. Unless the connectors are inserted in the correct direction, they won't fit properly. Therefore, be sure not to forcibly try to insert it.
- (4) Make sure that all of the IC's of the IC BD. are securely inserted into the socket.
- (5) Check to see if there is any crack or indentation in the power cord insulator.
- (6) Are there adequate fuses provided?
- (7) Is each of the electrical equipment (such as monitors, speakers, etc.) firmly secured? Are the earth wires adequately connected?
- (8) Do the machines' rated voltages and rated frequencies shown on the nameplate match with those of the installation location?
- (9) Are all of the accessories available?

Note: Depending on the countries, the COMPRESSOR designated by SEGA can not be used. In that case, prepare the COMPRESSOR meeting the requirements of that particular country's laws and regulations.

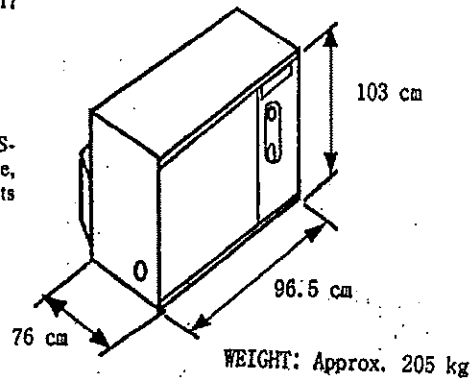

4 CASTERS  
4 LEG ADJUSTERS

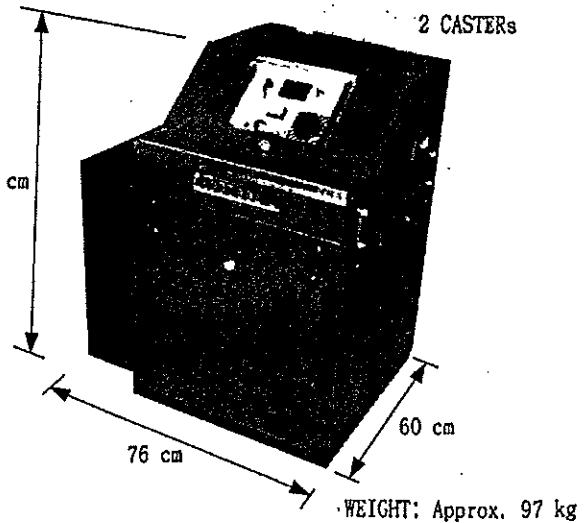
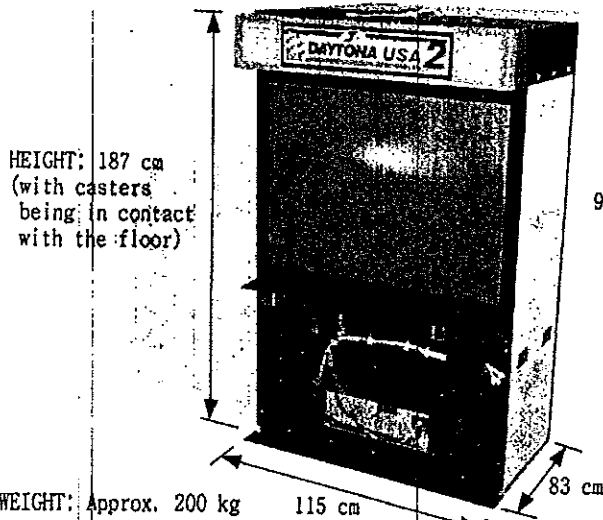



4 CASTERS  
4 LEG ADJUSTERS

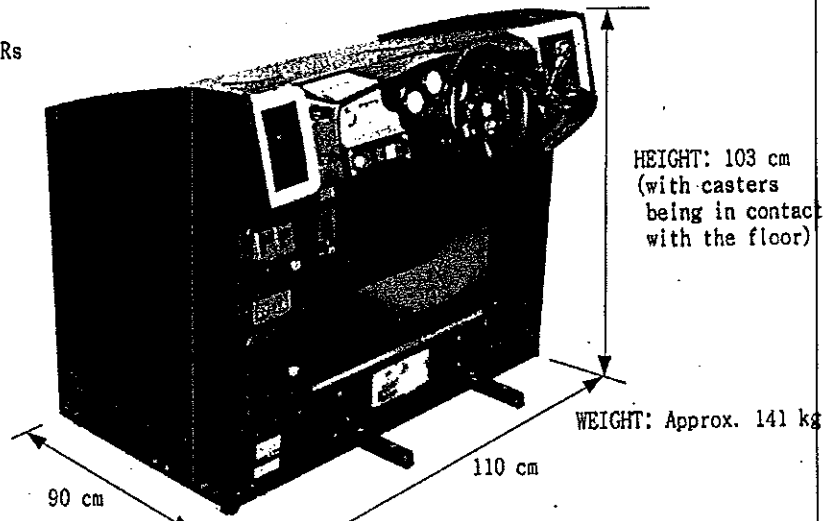

Fig. 5.4 FRONT CABI[8(4)]

4 CASTERS  
4 LEG ADJUSTERS

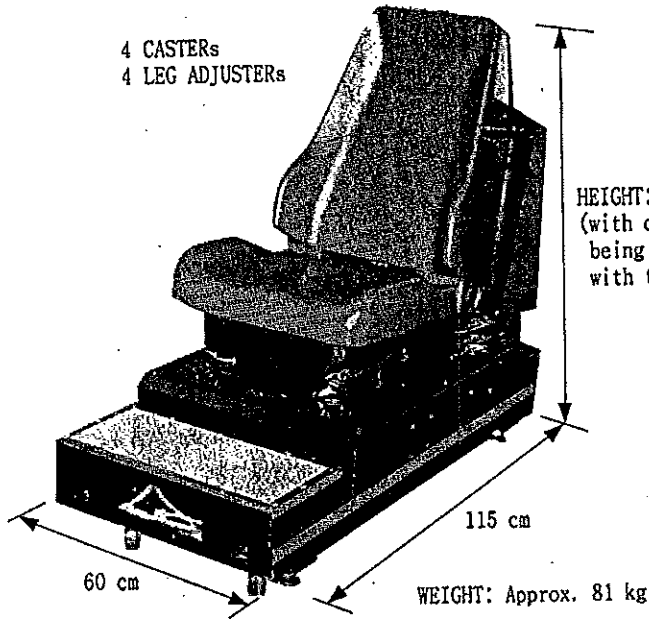

Fig. 5.5 REAR CABI[8(4)]

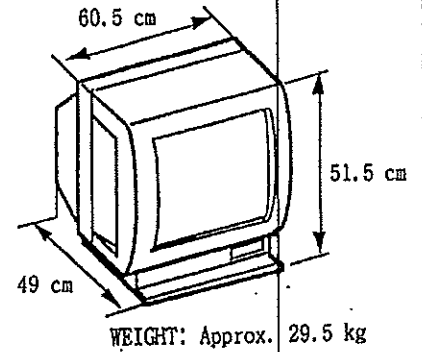

Fig. 5.6 25 inch MONITOR[4(2)]

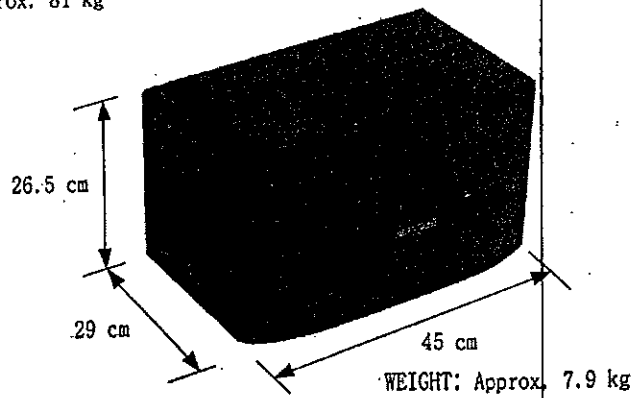

Fig. 5.7 SPEAKER[2]

□ OPTIONAL PARTS

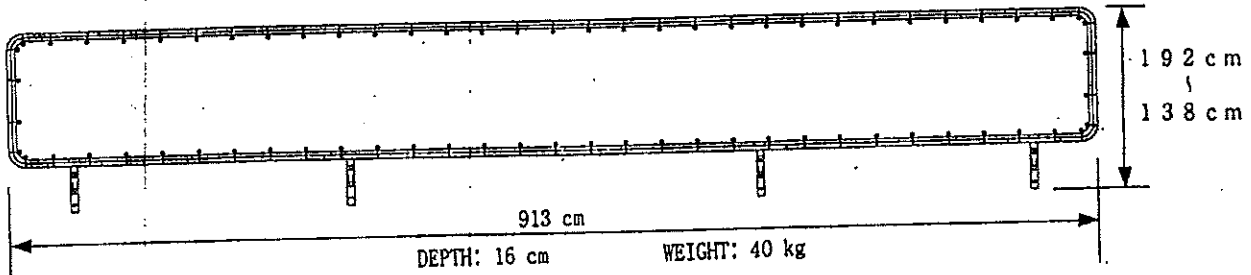

Fig. 5.8a BANNER FOR 8P type

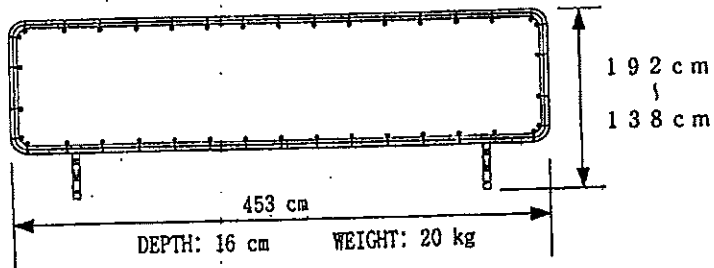

Fig. 5.8b BANNER FOR 4P type

- The height of the Banner is changeable within the range of 138 cm ~ 192 cm in increments of 13.5 cm.
- Three Spotlights are required for the 8P type and one for the 4P type.

**TABLE OF FASTENERS (SCREWS, BOLTS, NUTS, etc.)**

TABLE 5.1

The quantities in the parentheses apply for the 4P type.

PART No.	QTY.	DESCRIPTION	USED FOR:
000 - T00408 - 0B	19(11)	M SCR TH BLK M4×8	WIRE COVER B/SIDE LID/ SIDE LID S
000 - T00520 - 0B	108(56)	M SCR TH BLK M5×20	BILLBOARD/ TOWER SPACER/ MASK
030 - 000830 - SB	82(42)	HEX BLT W/S BLK M8×30	JOINT HOLDER/REAR CABI/SPEAKER/CRT SECURING BRKT A, B
030 - 000850 - SB	32(16)	HEX BLT W/S BLK M8×50	REAR CABI
050 - F00500	28(12)	FLG NUT M5	WIRE COVER A
060 - F00800 - 0B	114(58)	FLT WSHR BLK M8	JOINT HOLDER/REAR CABI/SPEAKER/CRT SECURING BRKT A, B
068 - 552016 - 0B	90(48)	FLT WSHR BLK 5.5-20×1.6	BILLBOARD/WIRE COVER A
011 - T03512	106(54)	TAP SCR TH 3.5×12	WIRE DUCT/JOINT BOX
011 - F00312	16(8)	TAP SCR FH 3×12	TIE BELT HOLDER
000 - T00412 - 0B	12(12)	M SCR TH BLK M4×12	DUCT COVER A, B/SP CONNECTOR COVER
000 - F00414	32(16)	M SCR FH M4×14	MASK HOLDER
000 - P00516 - W	104(52)	M SCR PH W/FS M5×16	TOP HOLDER BRKT/SIDE HOLDER BRKT/JOINT BOX
000 - T00525 - 0B	16(8)	M SCR TH BLK M5×25	MASK

**TABLE OF FASTENERS FOR OPTION**

TABLE 5.2

The quantities in the parentheses apply for the 4P type.

PART No.	QTY.	DESCRIPTION	USED FOR:
000 - P00412 - W	6(2)	M SCR PH W/FS M4×12	POWER SUPPLY DUCT
030 - 000616 - SB	48(24)	HEX BLT W/S BLK M6×16	JOINT PIPE/CORNER PIPE/ PIPE A, B
060 - F00600 - 0B	48(24)	FLT WSHR BLK M6	JOINT PIPE/CORNER PIPE/ PIPE A, B
030 - 000820 - SB	8(4)	HEX BLT W/S BLK M8×20	BALL BRKT
SLC - 0006	20(10)	FLT WASHER 8.4-25×2	BALL BRKT BANNER
060 - F00800 - 0B	24(8)	FLT WSHR BLK M8	SPOTLIGHT
030 - 000830 - SB	36(14)	HEX BLT W/S BLK M8×30	SPOTLIGHT/BANNER

## OPTICAL FIBER CABLE & WIRING

TABLE 5.3

PART No.	QTY.	DESCRIPTION	Places of connection /usage
600-6275-0500	8 (4)	ASSY FIBER CABLE $\phi$ 5 500CM	For communication
600-6448-44	1 (1)	WIRE HARN AC200V SPLY 1-4	BREAKER BOX~PTV
600-6448-54	1 (1)	WIRE HARN COMPRESSOR PWR	BREAKER BOX~COMPRESSOR
600-6448-52	1	WIRE HARN SPOTLIGHT	CONTROL TOWER~SPOTLIGHT
600-6448-48	1 (1)	WIRE HARN CCD INPUT 1-4	CONTROL TOWER~CCD CAMERA
600-6448-49	1	WIRE HARN CCD INPUT 5-8	CONTROL TOWER~CCD CAMERA
600-6448-50	1 (1)	WIRE HARN CCD OUTPUT 1-2	CONTROL TOWER~25 inch MONITOR
600-6448-51	1	WIRE HARN CCD OUTPUT 3-4	CONTROL TOWER~25 inch MONITOR
600-6448-66	(1)	WIRE HARN SPOTLIGHT 4P	CONTROL TOWER~SPOTLIGHT
600-6448-45	1	WIRE HARN AC200V SPLY 5-8	BREAKER BOX~PTV
600-6448-53	1	WIRE HARN SPEAKER	CONTROL TOWER~SPEAKER
600-6448-65	(1)	WIRE HARN SPEAKER 4P	CONTROL TOWER~SPEAKER
600-6448-46	1 (1)	WIRE HARN STATES SIGNAL 1-4	CONTROL TOWER~1~4P CABI
600-6448-47	1	WIRE HARN STATES SIGNAL 5-8	CONTROL TOWER~5~8P CABI

## ACCESSORIES

When transporting the machine, make sure that the following parts are supplied. The quantities in the parentheses apply for the 4P type.

TABLE 5.4

The quantities in the parentheses apply for the 4P type.

PART No.	QTY.	DESCRIPTION	NOTE
420-6124-06	1	OWNERS MANUAL DAYTONA USA SP ENG	DAYTONA USA SPECIAL OWNER'S MANUAL
220-5381	4 (2)	KEY MASTER FOR 220-5380	For opening/closing the doors
	16 (8)	KEY	For the CASHBOX DOOR
220-5347	2 (2)	KEY FOR DS - 770 2P No. 302	Refer to Section 11.
540-0009-01	1 (1)	WRENCH FOR TAMP PRF SCR DUAL TYPE M8	Tool
540-0007-01	1 (1)	WRENCH FOR TAMP PRF SCR DUAL TYPE M5	Tool
220-5373	8 (4)	VOL CON B-5K OHM	For spare, refer to Section 13, 15.
220-5484		VOL CON B-5K OHM	
200-5297	8 (4)	REMOTE CONTROLLER H	For adjustment, refer to Section 20.
200-5298		REMOTE CONTROLLER M	
509-5566	8 (4)	SW MICRO TYPE (OMRON SS-5GLT)	For spare, refer to Section 14.
514-5036-7000	4 (2)	FUSE 6.4 $\phi$ $\times$ 30 7000mA 125V	For spare, refer to Section 17, 22.
514-5036-15000	1 (1)	FUSE 6.4 $\phi$ $\times$ 30 15000mA 125V	

### TOOL

(TAMPERPROOF WRENCH) →

M5 540-0007-01

M8 540-0009-01

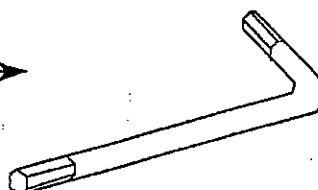

## 6. METHOD OF INSTALLATION AND ASSEMBLY

### 6-1 PREPARATIONS PRIOR TO INSTALLATION AND ASSEMBLY

This is a large-sized complex machine. If the method of assembling is incorrect, the machine cannot be assembled accurately and may be subject to damage or this may cause danger to the workers. Prior to installation and assembly, the following should be prepared and checked.

- (1) Determine the installation positions of the power supply and the compressor by paying attention to the machine's dimensions, the expected space layout of the installation location as well as the position of the Attendant at the time of operation. For the requirements of the compressor's installation location, refer to the following Section. In the countries where the machines are exported to, prepare the compressor required by that particular country's laws and regulations. Specifications for the compressor are as follows:
  - Pressure : 7 to 8.5 kgf/cm<sup>2</sup>
  - Discharge air : 300 ~ 350 liters per min.
  - Applicable gas : Air
  - Diameter of Connection Air Tube : 10 mm
  - w/air dryer (used for removing water content)
- (2) The power supply cable wiring work should be performed by technical staff officially qualified for electric work. When installing the machine in foreign countries, make sure that the wiring work is performed by technical staff qualified for the work, equivalent to said personnel, or be sure to comply with the legal requirements applied to the installation location.
- (3) As regards the indoor wiring for the power supply, be sure to meet the requirements of AC 3-phase 200V 80A or higher (50A or higher for the 4P type). The same amperage requirements apply to the AC 220V to 240V AREA, also.
- (4) Prepare the power cable for connecting the indoor power supply and breaker box. For the 4P type, use AWG No. 4 (in excess of rated amperage of 60A), and for the 8P type, AWG No. 2 (in excess of rated amperage of 80A).
- (5) In accordance with the instructions herein stated, make power supply connections and turn the power on. For the precautions to be heeded at the time of turning the power on, refer to Section 7.
- (6) From the point of view of safety, the assembly work should be performed by 3 persons (at the minimum). Eight persons are required to install the Banner.
- (7) Prepare a discharge water container. This machine discharges drain water (a maximum of 1.5 liters in the 4P type and a maximum of 3 liters in the 8P type on a daily basis).
- (8) Prepare the following equipment and tools:
  - Socket wrench for the hexagon bolts and nuts of M8 & M5 sizes.
  - Wrench (w/ a 24 mm width across flats)
  - Plus Driver
  - Measure
  - Master key (Accessory)
  - Ladder and step

To assemble the option Banner, prepare an M6 size socket wrench, also.

After preparing the above, proceed with assembling in the sequential order as explained below:

## 6-2 COMPRESSOR

**CAUTION!** When using this machine outside Japan, the usage of the compressor of the manufacturer designated by SEGA may not be allowed in some countries. In such cases, choose the compressor designated by the laws applied to the area where the installation location is, and install it in compliance with the instruction manual of the compressor.

Considering the expected layout of the machine's installation locations as well as the method of operation, first determine the installation position of the compressor. Provided, however, that the installation place of the compressor should meet the following requirements:

Herein, explanations regarding the compressor of the manufacturer designated by SEGA are given.

- (1) Indoors where air circulation is good and indoors where the humidity is limited.  
Temperature: 0 to 40 degrees C  
Humidity: 0 to 80%  
Altitude: Less than 1,000 m
- (2) A place with firm floor surfaces such as concrete which allows the compressor to be installed in level position.
- (3) A place with a ventilator, etc. which allows sufficient ventilation to be obtained.
- (4) The atmosphere should be free from dust, and corrosive/explosive gases.
- (5) A place with sufficient space which allows maintenance inspections to be easily carried out (refer to Fig. 6.2 a).
- (6) A place where persons except for those who are concerned are not allowed to enter.

This machine drives the ACTUATOR (AIR CYLINDER) by means of air compressed by the compressor. When the machine is in operation, the compressor is always in activated status. When the compressor is in operation, noise and vibration occur. Therefore, be sure to install the compressor at a place away from the machine so as not to disturb the location operation or game play.

- Provide adequate space between the compressor and the wall surfaces, in excess of 1 meter for the front of the compressor, more than 50 cm. at the left-hand side (air intake side) and more than 30 cm. for other applicable directions.
- The compressor automatically discharges the water (which accumulates in the tank). Connect the nylon tube (attached to the compressor) to a dewatering container.
- A 20 liter polyethylene container is expected to hold drain water that may be accumulated over a period of a week.
- The compressor exhausts air in an upward direction. Make sure that around the exhaust outlet (designated by SEGA) there is no items interrupting the exhaust outlet.
- In the case where the installation location has a low ceiling and the ventilation is expected to be insufficient, change the upward exhaust to a horizontal exhaust. In this case, reposition the lid from horizontal to upward exhaust.

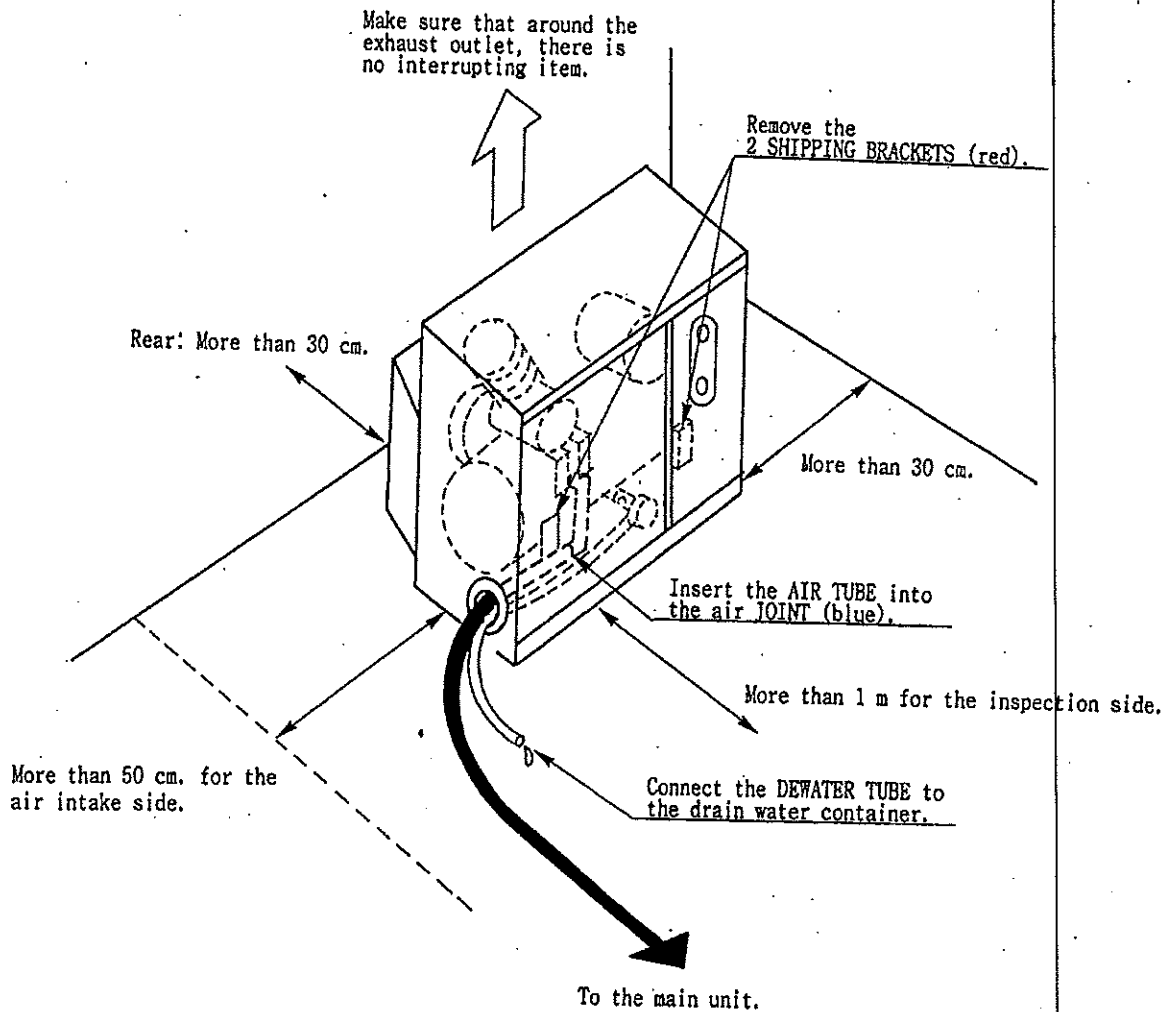

Fig. 6.2a COMPRESSOR INSTALLATION

- ① Open the door and remove the 2 shipping brackets (red) which secure the compressor's leg portions.
- ② Connect the 20 m AIR TUBE to the compressor's air joint.
- ③ Connect the other end of the 20 m Air Tube to the Air Connector of the Side Lid.

## CONNECTION BETWEEN THE COMPRESSOR AND THE MACHINERY

For the connection between the COMPRESSOR and the machinery, follow the procedure below:

- ① Depending on the countries, the standards on Compressors are different. Provide the Compressor which satisfy the country's legal requirements applied to the locality. Specifications for the Compressor are as stated above.
- ② Secure the Regulator (an accessory) to the Compressor.
- ③ Connect the Air Joint (an accessory) to the Compressor.  
There are 3 types of Air Joints. Utilize the one which can meet the diameter of the Compressor's air exhaust port.
- ④ The Air Tube (20 m) which comes from the machinery is to be connected with the Regulator. Utilize part of this tube by cutting it off for the Air Tube used between the Air Joint and the Regulator. When connecting, pay careful attention to the IN and OUT sides of the Regulator.
- ⑤ Set the Regulator's Pressure Gauge to  $5 \text{ kgf/cm}^2$ . When the Compressor is activated, the indication of the Regulator's Pressure Gauge starts to increase. Set the set pressure to  $5 \text{ kgf/cm}^2$  by turning the Regulator's knob.

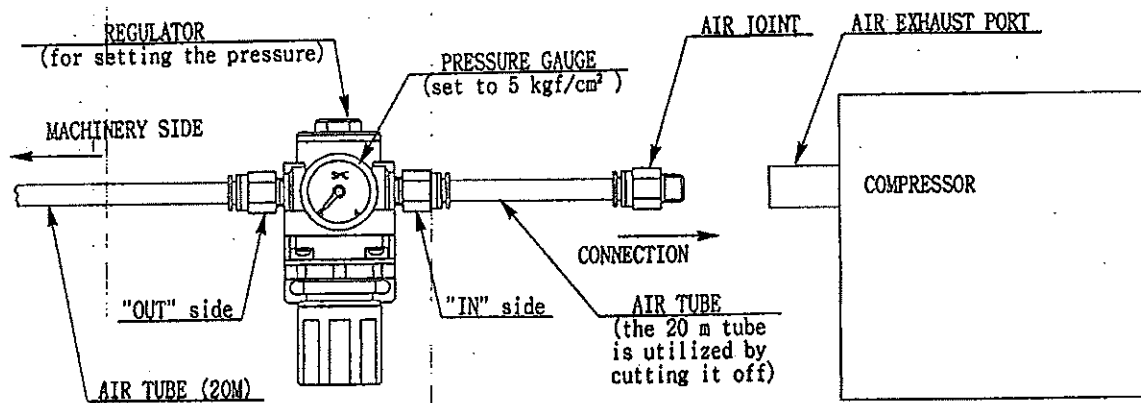

Fig. 6.2b



## 6-3 PTV

When transported, the projectors do not have Seat Nos. By attaching the billboard to the projector, that particular PTV is for the corresponding Seat in the sequential order of Seat No. 1, No. 2 ....

After assembling, line up the PTVs in the sequential order of No. 1, No. 2 ..... starting from the left-hand side (facing the PTVs). Have each Seat's power cord, air piping, and between-each-Seat's communication cable pass through each joint box in front of the PTV. Before installing the front cabi to the PTV, make sure that wirings and pipings are performed to the PTV side.

**CAUTION!** The communication cables are made of optic fiber and susceptible to bending and shocks. When damaged, they can not be repaired. Be very careful when handling them.

- ① Install the Billboard, Mask and Joint Box to the Projector (Fig. 6.3 a ). This should be done by more than one person.
- ② Sequentially line up the PTVs (Fig. 6.3b) at the corresponding applicable positions of the machinery installation. After this procedure, it is very difficult to move the machinery with several PTVs installed.
- ③ Join each PTV by installing 3 Joint Holders with 2 each of Hexagon Bolts in between each PTVs (Fig. 6.3c). Install the Joint Holders to the underneath of the Billboard's projected portion, to the Billboard Ceiling and rear portion.
- ④ Cause all of the Leg Adjusters of all PTVs to come into contact with the surface. Make adjustments so that the casters are raised approximately 5 mm from the surface. After adjustments, tighten Leg Adjuster Nuts upward to fix the height of Leg Adjusters (Fig. 6.3 d).
- ⑤ Install Wire Cover A in between each PTV Joint Box. Apply the notch portion of Wire Cover A to the Bolt projecting to the front of each PTV, put the flat washer on to the Bolt, tighten the Flange Nut, and secure Wire Cover A (Fig. 6.3b).
- ⑥ Install Side Lid to the right-hand side of the PTV Joint Box for Seat No. 8 (No.4 in the case of the 4P type). Secure the Side Lid with 2 Truss Screws (Fig. 6.3b). The Air Connector comes with the Side Lid. Insert the Air Tube, which comes from the Compressor, into the Air Connector.

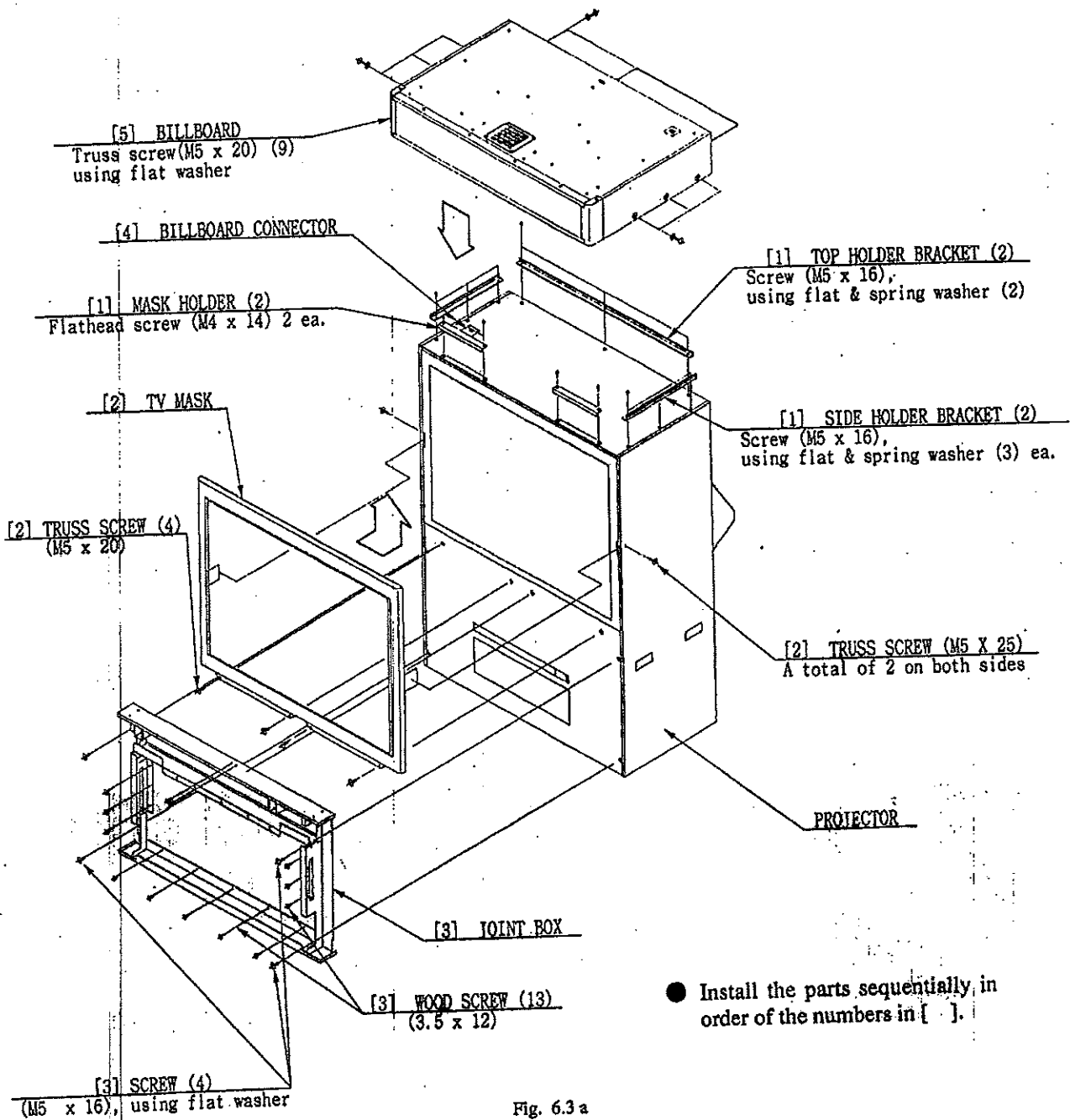

Fig. 6.3 a

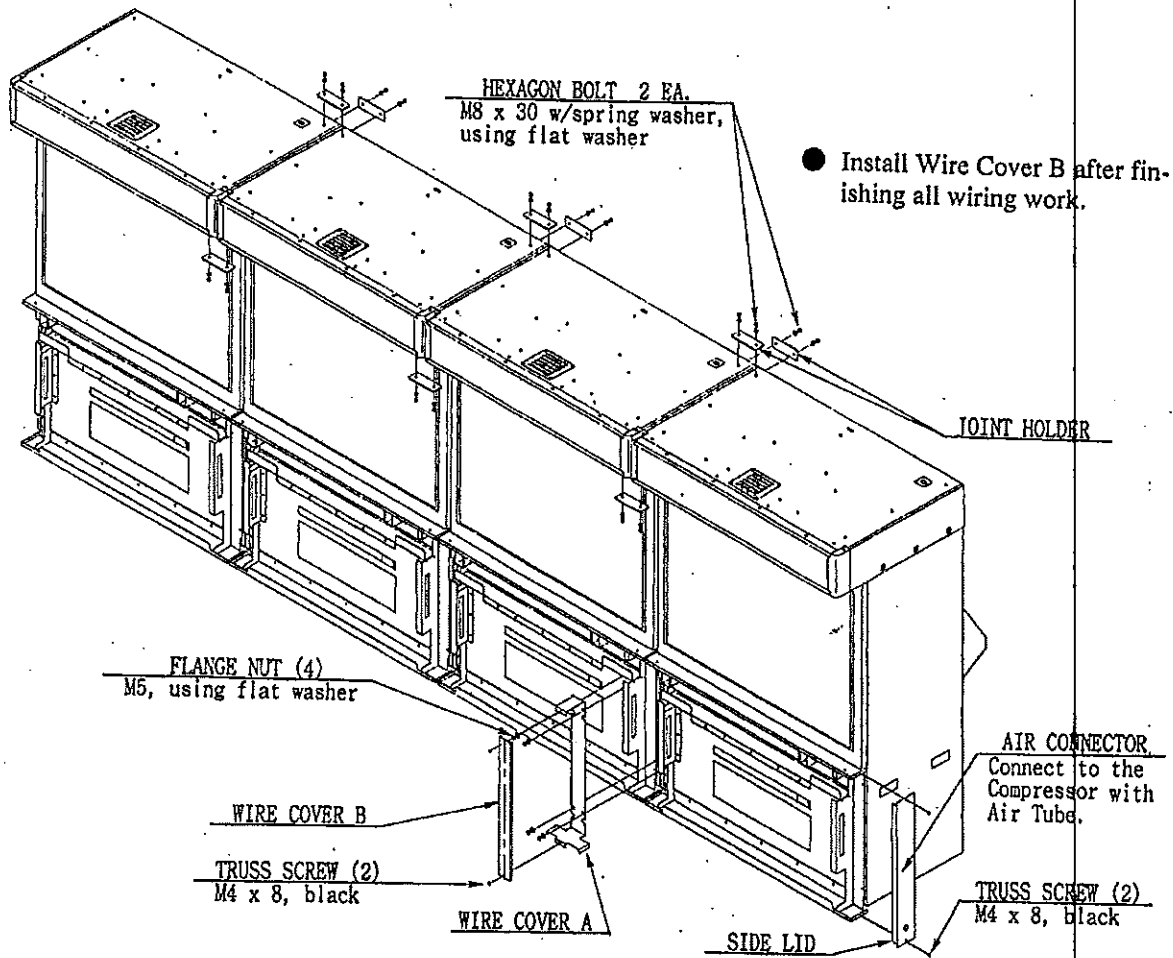
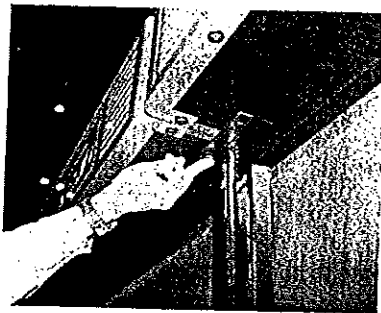
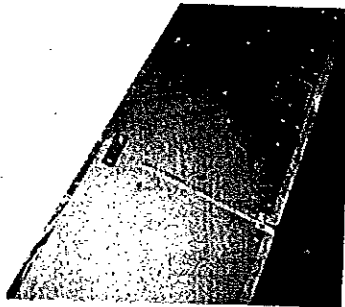

Fig. 6.3b



Underneath the Billboard's  
projected portion



Billboard Ceiling

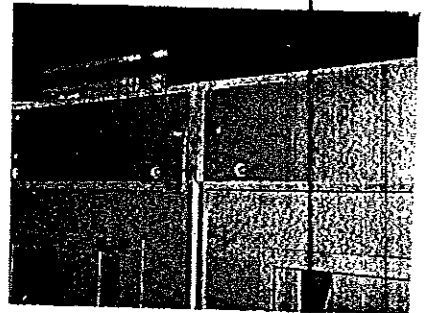

The rear part of the Billboard

Fig. 6.3c

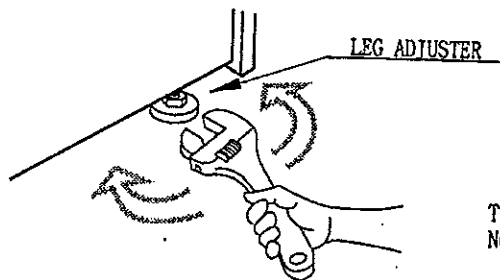
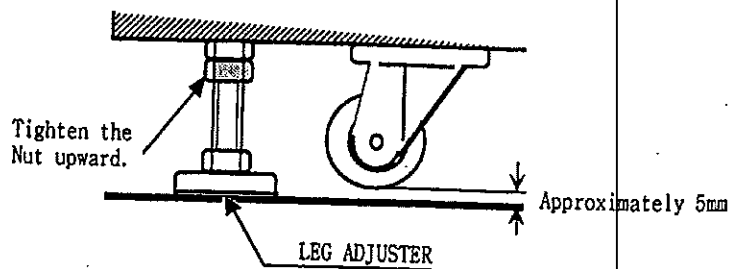

Fig. 6.3d



- ⑦ Perform the wiring work. Connect the wiring between the PTV and Front Cable to the PTV side. The Connector Panel is positioned on the underside of the front of PTV. Connect the Connectors to each terminal of the Connector Panel. Insert the red, green, and blue Connectors into the corresponding RGB terminals as applicable, and the remaining Connector to the remaining terminal (SYNC). For these 4 Connectors the insertion angle is fixed. Forcible insertion may cause damage to the Connectors, so ascertain the correct angle for insertion. After insertion, turn the Connector Ring to the right and lock the connection (Fig. 6.3 e).

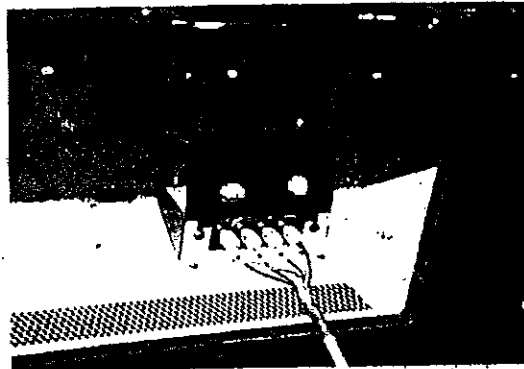

Fig. 6.3 e

- ⑧ After making wiring connections to the Connector Panel's 3P and 4P Connectors, secure the wiring by using the wire fasteners which come with the Joint Box (Fig. 6.3f).

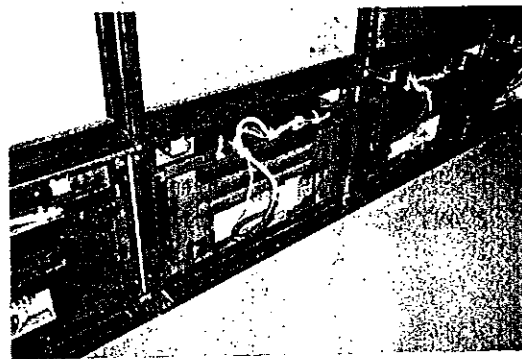

Fig. 6.3 f

In the following procedure ⑨ to ⑫, pass the wiring, which connects each Seat and Control Tower, through a series of Joint Boxes. Since the Control Tower is positioned closer to Seat No. 1, pass the wiring through accordingly in a manner so that the end opposite each Seat's terminal connection side is always positioned towards Seat No. 1 (Fig. 6.3 g).

Note that there are 2 wiring groups, one for No. 1 to No. 4 and the other for No. 5 to No. 8 (in the case of 4P type, only one group for No. 1 to No. 4).

- ⑨ Pass the power cord for each Seat through the Lower Shelf of the Joint Box. Make sure that one socket outlet is available for each PTV (Fig. 6.3 h).

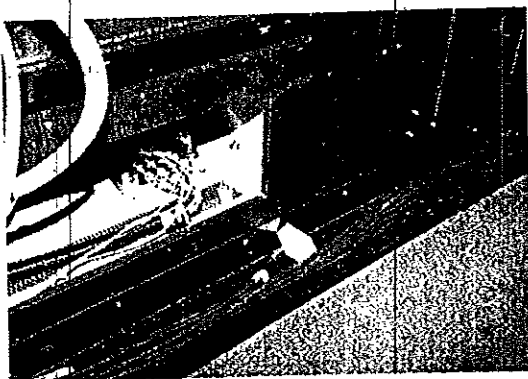

Fig. 6.3 h

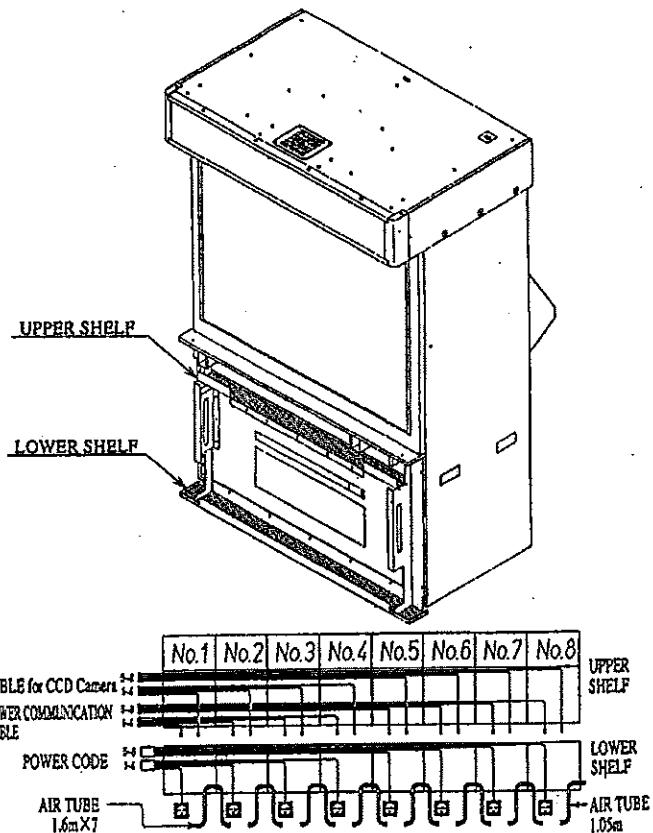

Fig. 6.3 g

- ⑩ Pass the wiring between each Seat and the Control Tower through the Upper Shelf of the Joint Box.
- ⑪ Pass the wiring for the CCD Camera through the Upper Shelf of the Joint Box.
- ⑫ Pass the Air Tube through the Lower Shelf of the Joint Box. Provide an Air Tube in between each Seat, and an Air Connector in the Joint Box of Seat No. 8 (No. 4 in the case of the 4P type), and an Air Tube for Air Joint for Seat No. 8 (No. 4 for the 4P type) (Fig. 6.3 g).
- ⑬ Pass the Communication Cable between each Seat through the Upper Shelf of the Joint Box. Depending on the number of Seats to be connected, where the Communication Cable is to be connected to is different. Pay careful attention to the RX and TX display indicated at the end of the Communication Cable and make sure that the Communication cables are laid out as shown below (Fig. 6.3 i).

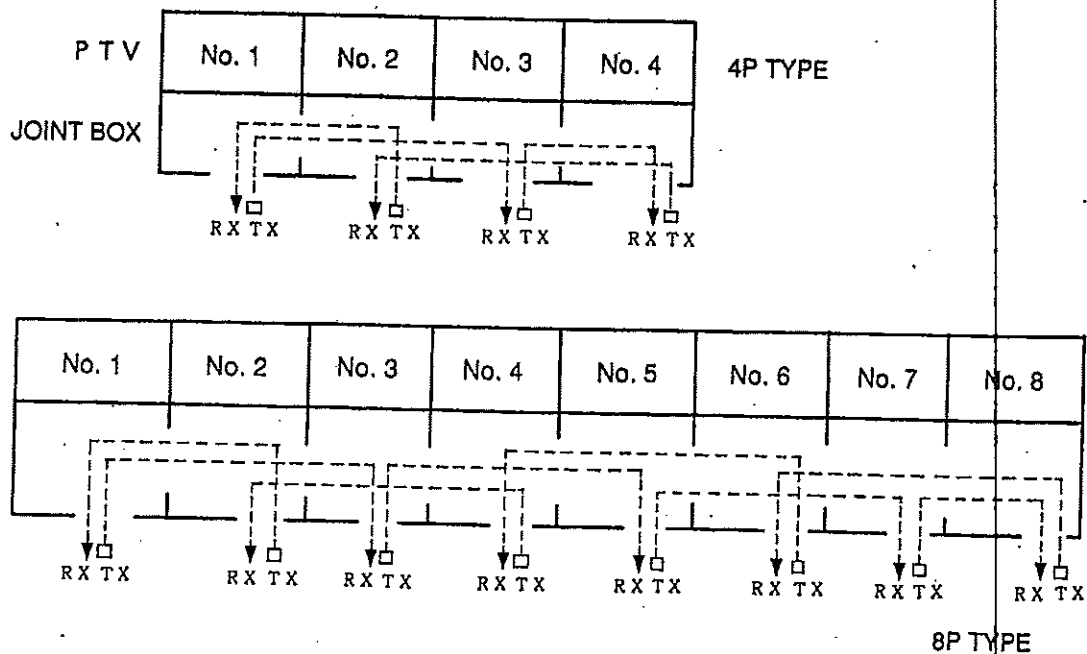
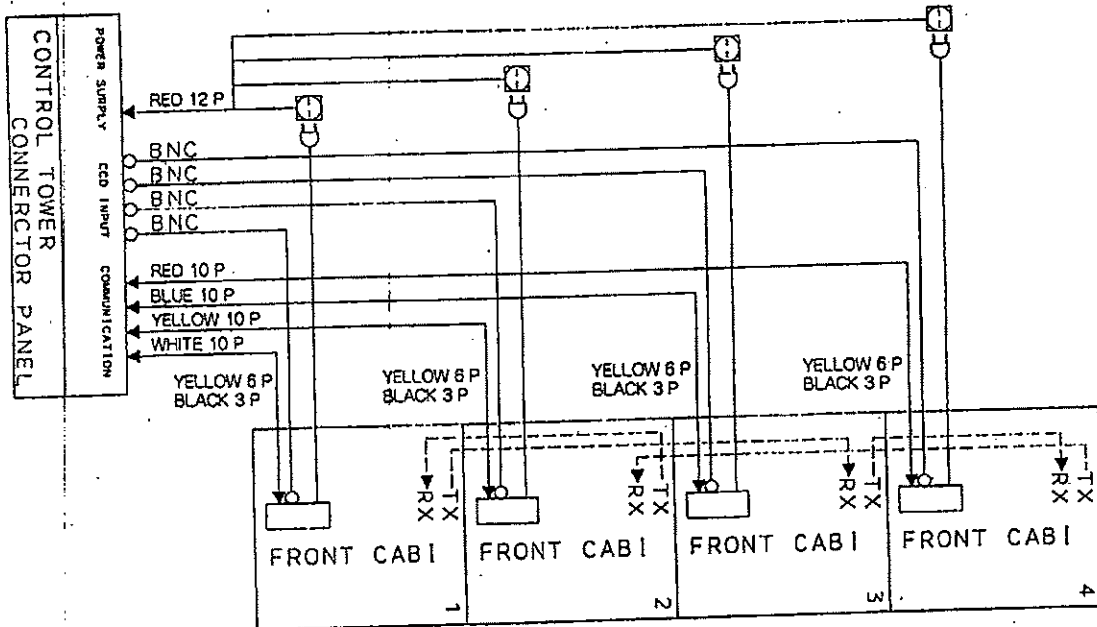

Fig. 6.3 i

By following the above procedure, the wiring and piping work inside the Joint Box can be finished. The paragraph below explains the procedure in which the Front Cabl is joined with the PTV and the joining results are shown in Fig. 6.3 j.

- ⑭ Install Wire Cover B to Wire Cover A with 2 screws (Fig. 6.3 b).

☐ FOR THE 4P TYPE



☐ FOR THE 8P TYPE

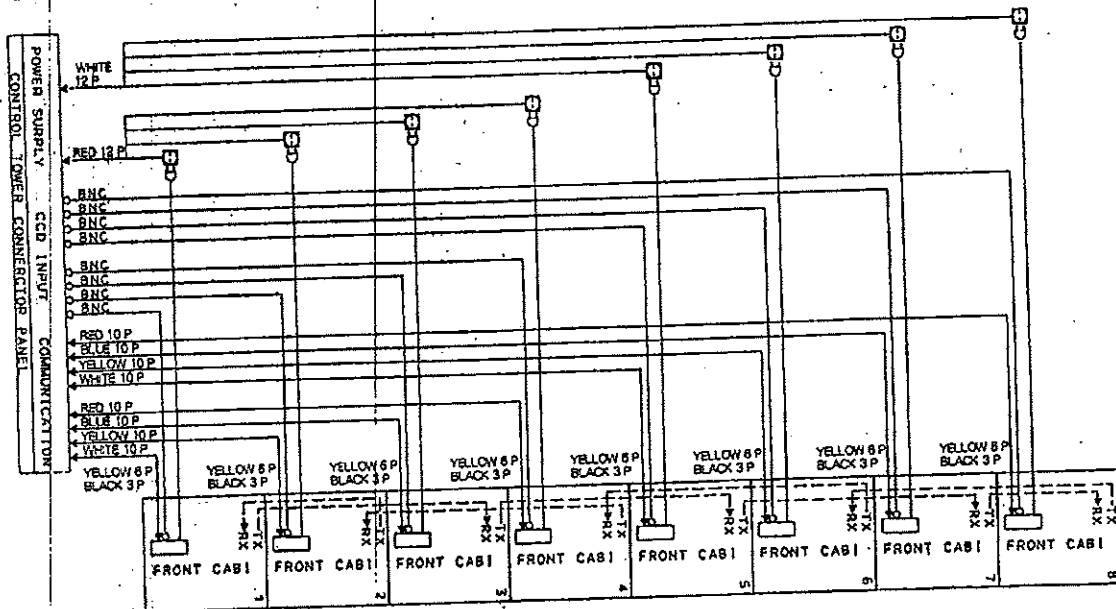

Fig. 6.3j

## 6-4 FRONT CABI

Install the Front Cabi to the PTV. The Front Cabi has its Seat No., so when installing, make sure that the No. corresponds to that of the PTV. Although the electric wiring for each Seat is independent, make connections of the Air Tube and Communication Cable between each Seat. Proceed with the work sequentially in order of Seat No. 1, No. 2, No. 3 ...

- ① Apply the Stickers to the one side of PTV and Front Cabi of Seat Nos. 1 and 8. (No. 4 PTV and Front Cabi in the case of the 4P type) (Fig. 6.4 a).  
Apply the Stickers on the outer sides of the Front Cabinets when Seat No. 1 to No. 8 are lined up.

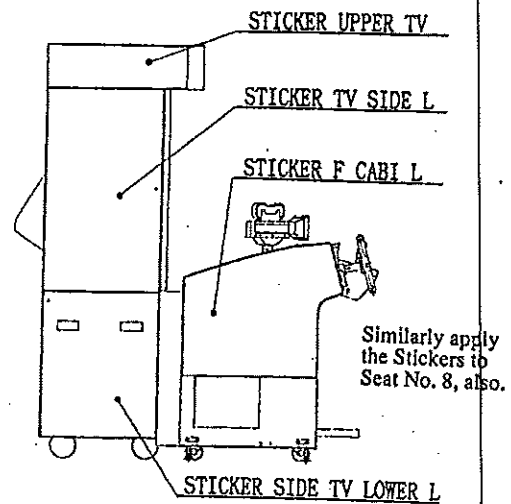

Fig. 6.4 a APPLICATION OF STICKERS

- ② Take off the Service Door of the Front Cabi. Take off the 2 screws and unlock by using the master key. The wiring for the Fan is connected to the Service Door. Disconnect the Connector to remove the Service Door (Fig. 6.4 b).

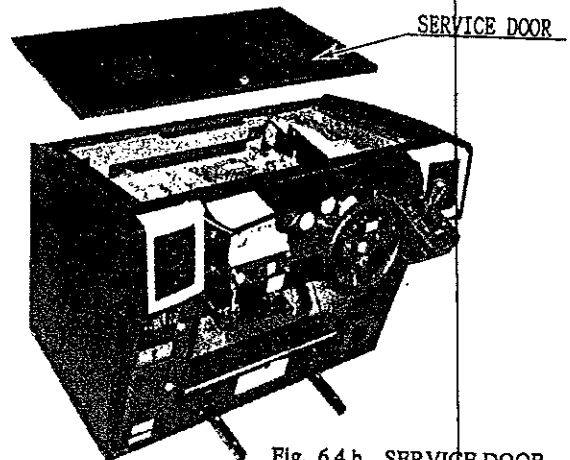

Fig. 6.4 b SERVICE DOOR

- ③ On the surfaces where the Front Cabi and the PTV are jointed, one each Joint Bracket is attached to the right and left sides.

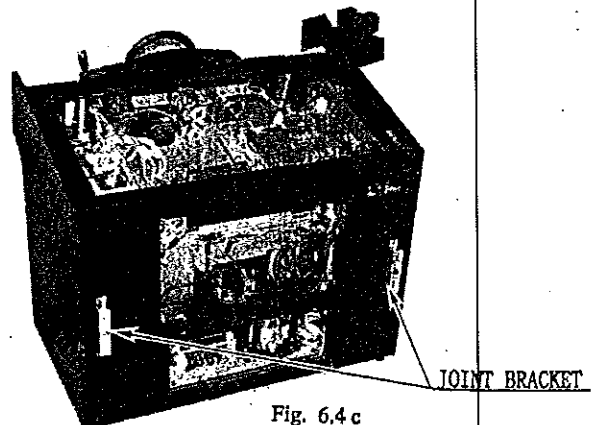

Fig. 6.4 c

- ④ Insert the Front Cabi's power cord plug into the Service Outlet provided for the PTV and Joint Box.
- ⑤ Joint the Front Cabi and the PTV by hanging the Joint Bracket on the Slit of the Joint Box in front of the PTV (Fig. 6.4 d).

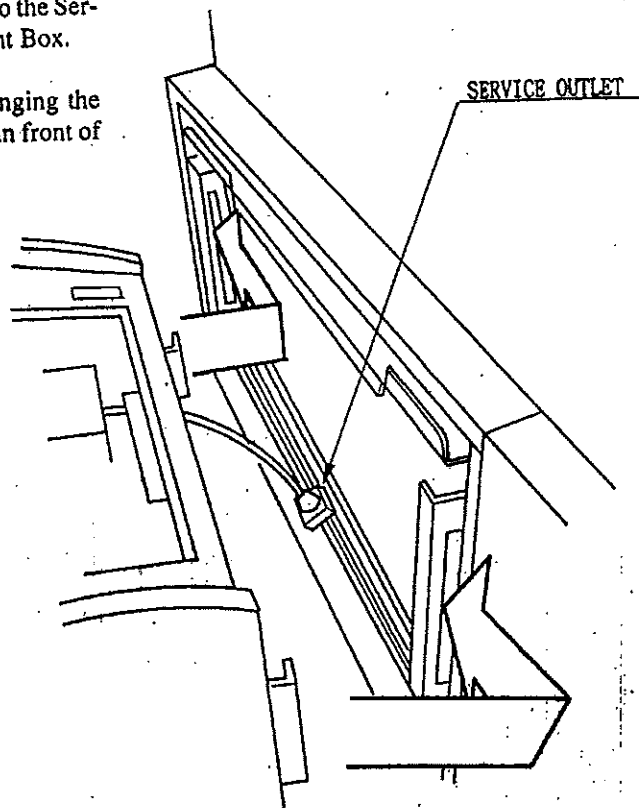

Fig. 6.4 d

- ⑥ Inside the SERVICE DOOR, there are one each of Punch Lock on the right and left sides. By utilizing the Punch Locks, joint the PTV and Front Cabi. (Fig. 6.4 e).

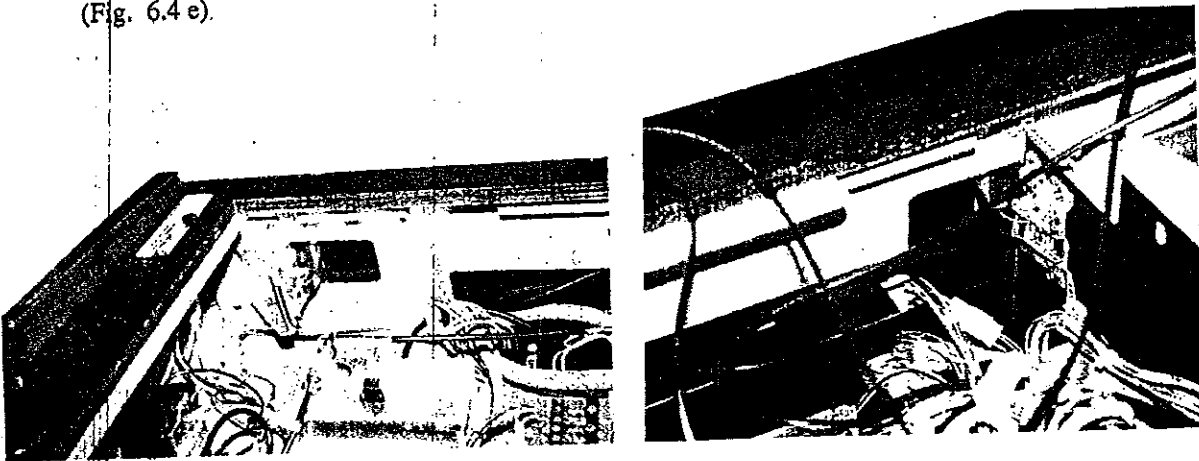

Fig. 6.4 e



⑦ Inside the SERVICE DOOR, starting from the left facing the PTV, there are Connector Bracket, VPM Buffer Board, Air Joint and Shield Case (Fig. 6.4 f). Insert the Connector and Air Tube of the wiring and Communication Cable for each of them (Fig. 6.4 g).

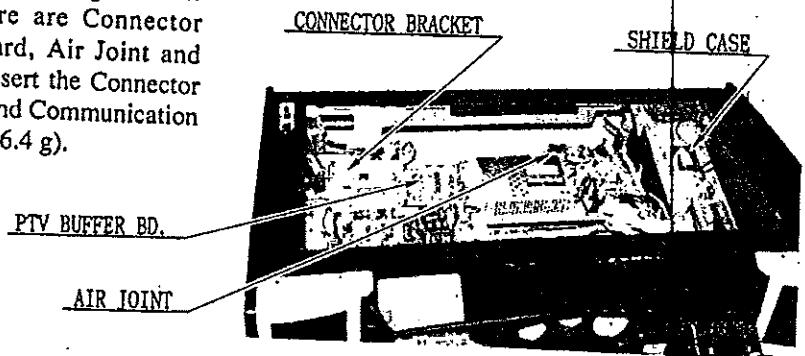

Fig. 6.4 f

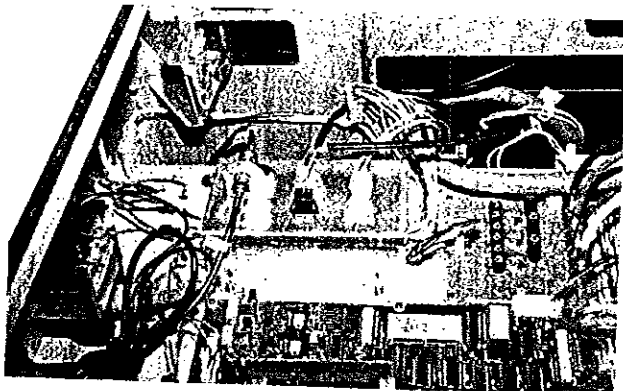
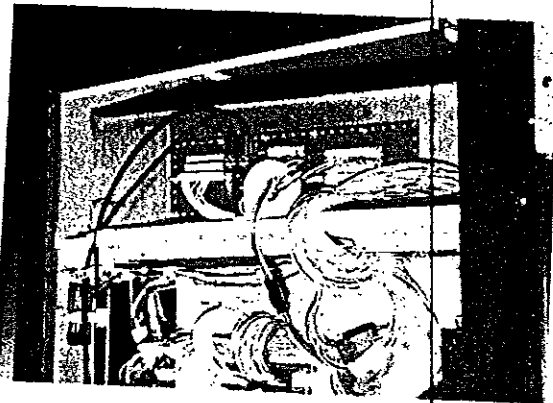

Fig. 6.4 g CONNECTOR BRACKET AND VPM BUFFER BD.



SHIELD CASE

To each of the R. G. B. and SYNC terminals, insert the corresponding applicable wiring connectors (with red, green, or blue wire color and the remaining color). The Connector insertion angle is fixed. Ascertain the angle to insert the Connector, and turn the Connector Ring to the left to lock the connection.

The same applies to the BNC Connector for the Connector Bracket's wiring for the CCD Camera.

Insert the Communication Cable to the Shield Case Connector in the manner corresponding to RX and TX positions displayed, as applicable.

Insert the Air Tubes to the Air Joints in a manner so as to be connected with adjacent Seats. Insert Air Joint 10 Plug into the Air Joint of Seat No. 1 (to the side closer to Control Tower).

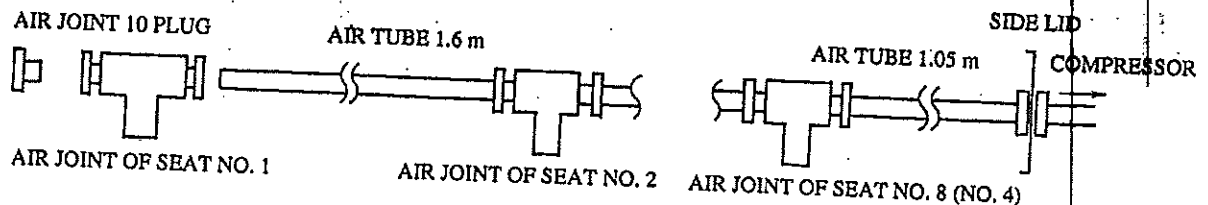
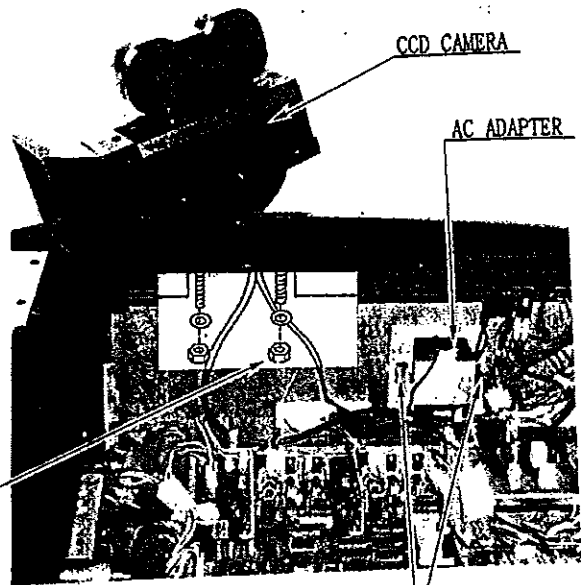

Fig. 6.4 h

Also, make connection of 1P green Connector to connect the PTV and Earth Wire.

- ⑧ Install the CCD Camera. Pass the CCD Camera's wiring through the slits and mount the CCD Camera on the Front Cabi. Attach Nuts to the Bolts of the Camera Support Board and secure the Camera. Secure the AC Adapter by fastening the holder with 2 screws.

Insert the power plug into the AC Adapter and connect the Camera Signal wiring Connector to the Connector Panel. The connector insertion angle is fixed. Check the angle before connector insertion. Turn the Connector Ring to the right to lock the connection.



- ⑨ Install the Service Door. First, insert the Fan's wiring Connector to the Connector Panel, and close the door. When closing the door, be very careful so as not to catch the wiring, etc.

Fig. 6.4i

- ⑩ Loosen the 2 screws from the CCD Camera Support and turn the Camera fully in the direction where the player is to be seated. Retighten the 2 loosened screws and securely fasten the Camera in the correct direction.

- ⑪ Have the Leg Adjusters contact with the surface. When the Front Cabi and the PTV are joined, the clearance between Front Cabinets is limited so it will be difficult to bring all of the Adjusters into contact with the surface. Try to have as many Adjusters as possible come into contact with the floor.

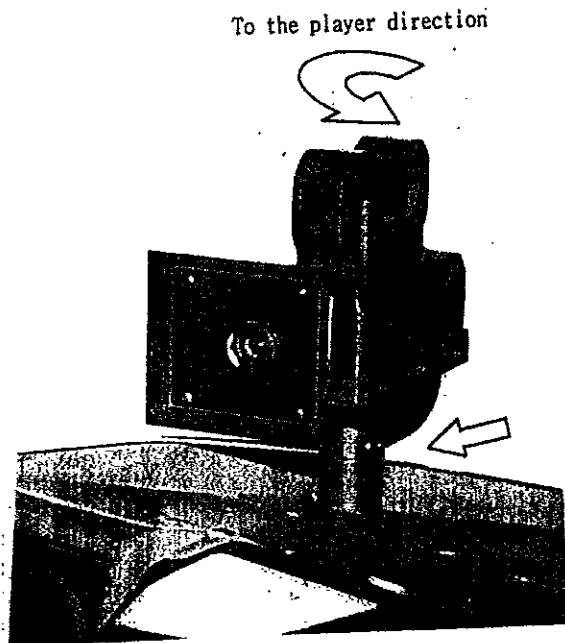

Fig. 6.4j

## 6-5 REAR CABI

After all of the Front Cabinets are jointed with the PTVs, join the Rear Cabinets to the Front Cabinets. The Rear Cabinets have Seat Nos. When joining, make sure that these numbers correspond to the PTV numbers.

As explained in the preceding paragraph, it is difficult to have all of the Front Cabi Leg Adjusters make contact with the surface. If the Leg Adjusters are not in contact with the floor, the machine will not be sufficiently secured and it may move suddenly, which may be dangerous. Since there is sufficient space in between Rear Cabinets, bring all of the Rear Cabi Leg Adjusters into contact with the surface.

- ① Remove the Rear Cabi's Base Lid. First, move the Seat fully to the rear. Remove the 2 screws and the 4 flathead screws from both sides (Fig. 6.5 a).

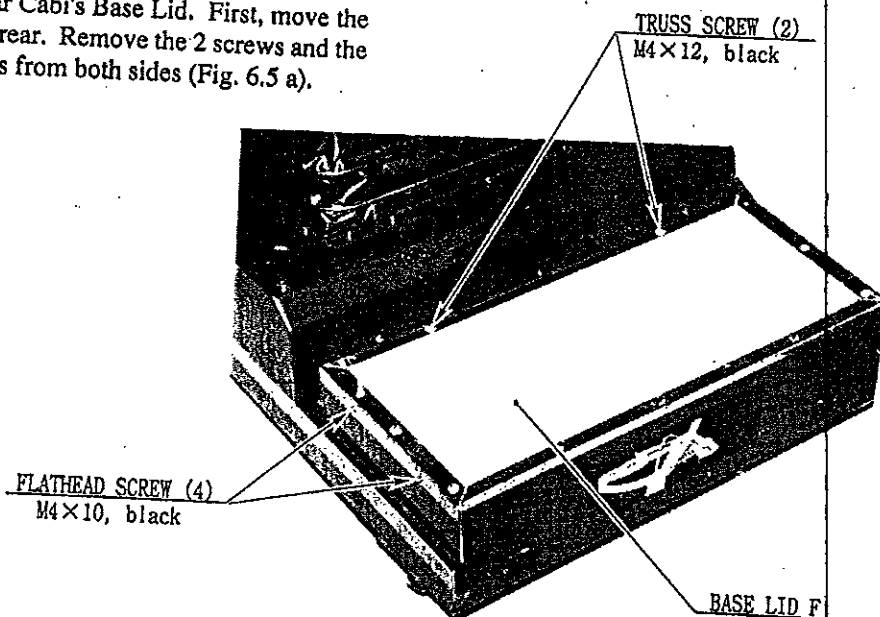

Fig. 6.5 a

- ② As shown, joint the Front Cabi and the Rear Cabi by inserting the Front Cabi Square Pipes into the Rear Cabi (Fig. 6.5b).

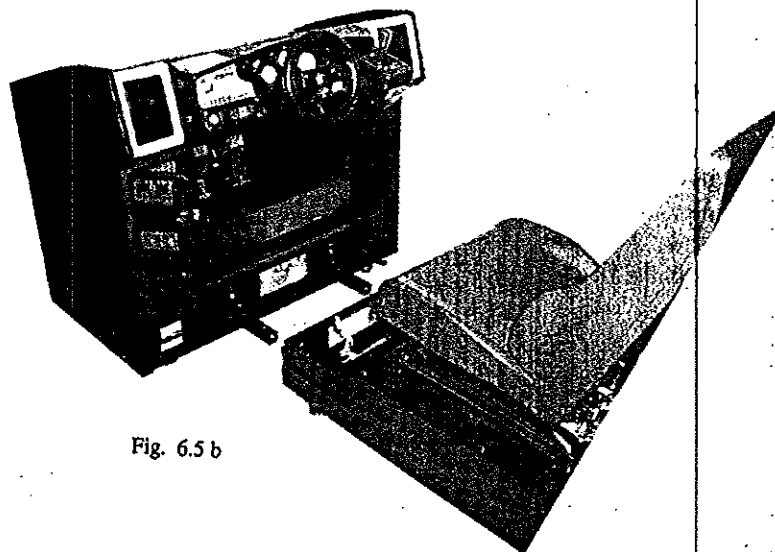

Fig. 6.5 b

- ③ Connect the 2 Wiring Connectors and Air Tube inside the Rear Cabi's Base Lid F. Then, secure the joined Rear Cabi and Front Cabi by using the 2 Hexagon Bolts to the Front Cabi side and the 4 Hexagon Bolts to the square pipes (Fig. 6.5 c).

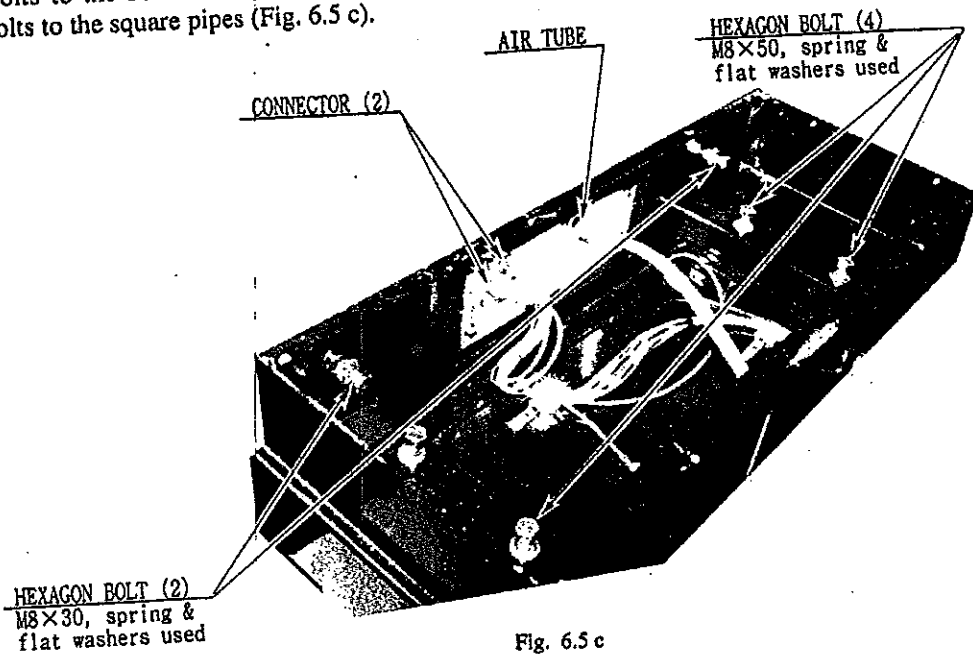

Fig. 6.5 c

- ④ Install Base Lid F to the Rear Cabi and secure with a total of 6 screws which were taken off in Procedure ① above (Fig. 6.5d).

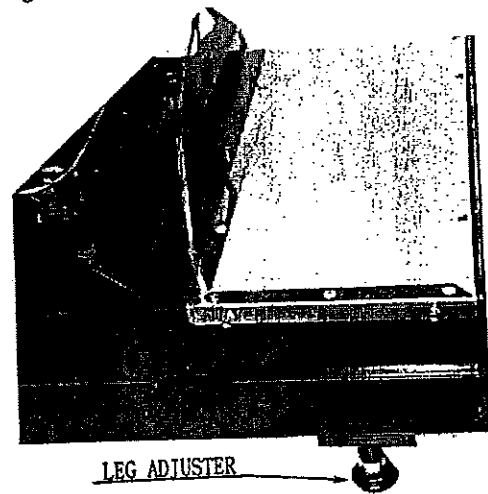

Fig. 6.5 d

- ⑤ Cause all of the Leg Adjusters to come into contact with the surface. Adjust Leg Adjusters so that there is approximately 5 mm clearance between the casters and the surface. After the adjustments are made, fasten the Nuts upwards to fix the height of Leg Adjusters (Fig. 6.5e).

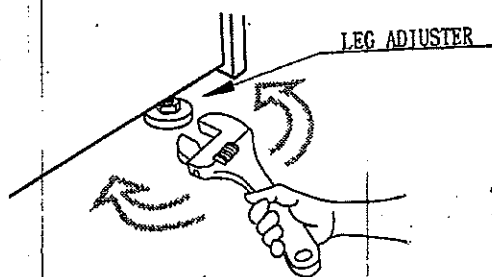
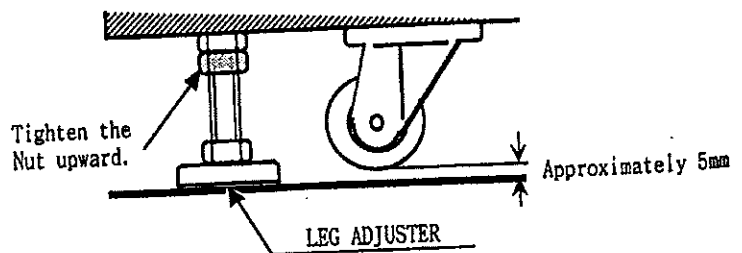

Fig. 6.5 e



## 6-6 MONITORS AND SPEAKERS

On to the PTV, install the 25 inch monitor on which visual images taken by the CCD camera are shown and the speaker that outputs the control tower's microphone input.

Install four 25 inch monitors for the 8P type and two for the 4P type. Install two speakers for both 4P and 8P, one each speaker at both ends of the PTV's lined up.

Depending on the height of the installation location's ceiling, if they can not be installed on top of the PTV, prepare a stand(s), etc., to put them on in a manner meeting the wiring length. Herein, explanations as regards standard installation are given.

- ① Arrange wirings between the control tower and the monitor & speaker on top of the PTV. As in wirings inside the PTV's joint box, wiring connections on the side opposite to the monitor and speaker are all made to the control tower, so be sure to arrange them in the direction of the PTV of Seat No. 1 (Fig. 6.6 a).  
Note that if the option banner and spotlights are to be installed, arrange the wirings for these also at the same time.
- ② Arrange the 25 inch monitors as shown in Fig. 6.6a. For the 4P type, place them in between Seat Nos. 1 & 2, and Seat Nos. 3 & 4.

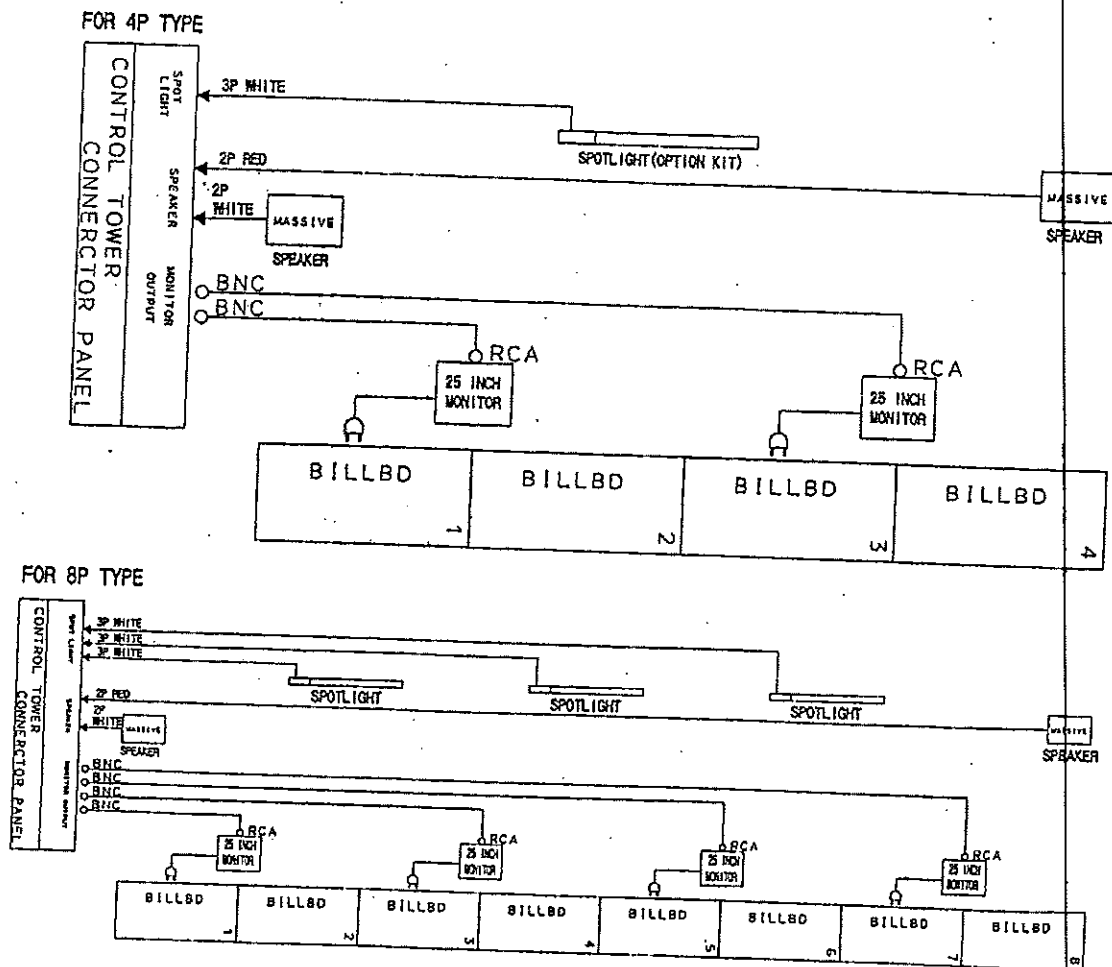
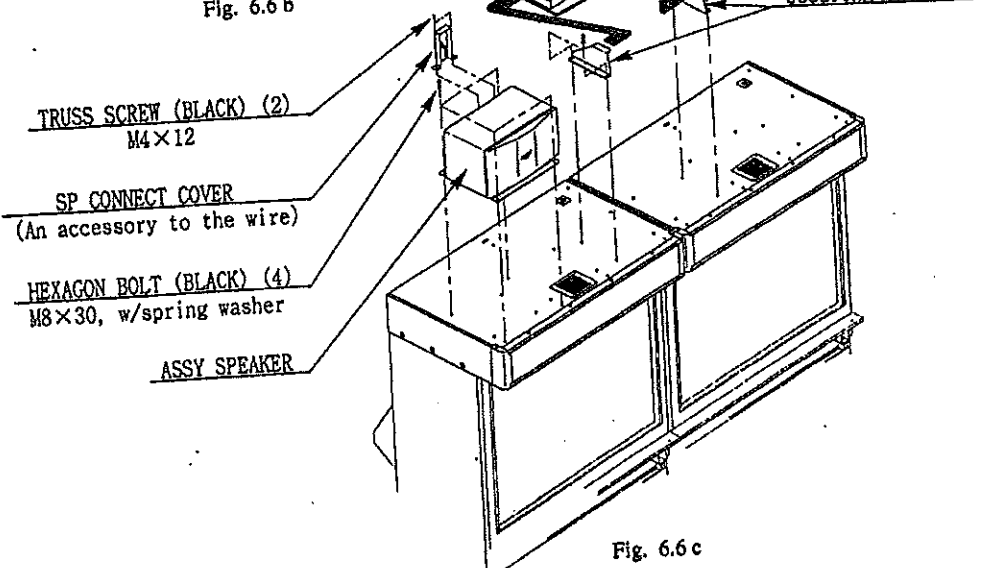
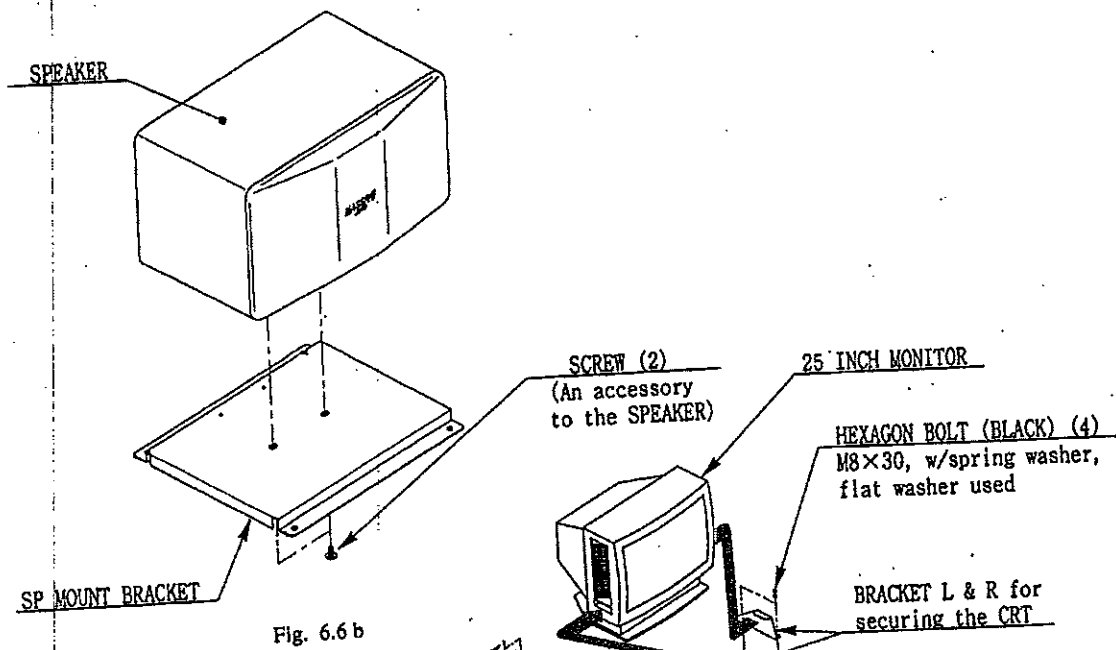

Fig. 6.6 a

- ③ Assemble the speaker and Mount Bracket. Use the two screws which come with the Speaker to assemble the Mount Bracket (Fig. 6.6 b).
- ④ The 25 inch monitor is secured by holding the right and left catch portions with Brackets. Install the right and left Brackets with 2 screws for each (Fig. 6.6 c).
- ⑤ Install the SP Mount Bracket to the PTV ceiling with 4 hexagon bolts to secure the speaker (Fig. 6.6 c).
- ⑥ Make wiring connections to the rear part of the speaker. After making connections, secure the SP Connect Cover to the rear part of the speaker with 2 truss screws (Fig. 6.6 c). The SP Connect Cover comes with the speaker wire.



- ⑦ Make wiring connections to the rear part of the 25 inch monitor. Insert the monitor's power plug into the socket outlet for the PTV ceiling (Fig. 6.6 d).

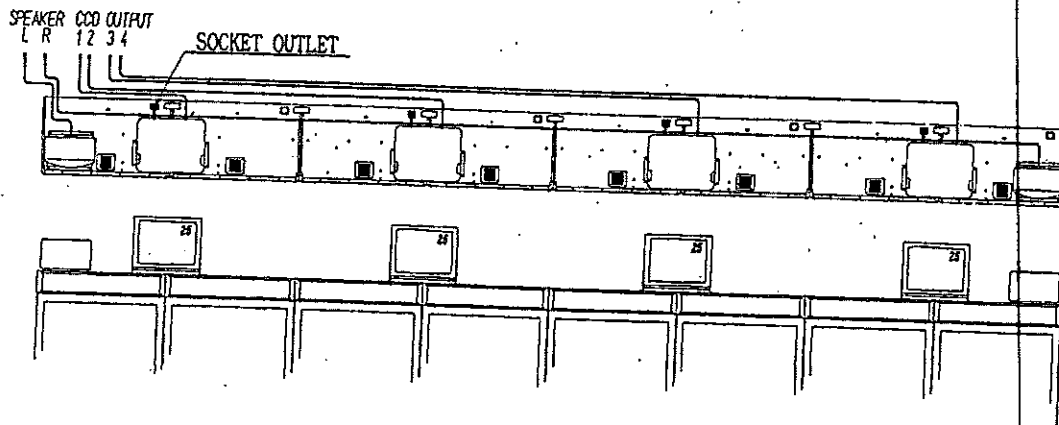

Fig. 6.6 d

## 6-7 BANNER

In this Section, the installation of the option Banner and Spotlights are explained. The Spotlights are for illuminating the Banner. The height of the Banner is adjustable in 4 steps so as to meet the height requirements of the installation location's ceiling. When assembling the banner, start with assembling the framework's pipes and brackets.

- ① Secure joint pipes on the top and bottom of the Frame Bracket. Prepare 4 of these (Fig. 6.7 a). For the 4 P type, prepare 2 of these.

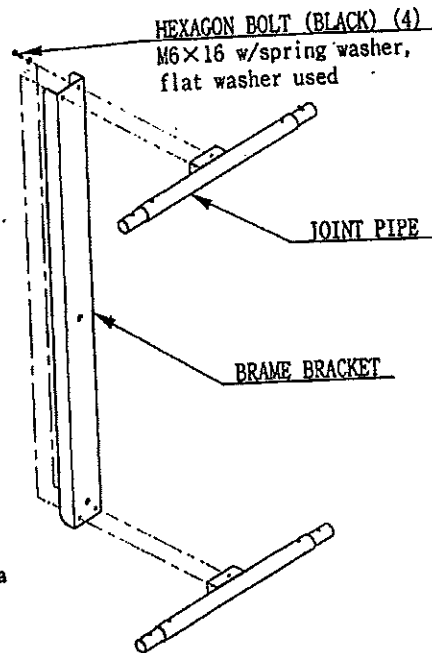
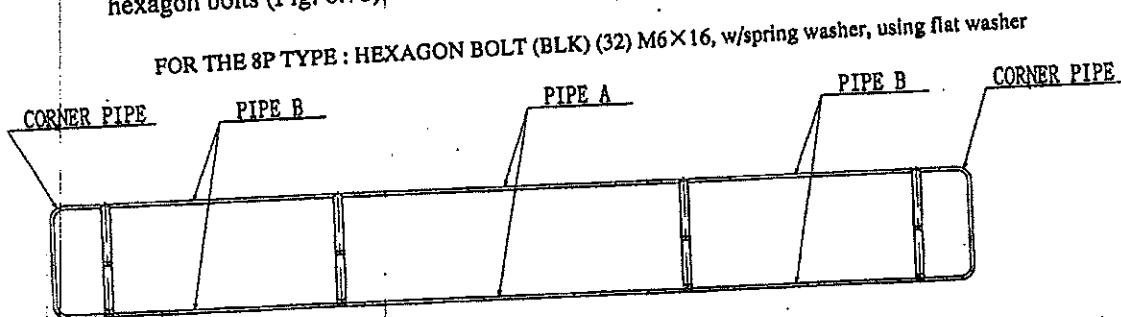

Fig. 6.7 a

- ② Install each pipe (Corner Pipe, Pipe A and Pipe B) to the Joint Brackets and secure them with hexagon bolts (Fig. 6.7b)



FOR THE 4P TYPE : HEXAGON BOLT (BLK) (16) M6x16, w/spring washer, using flat washer

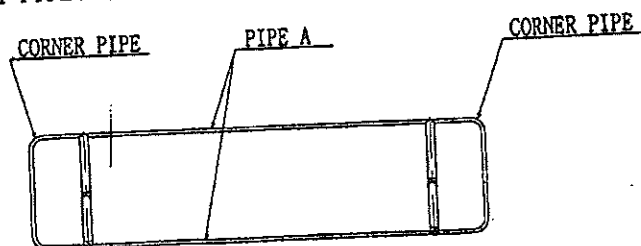
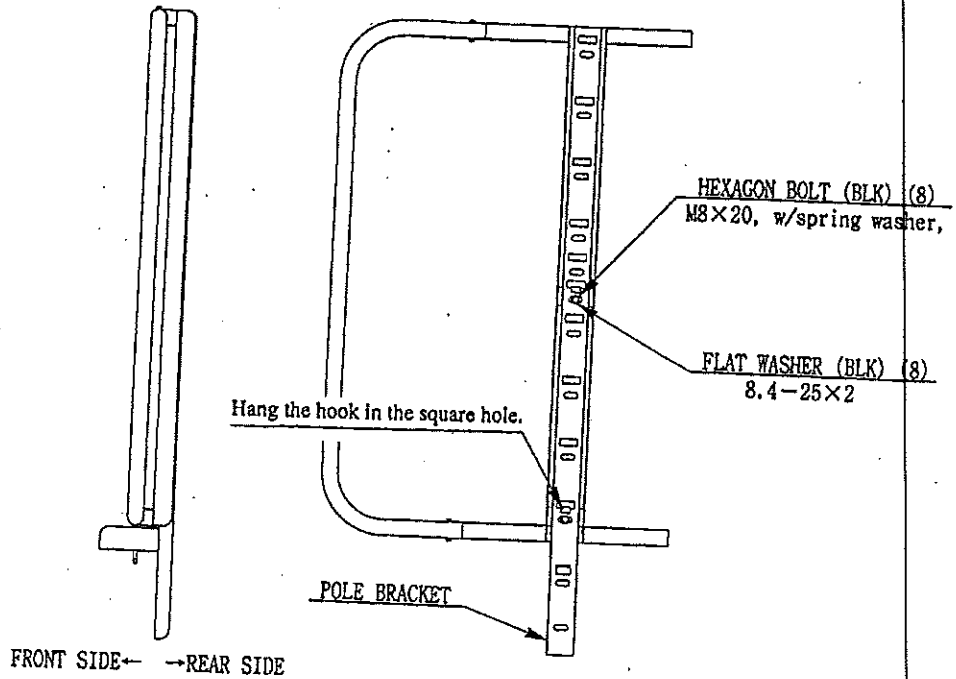

Fig. 6.7b



- ③ Install the Pole Bracket to each Frame Bracket. When installed on the PTV, the height of the Banner is 360 cm. to 306.5 cm. Depending on the height of the ceiling, determine the installation position (Fig. 6.7c). The quantities of Bolts and Flat Washers shown in the Figure are for the 8P type. Half the quantities shown apply to the 4P type.



NOTE : Secure all of the Pole Brackets at the same height.

Fig. 6.7 c

- ④ Hook the Spring Hooks in the Banner's Ratchet Holes from the Banner's printed surface and pull them towards the outside of the Banner (Fig. 6.7 d).

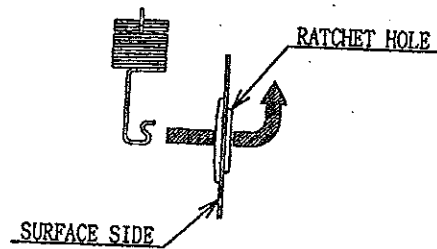

Fig. 6.7 d

- ⑤ Spread the Banner over the pipe and bracket assembly and tie the pipes and spring hooks with holder rings (Fig. 6.7 e).

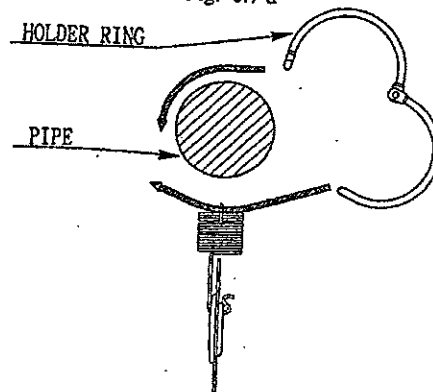
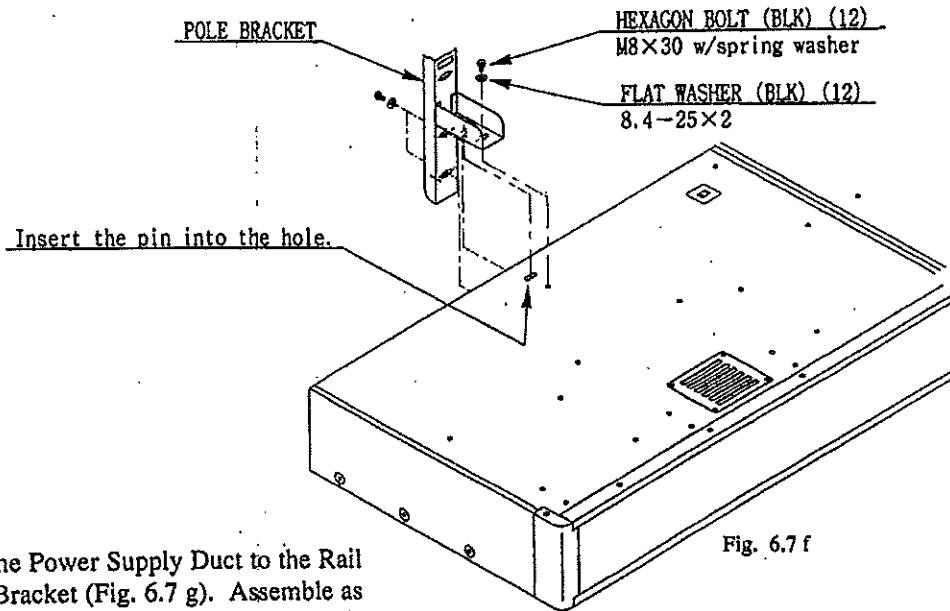
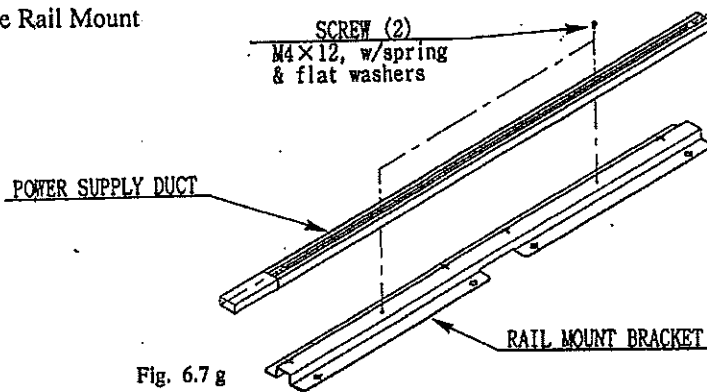

Fig. 6.7 e

- ⑥ Install the assembled Banner to the PTV. Insert the Pole Bracket Pin into the top of the PTV ceiling for positioning. Then, secure the Banner with the hexagon bolt (Fig. 6.7 f). The quantities of Bolts and Flat washers are for the 8P type. Half the quantities apply for the 4P type.



- ⑦ Install the Power Supply Duct to the Rail Mount Bracket (Fig. 6.7 g). Assemble as shown by paying attention to the Duct's wiring connector side and the Rail Mount Bracket's notch position.



- ⑧ Install Spotlights to the Duct (Fig. 6.7 h).

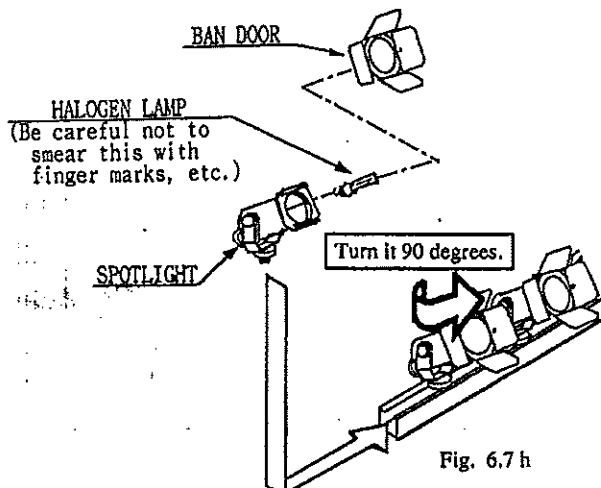

- ⑨ Install the Duct with Spotlights mounted, on top of the PTV (Fig. 6.7 i).

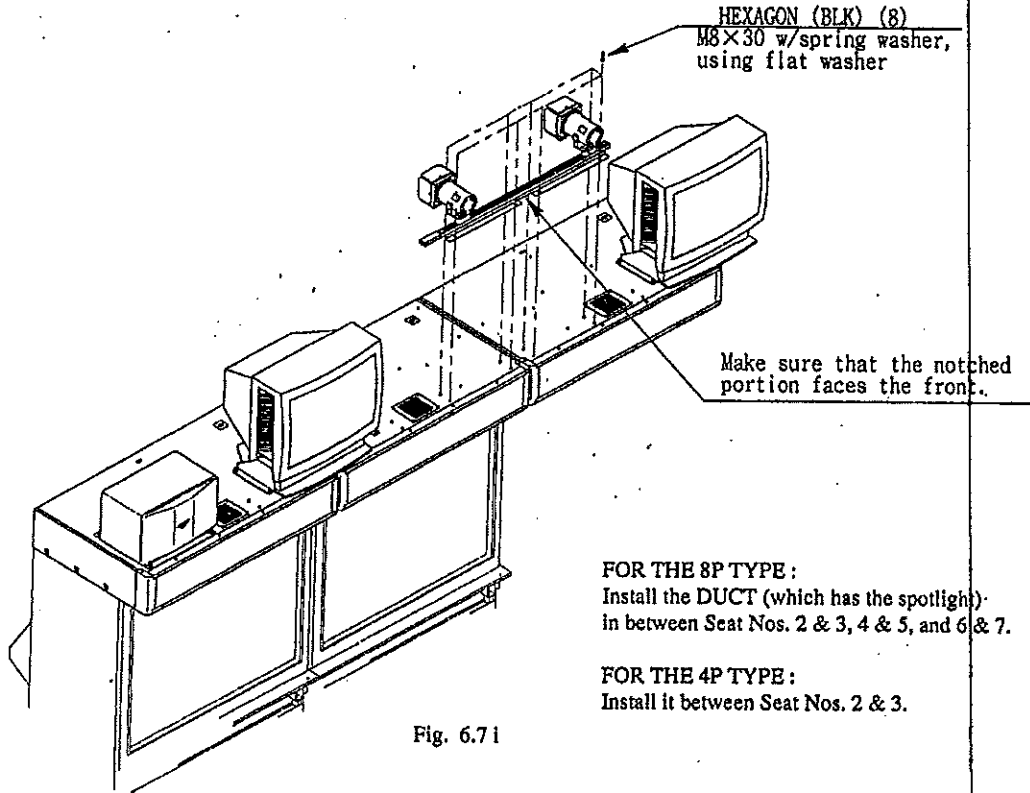

- ⑩ Make wiring connections for the Duct (Fig. 6.7 j).

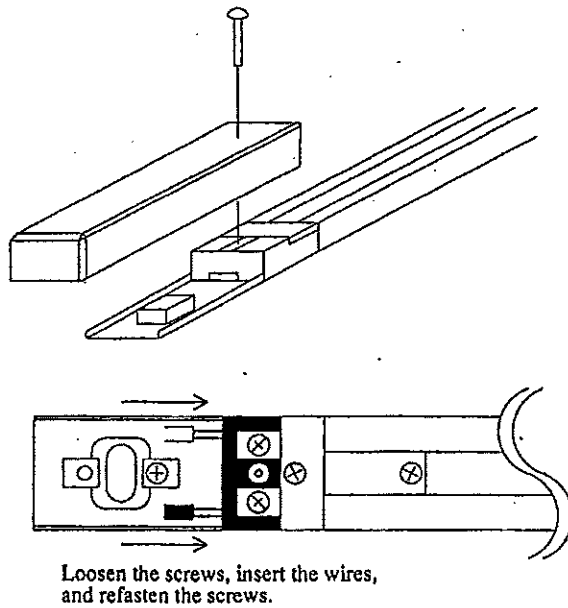

Fig. 6.7 j

## 6-8 CONTROL TOWER

Before installing the Control Tower, make sure that wires for the on-PTV monitor, speaker and spotlight are put through the Wire Duct.

- ① By using 2 tapping screws, secure the Wire Duct at the left-hand rear portion of the Billboard of Seat No. 1 (Fig. 6.8 a).

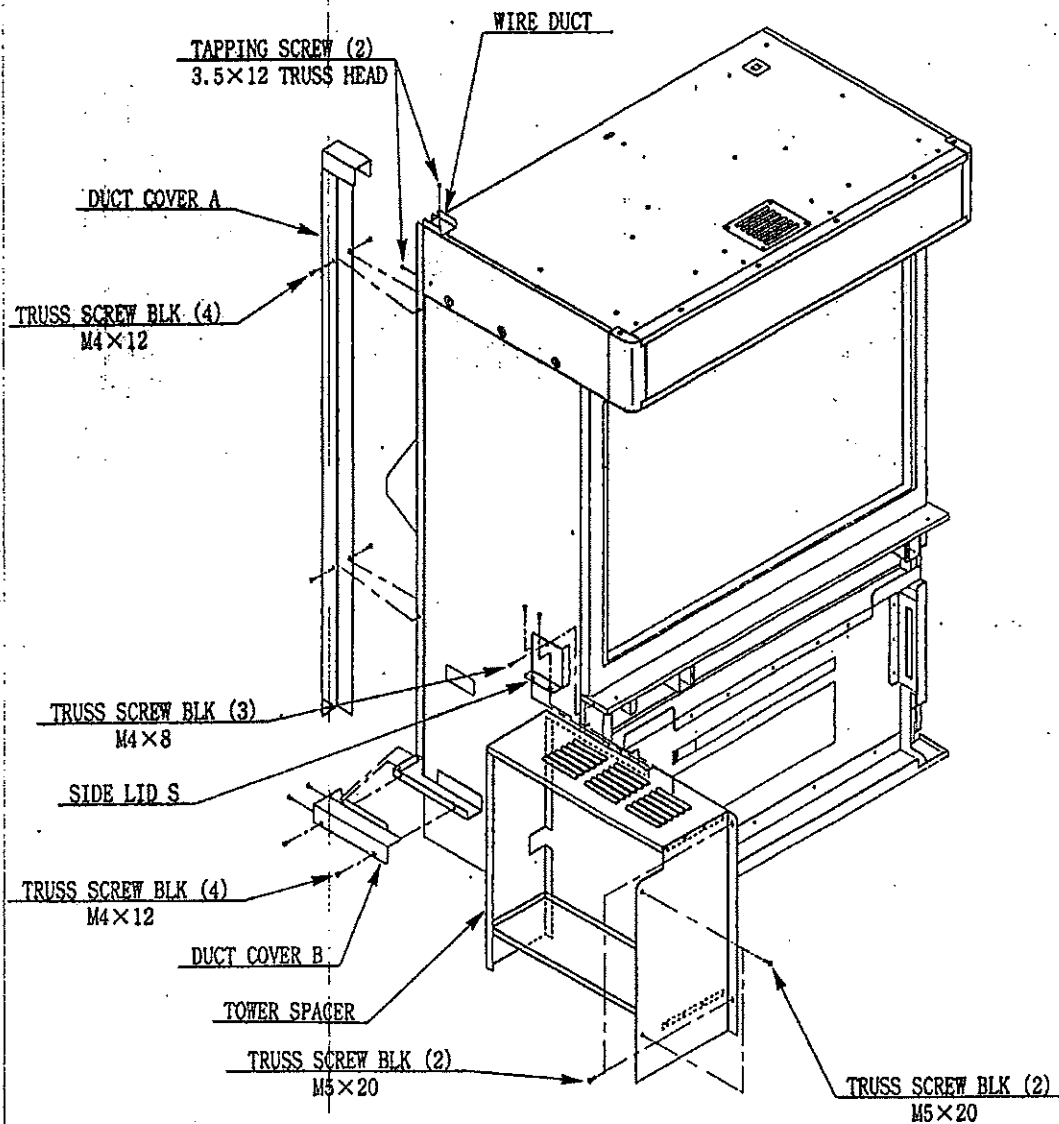

Fig. 6.8 a

- ② After putting wires through the wire DUCT, secure Duct Cover A and B with screws.
- ③ Secure the Tower Spacer on the left-hand side of the Front Cabi of Seat No. 1 by using the 2 Truss Screws. At this time, pay attention so as not to catch wires. Secure Side Lid S on the Tower Spacer.

- ④ Connect wires to the Connector Panel at the rear of the Control Tower. After wiring connections, apply the Tower against the Tower Spacer and secure the Tower with 2 truss screws. At this time, put extra wire portions in the Tower Spacer.
- When performing wiring connections, make sure that the colors of the Connector Panel's sticker display, wire labels and connectors correspond with each other. If connections are made incorrectly, a different seat's on-screen CCD camera images may appear on the monitor or a different seat's Entry Lamp may light up, so be very careful of this point (Fig. 6.8 b).

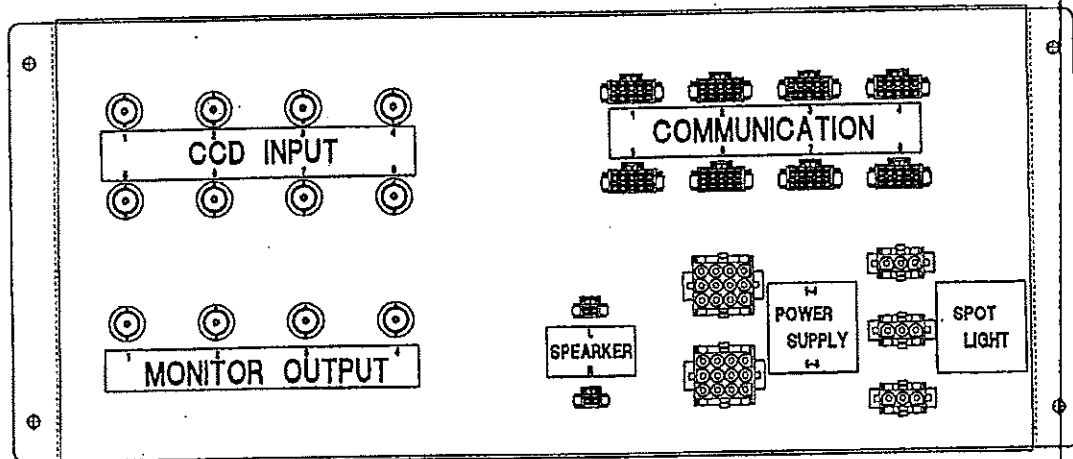
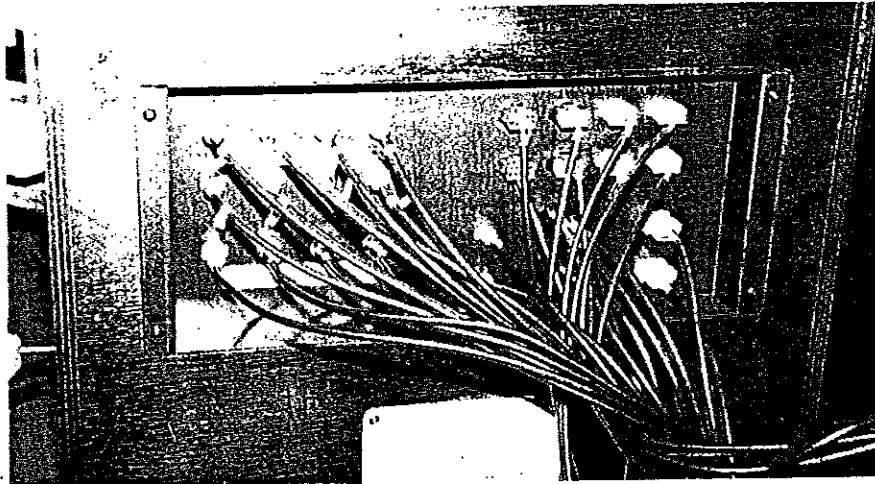

Fig. 6.8 b

## 6-9 CONNECTION TO INDOOR POWER SUPPLY

Connect the indoor power supply to the Control Tower side's BREAKER BOX. Performing this work without the technical personnel qualified for the electrical work is not allowed in Japan. In foreign countries, the work must be performed by such suitably qualified personnel or by those who have sufficient knowledge of electrical work. When carrying out the work, be very careful so as to avoid accidents.

Since the indoor power source varies depending on each installation location, note that herein, explanations are given as regards only the connections in the BREAKER BOX.

**CAUTION!** At the time of shipment from the factory, the timer in the BEAKER BOX is appropriately set. Do not change the timer setting. Changing the timer setting may cause damage to the indoor power source.

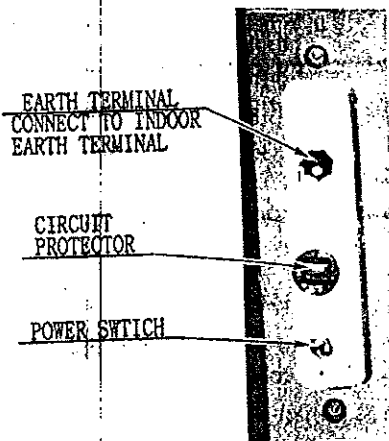

Fig. 6.9 a AC UNIT

- ① Ground the earth. The AC unit of each Front Cabi has an earth terminal (Fig. 6.9 a). Pay careful attention and make sure that the earth wire is not exposed in the passage, etc. in a manner so as to be dangerous.
- ② To prevent accidents, make sure that the power board SW BREAKER of the indoor power source is OFF.
- ③ Check to see that the 2 BREAKERS (16A and 60A) in the BREAKER BOX are OFF.
- ④ Pull in the power supply cable (to be connected to the power supply) and Compressor Connection Cable through the hole positioned underneath the BREAKER BOX.
- ⑤ As shown in Fig.6.9 b, make connection to each terminal.

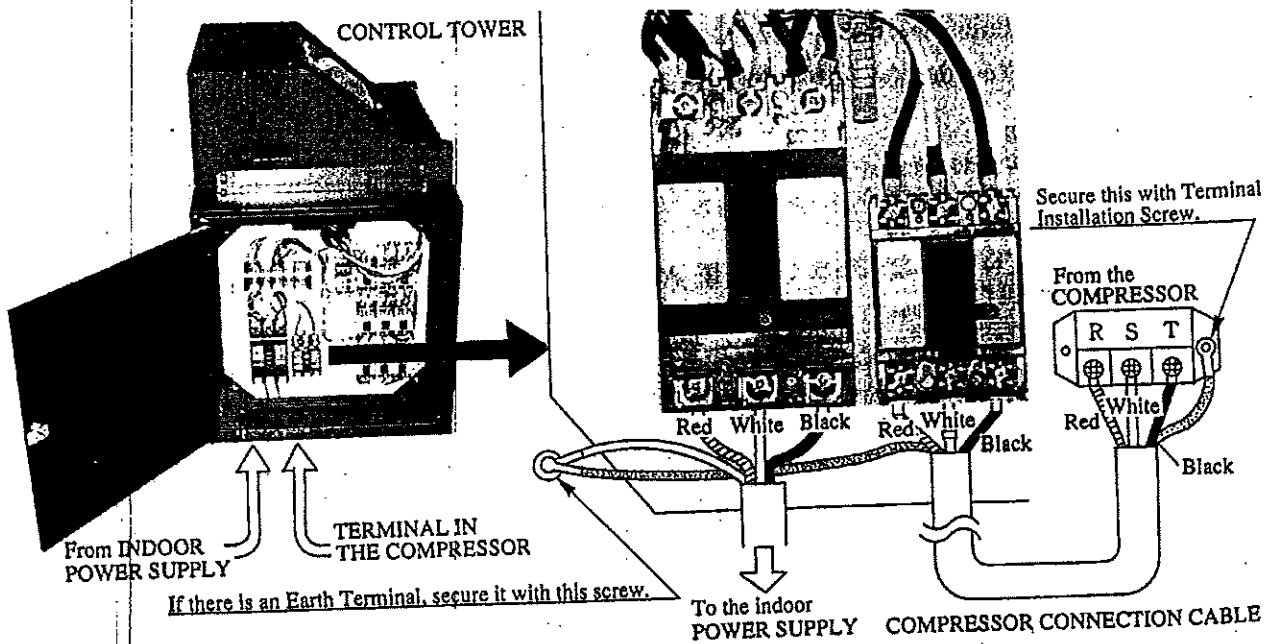

Fig. 6.9 b CONNECTION BETWEEN BREAKER BOX AND POWER SUPPLY

## 7. PRECAUTIONS TO BE HEEDED WHEN TURNING THE POWER ON.

This machine is not playable immediately after the power switch is turned on. In order to protect the indoor power supply, each component unit is set to be powered one after another in differentiated timing. Also note that it takes approximately one minute after the compressor is actuated and until it attains sufficient  $\text{kgf/cm}^2$  to allow game to be played. As such, it takes approximately one minute to be ready for operation after the Main SW is turned ON.

### 7-1 PROCEDURE FOR TURNING THE POWER ON

Normally, when turning power ON/OFF at the time of commencing/finishing the daily operation, use the BREAKER (mentioned in ⑦ of the following procedure) as the main power switch. Turn the power in accordance with the following procedure in order to ensure that the machine functions in normal state as per its specified performance and that the operation is safely performed.

Unless said procedure is followed, the indoor power supply may be damaged or the machines that utilize the identical indoor power supply may be adversely affected.

**CAUTION!** The timer in the BREAKER BOX is appropriately set at the time of shipment. Do not change the timer setting. Changing the setting may cause damage to the indoor power supply.

- ① Make sure that there is no person or no foreign article in the periphery of the machine.
- ② Ensure that the dewatering tubes of the COMPRESSOR are connected to the containers of drain water. Be sure to check the quantity of drain water in the container.
- ③ Make sure that the power switch of each Seat's Front Cabi is ON (Fig. 6-10 a).
- ④ Ensure that the COMPRESSOR's operation switch is ON.
- ⑤ Make sure that the BREAKER SW of the indoor power supply is ON.
- ⑥ Ensure that the 16A BREAKER in the BREAKER BOX is ON.
- ⑦ Turn the 60A BREAKER in the BREAKER BOX on.

In the case where a ventilation device is available at the installation location of the COMPRESSOR, be sure to activate it.

### 7-2 SEQUENTIAL ORDER OF THE ACTUATION AT THE TIME OF TURNING THE POWER ON

The CONTROL TOWER & COMPRESSOR, odd number Seats, and even number Seats are respectively powered one after another, i. e., immediately, 15 seconds, and 30 seconds after the main power switch (60A BREAKER) is turned ON. Since the Spotlight is connected with the CONTROL TOWER, it will light up immediately after the main power switch is turned ON.

When each Seat is powered, the machine automatically starts network check. The PTV screen will display that the check is currently being performed. This check will last 30 seconds at the most.

When the Compressor is powered, the Compressor Motor is activated and the pressure will be increased to the set pressure ( $7.0 \sim 8.5 \text{ kgf/cm}^2$ ). It takes approximately 55 seconds to attain the set pressure. Thus, game play is allowed approximately one minute after the Main SW is turned ON.

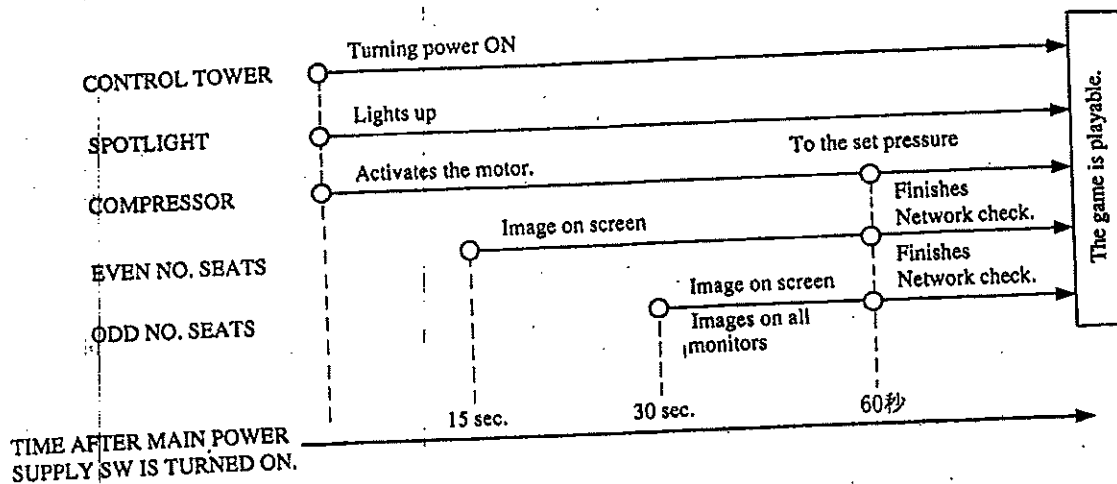

Fig. 7 FUNCTIONING AT THE TIME OF TURNING THE POWER ON

### 7-3 FUNCTIONING CHECK SHEET

- Immediately after the main power SW is turned ON, is the Compressor's motor activated?
- Immediately after the Main Power SW is turned ON, does the Spotlight light up?
- 15 seconds after the main power switch is turned ON, is any image projected on each odd number Seat's PTV screen?
- 30 seconds after the main power switch is turned ON, is any image projected on each even number Seat's PTV screen?
- After all Seats are powered, is any image projected on each monitor?
- Is the network check started?
- 60 seconds after the main power switch is turned ON, are all of the network checks finished?
- 60 seconds after the main switch is turned ON, does the COMPRESSOR's PRESSURE GAUGE point the preset value of 7.0~8.5 kgf/cm<sup>2</sup>?
- Does the COMPRESSOR vibrate or emit irregular sound?
- Does the Regulator's Pressure Gauge (for setting the preset pressure) point 5 kgf/cm<sup>2</sup>?



## 8. PRECAUTIONS TO BE HEEDED WHEN IN OPERATION

This is a large-sized and complex machine. Even when accurately assembled and functioning satisfactorily, if it is not operated and maintained correctly, problems may occur. In order to ensure the operation to be safely and effectively performed, comply with the following instructions and be sure to carry out the periodic inspections herein stated.

### < 1 > DEWATERING

Dewatering from the COMPRESSOR needs to be carried out for this machine. The per day maximum total dewatering quantity for the 4P type is 1.5 liters and for the 8P type, 3 liters. The drain water is discharged mostly from the COMPRESSOR constantly during the machine's operation.

### < 2 > BREAKER BOX TIMER SETTING CHANGE IS PROHIBITED.

Do not change the BREAKER BOX TIMER setting. The setting change may cause damage to the indoor power supply.

### < 3 > AIR DRIVE SYSTEM ADJUSTMENT CHANGE IS PROHIBITED.

The Air Drive System serves to drive and move the Seats by regulating (with each Seat's Speed Controller) the air pressure which has been boosted by the Compressor. The Speed Controller of each Seat is appropriately adjusted at the factory. Do not make any further adjustment without good reason. Changing the adjustment may cause the moving speed to become slow and machine durability to decrease.

### < 4 > SAFETY IN THE PERIPHERY OF THE CONTROL TOWER

The Control Tower is provided with various control devices in addition to the EMERGENCY STOP SW. Take the necessary measures such as assigning full-time attendant personnel so as to ensure that unauthorized personnel refrain from making contact with the machine, and ensuring that the Service Panel is always kept locked.

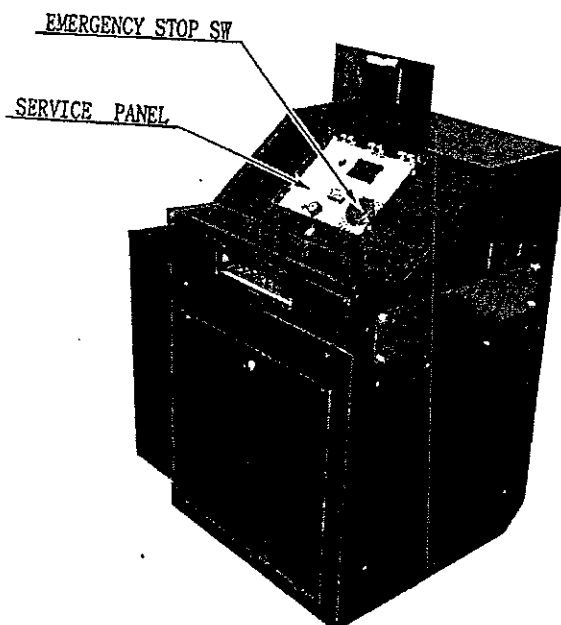

Fig. 8.1 CONTROL TOWER

### < 5 > ENSURING THAT THE HAZARD PREVENTION DEVICE IS FUNCTIONING

Periodically inspect the EMERGENCY STOP SW of the hazard prevention device and make sure that it is in normal functioning condition.

Pressing the EMERGENCY STOP SW causes the movements of all Seats to cease, with "SAFE GUARD" (displayed on the PTV screens of all Seats) flashing (Fig. 8.1).

The emergency stop command can be cancelled by pressing the EMERGENCY STOP SW again. Three seconds after the EMERGENCY STOP is cancelled, the Seats start moving.

Note that what stops is the Seat movements only and not the game or steering wheel reaction.

## 9. HOW TO PLAY

The following explanations apply to the case where the Control Tower is not employed. When using the Control Tower, the start procedure is different. For details, refer to Section 11.

- ① Sit in the Seat. The seat position can be adjusted forward and backward. For adjustments, pull the lever which is positioned on the lower left-hand side (facing the PTV screen) of the seat.
- ② The coin chute door is located on the left-hand side in the front of the cabinet. Insert a coin into the corresponding coin entry slot and press the start button. 3 courses appear on the screen in the sequence of Beginner, Advanced and Expert starting from the left.
- ③ At this time, "WELCOM A "VS." COMPETITOR," and "14 SEC. TO START" (which counts down the starting time) are displayed on the other player's monitor. The person who wishes to compete with the first player should insert a coin into the coin entry slot for his seat within the 14 seconds and press the start button.
- ④ By turning the steering wheel, choose a course and make the selection effective by stepping on the Accelerator. The course selection is determined by the majority of the players participating in the "vs." competition race and not by the person who pressed the start button first.
- ⑤ SHIFT CHANGE SELECTION screen appears. Choose AUTO or MANUAL by turning the steering wheel and make the selection effective by stepping on the Accelerator. This selection is made by each Seat independently. While pressing the start button, if you step on the Accelerator, only the "vs." competitor's car appears and other competitor cars will not appear. This is also determined by the majority of the players participating in the "vs." competition.
- ⑥ When AUTO or MANUAL is determined, the game starts. Choosing Beginner course results in a rolling start, the same as in the Daytona race. When the Advanced or Expert course is chosen, be sure to step on the Accelerator to start the machine.
- ⑦ The on-screen upper right-hand side, below the upper right, the upper middle, below the upper middle, the upper left-hand side and the lower right respectively indicates the player's present position, where other cars are, time limit, speed & tachometer, lap time and course map.

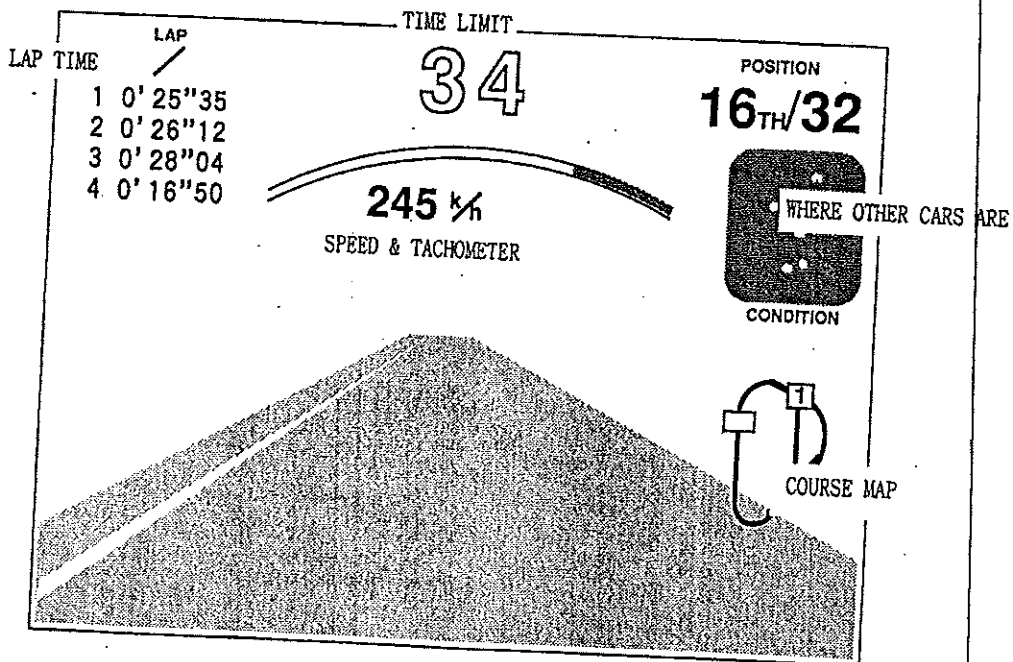

Fig. 9.1

## 10. EXPLANATION OF TEST AND DATA DISPLAY

By operating the switch unit, periodically perform the tests and data check. When installing the machine initially or collecting cash, or when the machine does not function correctly, perform checking in accordance with the explanations given in this section. The following shows tests and modes that should be utilized as applicable.

### CAUTIONS TO BE HEEDED WHEN USING THE TEST MODE:

Exiting from the test mode causes the unit to perform the network check automatically. During this time, all of the linked units will not allow the game to be played in normal status. Therefore, be sure not to enter the test mode if any one of the units is in play. On the other hand, if even one unit is in the mode, make sure that other machines are not in play.

TABLE 10.1 EXPLANATION OF TEST MODE

ITEMS	DESCRIPTION	REFERENCE SECTIONS
INSTALLATION OF MACHINE	When the machine is installed, perform the following: 1. Check to see that each setting is as per standard setting made at the time of shipment. 2. In the INPUT TEST mode, check each SW and VR. 3. In the OUTPUT TEST mode, check each of lamps. 4. In the SELF-TEST mode, check ICs on the IC Board.	10-4, 10-5 10-6, 10-10 10-7 10-10, 10-11
MEMORY	Choose MEMORY TEST in the MENU mode to allow the MEMORY test to be performed. In this test, PROGRAM RAMs, ROMs, and ICs on the IC Board are checked.	10-10, 10-11
PERIODIC SERVICING	Periodically perform the following: 1. MEMORY TEST 2. Ascertain each setting. 3. In the INPUT TEST mode, test the CONTROL device 4. In the OUTPUT TEST mode, check each of lamps.	10-10, 10-11 10-4, 10-5 10-6, 10-10 10-7
CONTROL SYSTEM	1. In the INPUT TEST mode, check each SW and VR. 2. Adjust or replace each SW and VR. 3. If the problem can not be solved yet, check the CONTROL's moves.	10-6, 10-10 13, 14, 15
MONITOR	In the MONITOR ADJUSTMENT mode, check to see if the MONITOR adjustment is appropriately made.	10-7 20
IC BOARD	1. MEMORY TEST 2. In the SOUND TEST mode, check the sound related ROMs.	10-10, 10-11 10-9
DATA CHECK	Check such data as game play time and histogram to adjust the difficulty level, etc..	10-3

## 10-2 TEST MODE

- The Test Menu allows the functioning of each part of the Cabinet to be checked, the PROJECTOR to be adjusted, and the coins and game related various settings to be performed.
- Press the TEST SWITCH to cause the following Test Menu to be displayed on the monitor. (FIG. 10. 2)
- Press the SERVICE SWITCH until the pointer ">>" is moved to the desired item. Also, note that pressing VR1 (red) causes the arrow to move downward and pressing VR4 (green) causes the arrow to move upward.
- Bring the pointer ">>" to the desired test item and press either the TEST SWITCH or START SWITCH to cause the selected item's test to start.

```
TEST MODE
BOOKKEEPING
GAME SYSTEM
COIN ASSIGNMENT
INPUT TEST
OUTPUT TEST
DRIVE BD TEST
SOUND TEST
TGP TEST
MEMORY TEST
BACKUP RAM CLEAR
>> EXIT

GREEN : CURSOR UP
RED   : CURSOR DOWN
START : TO SELECT
```

FIG. 10. 2 TEST MENU

After the test is complete, move ">>" to "EXIT" and press the TEST SWITCH or START SWITCH to return to the Game Mode.

```

      BOOKKEEPING

TOTAL PLAY GAMES xxxxxxxxGAMES
BEGINNER COURSE xxxxxxxxGAMES
                  GOALS xxxxxxxx
AVERAGE PLAY TIME  xxMxxS
FASTEST GOAL TIME  xxMxxS

ADVANCED COURSE  xxxxxxxxGAMES
                  GOALS xxxxxxxx
AVERAGE PLAY TIME  xxMxxS
FASTEST GOAL TIME  xxMxxS

EXPERT COURSE  xxxxxxxxGAMES
                GOALS xxxxxxxx
AVERAGE PLAY TIME  xxMxxS
FASTEST GOAL TIME  xxMxxS

START : TO EXIT
RED   : TO OTHER PAGE

```

FIG. 10. 3b BOOKKEEPING

- BEGINNER COURSE: Beginner course's game play frequency
  - ADVANCED COURSE: Advanced course's game play frequency
  - EXPERT COURSE: Expert course's game play frequency
  - GOALS: Total number of GOALS of each course.
- Press the TEST SW or START SWITCH to return to the MENU mode screen.
  - Press VR1 (red) to proceed to the other page.

## 10-5 COIN ASSIGNMENT

The "COIN ASSIGNMENTS" mode permits you to set the start number of credits, as well as the basic numbers of coins and credits. This mode expresses "how many coins correspond to how many credits."

COIN ASSIGNMENT	
CREDIT TO START	1CREDIT(S)
COIN/CREDIT SETTING #1	
CHUTE1	1COIN 1CREDIT
CHUTE2	1COIN 1CREDIT
>> EXIT	
GREEN	: CURSOR UP
RED	: CURSOR DOWN
YELLOW	: MODE UP
BLUE	: MODE DOWN
START	: TO SELECT

FIG. 10.5 COIN ASSIGNMENTS

- CREDIT TO START      Number of credits required for starting game (1~5 credits are selected.)
- COIN/CREDIT SETTING      "How many coins correspond to how many credits."  
In this machine, selection as per Table 10.2 is possible.

### SETTING CHANGE PROCEDURE

- ① Press the SERVICE SW or VR1 (red), or VR 4 (green) to move the arrow (>>) to the desired item.
- ② Choose the desired setting change item by using any one of VR2 (blue), VR3 (yellow), TEST SW and START SWITCH.
- ③ To return to the MENU mode, move the arrow to EXIT and press the TEST SW or START SWITCH.

TABLE 10. 2 COIN/CREDIT SETTING (COIN CHUTE COMMON TYPE)

NAME OF SETTING	FUNCTIONING OF COIN CHUTE #1		FUNCTIONING OF COIN CHUTE #2	
SETTING #1	1 COIN	1 CREDIT	1 COIN	1 CREDIT
SETTING #2	1 COIN	1 CREDIT	1 COIN	2 CREDITS
SETTING #3	1 COIN	1 CREDIT	1 COIN	3 CREDITS
SETTING #4	1 COIN	1 CREDIT	1 COIN	4 CREDITS
SETTING #5	1 COIN	1 CREDIT	1 COIN	5 CREDITS
SETTING #6	1 COIN	2 CREDITS	1 COIN	2 CREDITS
SETTING #7	1 COIN	2 CREDITS	1 COIN	5 CREDITS
SETTING #8	1 COIN	3 CREDITS	1 COIN	3 CREDITS
SETTING #9	1 COIN	4 CREDITS	1 COIN	4 CREDITS
SETTING #10	1 COIN	5 CREDITS	1 COIN	5 CREDITS
SETTING #11	1 COIN	6 CREDITS	1 COIN	6 CREDITS
SETTING #12	2 COINS	1 CREDIT	2 COINS	1 CREDIT
SETTING #13	2 COINS	1 CREDIT	1 COIN	1 CREDIT
SETTING #14	2 COINS	1 CREDIT	1 COIN	2 CREDITS
SETTING #15	1 COIN	1 CREDIT	1 COIN	1 CREDIT
	2 COINS	3 CREDITS	2 COINS	3 CREDITS
SETTING #16	1 COIN	1 CREDIT	1 COIN	3 CREDITS
	2 COINS	3 CREDITS		
SETTING #17	3 COINS	1 CREDIT	3 COINS	1 CREDIT
SETTING #18	4 COINS	1 CREDIT	4 COINS	1 CREDIT
SETTING #19	1 COIN	1 CREDIT	1 COIN	1 CREDIT
	2 COINS	2 CREDITS	2 COINS	2 CREDITS
	3 COINS	3 CREDITS	3 COINS	3 CREDITS
	4 COINS	5 CREDITS	4 COINS	5 CREDITS
SETTING #20	1 COIN	1 CREDIT	1 COIN	5 CREDITS
	2 COINS	2 CREDITS		
	3 COINS	3 CREDITS		
	4 COINS	5 CREDITS		
SETTING #21	5 COINS	1 CREDIT	5 COINS	1 CREDIT
SETTING #22	3 COINS	1 CREDIT	1 COIN	2 CREDITS
	5 COINS	2 CREDITS		
SETTING #23	2 COINS	1 CREDIT	2 COINS	1 CREDIT
	4 COINS	2 CREDITS	4 COINS	2 CREDITS
	5 COINS	3 CREDITS	5 COINS	3 CREDITS
SETTING #24	2 COINS	1 CREDIT	1 COIN	3 CREDITS
	4 COINS	2 CREDITS		
	5 COINS	3 CREDITS		
SETTING #25	1 COIN	1 CREDIT	1 COIN	1 CREDIT
	2 COINS	2 CREDITS	2 COINS	2 CREDITS
	3 COINS	3 CREDITS	3 COINS	3 CREDITS
	4 COINS	4 CREDITS	4 COINS	4 CREDITS
	5 COINS	6 CREDITS	5 COINS	6 CREDITS
SETTING #26	1 COIN	1 CREDIT	1 COIN	6 CREDITS
	2 COINS	2 CREDITS		
	3 COINS	3 CREDITS		
	4 COINS	4 CREDITS		
	5 COINS	6 CREDITS		
SETTING #27	FREE PLAY		FREE PLAY	

## 10-6 INPUT TEST

When INPUT TEST is selected, the projector will show the following, allowing you to watch the status of each switch and the value of each V. R. of the CONTROL PANEL. On this screen, periodically check the status of each switch & V. R.

- By pressing each switch, if the display on the right-hand side of the name of each switch changes to ON from OFF, the SW and the wiring connections are satisfactory.
- To check CHUTE 1 & CHUTE 2 coin switches, open the COIN CHUTE DOOR and insert a coin(s) from the coin entry.
- To return to the MENU mode, simultaneously press VR1 & VR2, or press the TEST SW.

INPUT TEST			
CHUTE1	OFF	CHUTE2	OFF
SHIFT1	OFF	SHIFT2	OFF
SHIFT3	OFF	SHIFT4	OFF
VR1	OFF	VR2	OFF
VR3	OFF	VR4	OFF
START	OFF		
TEST-SW	OFF	SERVICE-SW	OFF
HANDLE	xxxH		
ACCEL	xxxH		
BRAKE	xxxH		

RED & BLUE : TO EXIT

FIG. 10.6 INPUT TEST

An appropriate value of each V. R. is as follows:

HANDLE:	Under 2DH left	← 7D~83H → (Centering position)	Over D3H right
ACCEL:	Under 30H	→	Over C0H
BRAKE:	Under 30H (the pedal released)	→	Over C0H (the pedal stepped)



## 10-8 DRIVE BD TEST

This test is comprised of 2 screens of which one allows the Steering Wheel Reaction Mechanism to be checked, and the other enabling Seat Moving Mechanism to be checked. Select "DRIVE BD TEST" on the MENU screen (Fig. 10.2) to have the screen (as shown in Fig. 10.8 a) appear. By using the SERVICE SW or VR1 (red) or VR4 (green), bring the arrow (>>) to the desired test item.

To return to the MENU screen (Fig. 10.2), bring the arrow (>>) to EXIT and press either TEST SW or START SW.

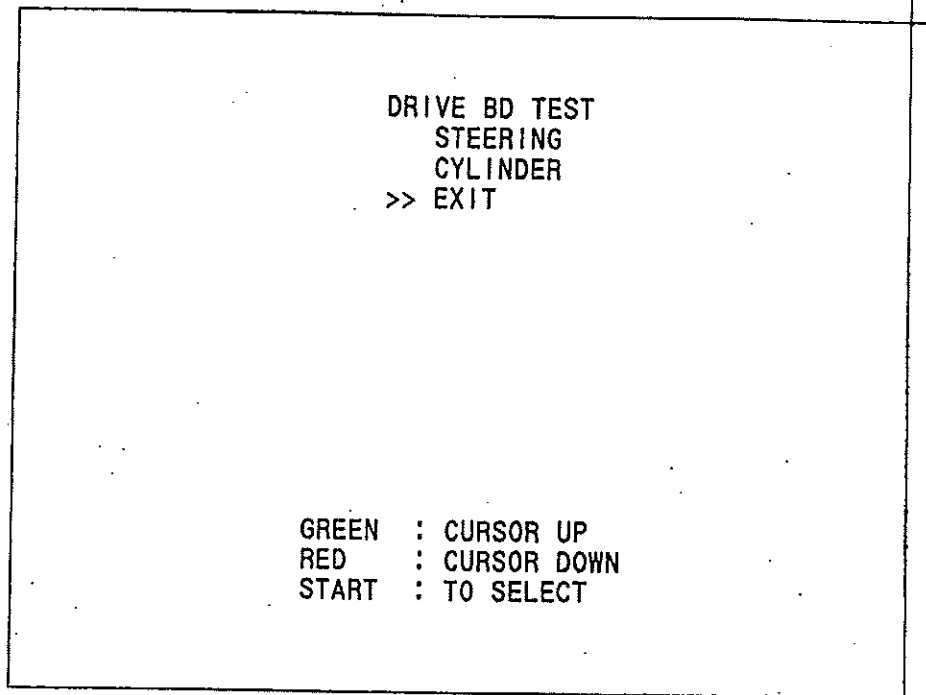

FIG. 10.8 DRIVE BD TEST

**DIP SW SETTING TABLE**

The setting of DIP SW 2 on the DRIVE BD allows the handle's weight (i.e., "feeling"), etc. to be set. Note that normally, Nos. 4 to 8 of DIP SW 2 are to be off, and that DIP SW 1 is not used. SW Nos. 1 ~ 8 are all to be OFF.

The DRIVE BD is mounted on the ASSY ELEC. Refer to 23-1 when changing the settings. To change DIP SW settings, make sure that the power is OFF. Performing the setting change work with the power ON may cause electric shock accident. Changing the settings with the power ON does not allow such new settings to be activated.

The handle's reaction mechanism is subject to a secular change. When the reaction becomes lighter, change the settings for Nos. 1 to 3 of DIP SW 2.

**DIP SW 2 SETTING**

NOTE: The shaded portion refers to the setting at the time of shipment. Make sure that SW Nos. 4, 7 and 8 are always OFF.

1	2	3	FUNCTION
OFF	OFF	OFF	Light
ON	OFF	OFF	
OFF	ON	OFF	
ON	ON	OFF	
OFF	OFF	ON	
ON	OFF	ON	
ON	ON	ON	
			Heavy

**DRIVE BD ERROR DISPLAY**

When malfunctioning occurs in the DRIVE BD, testing will not be performed even if DRIVE BD TEST is selected. In this case, the error No. will be displayed by the 7-SEG display on the DRIVE BD.

Also, when a POWER-ON CHECK ERROR occurs, the 7-SEG. display data repeatedly flashes. First check the handle mecha's V. R., the motor, clutch, etc.

```

DRIVE BD TEST CYLINDER
CYLINDER LEFT LOWER OFF
CYLINDER LEFT UPPER OFF
CYLINDER RIGHT UPPER OFF
CYLINDER RIGHT LOWER OFF
QUICK BREATH LEFT OFF
QUICK BREATH RIGHT OFF
READY FOR TOWER OFF
CCD PRIORITY OFF
>> EXIT

GREEN : CURSOR UP
RED : CURSOR DOWN
START : TO SELECT

```

Fig. 10.8 c CYLINDER TEST

Choosing "CYLINDER" in Fig. 10.8a causes Fig. 10.8 c screen to be displayed. This screen allows Seat movement mechanism, etc., to be checked. Move the arrow (>>) by using the SERVICE SW or VR SW1 (red) or VR SW4 (green). Check if the Seat movements are in accordance with the setting pointed by the arrow and the ENTRY LAMP lights up. On this screen, periodically check if the movements are in compliance with the settings.

- CYLINDER LEFT LOWER Moves the lower left CYLINDER.  
ON: Shrinks (Seat's left side is lowered).  
OFF: Stretches (Seat's left side is raised).
- CYLINDER LEFT UPPER Moves the upper left CYLINDER.  
ON: Stretches (Seat's left side is raised).  
OFF: Shrinks (Seat's left side is lowered).
- CYLINDER RIGHT UPPER Moves the upper right CYLINDER.  
ON: Shrinks (Seat's right side is raised).  
OFF: Shrinks (Seat's right side is lowered).
- CYLINDER RIGHT LOWER Moves the lower right CYLINDER.  
ON: Shrinks (Seat's right side is lowered).  
OFF: Stretches (Seat's right side is raised).
- QUICK BREATH LEFT Opens/closes the quick exhaust valve for the Lower Left CYLINDER. Set this setting to ON, and CYLINDER LEFT LOWER to ON (to shrink) for quick movement. When set to OFF (to stretch), there is no speed change.
- QUICK BREATH RIGHT Opens/closes the quick exhaust valve for the Lower Right CYLINDER. Set this to ON, and CYLINDER RIGHT LOWER to ON (to shrink) for quick movement. When set to OFF (to stretch), there is no speed change.
- READY FOR TOWER This is the signal to the Control Tower. Setting this to ON causes the specific Seat's Entry Lamp on the Control Tower to light up.
- CCD PRIORITY CCD CAMERA's PRIORITY DISPLAY  
When set to ON, the specific Seat's images projected by the CCD camera appears on all of the above-PTV monitors.
- EXIT To return to the MENU screen (Fig.10.8 a).

## 10-9 SOUND TEST

Choosing SOUND TEST causes the following mode to appear on the screen. This allows the desired sound (BGM, announcement and sound effects) to be chosen and heard. Enables the SOUND BD, AMP BD and each speaker to be checked.

Press the SERVICE SW or VR1 (red) or VR4 (green) and bring the arrow (>>) to the desired sound item to be tested. Pressing the TEST SW or START SWITCH allows the selected sound test to be performed.

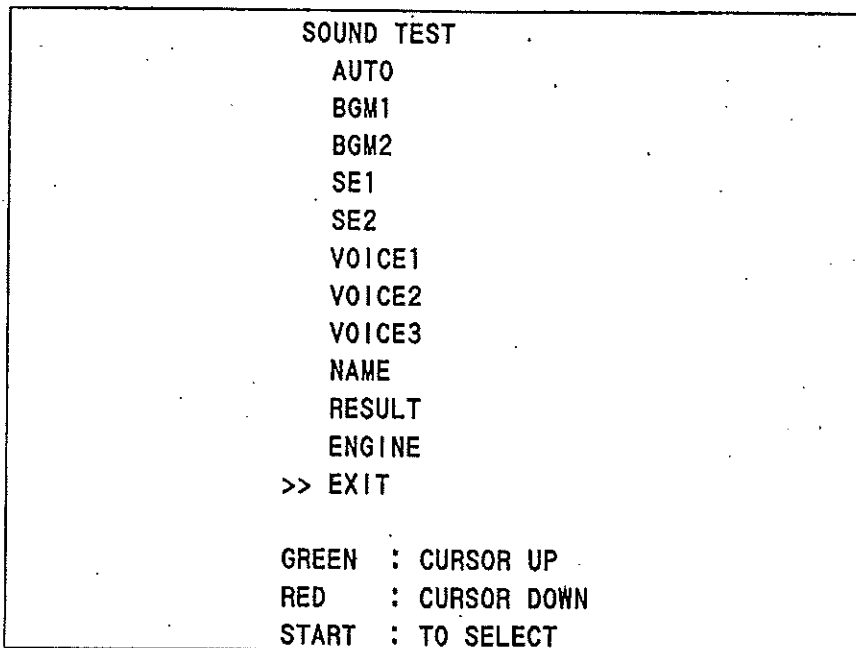

FIG. 10.9 SOUND TEST

- AUTO Auto play covering from BGM to RESULT.  
Bring the arrow to this item and press TEST SW or START SWITCH to cause SOUND TEST covering from BGM to RESULT to be performed automatically and repeatedly. Press the TEST SW or START SWITCH again to exit from the AUTO test and return to the above screen.
- BGM Background music during game.
- SE Sound effects during game.
- VOICE Announcement and comment during game.
- NAME Announcement and comment during name entry.
- RESULT Announcement during the display of the results.
- ENGINE Engine/Slip/Brake sounds can be emitted by using the ACCEL. pedal, HANDLE pedal and BRAKE pedal respectively.
- EXIT Causes the menu mode to return on to the screen.

## 10-10 TGP TEST

TGP TEST		
IC. 47	GOOD	GOOD
IC. 56	GOOD	GOOD
IC. 60	GOOD	GOOD
IC. 64	GOOD	GOOD

START : TO EXIT

In this test, TGP (on-screen display related IC) is checked. As shown at the left, if "GOOD" is displayed for all, it is satisfactory. Press TEST SW or START SWITCH to return to the menu screen.

FIG. 10.10 TGP TEST

## 10-11 MEMORY TEST

The MEMORY TEST mode is for checking the on-BD memory IC functioning. "GOOD" is displayed for normal ICs and "BAD" is displayed for abnormal ICs.

MEMORY TEST		
IC. 6 GOOD	IC. 7 GOOD	IC. 8 GOOD
IC. 9 GOOD	IC. 10 GOOD	IC. 11 GOOD
IC. 12 GOOD	IC. 13 GOOD	
IC. 45 GOOD	IC. 46 GOOD	IC. 47 GOOD
IC. 48 GOOD	IC. 49 GOOD	IC. 50 GOOD
IC. 54 GOOD	IC. 55 GOOD	

START TO EXIT

FIG. 10.11 MEMORY TEST

- When the test is completed, if the results are shown as above, it is satisfactory.
- It takes approximately thirty seconds to complete the test. If the period exceeds thirty seconds, this may have been caused by board malfunctioning.
- After finishing the test, pressing the TEST SW or START SWITCH allows the MENU mode to return on to the screen.

## 10-12 BACKUP RAM CLEAR

Clears the contents of BOOKKEEPING.

When clearing, bring ">>" to "YES" and when not clearing, to "NO", by using the SERVICE SW or VR1(red)/VR4(green), and then push the TEST SW or START SWITCH.

When the data has been cleared, "COMPLETED" will be displayed. Bring ">>" to "NO" and press the TEST SW to cause the Menu mode to return on to the screen.

Also, note that the game setting contents are not affected by BACKUP RAM CLEAR operation.

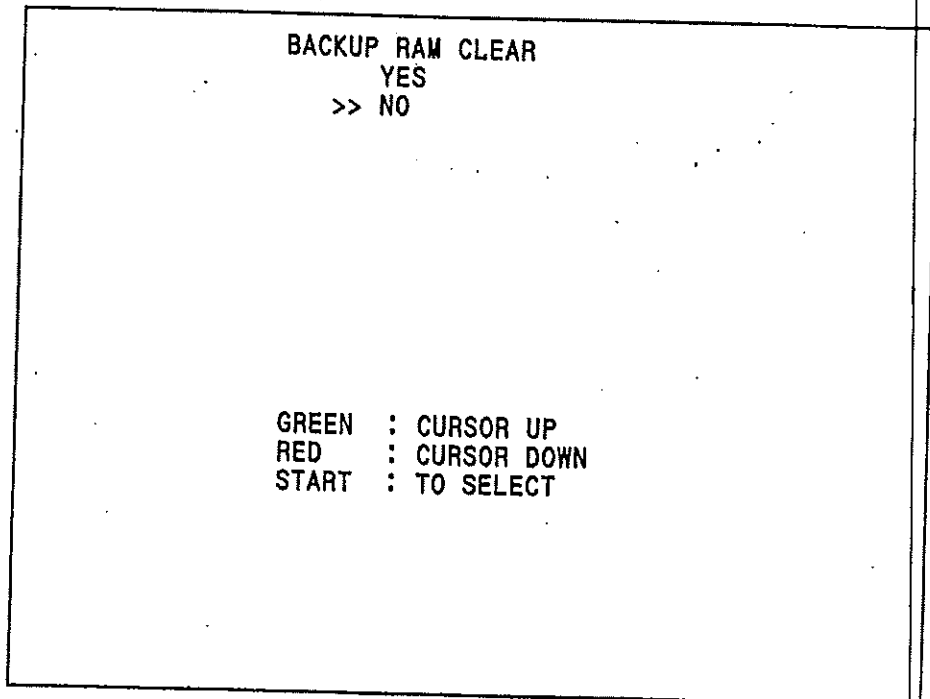

FIG. 10.12 BACKUP RAM CLEAR

● **START**

If any Seat is ready for Entry, pressing this SW causes countdown numerals to disappear from the screen of each cabinet, and Entry to be accepted until the SW is pressed again or Entry for all Seats are completed. To start the game, first make sure via Entry lamp, etc. that everyone who occupies the Seat has completed Entry, and then press the START SW again. If any Seat is in an Entry status or in game, the START SW flashes, and it lights up when countdown is ceased. This switch is not activated unless the MAIN SW is ON.

● **MIC IN**

● **MIC VOL**

This is the volume control for the input terminal and volume adjustment of the microphone for PA (Public Announcement).

**COMPULSORY ENTRY FUNCTION**

For the operation of this game by using the ticket system, select the Seat for game play and let the players start simultaneously by following the procedure below:

- ① When all of the Seat are in ADVERTISE status, insert the key into CONTROL MAIN and turn it to ON.
- ② Make sure that the FUNCTION SW is turned to "ENTRY."
- ③ Select the Seat by pressing the "ENTRY SW" of the Seat desired to start simultaneously. The SW pressed lights up. To cancel, press the ENTRY SW of the Seat again.
- ④ Make sure that players are seated on each selected Seat and they are ready for game start.
- ⑤ Press the START SW, and only the selected Seats start the game.

## 11-2 POWER AMPLIFIER

The Control Tower incorporates a POWER AMPLIFIER of 50W x 2 ch for PA (public announcement)

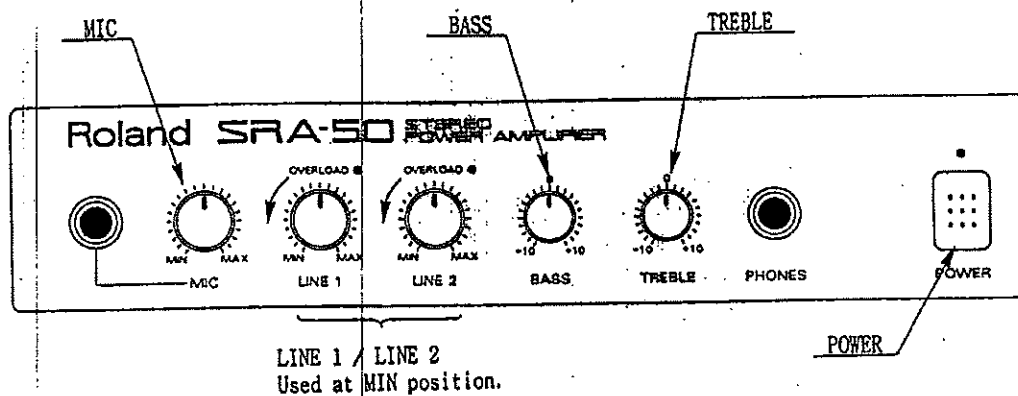

Fig. 11.2 POWER AMPLIFIER

- **POWER**  
This is the Power Supply SW. Make sure that the red indicator above this switch is lit.
- **MIC**  
This adjusts the microphone's input level. This volume control is set at the position slightly before MAX. Normally, use the SERVICE PANEL's volume control to adjust the sound volume.
- **LINE 1 / LINE 2**  
Utilize these at the MIN position.
- **BASS / TREBLE**  
Used for adjusting BASS and TREBLE. Make adjustments as required.



### 11-3 DIP SW

DIP SW1 which is mounted on the Control BD among the IC BDs in the Control Tower allows settings mainly regarding the CCD Camera control to be made. Make sure that all other DIP SWes on the IC BDs are OFF.

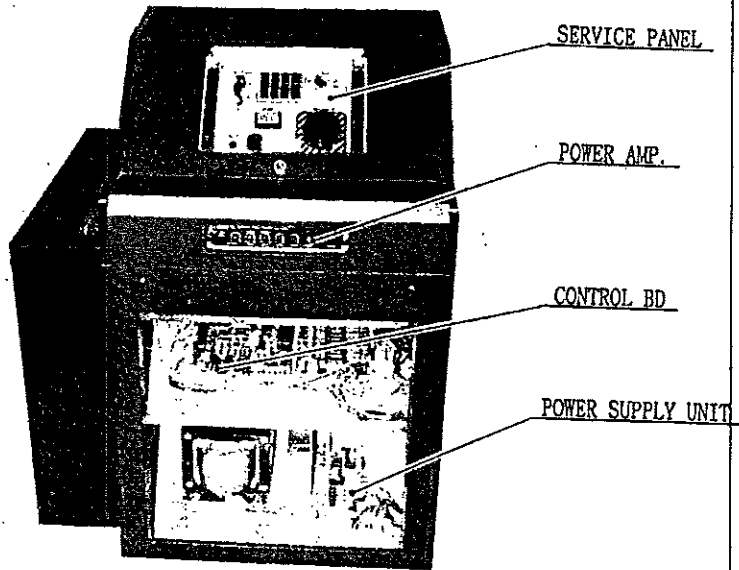

Fig. 11.3 CONTROL TOWER

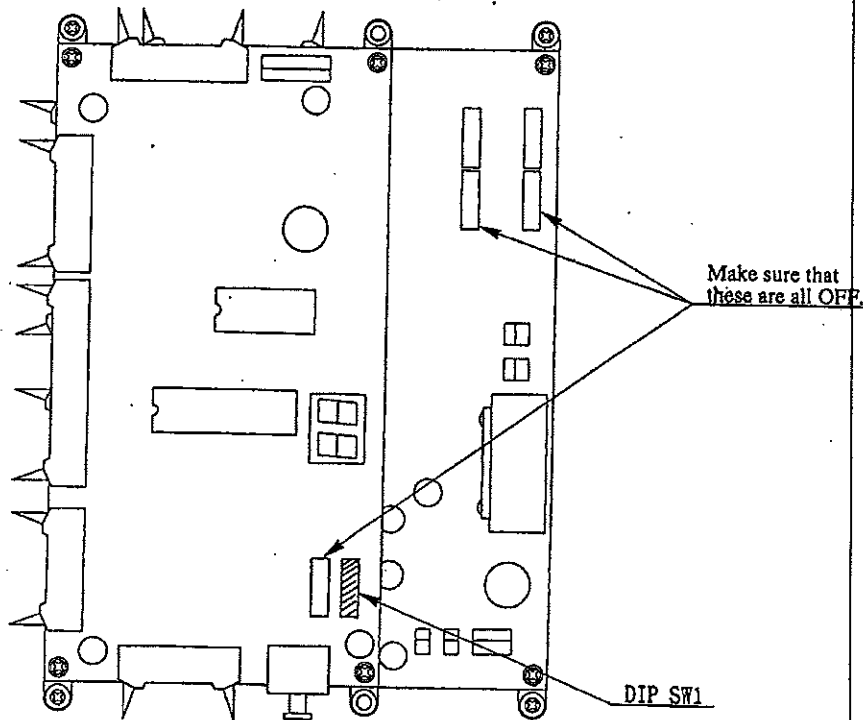

Fig. 11-4 CONTROL BVD

SW1

1, 2 : MONITOR'S OUTPUT PATTERN DURING ADVERTISE MODE

1	2	
OFF	---	EXTERIOR INPUT (SWITCHER BDのIN 10)
ON	OFF	Backward (8>7>6> . . . >1>8>7> . . .)
ON	ON	Forward (1>2>3> . . . >8>1>2> . . .)

3 : NOT USED

4 : SEAT NO. SHIFT

4	
OFF	8P CABI
ON	4P CABI

5~8 : LED DISPLAY SHIFT

5	6	7	8	
OFF	OFF	OFF	OFF	COUNTER DISPLAY
ON	OFF	OFF	OFF	CH 0 (MONITOR 1) SOURCE [1X]
OFF	ON	OFF	OFF	CH 1 (MONITOR 2) SOURCE [2X]
ON	ON	OFF	OFF	CH 2 (MONITOR 3) SOURCE [3X]
OFF	OFF	ON	OFF	CH 3 (MONITOR 4) SOURCE [4X]
ON	OFF	ON	OFF	CH 4 SOURCE [5X]
OFF	ON	ON	OFF	CH 5 SOURCE [6X]
		OTHERS		NOT USED

NOTE: [ ] refers to LED display.

#### 11-4 CHANGING THE DIRECTION OF THE CONTROL TOWER'S SERVICE PANEL

NOTE : In the case where the Control Tower installation space is limited and if it is difficult to operate the Service Panel, the position of the Service Panel can be adjusted by 90 degrees. When performing the work, follow the procedure below:

- ① Open the Service Door on the rear side of the Control Tower and disconnect all of the Connectors which connect Control Tower U and Control Tower L.
- ② Remove the 8 screws which secure Connect Plate A and Connect Plate B to remove Control Tower U (Fig. 11.5).
- ③ Connect the Extension Wire (an accessory) to Control Tower L wire and change the position of the connection with Control Tower U as shown below. Secure the wire with clamps. Make sure that all of the 5 Connectors are connected (Fig. 11.6).

- ④ Change the direction of Control Tower U by 90 degrees, mount it on Control Tower L and secure it to Control Tower L with two Connect Plate A. At this time, be very careful so that Connectors are not caught (Fig. 11.7).
- ⑤ Connect up the Connectors which connect Control Tower U and Control Tower L, and close the Service Door.
- ⑥ Connect the Control Tower to the machinery in accordance with 6-8 and 6-9, and make sure that the Control Tower is functioning in normal operating status. If it does not function satisfactorily, check if Connector connections are appropriately made.

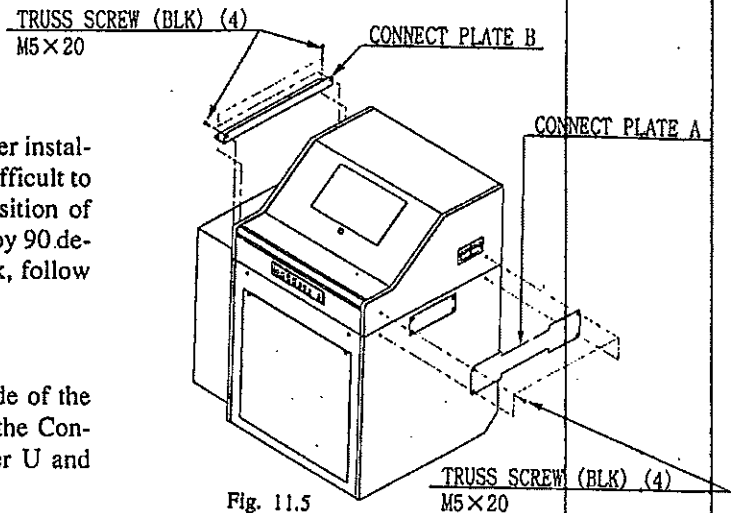

Fig. 11.5

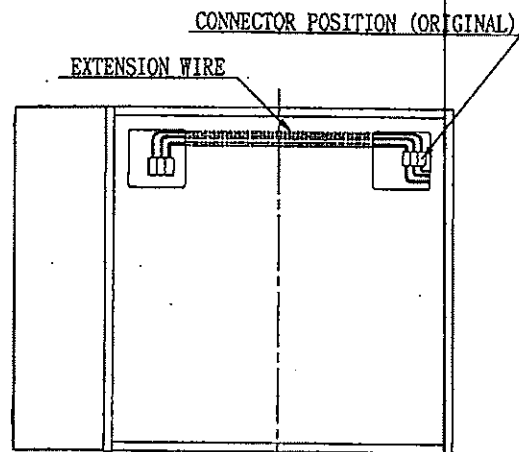

Fig. 11.6

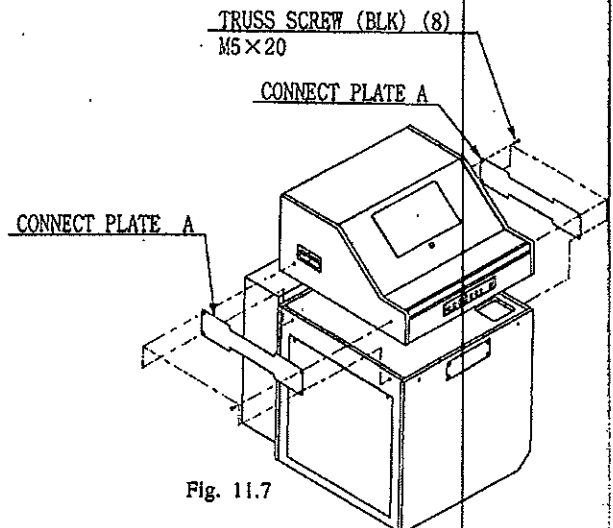

Fig. 11.7

## 12. AIR DRIVE SYSTEM

### Overview of Air Drive System

This machine uses an "air drive system" that drives the Seat by compressed air. In this system, the air compressed by a compressor is stored in tank. By opening and closing a computer-controlled solenoid valve, the compressed air acts on the actuator (air cylinder), which drives the Seat.

Use of compressed air allows quick response unexpected from an electrical system.

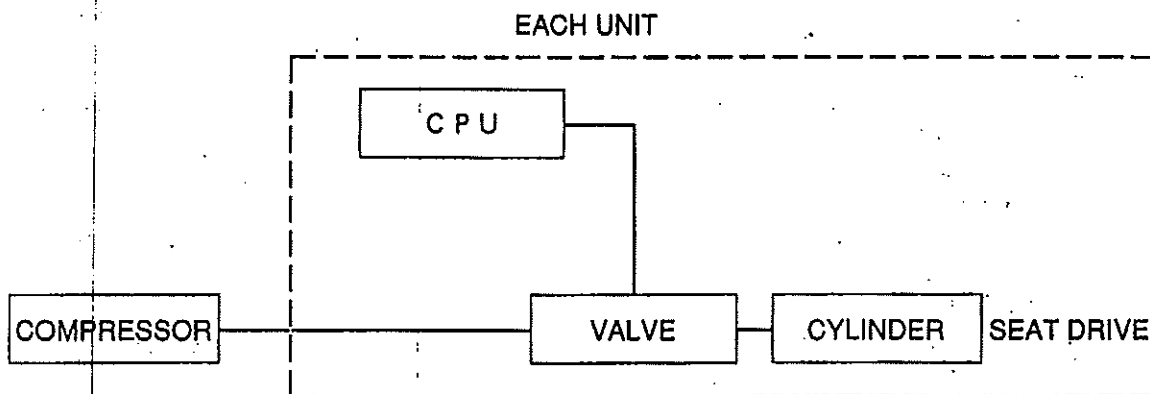

AIR DRIVE SYSTEM SCHEMATIC

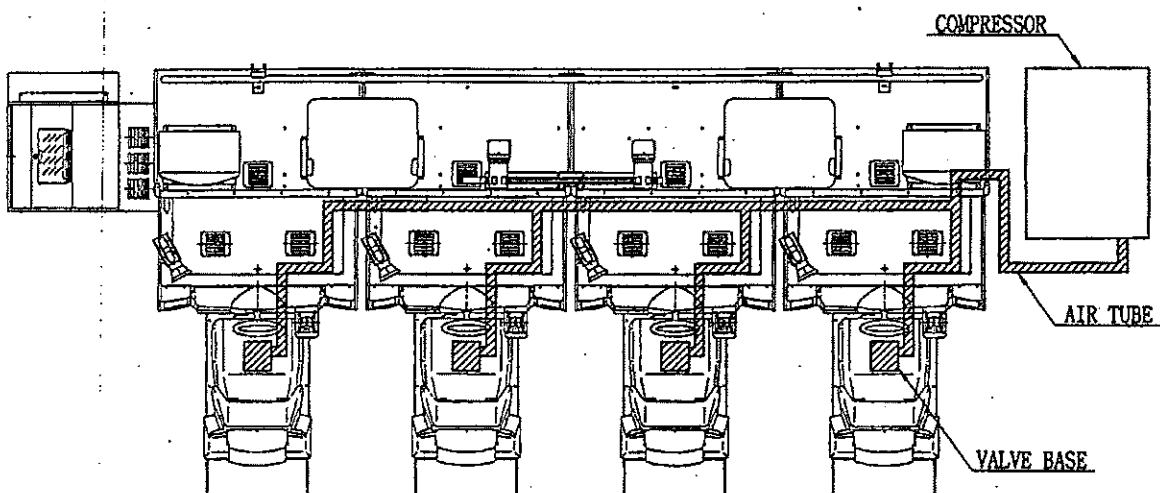

## 12-1 COMPOSITION OF AIR DRIVE SYSTEM

The Air Drive is comprised of the following equipment.

### ① COMPRESSOR

Being comprised of the AC Motor, Compressor, Air Tank, Cooler and Regulator, this is an integrated unit and has the following features:

#### (a) AUTO UNLOADER VALVE's FUNCTION

When the Compressor attains the maximum pressure, air compression stops. At the time the pressure decreases as a result of using the compressed air in the tank, air compression restarts.

#### (b) AUTO DRAIN FUNCTION

Automatically discharges the drain water in the tank when the filter is fully filled with drain water.

### ② VALVE

A diverter type (of AC 100 V) which utilizes solenoid force to operate the valve is employed.

### ③ CYLINDER

The air pressure CYLINDER transforms pneumatic energy into linear movement. In this game, two back to back type cylinders are used to drive each seat.

## 12-2 INSPECTION ITEMS OF AIR DRIVE SYSTEM

In order to maintain the performance of this game, carry out the following inspections and maintenance.

The Compressor's maintenance inspection items of this system are as follow. For the details of the inspection method, refer to the instruction manual which comes with the Compressor.

	CONTENTS	PERIOD	INSPECTION METHOD
AIR COMPRESSOR	Filter cleaning of the suction type purifier	Monthly	Refer to COMPRESSOR Manual
	Filter replacement	Every 6 months	
	Functioning of AUTO UNLOADER VALVE: Is the pressure normal?	Daily	
	Check the functioning of SAFETY VALVE.	Monthly	
MECHANISM PORTIONS	Greasing of Seat Frame Guide portion	Every 3 months	1 2 - 3
	Greasing the Rpd End portion.	Every 6 months	1 2 - 3

### WARNING!

#### WHEN REMOVING THE AIR TUBE:

Since this machine utilizes compressed air, removing the air tube for the purpose of inspections may cause the high pressure air to blow out. Therefore, before commencing work, be sure to turn the main power switch OFF first and extract the air from the tank until the pressure gauge indicates 0 kg/cm<sup>2</sup>.

To extract the air, turn the Regulator Knob (for pressure setting) fully in the direction the pressure gauge will indicate 0 kg/cm<sup>2</sup>.

### 12-3 GREASING

Apply greasing to the Mechanism Seat Frame Guide portion and Rod End every 3 and 6 months respectively.

- ① Remove Stopper (3 points), Seat Back Cover L, Seat Back Cover R, and Seat Back Cover sequentially in order (Fig. 12.3 a).
- ② Apply spray greasing to the Seat Frame Guide portion of the B part (refer to 12-3 b).
- ③ Apply grease in a manner to seal it in to the grease nipples of Rod End by using the grease gun.

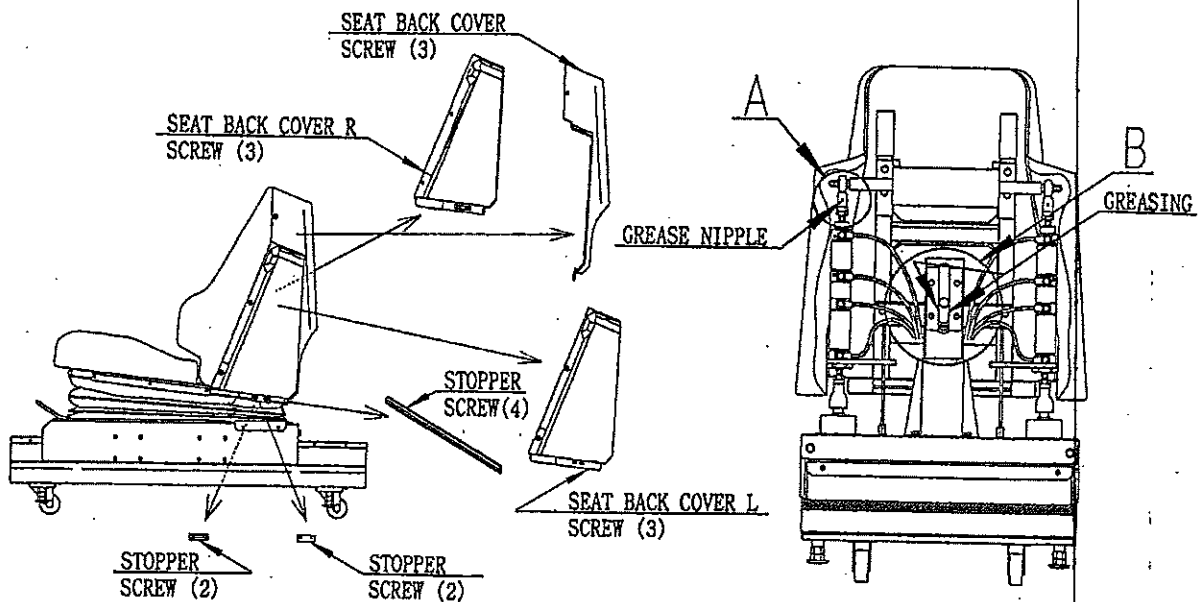

#### CAUTION:

Use the following for SPRAY GREASE and GREASE FOR GREASE GUN:

- NOK KLUBER L60 (SPRAY GREASE)
- GREASE MATE (SPRAY GREASE, PART No. 090-0060)
- GREASE FOR GREASE GUN (PART No. 090-0084)
- ALVANIA EP GREASES No. 2 (SHELL)
- DAPHNE EPONEX EP GREASES No. 2 (IDEMITSU)

## 12-4 ADJUSTING THE DRIVE SYSTEM

**CAUTION:** Setting the set pressure to a value other than that specified or making adjustment of the Speed Controller may cause the function or durability of each mechanism to be lowered.

The compressed air in the tank is regulated to a certain set pressure by means of a Compressor regulator and then the regulated air is supplied for each cylinder. Also, the air flow for each cylinder is adjusted to an adequate value by means of Air Cylinder and valve's Speed Controller. At the time of shipment, the regulator setting is made and the marking is applied to the Speed Controller after adjustments. Should any setting change be made by mistake, correct the setting to the one made at the time of shipment. When adjustments are required for replacing parts, etc., follow the procedure below:

- ① Remove Stopper (3 points), Seat Back Cover L, Seat Back Cover R, and Seat Back Cover sequentially in order (Fig. 12.3a).

- ② Loosen the Speed Controller's locknut from each part and make adjustments by loosening B portion's adjustment screw one and half turns from fully fastened condition and then fastening the locknut (Fig. 12.4 a Details of B Portion). For the adjustment of C portion, enter TEST mode from the status of POWER ON, choose DRIVE BD TEST → CYLINDER TEST, and cause CYLINDER to move with QUICK BREATH RIGHT (LEFT) OFF, and RIGHT (LEFT) LOWER ON, and make adjustments of the Adjustment Screw in a manner so that it takes approximately 4 to 5 seconds after the Cylinder starts moving and until its movement ceases, then fasten the locknut (refer to Section 10).

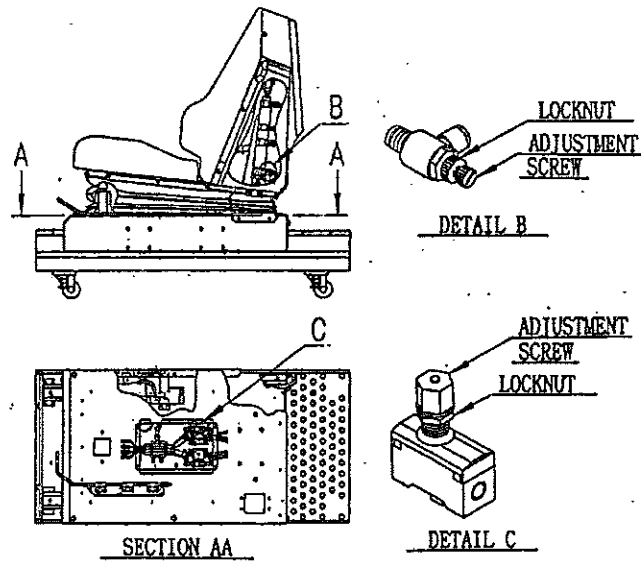

FIG. 12.4a

- ③ When adjusting the Regulator, pull up the adjustment knob and adjust the set pressure by turning knob as shown. After adjustments, pull down the knob and make sure that it does not turn (Fig. 12.4 b).

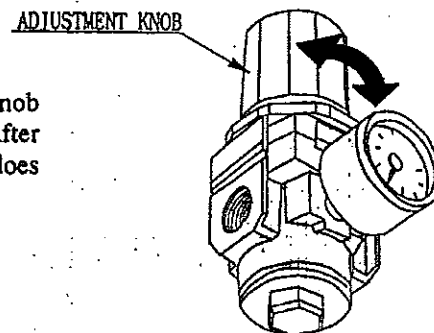

FIG. 12.4b



### 13. CONTROL PANEL(HANDLE MECHA)

In the TEST mode, if the steering wheel V. R. value variations are not within the allowable range, an adjustment of the V. R. installation position or replacement of the V. R. are needed. Also, apply grease to the steering wheel mechanism's shaft and sliding portions once every 3 months.

To perform the above work, take off the 2 truss screws and remove the Front Cabi's Service Door by using the master key. The Service Door has a fan attached to it. When removing the Service Door, pay careful attention so as to avoid causing damage to the Fan's wiring by catching it.

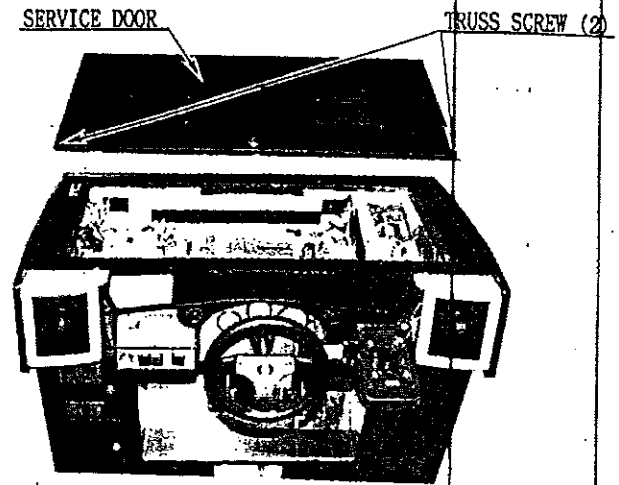

FIG. 13.1

#### 13-1 REPLACING AND ADJUSTING THE HANDLE'S (STEERING WHEEL'S) V. R.

The upper side V. R. of the HANDLE MECHA is for the GAME BD., and the lower side one, for the DRIVE BD.

Check the value of the V. R. for the DRIVE BD. The appropriate value of each V. R. is as follows:

When the steering wheel is turned to or positioned at:	Left	Centering position	Right
V. R. for the GAME BD. :	Under 2 DH	← 7DH~83H →	Over D3H
V. R. for the DRIVE BD. :	Under 2 DH	← 7DH~83H →	Over D3H

#### Method of V. R. replacement

To replace the V. R., after taking off the connector from the V. R. to be replaced, take out the 2 screws which secure the VR BRACKET, and remove the V. R. together with the bracket and gear. After the replacement, check the V. R. value variations in the test mode.

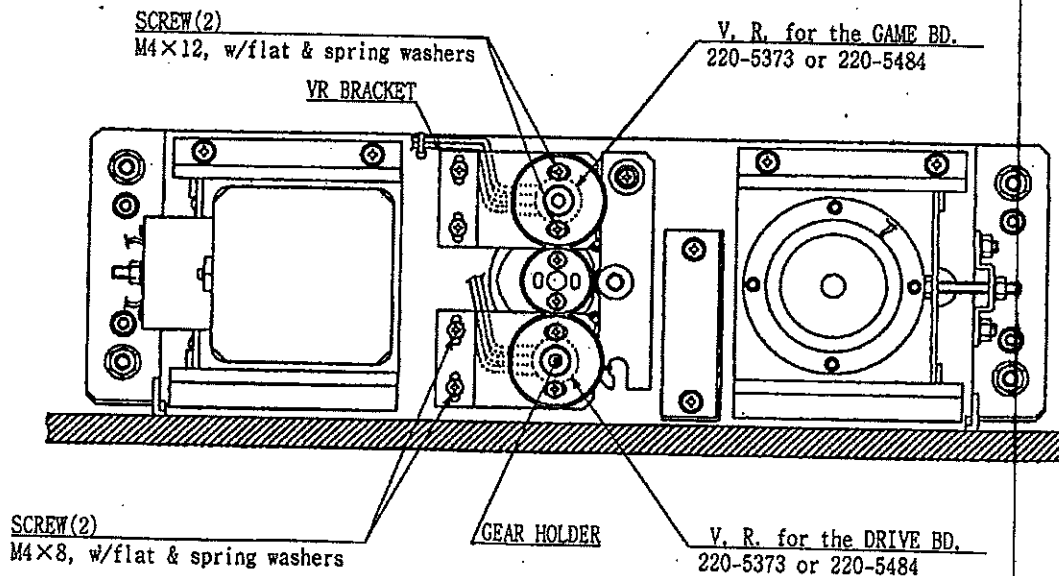

FIG. 13.2

### Method of V. R. adjustment

- ① Loosen the 2 screws which secure the V. R. BRACKET, move the V. R. BRACKET and detach the gears.
- ② Adjust the V. R. so that it is consistent with the value near the centering position.
- ③ Cause the gears to be engaged and secure the V. R. BRACKET. At this time, make sure that an appropriate backlash is obtained.
- ④ If the V. R. value is not appropriate when the steering wheel is at the centering position, loosen the 2 screws which secure the V. R. gear, turn the gear holder to make a fine adjustment so that the V. R. value is within the allowable range.
- ⑤ Check the V. R. value variations by turning the handle.

### 13-2 GREASING

Once every 3 months, grease the gears, bearings, springs, and cam & arm's sliding portions.

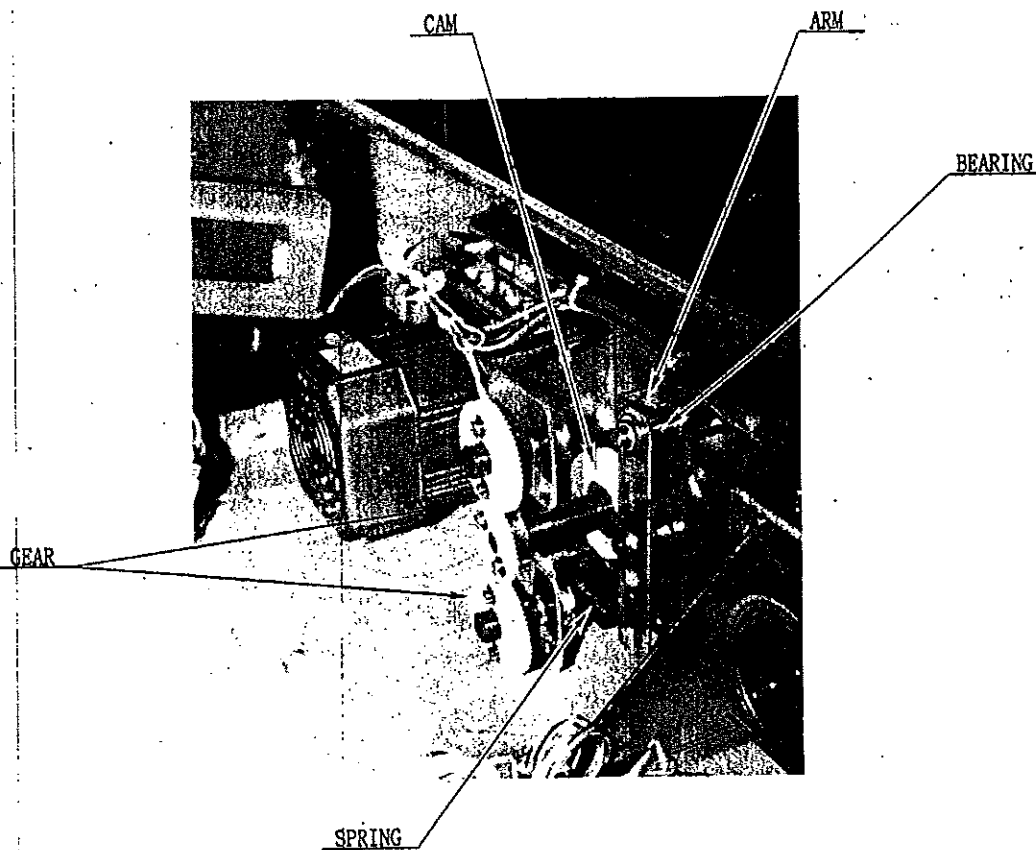

Fig. 13.3

## 14. 4 SPEED SHIFTER

In the test mode, if the shift lever input is found to be irregular, replace the switch or adjust the switch installation position. Also, grease the MECHA's shafts or sliding portions once every 3 months as a standard.

When performing the above work, remove the shift lever unit.

### 14-1 REMOVING THE SHIFTER

- ① Take off the 4 screws and remove SHIFT COVER A.
- ② Take out the 4 SPECIAL BOLTS and pull out the SHIFT LEVER UNIT upward by paying careful attention so as not to cause damage to the wiring.
- ③ Disconnect CONNECTOR 6P and remove the shift lever unit.

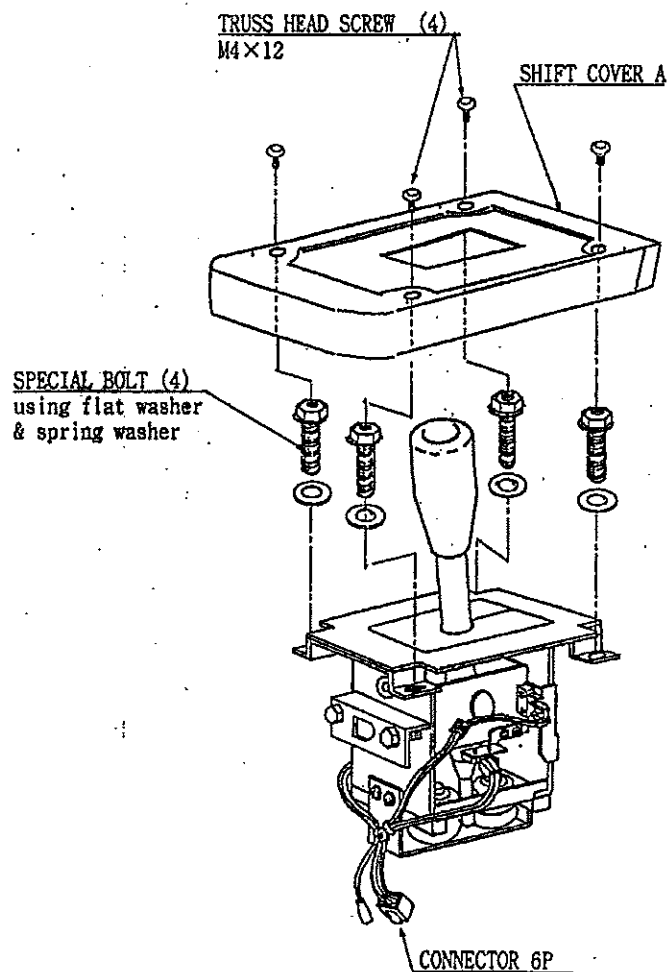

FIG. 14.1

## 14-2. REPLACEMENT AND ADJUSTMENT OF SWITCH

### Method of replacement

- ① Disconnect the wiring connector of the SW to be replaced.
- ② Take off the 2 screws which secure the BRACKET (SW BRACKET A & B) to which the SW is attached, and remove the SW together with the bracket. (FIG. 14.2)
- ③ Take off the 2 screws which secure the SW, and replace the SW.

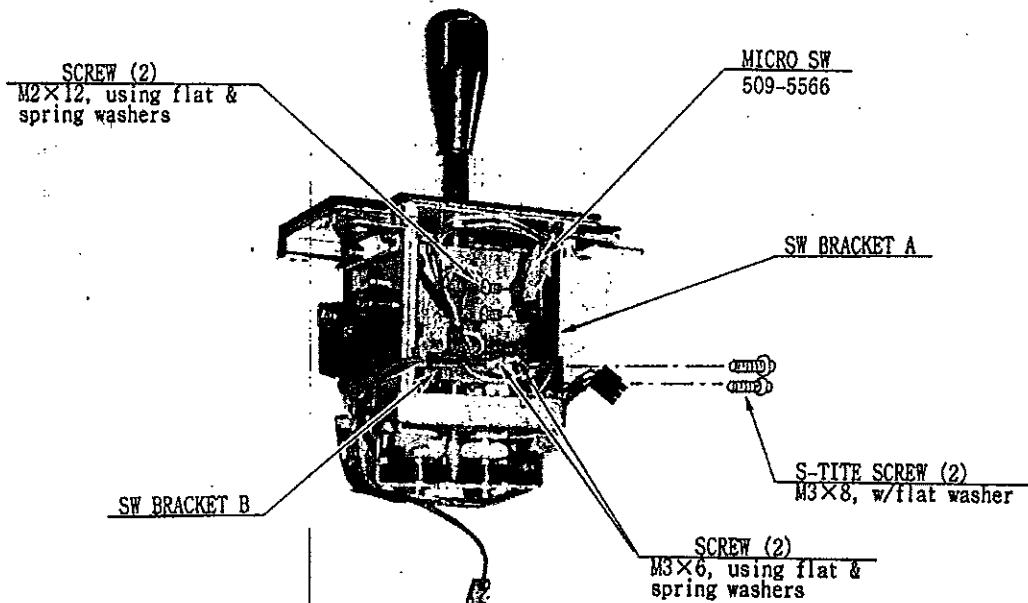

FIG. 14.2

- ④ To secure the replaced SW to the bracket, incline it as shown (FIG. 14.3). Securely fasten the screws by applying an anti-loosening agent to the screws.
- ⑤ Install the SW bracket with 2 screws. When installing SW BRACKET A, an adjustment in the following procedure is required.
- ⑥ After SW replacement, check the SW input in the test mode.

Secure the SW by inclining it clockwise.

Secure the SW by inclining it counterclockwise.

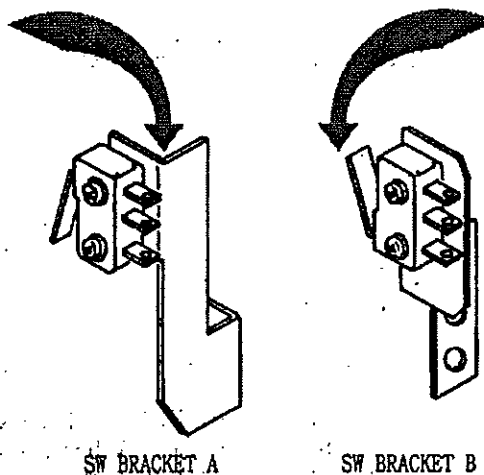

FIG. 14.3

### Adjustment to be made at the time of installing SW BRACKET A

- ① Shift to the first or second gear.
- ② At this time, secure SW bracket A with 2 screws in a manner so that the SW attached to SW Bracket A is caused to be ON.

### 14-3 GREASING

Apply grease to the following points once every 3 months as a standard.

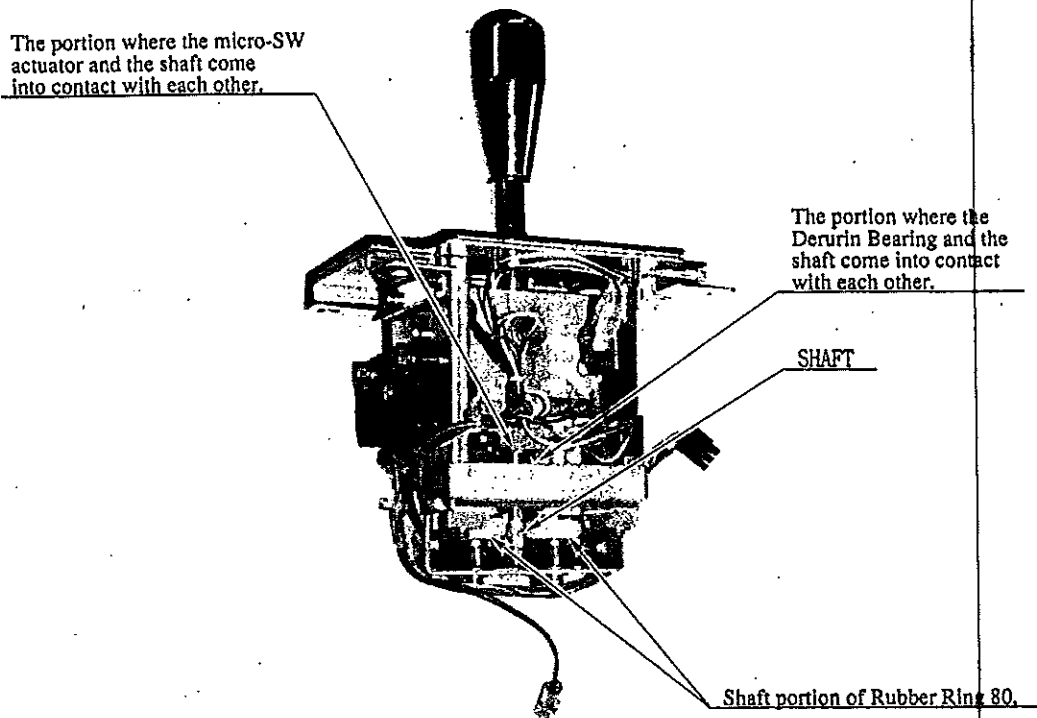

FIG. 14.4

### 15. ACCELERATOR & BRAKE

In the test mode, if the ACCEL. & BRAKE V. R. value is not within the allowable range, an adjustment of V. R. installation position, or a replacement of V. R. is needed. Also, grease the MECHA's shafts and sliding portions once every 3 months.

To perform the above work, take off the 4 tamperproof screws and pull the ACCEL. & BRAKE from the Front Cabi. The ACCEL. & BRAKE has wires connected to it. When pulling out, pay careful attention so as to avoid causing damaging the wiring.

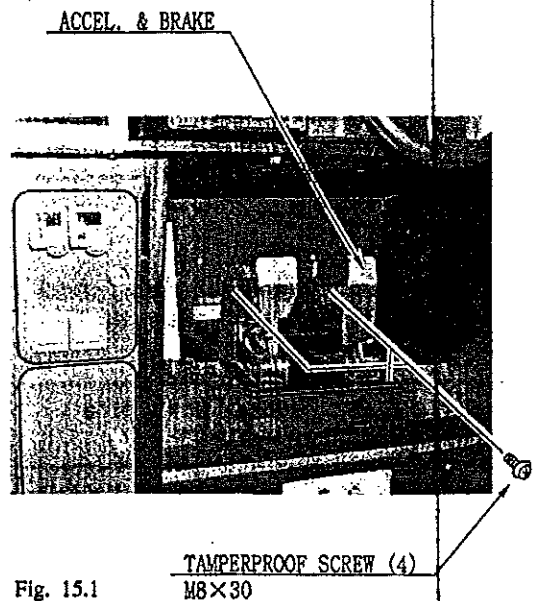

Fig. 15.1

## 15-1 ADJUSTMENT AND REPLACEMENT OF VOLUME

Each of ACCEL. & BRAKE has a V. R. respectively. Check each V. R. value on the Test mode screen. The appropriate value of each V. R. is as follows:

	When released:	↔	When stepped on:
ACCEL.:	Under 30H	↔	Over COH.
BRAKE :	Under 30H	↔	Over COH

### Method of V. R. replacement

To replace the V. R., after taking off the connector from the V. R. to be replaced, take out the 2 screws which secure the VR BRACKET, and remove the V. R. together with the bracket and gear. After the replacement, check the V. R. value variations in the test mode.

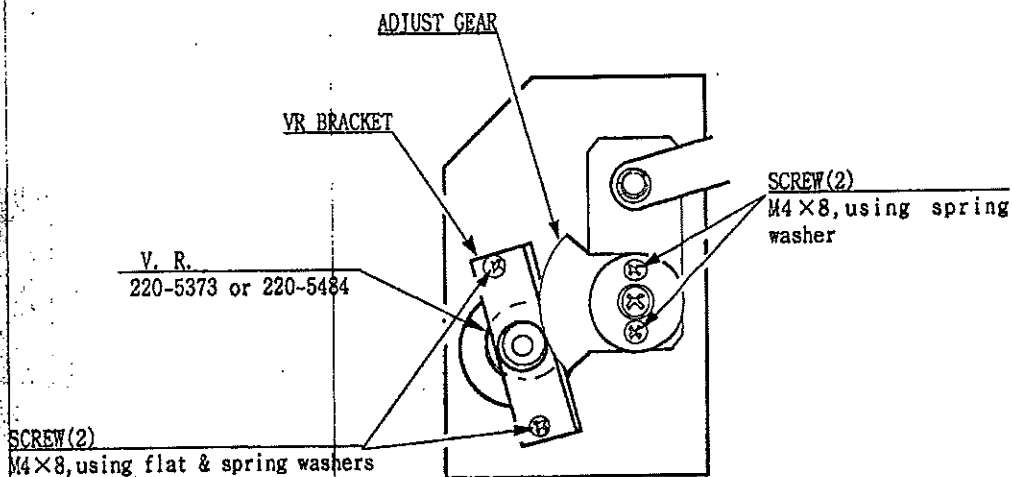

FIG. 15.2

### Method of V. R. adjustment

- ① Loosen the 2 screws which secure the V. R. BRACKET and move the V. R. BRACKET to disengage the gears.
- ② Cause the V. R. value to match with the value obtained when the pedal is released.
- ③ Cause the gears to be engaged and secure the V. R. BRACKET. At this time, be sure to obtain an appropriate backlash.
- ④ Step on the pedal and check the V. R. value variation.

## 15-2 GREASING

Grease the gears and bearings once every 3 months as a standard.

## 16. CCD CAMERA ADJUSTMENTS

At the time of shipment, the CCD Camera adjustments were made in a manner so that best images could be obtained, with the CCD camera (fixed to the Front Cabi ) facing fully in the direction of the player (refer to Section 6). For changing image angles or making focus adjustment, follow the procedure below:

- ① Have the images taken by the CCD Camera (to be adjusted) appear on the 25 inch monitor. There are two methods available.

- Use Test Mode (refer to Section 10).

Enter the Test Mode at the Seat where the the CCD Camera to be tested is attached.

- 1) Choose CYLINDER TEST in the DRIVE BD TEST.
- 2) Bring the arrow to the CCD PRIORITY item.

- Use the CONTROL TOWER (refer to Section 11).

This method is possible when all of the Seats are not in game play.

- 1) Insert the key into the MAIN SW. of the Control Tower's Service Panel to turn it ON.
- 2) Switch over the FUNCTION SW. to VIDEO.
- 3) Press the Entry SW. of the Seat where the CCD Camera to be tested is attached.

- ② Take off the screw to remove Cover Front.

- ③ Turn the CCD Camera's Lens Ring to allow aperture and focus to be adjusted (Fig. 16.1)

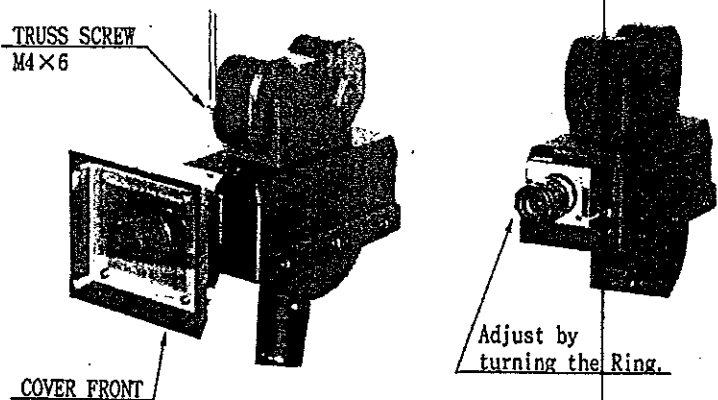

Fig. 16.1

- ④ When making image angle changes, remove all of the Cover parts (Fig. 16.2).

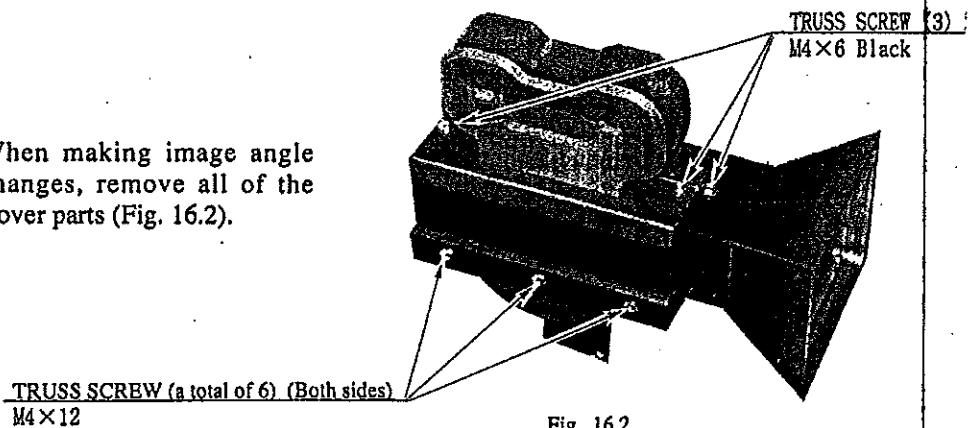

Fig. 16.2

- ⑤ For angle changes in vertical directions, loosen the 4 screws on each side and adjust the direction of the camera (Fig. 16.3). For changing the angle in horizontal directions, normally, loosen the 2 screws of the support and adjust the direction of the camera. When further changing the angle in horizontal directions, adjust the direction of the camera by loosening the 2 screws shown in Fig. 16.3.
- ⑥ After adjustments are finished, retighten the loosened screws and install Cover parts.
- ⑦ Clear the status mentioned in Procedure ① in which images are shown by priority on the 25 inch monitor. When the TEST MODE is used, finish the test mode procedure. When the Control Tower is used, turn the Service Panel's Main SW off.

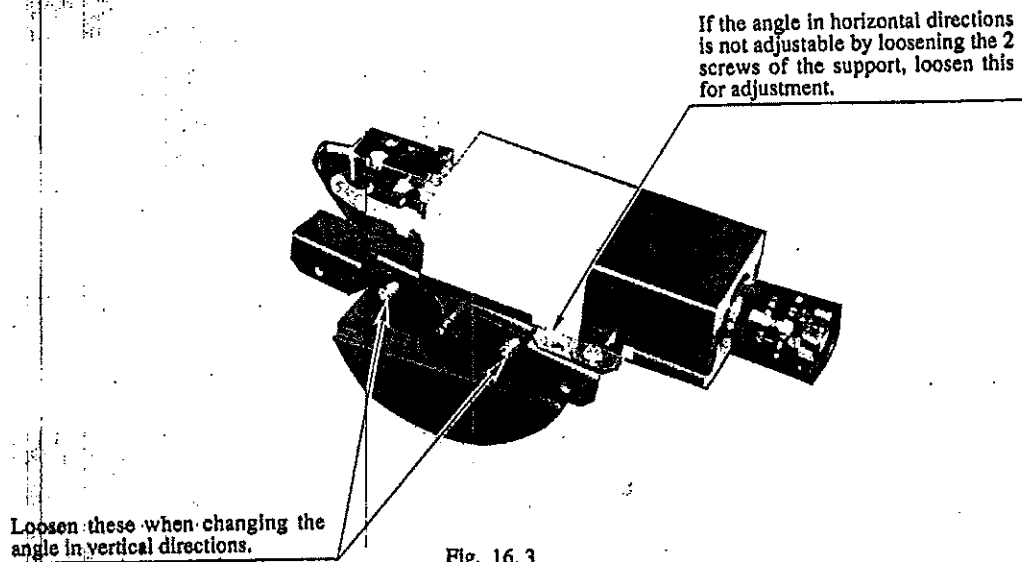

Fig. 16.3



## 17. CIRCUIT PROTECTOR AND FUSE

In this machine, each seat has a Circuit Protector and Fuse, and the Control Tower has one Fuse.

### CIRCUIT PROTECTOR

The Front Cabi's AC Unit has a Circuit Protector. When the power is turned ON, should there be an irregularity such that the image of a Seat is not projected on the screen, etc., be sure to check the Circuit Protector and the Power SW of that particular Seat.

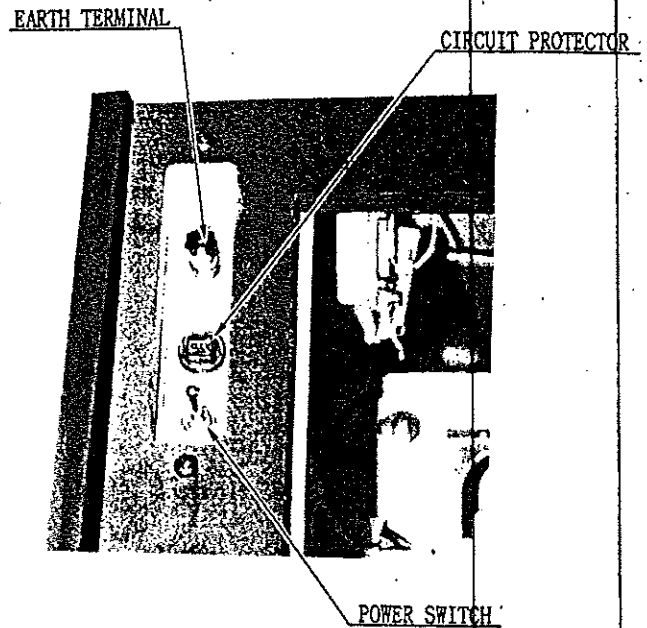

Fig. 17.1 CIRCUIT PROTECTOR

### FUSE

Take off the Panel in the front of the Control Tower, and the Power Supply Unit appears at the lower portion. The Power Supply Unit has a Fuse for the Control Tower Power supply and Spotlight. When the power is turned ON, should there be an irregularity such that the Spotlight does not light up or no sound is emitted from the on-PTV speaker, be sure to check the Fuse.

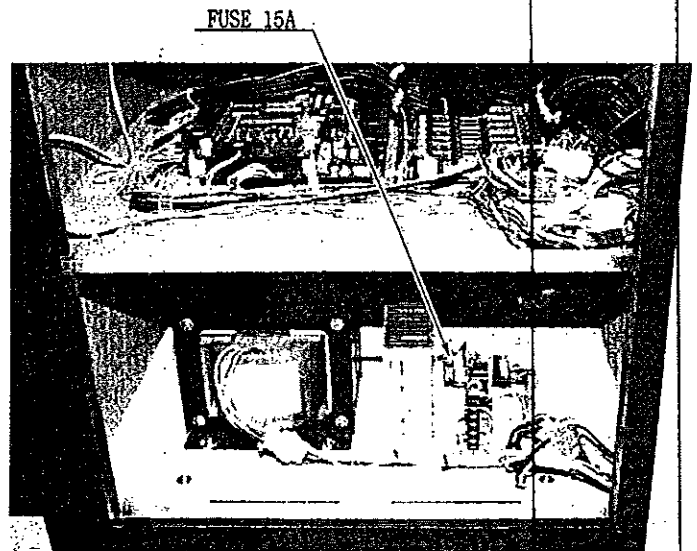

Fig. 17.2

Should there be an irregularity such that the power cannot be turned ON and if the Circuit Protector is not activated or the irregularity still continues even if it is depressed, it is considered that the Fuse of that particular Seat's Power Supply Unit is blown. Check the Fuse by taking out the Power Supply Unit in accordance with the following procedure:

- ① Turn the Power Supply SW of that particular Seat's AC Unit OFF.

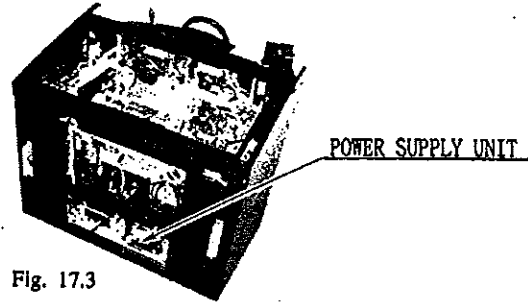

Fig. 17.3

- ② By referring to Section 6, remove the Front Cabi from the PTV (Fig. 17.3).

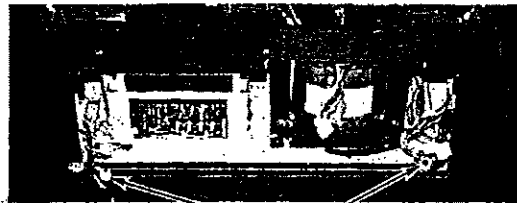

Fig. 17.4

- ③ Disconnect all of the Power Supply Unit related wiring Connectors (Fig. 17.4).

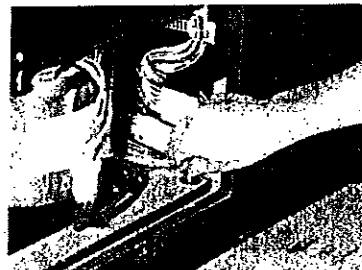

Fig. 17.5

- ④ Take off the 2 Wing Bolts which secure the Power Supply Unit Base Board (Fig. 17.5).

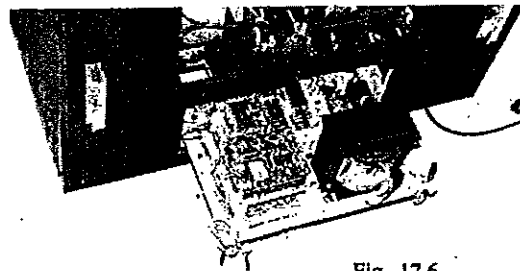

Fig. 17.6

- ⑤ Take out the Power Supply Unit from the Front Cabi. Since the Power Supply Unit on which the Transformer is mounted, is a heavy item, be very careful when performing the work (Fig. 17.6).

- ⑥ The PC BOARD of the Power Supply Unit has a fuse shown (Fig. 17.7).

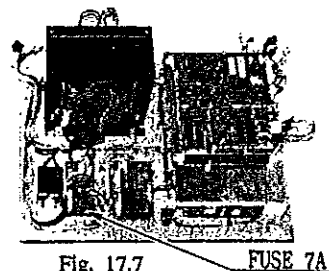

Fig. 17.7

## 18. REPLACING THE FLUORESCENT LAMP, AND LAMPS

In a manner as shown below, remove the parts and relace the fluorescent lamp and lamps.

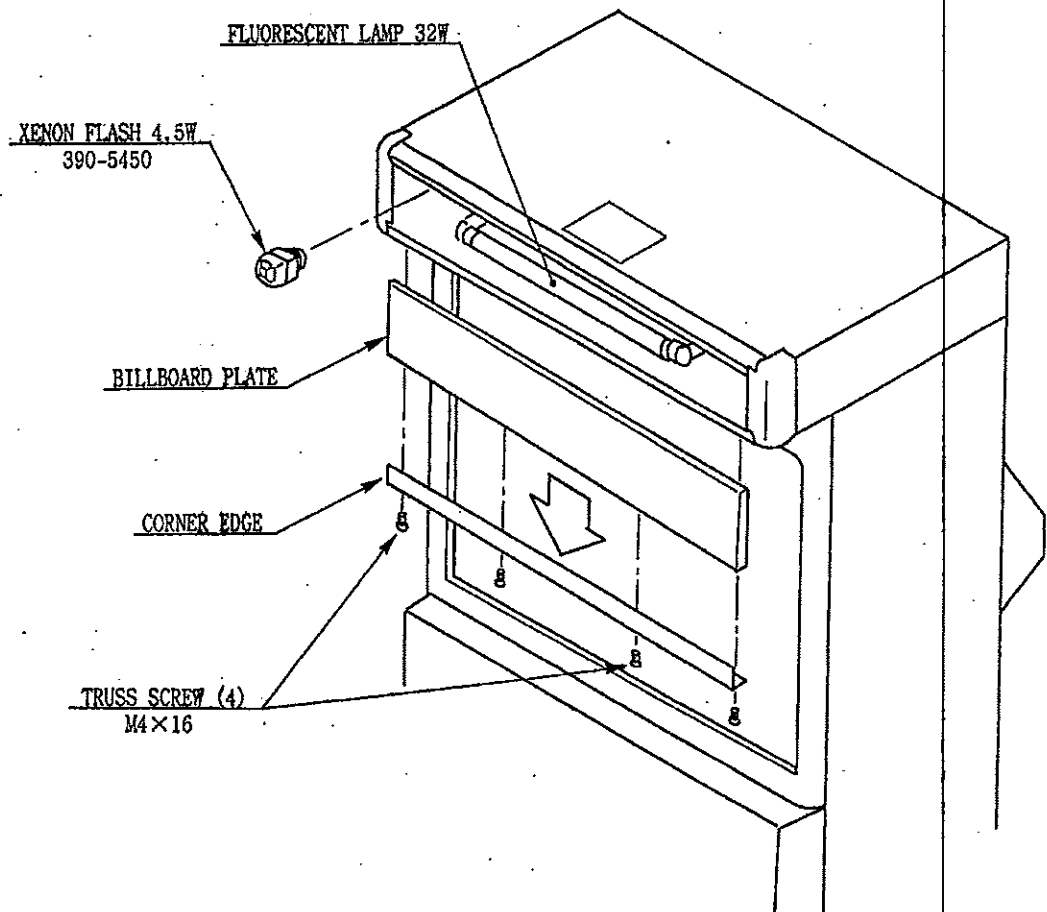

Fig. 18

## 19. COIN SELECTOR

### HANDLING THE COIN JAM

Even when the **REJECT** button is pressed, if the coin is not rejected, open the coin chute door and open the selector gate. After removing the jammed coin, put a normal coin in and check to see that the selector correctly functions.

### CLEANING THE COIN SELECTOR

The coin selector should be cleaned once every 3 months. When cleaning, follow the procedure below:

- ① Turn the power for the machine OFF. Open the coin chute door.
- ② Open the gate and dust off by using a soft brush (made of wool, etc.).
- ③ Remove stain by wiping with a soft cloth which contains water or chemical detergent.
- ④ Remove the **CRADLE**. When removing the retaining ring (E ring), be very careful so as not to bend the shaft.
- ⑤ Remove stain from the shaft and pillow portions by wiping off with a soft cloth, etc.
- ⑥ After wiping off as per 5 above, further apply a dry cloth, etc. to cause the coin selector to dry completely.

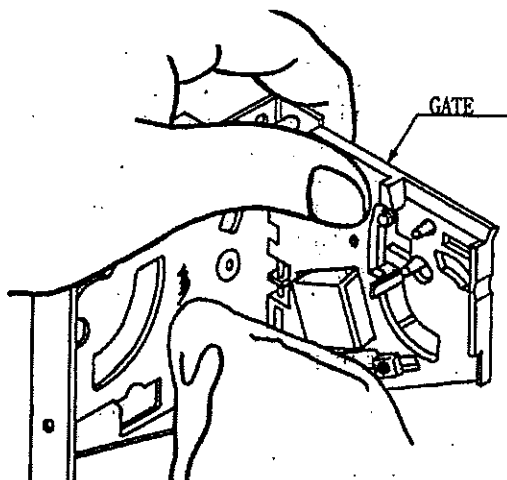

#### NOTE:

Absolutely do not apply machine oil, etc. to the coin selector.

After cleaning the coin selector, insert a regular coin in the normal working status and ascertain that the selector correctly functions.

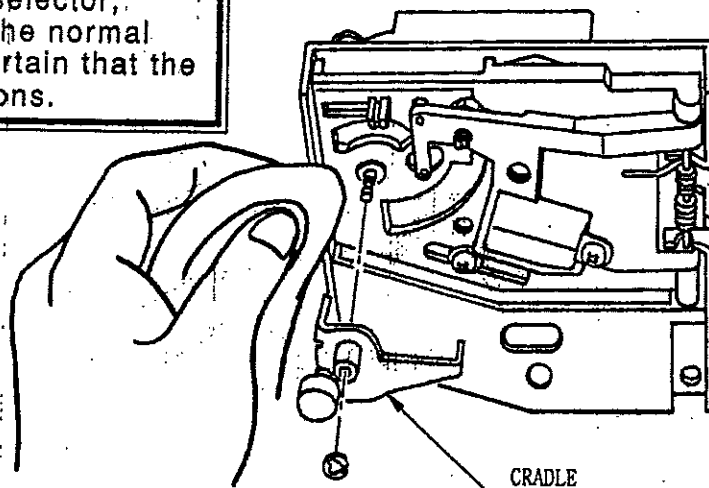

## 20. PROJECTOR

### CAUTION!

- Since the Projector screen is susceptible to damage, pay careful attention to its handling. When cleaning, refrain from using water or volatile chemicals.
- Since the Projector has been adjusted at the time of shipment, Avoid making further adjustments without good reason.

Fine adjustments are stored in the Projector. Pressing the Fine Adjustment SW (Convergence Adjustment) results in entering the Fine Adjustment mode, and this may cause the stored fine adjustment to be changed. During work other than for adjustment, should you touch the Fine Adjustment SW by mistake, immediately turn the power off by using the main SW and then turn it back on again. If any distortion or color deviation is found in the test mode and adjustments are needed, use the specified Adjustment knob, or perform the adjustment by remote control. Note that there are two PROJECTOR makes (HITACHI & MITSUBISHI) and the adjustment method is different between the two. When checking the Adjustment Control knob, remove the PTV's Service Door. For the HITACHI Projector, open the cover in front of the control panel. For the MITSUBISHI Projector, remove the cover.

### 20-1 CLEANING THE SCREEN

When the screen surface becomes dirty with dust, etc., clean it by using a soft cloth such as gauze. When water, and volatile chemicals such as benzine, thinner, etc., spill on the screen surface, it may be subject to damage, therefore, do not use them. Also, since the surfaces are susceptible to damage, refrain from rubbing them with a hard material or using a duster.

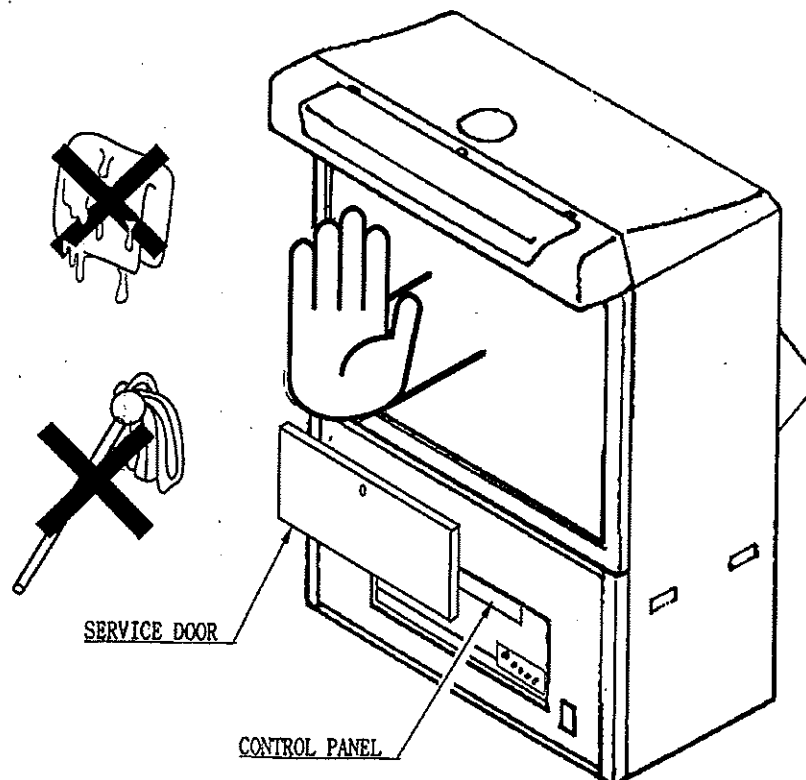

## 20-3 MITSUBISHI PROJECTOR

### □ MITSUBISHI PROJECTOR CONTROL PANEL

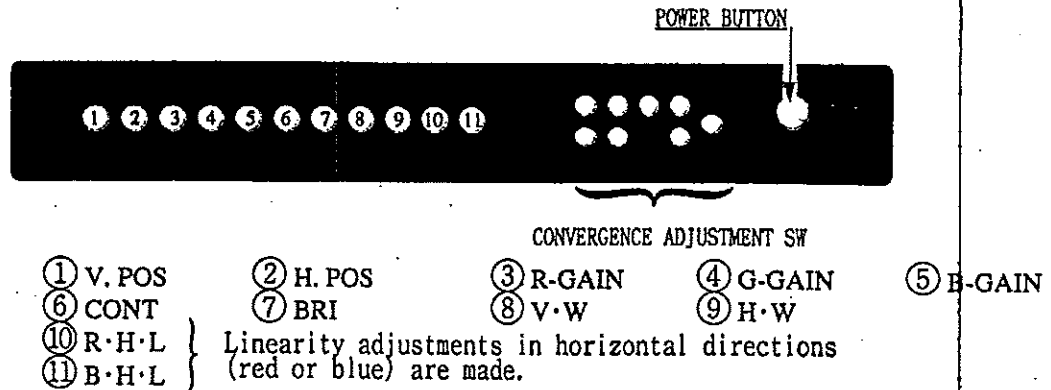

### STATIC CONVERGENCE ADJUSTMENT

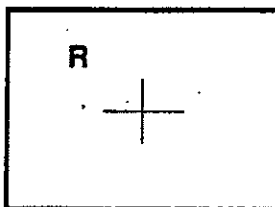
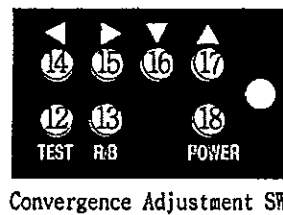

- |         |                      |
|---------|----------------------|
| ⑫ TEST  | Test mode on/off key |
| ⑬ R/B   | R/B shift key        |
| ⑭ ◀     | Left shift key       |
| ⑮ ▶     | Right shift key      |
| ⑯ ▼     | Lower shift key      |
| ⑰ ▲     | Upper shift key      |
| ⑱ POWER | Power button         |

- ① For the Convergence adjustment mode, press the test mode on/off key ⑫.
- ② Ascertain that "R" is displayed on the screen.
- ③ Make adjustment so as to cause the red cross pattern to match with the green cross pattern by using Left Shift key ⑭, Right shift key ⑮, Lower shift key ⑯ and Upper shift key ⑰.
- ④ By using R/B shift key ⑬, cause the red adjustment "R" to shift to blue adjustment "B" and make sure that "B" is displayed on the screen.
- ⑤ In the same manner as in ③ above, cause the blue cross pattern to match with the green cross pattern.
- ⑥ After making adjustment, press the test mode on/off key ⑫ to cancel the Convergence adjustment mode.

## STATIC CONVERGENCE ADJUSTMENT WITH REMOTE CONTROL

### CAUTION

- Although the remote control buttons other than the following do not function during convergence adjustment even if they are pressed, do not press them during the adjustment work.
- When operating the remote control, direct it on to the PTV screen.

**BEFORE USING THE REMOTE CONTROL:** First make sure that the main SW on the Projector's control panel is ON (the LED adjacent to the main SW is lit).

- ① For the Convergence Adjustment mode, press the test button (FIG. 1 · 5 below). Ascertain that "R" is displayed on the screen.
- ② Make adjustment so as to cause the red cross pattern to match with the green cross pattern. When the red cross matches the green cross, the green cross turns yellow or white (FIG. 2 · 3 · 4 below).  
Use remote control buttons shown below to move the red cross as follows:  
Button ⑤ ..... to the left.  
          ⑦ ..... to the right.  
          ② ..... Upward.  
          ⑩ ..... Downward.
- ③ Use Remote Control button ⑥ to shift "R" to "B." Make sure that "B" is displayed on the screen. Each time Button ⑥ is pressed, red and blue adjustments are shifted.
- ④ In the same manner as in ② above, cause the blue cross to match with the green cross. When the blue cross matches with the green cross, the green cross turns white.
- ⑤ After adjustment is made, press the test button (FIG. 1 · 5 below) to cancel the Convergence Adjustment mode.

**Note:** When 2 minutes or more elapses in the Convergence mode screen without taking any action, the on-screen adjustment mode will disappear.

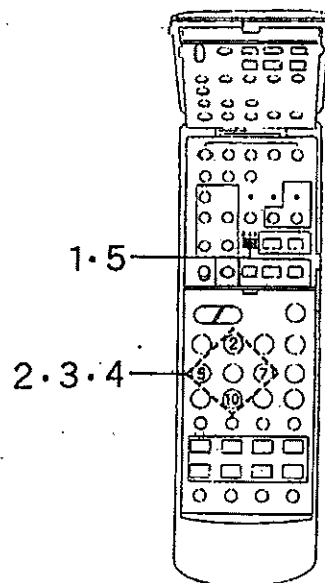
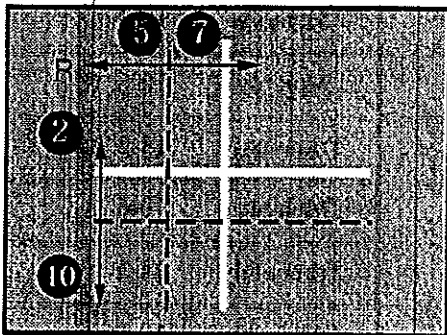

## 21. PERIODIC INSPECTION TABLE

In order to maintain the performance of this game, carry out the following inspections and maintenance.

	CONTENTS	PERIOD	INSPECTION METHOD
HAZARD PREVENTING FUNCTION	Check the functioning	Daily	8, 10
PERIODIC CHECK	SELF TEST, MEMORY CHECK	Monthly	10-10, 10-11
	Check each setting	Monthly	10-4, 10-5
AIR COMPRESSOR	Filter cleaning of the suction type purifier	Monthly	Refer to COMPRESSOR Manual
	Filter replacement	Every 6 months	
	Functioning of AUTO UNLOADER VALVE: Is the pressure normal?	Daily	
	Is the drain water in the tank discharged?	Daily	
	Check the functioning of SAFETY VALVE.	Monthly	
MECHANISM PORTIONS	Seat Frame Guide Portion	Trimonthly	12-3
	Rod End Portion	Every 6 months	12-3
	Check the functioning of cylinder.	Monthly	10-8, 12-4
SWITCH	Check the status.	Monthly	10-6
LAMP	Check the status.	Monthly	10-7
CONTROL PANEL ACCEL. & BRAKE	Check the volume value	Monthly	10-6, 10-8
	Greasing	Trimonthly	13-2, 15-2
4 SPEED SHIFTER	Checking SWes.	Monthly	10-6
	Greasing	Trimonthly	14-3
COIN SELECTOR	Cleaning	Trimonthly	19
SCREEN	Cleaning	Weekly	20



## 22. TROUBLESHOOTING

When the plugs and wire connectors are disconnected, this situation may be mistaken for malfunctioning. For troubleshooting, first check the connecting of plugs and connectors.

PROBLEMS	CAUSE	COUNTERMEASURES
PTV screen is blackened and no sound is emitted.	The seat's power SW is OFF. Connections within the base is defective.	<ol style="list-style-type: none"> <li>① Check to see if the seat's power supply is ON.</li> <li>② Make sure of correct connection between the Control Tower and each Seat's Power Code.</li> <li>③ Check the Circuit Protector beside the Power Supply SW of the corresponding Seat (refer to Section 17).</li> <li>④ Check the Fuse of the corresponding Seat's Power Supply Unit. If the fuse is blown, replace it (refer to Section 17).</li> </ol>
PTV screen is all blue.	Irregular communications in between each seat.	<ol style="list-style-type: none"> <li>① Check the Communication Cable connection between the corresponding Seat's Game BD and I/O BD.</li> <li>② Turn the Power SW back on again.</li> </ol>
PTV screen remains in the network check mode.	Irregular communications in between each seat.  Fiber cable damage.	<ol style="list-style-type: none"> <li>① Check the Fiber Cable connections between each seat.</li> <li>② Check to see if the Fiber Cable is damaged. Does the connector fiber (opposite TX as shown) emit light? If not, replace the optical fiber.</li> <li>③ Replace the Communication BD.</li> </ol>
The color of image on PTV screen is incorrect.	Connector connections are defective.  Image adjustment is incorrect.	<ol style="list-style-type: none"> <li>① Check the connection for the RGB and SYNC Connectors of the BASE's front and back connector panels.</li> <li>② If the BRIGHT adjustment is made to the full, adjust by Remote Control.</li> </ol>
The image on PTV screen has color deviation.	Affected by the magnetic field of installation location.	Make CONVERGENCE adjustment. (Refer to section 20.)
PTV BILLBOARD Fluorescent lamp does not light up.	The seat's power SW is OFF.  Fluorescent lamp needs replacement.	<ol style="list-style-type: none"> <li>① Check to see if the seat's power SW is ON.</li> <li>② Replace fluorescent lamp (Refer to section 18.)</li> </ol>

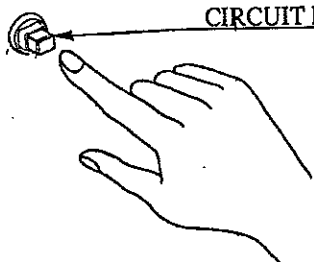

**CIRCUIT PROTECTOR**

Functions due to the activation of bimetal. To restore the function, wait for approximately one minute or longer until the bimetal cools off.

PROBLEMS	CAUSE	COUNTERMEASURES
PTV BILLBOARD flash lamp does not light in course selection/output test.	Flash lamp life expired. Defective connections.	① Check to see if the flash lamp is loosened. ② Replace the flash lamp (refer to Section 18).
The control panel's VR button does not light up.	Lamp's life expired.	Replace the button.
The control panel's start switch does not light up.	Lamp's life expired.	Replace the switch. The start switch lights up only when Free Play is set.
During game, operation of Steering Wheel is not satisfactory.	Incorrect V.R. setting. Malfunction of V.R.	① V.R. adjustment (refer to Section 13). ② V.R. replacement (refer to Section 13).
During game, pedal operation is not satisfactory.	Incorrect V.R. setting. Malfunction of V.R.	① V.R. adjustment (refer to Section 15). ② V.R. replacement (refer to Section 15).
Steering Wheel reaction strength is insufficient.	Incorrect V.R. setting. Malfunction of V.R.	① V.R. adjustment (refer to Section 13). ② V.R. replacement (refer to Section 13). ③ If no irregularity is found in V.R., the problem may have been caused by secular change. Change DRIVE BD DIP SW setting (refer to Section 10, 23). ④ Check to see if grease attaches to the belt.
No sound is emitted from the Control Panel's Speaker.	V.R. adjustment error. Board malfunctioning.	① Adjust the Volume Control inside the Coin Chute Door. ② Perform sound test (refer to Section 10).
No sound is emitted from the Speaker.	V.R. adjustment error. Blowing off of fuse.	① Check the Power SW and Knobs of the Control Tower's Amplifier (see Section 11). ② Replace the Fuse in the Control Tower (see Section 17).
The Spotlight does not light up.	Lamp needs replacement. Fuse needs replacement.	① Replace the lamp. ② Replace the Fuse in the Control Tower (see Section 17).

## 23. GAME BOARD

When replacing the IC BOARD (Game BD, Drive BD, etc.) or changing DIP SW settings, remove the Front Cabi's Maintenance Door.

There are 2 DIP SWes on the Drive BD. By using No. 1~3 of DIP SW 2 (one of the 2 DIP SWes), set the handle reaction strength.

### CAUTION!

- Make sure that, where NOT USED is specified, that particular DIP SW is always set to OFF.
- When changing DIP SW setting, ensure that the power is OFF.

### SETTING CHANGE PROCEDURE:

- ① Turn the power SW of the Front Cabi of the Seat (for which setting changes are intended) OFF.
- ② Take off the 2 screws and unlock to open the Front Cabi's Maintenance Door which has wiring connections for the fan. To remove the Service Door, disconnect the wiring connector for the fan.
- ③ By taking off the Maintenance Door, the Drive BD can be viewed. By referring to Section 10, DIP SW 2 settings can be changed.

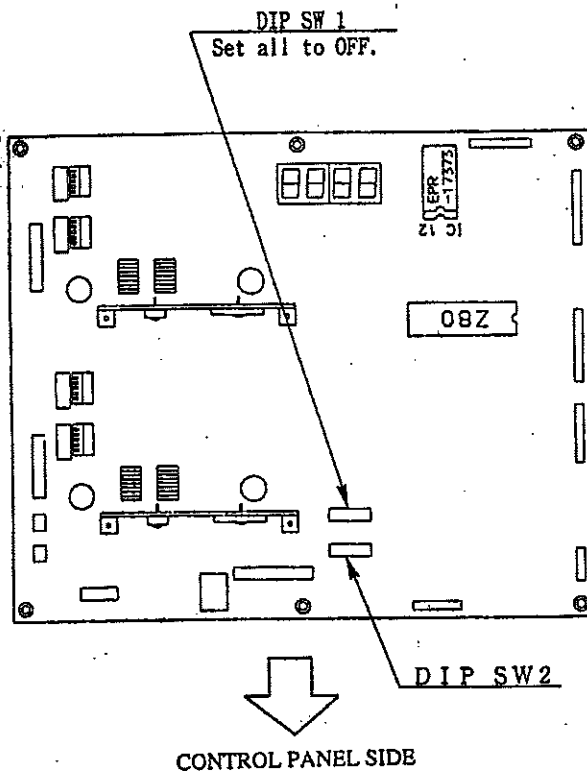

Fig. 23.1

### 23-1 TAKING OUT THE GAME BOARD

- ① Turn the Main SW of Front Cabi OFF.
- ② Take off the 2 screws and unlock to open the Front Cabi's Maintenance Door. Disconnect wiring connector for the fan to remove the Maintenance Door.

- ③ Disconnect all of the shield case related wiring connectors (Fig. 23.2).

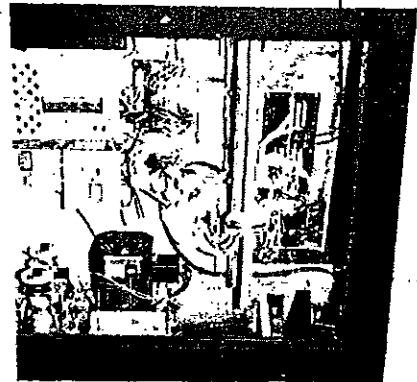

Fig. 23.2

- ④ The Shield Case is secured to the wooden Base. Take off the 2 screws which secure the Base to the Front Cabi (Fig. 23.3).

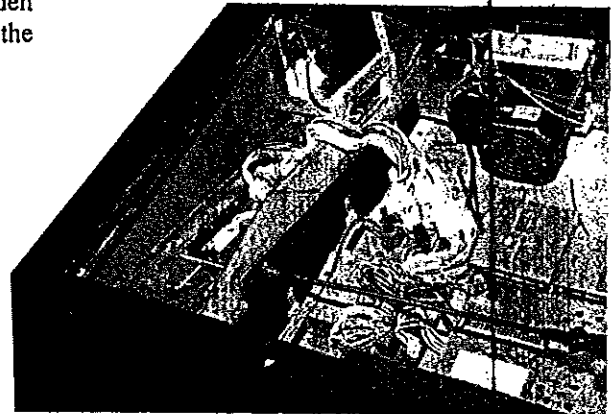

Fig. 23.3

- ⑤ By holding the catch, pull out the Shield Case together with the Base (Fig. 23.4).

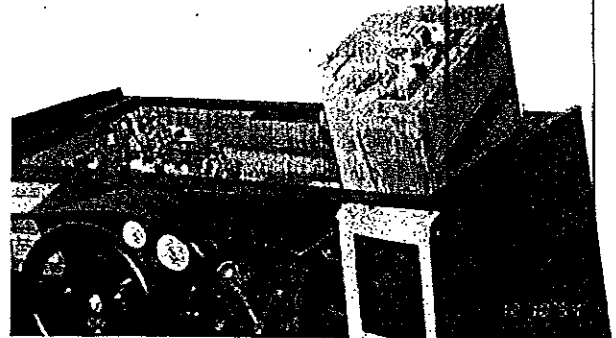

Fig. 23.4

- ⑥ Take off the 3 screws to remove Case Lid. The Game BD and I/O BD are contained in the Shield Case (Fig. 23.5).

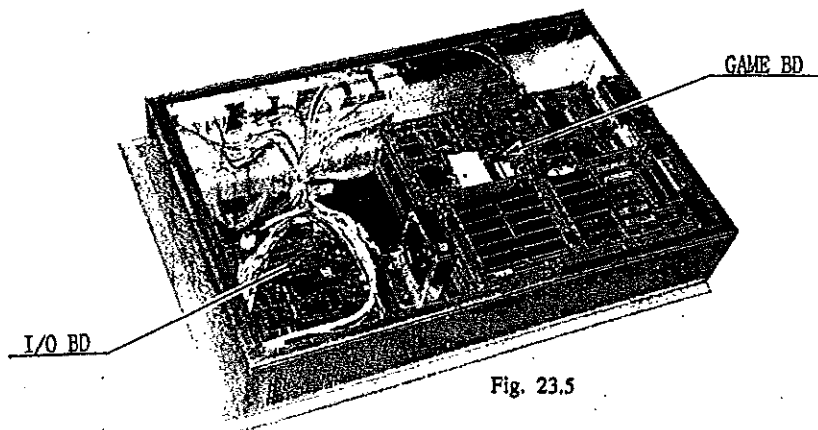
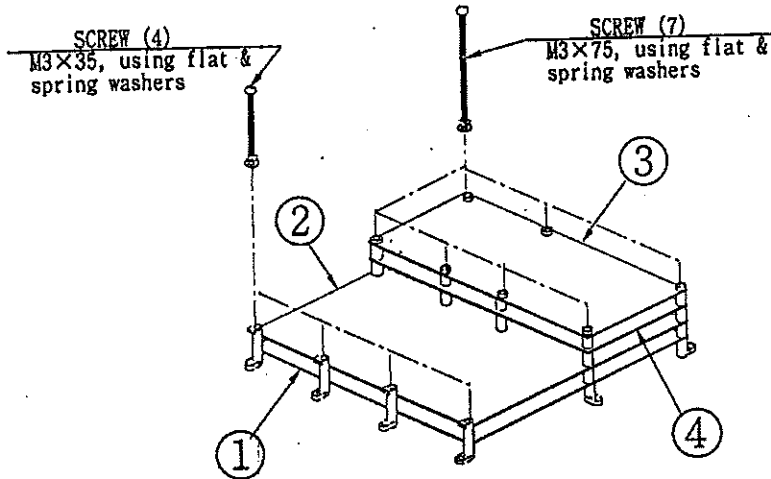

Fig. 23.5

### 23-2 COMPOSITION OF GAME BOARD

GAME BD DAYTONA USA SP (833-11338)



No.	PART No.	DESCRIPTION
1	837-10072-92	CGT VIDEO BD COM
2	837-10071-91	CGT CPU BD COM
	837-10071-91-01 837-10071-91-02	
3	834-11339	ROM BD DAYTONA USA SP
4	837-10537	COMM BD DAYTONA TWIN

### 23-3 INPUT/OUTPUT RELATIONS

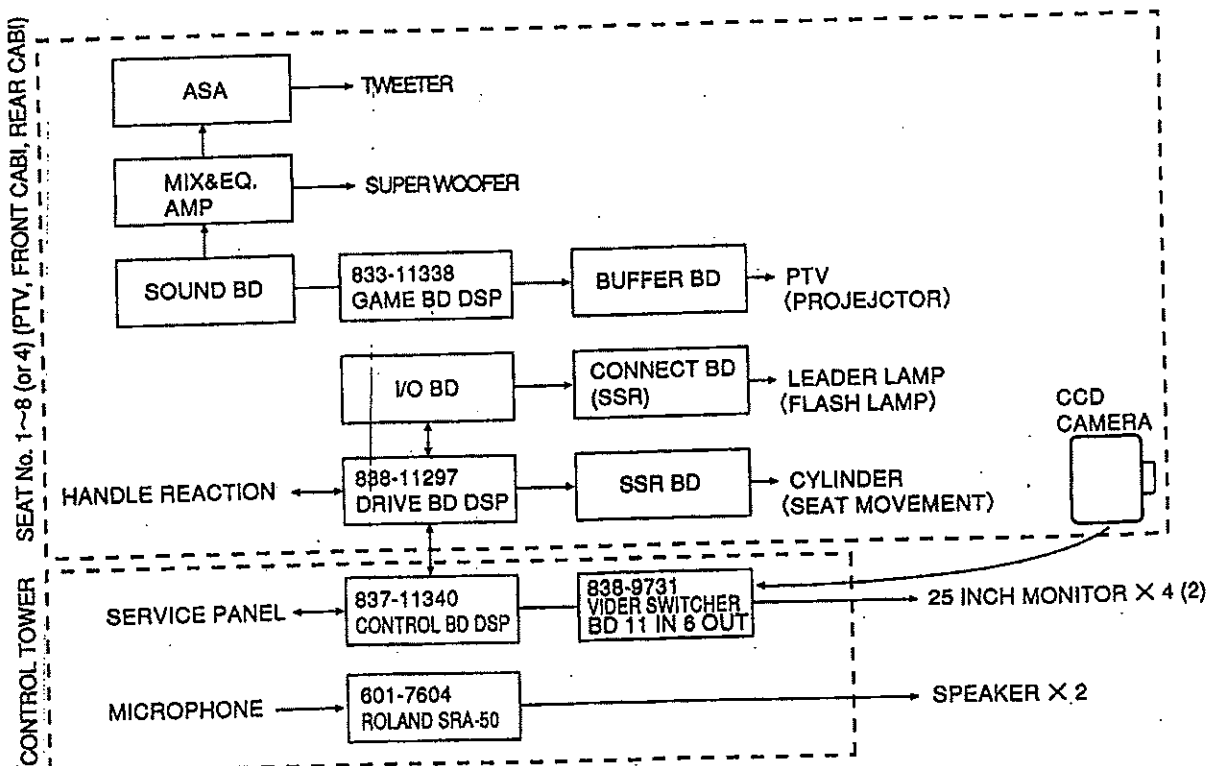

## 24. DESIGN RELATED PARTS

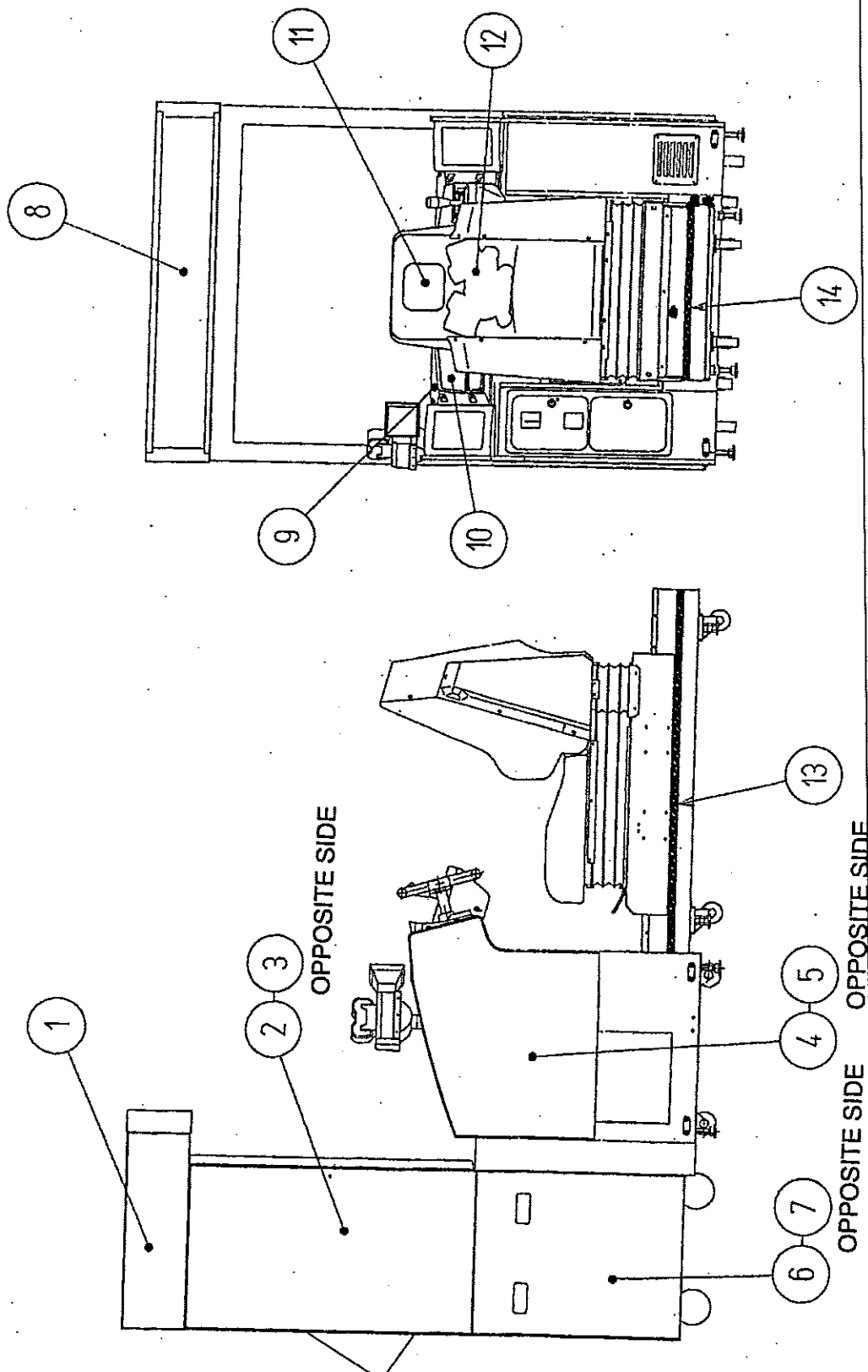

	PART No.	DESCRIPTION
1	DSP-0006	STICKER UPPER TV
2	DSP-0007	STICKER TV SIDE L
3	DSP-0008	STICKER TV SIDE R
4	DSP-0009	STICKER F CABI L
5	DSP-0010	STICKER F CABI R
6	421-8496	STICKER SIDE TV LOWER L
7	421-8497	STICKER SIDE TV LOWER R
8	423-0226-01	BILLBOARD PLATE RED
	" -02	" BLUE
	" -03	" YELLOW
	" -04	" GREEN
	" -05	" BLACK
	" -06	" PINK
	" -07	" SKY BLUE
	" -08	" ORANGE
9	422-0503-01	PLAY INSTR SH DSP ENG
10	422-0479-01	PLAY INSTR V.R BUTTON ENG
11	421-8546	STICKER CAR NO.1
	421-8547	STICKER CAR NO.2
	421-8542	STICKER CAR NO.TWINNO.3~NO.8)
12	DSP-2018	STICKER SEAT BACK COVER
13	DSP-2016-01	STICKER LINE L RED
	" -02	" BLUE
	" -03	" YELLOW
	" -04	" GREEN
	" -05	" BLACK
	" -06	" PINK
	" -07	" SKY BLUE
	" -08	" ORANGE
14	DSP-2017-01	STICKER LINE S RED
	" -02	" BLUE
	" -03	" YELLOW
	" -04	" GREEN
	" -05	" BLACK
	" -06	" PINK
	" -07	" SKY BLUE
	" -08	" ORANGE

# 25. PARTS LIST

## ① TOP ASSY DAYTONA USA SPCL 8P

(D-1/3)

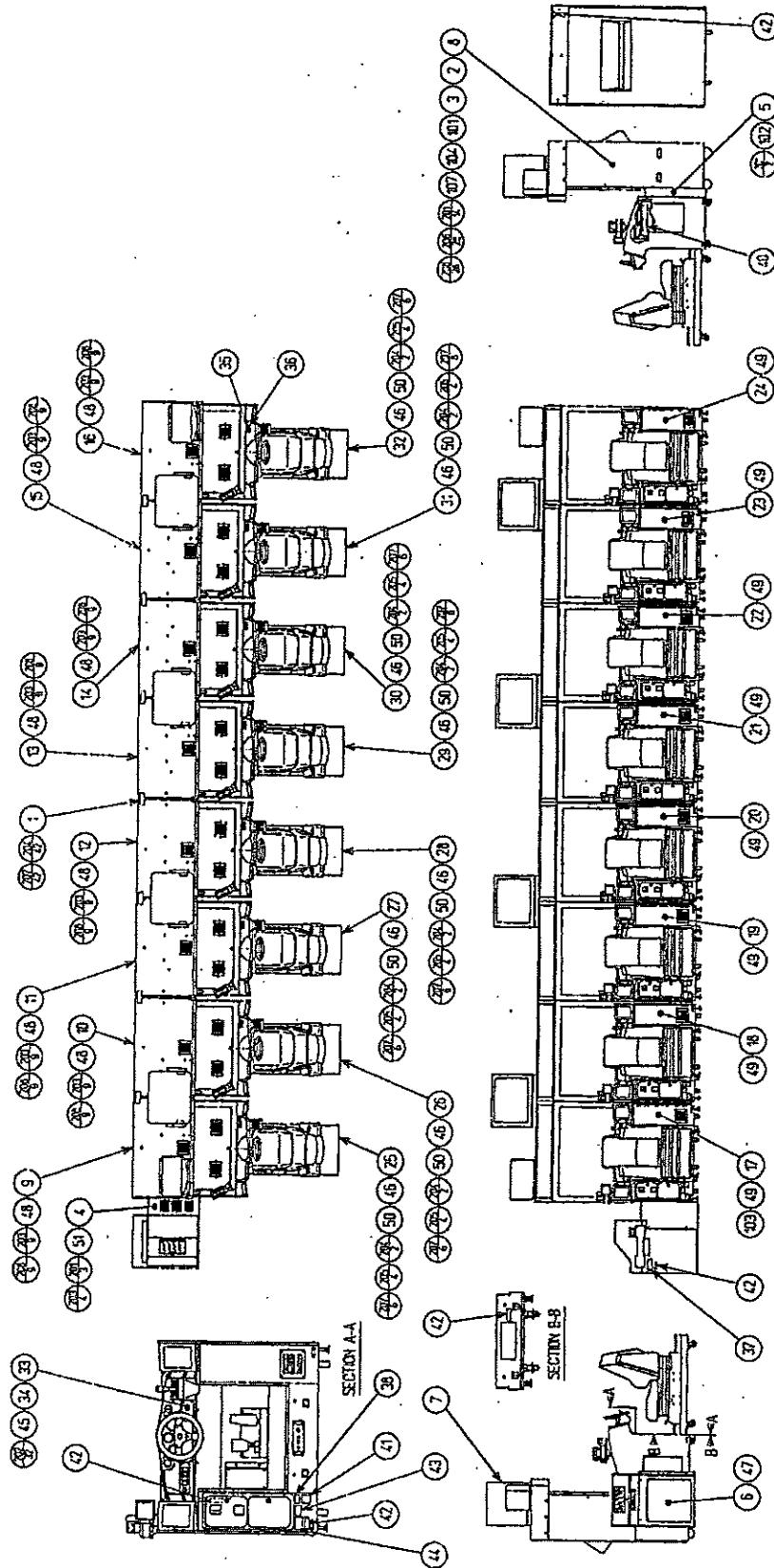



① TOP ASSY DAYTONA USA SPCL 8P

(D-2/3)

ITEM NO.	PART NO.	DESCRIPTION	NOTE
1	DSP-0001	JOINT HOLDER	
2	DSP-0002	WIRE COVER A	
3	DSP-0003	WIRE COVER B	
4	DSP-0004	TOWER SPACER	
5	DSP-0005	SIDE LID	
6	DSP-0100	ASSY CONTROL TOWER	
7	DSP-0200	ASSY OPTION PARTS	
8	DSP-0500	ASSY PTV	
9	DSP-0600-01	ASSY BILLBOARD RED	
10	DSP-0600-02	ASSY BILLBOARD BLUE	
11	DSP-0600-03	ASSY BILLBOARD YELLOW	
12	DSP-0600-04	ASSY BILLBOARD GREEN	
13	DSP-0600-05	ASSY BILLBOARD BLACK	
14	DSP-0600-06	ASSY BILLBOARD PINK	
15	DSP-0600-07	ASSY BILLBOARD SKY BLUE	
16	DSP-0600-08	ASSY BILLBOARD ORANGE	
17	DSP-1000-01	ASSY FRONT CABI RED	
18	DSP-1000-02	ASSY FRONT CABI BLUE	
19	DSP-1000-03	ASSY FRONT CABI YELLOW	
20	DSP-1000-04	ASSY FRONT CABI GREEN	
21	DSP-1000-05	ASSY FRONT CABI BLACK	
22	DSP-1000-06	ASSY FRONT CABI PINK	
23	DSP-1000-07	ASSY FRONT CABI SKY BLUE	
24	DSP-1000-08	ASSY FRONT CABI ORANGE	
25	DSP-2000-01	ASSY REAR CABI RED	
26	DSP-2000-02	ASSY REAR CABI BLUE	
27	DSP-2000-03	ASSY REAR CABI YELLOW	
28	DSP-2000-04	ASSY REAR CABI GREEN	
29	DSP-2000-05	ASSY REAR CABI BLACK	
30	DSP-2000-06	ASSY REAR CABI PINK	
31	DSP-2000-07	ASSY REAR CABI SKY BLUE	
32	DSP-2000-08	ASSY REAR CABI ORANGE	
33	DYN-0010	DENOMI PLATE	
34	421-5800-226	ORIGINAL SEAL DAYTONA	
38	421-6594-91	STICKER CERTIFICATE	
40	421-6709	STICKER SERVICE INSTR ENG	
42	421-7988-91	STICKER SERIAL NUMBER	
48	421-7937	STICKER EMI	
44	421-7987	STICKER BLBC SPEC	OTHERS
	421-8408	STICKER BLBC SPEC FOR TAIWAN	TAIWAN
45	421-7308~	DENOMINATION SHEET 1GAME~	
46	421-8479-01	STICKER INSTR SUNLIGHT ENG	
47	SGM-3450	POLYETHYLENE COVER 600×900×900	
48	SGM-2318	POLYETHYLENE COVER 1000×1000×500	
49	SGM-3791	POLYETHYLENE COVER 900×1100×1000	
50	SGM-2032	POLYETHYLENE COVER 750×1400×950	
51	DSP-0011	SIDE LID S	
101	600-6275-0500	ASSY FIBER CABLE φ5 0500CM	
102	601-6718	AIR JOINT 10-10 P TYPE	
103	601-6932	AIR JOINT 10 PLUG	
104	601-6844-81600	AIR TUBE φ10-BLACK-1600	
105	601-6844-8020M	AIR TUBE φ10-BLACK-20M	

① TOP ASSY DAYTONA USA SPCL 8P

(D-3/3)

ITEM NO.	PART NO.	DESCRIPTION	NOTE
107	601-6844-81050	AIR TUBE $\phi$ 10-BLACK-1050	
201	000-T00408-0B	M SCR TH BLK M4 $\times$ 8	
202	000-T00416-0C	M SCR TH CRM M4 $\times$ 16	
203	000-T00520-0B	M. SCR TH BLK M5 $\times$ 20	
204	030-000830-SB	HEX BLT W/S BLK M8 $\times$ 30	
205	030-000850-SB	HEX BLT W/S BLK M8 $\times$ 50	
206	050-F00500	FLG NUT M5	
207	060-F00800-0B	FLT WSHR BLK M8	
208	068-552016-0B	FLT WSHR BLK 5.5-20 $\times$ 1.6	
301	600-6448-44	WIRE HARN AC200V SPLY 1-4	
302	600-6448-45	WIRE HARN AC200V SPLY 5-8	
303	600-6448-46	WIRE HARN STATES SIGNAL 1-4	
304	600-6448-47	WIRE HARN STATES SIGNAL 5-8	
305	600-6448-48	WIRE HARN CCD INPUT 1-4	
306	600-6448-49	WIRE HARN CCD INPUT 5-8	
307	600-6448-54-91	WIRE HARN COMPRESSOR PWR	
401	601-6604-70	CARTON BOX 70	
402	420-6124-06	OWNERS MANUAL DAYTONA USA SP BNG	
403	SGM-2675	POLYBTHYLENE BAG 240 $\times$ 370	
404	220-5381	KBY MASTER FOR 220-5380	
405	SGM-4111	KBY BAG	
406	540-0009-01	WRBNCH FOR TAMP PRF SCR DUAL TYPE M8	
407	540-0007-01	WRBNCH FOR TAMP PRF SCR DUAL TYPE M5	
408	220-5373	VOL CONT B-5K OHM	
	220-5484	VOL CONT B-5K OHM	
409	200-5297	REMOTE CONTROLLER H	For HITACHI PROJECTOR
	200-5298	REMOTE CONTROLLER M	For MITSUBISHI PROJECTOR.
412	509-5566	SW MICRO TYPE (OMRON SS-5GLT)	
413	514-5036-7000	FUSE 6.4 $\phi$ $\times$ 30 7000mA 125V	
414	514-5036-15000	FUSE 6.4 $\phi$ $\times$ 30 15000mA 125V	
415	DSP-0006	STICKER UPPER TV	
416	DSP-0007	STICKER TV SIDE L	
417	DSP-0008	STICKER TV SIDE R	
418	DSP-0009	STICKER F CABI L	
419	DSP-0010	STICKER F CABI R	
420	421-8496	STICKER SIDE TV LOWER L	
421	421-8497	STICKER SIDE TV LOWER R	
	601-7861	AIR JOINT 10-1/2	
	601-6831	AIR JOINT 10-3/8	
	601-6083	AIR JOINT	
	601-7862	AIR REGULATER 3000 W/JOINT	
422	DSP-0120	CONNECT PLATE A	
423	600-6448-76	WIRE HARN TOWER L EXT	
424	280-5009	CORD CLAMP $\phi$ 21	

② TOP ASSY DAYTONA USA SPCL 4P

(D-1/3)

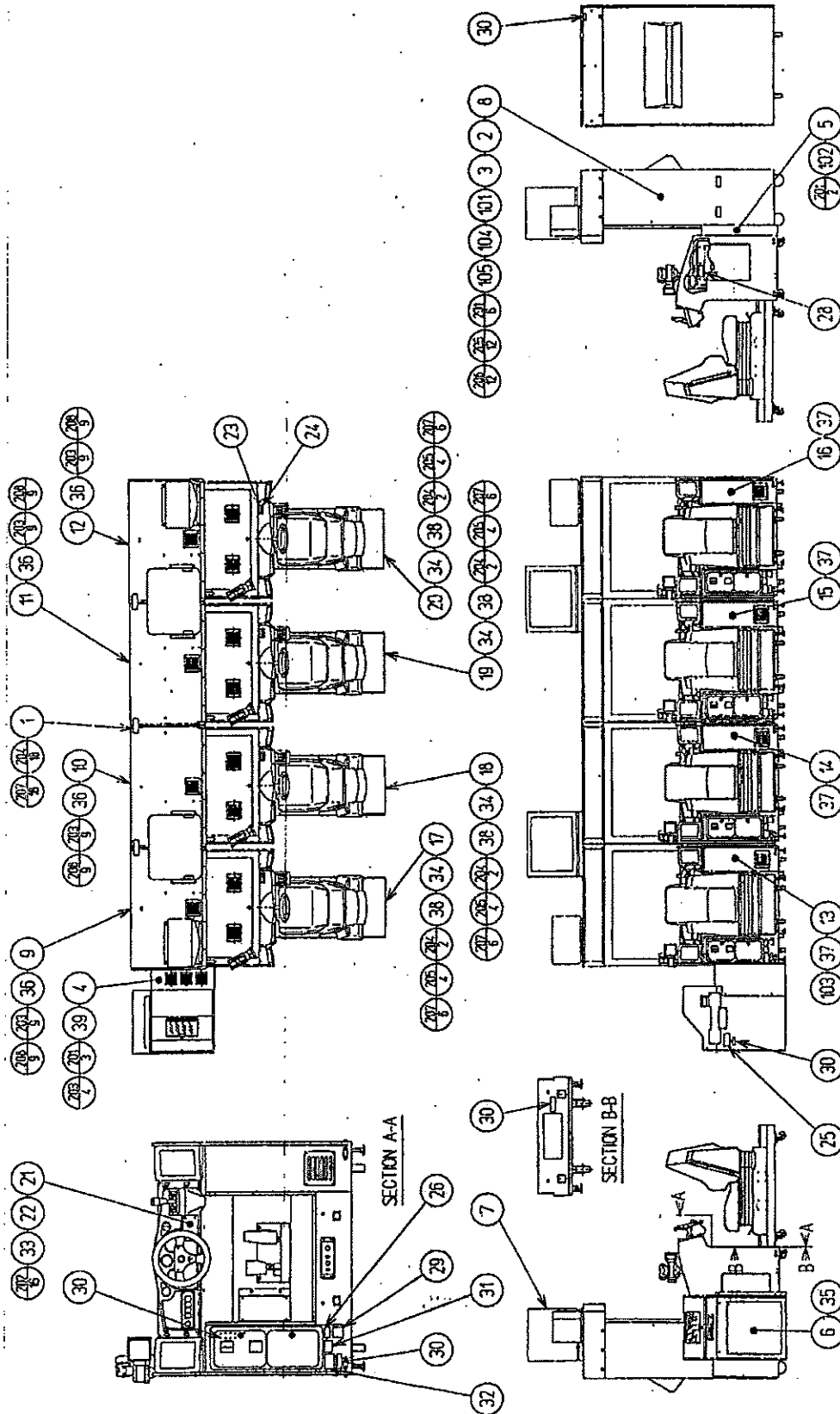

② TOP ASSY DAYTONA USA SPCL 4P

(D-2/3)

ITEM NO.	PART NO.	DESCRIPTION	NOTE
1	DSP-0001	JOINT HOLDER	
2	DSP-0002	WIRE COVER A	
3	DSP-0003	WIRE COVER B	
4	DSP-0004	TOWER SPACBR	
5	DSP-0005	SIDE LID	
6	DSP-0100	ASSY CONTROL TOWER	
7	DSP-0250	ASSY OPTION PARTS 4P	
8	DSP-0500	ASSY PTV	
9	DSP-0600-01	ASSY BILLBOARD RED	
10	DSP-0600-02	ASSY BILLBOARD BLUE	
11	DSP-0600-03	ASSY BILLBOARD YELLOW	
12	DSP-0600-04	ASSY BILLBOARD GREEN	
13	DSP-1000-01	ASSY FRONT CABI RED	
14	DSP-1000-02	ASSY FRONT CABI BLUE	
15	DSP-1000-03	ASSY FRONT CABI YELLOW	
16	DSP-1000-04	ASSY FRONT CABI GREEN	
17	DSP-2000-01	ASSY REAR CABI RED	
18	DSP-2000-02	ASSY REAR CABI BLUE	
19	DSP-2000-03	ASSY REAR CABI YELLOW	
20	DSP-2000-04	ASSY REAR CABI GREEN	
21	DYN-0010	DENOMI PLATE	
22	421-5800-226	ORIGINAL SEAL DAYTONA	
26	421-6594-91	STICKER CERTIFICATE	
28	421-6709	STICKER SERVICE INSTR ENG	
30	421-7988-91	STICKER SERIAL NUMBER	
32	421-7987	STICKER BLEC SPEC	
33	421-7308~	DENOMINATION SHBET 1GAME~	
34	421-8479-01	STICKER INSTR SUNLIGHT ENG	
35	SGM-8450	POLTHN COV 600×900×900	
36	SGM-2318	POLYETHYLENE COVER 1000×1000×500	
37	SGM-3791	POLYETHYLENE COVER 900×1100×1000	
38	SGM-2032	POLYETHYLENE COVER 750×1400×950	
39	DSP-0011	SIDE LID S	
101	600-6275-0500	ASSY FIBER CABLE $\phi$ 5 0500CM	
102	601-6718	AIR JOINT 10-10 P TYPE	
103	601-6932	AIR JOINT 10 PLUG	
104	601-6844-81050	AIR TUBE $\phi$ 10-BLACK-1050	
105	601-6844-81600	AIR TUBE $\phi$ 10-BLACK-1600	
106	601-6844-8020M	AIR TUBE $\phi$ 10-BLACK-20M	
201	000-T00408-0B	M SCR TH BLK M4×8	
202	000-T00416-0C	M SCR TH CRM M4×16	
203	000-T00520-0B	M SCR TH BLK M5×20	
204	030-000830-SB	HEX BLT W/S BLK M8×30	
205	030-000850-SB	HEX BLT W/S BLK M8×50	
206	050-F00500	FLG NUT M5	
207	060-F00800-0B	FLT WSHR BLK M8	
208	068-552016-0B	FLT WSHR BLK 5.5-20×1.6	
301	600-6448-44	WIRE HARN AC200V SPLY 1-4	
302	600-6448-46	WIRE HARN STATES SIGNAL 1-4	

② TOP ASSY DAYTONA USA SPCL 4P

(D-3/3)

ITEM NO.	PART NO.	DESCRIPTION	NOTE
303	600-6448-48	WIRE HARN CCD INPUT 1-4	
304	600-6448-54-91	WIRE HARN COMPRESSOR PWR	
401	601-6604-70	CARTON BOX 70	
402	420-6124-06	OWNERS MANUAL DAYTONA USA SP ENG	
403	SGM-2675	POLYETHYLENE BAG 240×370.	
404	220-5381	KEY MASTER FOR 220-5380	
405	SGM-4111	KEY BAG	
406	540-0009-01	WRENCH FOR TAMP PRF SCR DUAL TYPE M8	
407	540-0007-01	WRENCH FOR TAMP PRF SCR DUAL TYPE M5	
408	220-5373	VOL CONT B-5K OHM	
	220-5484	VOL CONT B-5K OHM	
409	200-5297	REMOTE CONTROLLER H	For HITACHI PROJECTOR
	200-5298	REMOTE CONTROLLER M	For MITSUBISHI PROJECTOR
412	509-5566	SW MICRO TYPE (OMRON SS-5GLT)	
413	514-5036-7000	FUSE 6.4φ × 30 7000mA 125V	
414	514-5036-15000	FUSE 6.4φ × 30 15000mA 125V	
415	DSP-0006	STICKER UPPER TV	
416	DSP-0007	STICKER TV SIDE L	
417	DSP-0008	STICKER TV SIDE R	
418	DSP-0009	STICKER F CABI L	
419	DSP-0010	STICKER F CABI R	
420	421-8496	STICKER SIDE TV LOWER L	
421	421-8497	STICKER SIDE TV LOWER R	
	601-7861	AIR JOINT 10-1/2	
	601-6831	AIR JOINT 10-3/8	
	601-6083	AIR JOINT	
	601-7862	AIR REGULATOR 3000 W/JOINT	
422	DSP-0120	CONNECT PLATE A	
423	600-6448-76	WIRE HARN TOWER L EXT	
424	280-5009	CORD CLAMP φ21	

③ ASSY CONTROL TOWER (DSP-0100)

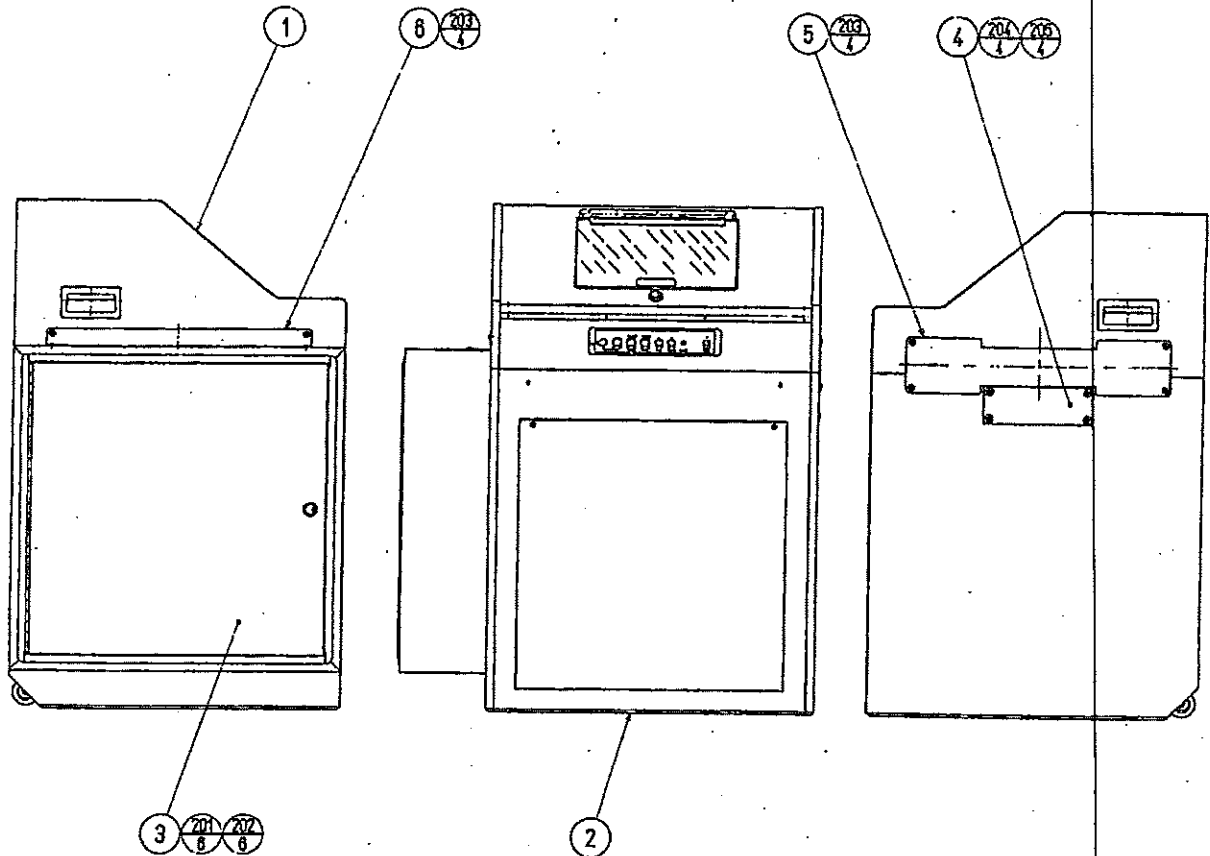

ITEM NO.	PART NO.	DESCRIPTION	NOTE
1	DSP-0110	ASSY CONTROL TOWER U	
2	DSP-0140	ASSY CONTROL TOWER L	
3	DSP-0180	ASSY BREAKER BOX	
4	DSP-0101	WIRE HOLE LID	
5	DSP-0102	CONNECT PLATE A	
6	DSP-0103	CONNECT PLATE B	
201	000-P00520-S	M SCR PH W/S M5×20	
202	068-552016	FLT WSHR 5, 5-20×1, 6	
203	000-T00520-OB	M SCR TH BLK M5×20	
204	000-T00425-OB	M SCR TH BLK M4×25	
205	068-441616-OB	FLT WSHR BLK 4, 4-1, 6×1, 6	

④ ASSY CONTROL TOWER U (DSP-0110)

(D-1/2)

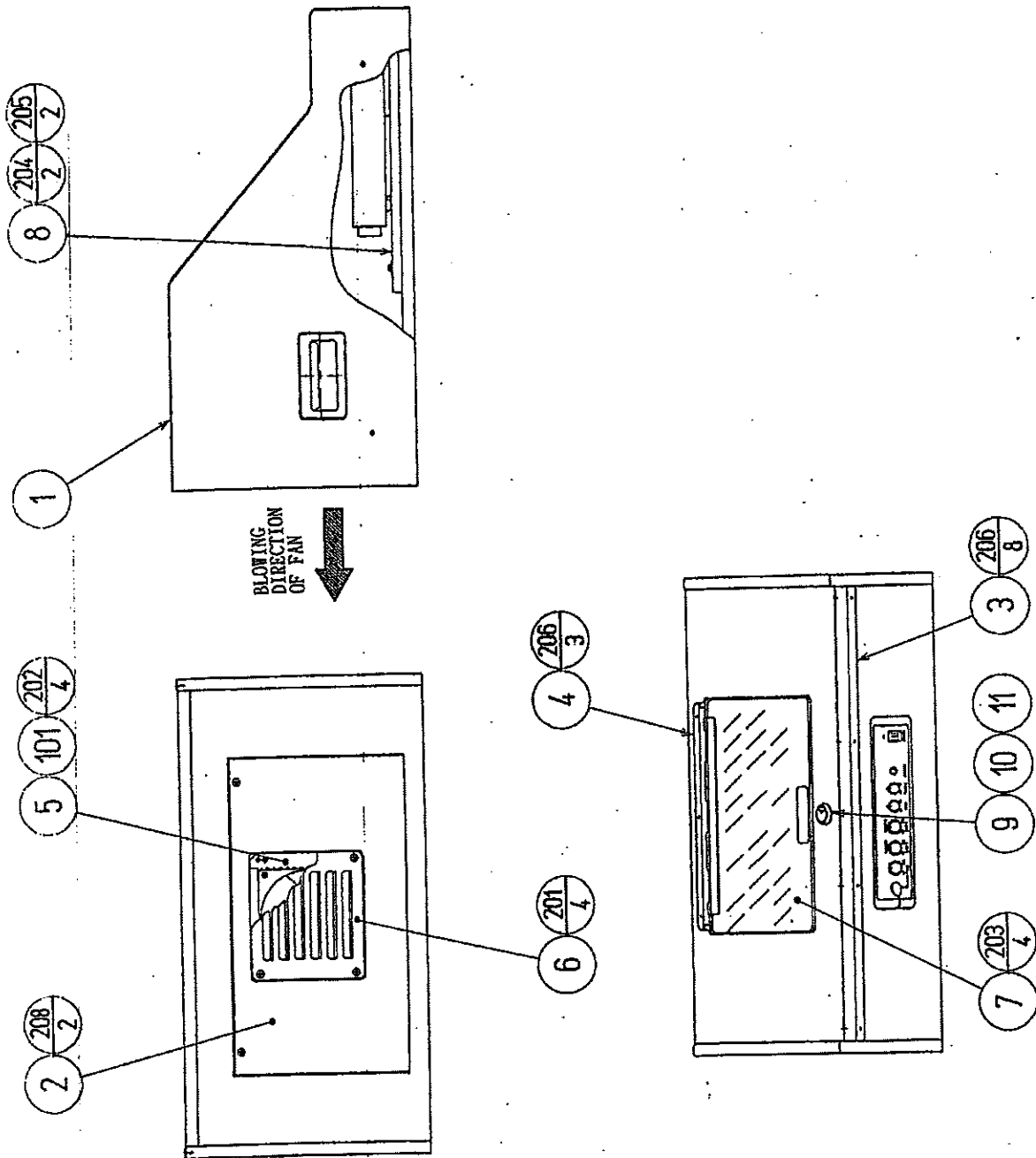

④ ASSY CONTROL TOWER U (DSP-0110)

(D-2/2)

ITEM NO.	PART NO.	DESCRIPTION	NOTE
1	DSP-0111	CONTROL TOWER U	
2	DSP-0112	SERVICE DOOR U	
3	DSP-0113	EDGE GUARD	
4	DSP-0114	HOLE GUARD	
5	HN-1042X	FAN BRKT	
6	UP-1018	AIR VENT	
7	DSP-0130	ASSY SERVICE PANEL	
8	DSP-4300	ASSY AMP BASE	
9	220-5380	MAG LOCK MASTER W/O KBY	
10	117-0062	PLATE LOCK RETAINER	
11	DP-1148X	LKG TNG	
101	260-0011-02	AXIAL FLOW FAN AC100V 50-60Hz	
102	280-5009	CORD CLAMP $\phi$ 21	-01 also acceptable.
103	601-0460	PLASTIC TIE BBLT 100MM	
201	000-T00416-0B	M SCR TH BLK M4 $\times$ 16	
202	000-P00312-W	M SCR PH W/FS M3 $\times$ 12	
203	000-F00516	M SCR FH M5 $\times$ 16	
204	000-P00425-W	M SCR PH W/FS M4 $\times$ 25	
205	068-441616	FLT WSHR 4, 4-16 $\times$ 1.6	
206	079-000008	SCR NAIL THH STNLS 1.5 $\times$ 16	
207	011-F00310	TAP SCR FH 3 $\times$ 10	
208	000-T00425-0B	M SCR TH BLK M4 $\times$ 25	
301	600-6448-08	WIRE HARN FAN MOTOR U	
302	600-6448-13	WIRE HARN EXT SPEAKER U	
303	600-6448-21	WIRE HARN EXT ENTRY LAMP B	
304	600-6448-22	WIRE HARN EXT ENTRY SW B	
305	600-6448-23	WIRE HARN EXT PANEL SW B	
306	600-6448-42	WIRE HARN AMP PWR EXT	



⑤ ASSY SERVICE PANEL (DSP-0130)

(D-1/2)

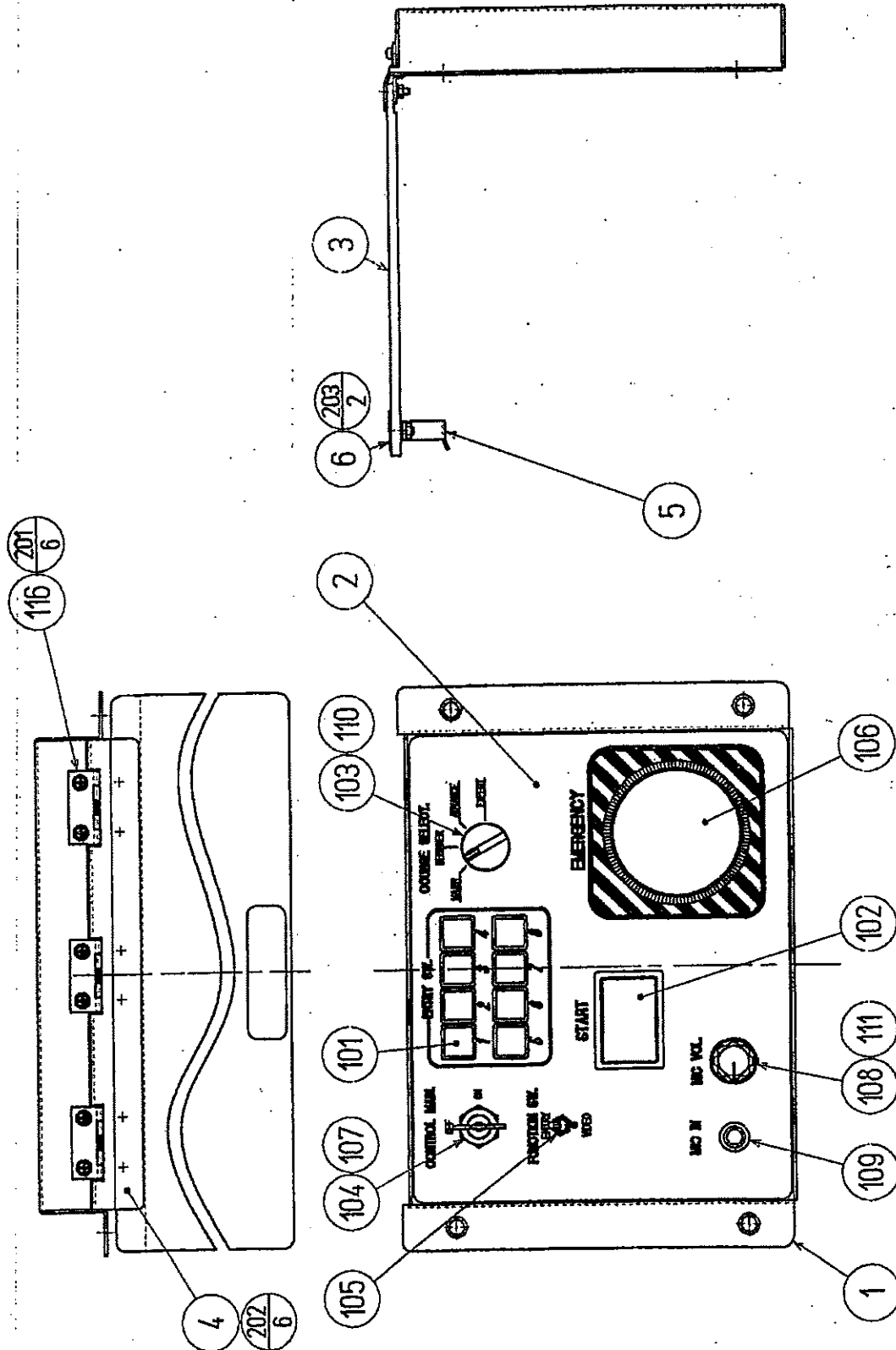

⑤ ASSY SERVICE PANEL (DSP-0130)

(1-2/2)

ITEM NO.	PART NO.	DESCRIPTION	NOTE
1	DSP-0131	SERVICE PANEL	
2	DSP-0132	PANEL STICKER	
3	DSP-0133	PANEL LID	
4	DSP-0134	HINGE GUARD	
5	DSP-0135	LOCK BRKT	
6	DSP-0136	LOCK BRKT HOLDER	
101	509-5255-R	SW PUSH BUTTON W/L (MS-730)	
102	509-5395-YE	SW PUSH BUTTON MR 12V YELLOW	
103	509-5624	ROTARY SW 4P (SRF114-2)	
104	509-5347	KEY SW DS-770 2P No.302	
105	509-5506	TOGGLE SW	
106	509-5348	SW PUSH RED (ABGD410N-R)	
107	220-5347	KEY FOR DS-770 2P No.302	
108	220-5219	RHEO STAT 100 OHM 10W (RVF10L 20F)	
109	210-5138	PHONE JACK (MJ-185LP)	
110	601-7782	KNOB K-54	
111	601-7786	KNOB (K-5475 MT30)	
112	310-5029-F20	SUMITUBE F F20MM	
113	280-5009	CORD CLAMP $\phi$ 21	$\phi$ 4
114	280-0425	CORD CLAMP $\phi$ 10	-01 also acceptable.
115	601-0460	PLASTIC TIE BELT 100MM	
116	250-5247	SPRING HINGE 38	
201	000-P00306-W	M SCR PH W/FS M3 $\times$ 6	
202	050-F00300	FLG NUT M3	
203	050-F00400	FLG NUT M4	
301	600-6448-24	WIRE HARN MIC VOL	
302	600-6448-25	WIRE HARN MIC	
303	600-6448-26	WIRE HARN ENTRY LAMP	
304	600-6448-27	WIRE HARN ENTRY SW	
305	600-6448-28	WIRE HARN PANEL SW	
306	600-6448-29	WIRE HARN PANEL SW GND	

⑥ ASSY CONTROL TOWER L (DSP-0140)

(D-1/2)

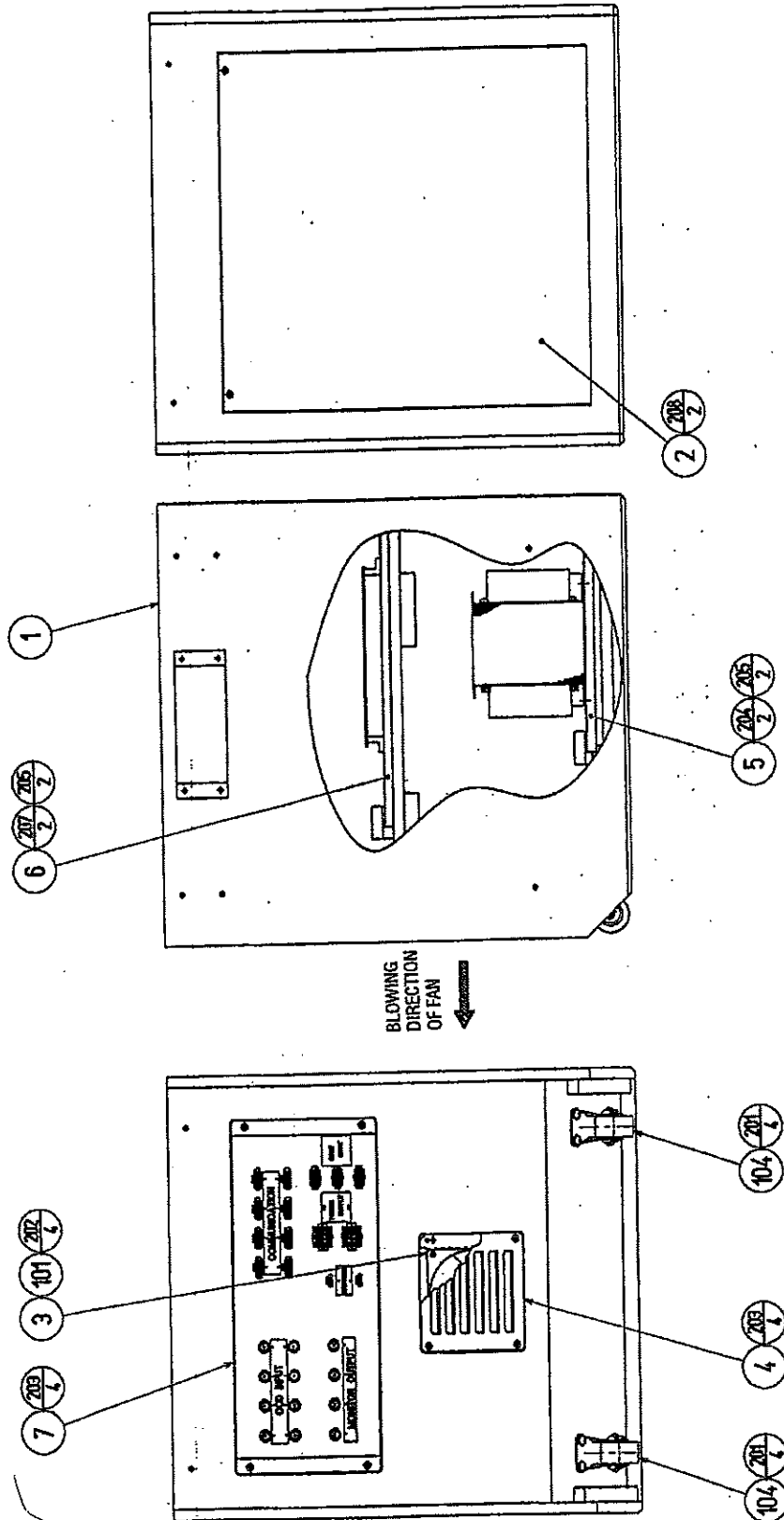

⑥ ASSY CONTROL TOWER L (DSP-0140)

(C-2/2)

ITEM NO.	PART NO.	DESCRIPTION	NOTE
1	DSP-0141	CONTROL TOWER L	
2	DSP-0142	SERVICE DOOR L	
3	HN-1042X	FAN BRKT	
4	UP-1018	AIR VENT	
5	DSP-4400	ASSY PWR SPLY TOWER	
6	DSP-4500	ASSY TOWER ELEC	
7	DSP-0170	ASSY CONNECTOR PANEL	
101	260-0011-02	AXIAL FLOW FAN AC100V 50-60Hz	
102	280-5009	CORD CLAMP $\phi$ 21	
103	601-0460	PLASTIC TIE BELT 100MM	-01 also acceptable.
104	601-6151-01	CASTER	
201	000-P00525-W	M SCR PH W/FS M5 $\times$ 25	
202	000-P00312-W	M SCR PH W/FS M3 $\times$ 12	
203	000-T00416-0B	M SCR TH BLK M4 $\times$ 16	
204	000-P00425-W	M SCR PH W/FS M4 $\times$ 25	
205	068-441616	FLT WSHR 4. 4-16 $\times$ 1.6	
206	011-F00310	TAP SCR PH 3 $\times$ 10	
207	000-P00430	M SCR PH W/FS M4 $\times$ 30	
208	000-T00425	M SCR TH BLK M4 $\times$ 25	
301	600-6448-07	WIRE HARN FAN AC	
302	600-6448-09	WIRE HARN EXT DC	
303	600-6448-18	WIRE HARN EXT ENTRY LAMP A	
304	600-6448-19	WIRE HARN EXT ENTRY SW A	
305	600-6448-20	WIRE HARN EXT PANEL SW A	
306	600-6448-36	WIRE HARN EXT AC100V	
307	600-6448-39	WIRE HARN EXT SPEAKER L	
308	600-6448-63	WIRE HARN AC200V EXT	

⑦ ASSY CONNECTOR PANEL (DSP-0170)

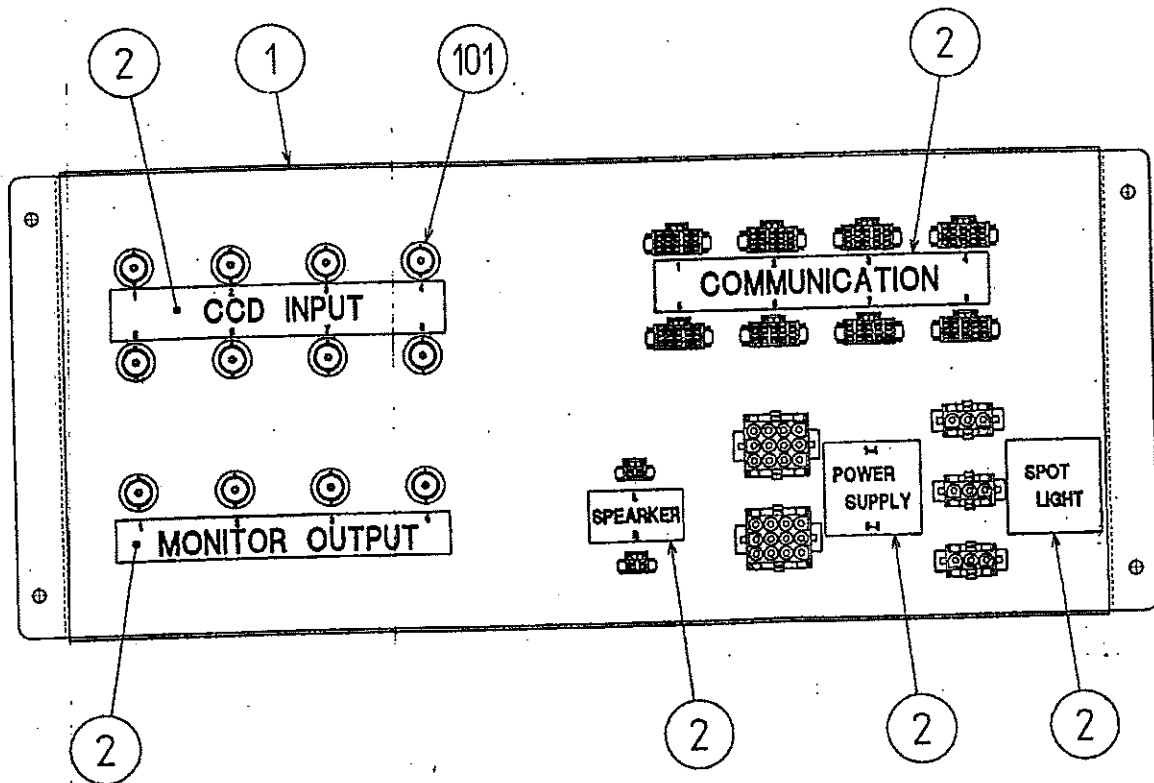

ITEM NO.	PART NO.	DESCRIPTION	NOTE
1	DSP-0171	CONNECTOR BRKT	
2	421-8710	STICKER CONNECTOR PANEL DSP	
101	211-5517	CONN BNC EXT PNL	
102	601-0460	PLASTIC TIE BELT 100MM	
301	600-6448-31	WIRE HARN 10P PANEL 1, 2	
302	600-6448-32	WIRE HARN 10P PANEL 3, 4	
303	600-6448-33	WIRE HARN 10P PANEL 5, 6	
304	600-6448-34	WIRE HARN 10P PANEL 7, 8	
305	600-6448-38	WIRE HARN SPEAKER OUT	
306	600-6448-40	WIRE HARN CCD IN	
307	600-6448-41	WIRE HARN CCD OUT	
308	600-6448-43	WIRE HARN SPOTLIGHT OUT	
309	600-6448-64	WIRE HARN AC200V. OUT	

⑧ ASSY BREAKER BOX (DSP-0180)

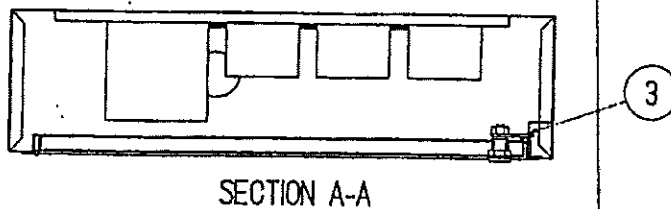

SECTION A-A

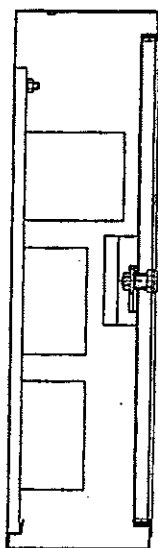

SECTION B-B

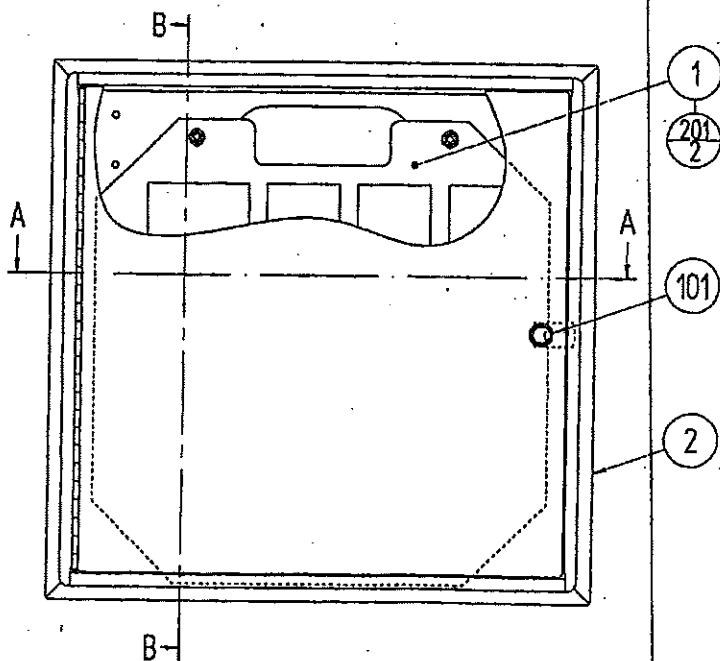

ITEM NO.	PART NO.	DESCRIPTION	NOTE
1	DSP-0190	ASSY BREAKER BASE	AC110V ARBA
	DSP-0190-01	ASSY BREAKER BASE $\phi$ 1 240V	AC240V ARBA
	DSP-0190-02	ASSY BREAKER BASE $\phi$ 1 220V	AC220V ARBA
2	DSP-0181	BREAKER BOX	
3	DP-1167	TNG LKG	
101	220-5380	MAG LOCK MASTER W/O KEY	
201	050-F00800	FLG NUT M8 S=12	

9 ASSY BREAKER BASE (DSP-0190)

(D-1/2)

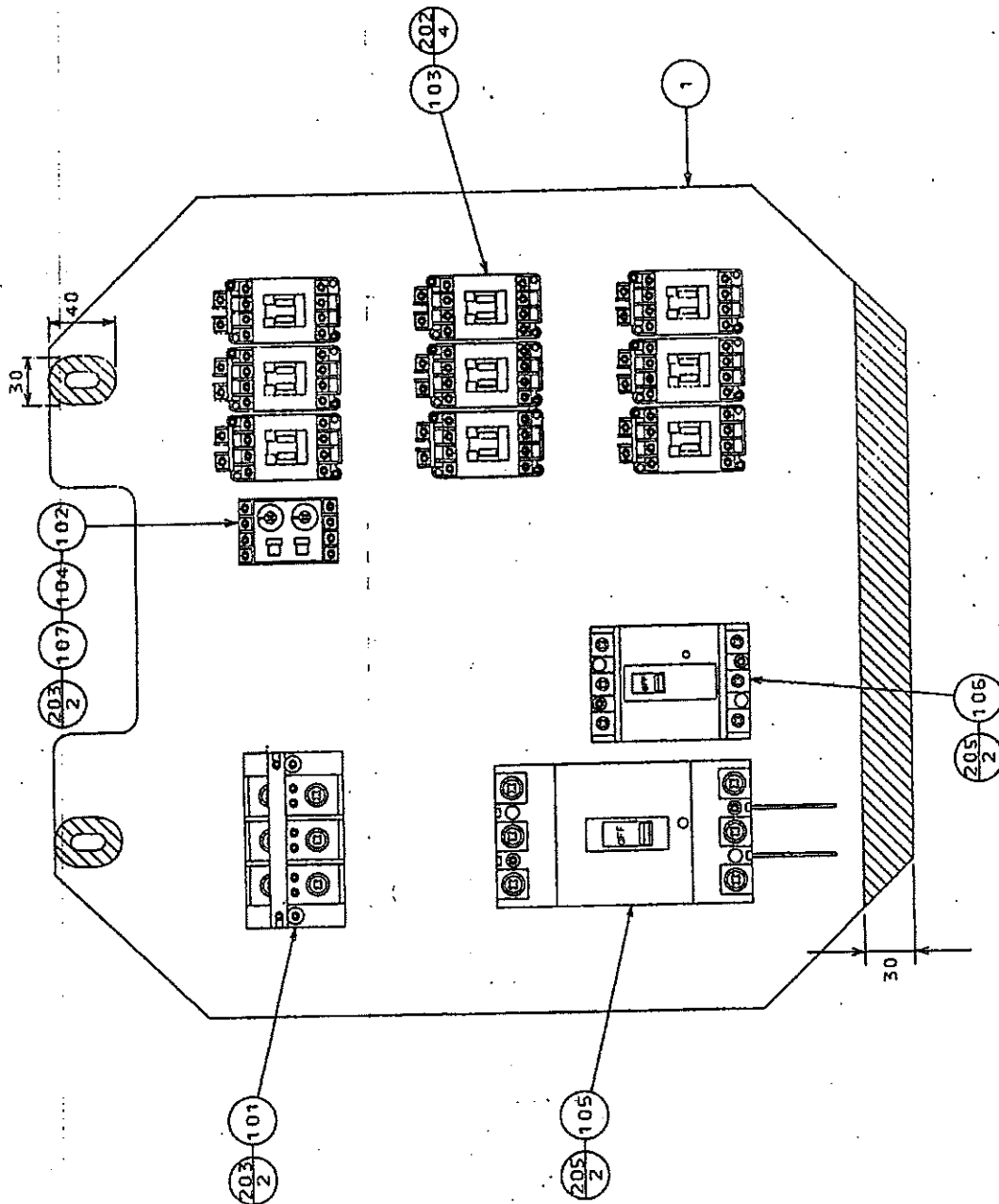

Make sure that there is no wiring, etc. in the slash mark portions.

⑨ ASSY BREAKER BASE (DSP-0190)

(D-2/2)

ITEM NO.	PART NO.	DESCRIPTION	NOTE
1	DSP-0191	BREAKER BASE	
101	117-5270	TERMINAL 100A 3P (ML-6855)	
102	214-0191	RELAY SOCKET (SR2P-06B)	
103	450-5092	MAGNET CONTACT SC-03 AC220V 1A	
104	450-5120	TIMBR RELAY GT3W-A11AF20	
105	512-5036	CIRCUIT BREAKER 60A (BBC3602)	
106	512-5037	MOTOR BREAKER 3.7KW (BBM316)	
107	601-7783	FIXED SPRING (SFA-202)	
108	280-5126	CORD CLAMP $\phi$ 25	
109	280-5009	CORD CLAMP $\phi$ 21	
110	280-0419	HARNSS LUG	-01 also acceptable.
111	601-0460	PLASTIC TIE BELT 100MM	
201	011-T03512	TAP SCR TH 3.5 $\times$ 12	
202	011-T03516	TAP SCR TH 3.5 $\times$ 16	
203	011-T03525	TAP SCR TH 3.5 $\times$ 25	
204	011-F00310	TAP SCR FH 3 $\times$ 10	
205	011-P00440	TAP SCR PH 4 $\times$ 40	
301	600-6448-55	WIRE HARN BREAKER BASE 1	
302	600-6448-56	WIRE HARN BREAKER BASE 2	
303	600-6448-57	WIRE HARN BREAKER BASE 3	
304	600-6448-58	WIRE HARN BREAKER BASE 4	
305	600-6448-59	WIRE HARN BREAKER BASE 5	
306	600-6448-60	WIRE HARN BREAKER BASE 6	
307	600-6448-61	WIRE HARN BREAKER BASE 7	
308	600-6448-62	WIRE HARN BREAKER BASE 8	



⑨ ASSY BREAKER BASE  $\phi$  1 240V (DSP-0190-01)

(D-1/2)

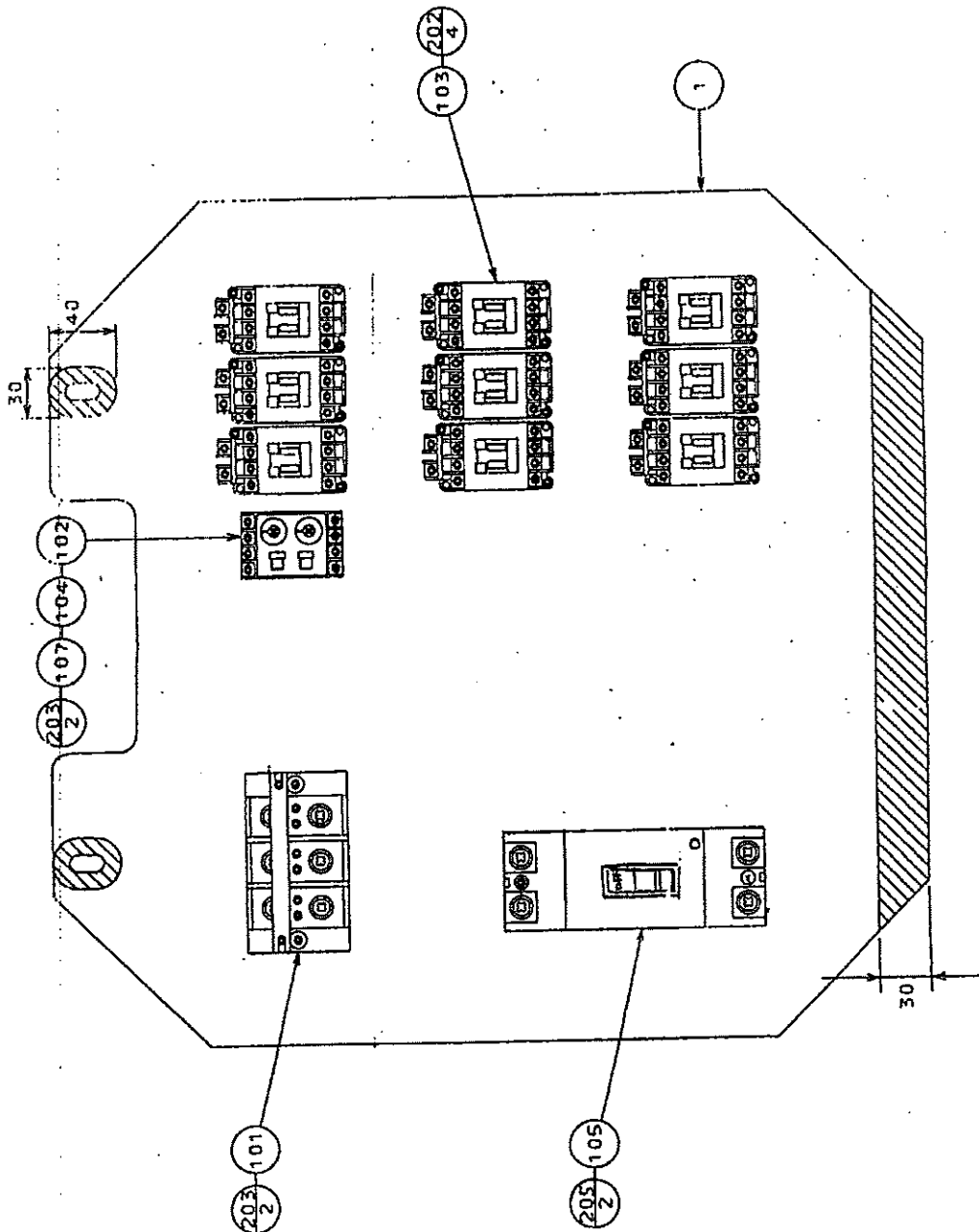

Make sure that there is no wiring, etc. in the slash mark portions.

⑨ ASSY BREAKER BASE  $\phi$  1 240V (DSP-0190-01)

(D-2/2)

ITEM NO.	PART NO.	DESCRIPTION	NOTE
1	DSP-0191	BREAKER BASE	
101	117-5270	TERMINAL 100A 3P (ML-6855)	
102	214-0191	RELAY SOCKET (SR2P-06B)	
103	450-5091	MAGNET CONTACT SC-03 AC240V 1A	
104	450-5120	TIMER RELAY GT3W-A11AF20	
105	512-5038	CIRCUIT BREAKER 50A (BBC2501)	
106	601-7783	FIXED SPRING (SFA-202)	
107	280-5126	CORD CLAMP $\phi$ 25	
108	280-5009	CORD CLAMP $\phi$ 21	
109	280-0419	HARNES LUG	
110	601-0460	PLASTIC TIE BELT 100MM	
201	011-T03512	TAP SCR TH 3.5 $\times$ 12	
202	011-T03516	TAP SCR TH 3.5 $\times$ 16	
203	011-T03525	TAP SCR TH 3.5 $\times$ 25	
204	011-F00310	TAP SCR PH 3 $\times$ 10	
205	011-P00440	TAP SCR PH 4 $\times$ 40	

⑨ ASSY BREAKER BASE  $\phi$  1 220V (DSP-0190-02)

(D-1/2)

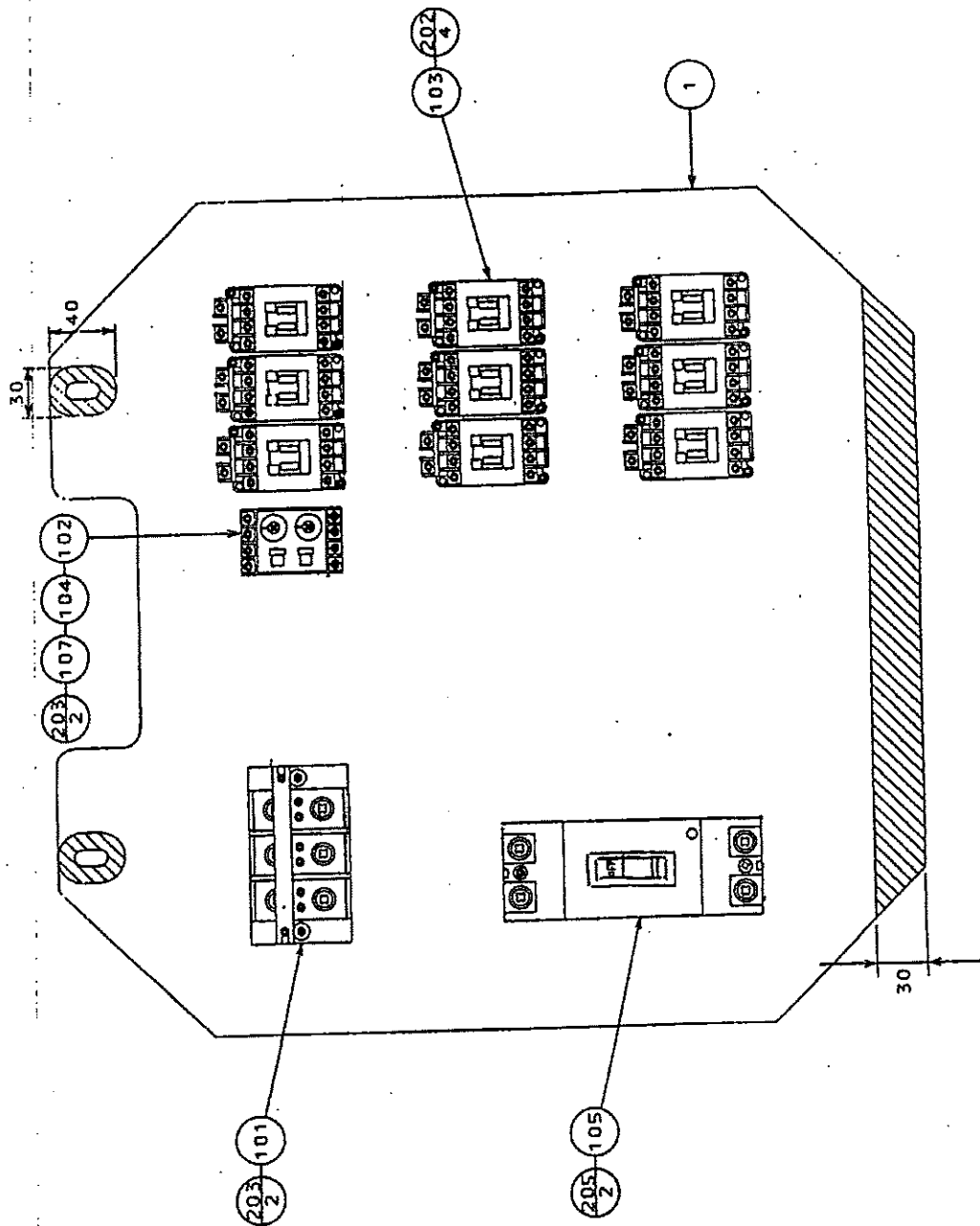

Make sure that there is no wiring, etc. in the slash mark portions.

⑨ ASSY BREAKER BASE  $\phi$  1 220V (DSP-0190-02)

(D-2/2)

ITEM NO.	PART NO.	DESCRIPTION	NOTE
1	DSP-0191	BREAKER BASE	
101	117-5270	TERMINAL 100A 3P (ML-6855)	
102	214-0191	RELAY SOCKET (SR2P-06B)	
103	450-5092	MAGNET CONTACT SC-03 AC220V 1A	
104	450-5120	TIMER RELAY GT3W-A11AF20	
105	512-5038	CIRCUIT BREAKER 50A (BBC2501)	
106	601-7783	FIXED SPRING (SFA-202)	
107	280-5126	CORD CLAMP $\phi$ 25	
108	280-5009	CORD CLAMP $\phi$ 21	
109	280-0419	HARNES LUG	
110	601-0460	PLASTIC TIE BELT 100MM	
201	011-T03512	TAP SCR TH 3.5 $\times$ 12	
202	011-T03516	TAP SCR TH 3.5 $\times$ 16	
203	011-T03525	TAP SCR TH 3.5 $\times$ 25	
204	011-F00310	TAP SCR FH 3 $\times$ 10	
205	011-P00440	TAP SCR PH 4 $\times$ 40	

⑩ ASSY OPTION PARTS (DSP-0200)

(D-1/2)

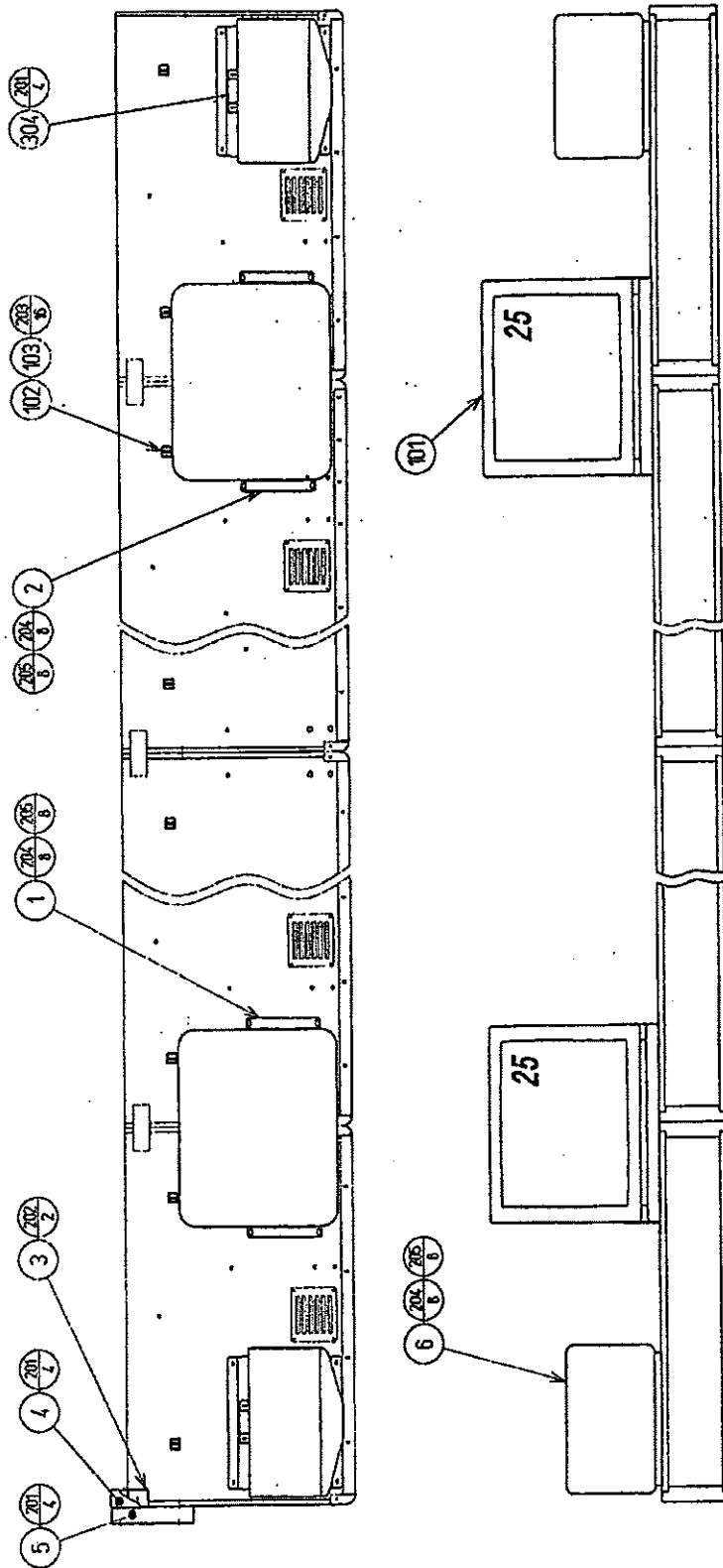

⑩ ASSY OPTION PARTS (DSP-0200)

(D-2/2)

ITEM NO.	PART NO.	DESCRIPTION	NOTE
1	DSP-0201	CRT FIX BRKT R	
2	DSP-0202	CRT FIX BRKT L	
3	DSP-0203	WIRE DUCT	
4	DSP-0204	DUCT COVER A	
5	DSP-0205	DUCT COVER B	
6	DSP-0210	ASSY SPEAKER	
101	200-5255	TV 25 TYPE 15K	
102	601-6583	TIE BELT HOLDER	
103	601-6582	PLASTIC TIEBELT 4.8×188	
201	000-T00412-0B	M SCR TH BLK M4×12	
202	011-T03512	TAP SCR TH 3.5×12	
203	011-F00312	TAP SCR FH 3×12	
204	030-000830-SB	HEX BLT W/S BLK M8×30	
205	060-F00800-0B	FLT WSHR BLK M8	
301	600-6448-50	WIRE HARN CCD OUTPUT 1-2	
302	600-6448-51	WIRE HARN CCD OUTPUT 3-4	
304	600-6448-53	WIRE HARN SPEAKER	

⑪ ASSY SPEAKER (DSP-0210)

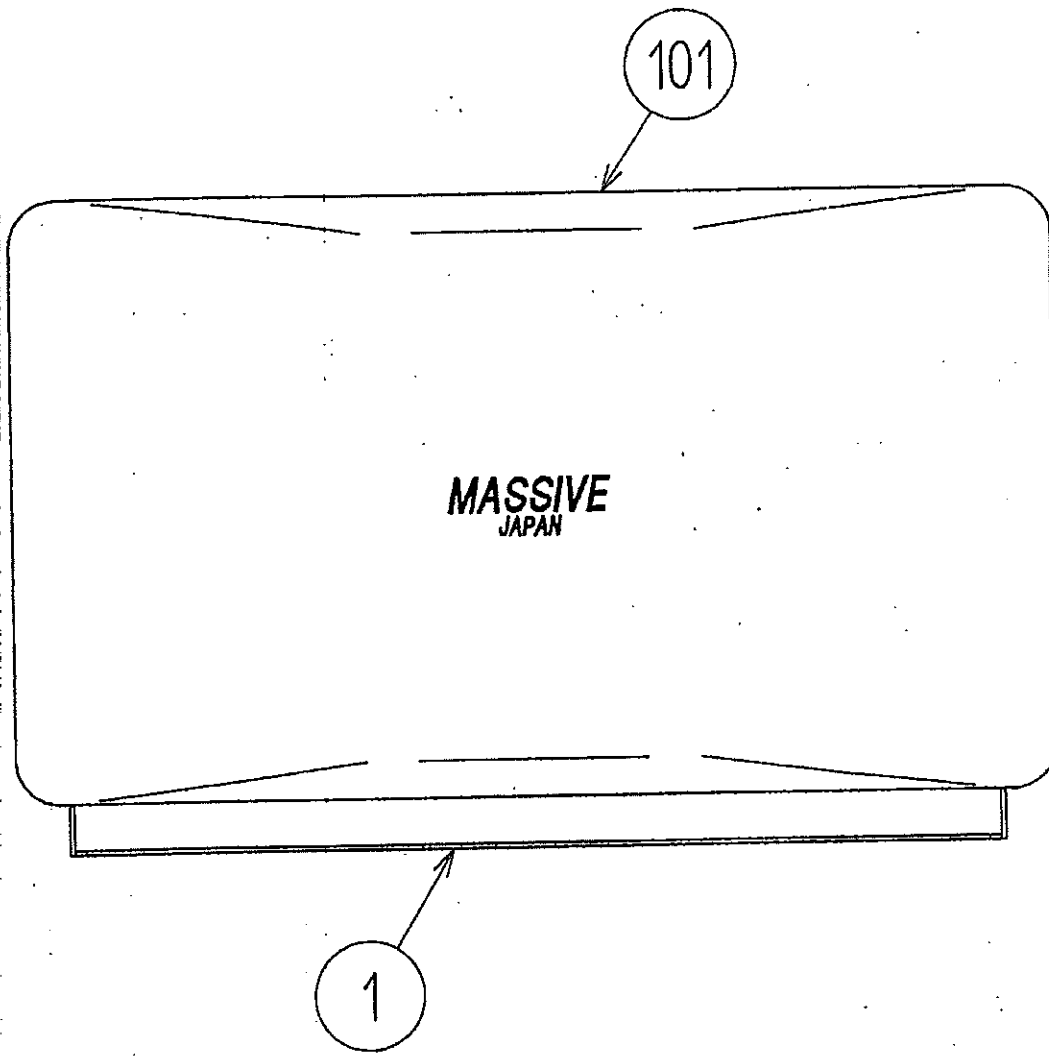

ITBM NO.	PART NO.	DESCRIPTION	NOTE
1	DSP-0211	SP MOUNT BRKT	
101	130-5105	SPEAKER BOX OE-800	

⑫ ASSY SPOT LIGHT (DSP-0220)

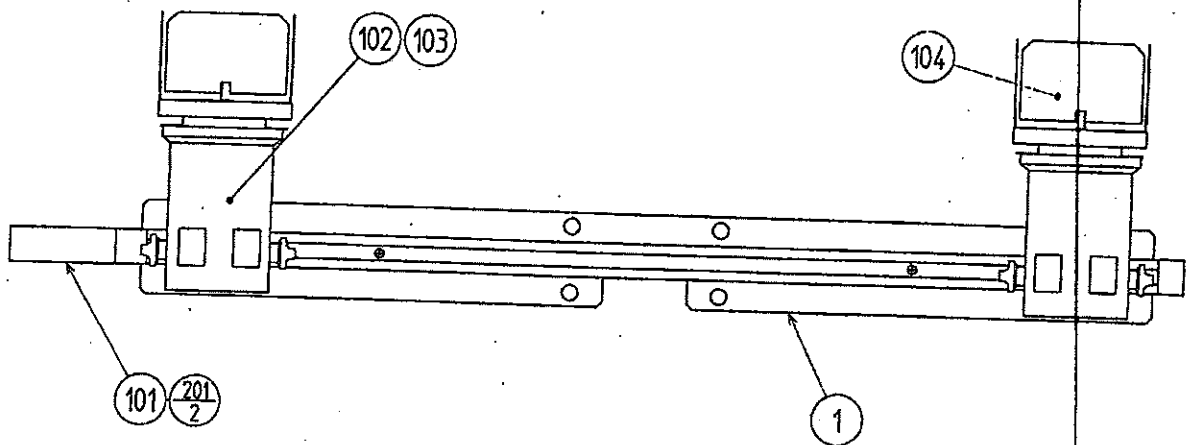

ITEM NO.	PART NO.	DESCRIPTION	NOTE
1	DSP-0221	RAIL MOUNT BRKT	
101	214-0179-01	PWR SPLY DUCT 01M SILVER	
102	214-0180	SPOT LIGHT 85W SILVER	
103	390-5455	HALOGEN LAMP 85W	
104	601-7110	BAN DOOR	
201	000-P00412-W	M SCR PH W/FS M4×12	



13 ASSY BANNER (DSP-0230)

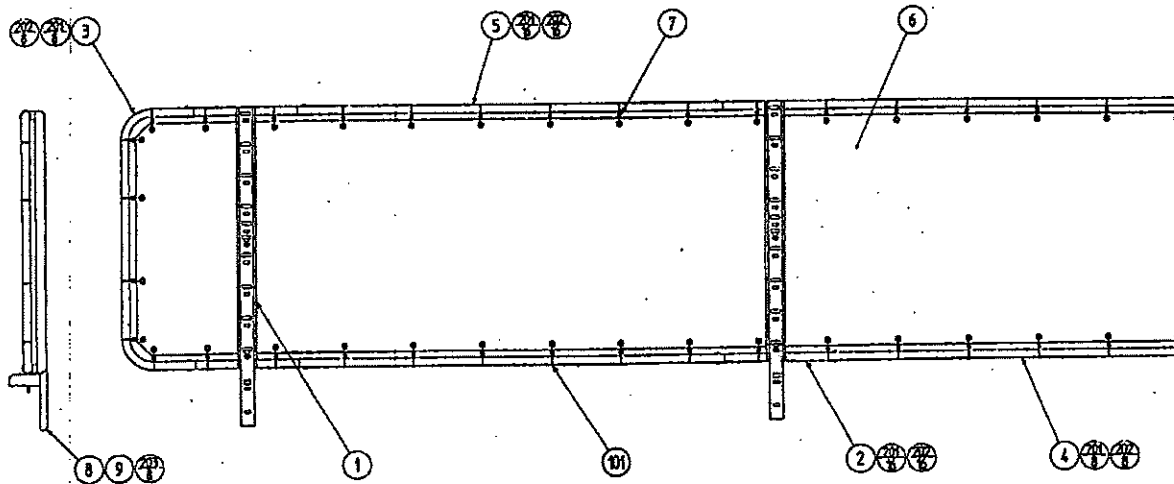

ITEM NO.	PART NO.	DESCRIPTION	NOTE
1	DSP-0231	FRAME BRACKET	
2	DSP-0232	JOINT PIPE	
3	DSP-0233	CORNER PIPE	
4	DSP-0234	PIPE A	
5	DSP-0235	PIPE B	
6	DSP-0236	BIG BANNER	
7	DSP-0237	SPRING HOOK	
8	DSP-0238	POLE BRACKET	
9	SLC-0006	FLT WASHER 8. 4-25×2	
101	601-7856	HOLDBR RING	
201	030-000616-SB	HEX BLT W/S BLK M6×16	
202	060-F00600-OB	FLT WSHR BLK M6	
203	030-000820-SB	HEX BLT W/S BLK M8×20	

⑭ ASSY OPTION PARTS 4P (DSP-0250)

(D-1/2)

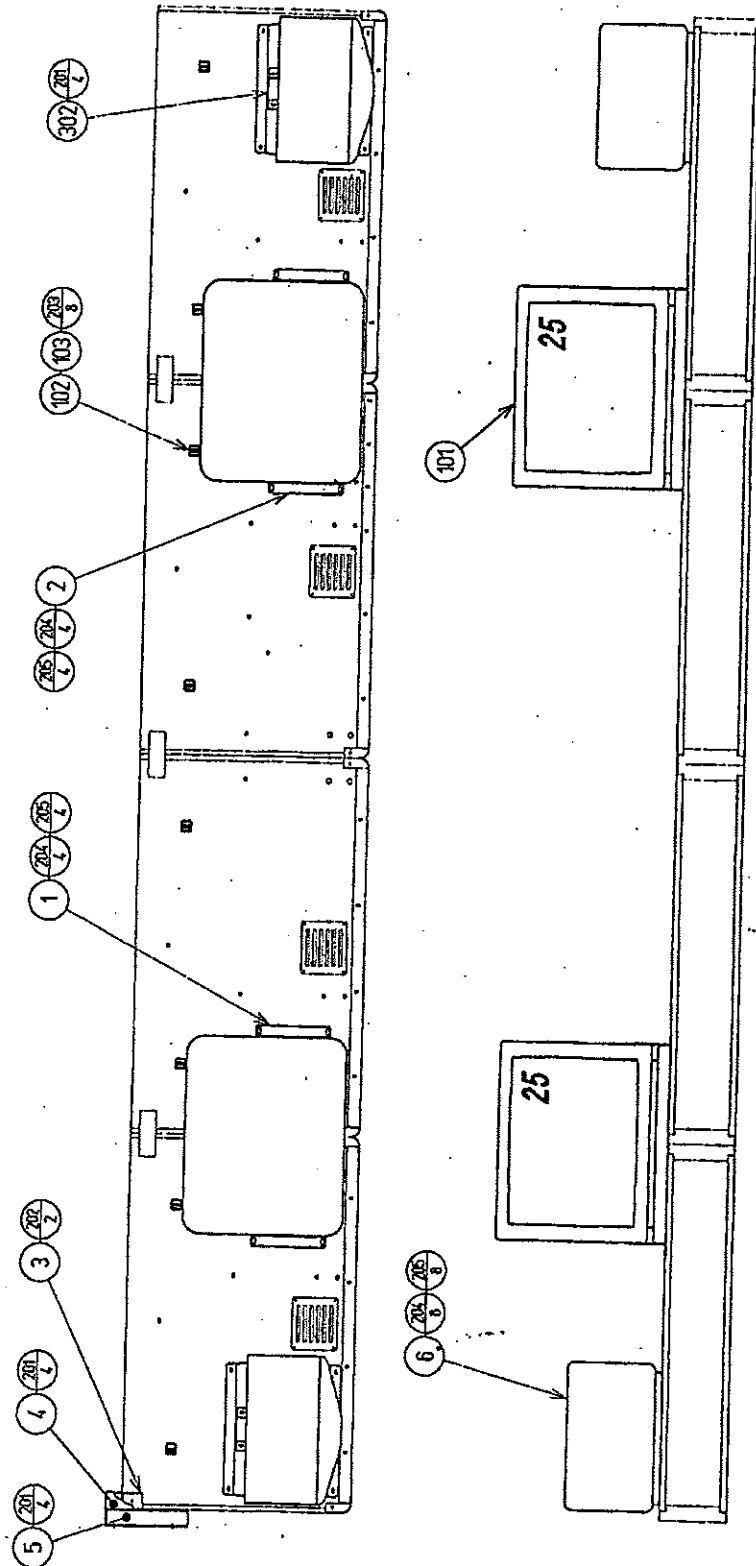

⑭ ASSY OPTION PARTS 4P (DSP-0250)

(D-2/2)

ITEM NO.	PART NO.	DESCRIPTION	NOTE
1	DSP-0201	CRT FIX BRKT R	
2	DSP-0202	CRT FIX BRKT L	
3	DSP-0203	WIRE DUCT	
4	DSP-0204	DUCT COVER A	
5	DSP-0205	DUCT COVER B	
6	DSP-0210	ASSY SPEAKER	
101	200-5255	TV 25 TYPE 15K	
102	601-6583	TIE BELT HOLDER	
103	601-6582	PLASTIC TIEBELT 4.8×188	
201	000-T00412-0B	M SCR TH BLK M4×12	
202	011-T03512	TAP SCR TH 3.5×12	
203	011-F00312	TAP SCR PH 3×12	
204	030-000830-SB	HEX BLT W/S BLK M8×30	
205	060-F00800-0B	FLT WSHR BLK M8	
301	600-6448-50	WIRE HARN CCD OUTPUT 1-2	
302	600-6448-65	WIRE HARN SPEAKER 4P	

⑮ ASSY BANNER 4P. (DSP-0260)

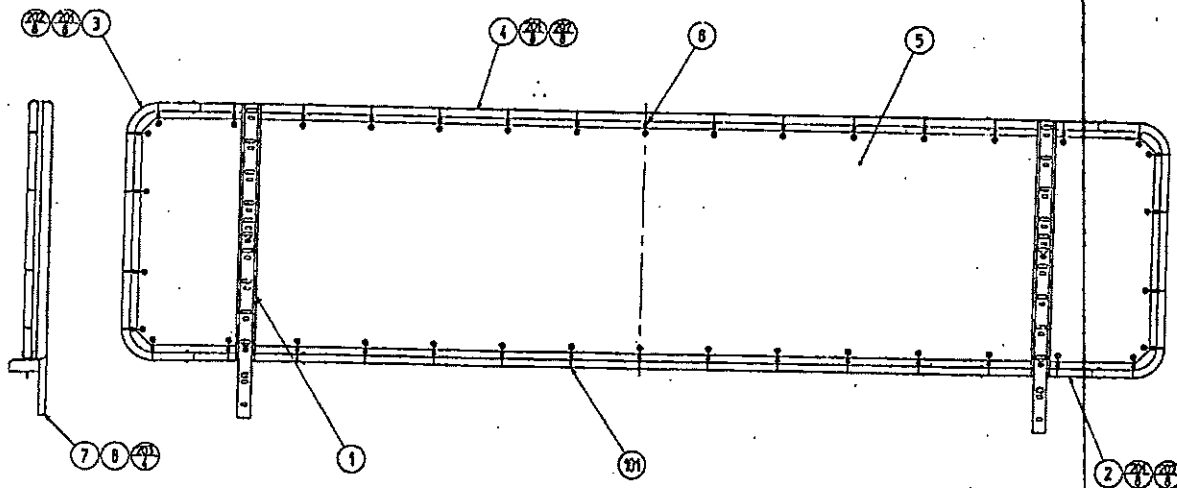

ITEM NO.	PART NO.	DESCRIPTION	NOTE
1	DSP-0231	FRAME BRACKET	
2	DSP-0232	JOINT PIPE	
3	DSP-0233	CORNER PIPE	
4	DSP-0234	PIPE A	
5	DSP-0239	BANNER 4P	
6	DSP-0237	SPRING HOOK	
7	DSP-0238	POLE BRACKET	
8	SLC-0006	FLT WASHER 8.4-25×2	
101	601-7856	HOLDER RING	
201	030-000616-SB	HEX BLT W/S BLK M6×16	
202	060-F00600-0B	FLT WSHR BLK M6	
203	030-000820-SB	HEX BLT W/S BLK M8×20	



① ASSY CCD CAMERA (DSP-0400)

(D-2/2)

ITEM NO.	PART NO.	DESCRIPTION	NOTE
1	DSP-0401	PILLAR BASE	
2	DSP-0402	PILLAR JOINT	
3	DSP-0403	UNIT BASE	
4	DSP-0404	HOLDER BASE	
5	DSP-0405	CAMERA HOLDER	
6	DSP-0406	UNDER COVER	
7	DSP-0407	CAMERA COVER R	
8	DSP-0408	CAMERA COVER L	
9	DSP-0409	ORNAMENT BLOCK	
10	DSP-0410	ORNAMENT PLATE	
11	DSP-0411	CAMERA COVER P	
12	DSP-0412	FRONT COVER	
13	DSP-0413	ACRYL PLATE	
14	VRF-0411	INSULATOR PAPBR	
101	601-7117	CCD CAMERA W/LENS	
201	000-T00406-0B	M SCR TH BLK M4×6	
202	000-T00412-0B	M SCR TH BLK M4×12	
203	000-P00308-W	M SCR PH W/FS M3×8	
204	000-P00408-W	M SCR PH W/FS M4×8	
205	050-F00300	FLG NUT M3	
206	060-F00300	FLT WSHR M3	
301	600-6447-86	WIRE HARN CCD	

⑰ ASSY PTV (DSP-0500)

(D-1/2)

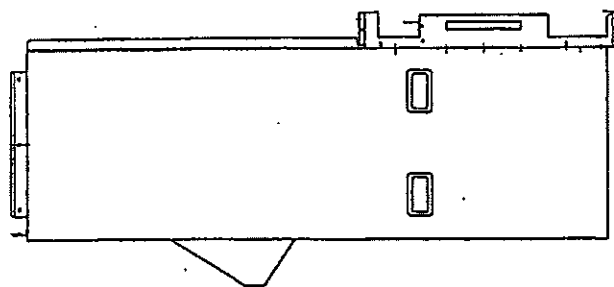
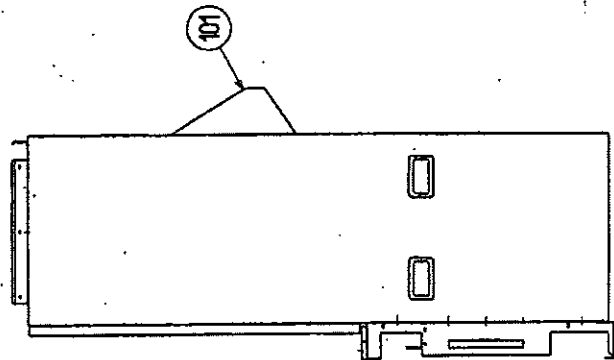
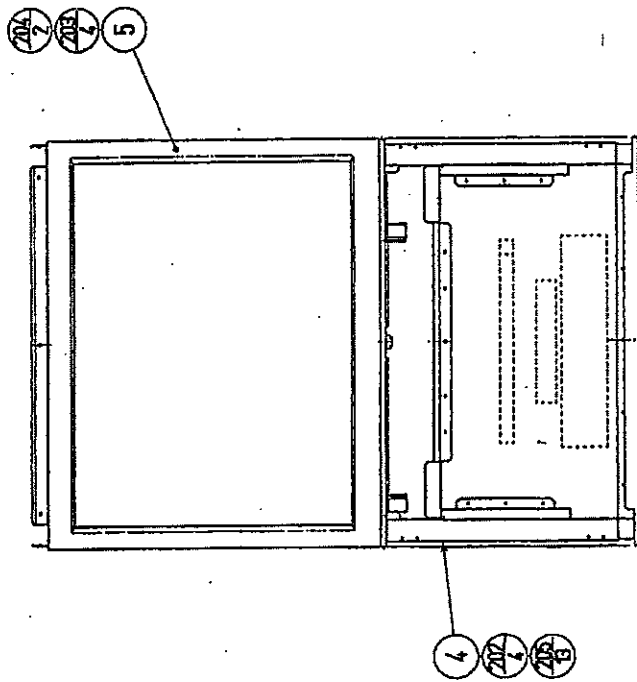
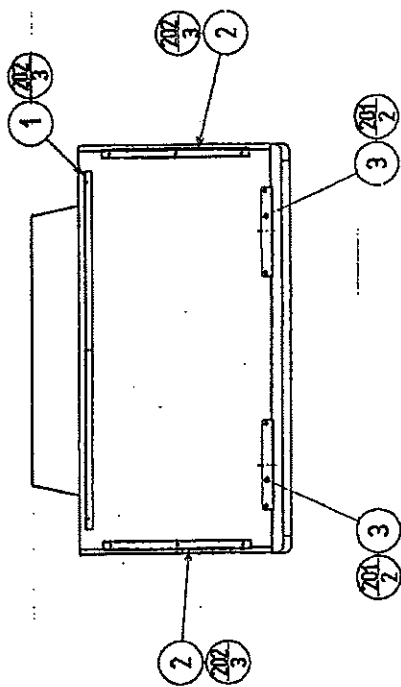

①7 ASSY PTV (DSP-0500)

(D-2/2)

ITEM NO.	PART NO.	DESCRIPTION	NOTE
1	DSP-0501	TOP HOLDER BRKT	
2	DSP-0502	SIDE HOLDER BRKT	
3	DSP-0503	MASK HOLDER	
4	DSP-0550	ASSY JOINT BOX	
5	MGL-1150	ASSY MASK	
101	200-5264 200-5265	PROJECTION DISPLAY 50H 24K PROJECTION DISPLAY 50M 24K	
201	000-F00414	M SCR FH M4×14	
202	000-P00516-W	M SCR PH W/FS M5×16	
203	000-T00520-0B	M SCR TH BLK M5×20	
204	000-T00525-0B	M SCR TH BLK M5×25	
205	011-P03512	TAP SCR PH 3.5×12	
301	600-6447-87	WIRE HARN PTV RGB	
302	600-6447-67	WIRE HARN PTV AC	



⑱ ASSY JOINT BOX (DSP-0550)

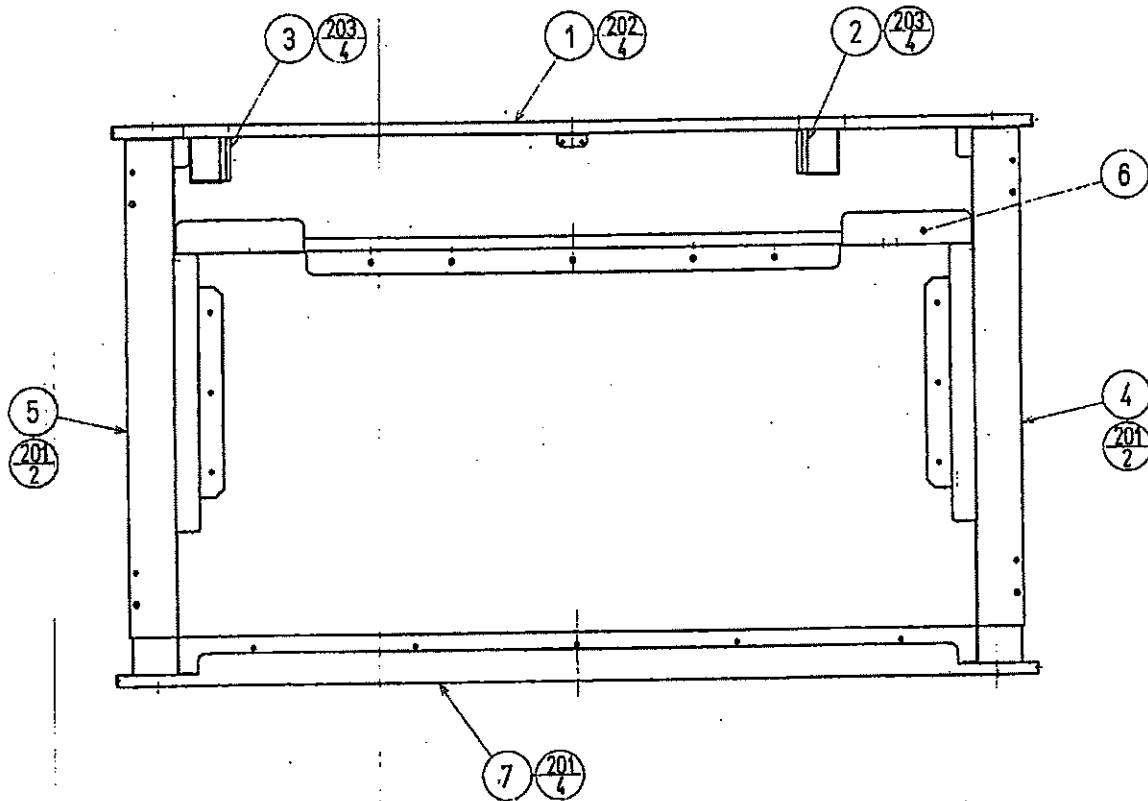

ITEM NO.	PART NO.	DESCRIPTION	NOTE
1	DSP-0551	JOINT BRKT UPPER	
2	DSP-0552	HOOK BRKT R	
3	DSP-0553	HOOK BRKT L	
4	DSP-0554	JOINT BRKT SIDE R	
5	DSP-0555	JOINT BRKT SIDE L	
6	DSP-0556	JOINT BRKT MIDDLE	
7	DSP-0557	JOINT BRKT LOWER	
101	280-5169	CORD CLAMP TL-20S	
201	000-P00408-W	M SCR PH W/PS M4×8	
202	000-T00408-OB	M SCR TH BLK M4×8	
203	050-P00500	FLG-NUT M5	
301	600-6447-84	WIRE HARN EARTH PTV BRKT	

② ASSY BILLBOARD ~ (DSP-0600 ~)

(D-2/2)

Except for Item No. 8, the composition of DSP-0600 ~ parts is in common for all of the Seats. The Part No. of Item No. 8 has the No. of each Seat suffixed, and the description has each Seat's color name suffixed.

EXAMPLE: The part No. of Item No. 8 for Seat No. 1 is referred to as 423-0226-01, and the description as BILLBOARD PLATE RED.

ITEM NO.	PART NO.	DESCRIPTION	NOTE
1	DSP-0601	WOODEN BILLBOARD BOX	
2	DSP-0602	SIDE EDGE COVER	
3	DSP-0603	CORNER EDGE	
4	DSP-0604	NUT PLATE 2-M8	
5	DSP-0605	AC CONNECT PLATE	
6	DYN-2115	NUT PLATE M8	
7	UP-1018	AIR VENT	
8	423-0226~	BILLBOARD PLATE ~	
101	390-5450	XENON FLASH 4.5W	
102	214-0123	BULB SOCKET E-26	
103	390-5538-30SD	ASSY FL30W SD W/CONN HIGH	
104	601-5513	OUTLET AC FASTON 187 TYPE	
105	209-0032	CONN CLOSED END	
106	280-0419	HARNESS LUG	
107	280-5009	CORD CLAMP $\phi$ 21	
108	601-0460	PLASTIC TIE BELT 100MM	
201	000-T00520-0B	M SCR TH BLK M5 $\times$ 20	
202	000-P00420-WB	M SCR PH W/FS BLK M4 $\times$ 20	
203	000-P00425-W	M SCR PH W/FS M4 $\times$ 25	
204	011-P00320	TAP SCR PH 3 $\times$ 20	
205	011-T00312	TAP SCR TH 3 $\times$ 12	
206	011-F00310	TAP SCR FH 3 $\times$ 10	
301	600-6447-68	WIRE HARN BILLBOARD AC	
302	600-6447-69	WIRE HARN EXT BILLBOARD AC	
303	600-6447-70	WIRE HARN FL	
304	600-6447-71	WIRE HARN EXT FLASH	
305	600-6447-72	WIRE HARN EXT FLASH L	
306	600-6447-73	WIRE HARN EXT FLASH R	
307	600-6447-74	WIRE HARN FLASH LAMP	

21 ASSY FRONT CABI ~ (DSP-1000~)

(D-1/2)

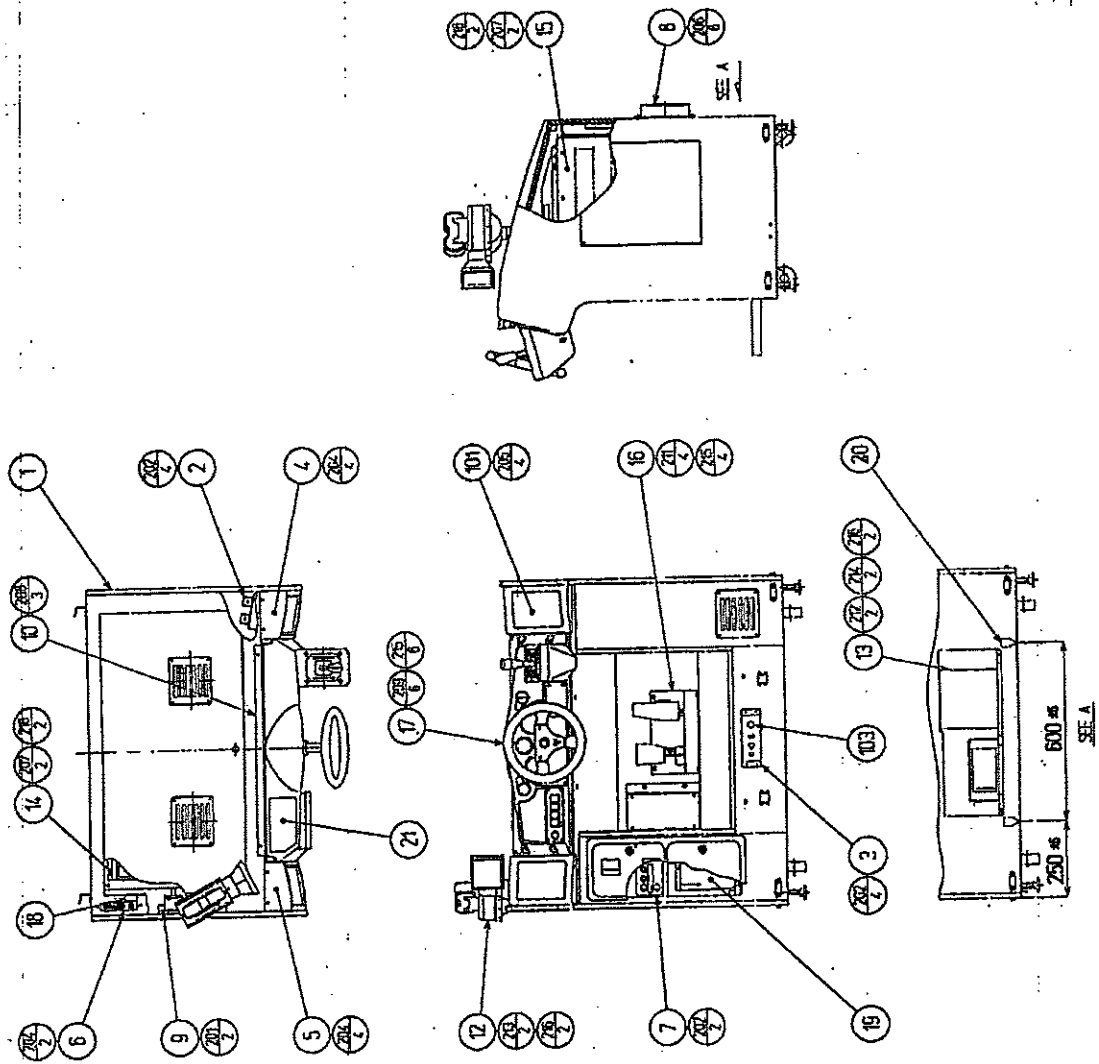

PART No.	DESCRIPTION
DSP-1000-01	ASSY FRONT CAB RED
- 02	BLUE
- 03	YELLOW
- 04	GREEN
- 05	BLACK
- 06	PNK
- 07	SKY BLUE
- 08	ORANGE

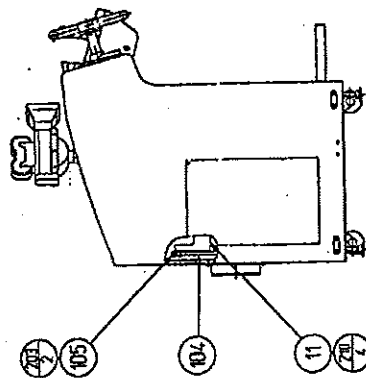

②1 ASSY FRONT CABI ~ (DSP-1000~)

(D-2/2)

Except for Item Nos. 4 and 5, the composition of DSP-1000 ~ parts is in common for all of the Seats. The Part Nos. of Item Nos. 4 and 5 have the applicable No of each Seat suffixed, and the description has each Seat's color name suffixed.

EXAMPLE: The part No of Item No 4 for Seat No. 2 is referred to as DSP-1017-02, and the description as SPEAKER COVER R BLUE.

ITEM NO.	PART NO.	DESCRIPTION	NOTE
1	DSP-1001	ASSY SUB CABI FRONT	
2	DSP-1015	SPEAKER BRKT	
3	DSP-1016	CONN BRKT	
4	DSP-1017~	SPEAKER COVER R ~	
5	DSP-1018~	SPEAKER COVER L ~	
6	DSP-1019	AC UNIT	
7	DSP-1021	SW UNIT	
8	DSP-1022	JOINT BRKT	
9	DSP-1023	ADAPTOR HOLDER	
10	DSP-1024	CONT PNL HOLDER	
11	DSP-1025	AIR JOINT BRKT	
12	DSP-0400	ASSY CCD CAMERA	
13	DSP-4000	ASSY PWR SPLY	
14	DSP-4100	ASSY BLEC	
15	DSP-4200	ASSY SHIELD CASE	
16	DYN-1300	ASSY ACCEL & BRAKE	
17	DYN-12002	ASSY CONT PNL TWIN ENG	
18	421-6526	STICKER ON OFF	
19	253-5366	CASH BOX	
20	421-7020	STICKER CAUTION FORK	
21	422-0503-01	PLAY INSTR SH DSP ENG	
101	130-5096	SPEAKER BOX SERVO	
102	280-0425	CORD CLAMP $\phi$ 10	
103	601-6718	AIR JOINT 10-10 P TYPE	
104	601-6844-81450	AIR TUBE $\phi$ 10-BLACK-1450	
105	601-6935	AIR JOINT 10-10 TU-TYPE	
201	000-P00412-W	M SCR PH W/FS M4×12	
202	000-P00416-W	M SCR PH W/FS M4×16	
203	000-P00425-W	M SCR PH W/FS M4×25	
204	000-T00420-OB	M SCR TH BLK M4×20	
205	000-P00512-W	M SCR PH W/FS M5×12	
206	000-P00520-W	M SCR PH W/FS M5×20	
207	000-P00530-S	M SCR PH W/S M5×30	
208	000-T00520-OB	M SCR TH BLK M5×20	
209	008-B00830-OB	TMP PRF SCR BH BLK M8×30	
210	011-T03512	TAP SCR TH 3.5×12	
211	030-000830-SB	HEX BLT W/S BLK M8×30	
212	032-000530	WING BLT M5×30	
213	050-F00500	FLG NUT M5	
214	060-S00500	SPR WSHR M5	
215	060-F00800-OB	FLT WSHR BLK M8	
216	068-552016	FLT WSHR 5.5-20×1.6	
301	600-6447-56	WIRE HARN SPEAKER L	

22 ASSY SUB CABI FRONT (DSP-1001)

(D-1/3)

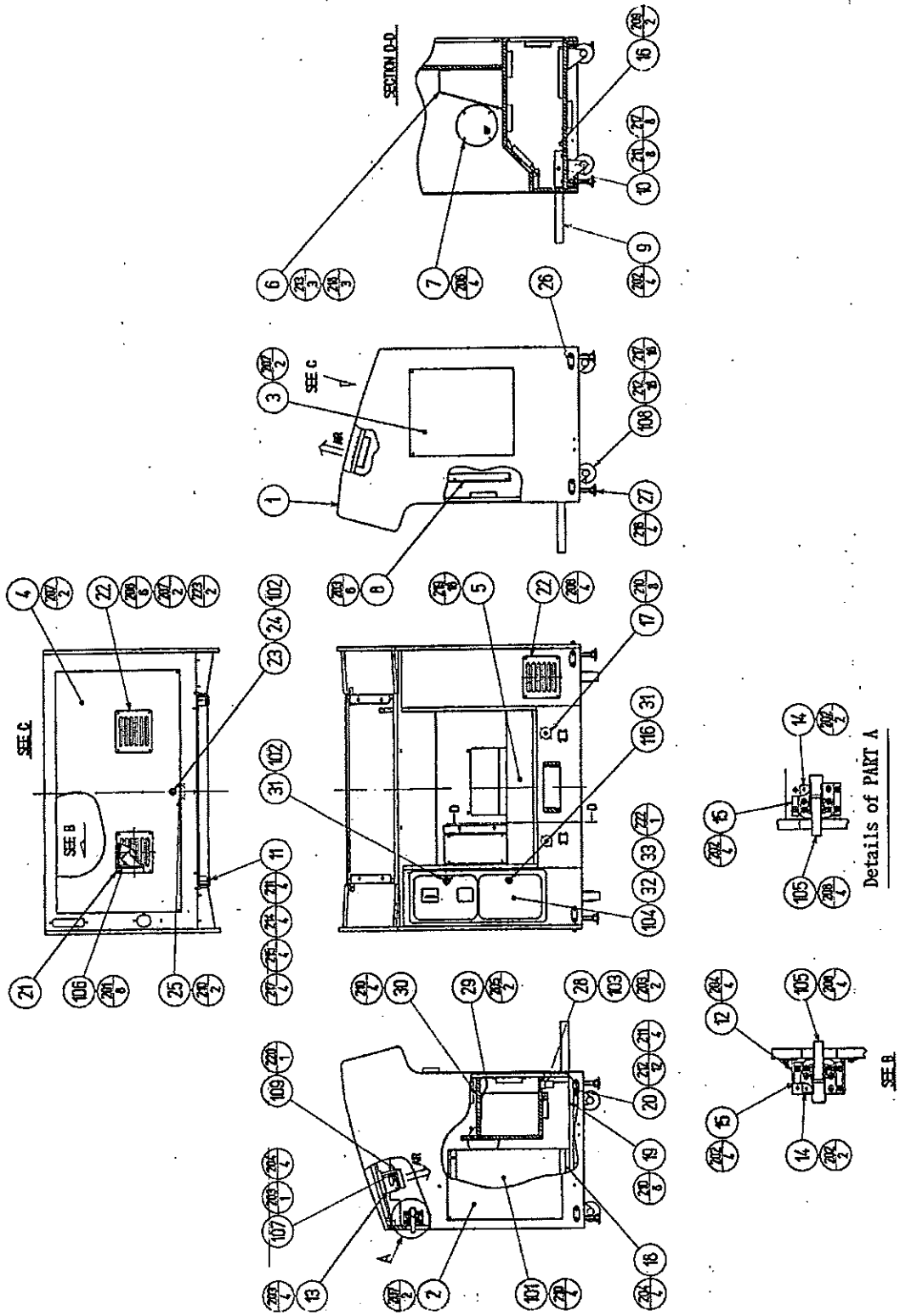

② ASSY SUB CABI FRONT (DSP-1001)

(D-2/4)

ITEM NO.	PART NO.	DESCRIPTION	NOTE
1	DSP-1002	WOODEN FRONT CABINET	
2	DSP-1003	SIDE DOOR A	
3	DSP-1004	SIDE DOOR B	
4	DSP-1005	SERVICE DOOR	
5	DSP-1006	STBP GUARD	
6	DSP-1007	FOOT REST	
7	DSP-1008	GUARD PLATE	
8	DSP-1009	GUIDE PLATE	
9	DSP-1010	JOINT PIPE	
10	DSP-1011	PIPE BRKT	
11	DSP-1012	CONT PNL BRKT	
12	DSP-1013	CLAMP BASE	
13	DSP-1014	MOTOR BRKT	
14	UCQ-1015	ADJUST PLATE	
15	UCQ-1016	ADJUST BRACKET	
16	GPD-1013	STOPPER BRACKET	
17	DYN-2115	NUT PLATE M8	
18	DYN-2208	SPEAKER BRKT	
19	SCR-1008	NUT PLATE FOR CASTER	
20	ARC-1006	LEG BRACKET	
21	HN-1042X	FAN BRKT	
22	UP-1018	AIR VBNT	
23	DP-1148X	LKG TNG	
24	117-0062	PLATE LOCK RETAINER	
25	117-5098	TNG RETAINER PLATE	
26	117-5233	PLATE LEG BRACKET BLACK	
27	601-5699X	LEG ADJUSTER BOLT M16×75	
28	105-5108X	METER BRACKET	
29	105-5169	LOCK BRACKET W	
30	105-5172	CHUTE PLATE DOUBLE	For 220-5128~ only.
	105-5173	CHUTE PLATE MARS	MARS TYPE
31	DP-1167	TNG LKG	
		NOT USED	MARS TYPE
33	421-7501-02	STICKER 6.3V 0.15A	
		NOT USED	MARS TYPE
101	130-5097	SPEAKER BOX SUPER WOOFER	
102	220-5380	MAG LOCK MASTER W/O KEY	
103	220-5412	MAG CNTR W/CONN	
	220-5217	MAG CNTR 6DIG DC12V	MARS TYPE
104	220-5128~	ASSY COIN CHUTE 2DOOR ~	
	220-5374	DOUBLE DOOR FRAME W/CASH DOOR	MARS TYPE
105	250-5011	SUPER CLAMP (TAKIGEN C-137)	
106	260-0011-02	AXIAL FLOW FAN AC100V 50-60Hz	
107	350-5318	SYNCHRONOUS MOTOR 1W (YOKOGAWA SM-C6A1S)	
108	601-6224	CASTER φ 75	
109	260-0037	FAN φ 74 d6	
110	209-0023	CONN CLOSED END	
111	280-0419	HARNESS LUG	
112	280-5008	CORD CLAMP φ 15	
113	280-5009	CORD CLAMP φ 21	
114	601-0460	PLASTIC TIE BELT 100MM	-01 also acceptable.

② ASSY SUB CABI FRONT (DSP-1001)

(D-3/4)

ITEM NO.	PART NO.	DESCRIPTION	NOTE
115	310-5029-F20	SUMITUBE F F20MM	φ 4
116	220-5046-91	MAGNETIC LOCK W/KEYS NOT USED	MARS TYPE
201	000-P00312-W	M SCR PH W/FS M3×12	
202	000-P00408-W	M SCR PH W/FS M4×8	
203	000-P00412-W	M SCR PH W/FS M4×12	
204	000-P00416-W	M SCR PH W/FS M4×16	
205	000-P00420-W	M SCR PH W/FS M4×20	
206	000-T00416-0B	M SCR TH BLK M4×16	
207	000-T00425-0B	M SCR TH BLK M4×25	
208	000-F00408	M SCR FH M4×8	
209	000-P00516-W	M SCR PH W/FS M5×16	
210	011-T00312	TAP SCR TH 3×12	
211	030-000620-S	HEX BLT W/S M6×20	
212	030-000630-SB	HEX BLT W/S BLK M6×30	
213	030-000830-SB	HBX BLT W/S BLK M8×30	
214	031-000625-0B	CRG BLT BLK M6×25	
215	050-F00600	FLG NUT M6	
216	050-H01600	HEX NUT M16	
217	060-F00600	FLT WSHR M6	
218	060-F00800-0B	FLT WSHR BLK M8	
219	079-000008	SCR NAIL THH STNLS 1.5×16	
220	028-C00406-P	SBT SCR CH CUP P M4×6	
221	011-F00312	TAP SCR FH 3×12	
223	050-F00400	FLG NUT M4	
301	600-6447-13	WIRE HARN EXT SOUND VOL	
302	600-6447-14	WIRE HARN EXT VALVE F	
303	600-6447-15	WIRE HARN EXT LEADER LAMP SIG	
304	600-6447-17	WIRE HARN EXT SPEAKBR	
305	600-6447-20	WIRE HARN EXT SOUND BD DC	
306	600-6447-23	WIRE HARN EXT WOOFBR	
307	600-6447-27	WIRE HARN EXT SOUND	
308	600-6447-40	WIRE HARN EXT ACCEL & BRAKE	
309	600-6447-41	WIRE HARN EXT SSR BD DC	
310	600-6447-44	WIRE HARN EXT COIN CHUTE	
311	600-6447-53	WIRE HARN EXT AC FOR BLEC A	
312	600-6447-54	WIRE HARN EXT AC FOR BLEC B	
313	600-6447-58	WIRE HARN WOOFBR	
314	600-6447-59	WIRE HARN EXT MAIN AC	
315	600-6447-78	WIRE HARN BARTH CCD	
316	600-6447-79	WIRE HARN BARTH TO REAR	
317	600-6447-81	WIRE HARN BARTH FLAME	
318	600-6447-82	WIRE HARN BARTH FAN	
319	600-6447-83	WIRE HARN BARTH CASTER L	
320	600-6447-85	WIRE HARN FAN MOTOR	
321	600-6447-88	WIRE HARN BARTH METER	
322	600-6447-89	WIRE HARN BARTH SW UNIT	
323	600-6455-01	WIRE HARN COIN CHUTE DOOR TWIN	For 220-5128~ only.
	600-6455-04	WIRE HARN MARS MS-111	MARS TYPE
324	600-6455-03	WIRE HARN BARTH	

② ASSY SUB CABI FRONT (DSP-1001)

(D-4/4)

ITEM NO.	PART NO.	DESCRIPTION	NOTE
	600-6455-07 HN-1050 109-0045-91 105-5201	WIRE HARN METER GND BK SPACER RING KEY HOLDER MAGNET LOCK BRKT FOR ASAHI	} For 220-5128~ only.
	600-6455-06	WIRE HARN METER GND WH	MARS TYPE



②③ AC UNIT (DSP-1019)

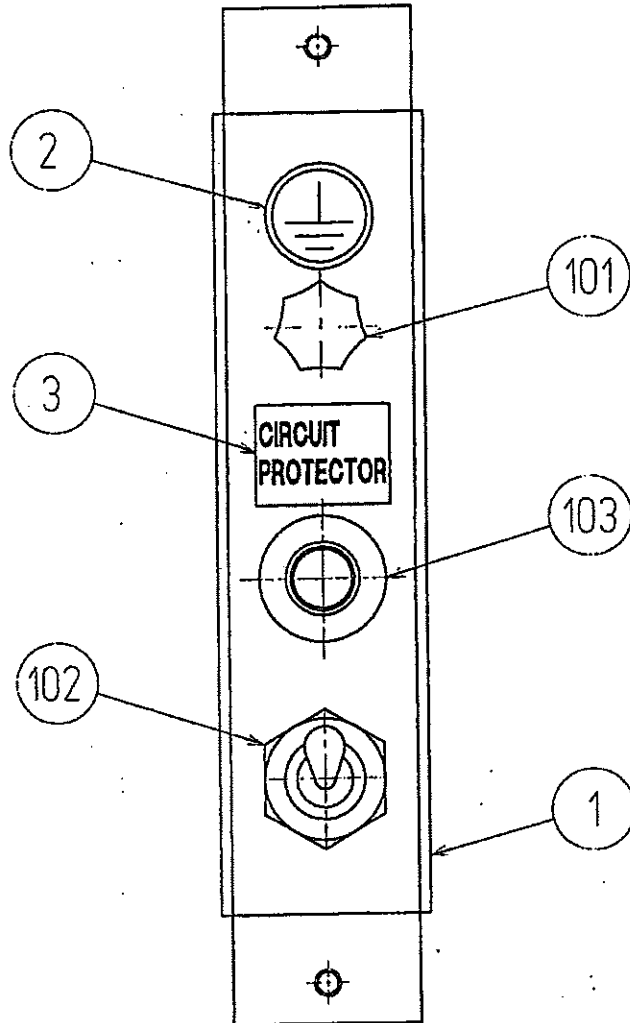

ITEM NO.	PART NO.	DESCRIPTION	NOTE
1	DSP-1020	AC BRKT	
2	421-8202	STICKER EARTH MARK	
3	421-7468-01	STICKBR C. P. W/PIC	
101	280-0417	TERMINAL BINDING POST BLACK	
102	509-5234	SW TOGGLE 25A	
103	512-5033-10000	CIRCUIT PROTECTOR 10000mA	
104	310-5029-F20	SUMITUBE F F20MM	
105	601-0460	PLASTIC TIE BELT 100MM	
301	600-6447-02	WIRE HARN MAIN SW	
302	600-6447-03	WIRE HARN C. P.	
303	600-6447-75	WIRE HARN EARTH AC UNIT 1P	
304	600-6447-76	WIRE HARN EARTH AC UNIT 3P	
305	600-6447-77	WIRE HARN EARTH AC UNIT 6P	

②④ SW UNIT (DSP-1021)

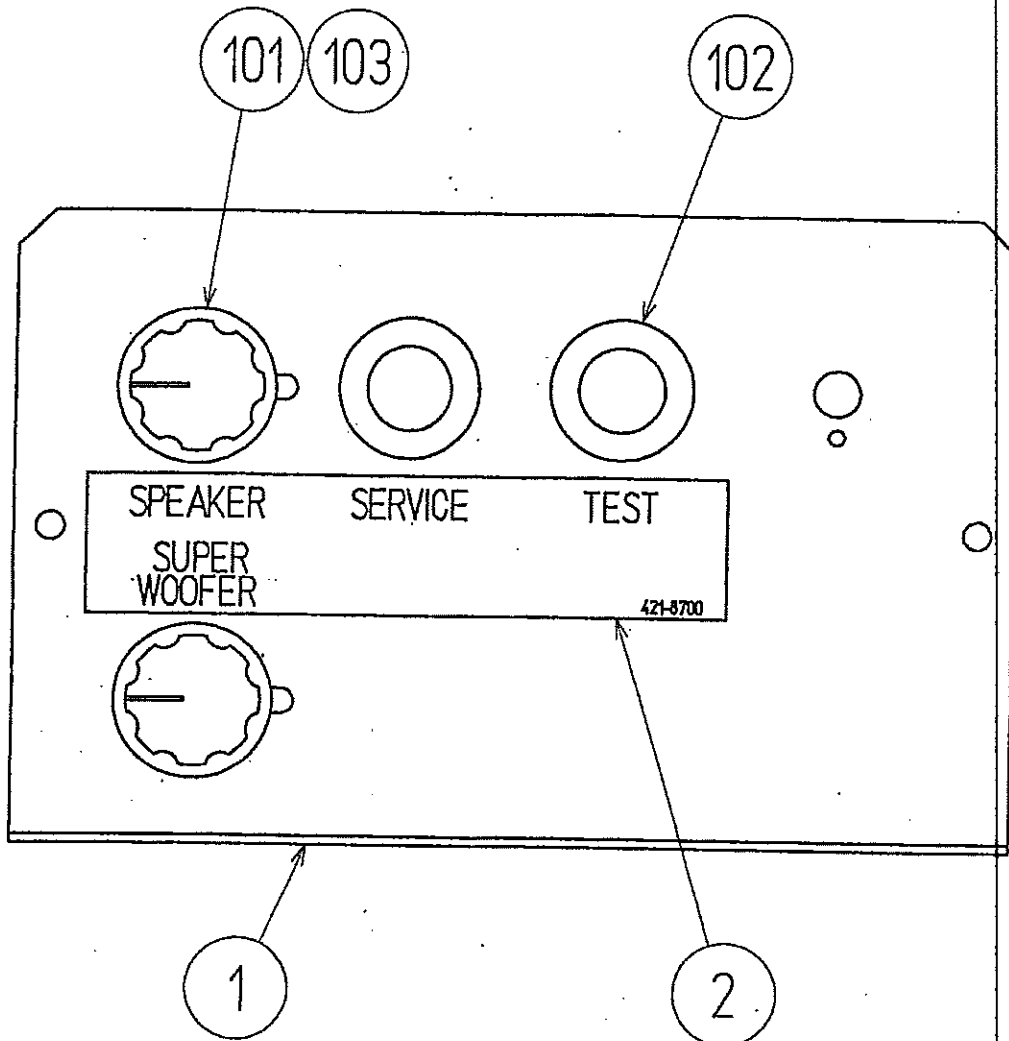

ITEM NO.	PART NO.	DESCRIPTION	NOTE
1	BVN-1024	SWICH BRACKET	
2	421-8700	STICKER SW UNIT DSP	
101	220-5179	VOL CONT B-5K OHM	
102	509-5028	SW PB 1M	
103	601-0042	KNOB 22MM	
104	310-5029-F20	SUMITUBE F F20MM	φ 4
105	601-0460	PLASTIC TIE BELT 100MM	
301	600-6363-70	WIRE HARN SOUND VOL	
302	600-6447-90	WIRE HARN SW UNIT	

②⑤ | ASSY CONT PNL TWIN (DYN-12002)

(0-1/2)

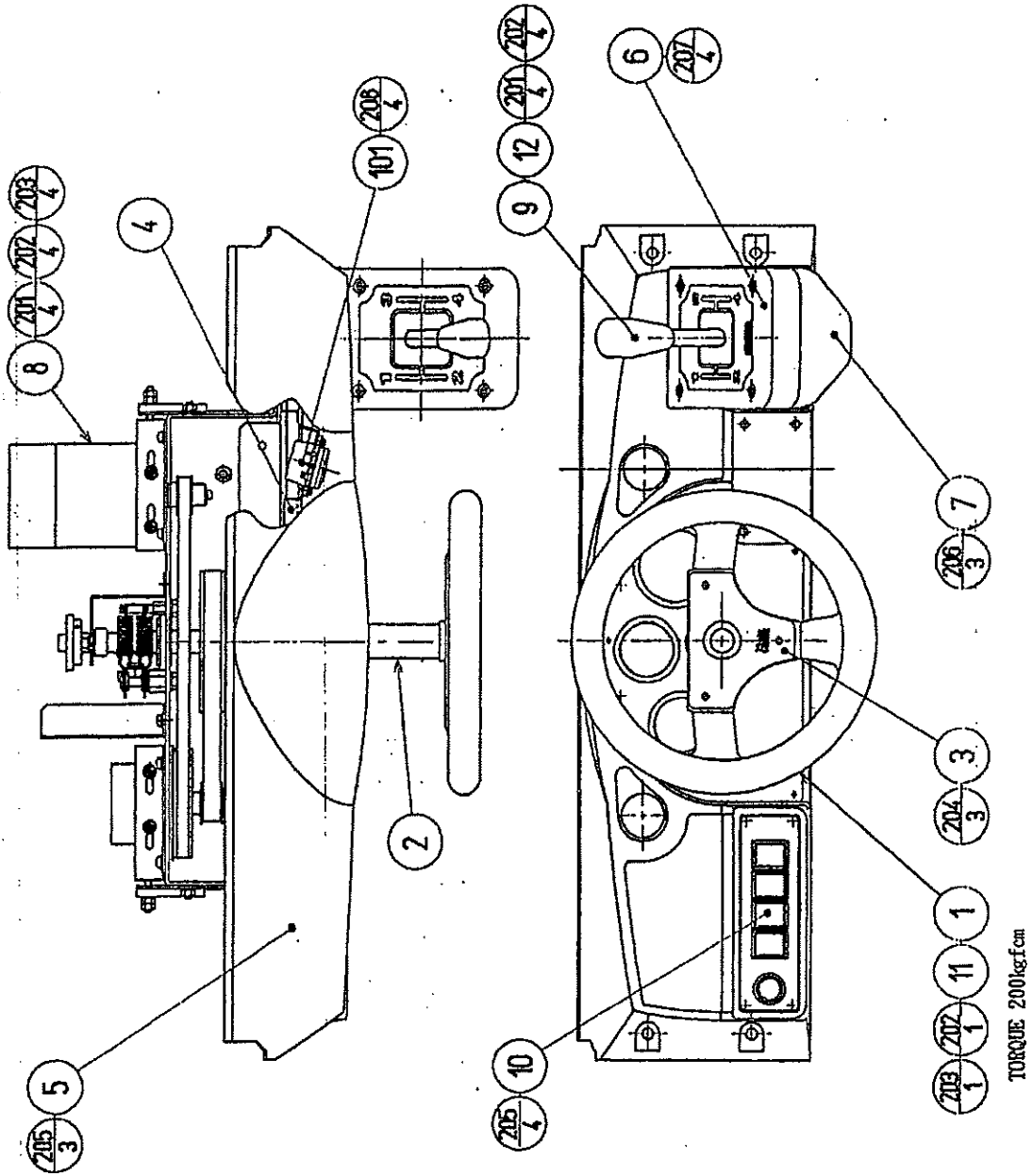

②5 ASSY CONT PNL TWIN (DYN-12002)

①-2/2)

ITEM NO.	PART NO.	DESCRIPTION	NOTE
1	DYN-1201	STEBRING WHEEL	
2	DYN-1209	HANDLE COLLAR	
3	DYN-1210	STEBRING EMBLEM	
4	DYN-1212	CONTROL PANEL BRKT TWIN	
5	DYN-1214-01	CONTROL PANEL COVER ENG	
6	DYN-1222	SHIFT COVER A	
7	DYN-1223	SHIFT COVER B	
8	DYN-1250	ASSY HANDLE MECHA	
9	DYN-2150Y	ASSY 4 SPEED SHIFTER	
10	DYN-1290	ASSY VIRTUAL BUTTON TWIN	
11	OUT-2026	SPACER	
12	DYN-1224	SPL BLT M8	
101	180-5112	TWEETER 80HM 2W $\phi$ 35	
102	601-0460	PLASTIC TIE BELT 100MM	
103	280-5009	CORD CLAMP $\phi$ 21	-01 also acceptable
104	280-0419	HARNBSS LUG	
201	060-F00800	FLT WSHR M8	
202	060-S00800	SPR WSHR M8	
203	050-H00800	HEX NUT M8	
204	008-T00508-0C	TMP PRF SCR TH CRM M5 $\times$ 8	
205	000-T00416-0C	M SCR TH CRM M4 $\times$ 16	
206	000-P00412-W	M SCR PH W/FS M4 $\times$ 12	
207	000-T00412-0B	M SCR TH BLK M4 $\times$ 12	
208	000-P00308-W	M SCR PH W/FS M3 $\times$ 8	
301	600-6373-33	WIRE HARN EXT TWEETER	
302	600-6373-45	WIRE HARN EXT SHIFT	
303	600-6373-46	WIRE HARN VIRTUAL BUTTON	

②⑥ ASSY HANDLE MECHA (DYN-1250)

(D-1/3)

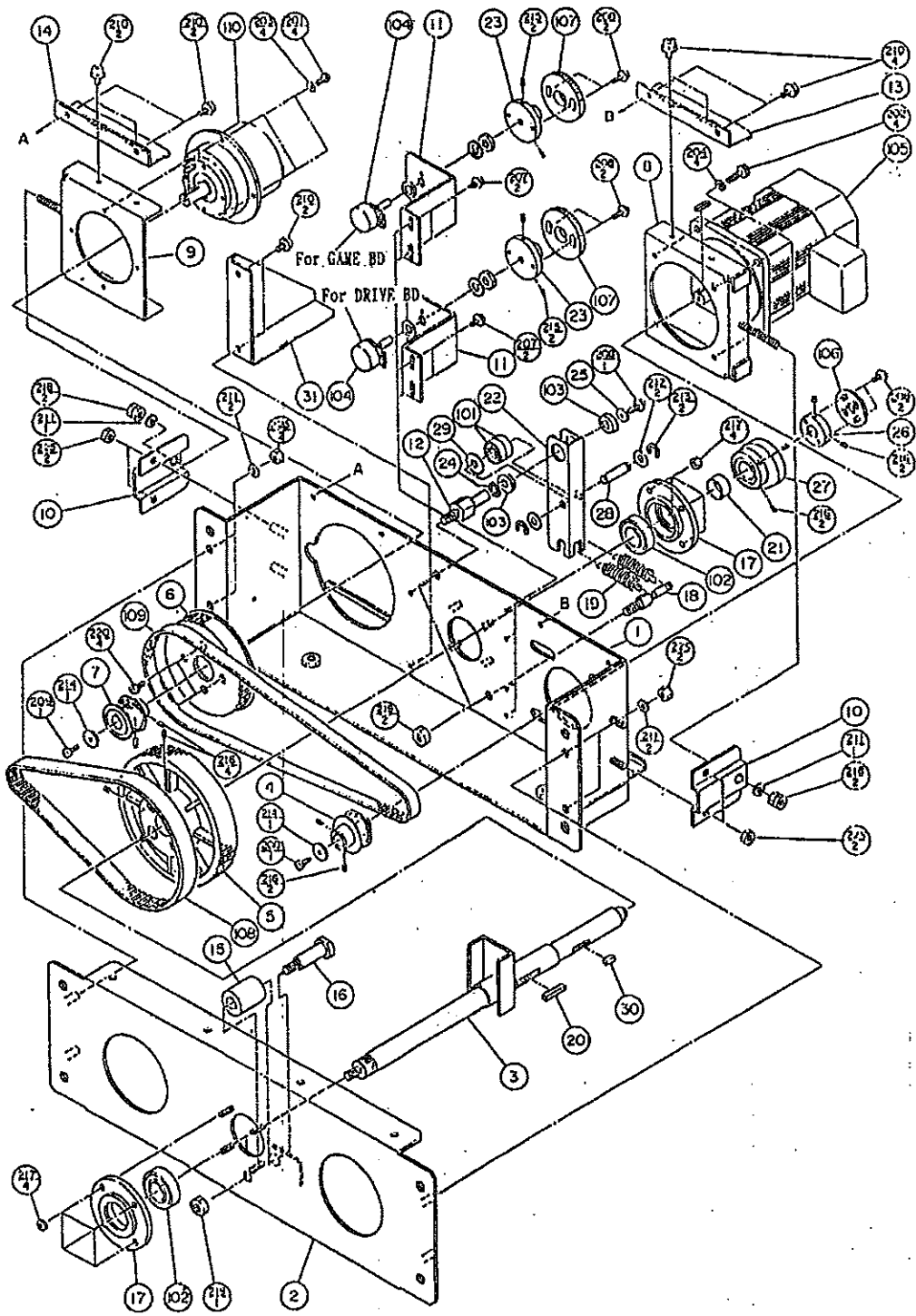

②⑥ ASSY HANDLE MECHA (DYN-1250)

(D-2/3)

ITEM NO.	PART NO.	DESCRIPTION	NOTE
1	DYN-1251	HANDLE BASE	
2	DYN-1252	BASE LID	
3	DYN-1253	HANDLE SHAFT	
4	DYN-1254	DRIVE PULLEY	
5	DYN-1255	HANDLE PULLEY	
6	DYN-1256	CLUTCH PULLEY A	
7	DYN-1257	CLUTCH PULLEY B	
8	DYN-1258	MOTOR BRACKET	
9	DYN-1259	CLUTCH BRACKET	
10	DYN-1260	TENSIONER BRACKET	
11	DYN-1261	VR BRACKET	
12	DYN-1262	SWING ARM SHAFT	
13	DYN-1263	GUIDE HOLDER A	
14	DYN-1264	GUIDE HOLDER B	
15	DYN-1265	STOPPER RUBBER	
16	DYN-1266	STOPPER BOLT	
17	DYN-1267	HOUSING	
18	DYN-1268	SPRING HOOK	
19	DYN-1269	EXT SPRING	
20	DYN-1270	STOPPER KEY	
21	DYN-1272	SPACER RING	
22	DYN-1273	SWING ARM	
23	BVG-1221	GEAR HOLDER	
24	BVG-1340	FLT WSHR 8.1-12×2	
25	BVG-1341	FLT WSHR 4.1-12×2	
26	SLC-1130	ADJUST RING	
27	SLC-1141X	WHITE CAM	
28	SOR-2112	BEARING SHAFT	
29	SOR-2113	SPACER	
30	SOR-2115	KEY 5×10	
31	DYN-1274	GUARD BRKT	
101	100-5018	BALL BEARING φ8 (NSK 608ZZ)	
102	100-5112	BBEARING φ17 (NSK 6003ZZ)	
103	100-5041	BBEARING (NSK F688ZZ)	
104	220-5373	VOL CONT B-5K OHM	
104	220-5484	VOL CONT B-5K OHM	
105	350-5235	MOTOR AC100V 1250/1550rpm W/H	
105	350-5294	MOTOR AC100V 60W	
106	601-6172	GEAR 48	
107	601-6959	GEAR 64	
108	601-7487	TIMING BELT (150 5M 550)	
109	601-7488	TIMING BELT (100 5M 750)	
110	601-7489	PARTICLE CLUTCH BRAKE	
111	310-5029-F20	SUMITUBE F F20MM	
112	601-0460	PLASTIC TIE BELT 100mm	
114	209-0023	CONN CLOSED END	SMALL TYPE
201	020-000410-HZ	HEX SKT CAP SCR BLK OZ M4×10	
202	020-000512-HZ	HEX SKT CAP SCR BLK OZ M5×12	
203	060-S00400	SPR WSHR M4	
204	060-S00500	SPR WSHR M5	

② ASSY HANDLE MECHA: (DYN-1250)

(D-3/3)

ITBM NO.	PART NO.	DESCRIPTION	NOTE
207	000-P00408-W	M SCR PH W/FS M4×8	
208	000-P00412-W	M SCR PH W/FS M4×12	
209	000-P00416-S	M SCR PH W/S M4×16	
210	000-P00508-W	M SCR PH W/FS M5×8	
211	060-F00600	FLT WSHR M6	
212	060-F00800	FLT WSHR M8	
213	065-B00700	B RING 7MM	
214	068-441616	FLT WSHR 4.4-16×1.6	
215	028-A00308-P	SBT SCR HEX SKT CUP P M3×8	
216	028-A00408-P	SBT SCR HEX SKT CUP P M4×8	
217	050-U00500	U NUT M5	
218	050-H00600	HEX NUT M6	
219	050-U00800	U NUT M8	
220	000-P00408-S	M SCR PH W/S M4×8	
221	000-P00310	M SCR PH M3×10	
222	060-F00300	FLT WSHR M3	
223	060-S00300	SPR WSHR M3	
225	050-U00600	U NUT M6	
301	600-6363-64	WIRE HARN HANDLE MECHA	
302	600-6363-65	WIRE HARN STBERING	
303	600-6363-85	WIRE HARN BARTH HANDLE MECHA	

②⑦ ASSY VIRTUAL BUTTON TWIN (DYN-1290)

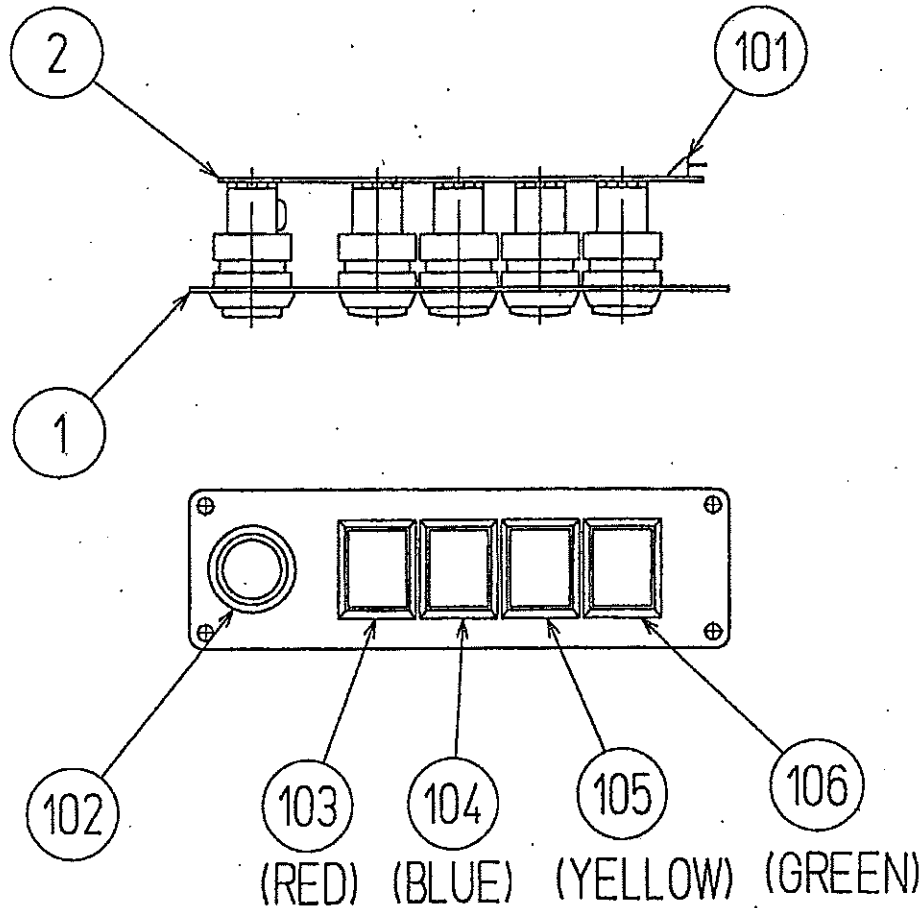

ITBM NO.	PART NO.	DESCRIPTION	NOTE
1	DYN-1291	VR BUTTON BRKT	
2	171-6478B	PC BD LIGHTING SW×5	
101	212-5205-12	CONN JST M 12P RTA	
102	509-5560-Y	PB SW W/L 6V 1L Y	YELLOW
103	509-5561-R	PB SW W/L 6V 5L R	RED
104	509-5561-S	PB SW W/L 6V 5L S	BLUE
105	509-5561-Y	PB SW W/L 6V 5L Y	YELLOW
106	509-5561-G	PB SW W/L 6V 5L G	GREEN



28 ASSY 4 SPEED SHIFTER (DYN-2150Y)

(D-1/2)

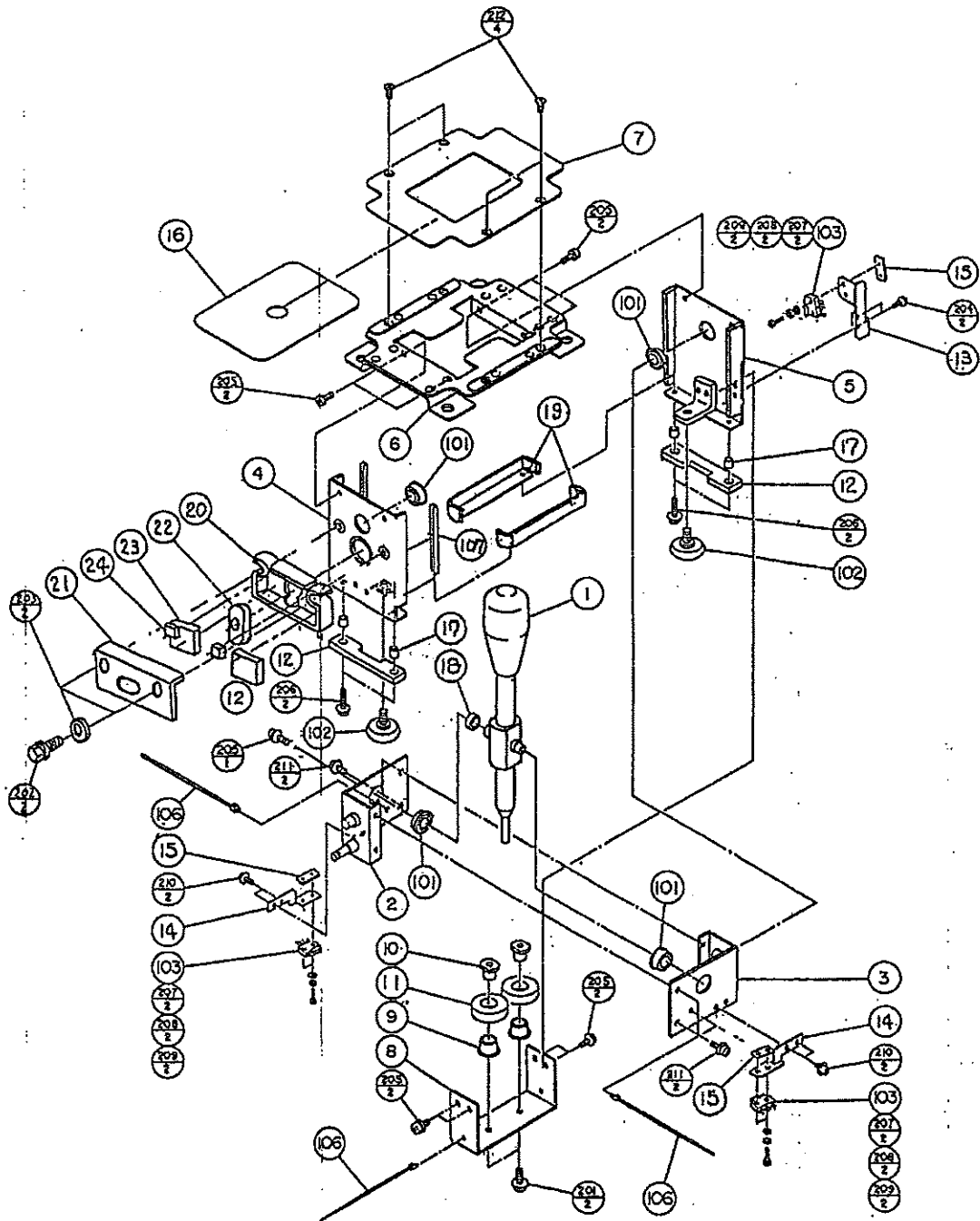

②8 ASSY 4 SPEED SHIFTER (DYN-2150Y)

(D-2/2)

ITEM NO.	PART NO.	DESCRIPTION	NOTE
1	DYN-2151Y	SHIFT KNOB	
2	DYN-2152	SHAFT CASE FRONT	
3	DYN-2153	SHAFT CASE REAR.	
4	DYN-2154X	FRONT BASE	
5	DYN-2155X	REAR BASE	
6	DYN-2156	UPPER BASE	
7	DYN-2157	UPPER COVER	
8	DYN-2158X	ROLLER BRKT	
9	DYN-2159	COLLAR $\phi$ 10	
10	DYN-2160	ROLLER SHAFT	
11	DYN-2163	RUBBER RING 80	
12	DYN-2164X	RUBBER STOPPER	
13	DYN-2165	SW BRKT A	
14	DYN-2166	SW BRKT B	
15	DYN-2167	NUT PLATE M2	
16	DYN-2169X	SLIDE PLATE	
17	DYN-2170	COLLAR $\phi$ 4	
18	DYN-2171	COLLAR $\phi$ 8	
19	DYN-2172X	BOTTOM PLATE	
20	DYN-2174	RUBBER CASE	
21	DYN-2175	RUBBER CASE LID	
22	DYN-2176	CENTERING BLOCK	
23	DYN-2177	RUBBER BLOCK L	
24	DYN-2178	RUBBER BLOCK S	
101	100-5041	BEARING (NSK F688ZZ)	
102	100-5176	DERURIN BEARING $\phi$ 26	
103	509-5566	SW MICRO TYPE (OMRON SS-5GLT)	
104	601-0460	PLASTIC TIB BELT 100MM	
105	280-5009	CORD CLAMP $\phi$ 21	-01 also acceptable.
106	280-5251	SELF MOUNT TIE 2.5	
107	601-6231-D070	BDGING NEW TYPE	
201	000-P00514-W	M SCR PH W/PS M5 $\times$ 14	
202	030-000620-S	HEX BLT W/S M6 $\times$ 20	
203	060-F00600	FLT WSHR M6	
204	000-P00308-W	M SCR PH W/PS M3 $\times$ 8	
205	000-P00412-W	M SCR PH W/PS M4 $\times$ 12	
206	000-P00416-W	M SCR PH W/PS M4 $\times$ 16	
207	000-P00212	M SCR PH M2 $\times$ 12	
208	060-F00200	FLT WSHR M2	
209	060-S00200	SPR WSHR M2	
210	010-P00306-F	S-TITE SCR PH W/F M3 $\times$ 6	
211	010-P00408-F	S-TITE SCR PH W/F M4 $\times$ 8	
212	000-F00408	M SCR PH M4 $\times$ 8	
301	600-6363-75	WIRE HARN SHIFT MECHA	
302	600-6363-89	WIRE HANR EARTH SHIFT MECHA	

29 ASSY ACCEL & BRAKE (DYN-1300)

(D-1/2)

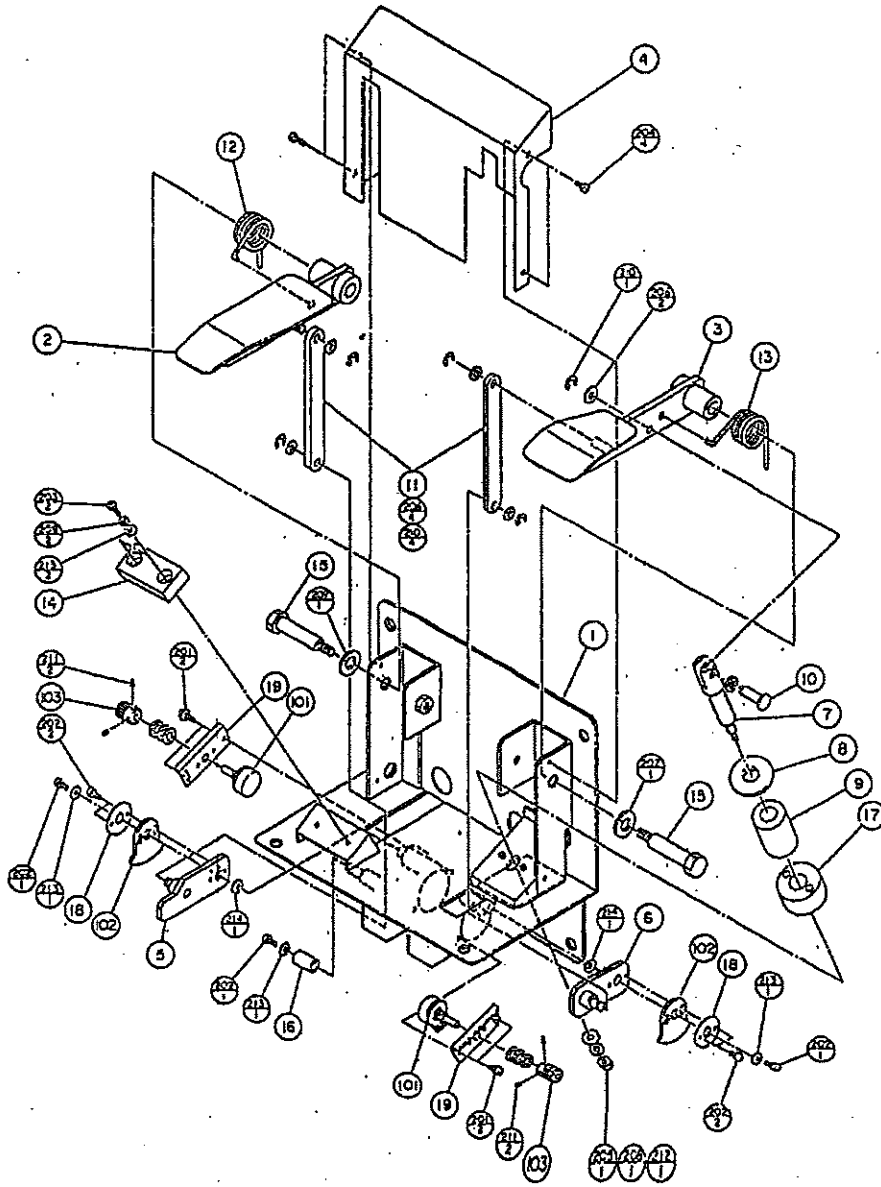

② ASSY ACCEL & BRAKE (DYN-1300)

(D-2/2)

ITEM NO.	PART NO.	DESCRIPTION	NOTE
1	DYN-1301	PEDAL BASE	
2	BVG-1402	ACCEL PEDAL	
2	DYN-1306	ACCEL PEDAL AL	
3	BVG-1403	BRAKE PEDAL	
3	DYN-1307	BRAKE PEDAL AL	
4	BVG-1404	PEDAL COVER	
5	BVG-1405	SWING ARM A	
6	BVG-1406	SWING ARM B	
7	BVG-1407	PUSH ROD	
8	BVG-1408	PUSH PLATE	
9	DYN-1302	RUBBER DUMPER	
10	BVG-1410	PUSH ROD PIN	
11	BVG-1411	LINK ROD	
12	DYN-1303	TORSION SPRING ACCEL	
13	BVG-1413	TORSION SPRING B	
14	BVG-1414	RUBBER STOPPER	
15	BVG-1415	PEDAL SHAFT	
16	BVG-1416	SWING ARM STOPPER	
17	BVG-1417	SPACER	
18	GLC-2122	GEAR PLATE	
19	RDM-1210	VR BRACKET	
101	220-5373	VOL CONT B-5K OHM	
101	220-5484	VOL CONT B-5K OHM	
102	601-6005	ADJUST GEAR	
103	601-5943	GEAR 20 $\phi$ 15	
104	310-5029-F20	SUMITUBE F F20MM	$\phi$ 4
105	601-0460	PLASTIC TIE BELT 100mm	
106	280-5009	CORD CLAMP $\phi$ 21	-01 also acceptable.
201	000-P00408-W	M SCR PH W/FS M4 $\times$ 8	
202	000-P00408-S	M SCR PH W/S M4 $\times$ 8	
203	000-P00416-OB	M SCR PH BLK M4 $\times$ 16	
204	008-T00408-OB	TMP PRF SCR TH BLK M4 $\times$ 8	
205	050-H00600	HEX NUT M6	
206	060-F00800-OB	FLT WSHR BLK M8	
207	060-S01200-OB	SPR WSHR BLK M12	
208	060-S00600	SPR WSHR M6	
209	060-S00400-OB	SPR WSHR BLK M4	
210	065-B00600	E RING 6MM	
211	028-A00308-P	SET SCR HEX SKT CUP P M3 $\times$ 8	
212	068-652016	FLT WSHR 6.5-20 $\times$ 1.6	
213	DYN-1304	FLT WSHR BLK 4.4-12 $\times$ 1.6	
214	DYN-1305	FLT WSHR 12.2-22 $\times$ 0.5	
301	600-6178-54	WIRE HARN ACCEL & BRAKE	
302	600-6178-113	WIRE HARN EARTH ACCEL & BRAKE	

③⑩ ASSY REAR CABI ~ (DSP-2000 ~)

(D-1/2)

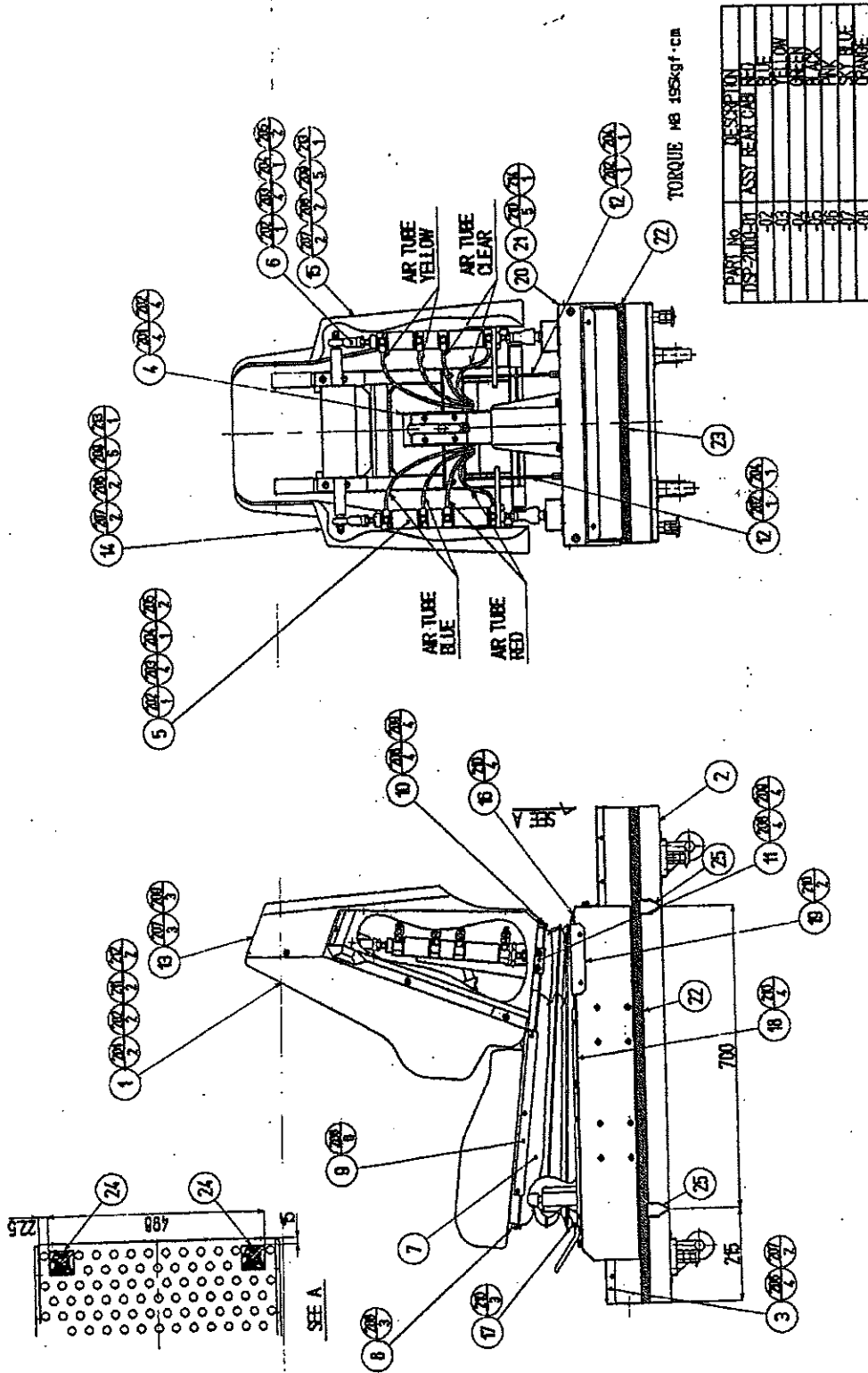

③⑩ ASSY REAR CABI ~ (DSP-2000 ~)

①-2/2)

Except for Item Nos. 13, 22 and 23, the composition of DSP-2000 ~ parts is in common for all of the Seats. The Part Nos. of Item Nos. 13, 22 and 23 have the applicable No of each Seat suffixed, and the description has each Seat's color name suffixed.  
 EXAMPLE: The part No of Item No. 13 for Seat No. 3 is referred to as DSP-2007-03, and the description as SEAT BACK COVER YBLOW.

ITEM NO.	PART NO.	DESCRIPTION	NOTE
1	DSP-2100	ASSY SEAT	
2	DSP-2200	ASSY REAR BASE	
3	DSP-2300	ASSY BASE LID F	
4	DSP-2400	ASSY GUIDE BRKT	
5	DSP-2500	ASSY AIR CYLINDER L	
6	DSP-2600	ASSY AIR CYLINDER R	
7	DSP-2001	BELLOWS	
8	DSP-2002	BELLOWS STOPPER A	
9	DSP-2003	BELLOWS STOPPER B	
10	DSP-2004	BELLOWS STOPPER C	
11	DSP-2005	BELLOWS STOPPER D	
12	DSP-2006	STOPPER BAR	
13	DSP-2007~	SEAT BACK COVER ~	
14	DSP-2008	SEAT BACK COVER L	
15	DSP-2009	SEAT BACK COVER R	
16	DSP-2010	BELLOWS HOLDER B	
17	DSP-2011	BELLOWS HOLDER F	
18	DSP-2012	BELLOWS HOLDER L	
19	DSP-2013	BELLOWS HOLDER LB	
20	DSP-2014	BELLOWS HOLDER R	
21	DSP-2015	BELLOWS HOLDER RB	
22	DSP-2016~	STICKER LINE L~	
23	DSP-2017~	STICKER LINE S~	
24	421-7010	STICKER CAUTION	
25	421-7020	STICKER FORK	
201	030-000816-SB	HEX BLT W/S BLK M8×16	
202	060-F00800-OB	FLT WSHR BLK M8	
203	000-P00516-W	M SCR PH W/FS M5×16	
204	060-S00800-OB	SPR WSHR BLK M8	
205	050-H00800-OB	HEX NUT BLK M8	
206	060-F00410-OB	M SCR PH BLK M4×10	
207	000-T00412-OB	M SCR TH BLK M4×12	
208	000-T00420-OB	M SCR TH BLK M4×20	
209	068-441616-OB	FLT WSHR BLK 4.4-16×1.6	
210	000-P00412-WB	M SCR PH W/FS BLK M4×12	
211	030-000616-SB	HEX BLT W/S BLK M6×16	
212	060-F00600-OB	FLT WSHR BLK M6	
213	000-T00430-OB	M SCR TH BLK M4×30	
214	000-P00408-WB	M SCR PH W/FS BLK M4×8	

③① ASSY SEAT (DSP-2100)

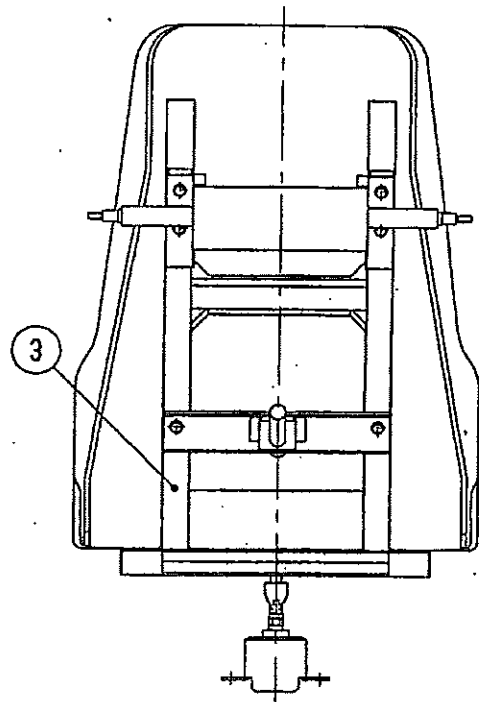
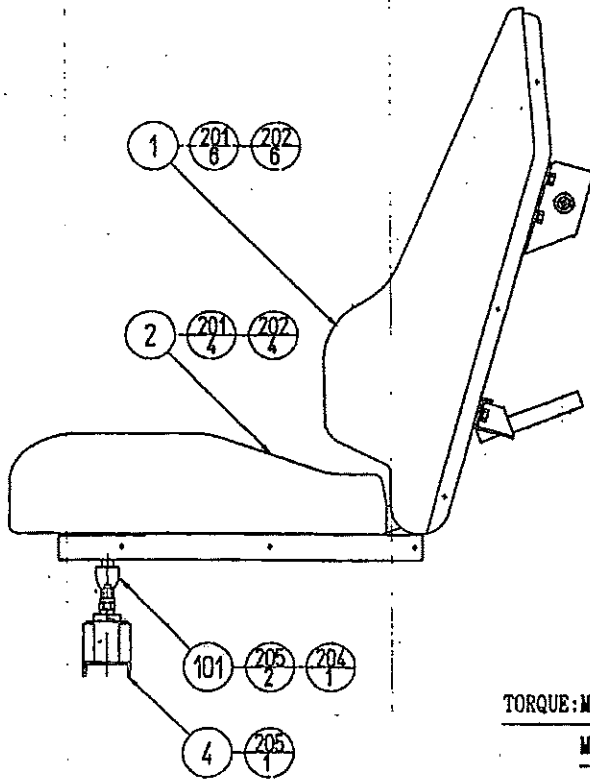

TORQUE: M8: 150kg · cm

M10: 270kg · cm

ITBM NO.	PART NO.	DESCRIPTION	NOTE
1	DYN-2131	UPPER SEAT	
2	DYN-2132	LOWER SEAT	
3	DSP-2101	SEAT FRAME	
4	DSP-2102X	PIVOT BASE	
101	111-0013	LINK BALL 10	
201	030-000850-SB	HEX BLT W/S BLK M8 × 50	
202	060-F00800-0B	FLT WSHR BLK M8	
204	060-F01000	FLT WSHR M10	
205	050-H01000	HEX NUT M10	

③② ASSY REAR BASE (DSP-2200)

(D-1/2)

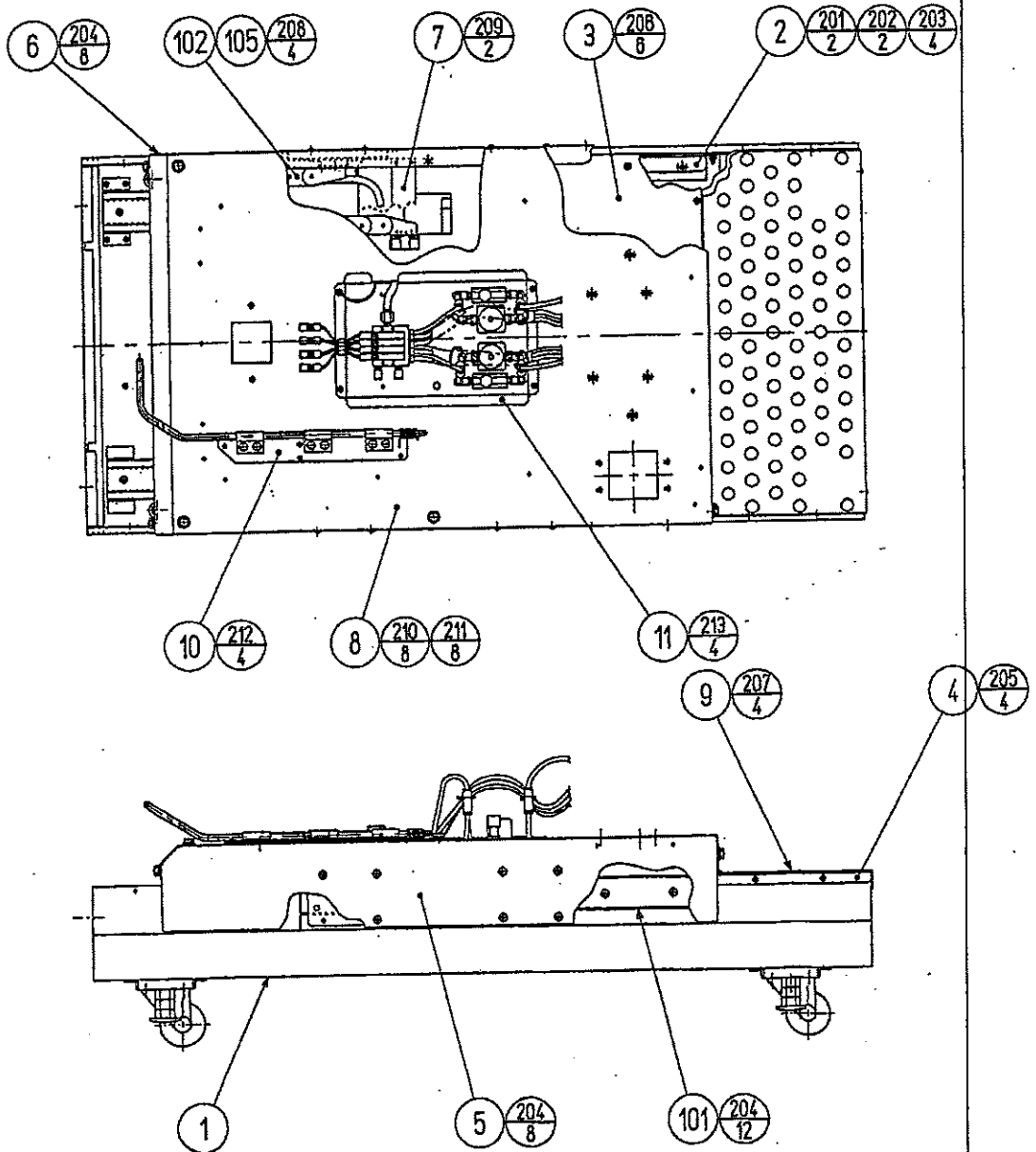



③2 ASSY REAR BASE (DSP-2200)

(D-2/2)

ITEM NO.	PART NO.	DESCRIPTION	NOTE
1	DSP-2201	REAR BASE	
2	DSP-2202	RAIL HOLDER	
3	DSP-2203	BASE LID CTR	
4	DSP-2204	BASE LID R	
5	5750 DSP-2205X	CARRIER MOUNT BRKT L	
6	5751 DSP-2206X	CARRIER MOUNT BRKT R	
7	DSP-2207	WIRE SUPPORT	
8	DSP-2208X	SEAT CARRIER	
9	DSP-2209	LID COVER	
10	DSP-2220	ASSY LOCK ARM	
11	DSP-2250	ASSY AIR VALVE	
101	100-5184	SLIDE PACK L=600	
102	601-6981-010	CABLE BBAR L=10	
103	280-5169	CORD CLAMP TL-20S	
104	601-0460	PLASTIC TIE BELT 100MM	
105	601-6844-01550	AIR TUBE $\phi$ 10-CLEAR-1550	
201	030-000840-S	HEX BLT W/S M8 $\times$ 40	
202	050-H00800	HEX NUT M8	
203	050-F00600	FLG NUT M6	
204	000-T00512-OB	M SCR TH BLK M5 $\times$ 12	
205	000-F00410-OB	M SCR PH BLK M4 $\times$ 10	
206	000-T00408-OB	M SCR TH BLK M4 $\times$ 8	
207	000-T00408-OC	M SCR TH CRM M4 $\times$ 8	
208	000-P00516-W	M SCR PH W/FS M5 $\times$ 16	
209	050-F00400	FLG NUT M4	
210	030-000816-SB	HEX BLT W/S BLK M8 $\times$ 16	
211	060-F00800-OB	PLT WSHR BLK M8	
212	000-P00508-W	M SCR PH W/FS M5 $\times$ 8	
213	000-P00412-WB	M SCR PH W/FS BLK M4 $\times$ 12	
301	600-6447-60	WIRE HARN EXT VALVE R	
302	600-6447-80	WIRE HARN BARTH REAR CABI	

③③ REAR BASE (DSP-2201)

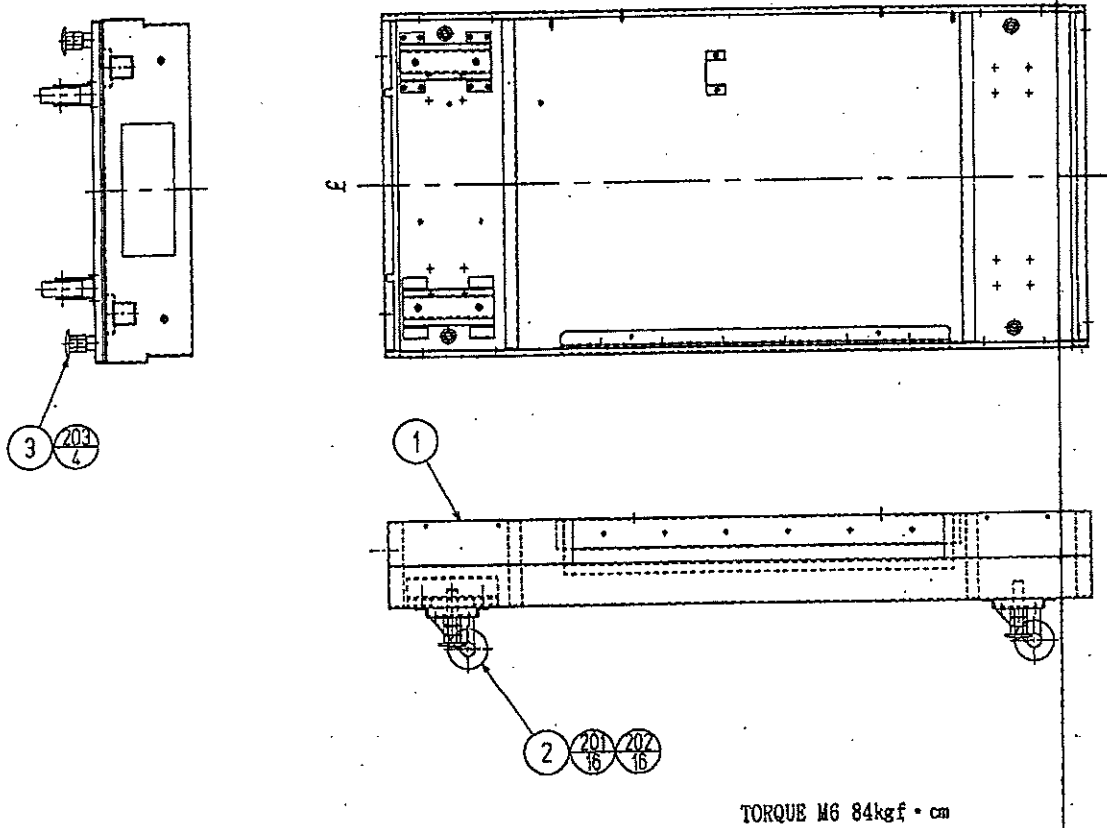

ITEM NO.	PART NO.	DESCRIPTION	NOTE
1	DSP-2201-A	REAR BASE BLANK	
2	601-5471	CASTER	
3	601-5699X	LEG ADJUSTER BOLT M16×75	
201	030-000616-S	HEX BLT W/S M6×16	
202	060-F00600	FLT WSHR M6	
203	050-H01600	HEX NUT M16	

③④ ASSY LOCK ARM (DSP-2220)

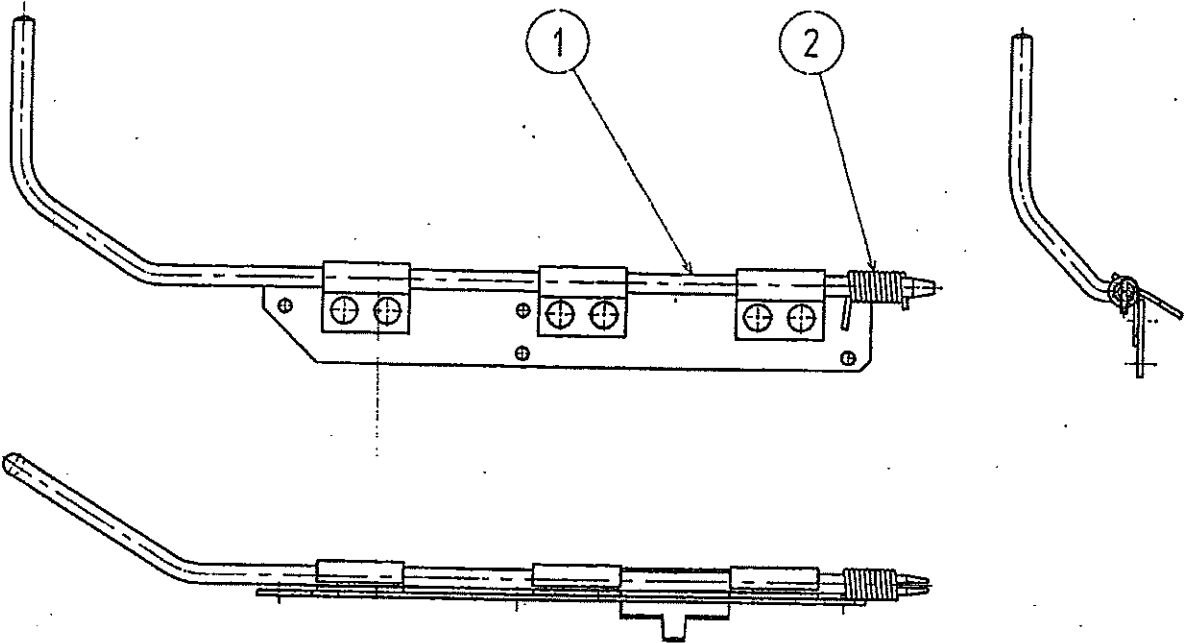

ITEM NO.	PART NO.	DESCRIPTION	NOTE
1	DSP-2221	LOCK ARM	
2	DSP-2222	TORSION SPRING	

35 ASSY AIR VALVE (DSP-2250)

(D-1/2)

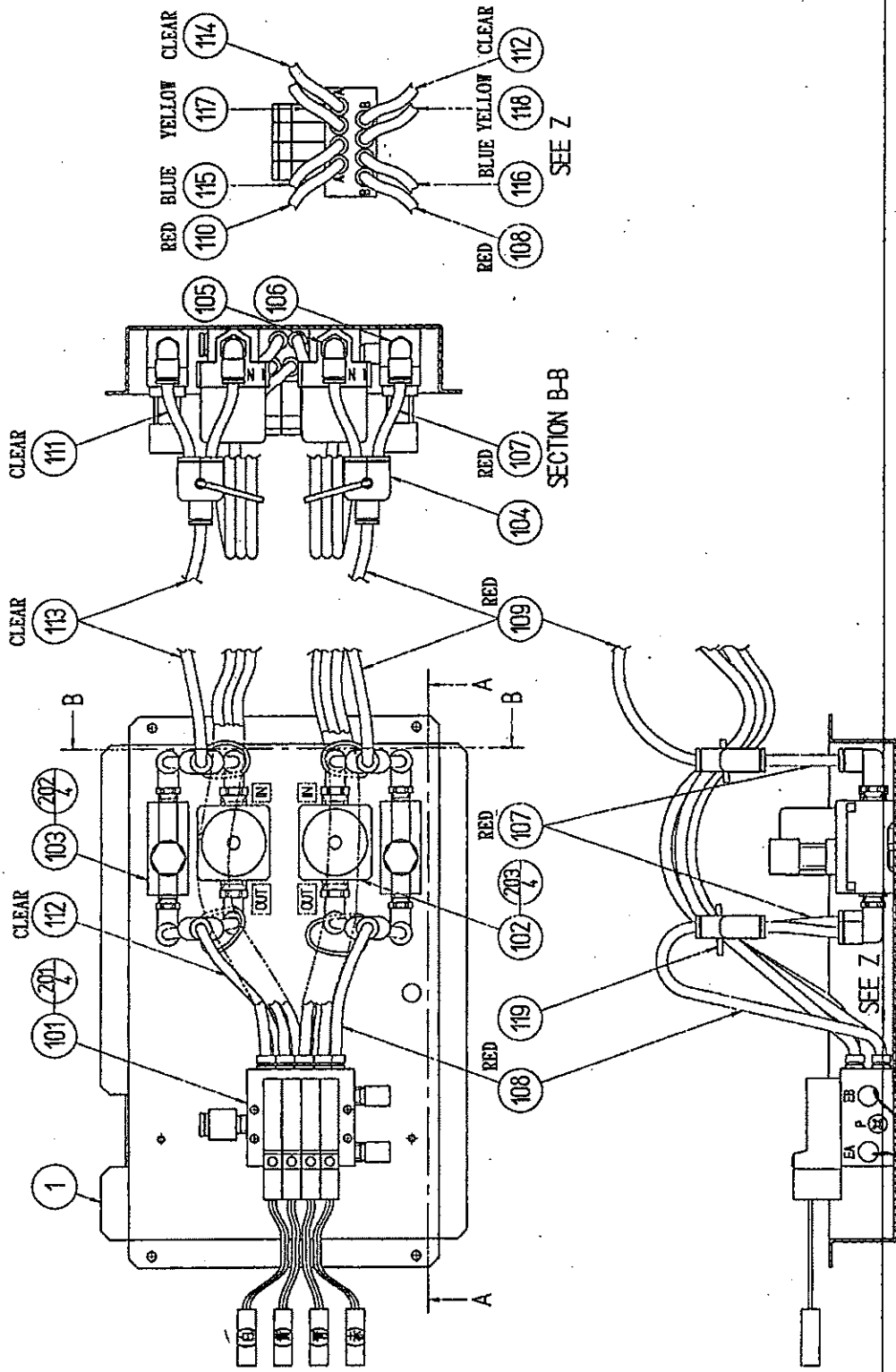

R.S.

③5 ASSY AIR VALVE (DSP-2250)

(D-2/2)

ITEM NO.	PART NO.	DESCRIPTION	NOTE
1	DSP-2251	VALVE BASE	
101	601-7780	AIR VALVE 5PORTX4	
102	601-6249	AIR VALVE 2PORT	
103	601-6246	SPEED CONTROLER 1/8	
104	601-6813	AIR JOINT 6-6 YU-TYPE	
105	601-6715	AIR JOINT 6-1/4 L TYPE	
106	601-6257	AIR JOINT 6-1/8 L TYPE	
107	601-6843-10060	AIR TUBE $\phi$ 6-RED-60	
108	601-6843-10200	AIR TUBE $\phi$ 6-RED-200	
109	601-6843-10450	AIR TUBE $\phi$ 6-RED-450	
110	601-6843-10640	AIR TUBE $\phi$ 6-RBD-640	
111	601-6843-00060	AIR TUBE $\phi$ 6-CLEAR-60	
112	601-6843-00200	AIR TUBE $\phi$ 6-CLEAR-200	
113	601-6843-00450	AIR TUBE $\phi$ 6-CLEAR-450	
114	601-6843-00640	AIR TUBE $\phi$ 6-CLEAR-640	
115	601-6843-2069D	AIR TUBE $\phi$ 6-BLUE-690	
116	601-6843-20770	AIR TUBE $\phi$ 6-BLUE-770	
117	601-6843-30690	AIR TUBE $\phi$ 6-YELLOW-690	
118	601-6843-30770	AIR TUBE $\phi$ 6-YELLOW-770	
119	601-0460	PLASTIC TIE BELT 100MM	
120	209-0023	CONN CLOSED END	
121	280-5008	CORD CLAMP $\phi$ 15	
122	601-5526-080	BUSH 1.6t	
201	000-P00435-W	M SCR PH W/FS M4 $\times$ 35	
202	000-P00408-W	M SCR PH W/FS M4 $\times$ 8	
203	000-P00510-W	M SCR PH W/FS M5 $\times$ 10	
301	600-6447-61	WIRE HARN VALVE L LOWER	
302	600-6447-62	WIRE HARN VALVE L UPPER	
303	600-6447-63	WIRE HARN VALVE R LOWER	
304	600-6447-64	WIRE HARN VALVE R UPPER	
305	600-6447-65	WIRE HARN VALVE L QUICK	
306	600-6447-66	WIRE HARN VALVE R QUICK	

③⑥ ASSY BASE LID F (DSP-2300)

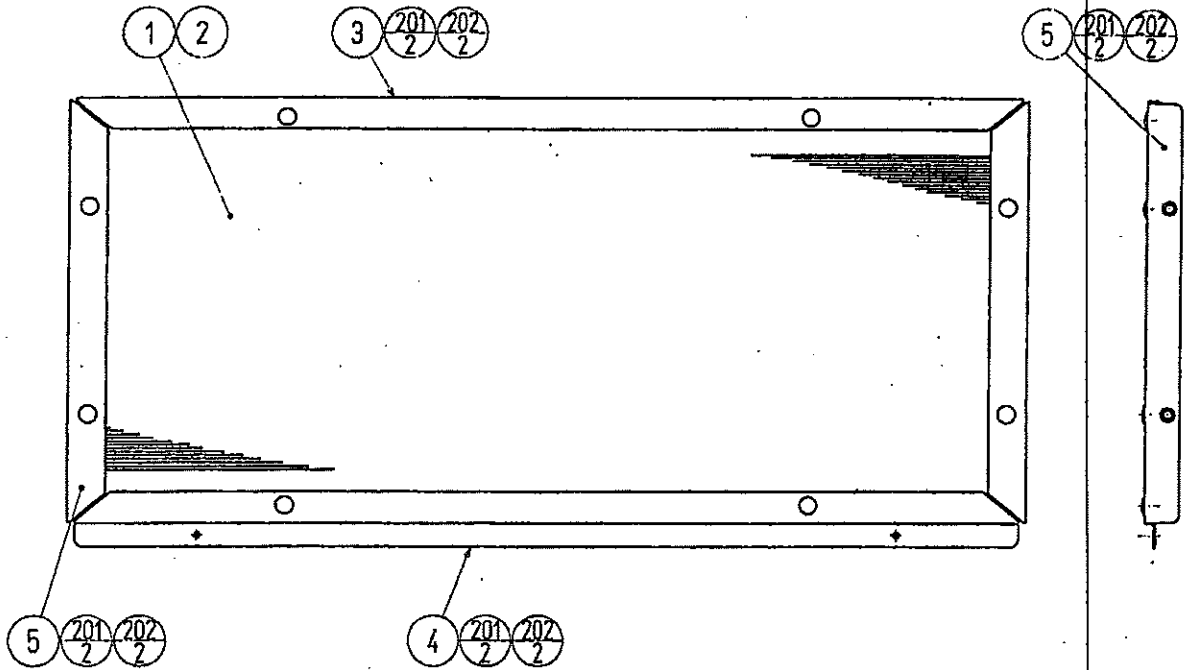

ITEM NO.	PART NO.	DESCRIPTION	NOTE
1	DSP-2301	BASE LID F	
2	DSP-2302	FLOOR MAT	
3	DSP-2303	LID EDGE F	
4	DSP-2304	LID EDGE R	
5	DSP-2305	LID EDGE S	
201	031-000410-0C	CRG BLT CRM M4×10	
202	050-F00400	FLG NUT M4	

37 | ASSY GUIDE BRKT (DSP-2400)

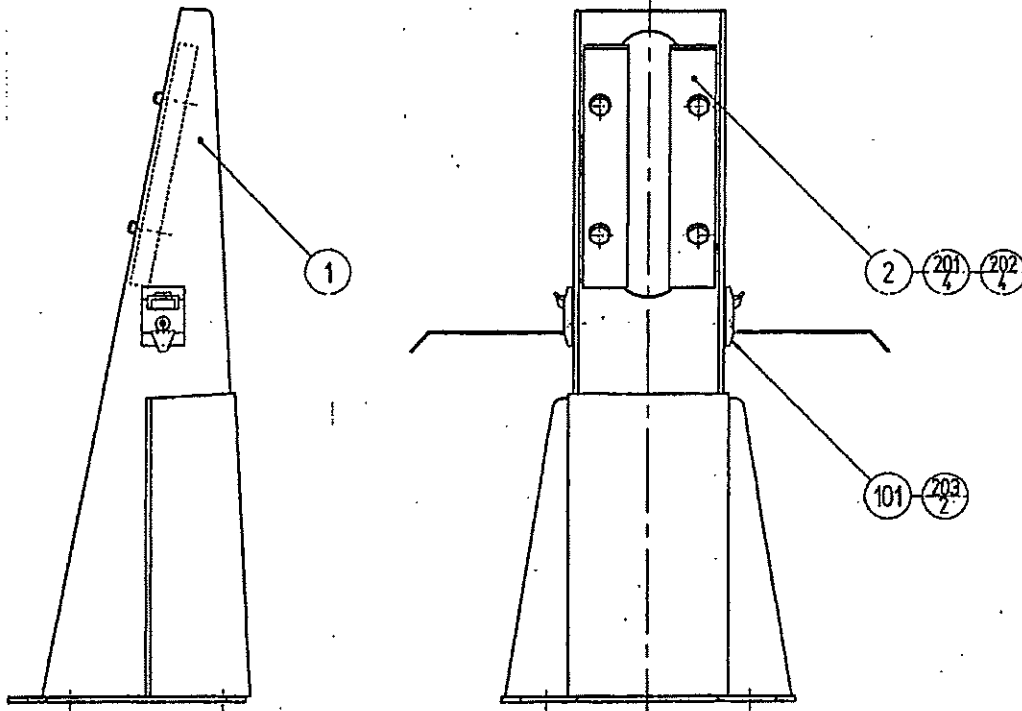

ITEM NO.	PART NO.	DESCRIPTION	NOTE
1	DSP-2401	GUIDE BRKT	
2	SLC-2016	GUIDE	
101	280-5009-01	CORD CLAMP 21	
201	030-000620-S	HEX BLT W/S M6×20	
202	060-F00600	FLT WSHR M6	
203	000-F00308	M SCR FH M3×8	

③⑧ ASSY AIR CYLINDER L (DSP-2500)

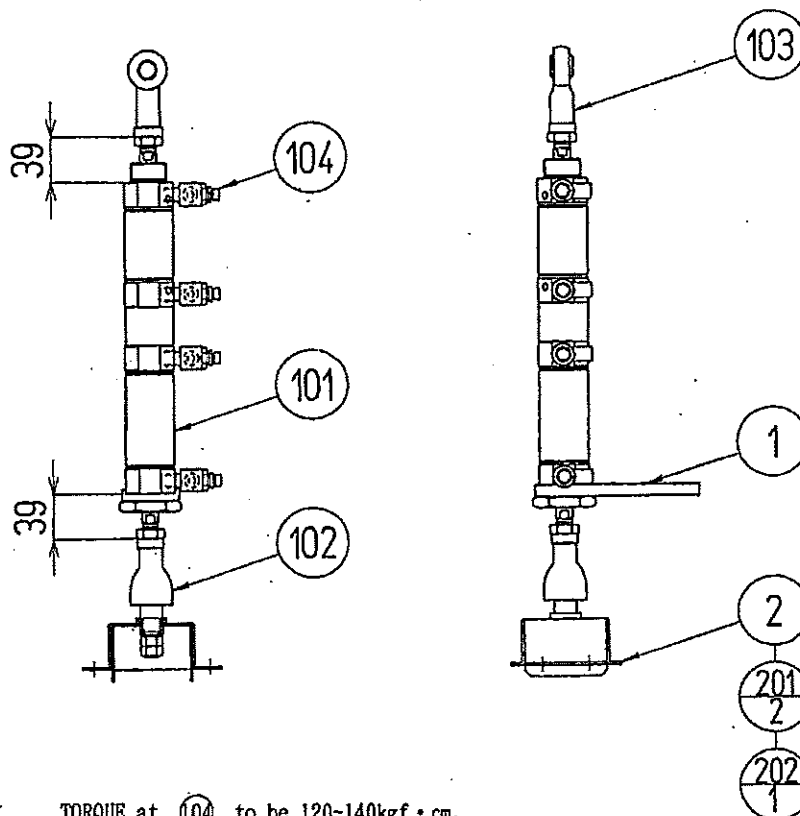

ITEM NO.	PART NO.	DESCRIPTION	NOTE
1	DSP-2501	STOPPER BLOCK	
2	DSP-2502	LINK BALL HOLDER	
101	601-7784	AIR CYLINDER 40-40A+20A	
102	111-0040	LINK BALL 14 P=1.5	
103	111-0041	ROD END 14 P=1.5	
104	601-7785	SP-CON JOINT 6-1/4 OUT	
201	FAS-500011	HEX NUT P=1.5 M14	
202	060-S01400	SPR WSHR M14	



③ ASSY AIR CYLINDER R (DSP-2600)

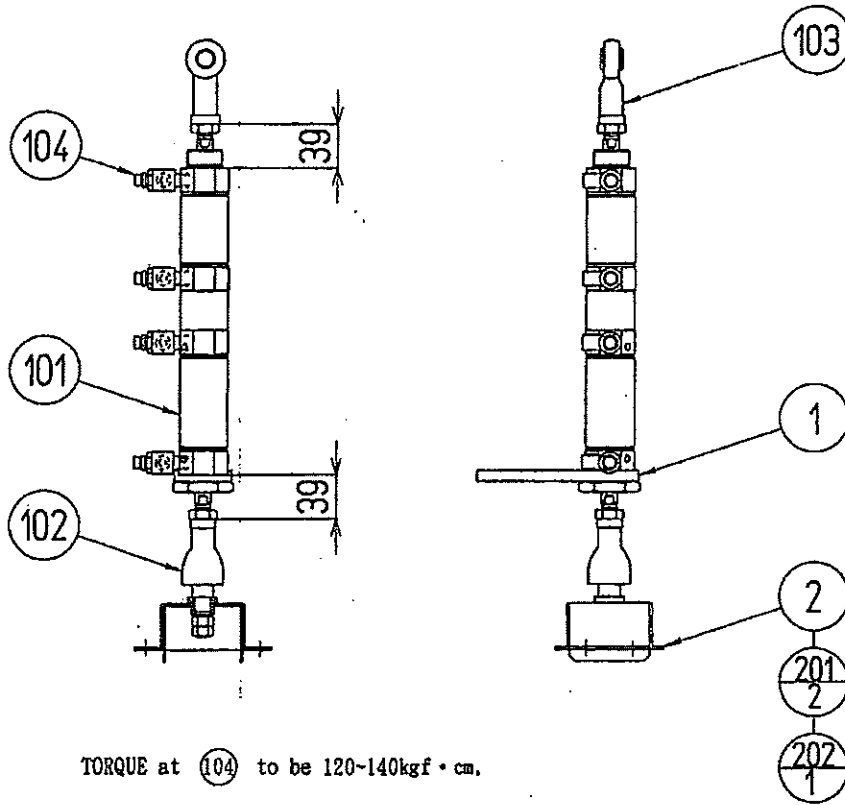

ITEM NO.	PART NO.	DESCRIPTION	NOTE
1	DSP-2501	STOPPER BLOCK	
2	DSP-2502	LINK BALL HOLDER	
101	601-7784	AIR CYLINDER 40-40A+20A	
102	111-0040	LINK BALL 14 P=1.5	
103	111-0041	ROD END 14 P=1.5	
104	601-7785	SP-CON JOINT 6-1/4 OUT	
201	FAS-500011	HEX NUT P=1.5 M14	
202	060-S01400	SPR WSHR M14	

④ ASSY PWR SPLY (DSP-4000)

(D-1/2)

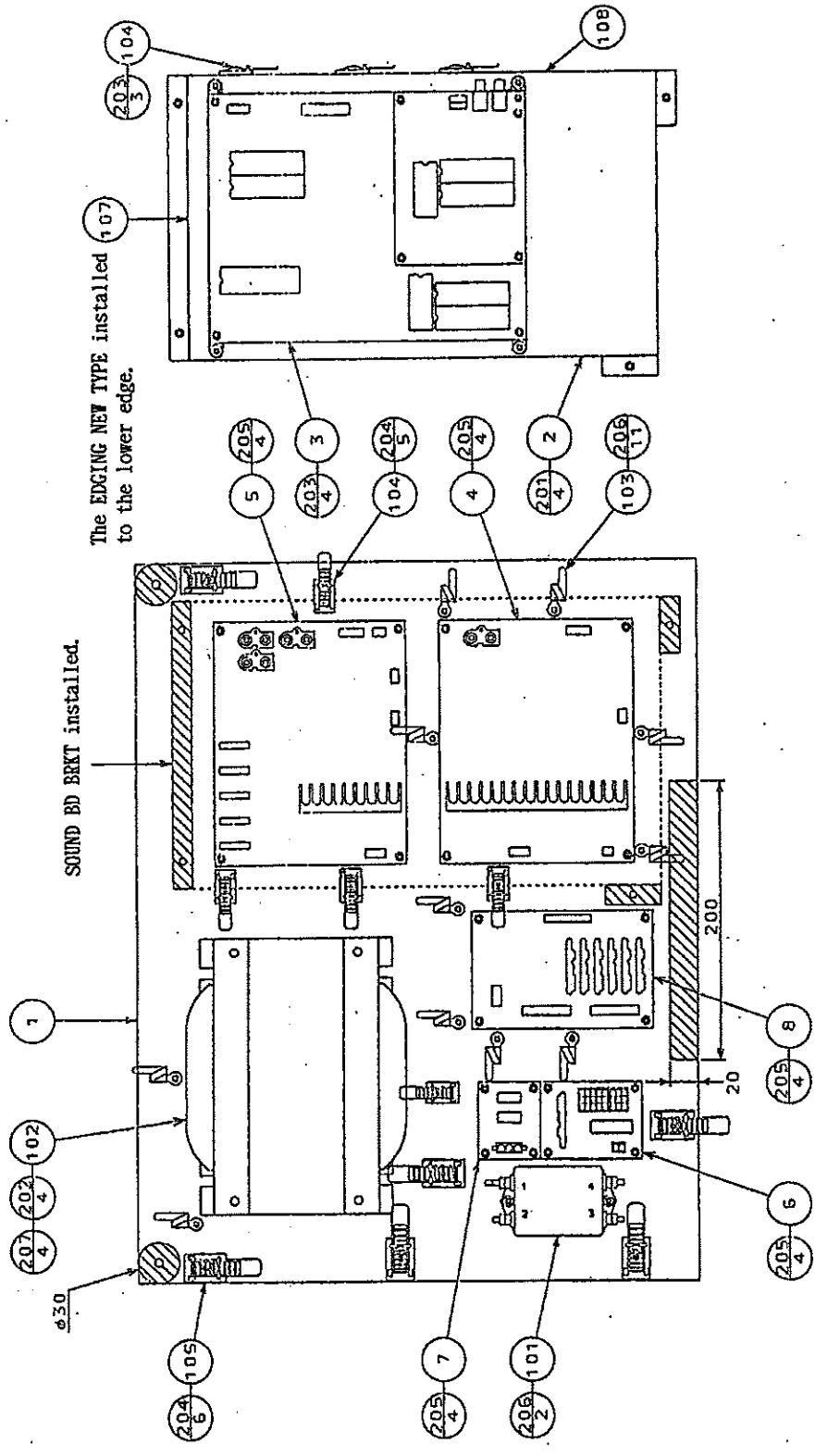

Make sure that there is no wiring, etc. in the slash mark portions.

④ ASSY PWR SPLY (DSP-4000)

(D-2/2)

ITEM NO.	PART NO.	DESCRIPTION	NOTE
1	DSP-4001	WOODEN BASE PWR SPLY	
2	DSP-4002	SOUND BD BRKT	
3	837-10652	SOUND BD DAYTONA TWIN	
4	838-10018	AMP BD SERVO	
5	838-10141-07	MIXER & EQ. AMP. FOR S. WOOFBR	
6	838-10801	CONN BD B	
7	838-10802	CONN BD C	
8	839-0619-02	SSR BD 6	
101	270-5026	NOISE FILTER 20A	
102	560-5278	PWR XFMR 200V-240V	
103	280-0419	HARNBSS LUG	
104	280-5008	CORD CLAMP $\phi$ 15	
105	280-5009	CORD CLAMP $\phi$ 21	
106	601-0460	PLASTIC TIE BELT 100MM	
107	601-6231-B140	EDGING NEW TYPE	
108	601-6231-B330	EDGING NEW TYPE	
201	000-P00412-W	M SCR PH W/PS M4 $\times$ 12	
202	000-P00516-W	M SCR PH W/PS M5 $\times$ 16	
203	010-F00308	S-TITE SCR PH M3 $\times$ 8	
204	011-F00310	TAP SCR PH 3 $\times$ 10	
205	011-P00325	TAP SCR PH 3 $\times$ 25	
206	011-T03512	TAP SCR TH 3.5 $\times$ 12	
207	068-552016	FLT WSHR 5.5-20 $\times$ 1.6	
301	600-6447-04	WIRE HARN N. FILTER IN	
302	600-6447-05	WIRE HARN N. FILTER & XFMR	
303	600-6447-06	WIRE HARN XFMR 12.8V	
304	600-6447-07	WIRE HARN CONN BD B & C	
305	600-6447-08	WIRE HARN XFMR 19V	
306	600-6447-10	WIRE HARN CONN & SSR BD	
307	600-6447-11	WIRE HARN LBADBR LAMP SIG	
308	600-6447-12	WIRE HARN SSR BD DC	
309	600-6447-16	WIRE HARN AMP BD OUT	
310	600-6447-19	WIRE HARN AMP BD VOL	
311	600-6447-21	WIRE HARN EXT AMP BD	
312	600-6447-22	WIRE HARN EQ BD OUT	
313	600-6447-24	WIRE HARN SOUND & EQ BD A	
314	600-6447-25	WIRE HARN SOUND & EQ BD B	
315	600-6447-26	WIRE HARN SOUND BD NH6P	
316	600-6447-28	WIRE HARN SOUND BD DC IN	

④ ASSY ELEC (DSP-4100)

(D-1/2)

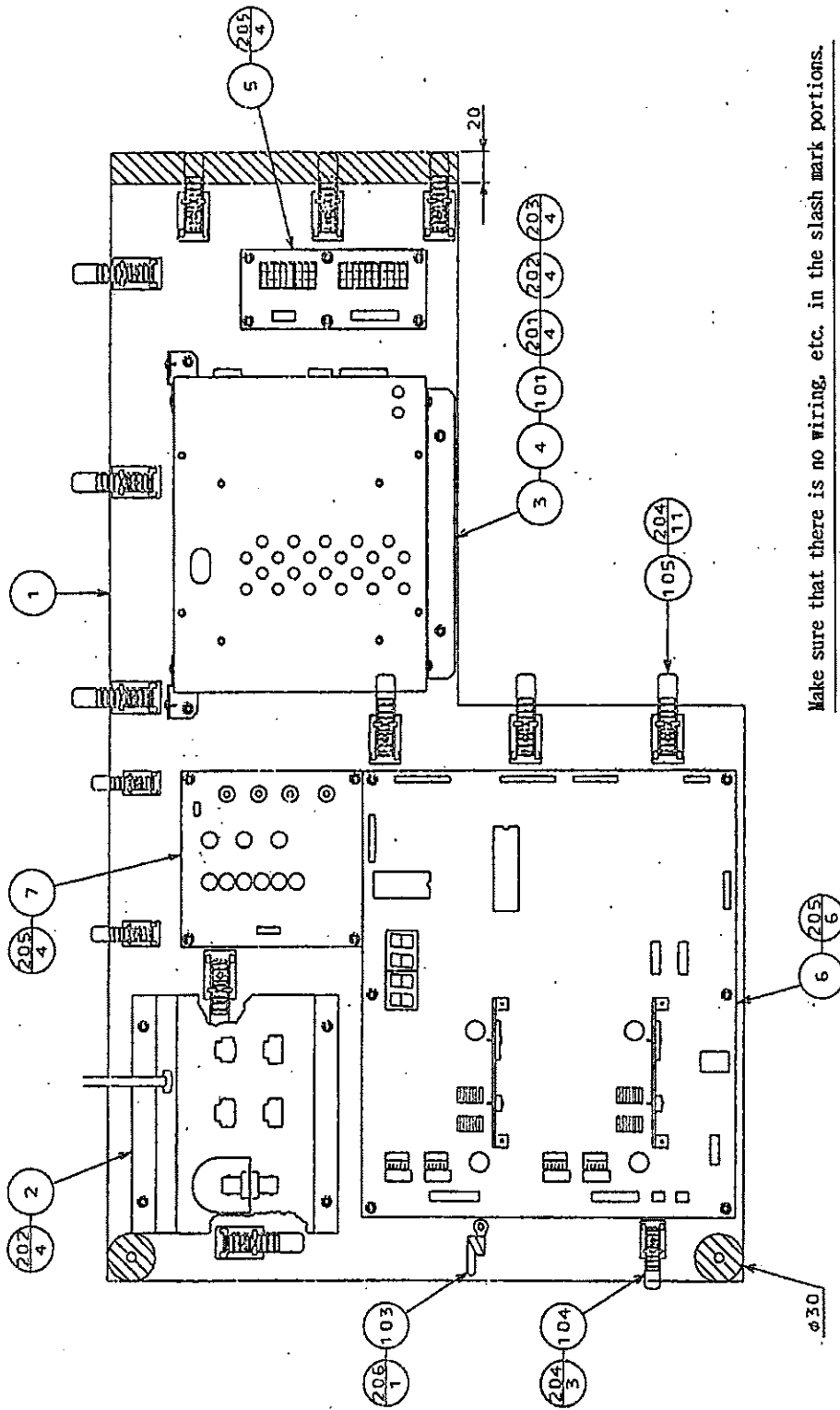

④1 ASSY ELEC (DSP-4100)

(D-2/2)

ITEM NO.	PART NO.	DESCRIPTION	NOTE
1	DSP-4101	WOODEN BASE ELEC	
2	DSP-4103	CONN PANEL	
3	DYN-4103	SW. REGU BRKT A	
4	DYN-4104	SW. REGU BRKT B	
5	838-10800	CONN BD A	
6	838-11297	DRIVE BD DSP	
7	839-0582	VPM BUFFBR BD	
101	400-5221	SW REGU 5V12A, 6A, 12V1.5A-5V.1A	
102	601-0460	PLASTIC TIE BBLT 100MM	
103	280-0419	HARNBSS LUG	
104	280-5008	CORD CLAMP $\phi$ 15	
105	280-5009	CORD CLAMP $\phi$ 21	-01 also acceptable.
201	000-P00406-W	M SCR PH W/FS M4 $\times$ 6	
202	000-P00412-W	M SCR PH W/FS M4 $\times$ 12.	
203	010-P00308-F	S-TITE SCR PH W/F M3 $\times$ 8	
204	011-F00310	TAP SCR PH 3 $\times$ 10	
205	011-P00325	TAP SCR PH 3 $\times$ 25	
206	011-T03512	TAP SCR TH 3.5 $\times$ 12	
301	600-6295-01	WIRE HARN AC SKT RE	
302	600-6447-09	WIRE HARN EXT AC 100V ELEC	
303	600-6447-18	WIRE HARN EXT SPEAKER ELEC	
304	600-6447-29	WIRE HARN AC IN	
305	600-6447-30	WIRE HARN SW REGU DC OUT A	
306	600-6447-31	WIRE HARN SW REGU DC OUT B	
307	600-6447-32	WIRE HARN CONN BD A CN4	
308	600-6447-33	WIRE HARN CONN BD A 12P	
309	600-6447-34	WIRE HARN CONN BD A 18P	
310	600-6447-35	WIRE HARN CTRL BD RX	
311	600-6447-36	WIRE HARN CTRL BD TX	
312	600-6447-37	WIRE HARN CTRL BD AC OUT	
313	600-6447-38	WIRE HARN CTRL BD STEERING B	
314	600-6447-39	WIRE HARN BUFFER BD RGB IN	
315	600-6447-42	WIRE HARN EXT REACTION MECHA	
316	600-6447-45	WIRE HARN EXT CONT PNL	
317	600-6447-46	WIRE HARN EXT 6P PANEL	
318	600-6447-52	WIRE HARN EXT STEERING A	

④2 CONN PANEL (DSP-4103)

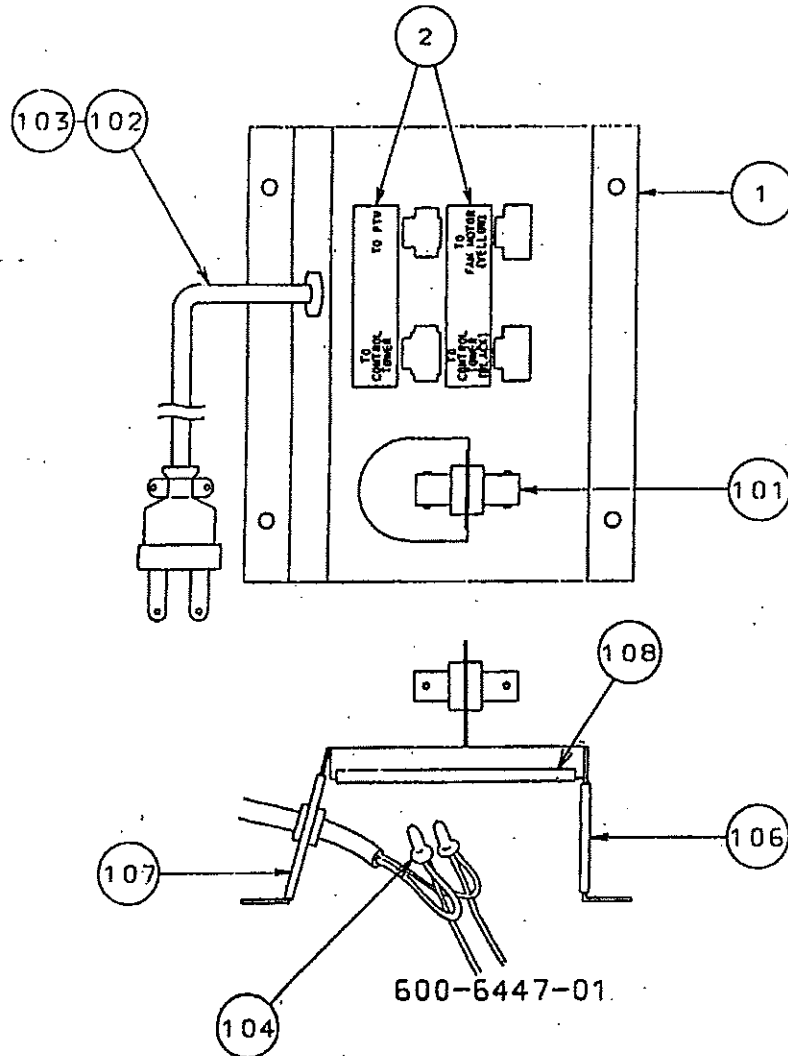

ITEM NO.	PART NO.	DESCRIPTION	NOTE
1	DSP-4102	CONN PANEL BRKT	
2	421-8699	STICKER CONN PANEL	
101	211-5517	CONN BNC EXT PNL	
102	600-6274	CA & PLUG ASSY 15A 200V ONLY	
103	280-5134-6N34	BUSHING STRAIN RELIEF 6N34	
104	209-0032	CONN CLOSED END	
105	601-0460	PLASTIC TIE BELT 100MM	
106	601-6231-B035	EDGING NEW TYPE	
107	601-6231-B040	EDGING NEW TYPE	
108	601-6231-B080	EDGING NEW TYPE	
301	600-6447-01	WIRE HARN EXT AC CABLE	

④③ ASSY SHIELD CASE (DSP-4200)

(D-1/2)

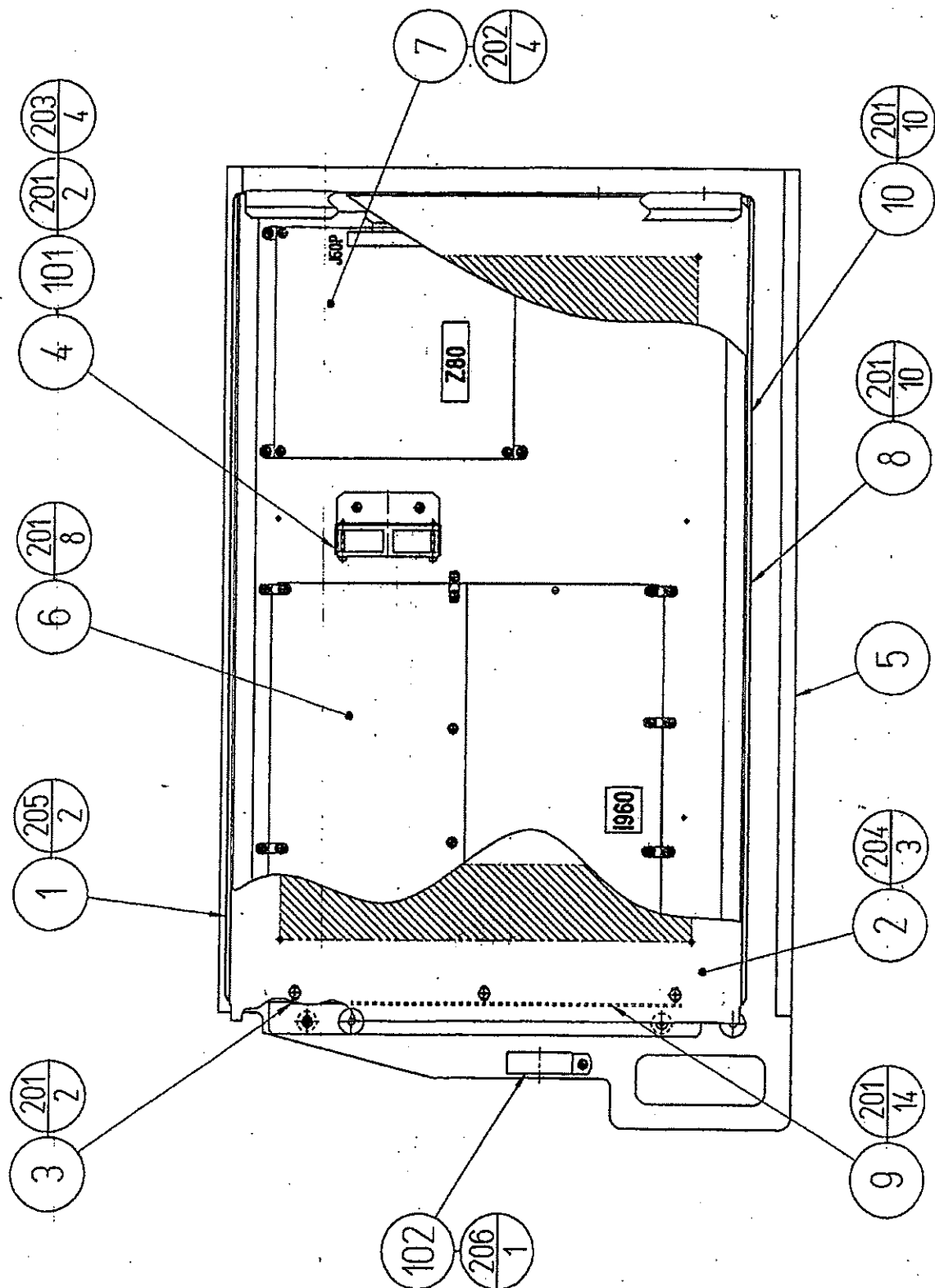

④3 ASSY SHIELD CASE (DSP-4200)

D-2/2)

ITEM NO.	PART NO.	DESCRIPTION	NOTE
1	DYN-2401	SHIELD CASE MAIN & I/O	
2	DYN-2402	CASE LID	
3	DYN-2403	OPTICAL WIRE LID	
4	DYN-2405	FAN BRKT	
5	DSP-4201	WOODEN BASE SHIELD CASE	
6	833-11338	GAME BD DAYTONA USA SP	
7	837-10539	I/O BD DAYTONA	
8	839-0658	FILTER BD DAYTONA I/O B	
9	839-0740	FILTER BD MODEL-2 MAIN DSP	
10	839-0733	FILTER BD DSP I/O	
101	260-0055	FAN MOTOR DC5V	
102	270-5009	LINE FILTER	
103	280-0419	HARNSS LUG	
104	280-0425	CORD CLAMP $\phi$ 10.	
105	280-5009	CORD CLAMP $\phi$ 21	-01 also acceptable
106	209-0023	CONN CLOSED BND	
107	601-0460	PLASTIC TIE BELT 100MM	
201	010-P00308-F	S-TITE SCR PH W/F M3 $\times$ 8	
202	010-P00310-F	S-TITE SCR PH W/F M3 $\times$ 10	
203	000-P00330-W	M SCR PH W/FS M3 $\times$ 30	
204	000-P00408-W	M SCR PH W/FS M4 $\times$ 8	
205	000-P00414-W	M SCR PH W/FS M4 $\times$ 14	
206	011-T03516	TAP SCR TH 3.5 $\times$ 16	
207	011-F00310	TAP SCR FH 3 $\times$ 10	
301	600-6363-76	WIRE HARN SHIELD CASE 7	
302	600-6363-77	WIRE HARN SHIELD CASE 8	
303	600-6363-79	WIRE HARN SHIELD CASE 10	
304	600-6363-80	WIRE HARN SHIELD CASE 11	
305	600-6363-81	WIRE HARN DC FAN B	
306	600-6447-43	WIRE HARN FLT BD AMP J50P	
307	600-6447-47	WIRE HARN EXT I/O BD DC	
308	600-6447-48	WIRE HARN I/O BD AMP J50P	
309	600-6447-49	WIRE HARN FLT BD SOUND	
310	600-6447-50	WIRE HARN FLT BD DC IN	
311	600-6447-51	WIRE HARN FLT BD RGB OUT	
312	600-6447-55	WIRE HARN FLT BD A/D	



44) ASSY. AMP BASE (DSP-4300)

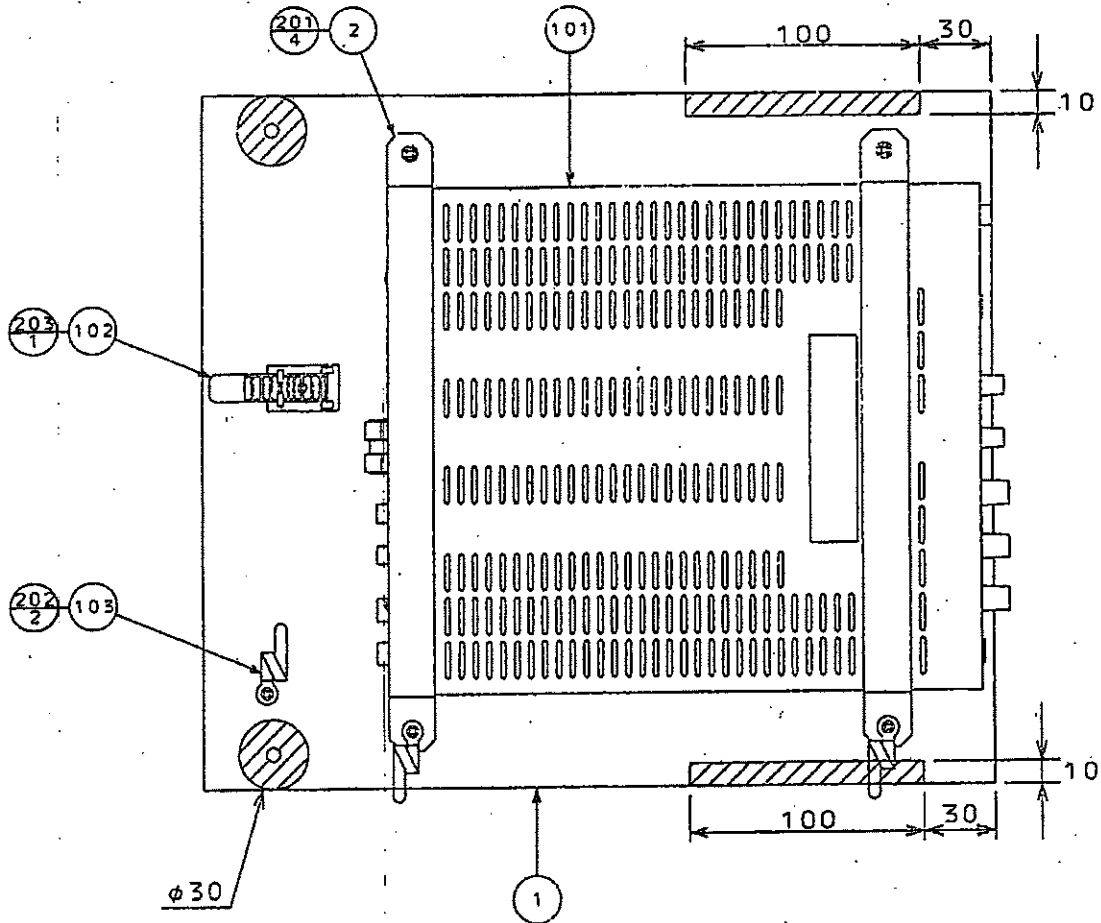

Make sure that there is no wiring, etc. in the slash mark portions.

ITEM NO.	PART NO.	DESCRIPTION	NOTE
1	DSP-4301	WOODEN BASE AMP	
2	DSP-4302	HOLD BELT	
3	DYN-1025	RUBBER CUSHION	
101	601-7604	POWER AMP SRA-50	
102	280-5009	CORD CLAMP $\phi 21$	-01 also acceptable.
103	280-0419	HARNESS LUG	
201	000-P00412-W	M SCR PH W/FS M4 $\times$ 12	
202	011-T00312	TAP SCR TH 3 $\times$ 12	
203	011-F00310	TAP SCR FH 3 $\times$ 10	
301	600-6448-10	WIRE HARN AMP OUT	
302	600-6448-11	WIRE HARN MIC IN	

45 ASSY PWR SPLY TOWER (DSP-4400)

D-1/2)

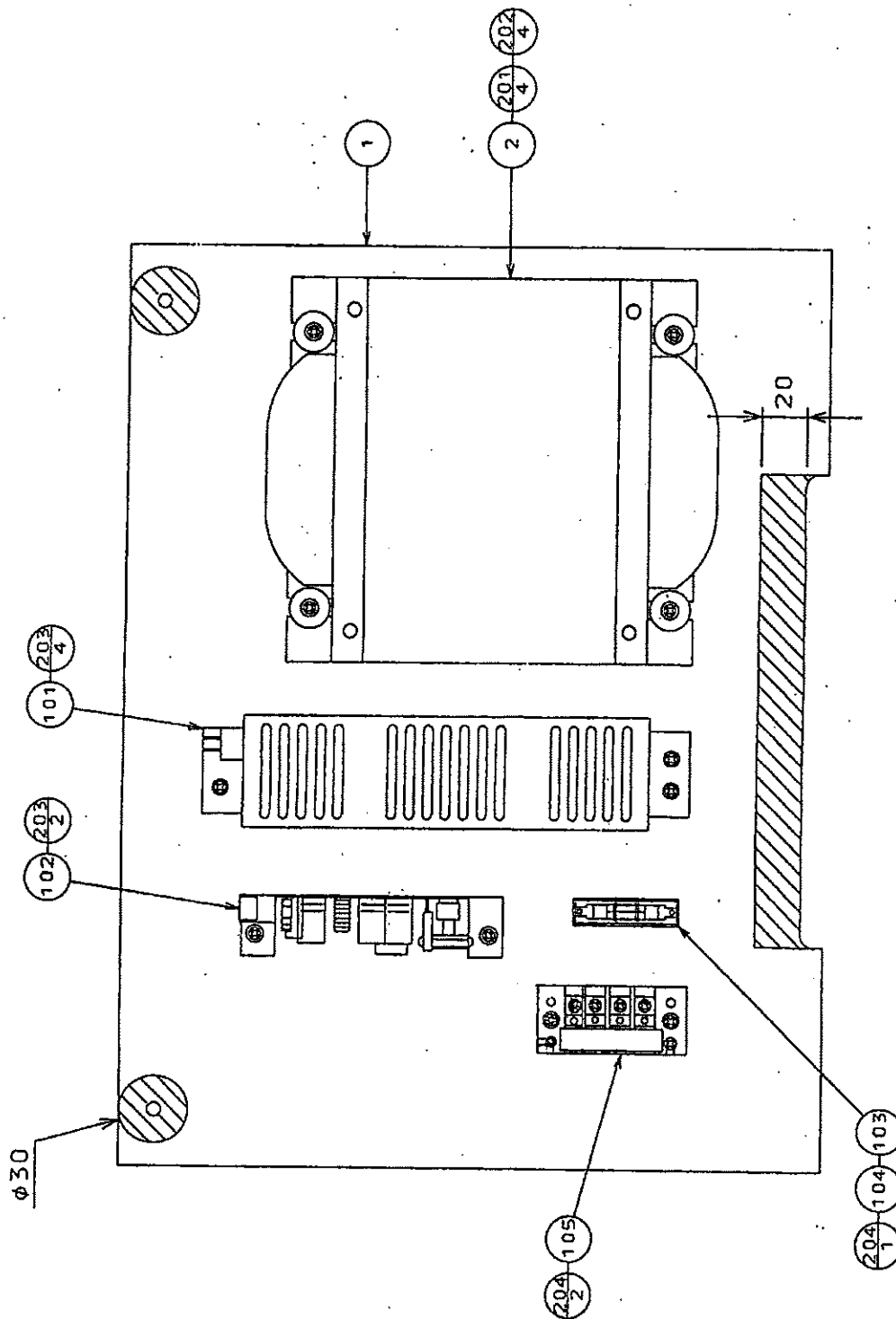

Make sure that there is no wiring, etc. in the slash mark portions.

(45) ASSY PWR SPLY TOWER (DSP-4400)

(D-2/2)

ITEM NO.	PART NO.	DESCRIPTION	NOTE
1	DSP-4401	WOODEN BASE PST	
2	560-5236	PWR XFMR 200-240V 100V12A	
101	400-5149	SW REGU AC100V +5V7A +12V1.5A -5V0.1A	
102	400-5065	SW REGU AC90-132V 5V2A	
103	514-5036-15000	FUSE 6.4 $\phi$ $\times$ 30 15000mA 125V	
104	514-5028	FUSE HOLDER 1P W/COVER	
105	117-5251	TERMINAL 4P 20A	
106	280-5009	CORD CLAMP $\phi$ 21	-01 also acceptable.
107	280-0419	HARNESS LUG	
201	000-P00516-W	M SCR PH W/FS M5 $\times$ 16	
202	068-552016	FLT WSHR 5.5-20 $\times$ 1.6	
203	011-T00312	TAP SCR TH 3 $\times$ 12	
204	011-T00316	TAP SCR TH 3 $\times$ 16	
205	011-F00310	TAP SCR FH 3 $\times$ 10	
301	600-6448-01	WIRE HARN XFMR IN	
302	600-6448-02	WIRE HARN XFMR OUT	
303	600-6448-03	WIRE HARN PWR SPLY AC OUT	
304	600-6448-04	WIRE HARN SW REGU IN A	
305	600-6448-05	WIRE HARN SW REGU IN B	
306	600-6448-06	WIRE HARN PWR SPLY DC OUT	
307	600-6448-35	WIRE HARN AC100V OUT	
308	600-6448-37	WIRE HARN FUSE	
309	600-6448-75	WIRE HARN TERMINAL	

④⑥ ASSY TOWER ELEC (DSP-4500)

(D-1/2)

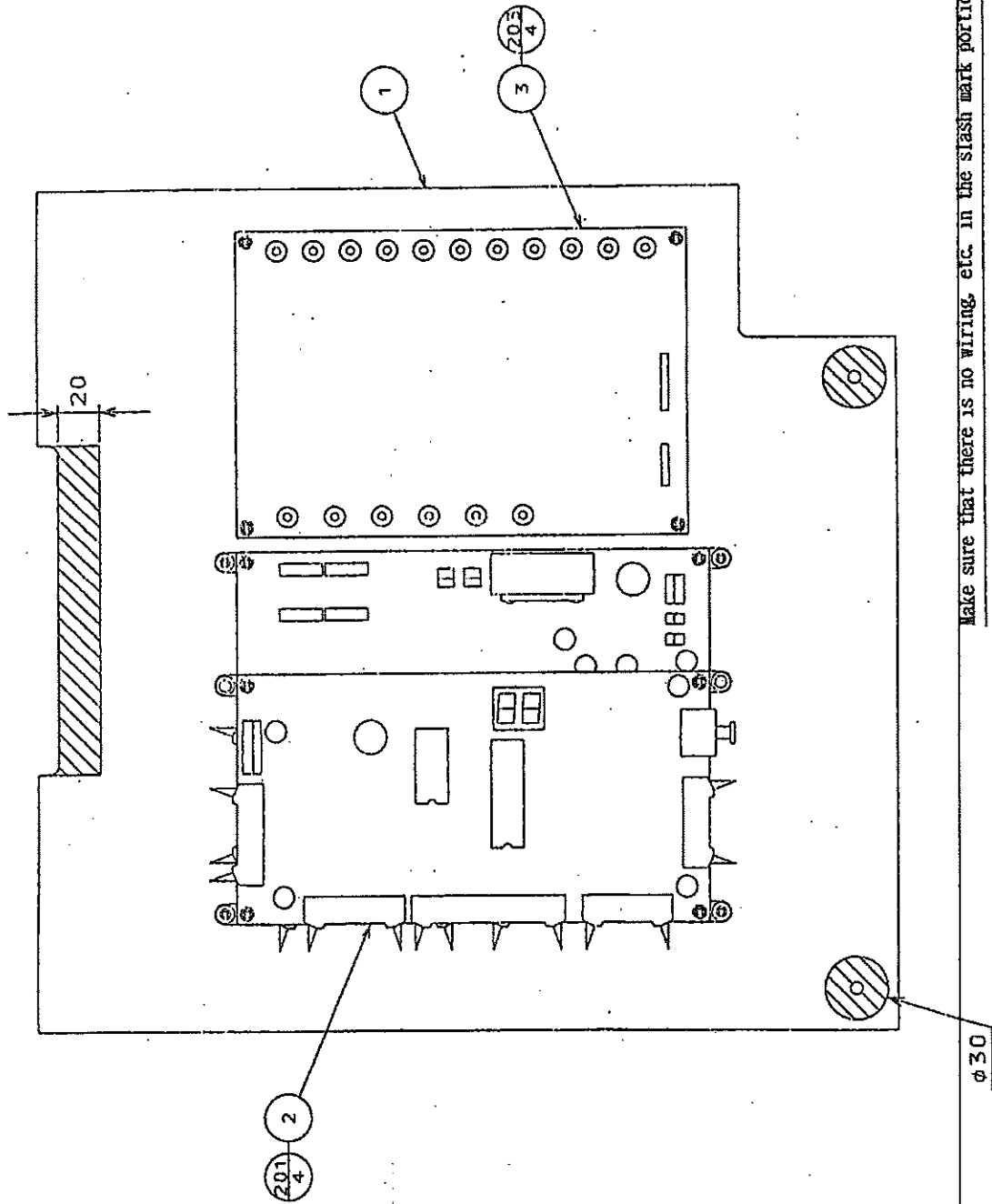

④6 ASSY TOWER ELEC (DSP-4500)

(D-2/2)

ITEM NO.	PART NO.	DESCRIPTION	NOTE
1	DSP-4501	WOODEN BASE TOWER ELEC	
2	837-11340	CONTROL BD DSP	
3	838-9731	VIDEO SWITCHER BD 11IN 6OUT	
101	280-5009	CORD CLAMP $\phi$ 21	-01 also acceptable.
102	280-0419	HARNBESS LUG	
103	601-0460	PLASTIC TIE BELT 100MM	
201	011-P00310	TAP SCR FH 3 $\times$ 10	
202	011-T00312	TAP SCR TH 3 $\times$ 12	
203	011-P00325	TAP SCR PH 3 $\times$ 25	
301	600-6448-14	WIRE HARN VIDEO & CONT BD	
302	600-6448-16	WIRE HARN ELEC ENTRY SW	
303	600-6448-17	WIRE HARN ELEC PANEL SW	
304	600-6448-30	WIRE HARN TOWER CONTROL BD	

④⑦ DAYTONA SP BANNER KIT FOR 8P (LIST-K674)

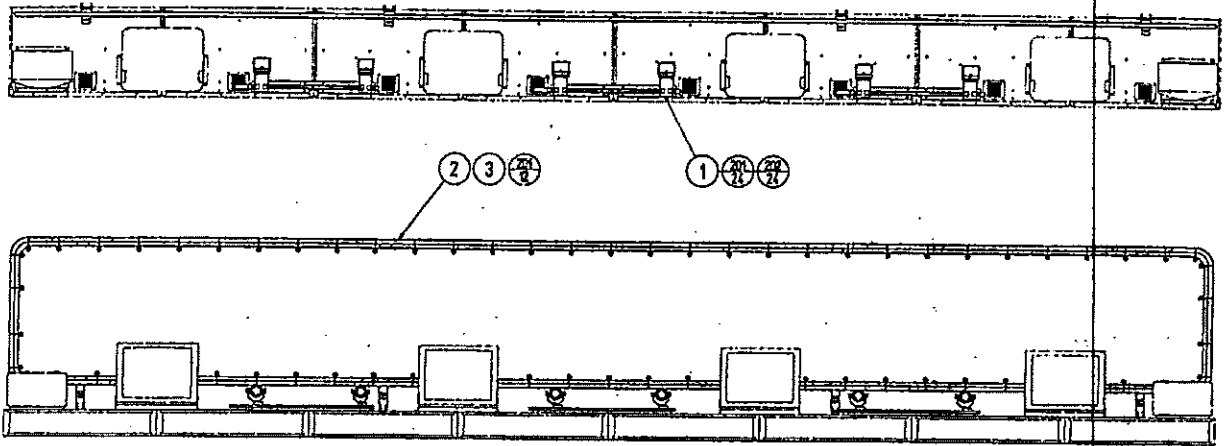

ITEM NO.	PART NO.	DESCRIPTION	NOTE
1	DSP-0220	ASSY SPOT LIGHT	
2	DSP-0230	ASSY BANNER	
3	SLC-0006	FLT WASHBR 8, 4-25×2	
201	030-000830-SB	HEX BLT W/S BLK M8×30	
202	060-F00800-OB	FLT WSHR BLK M8	
301	600-6448-52	WIRE HARN SPOT LIGHT	

④8 DAYTONA SP BANNER KIT FOR 4P (LIST-K674-01)

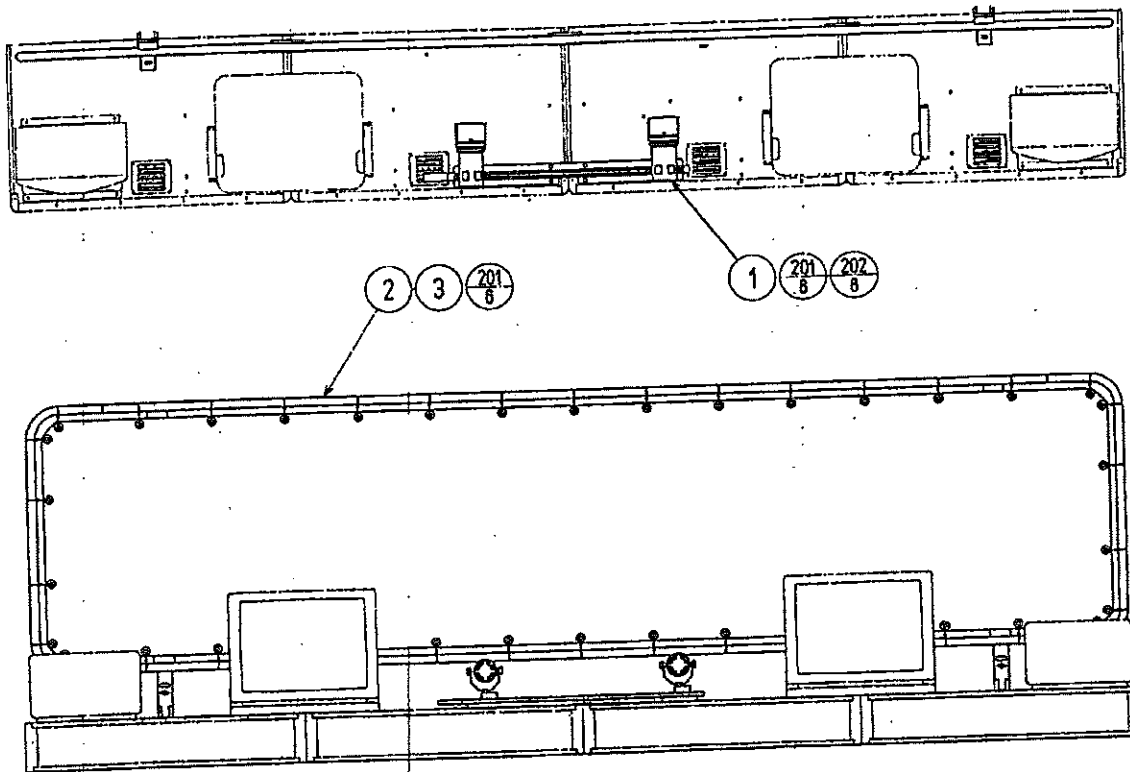

ITBM NO.	PART NO.	DESCRIPTION	NOTE
1	DSP-0220	ASSY SPOT LIGHT	
2	DSP-0260	ASSY BANNER 4P	
3	SLC-0006	PLT WASHBR 8, 4-25×2	
201	030-000830-SB	HBX BLT W/S BLK M8×30	
202	060-F00800-OB	PLT WSHR BLK M8	
301	600-6448-66	WIRE HARN SPOT LIGHT 4P	

## 26. WIRE COLOR CODE TABLE

THE WIRE COLOR CODE is as follow:

A	PINK
B	SKY BLUE
C	BROWN
D	PURPLE
E	LIGHT GREEN

Wires other than those of any of the above 5 single colors will be displayed by 2 alphanumeric characters.

1	RED
2	BLUE
3	YELLOW
4	GREEN
5	WHITE
7	ORANGE
8	BLACK
9	GRAY

If the right-hand side numeral of the code is 0, then the wire will be of a single color shown by the left-hand side numeral (see the above).

Note 1: If the right-hand side alphanumeric is not 0, that particular wire has a spiral color code. The left-hand side character shows the base color and the right-hand side one, the spiral color.

<Example> 51 ..... WHITE / RED

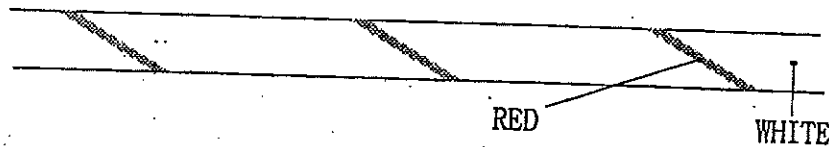

Note 2: The character following the wire color code indicates the size of the wire.

K:	AWG18, UL1015
L:	AWG20, UL1007
None:	AWG22, UL1007



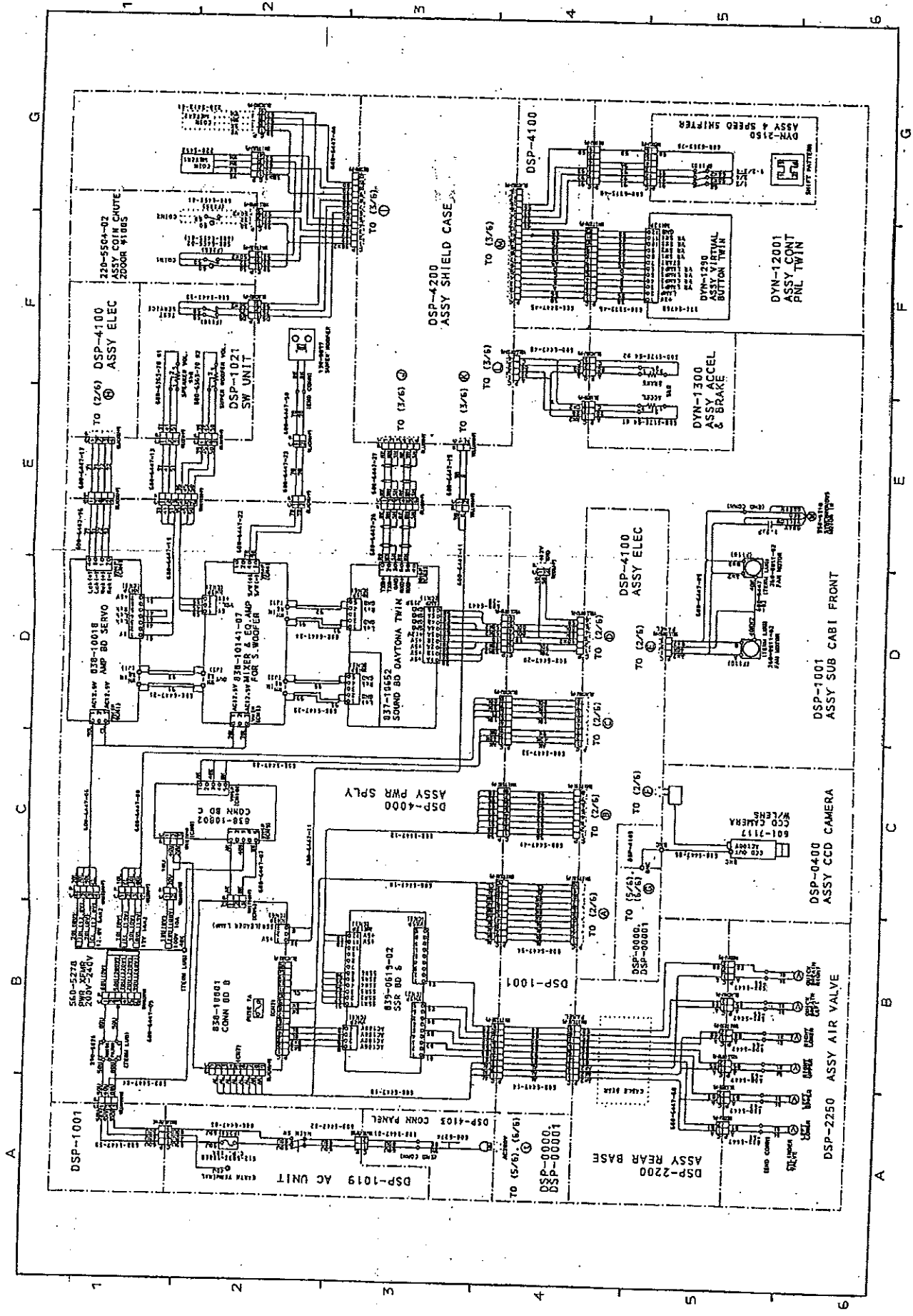

27. WIRING DIAGRAM (D-17)



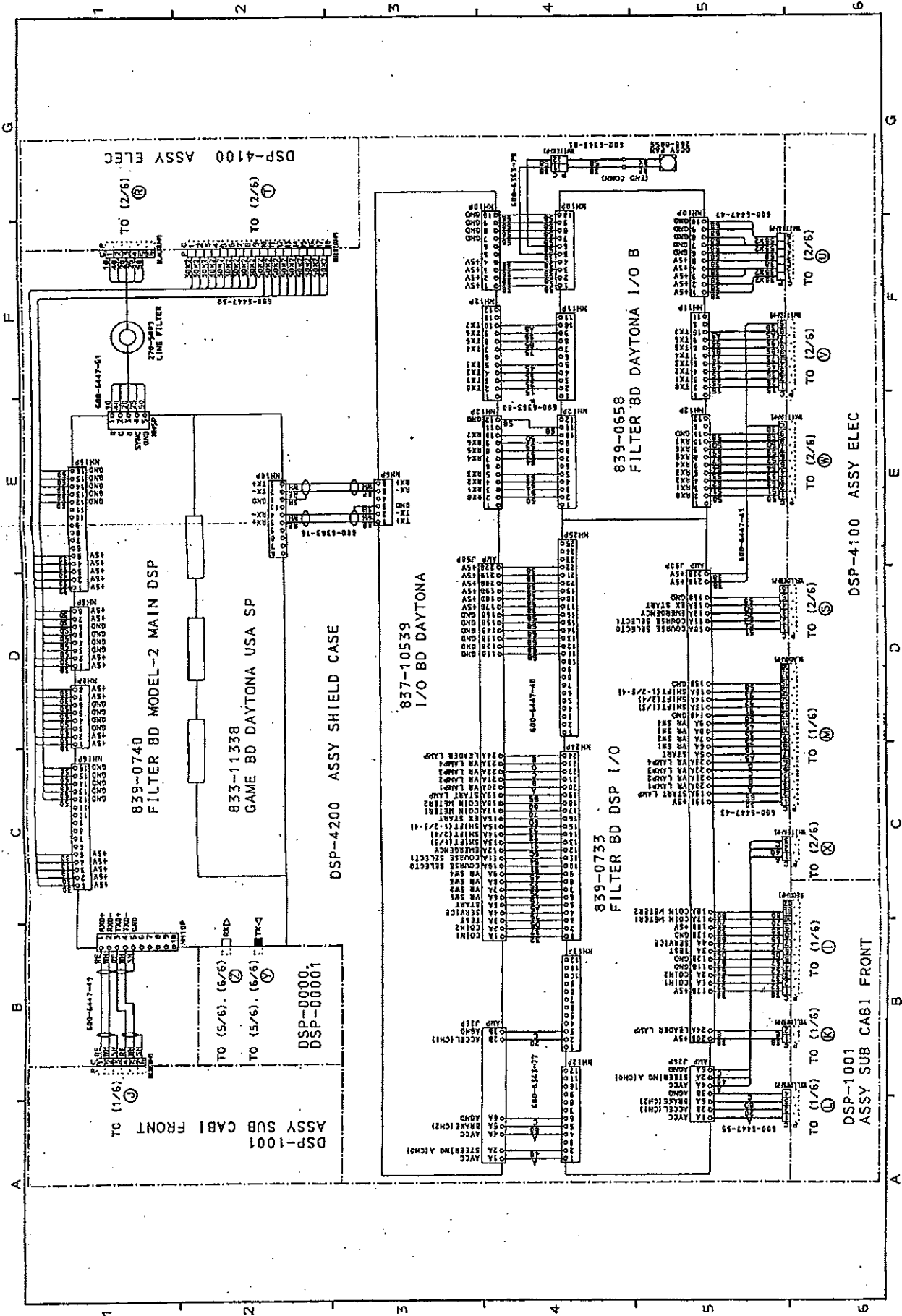

27. WIRING DIAGRAM (D-37)







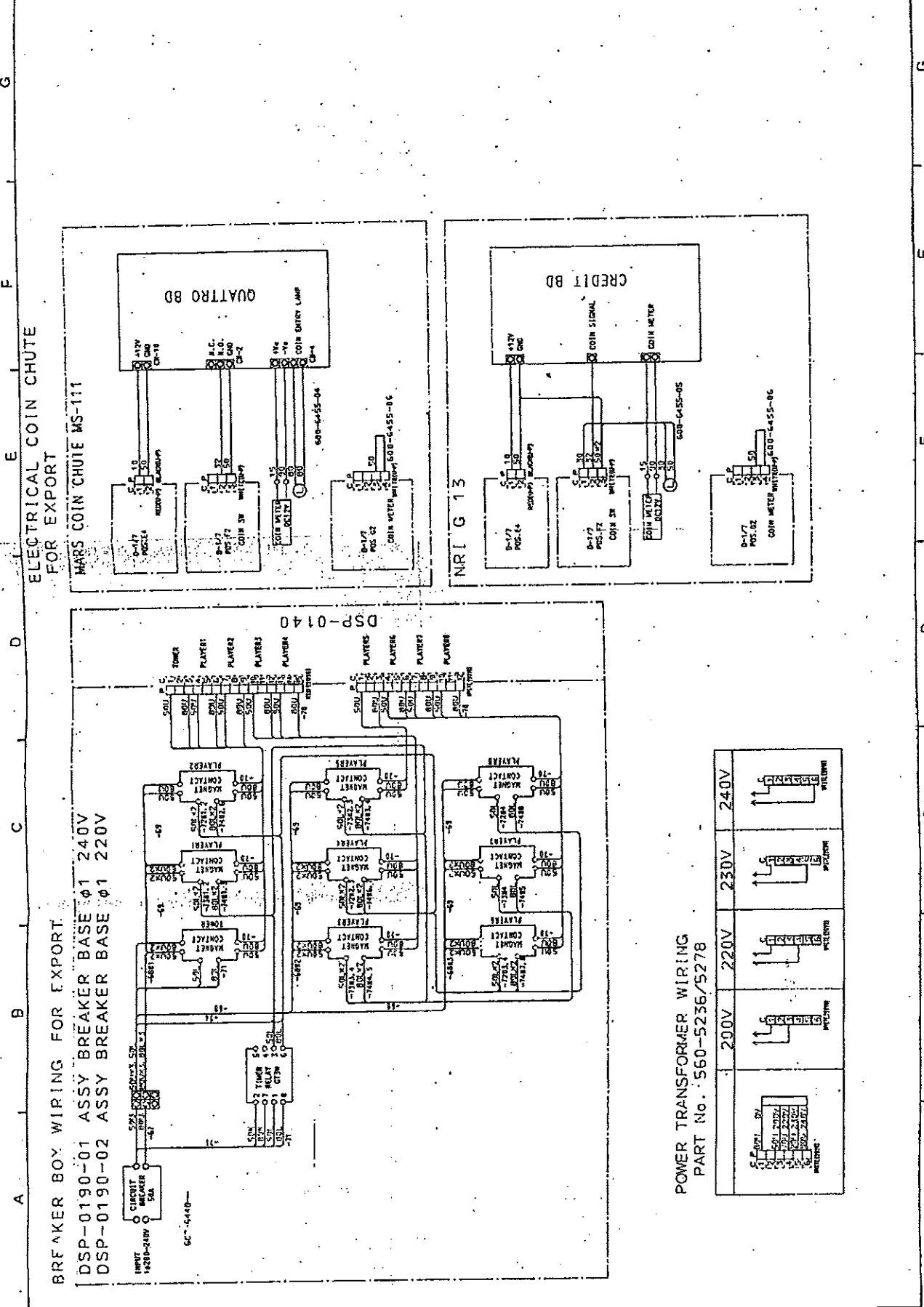

BRE^KER BOX WIRING FOR EXPORT.  
 DSP-0190-01 ASSY BREAKER BASE Ø1 240V  
 DSP-0190-02 ASSY BREAKER BASE Ø1 220V

ELECTRICAL COIN CHUTE  
 FOR EXPORT  
 MARS COIN CHUTE MS-111

NRI G 13

POWER TRANSFORMER WIRING  
 PART No. 560-5236/5278

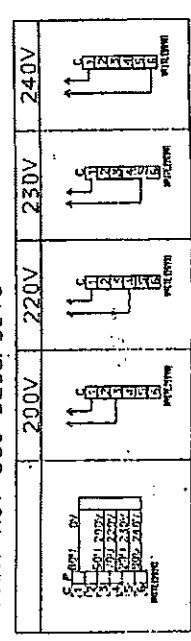

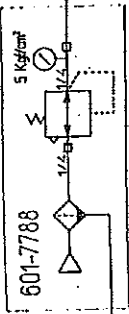

TUBE COLOR	TUBE COLOR CODE	TUBE COLOR CODE
00-00	0000	001 CLEAR
10-10	1010	101 RED
20-20	2020	202 BLUE
30-30	3030	303 YELLOW
80-80	8080	808 BLACK

**DAYTONA USA SPECIAL**

PIPING DIAGRAM

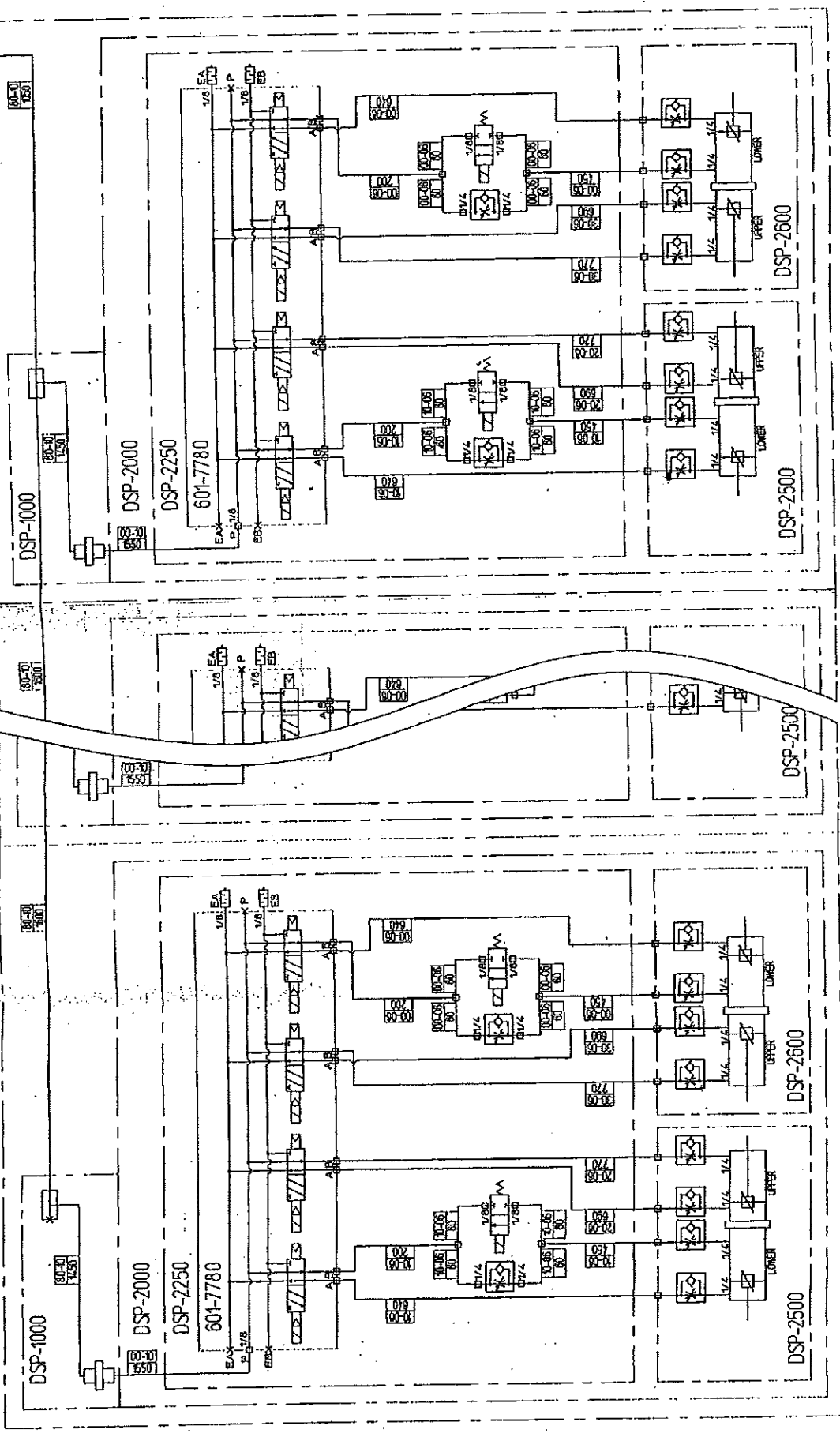

28. PIPING DIAGRAM

CAR No4 (No8)

CAR No2-3 (No2-7)

CAR No1