

FIREFOX

FIREFOX

FIREFOX

Operators Manual with Illustrated Parts Lists

Table of Contents

1	Set-Up	
	Game Overview	1-4
	Inspecting the Game	1-4
	Switch Information	1-5
	Game Play	1-6
2	Self Test	
	Not available for first printing	2-1
3	Maintenance	
	Preventive Maintenance	3-2
	Removing the Control Panel	3-2
	Laser-Disc Player	3-2
	Packing the Disc Player for Shipment	3-3
	Flight Control	3-3
	Coin Mechanism	3-4
	Game Cabinet and Display Shield	3-4
	Corrective Maintenance	3-4
	Flight Control	3-4
	Aligning the Potentiometers	3-9
	Calibrating the Flight Control	3-9
	Removing the CRT Assembly	3-9
	Removing the Tube and Speaker Board Assembly	3-10
4	Troubleshooting	
	Troubleshooting Aids	4-2
	Troubleshooting Techniques	4-2
	Soldering Techniques	4-3
	Troubleshooting Static-Sensitive Devices	4-4

List of Illustrations

Figure 1-1	Game Overview	1-2
Figure 1-2	Location of Game Switches	1-5
Figure 3-1	Handle Assembly	3-6
Figure 3-3	Steering Assembly	3-8
Figure 3-3	Fluorescent Tube & Speaker Board Removal and Display Access and Removal	3-11
Figure 4-1	Removing ICs (Cut Pin Method)	4-3
Figure 4-2	Removing IC Pins	4-3
Figure 4-3	Removing Solder from Plated-Through Holes	4-4
Figure 4-4	Removing Solder from Lead Connection Pads	4-4
<i>Illustrated Parts Lists—Common</i>		
Figure 5-1	Flight Control Assembly	5-2
Figure 5-2	Utility Panel Assembly	5-5
Figure 5-3	Coin Controls, Inc. Coin Door	5-6
Figure 5-4	Coin Acceptors, Inc. Coin Door	5-9
Figure 5-5	Main Printed-Circuit Board (PCB) Assembly	5-12
Figure 5-6	Graphics PCB Assembly	5-20
Figure 5-7	NTSC Demodulator PCB Assembly	5-26
Figure 5-8	Electromagnetic Interference (EMI) PCB Assembly	5-37
<i>Illustrated Parts Lists—Upright</i>		
Figure 6-1	Cabinet-Mounted Assemblies	6-2
Figure 6-2	Attraction Panel and Speaker Assembly	6-6
Figure 6-3	Control Panel and Audio Jack Assemblies	6-8
Figure 6-4	PCB Mounting Hardware—US	6-10
Figure 6-5	PCB Mounting Hardware—Ireland	6-12
<i>Illustrated Parts Lists—Sit-Down</i>		
	Not available for first printing	7-1

List of Tables

Table 1-1	Installation Specifications	1-4
-----------	---------------------------------------	-----

Safety Summary

The following safety precautions apply to all game operators and service personnel. Specific warnings and cautions will be found throughout this manual where they apply.

▲ WARNINGS ▲

Properly Ground the Game. Players may receive an electrical shock if this game is not properly grounded! To avoid electrical shock, do not plug in the game until it has been inspected and properly grounded. This game should only be plugged into a grounded 3-wire outlet. If you have only a 2-wire outlet, we recommend you hire a licensed electrician to install a grounded outlet. Players may receive an electrical shock if the control panel is not properly grounded! After servicing any parts on the panel, check that the grounding clip is firmly secured to the metal tab on the inside of the control panel. Only then should you lock up the game.

AC Power Connection. Before connecting the game to the AC power source, verify that the proper voltage-selection plug is installed on the game's power supply.

Disconnect Power During Repairs. To avoid electrical shock, disconnect the game from the AC power source before removing or repairing any part of the game. When removing or repairing the video display, extra precautions must be taken to avoid electrical shock because high voltages may exist within the display circuitry and cathode-ray tube (CRT) even after power has been disconnected. Do not touch internal parts of the display with your hands or metal objects! Always discharge the high voltage from the CRT before servicing this area of the game. To discharge the CRT: Attach one end of a large, well-insulated, 20-kV jumper to ground. Momentarily touch the free end of the grounded jumper to the anode by sliding it under the anode cap. Wait two minutes and discharge the anode again.

Use Only ATARI Parts. To maintain the safety integrity of your ATARI game, do not use non-ATARI parts when repairing the game. Use of non-ATARI parts or other modifications to the game circuitry may adversely affect the safety of your game, and injure you or your players.

Handle Fluorescent Tube and CRT With Care. If you drop a fluorescent tube or CRT and it breaks, it may implode! Shattered glass can fly six feet or more from the implosion.

Use the Proper Fuses. To avoid electrical shock, use replacement fuses which are specified in the parts list for this game. Replacement fuses must match those replaced in fuse type, voltage rating, and current rating. In addition, the fuse cover must be in place during game operation.

CAUTION

Properly Attach All Connectors. Make sure that the connectors on each printed-circuit board (PCB) are properly plugged in. Note that they are keyed to fit only one way. If they do not slip on easily, do not force them. A reversed connector may damage your game and void the warranty.

Set Up

How to Use This Manual

This manual, written for game operators and service technicians, describes your new ATARI game.

Chapter 1 contains a game overview, game specifications, inspection procedures, switch information, and option information.

Chapter 2 contains self-test procedures.

Chapter 3 contains maintenance and repair procedures.

Chapter 4 contains troubleshooting procedures.

Chapters 5, 6, and 7 contain illustrated parts lists. Chapter 5 contains the assemblies that are common to both the upright and sit-down cabinet. Chapter 6 contains the assemblies that are unique to the upright cabinet. Chapter 7 contains the assemblies that are unique to the sit-down cabinet. Notes in these chapters refer you to other places in the manual for more detailed information.

Schematic diagrams of the game circuitry are included as a supplement to this manual.

WARNING
Shock Hazard

To avoid electrical shock, do not plug in the game until it has been inspected and properly set up for the line voltage in your area.

This game should only be connected to a grounded 3-wire outlet. If you have only a 2-wire outlet, we recommend you hire a licensed electrician to install a grounded outlet. Players may receive an electrical shock if this game is not properly grounded.

Do not touch internal parts of the display with your hands or metal objects!

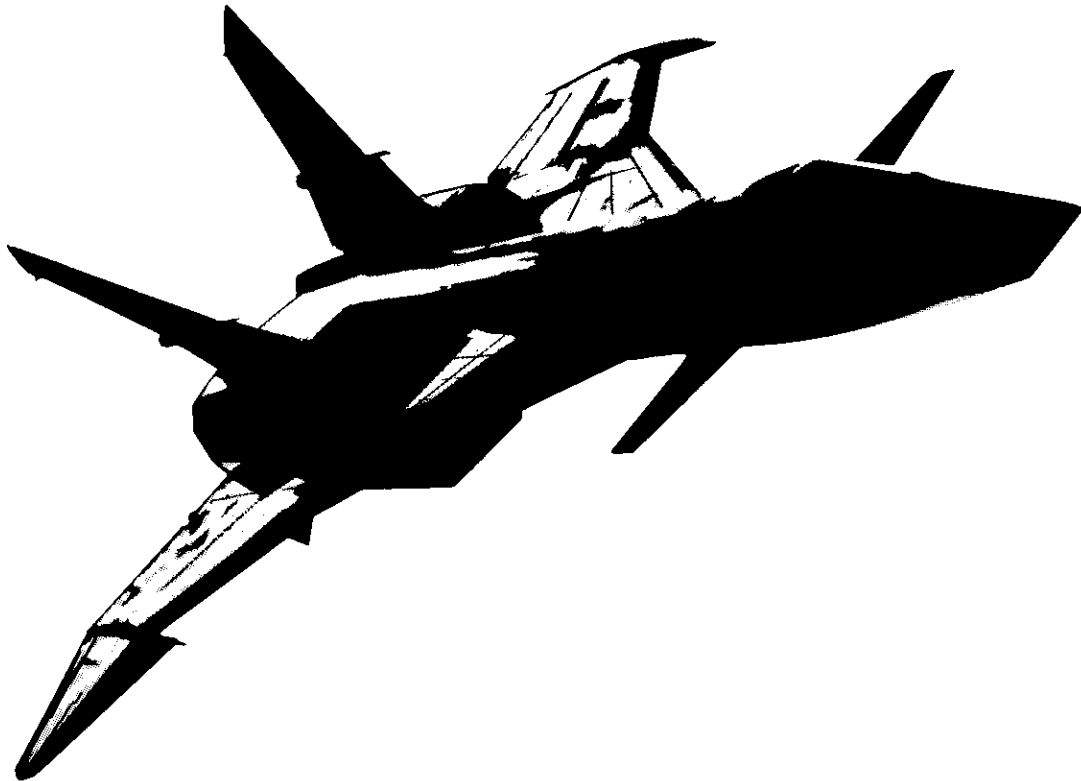

Chapter 1

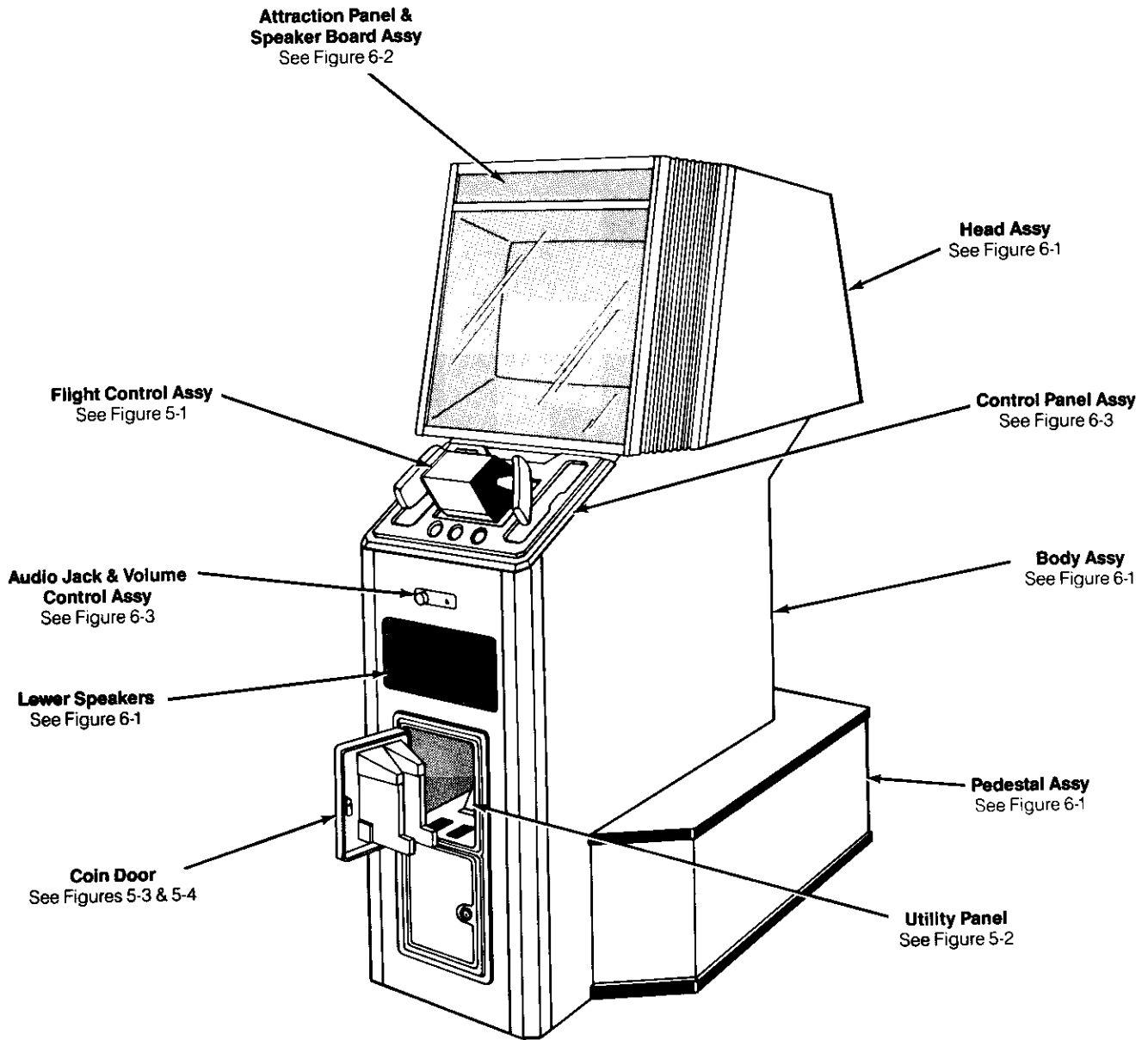

WARNING

Do not plug in the game until it has been inspected. This game should only be connected to a grounded 3-wire outlet. If you have only a 2-wire outlet, we recommend you hire a licensed electrician to install a grounded outlet. Players may receive an electrical shock if this game is not properly grounded!

Figure 1-1 Game Overview

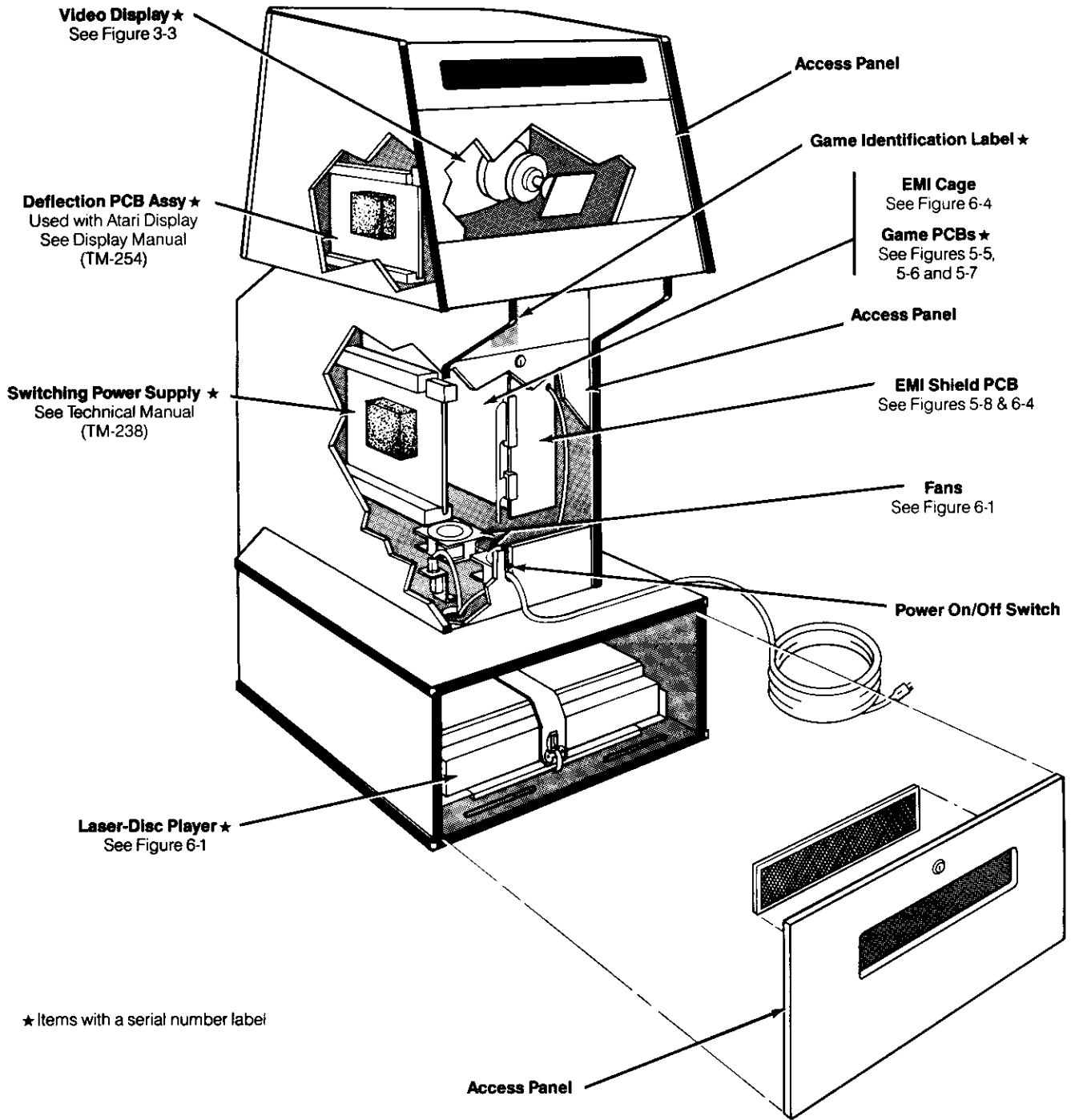

Figure 1-1 Game Overview, continued

Game Overview

FIREFOX* is a one-player game based on the suspenseful FIREFOX movie which starred that foxy maverick—Clint Eastwood! The awesome footage for this game was carefully selected from actual outtakes of the thriller. Even the voice you hear is Eastwood's own, lifted from the movie's voicetrack.

Sequences for FIREFOX are stored on a laser disc. ATARI LASERVIDEO™ technology has accomplished the union of laser disc and digital graphics to allow the player to star in his own first-person motion picture experience!

For an overview of the cabinet assemblies, see Figure 1-1.

New Features

FIREFOX has several new features:

- FIREFOX is Atari's first laser disc game: ATARI LASERVIDEO combines two technologies for an exciting experience for players.
- FIREFOX uses the new "high-tech" cabinet. Players can use their own headphones with the audio jack provided below the control panel.
- FIREFOX has four high-score tables and a pilots' table that *all* players can enter their initials into.
- FIREFOX introduces the "Heads Up" display. For a complete description see the Game Play section in this chapter.

Inspecting the Game

Please inspect your game carefully to ensure that it was delivered to you in good condition.

1. Examine the exterior of the game cabinet for dents, chips, or broken parts.
2. Remove the screws from the body access panel. Unlock and open this panel and the coin door. Inspect the interior of the game as follows:
 - a. Ensure that all plug-in connectors (on the game harnesses) are firmly plugged in. Replug any connectors found unplugged. Do not force connectors together. The connectors are keyed so they only fit in the proper orientation. *A reversed edge connector may damage a printed-circuit board (PCB) and will void your warranty.*
 - b. Ensure that all plug-in integrated circuits on each PCB are firmly plugged into their sockets.
 - c. Remove the tie-wrap that secures the coiled power cord inside the cabinet. Inspect the power cord for any cuts or dents in the insulation. Repair or

replace it if required. Place the square strain-relief plate in the wood slot at the bottom of the rear panel opening.

- d. Inspect the power supply. Make sure the harness is plugged in correctly. The switching power supply has exposed high voltages. We recommend that a qualified service technician check the power supply.
- e. Inspect other major subassemblies, such as the control panel, video display, EMI cage, fluorescent tube, and each PCB. Make sure they are mounted securely and that the green ground wires are connected.

▲ WARNING ▲

Replace fuses only with an identical type fuse with the same electrical rating. Please refer to TM-238 (the switching power supply manual) for information about fuse values in your game.

- f. The disc player is installed in the cabinet before the game is shipped with the FIREFOX laser disc already in the disc player. Therefore, the disc player should require no special set up. If you have trouble with the disc player, see Chapter 3 for instructions on how and where to send it for service.
- g. After applying power to the game, calibrate the flight control. The game circuitry monitors the position of the cursor on the display in relation to the flight control's vertical and horizontal position. Calibration is quickly accomplished by moving the cursor to all four extreme edges of the display. Calibration is also accomplished during normal game play, but may take a few seconds during game play to optimize.

Table 1-1 Installation Specifications

Characteristic	Specification
Power Consumption	240 W Nominal
Temperature	+5° to +38° C (+37° to +100° F)
Humidity	Not to exceed 95% relative
Line Voltage	100 to 132 VAC (or 200 to 264 VAC)
<i>Upright Cabinet</i>	
Width	25.25 in. (64.1 cm)
Depth	36 in. (91.4 cm)
Height	68.5 in. (174 cm)
<i>Sit-Down Cabinet</i>	
Width	25.25 in. (64.1 cm)
Length	83 in. (210.8 cm)
Height	59 in. (169.9 cm)

*FIREFOX is a trademark of Warner Bros. Inc. ©1982 Warner Bros. Inc. ©1983 Atari, Inc. All rights reserved.

CAUTION

The ambient air temperature required for proper operation of the disc player must be more than +5° C (+37° F).

If the game is cold when unpacked, allow it to reach room temperature before applying power.

coins entered into the game. The self-test switch initiates the Self-Test Mode. The auxiliary coin switch credits the game without activating a coin counter. See Figure 5-2 for details of these switches.

NOTE

The utility panel volume control adjusts the sound from both the custom sound chips and from the stereo signal generated by the laser disc.

Now plug the game into a *grounded* 3-wire outlet.

Switch Information

Power On/Off Switch

The power on/off switch is located on the back of the cabinet on the lower left side (see Figure 1-1).

Utility Panel Switches

The volume control, coin counter(s), self-test switch, and auxiliary coin switch are on the utility panel. The utility panel is located inside the upper coin door (see Figure 1-1). The volume control adjusts the level of sound produced by the game. The coin counter(s) records the number of

Volume Control for the Audio Jack

The volume control located below the control panel (see Figure 1-1) is used to adjust sound levels in a player's headphone set. The volume control on the utility panel does not affect the sound level in the headphones.

Option Switches

Three dual-inline-package (DIP) switches are located on the game PCB at locations C3, K6, and M2 (see Figure 1-2). Switches C3 and K6 consist of eight switches. Switch M2 consists of four switches. Use these switches to select different game play and pricing options

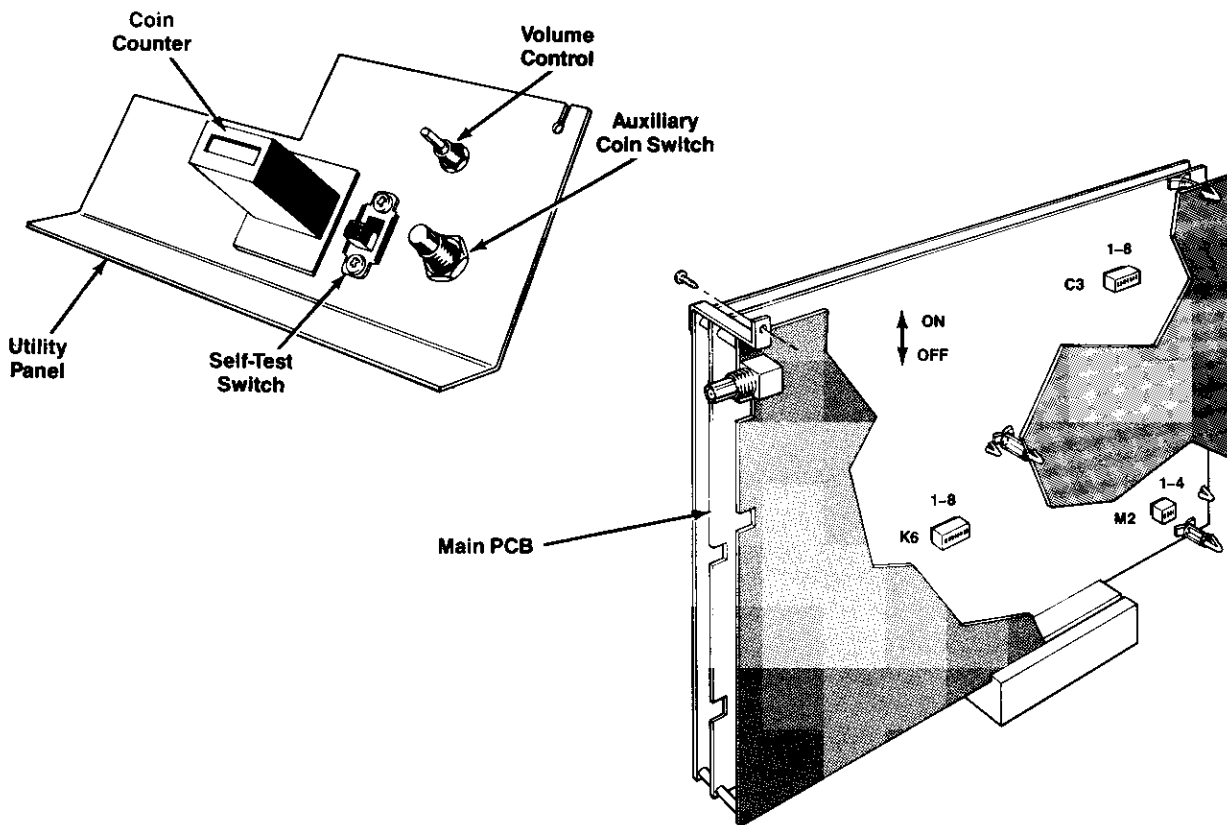

Figure 1-2 Switch Locations

Game Play

FIREFOX is a one-player laser-disc game with a color raster video display. It has 5 modes of operation: Attract Mode, Select-A-Mission Mode, Play Mode, High-Score Mode, and Self-Test Mode.

The FIREFOX game is a first for Atari for several reasons.

- The first laser-disc game designed by Atari.
- The first ATARI game that allows a player to use headphones (his own).
- The first time the player can use the ATARI Flight Control thumb buttons.
- The first generation of games that Atari is packaging in the high-tech cabinet.
- The first to allow *every* player (not just the best players) to enter his initials into a pilots' score table.

The sound effects for FIREFOX are seismic! They intensify the Attract and Play Modes with music, sound effects, and lots of phrases from the movie soundtrack. You'll hear Clint Eastwood saying the following:

"Homing device attached."
 "I'm going to take her up."
 "I'm going to take her down."
 "I'm going to take her down low to avoid an infrared fix."
 "Let's see what this thing can do. . ."
 "Missile cruiser contact dead ahead. . ."
 "Polar pack's in sight now."
 "Homing device just activated."
 "ECM picking up infrared detection beams."
 "They've got me locked on."
 "Contact point 90 miles and I'm flying on air."
 "We've got visibility again."
 "Estimated 3 miles to target."
 "Radar says all clear."
 "Nothing can touch us now."
 "Better ice up a cold one."
 "I'm coming home."
 "Hope it burns up the sky."
 "Second FIREFOX. . ."
 "Ah, we've got company. . ."
 "I'm on reserve tanks now."
 "I'm the best there is."
 "Boy is this a machine!"
 "They've spotted me."
 "Say brother, that's about as good as it gets."

During Game Play, Clint's voice is generated by the speech synthesizer chip, but during the Attract Mode, his voice and other sounds are from the laser disc. FIREFOX uses "stereo image enhancement" to simulate different distances between you and the sound source. This enhancement is particularly realistic if you use stereo headphones while playing the game.

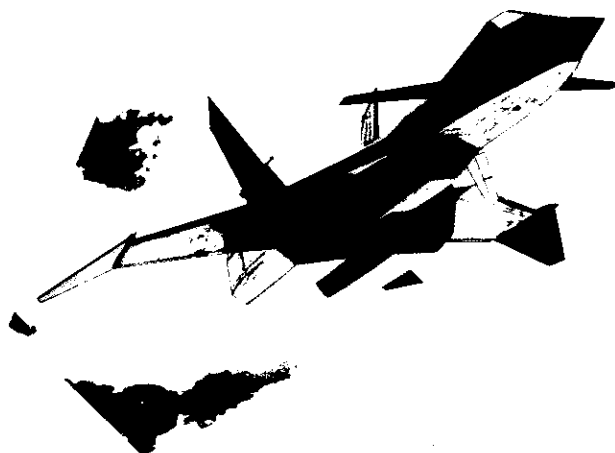

Attract Mode

The Attract Mode displays exciting sequences and sound effects from the movie. Then the words *PULL TRIGGER TO START*, © 1982 WARNER BROS. INC. and © 1983 ATARI, INC. ALL RIGHTS RESERVED appear, while the footage continues to roll underneath it.

The targets (radar, oncoming shots, missiles, and planes) are defined.

The high-score table and the pilots' table also appear during the Attract Mode.

Select-A-Mission Mode

When enough credits are registered to start Game Play, the Select-A-Mission Mode begins. Four missions appear on the screen—a 3000 mile mission, 6000 mile mission, 9000 mile mission, and a PRO MISSION. A map of each mission appears above the number of miles. (The PRO MISSION appears as a question mark because the course may vary.) All of the courses traverse western Russia and the Ural mountain range.

The 3000 mile mission has 1 leg, the 6000 mile mission has 2 legs, and the 9000 mile mission has 3 legs.

NOTE

In FIREFOX, a "leg" is similar to a wave.

You have six seconds to select a mission. To make a selection, you must move the flight control (to highlight the desired mission in gold).

The Play Mode starts when a mission is selected or after six seconds of the Select-A-Mission Mode has elapsed.

Play Mode

Play is based on the FIREFOX movie—your mission is to escape detection and successfully deliver the FIREFOX super-plane to the United States government. You have one life, but during that life you may complete more than one mission.

ATARI LASERVIDEO graphics combine the laser-disc image with the digitized image of the FIREFOX nose. As you play the game, you can see your target through the graphic overlays. This is an aid during Game Play.

When the Select-A-Mission Mode ends, the following instructions appear on the screen:

SHOOT: RADAR

SHOTS

PLANES

CONSERVE YOUR FUEL

Three numbers appear across the bottom of your screen. The number on the left is your score, the number in the middle is the number of targets you've shot down, and the number on the right is the number of fuel units you have remaining (you start with 80 units).

To begin your mission, pull up to take off. Messages appear during Game Play to guide you.

NOTE

When in the sky you use half as much fuel as when you're near the ground. However, in the sky you can be detected by twice as many radar scanners. Radar detection increases as Game Play progresses.

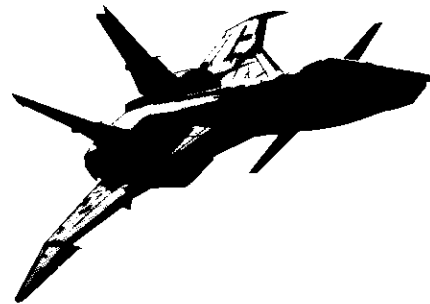

There are seven "Altitude Select" screens per leg of the mission. When you see this screen, move the flight control up or down to select whether you want to fly high or near the ground. The altitude select screen is a transitional third-person view of the FIREFOX (you'll notice that your nose and "Heads Up" display have disappeared from view).

If you are flying into a fatal situation (for example—flying into an ice cliff), an instruction clip from the movie intervenes. This clip shows a pilot's gloved hands pulling back on the flight control.

The words *HOMING DEVICE ACTIVATED* will appear as you near the end of the mission leg. This is a tie-in with the movie and means you are approaching the American submarine. Entering the trench also marks the final leg of the mission. During the landing sequence, you'll see a quick overhead view of the submarine, which is where you refuel. When you refuel, the screen turns grey and you are awarded points for refueling.

Description of Targets

Radar is a target. You are in a stealth plane, so only infrared (not regular) radar can detect you. Infrared radar will appear on the screen as small concentric circles. The radar is one of your targets. If you do not destroy the infrared radar, it grows. The outer three rings of the radar will turn black as it detects you and is ready to hit you.

Shots are targets. You and the enemy both have two types of projectiles (or shots)—one is a guided missile that grows and hits head on; the other is a volley of shots that behaves like machine gun spray. When you hit an oncoming shot, black flak appears (it's like a black cloud).

When you are hit by a volley of shots, a yellow flash covers the screen and you lose one fuel unit. (It's a good thing you have a self-sealing tank!) When you are hit by a missile, a yellow and black flash covers the screen and you lose four fuel units.

Planes are targets. When you hit a plane, flaming flak appears. Flaming flak also appears when you hit any other element (e.g., secret Soviet ground bases).

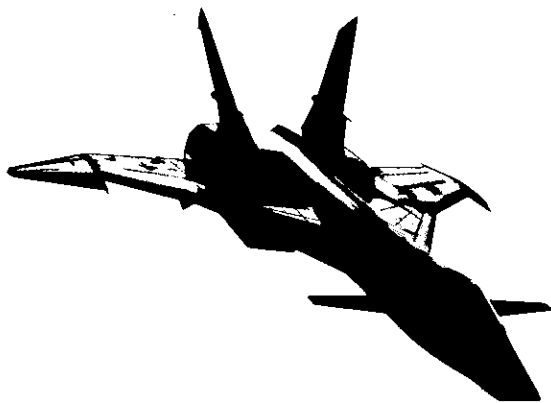

Description of Weapons

The FIREFOX pilot has some useful weapons at his disposal. He has bullets, guided missiles, and a "Heads Up" display.

You start each mission leg with unlimited bullets and four guided missiles under your wings. The missiles *are fired with the thumb buttons on the flight control*. When you fire a guided missile, you can guide it by moving the flight control. It will always move toward the crosshair. A missile will kill until its life is expired!

The "Heads Up" display is designed to communicate information to you quickly. This display includes the perimeter of the sight and the crosshair inside it. The horizontal red lines on either side of the crosshair show your fuel level. Each line represents three fuel units. Yellow rockets show you how many guided missiles you have left under your wings.

Scoring Information

When the Altitude Select screen appears, you get 10,000 bonus points if you were not detected. The screen will display either *10,000 BONUS* and *AVOIDED DETECTION* or *DETECTED*.

After you have landed, you get bonus points for

- finishing each leg of the mission (3000 points for each leg completed)
- fuel remaining (1000 points for each unit of fuel left)
- missiles remaining (1500 points for each missile left)

Hints for Game Play

- The amount of fuel you receive when you land depends upon the number of targets you've shot, so shoot all the targets you can!
- Use the "Heads Up" display to speed your passage through enemy territory.

- Use the guided missiles when the enemy is aggressively attacking you, because these missiles keep killing until they are spent.
- Fly in the sky to save fuel.
- You are not shot at if you're undetected, so be sly.
- You are not penalized for missed shots, so shoot like crazy at targets, and even shoot at things that aren't obvious, because you may destroy a secret object or camouflaged land base. These ground bases will shoot at you if you've been detected!

High-Score Mode

There are four tables to enter initials into—one table for each mission. There is an additional pilots' table that *all* pilots can enter their initials into, regardless of score.

Each table contains space for 60 pilots' initials. The table scrolls up and down depending on how you move the flight control.

If credits remain in the game, turn the flight control to the left to start the Select-A-Mission Mode. Turn the flight control to the right to view the High-Score Table.

A feature of the pilots' table is that it will not repeat initials (so the same person cannot fill up the entire table).

Self Test Mode

SelfTest is divided into two sections. The first section shows game statistics and allows the operator to reset certain statistics or change options with the use of the flight control. The second section is designed to allow checking of game switches, hardware failures, potentiometer adjustments, and video display adjustment. SelfTest may be entered any time during the Attract Mode. See Chapter 2 for complete Self Test information.

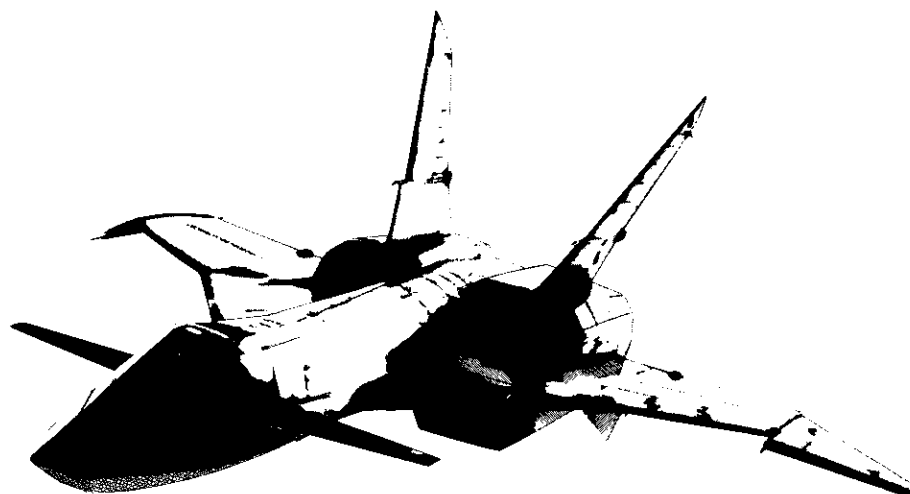

Self Test

This game will test itself and provide data to show that the game circuitry and controls are operating properly. Self-test data is presented visually on the video display and audibly through the speakers. No additional equipment is required.

We suggest you perform a self-test when you first set up, each time you collect money, change the game options, or suspect game failure.

NOTE

The self test procedures were unavailable for the first printing. See CO-253-02 for this information.

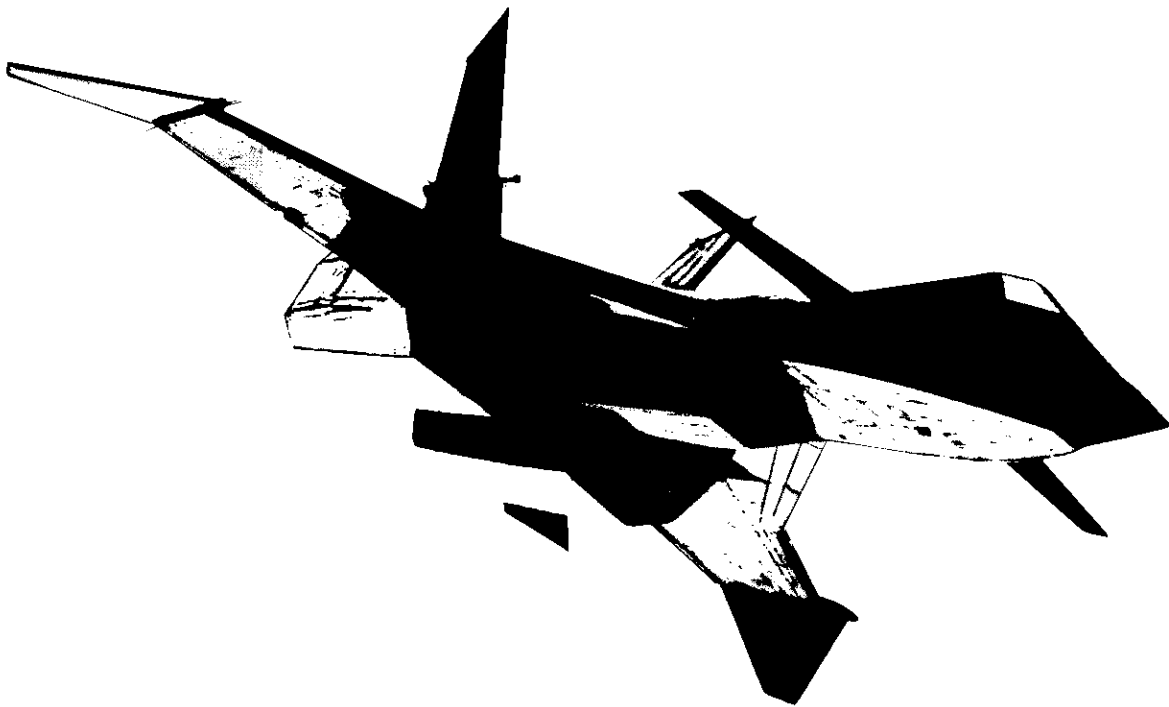

Maintenance

This chapter includes preventive and corrective maintenance procedures for those game components which are subjected to the most use. To assure the maximum trouble-free operation from this game, Atari recommends that periodic preventive maintenance be performed on the game components as described in this chapter.

Removal, disassembly, reassembly, and replacement procedures are provided for those components that may require corrective maintenance. Refer to the illustrated parts lists in Chapters 5, 6, or 7 of this manual to aid in locating the parts of this game that are mentioned in the maintenance procedures.

▲ — WARNING — ▲

To avoid possible electrical shock, unplug the game before performing any maintenance procedures.

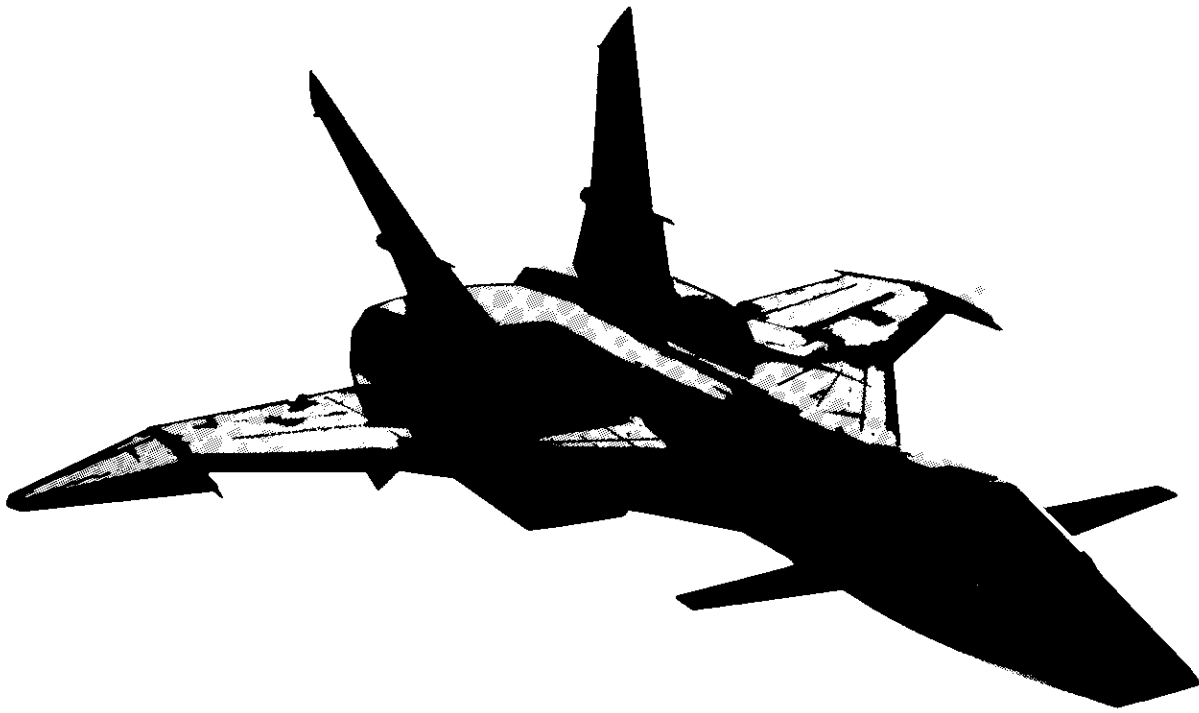

Preventive Maintenance

The following preventive maintenance procedures should be performed at regular intervals to assure maximum trouble-free operation from this game. Preventive maintenance includes cleaning, lubrication, and tightening of securing hardware. How often preventive maintenance is performed depends upon the game environment and frequency of play. However, the preventive maintenance intervals specified for the disc player and the flight control are minimum requirements for those components.

Removing the Control Panel

Perform the following procedure to remove the control panel:

1. Remove power from the game.
2. Unlock and remove the head and body access panels on the rear of the game cabinet.
3. Carefully reach through the back of the cabinet and release the spring-draw latches located under the control panel on either side of the game cabinet.
4. Lift the front of the control panel. Pull the panel up and tilt it toward you to clear the flight-control assembly.
5. Disconnect the flight-control harness before moving the control panel to a work surface.
6. To close the control panel, reconnect the flight-control harness.
7. Push the control panel back into place and gently set it down. Close the spring-draw latches.
8. Replace and lock the access panels. Apply power to the game.

Laser-Disc Player

The following preventive maintenance procedures apply to the disc player and its components.

Removing the Disc Player

1. Remove power from the game.
2. Remove the access panel of the pedestal assembly.
3. Release the draw latch on the disc player retaining strap.
4. Remove the retaining strap by lifting the front of the retaining strap and sliding it back to release it from the disc player.
5. Gently slide the disc player toward you until the wire and cable connections on the disc player's rear panel are accessible.

6. To open the disc-player lid, insert a small, flat-tipped (non-metallic) screwdriver (or similar tool) into the rectangular access hole just below the ridges on the disc-player cover. Gently press down on the small black lid-release mechanism.

CAUTION

Handle the laser disc only by its inside or outside edges. Do not touch the playing surface of the disc.

7. Carefully remove the laser disc from the disc player.

CAUTION

Do not leave the laser disc unprotected. Place it in a protective envelope and store it *vertically* in a cool, dry place.

8. Close the disc-player lid.
9. Disconnect the coaxial BNC connector and the two audio connectors from the back of the disc player.
10. Loosen the two attaching screws and disconnect the disc interface cable from the back of the disc player.
11. Remove the body access panel from the rear of the game cabinet and disconnect the disc player's power cord from the AC outlet located near the power on/off switch assembly.
12. Gently pull the power cord through the opening in the bottom of the body assembly.
13. Remove the disc player from the cabinet. Make certain the disc player power cord clears the cabinet.
14. After servicing the disc player, gently slide the disc player into the game cabinet.
15. Replace the retaining strap.
16. Replace and lock the access panels.
17. Apply power to the game.

Cleaning the Disc-Player Components

NOTE

Atari recommends that the disc player be returned to your distributor for major maintenance or repair. Perform the procedures under *Removing the Disc Player* and *Packing the Disc Player for Shipment* before shipping the disc player to your distributor.

Clean the dust filter behind the pedestal access panel, the laser disc, and the objective lens in the disc player at least twice a month as follows:

1. Remove power from the game.
2. Remove the pedestal access panel from the rear of the game cabinet.
3. Remove the dust filter from the back of the access panel by prying the edges of the retainer back with a flat-tipped screwdriver.
4. Clean the dust from the filter with a mild soap or detergent.
5. Dry the filter thoroughly and reinstall it on the access panel.
6. Remove the laser disc from the disc player as described in steps 2 through 7 of the *Removing the Disc Player* procedure.

CAUTION

Do not use any form of abrasive cleaner, alcohol, or solvent to clean the laser disc or objective lens of the disc player because permanent damage to the disc-playing surface or objective lens may result.

6. Clean the disc player objective lens with a non-abrasive, non-residue cleaner, such as Freon TF.
7. Clean the laser disc with a mild liquid detergent. Rinse with clean water and wipe dry with a lint-free, 100% cotton cloth.
8. With the playing surface of the disc facing downward, reinstall the disc in the disc player and press it gently onto the center spindle.
9. Close the lid of the disc player.
10. Gently slide the disc player into the game cabinet.
11. Replace the retaining strap.
12. Replace and lock the pedestal access panel.
13. Apply power to the game.

Packing the Disc Player for Shipment

Perform the following procedure before shipping the disc player:

1. Check the window in the lid of the disc player to make certain the laser disc has been removed before packing the disc player for shipment. If the laser disc is inside the disc player, remove the laser disc (follow steps 6 and 7 of *Removing the Disc Player*).
2. Seal the disc player in a plastic bag to provide moisture and dust protection during transit

3. Pack the sealed disc player in a sturdy shipping container large enough to allow at least three inches of space around the top, bottom, and sides of the disc player.
4. Pack at least three inches of loose or rigid foam (or an equivalent shock absorbent material) on the bottom of the container.
5. Place the disc player in the container and tightly pack all sides with packing material. Place enough packing material on the top of the disc player to hold the disc player firmly in place when the container is closed.
6. Seal the shipping container with an appropriate adhesive tape.

NOTE

If the disc player is to be shipped by common carrier, we suggest you insure the disc player for the replacement cost against loss or damage.

Flight Control

Preventive maintenance on the flight control includes lubricating the moving parts and checking for loose securing hardware at least every three months. The flight control consists of a handle assembly and a steering assembly. Preventive maintenance can be performed without removing the flight-control assembly from the the control panel.

Lubricating the Flight Control

Perform the following procedure to lubricate the flight control. Refer to Figures 3-1 and 3-2 for the location of the lubrication points and parts mentioned in the following procedure.

1. Remove the control panel as previously described.

NOTE

The handle-assembly cover is attached with tamper-proof socket screws. A special $\frac{3}{32}$ -inch hex-key tool is supplied with each game (Atari part no. 178126-001) to remove the tamper-proof socket screws.

2. Use the special $\frac{3}{32}$ -inch hex-key tool to remove the four tamper-proof socket screws from the handle assembly cover.
3. Lift the handle assembly off of the cover and lubricate the following parts inside the flight control.
 - a. Apply two drops of light machine oil lubricant (Atari part no. 107013-001) to the insides of the four shaft bearings.

- b. Brush a light film of Nyogel 779 lubricant (Atari part no. 178027-001) over the outside of the four torsion springs and on the teeth of the two small spur gears.

Tightening the Flight Control

Use the appropriate hex driver combination wrenches to tighten the flight control hex-head cap screws and mounting nuts. Refer to Figures 3-1 and 3-2 for an illustration of the cap screw and mounting nut locations.

Coin Mechanism

The coin mechanism should be cleaned periodically. A toothbrush may be used to remove any stubborn build-up of residue in the coin path. After cleaning the coin mechanism blow out all the dust with compressed air.

Game Cabinet and Display Shield

The game cabinet and display shield may be cleaned with any non-abrasive household cleaner. Compressed air is recommended for cleaning dust from the interior of the cabinet.

Corrective Maintenance

Corrective maintenance consists of removal, disassembly, reassembly, and replacement of game components. The following corrective maintenance procedures are provided for those components that may require corrective maintenance.

Flight Control

The following corrective maintenance procedures apply to the flight control. The flight control consists of a handle assembly and a steering assembly. The handle assembly controls the vertical motion and the steering assembly controls the horizontal motion of the display. After any corrective maintenance is performed, the flight control should be recalibrated as described in this chapter under *Calibrating the Flight Control*.

Removing the Handles

Perform the following procedure to remove the handles from the handle assembly (see Figure 3-1):

1. Use a $\frac{7}{64}$ -inch hex driver to remove the four cap screws that hold the covers on the handles. Be careful when removing the covers because the trigger and pushbutton springs can fall free from the handles.
2. Unsolder the three harness wires from the trigger and pushbutton microswitches inside each handle and pull the harness out of the shaft.
3. Use a $\frac{7}{64}$ -inch hex driver to remove the four cap screws that hold the handles to the shaft.
4. Use a $\frac{3}{16}$ -inch punch to knock the roll pin (located between the two cap screws) into the hollow of the shaft.
5. Gently slide the handles from the shaft.
6. To reinstall the handles, solder the three harness wires from the trigger and pushbutton microswitches.
7. Reinstall the roll pin.

8. Replace the trigger and pushbutton springs and reinstall the cap screws that hold the covers on the handles.
9. Reinstall the four cap screws that secure the handles to the shaft.

Removing the Flight-Control Assembly

NOTE

The handle assembly can be disassembled with the flight control attached to the control panel. However, for convenience and to avoid damaging the control panel, it is recommended that the flight control be removed from the control panel before any corrective maintenance or repair is performed.

Perform the following procedure to remove the flight control from the control panel:

1. Remove the control panel as previously described.
2. Disconnect the flight-control harness assembly.
3. Use $\frac{7}{64}$ -inch combination wrench to remove the four locknuts and washers that mount the flight control to the control panel.
4. Carefully guide the flight control through the hole in the control panel.
5. To reinstall the flight-control harness assembly, guide the flight control back into the control panel.
6. Reinstall the four locknuts and washers that mount the flight control to the control panel.
7. Reconnect the flight-control harness assembly.
8. Reinstall the control panel as previously described.

Disassembling the Handle Assembly

Perform the following procedure to disassemble the handle assembly (see Figure 3-1):

NOTE

It is not necessary to remove the handle assembly from the steering assembly to perform the following disassembly procedure. However, if you prefer, refer to steps 1 through 4 under *Disassembling the Steering Assembly* for the procedure that describes how to separate the two assemblies.

1. Use the special $\frac{3}{32}$ -inch hex-key tool to remove the four tamper-proof cap screws from the handle assembly cover.
2. Remove the handles as previously described.
3. Gently pull the harness wires out of the hollow shaft.
4. Use a $\frac{3}{16}$ -inch hex driver to remove the cap screw and washer that hold the spring-handle pin to the handle assembly shaft.
5. Slide the spring-handle pin out of the shaft.
6. Use a $\frac{3}{16}$ -inch hex driver to loosen the cap screw that holds the large spur gear to the shaft.
7. Slide the large (60-tooth) spur gear down the shaft to expose the shaft retainer on the right side.

WARNING

Shield your face and eyes when prying out the retainers because they can fly loose at a high velocity. Cover the retainers with a rag or any material that will trap the retainer.

8. Use a right-angle slotted screwdriver, or equivalent, to pry the retainer from the shaft.
9. Repeat step 8 to remove the retainer on the left side.
10. Gently slide the shaft from the housing.
11. Use a $\frac{3}{16}$ -inch hex driver to loosen the cap screw that holds the small (14-tooth) spur gear to the potentiometer shaft.
12. Use a $\frac{1}{2}$ -inch combination wrench to remove the nut and washer that hold the potentiometer to the mounting bracket.
13. Slide the potentiometer from the bracket. Be careful not to lose the small spur gear, nut, and washer.
14. Use a $\frac{3}{32}$ -inch hex-head and $\frac{3}{8}$ -inch combination wrench to remove the two bumpers from the frame.
15. Reassemble the handle assembly as described in the following procedure.

Reassembling the Handle Assembly

Perform the following procedure to reassemble the handle assembly (see Figure 3-1):

1. Use a $\frac{3}{32}$ -inch hex driver and $\frac{3}{8}$ -inch combination wrench to install the two bumpers on the frame.
2. Insert the large (60-tooth) spur gear with the collar facing away from the bearing. Align and hold the gear in line with the bearing hole. (The gear fits through the slot on the right front of the frame.)
3. Slide the shaft through the right-hand bearing and the spur gear. Do not insert the shaft past the outside edge of the spur-gear collar.
4. Apply a heavy film of Nyogel 779 lubricant (Atari part no. 178027-001) to the inside of the torsion spring.
5. Hook the straight end of the first torsion spring through the hole closest to the right side of the frame.
6. Hold the first torsion spring in line with the shaft so that the looped end of the spring is facing away from the spur gear.
7. Slide the shaft just through the first torsion spring.
8. Hook the straight end of the second torsion spring through the hole closest to the left-hand bearing.
9. Hold the second torsion spring in line with the shaft so that the looped end of the spring is facing the first torsion spring.
10. Slide the shaft through the second torsion spring and the left-hand bearing.
11. Position the shaft so that the retainer grooves are just inside the bearings.
12. Install the two retainers in the shaft grooves.
13. Turn the shaft so that the two large holes and the smaller centered hole are facing upward.
14. Locate the hole in the spring-handle pin. Insert the end of the spring-handle pin that is closest to the hole through the slot in the frame and through the hole in the shaft. Make sure both torsion spring looped ends are wrapped over the spring-handle pin.
15. Position the spring-handle pin so that the hole in the pin is aligned with the hole in the shaft.
16. Use a $\frac{3}{16}$ -inch hex driver to tighten the cap screw and washer that secure the pin to the shaft.
17. Align the cap screw in the spur-gear collar with the threaded hole in the shaft and use a $\frac{3}{16}$ -inch hex driver to tighten the cap screw.
18. Insert the potentiometer shaft through the hole in the mounting bracket. Before fully inserting the shaft through the bracket, place the washer, nut, and small (14-tooth) spur gear (with the collar facing inward) onto the shaft.

19. Align the potentiometer so that the tab key is inserted into the keying slot.
20. Use a ½-inch combination wrench to slightly tighten the nut on the potentiometer shaft.
21. Turn the potentiometer shaft so that the flat side faces the center wire terminal.
22. Align the cap screw on the small (14-tooth) spur gear with the flat side of the shaft, and use a ¼-inch hex driver to tighten the cap screw.
23. Slide the potentiometer forward so that the teeth on the two spur gears are tightly meshed; then slide the potentiometer and small (14-tooth) spur gear about ¼-inch away from the large spur gear.
24. Use a ½-inch combination wrench to tighten the potentiometer to the mounting bracket.
25. Perform the procedure under *Installing the Harness Assembly*.
26. Install the handles in the reverse order of the removal procedure previously described. Do not install the handle covers until the harness is installed and the proper wires are soldered to the trigger and pushbutton microswitches.
27. Check the vertical potentiometer alignment as described in this chapter under *Aligning the Potentiometers*.
28. Install the handle assembly cover and use a ⅜-inch hex-key tool to tighten the four tamper-proof socket screws that secure the cover to the handle assembly.

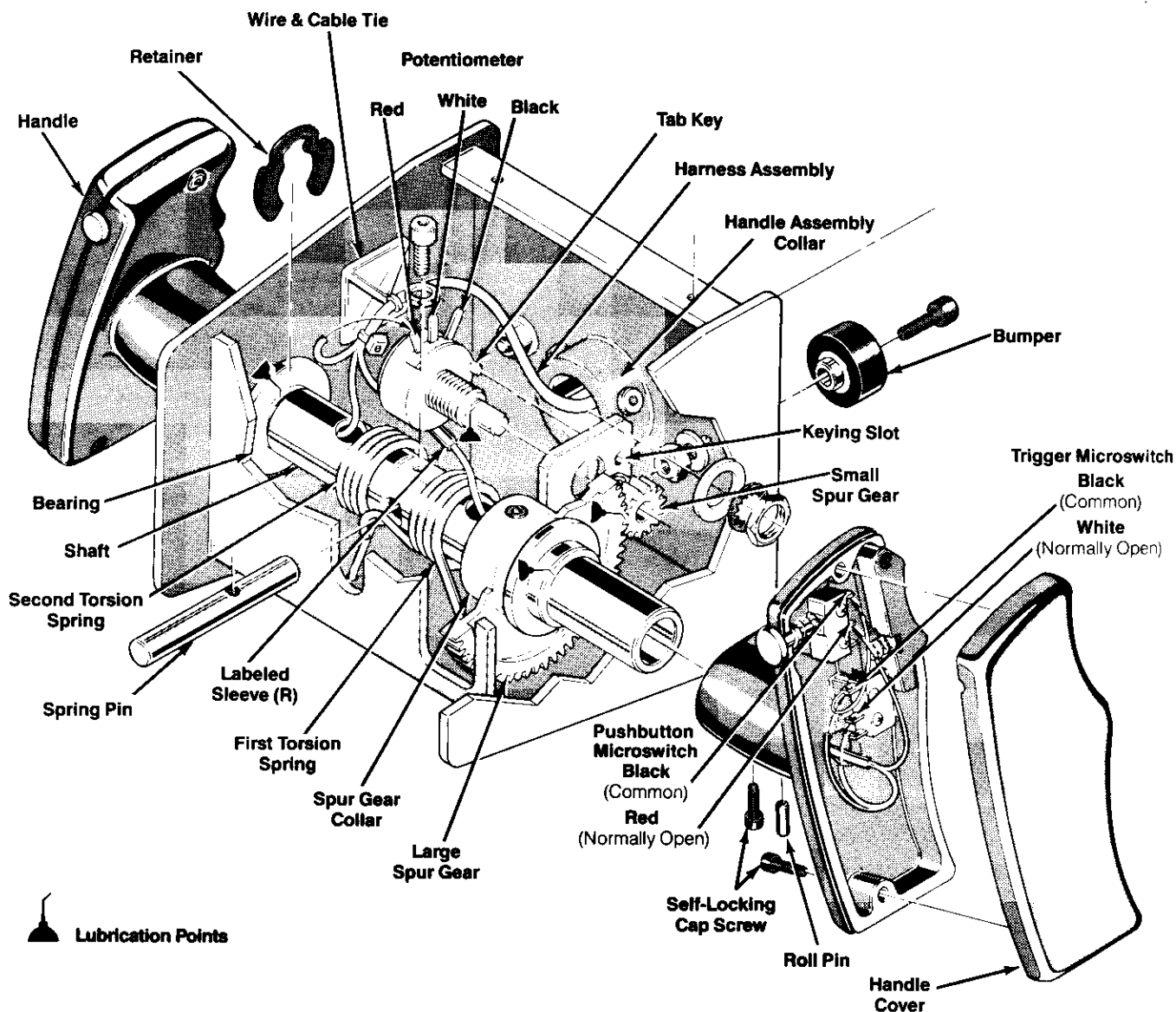

Figure 3-1 Handle Assembly

Disassembling the Steering Assembly

Perform the following procedure to disassemble the steering assembly (see Figure 3-2):

1. Remove the handle covers as described previously. Be careful when opening the handles since the pushbutton and trigger springs may fall out.
2. Unsolder the three harness wires from the vertical potentiometer and the handle pushbutton and trigger microswitches.
3. Use a $\frac{3}{4}$ -inch hex (or ball-end) driver to remove the three cap screws that hold the steering-assembly shaft to the handle-assembly frame.
4. Gently pull the two assemblies apart. Make sure the harness wires are free to slide out of the handle-assembly shaft.
5. Use a $\frac{5}{16}$ -inch wrench to remove the anchor nut on the end of the anchor pin. (The anchor nut faces the open end of the frame.)
6. Slide the anchor pin from the shaft.
7. Grasp the large (60-tooth) spur gear and slide the shaft from the frame. The bearing spacer and torsion springs will fall free.
8. Use a $\frac{3}{4}$ -inch hex driver to remove the cap screws that hold the large spur gear to the steering shaft and the small spur gear to the potentiometer shaft.
9. Use a $\frac{1}{2}$ -inch combination wrench to remove the nut and washer that hold the potentiometer to the frame.
10. Unsolder the three harness wires from the potentiometer terminals.
11. Use a slotted screwdriver, or equivalent, to remove the retainer from the shaft.
12. Use a $\frac{5}{32}$ -inch hex driver and $\frac{3}{8}$ -inch combination wrench to remove the two bumpers from the frame.
13. Reassemble the steering assembly as described in the following procedure.

WARNING

Shield your face and eyes when prying the retainer from the shaft because the retainer can fly loose at a high speed. Cover the retainer with a rag or any material that will trap the retainer.

Reassembling the Steering Assembly

Perform the following procedure to reassemble the steering assembly (see Figure 3-2):

1. Use a $\frac{5}{32}$ -inch hex driver and $\frac{3}{8}$ -inch combination wrench to install the two bumpers to the frame.

2. Snap the retainer into the groove of the shaft and slide the large, flat washer down the long end of the shaft and against the retainer.
3. Apply a heavy film of Nyogel 779 lubricant (Atari part no. 178027-001) to the inside of the torsion springs.
4. Hook the straight end of the first torsion spring through the hole closest to the back of the frame. Slide the shaft through the outside bearing and the first torsion spring.
5. Hook the second torsion spring through the hole on the opposite side and closest to the front of the frame. Slide the shaft through the second spring and the opposite bearing.
6. Turn the shaft so that the threaded hole at the retainer end of the shaft faces up toward the open side of the frame. (The hole through the center of the shaft will then be perpendicular to the open side of the frame.)
7. Use a $\frac{5}{16}$ -inch combination wrench to install the anchor pin and nut through the hole in the center of the shaft. Make sure the torsion spring looped ends are wrapped under the anchor pin and nut.
8. Slide the large (60-tooth) spur gear onto the shaft with the collar facing out.
9. Align the cap screw in the spur-gear collar with the threaded hole in the shaft, and use a $\frac{3}{4}$ -inch hex driver to tighten the cap screw.
10. Insert the potentiometer shaft through the hole in the frame and align the potentiometer so that the tab key is inserted into the keying slot.
11. Install the washer and nut on the potentiometer shaft, but do not tighten.
12. Turn the potentiometer shaft so that the flat side faces the center wire terminal.
13. Align the cap screw on the small (28-tooth) spur gear with the flat side of the shaft and slide the small spur gear (with the collar facing inward) onto the potentiometer shaft.
14. Position the spur gear so that its teeth mesh with those of the large spur gear and use a $\frac{3}{4}$ -inch hex driver to tighten the cap screw.
15. Slide the potentiometer forward so that the teeth on the two spur gears are tightly meshed; then slide the potentiometer and small spur gear about $\frac{1}{4}$ -inch away from the large spur gear.
16. Use a $\frac{1}{2}$ -inch combination wrench to tighten the potentiometer to the frame.
17. Slide the bearing spacer over the shaft at the end opposite the spur gears. Check to make sure that the deep side of the bearing spacer sits over the head of the bronze flange bearing in the steering-assembly frame.
18. If necessary, lubricate the steering assembly as previously described.

NOTE

The remaining steps describe the procedure for attaching the steering assembly to the handle assembly.

19. Insert the steering-assembly shaft into the collar on the handle-assembly frame.
20. Align the three holes in the steering-assembly shaft with the three holes in the handle-assembly collar.
21. Use a $\frac{3}{64}$ -inch hex (or ball-end) driver to tighten the three cap screws. Make sure these screws are tight.
22. Install the harness assembly as described in the following procedure.
23. Check the horizontal potentiometer alignment as described under *Aligning the Potentiometers*.

Installing the Harness Assembly

Perform the following procedure to install the harness assembly to the flight control (see Figures 3-1 and 3-2):

1. If necessary remove the handle covers as described under *Removing the Handles*.
2. Guide the harness wires into the spur-gear end of the hollow steering assembly shaft.
3. Route and solder the wires to the potentiometers and microswitches. Note that the wire bundle that goes to the right handle is identified with a labeled sleeve (R).
4. Install the wire ties and the ground clip. Make sure the wires do not interfere with the gears when the flight-control assembly is mounted.

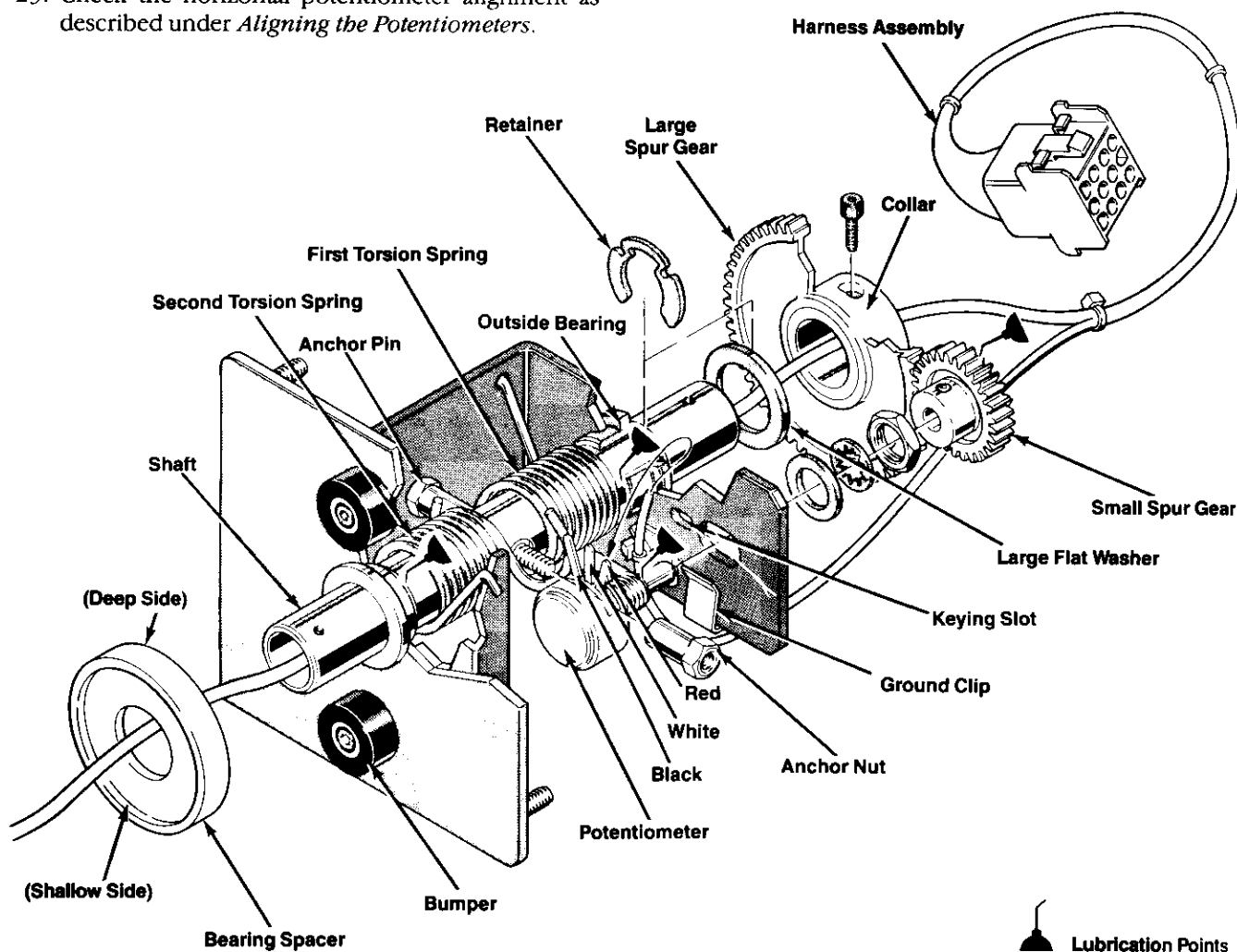

Figure 3-2 Steering Assembly

Aligning the Potentiometers

The following procedures describe the method for checking and aligning the vertical and horizontal flight-control potentiometers to ensure that the target cursor on the display is centered when the flight control is released.

Vertical Potentiometer Alignment

Perform the following procedure to align the flight-control vertical potentiometer (see Figure 3-1):

1. If necessary, remove the flight-control handle assembly cover with the special $\frac{3}{32}$ -inch hex-key tool to gain access to the vertical motion potentiometer.
2. With the flight control centered (no tension on the return springs), check that the set screw on the potentiometer spur gear is facing the center (white) wire terminal. If not, use a $\frac{1}{2}$ -inch combination wrench and loosen the potentiometer mounting nut. Slide the potentiometer sideways in the mounting bracket until the gears disengage.
3. Turn the small spur gear until the displayed target cursor is centered vertically.
4. Gently slide the potentiometer forward so that the spur gear teeth are tightly meshed (if necessary, move the large gear slightly to align the gear teeth—do not turn the potentiometer shaft). Recheck the display target cursor to make certain the potentiometer alignment is still correct. If not, repeat steps 2 and 3.
5. Pull the potentiometer and small spur gear away from the large spur gear about $\frac{3}{4}$ -inch and use the $\frac{1}{2}$ -inch combination wrench to tighten the potentiometer to the mounting bracket.
6. Install the handle-assembly cover by using the special $\frac{3}{32}$ -inch hex-key tool to tighten the tamper-proof socket screws.

Horizontal Potentiometer Alignment

Perform the following procedure to align the horizontal potentiometer (see Figure 3-2):

1. Open the control panel as described previously in this chapter.
2. With the flight control centered (no tension on the springs), check that the set screw on the potentiometer spur gear is facing the center (white) wire terminal. If not, use a $\frac{3}{32}$ -inch hex driver and loosen the set screw on the potentiometer spur gear. Slide the spur gear off the potentiometer shaft.
3. Turn the potentiometer shaft until the displayed target cursor is centered horizontally.
4. Slide the spur gear onto the potentiometer with the set screw centered over the flat side of the shaft while aligning the gear teeth so they mesh with the large

spur gear (if necessary, the small spur gear can be turned slightly—do not turn the potentiometer shaft).

5. Use the $\frac{3}{32}$ -inch hex driver and tighten the spur-gear set screw. Recheck the displayed target cursor to make certain the potentiometer alignment is still correct. If not, repeat parts 2 through 4.

Calibrating the Flight Control

The flight control is self-calibrating. The game circuitry monitors the position of the target cursor on the display in relation to the flight control vertical and horizontal position. Calibrate the flight control after any corrective maintenance is performed by moving the target cursor to all four extreme edges of the display. Calibration is also accomplished during normal game play, but may take several seconds of game play to optimize. If the target cursor on the display fails to return to center screen when the flight control is released, check the flight control vertical and horizontal alignment as previously described.

Removing the CRT Assembly

WARNING

High Voltage

This display contains high voltages capable of delivering lethal amounts of energy. To avoid danger, do not attempt to service the display until you have observed all precautions necessary for working on high-voltage equipment.

X-Radiation

This display was designed for minimum X-radiation hazard. However, to avoid possible exposure to soft X-radiation, never modify the high-voltage circuitry.

Implosion Hazard

The cathode-ray tube assembly may implode if struck or dropped. Shattered glass may cause personal injury within a 6-foot radius. To reduce the risks of injury to people or of damage to the game components, we recommend that two people perform the following removal procedures.

Perform the following procedure to remove the cathode-ray tube (CRT) assembly from the game:

1. Use a Phillips-head screwdriver to remove hardware that secures the head access panel to the game cabinet.
2. Discharge the high-voltage from the CRT before proceeding. The video display contains a circuit for discharging the CRT high voltage to ground when

power is removed. However, to make certain, always discharge the CRT as follows:

- a. Attach one end of a large, well insulated, 18-gauge jumper wire to ground.
 - b. Momentarily touch the free end of the grounded jumper to the anode by sliding it under the anode cap.
 - c. Wait two minutes and repeat part b.
3. Disconnect the CRT neck-pin connector, anode lead, yoke connector, degaussing coil connector, and the 1-pin DAG spring connector (see Figure 3-3).
 4. Follow steps 2 through 8 under *Removing the Light and Speaker Board Assembly* in this chapter.

▲ WARNING ▲

Be extremely careful when removing the cathode-ray tube mounting bolts because the cathode-ray tube assembly can fall. We recommend that a second person **carefully** hold the cathode-ray tube neck while the mounting bolts are being removed.

5. Use a ¼-inch combination wrench to remove the bolts and washers from the front of the display mounting bracket.
6. Carefully lift the CRT assembly from the front of the cabinet.
7. Replace the CRT in reverse order.

NOTE

Whenever the cathode-ray tube is replaced, readjust the brightness, purity, and convergence as described in the display manual.

Removing the Tube and Speaker Board Assembly

Perform the following procedure to remove the tube and speaker board assembly from the game (see Figure 3-3):

1. Use a Phillips-head screwdriver to remove the display access panel from the rear of the game cabinet.
2. Disconnect the harnesses from the fluorescent tube assembly and from the speakers.
3. From the front of the cabinet, use an Allen wrench to remove the hardware from the upper retainer of the attraction panel. Save this hardware for reassembly.
4. Slide both the attraction panel and the semi-rigid film that is behind the panel up and out of the left and right retainers.

NOTE

A molding is firmly fitted on each side of the attraction panel and on each side of the display shield. These moldings should stay on these parts when you remove them.

5. Remove the H-shaped retainer between the attraction shield and the display shield.
6. Slide the display shield up and out of the right and left retainers. If necessary, loosen the lower retainer to break the foam tape seal on the bottom of the display shield.
7. Carefully remove the display bezel.
8. Remove the four screws securing the right and left retainers to the cabinet.
9. Remove the two screws that secure the cleat at the top of the display shelf.
10. Pull the fluorescent tube and speaker board assembly out of the front of the cabinet.

Replacing the Speakers

Perform the following procedure to replace the speakers:

1. Remove the fluorescent tube and speaker board assembly as previously described.
2. With the fluorescent tube and speaker board assembly out of the cabinet, disconnect the two snap-on connectors from each speaker.
3. Remove the hardware securing each speaker grille to the tube and speaker board.
4. Remove the hardware that secures each speaker to its grille/bracket.
5. Mount each new speaker to its grille/bracket with the appropriate hardware.
6. Mount each grille/bracket to the tube and speaker board.
7. Reconnect the two snap-on connectors to each speaker.

Replacing the Fluorescent Tube and Speaker Board Assembly

1. Carefully slide the fluorescent tube and speaker board assembly into the upper front of the cabinet.
2. Replace the screws securing the cleat to the top of the display shelf.
3. Replace the right and left retainers.
4. Slide the bottom edge of the display bezel into the lower retainer. Press the right and left tabs of the bezel behind (not in) the slots in the right and left retainers. The top tab rests against the front edge of the fluorescent tube and speaker board assembly.

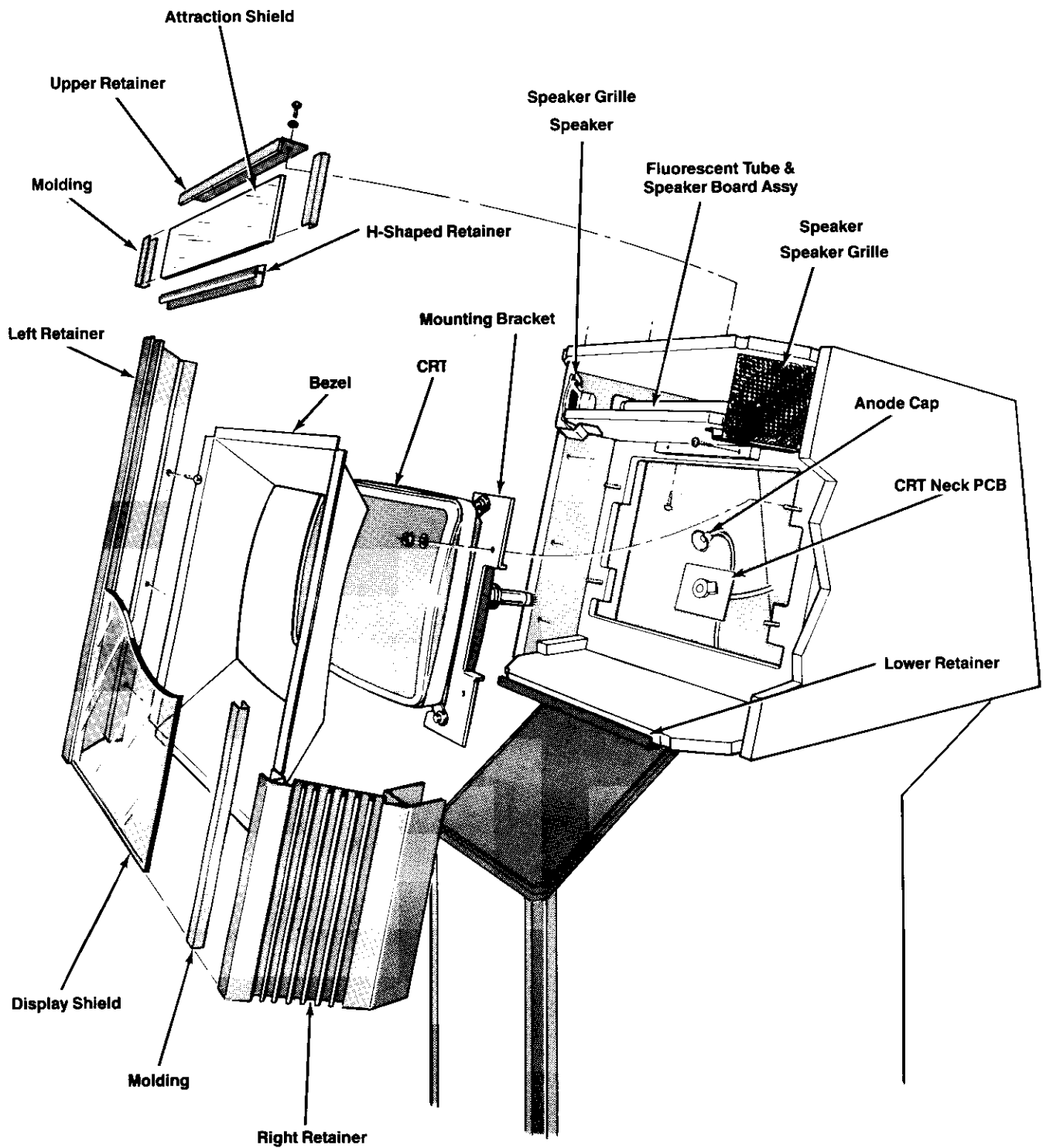

Figure 3-3 Fluorescent Tube and Speaker Board Removal and Display Access and Removal

5. Replace the display shield (with the moldings attached) by sliding it into the slots of the right and left retainers on either side of the display.
6. Tighten the lower retainer.
7. Slide the H-shaped retainer onto the top edge of the display shield.
8. Slide the attraction panel and semi-rigid film (with the moldings attached) into the right and left retainer slots. Make certain the bottom edge of the attraction panel and semi-rigid film is inserted completely into the H-shaped retainer slot.
9. Use an Allen wrench to replace the hardware that secures the upper retainer of the attraction panel.
10. From the back of the cabinet, reconnect the 3-pin connector from the fluorescent tube harness and the 4-pin connector from the speakers.
11. Use a Phillips-head screwdriver to replace the hardware that secures the head access panel to the cabinet.

Removing the Lower Speakers

The control panel must be removed as previously described for access to the lower speakers. Reach into the game cabinet from the front and disconnect the speaker harness and the two snap-on connectors. Remove the screws securing the speakers to the cabinet. The lower speaker grille is riveted to the cabinet and is not removable.

Troubleshooting

This chapter contains a discussion of troubleshooting aids and techniques to assist the service technician when a trouble is suspected in this game. Most troubles can be located quickly by following the information in this chapter. However, if problems persist, contact your nearest Atari Customer Service office listed on the inside front cover of this manual for assistance.

A thorough knowledge of game operation is desirable for effective troubleshooting. In addition to the operation and service information in the Schematic Package Supplement included with this manual, refer to *The Book, A Guide To Electronic Game Operation and Servicing*, this publication is available from Atari, Inc., and has more information on coin-operated electronic games.

NOTE

We recommend that troubleshooting and repair procedures be performed by a qualified electronic technician.

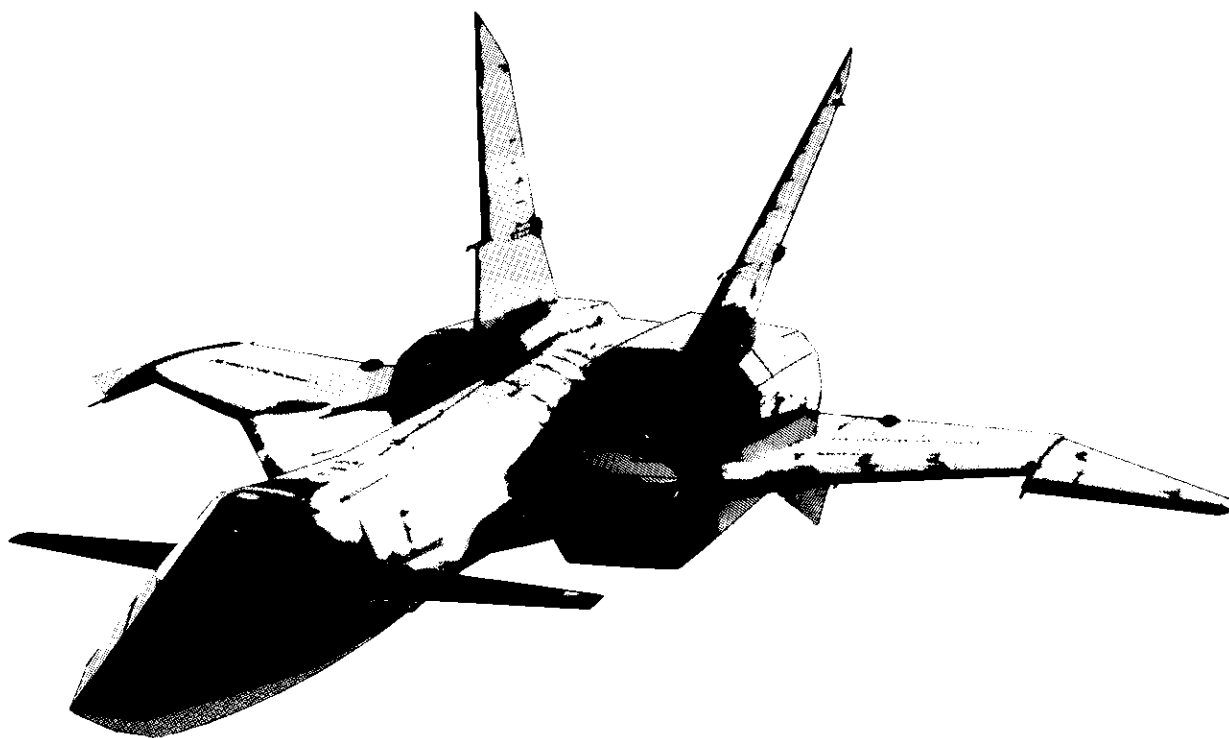

Troubleshooting Aids

NOTE

Atari recommends that the disc player be returned to your distributor for major maintenance or repair. Refer to the *Removing Disc the Player* and the *Packing the Disc Player for Shipment* procedures in Chapter 3 before shipping the disc player to your distributor.

Troubleshooting aids are provided throughout this manual and the Schematic Package Supplement. The following information is intended to acquaint the service technician with the portions of these documents that contain useful troubleshooting and repair information

Assembly and Component Locations

The parts lists in Chapters 5, 6, and 7 illustrate the locations of assemblies and components. Printed-circuit board (PCB) illustrations aid in rapidly locating components shown on the corresponding schematic diagram(s).

Diagrams

The Schematic Package Supplement included with this game contains schematic diagrams with component locations, active component type numbers, and electrical values.

Troubleshooting Procedures

Refer to the following section, *Troubleshooting Techniques*, for a suggested troubleshooting sequence to aid in locating defective components.

Troubleshooting Techniques

WARNING

To avoid electrical shock, turn off the game power before attempting to troubleshoot this game.

The following troubleshooting steps are arranged in a sequence recommended for locating a defective component. The procedure begins with a check of the simple trouble possibilities and progresses to more extensive procedures for localizing the problem to an assembly or major circuit, and then to a defective component.

Check Switch Settings

Incorrect switch settings can sometimes indicate a problem that does not exist. Refer to Chapter 1 to verify that the

game has been installed properly and that the switches are set to their correct positions. Check for proper operation in all game play modes.

Check Fuses

Check for open fuses. Refer to the Power Supply Manual and to the Display Manual for the location and rating of each fuse used in this game. Make sure that replacement fuses are the proper type and rating.

Check Power-Supply Voltages

Improper operation of all circuits usually indicates a power supply problem. Be sure that the proper line voltage is available to the power supply. Check for correct voltages.

Localize Trouble

Determine the trouble symptom. Use the wiring diagrams in the Schematic Package Supplement to determine which assemblies or major circuits could cause the trouble. Perform the self-test procedure provided in Chapter 2.

Visual Check

Visually check for obvious problems in the portion of the game where the trouble is suspected. For example, check for loose or defective solder connections, integrated circuits loose in their sockets, loose cable connections, broken wires, and damaged PCBs or components.

Check Individual Components

Check soldered-in passive components (e.g., resistors, capacitors, diodes) by disconnecting one end to isolate the measurement from the effects of the surrounding circuitry. Often, direct substitution is the most practical way to determine if a component is faulty. However, eliminate the possibility of some other circuit problem that could damage the substitute component.

Repair the Assembly

CAUTION

Soldered-in transistors and integrated circuits are difficult to remove without damaging the printed-circuit board or component. Refer to the information in this chapter pertaining to soldering and replacing integrated circuits and transistors.

Repair or replace the defective part. Refer to Chapter 3 and information in this chapter for special removal and replacement procedures. Check for proper operation of the repaired circuit.

Soldering Techniques

Observe the following recommendations when removing or replacing components soldered to a PCB. Poor soldering practices can damage a PCB or heat-sensitive electrical components.

Choosing the proper soldering iron is essential before attempting to remove or replace soldered-in components. Excessive heat is a common cause of damage to a component or PCB. However, transient voltages from solder guns or improperly grounded soldering irons can also damage certain voltage-sensitive semiconductor devices. Refer to *Troubleshooting Static-Sensitive Devices* for more specific information.

A 15- to 27-watt pencil-tip soldering iron is recommended to avoid separating the etched circuit wiring from the board material and to avoid damaging active components. A temperature-controlled soldering station rated at 700°F with a fine cone or a very fine chisel tip can also be used.

CAUTION

Solder guns are not recommended for removing or replacing soldered-in components on a printed-circuit board. The added possibility for overheating and the large transient voltage induced by the solder gun could cause damage to heat or voltage-sensitive devices.

The following additional equipment is recommended for removing and replacing soldered-in components.

- Solder Sucker—Hand-operated vacuum tool used to remove liquified solder from the PCB. Top-of-the-line Soldapull® brand is recommended.
- Solder Wick—Resin-soaked copper braid used for removing excess solder from the lead connections on the PCB. See *Removing Integrated Circuits* for precautions relating to the use of a solder wick on a multi-layer PCB with plated-through holes.
- Flux Remover—Non-corrosive chemical used to clean foreign material from the PCB before soldering and to remove any flux residue where components have been replaced. Also used to clean any foreign material from the PCB during preventive maintenance. Isopropyl alcohol is recommended.
- Acid Brush—Small stiff-bristled paint or toothbrush used with flux remover to clean flux and other foreign material from the PCB.

Removing Integrated Circuits

The easiest and safest method for removing soldered-in integrated circuits (IC) from a PCB is to cut off each pin as close to the IC case as possible with a tip dyke (diagonal cutter) as shown in Figure 4-1.

Use the proper soldering iron as previously described under *Soldering Techniques*. Then, to avoid excessive heat buildup in one area of the PCB, apply heat directly to each pin in a random order. Remove the loosened pin with the tip of the soldering iron or a needle-nose pliers as shown in Figure 4-2. Allow a moment for the PCB to cool before proceeding to the next pin. Apply just enough heat to remove any stubborn pins.

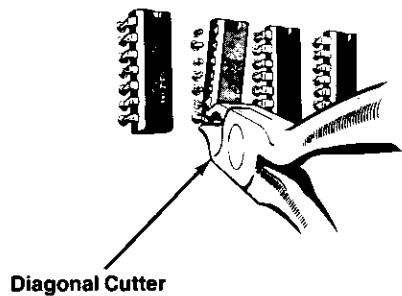

Figure 4-1 Removing ICs (Cut Pin Method)

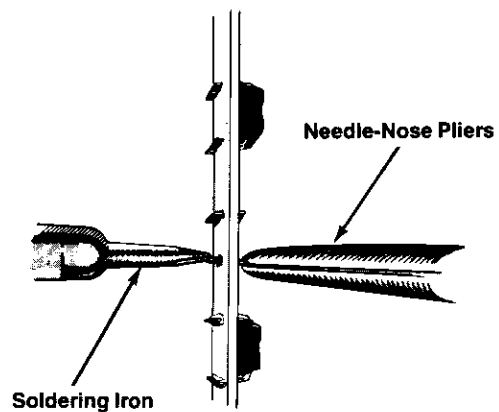

Figure 4-2 Removing IC Pins

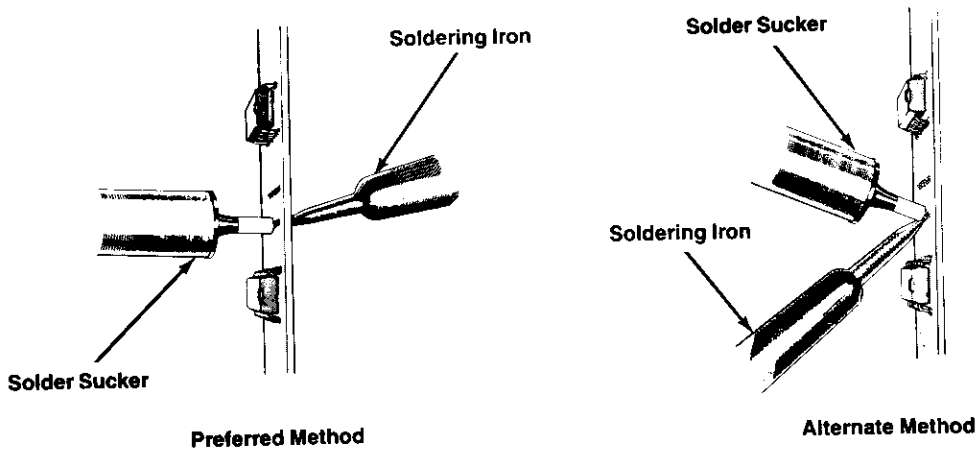

Figure 4-3 Removing Solder from Plated-Through Holes

For a multi-layer PCB with plated-through holes, use a solder sucker to remove the remaining solder from inside each hole as shown in Figure 4-3. If possible, suck the solder from the opposite side of the PCB from where the heat is applied.

Use a solder wick to remove excess solder from around the lead connection pads on the top and/or bottom surface of the PCB as shown in Figure 4-4.

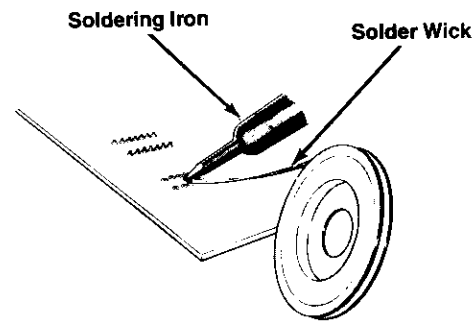

Figure 4-4 Removing Solder from Lead Connection Pads

CAUTION
Do not use a solder wick to remove solder from inside plated-through holes. The heat required for the solder wick to remove the solder from inside the hole could damage the PCB.

Troubleshooting Static-Sensitive Devices

Certain precautions must be taken when working with static-sensitive devices, e.g., microprocessors, field-effect transistors (FET), complementary metal-oxide semiconductors (CMOS), and other large-scale integration (LSI) devices that use metal-oxide semiconductor (MOS) technology. Static charge buildup in a person's body or leakage from an improperly grounded soldering iron can cause static-sensitive device failure.

Before handling a static-sensitive device or a PCB with such devices attached to it, ground any static voltage that may have accumulated in your body by touching an object that has been earth grounded. A bare wire wrapped around your wrist and attached to an earth ground is effective when working extensively with static-sensitive

devices. When soldering on a static-sensitive device, use a soldering iron with a properly grounded three-wire cord. (Refer to *Soldering Techniques* for a discussion of recommended soldering irons and procedures.)

A static-sensitive device may appear defective due to leakage on a PCB. Observe the precautions for grounding static voltages described in the preceding paragraph and clean both sides of the PCB with flux remover or an eraser before replacing what may be a good static-sensitive device. For discrete FETs, clean thoroughly between the gate, drain, and source leads.

Static-sensitive devices may be packaged in conductive foam or have a protective shorting wire attached to the pins. Remove the conductive foam just prior to inserting the device in its socket or soldering to a PCB. Remove the shorting wire only *after* the device is inserted in its socket or *after* all the leads are soldered in place.

Illustrated Parts Lists

This chapter provides information you need to order parts that are common to both FIREFOX games (Upright and Sit-Down). Refer to Chapter 6 for Upright cabinet parts lists, and Chapter 7 for Sit-Down cabinet parts lists.

Common hardware (screws, nuts, washers, etc.) has been deleted from most of the parts lists. However, a parts list is included for hardware that mounts the components to the cabinets.

The PCB parts lists are arranged in alphabetical order by component. Each component subsection is arranged alphanumerically by reference designator.

Other parts lists are arranged alphanumerically by Atari part number. In these parts lists, all A-prefix numbers come first. Following these are numbers in sequence evaluated up to the hyphen, namely 00- through 99-, then 000598-through approximately 201000-.

When ordering parts, please give the part number, part name, number of this manual, and serial number of your game. This will aid in filling your order rapidly and correctly. We hope the results will be less downtime and more profit from your game.

Atari Customer Service numbers are listed on the inside front cover of this manual.

Wherever a static-sensitive device appears in a PCB parts list, this symbol appears: ▲



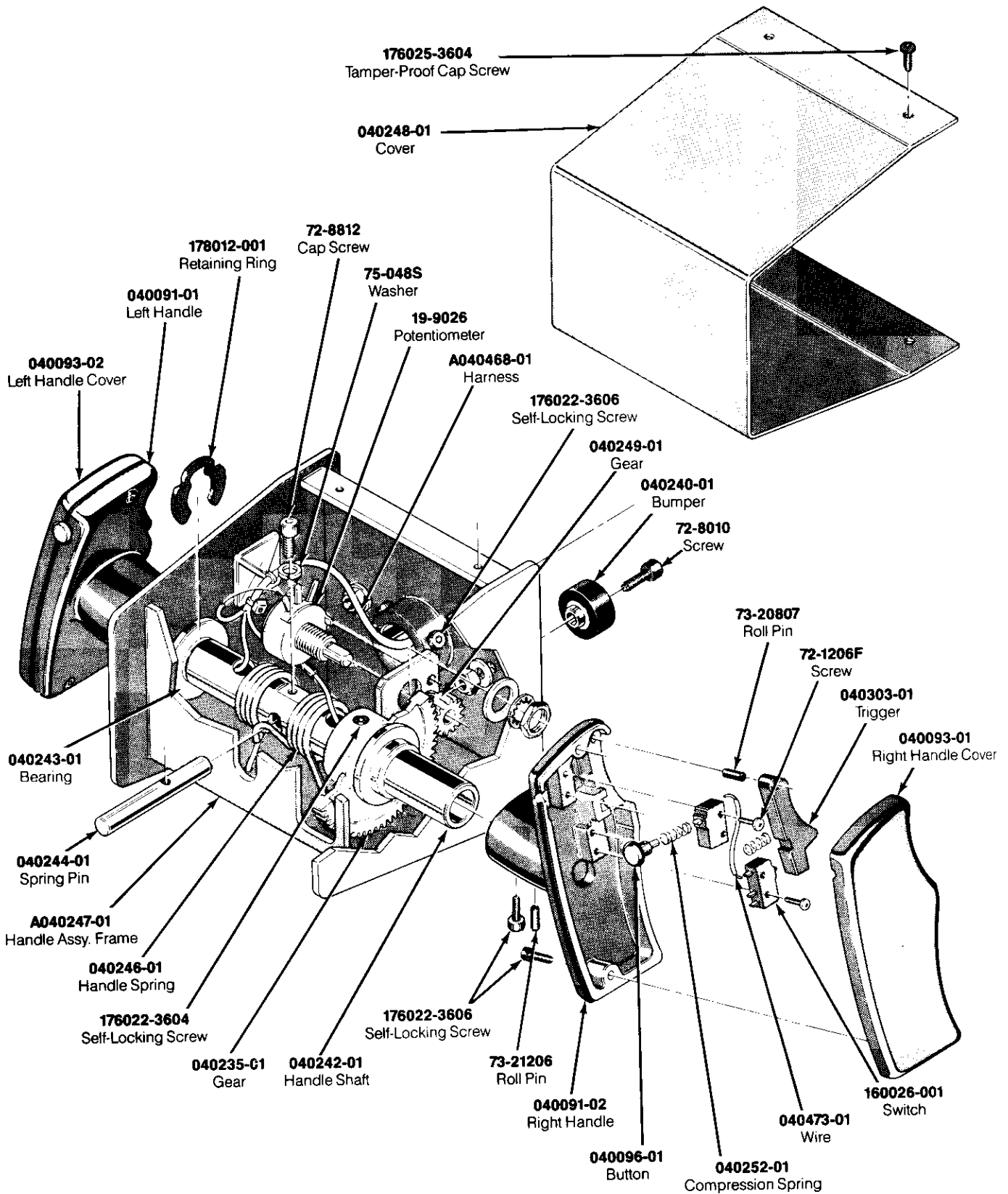

**Figure 5-1 Flight Control Assembly
A040233-02 G**

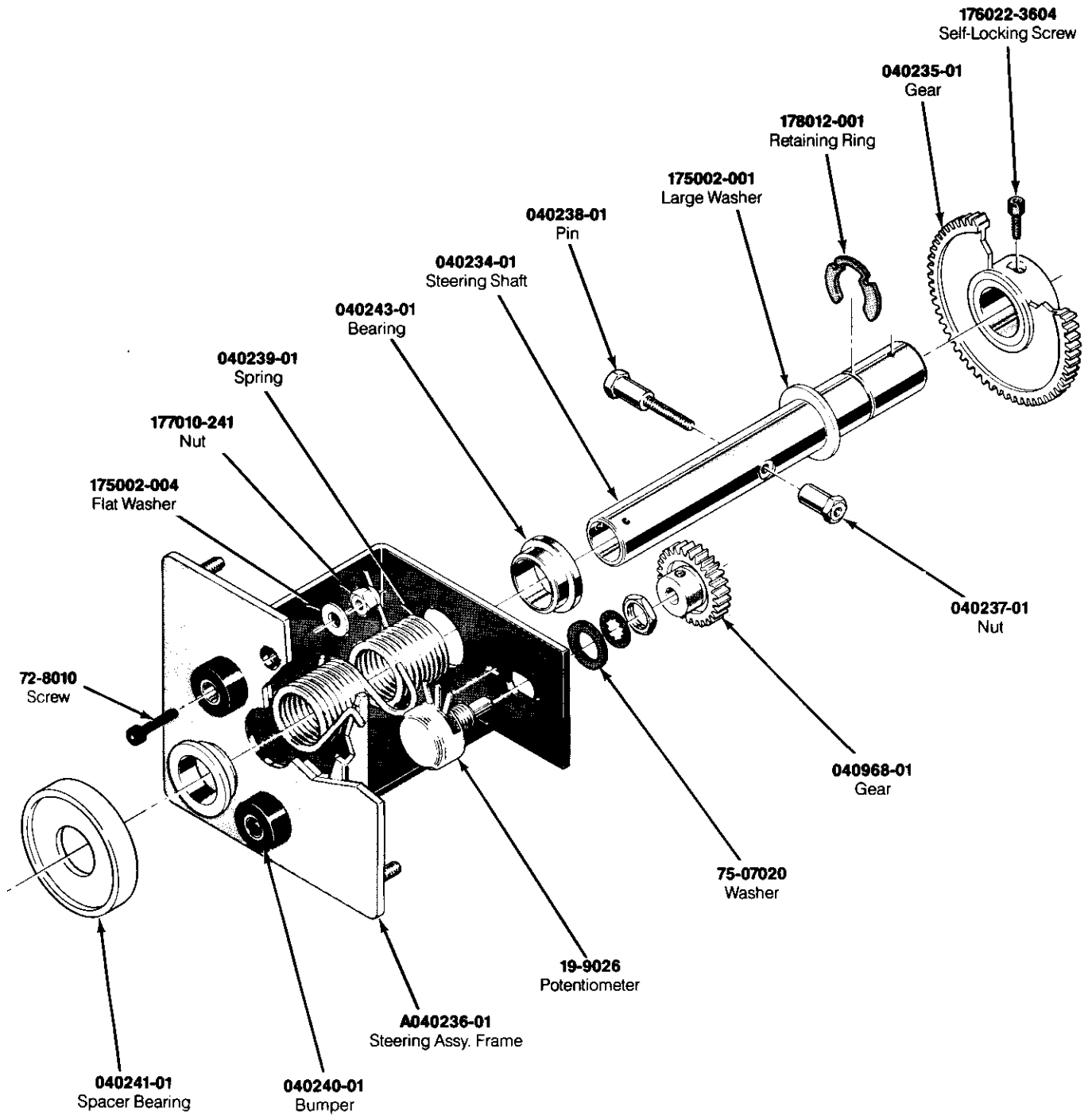

See Chapter 3 for lubrication information

Figure 5-1 Flight Control Assembly, continued
A040233-02 G

Flight Control Assembly Parts List

Part No.	Description
A040236-01	Steering Assembly Frame—includes:
040243-01	Modified Bearing
040555-01	Steering Frame Weldment
72-L2S510	# $\frac{1}{4}$ -20 × $\frac{3}{8}$ -Inch Long Self-Clinching Stud
A040247-01	Handle Assembly Frame—includes:
040243-01	Modified Bearing
040556-01	Frame Handle Weldment
A040468-01	Flight Control Harness Assembly
19-9026	5 k Ω Potentiometer
72-1206F	#2-56 × $\frac{3}{8}$ -Inch Cross-Recessed Pan-Head Machine Screw
72-8010	#10-32 × $\frac{3}{8}$ -Inch Socket-Head Cap Screw
72-8812	#8-32 × $\frac{3}{4}$ -Inch Socket-Head Cap Screw
73-20807	$\frac{3}{8}$ -Inch Diameter × $\frac{7}{16}$ -Inch Long Spring Roll Pin
73-21206	Roll Pin
75-040S	#10 Split-Lock Washer (not shown)
75-048S	#8 Split-Lock Washer
75-07020	0.390-Inch I. D. Flat Washer
040091-02	Right Handle
040091-01	Left Handle
040093-01	Right Handle Cover
040093-02	Left Handle Cover
040096-01	Button
040234-01	Steering Shaft
040235-01	60-Tooth Spur Gear
040237-01	Anchor Nut
040238-01	Anchor Pin
040239-01	Steering Torsion Spring
040240-01	Stop Bumper
040241-01	Spacer Bearing
040242-01	Handle Shaft
040244-01	Spring Handle Pin
040246-01	Handle Torsion Spring
040248-01	Cover
040249-01	14-Tooth Spur Gear
040252-01	Compression Spring
040303-01	Trigger
040473-01	Jumper Wire
040968-01	28-Tooth Spur Gear
160026-001	SPDT Snap Switch
175002-001	0.750-Inch I. D. Large Washer
175002-004	#10 Flat Washer
176008-106	#10-32 × $\frac{3}{8}$ -Inch Self-Locking Socket-Head Cap Screw (not shown)
176022-3604	#6-32 × $\frac{1}{4}$ -Inch Self-Locking Socket-Head Cap Screw
176022-3606	#6-32 × $\frac{3}{8}$ -Inch Tamper-Proof Socket-Head Cap Screw
176025-3604	#6-32 × $\frac{1}{4}$ -Inch Tamper-Proof, Self-Locking, Button-Head Cap Screw
176026-3610	#6-32 × $\frac{3}{8}$ -Inch Tamper-Proof Socket-Head Cap Screw
177010-241	#10-32 Nylock Hex Nut
178012-001	Retaining Ring for .750-Inch Diameter Shaft

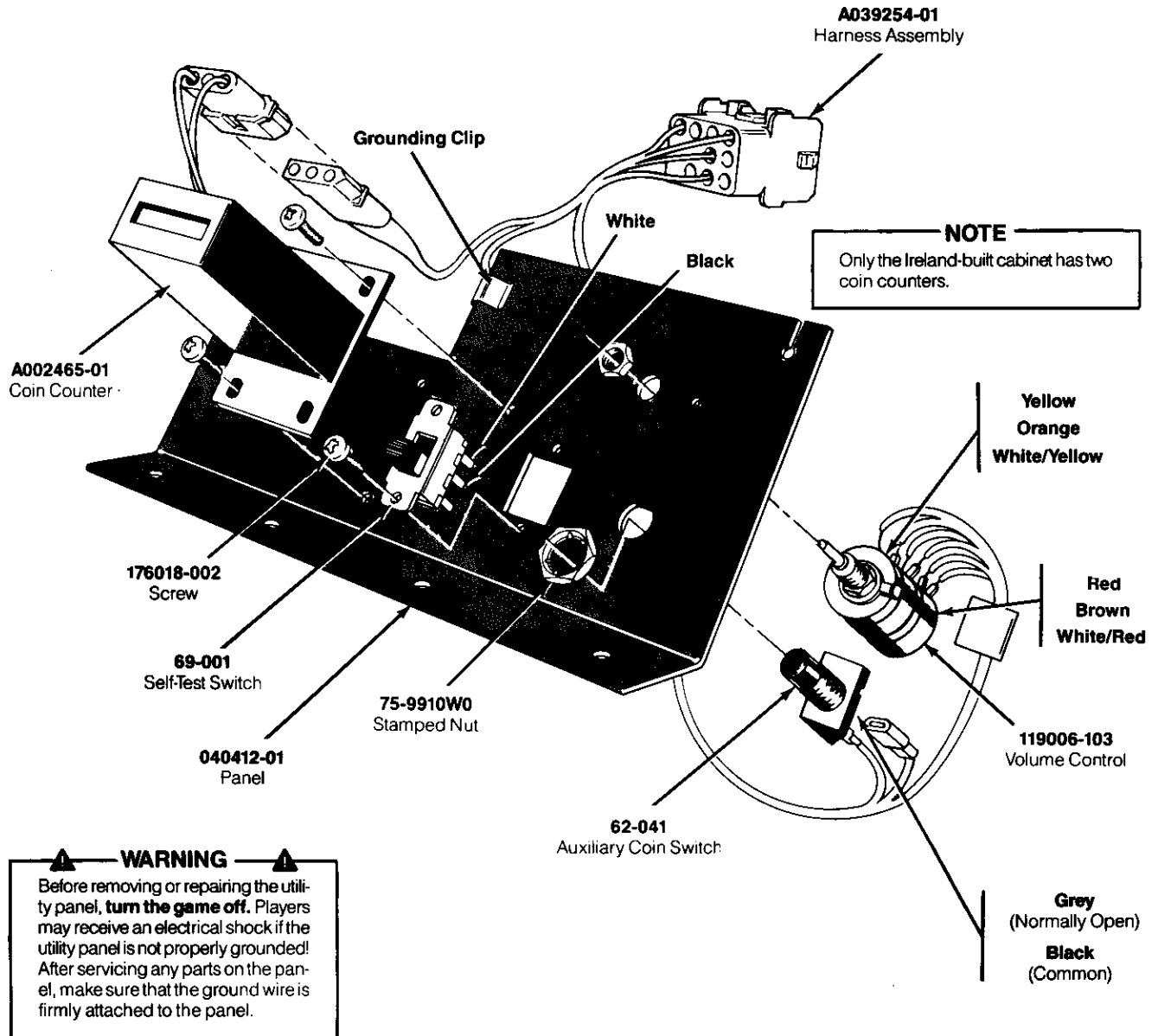

**Figure 5-2 Utility Panel Assembly
A040413-01 B
Parts List**

Part No.	Description
A002465-01	Coin Counter
A039254-01	Volume Control Harness Assembly (includes grounding clip)
62-041	SPDT Pushbutton Auxiliary Coin Switch with Black Cap
69-001	DPDT Self-Test Switch
040412-01	Component Panel
75-9910W0	1/8-32 Stamped Nut
119006-103	Dual Volume Control
176018-002	#6-32 x 1/2-Inch Thread-Forming Machine Screw

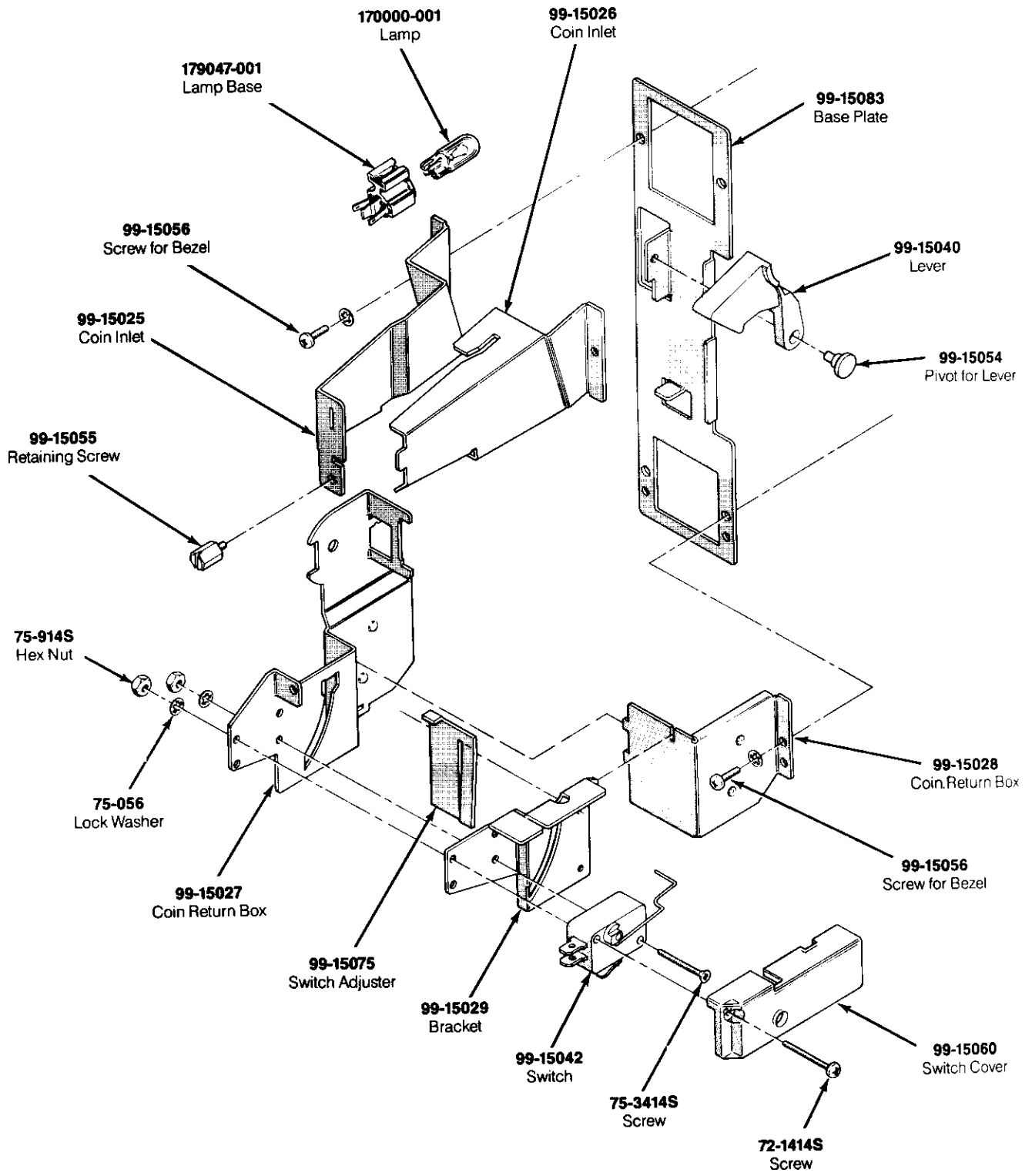

Figure 5-3 Coin Controls, Inc. Coin Door Assembly
171034-xxx A

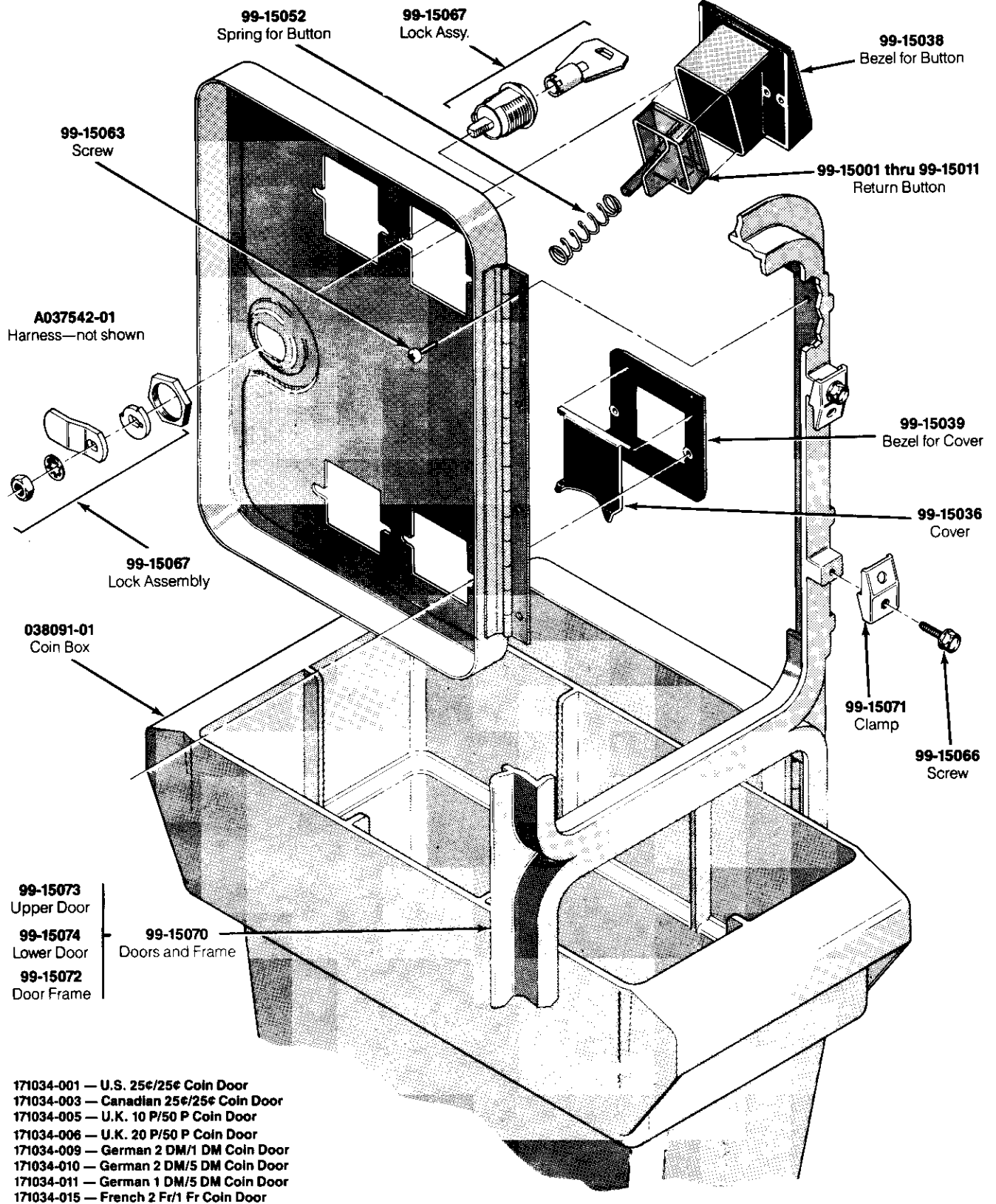

Figure 5-3 Coin Controls, Inc. Coin Door Assembly, continued
 171034-xxx A

Coin Controls, Inc. Coin Door Assembly Parts List

Part No.	Description
A036597-01	Harness Assembly (Ireland-built cabinet only)
A037542-01	Harness Assembly
72-1414S	#4-40 × 7/8-Inch Cross-Recessed Pan-Head Steel Machine Screw
75-056	#6 Internal-Tooth Zinc-Plated Steel Lock Washer
75-914S	#4-40 Steel Machine Hex Nut
75-3414S	#4-40 × 7/8-Inch 82° Cross-Recessed Flat-Head Steel Machine Screw
99-15001	Coin Return Button with U.S. 25-Cent Price Plate
99-15002	Coin Return Button with U.S. \$1 Price Plate
99-15003	Coin Return Button with German 1 DM Price Plate
99-15004	Coin Return Button with German 2 DM Price Plate
99-15005	Coin Return Button with German 5 DM Price Plate
99-15006	Coin Return Button with Belgian 5 Fr Price Plate
99-15007	Coin Return Button with French 1 Fr Price Plate
99-15008	Coin Return Button with Japanese 100 Yen Price Plate
99-15009	Coin Return Button with British 10 Pence Price Plate
99-15010	Coin Return Button with Australian 20-Cent Price Plate
99-15011	Coin Return Button with Italian 100 Lire Price Plate
99-15025	Left Half of Coin Inlet
99-15026	Right Half of Coin Inlet
99-15027	Side Plate of Coin Return Box
99-15028	Base Plate of Coin Return Box
99-15029	Switch Bracket
99-15036	Metal Coin Return Cover
99-15038	Bezel for Coin Return Button
99-15039	Metal Bezel for Coin Return Button
99-15042	Coin Switch for U.S. 25 Cents
99-15052	Spring for Coin Return Button
99-15055	Retaining Screw
99-15056	#4-40 × 7/8-Inch Cross-Recessed Pan-Head Steel Machine Screw
99-15060	Switch Cover
99-15063	Screw for Hinge
99-15066	Screw for Clamp
99-15067	Lock Assembly
99-15070	Doors and Frame
99-15071	Clamp for Frame
99-15072	Door Frame
99-15073	Upper Door
99-15074	Lower Door
99-15075	Switch Adjuster
99-15083	Base Plate—includes:
99-15040	Lever
99-15054	Pivot for Lever
038091-01	Coin Box—not included in assembly (Acceptable substitute is part no. A037491-01)
170000-001	6.3 V Miniature Wedge-Base Incandescent Lamp
171006-035	Metal Coin Mechanism
171050-001	Dual Entry Face Plate
179047-001	Lamp Base

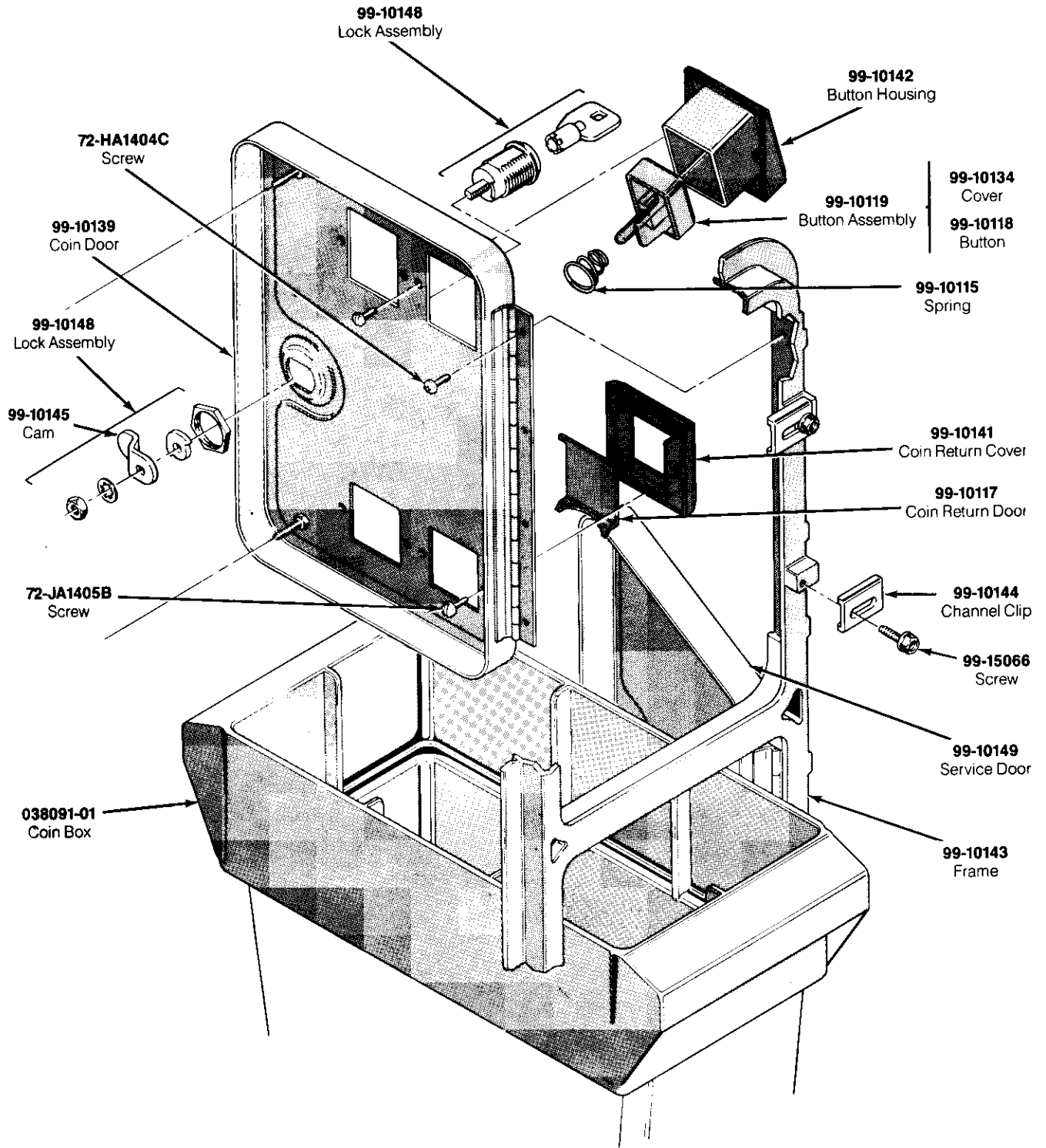
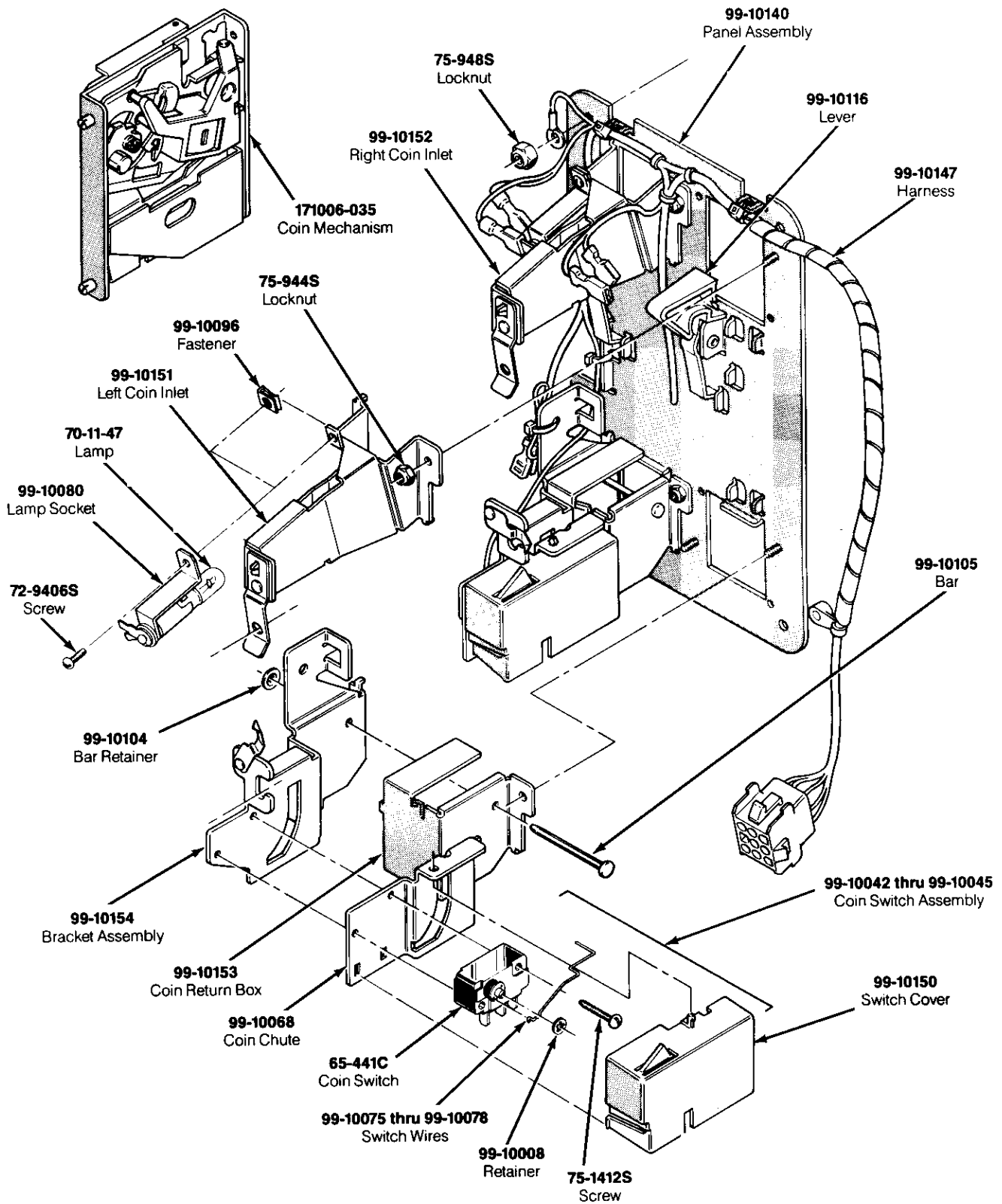

Figure 5-4 Coin Acceptors, Inc. Assembly, continued
171027-001 A



**Figure 5-4 Coin Acceptors, Inc. Assembly
171027-001 A**

Coin Acceptors, Inc. Assembly Parts List

Part No.	Description
171006-035	Metal Coin Mechanism for U.S. \$.25
65-441C	Coin Switch
70-11-47	Miniature Bayonet Lamp
72-9406S	#4-40 x 3/8-Inch Truss-Head Screw
72-HA1404C	#4-40 x 1/4-Inch Pan-Head Screw
72-JA1405B	#4-40 x .31-Inch Pan-Head Screw
75-1412S	#4-40 x 3/4-Inch Pan-Head Screw
75-994S	#4-40 Lock Nut
99-10008	Retainer
99-10042	Coin Switch Assembly for Belgian 5 Fr and U.S. \$.25
99-10043	Coin Switch Assembly for German 1 DM, Japanese 100 Yen, Swiss 1 Fr
99-10044	Coin Switch Assembly for German 2 DM, Italian 100 L, U.S. \$1.00
99-10045	Coin Switch Assembly for Australian \$.20, German 5 DM, British 10 P
99-10068	Coin Return Chute
99-10075	Switch Wire (included in coin switch assembly 99-10043)
99-10076	Switch Wire (included in coin switch assembly 99-10042)
99-10077	Switch Wire (included in coin switch assembly 99-10044)
99-10078	Switch Wire (included in coin switch assembly 99-10045)
99-10080	Lamp Socket
99-10081	Key Holder
99-10096	Fastener
99-10104	Bar Retainer
99-10105	Bar
99-10115	Spring
99-10116	Plastic Coin Return Lever
99-10117	Steel Coin Return Door
99-10118	Amber Coin Return Button
99-10119	Amber Coin Button for U.S. \$.25
99-10134	Coin Button Cover
99-10139	Coin Door
99-10140	Coin Door Inner-Panel Assembly
99-10141	Die-Cast Coin Return Cover
99-10142	Die-Cast Button Housing
99-10143	Coin Door Frame
99-10148	Lock Assembly
99-10149	Service Door
99-10150	Switch Cover
99-10151	Left Coin Inlet
99-10152	Right Coin Inlet
99-10153	Coin Return Box
99-10154	Bracket Assembly
99-15066	Screw for Clamp

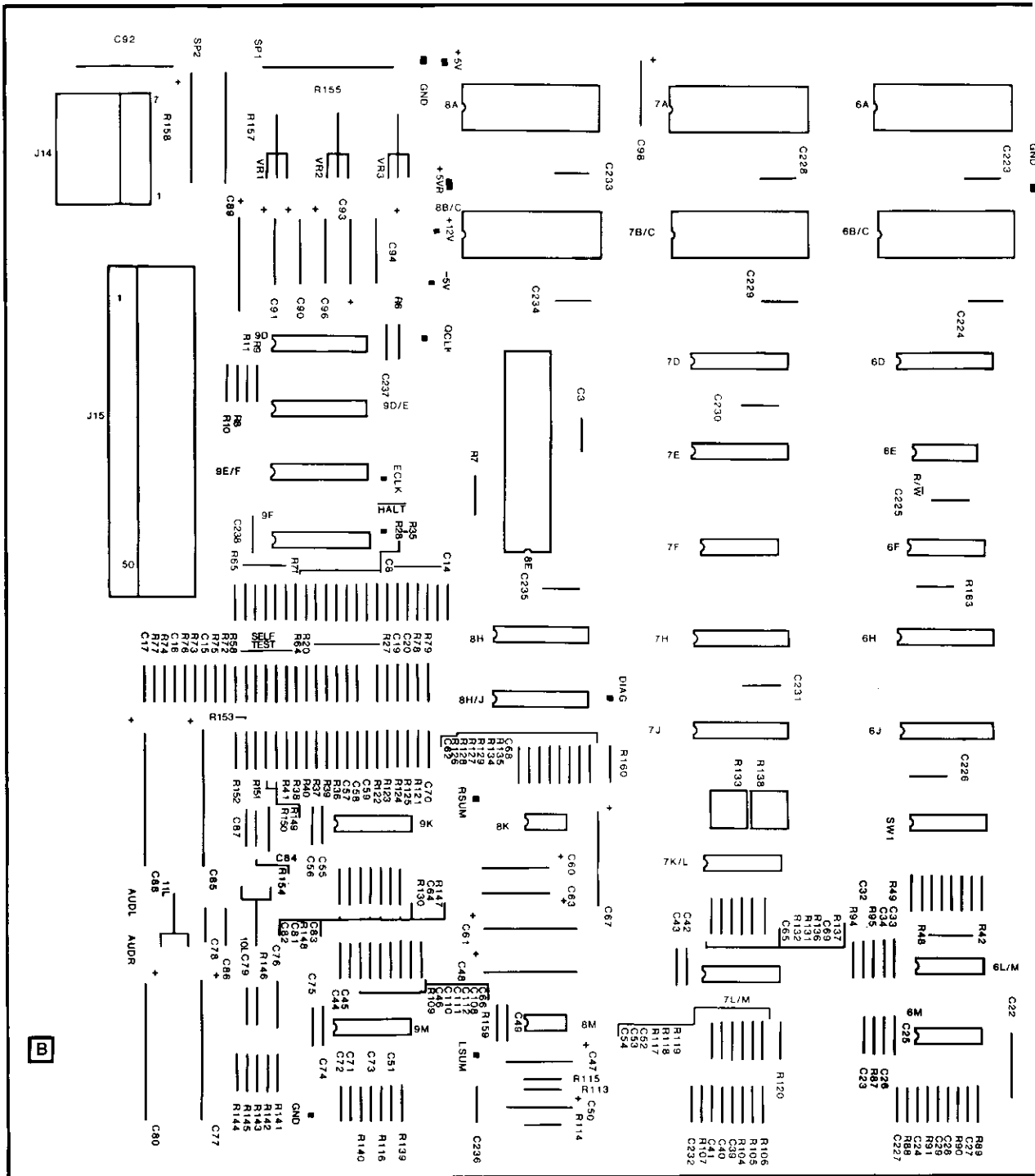
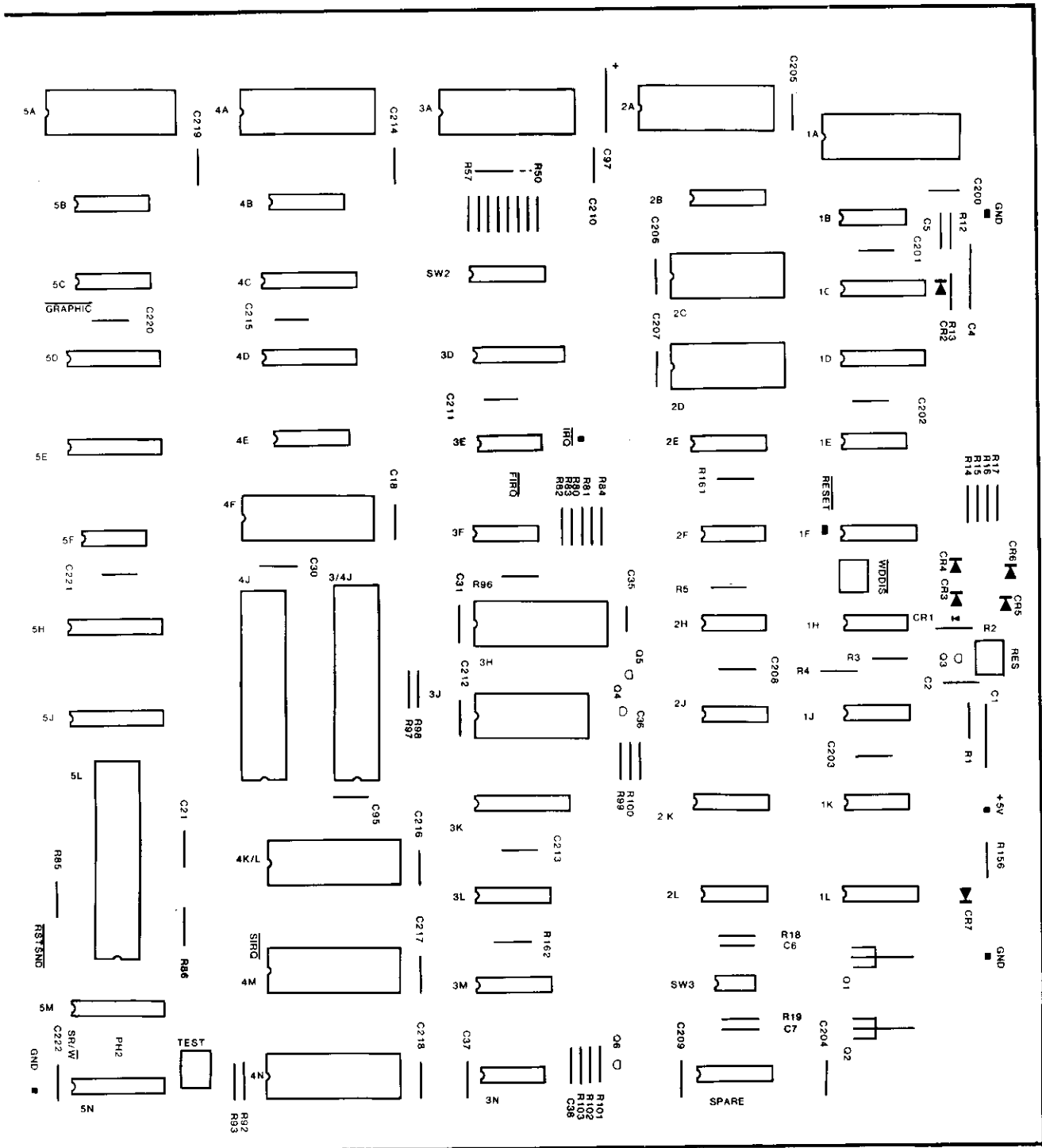

Figure 5-5 FIREFOX Main PCB Assembly
A041403-21 C



NOTICE TO ALL PERSONS RECEIVING THIS DRAWING
 CONFIDENTIAL: Reproduction forbidden without the specific written permission of Atari, Inc., Sunnyvale, CA. This drawing is only conditionally issued, and neither receipt nor possession thereof confers or transfers any right in, or license to use, the subject matter of the drawing or any design or technical information shown thereon, nor any right to reproduce this drawing or any part thereof. Except for manufacture by vendors of Atari, Inc., and for manufacture under the corporation's written license, no right is granted to reproduce this drawing or the subject matter thereof, unless by written agreement with or written permission from the corporation.

Figure 5-5 FIREFOX Main PCB Assembly, continued
A041403-21 C

FIREFOX Main PCB Assembly Parts List

Designator	Description	Part No.
Capacitors		
C1	10 μ F, 35 V, Aluminum Electrolytic Axial-Lead Capacitor	24-350106
C2, C3	0.1 μ F, +80% -20%, 50 V Ceramic Capacitor	122002-104
C4	4.7 μ F, 50 V, Aluminum Electrolytic Axial-Lead Capacitor	24-500475
C5-C21	0.1 μ F, +80% -20%, 50 V Ceramic Capacitor	122002-104
C22	10 μ F, 35 V, Aluminum Electrolytic Axial-Lead Capacitor	24-350106
C23	0.1 μ F, +80% -20%, 50 V Ceramic Capacitor	122002-104
C24	0.001 μ F, 50 V Ceramic Capacitor	122002-102
C25, C26	0.1 μ F, +80% -20%, 50 V Ceramic Capacitor	122002-104
C27-C29	0.001 μ F, 50 V Ceramic Capacitor	122002-102
C30-C43	0.1 μ F, +80% -20%, 50 V Ceramic Capacitor	122002-104
C44-C46	0.0027 μ F, \pm 10%, 50 V Ceramic Axial-Lead Capacitor	122015-272
C47	0.47 μ F, 50 V Aluminum Electrolytic Axial-Lead Capacitor	124001-474
C48	100 μ F, 35 V, Aluminum Electrolytic Axial-Lead Capacitor	24-350107
C49	0.1 μ F, +80% -20%, 50 V Ceramic Capacitor	122002-104
C50	10 μ F, 35 V, Aluminum Electrolytic Axial-Lead Capacitor	24-350106
C51-C56	0.1 μ F, +80% -20%, 50 V Ceramic Capacitor	122002-104
C57-C59	0.0027 μ F, \pm 10%, 50 V Ceramic Axial-Lead Capacitor	122015-272
C60	0.47 μ F, 50 V Aluminum Electrolytic Axial-Lead Capacitor	124001-474
C61	100 μ F, 35 V, Aluminum Electrolytic Axial-Lead Capacitor	24-350107
C62	0.1 μ F, +80% -20%, 50 V Ceramic Capacitor	122002-104
C63	10 μ F, 35 V, Aluminum Electrolytic Axial-Lead Capacitor	24-350106
C64-C66	0.1 μ F, +80% -20%, 50 V Ceramic Capacitor	122002-104
C67	100 μ F, 35 V, Aluminum Electrolytic Axial-Lead Capacitor	24-350107
C68-C70	0.1 μ F, +80% -20%, 50 V Ceramic Capacitor	122002-104
C71-C73	0.0027 μ F, \pm 10%, 50 V Ceramic Axial-Lead Capacitor	122015-272
C74, C75	0.1 μ F, +80% -20%, 50 V Ceramic Capacitor	122002-104
C76	0.22 μ F, -20%, 25 V Ceramic Axial-Lead Capacitor	122004-224
C77	470 μ F, 25 V, Aluminum Electrolytic Axial-Lead Capacitor	24-250477
C78, C79	0.1 μ F, +80% -20%, 50 V Ceramic Capacitor	122002-104
C80	470 μ F, 25 V, Aluminum Electrolytic Axial-Lead Capacitor	24-250477
C81-C83	0.0027 μ F, \pm 10%, 50 V Ceramic Axial-Lead Capacitor	122015-272
C84	0.22 μ F, -20%, 25 V Ceramic Axial-Lead Capacitor	122004-224
C85	470 μ F, 25 V, Aluminum Electrolytic Axial-Lead Capacitor	24-250477
C86, C87	0.1 μ F, +80% -20%, 50 V Ceramic Capacitor	122002-104
C88	470 μ F, 25 V, Aluminum Electrolytic Axial-Lead Capacitor	24-250477
C89	100 μ F, 35 V, Aluminum Electrolytic Axial-Lead Capacitor	24-350107
C90, C91	10 μ F, 35 V, Aluminum Electrolytic Axial-Lead Capacitor	24-350106
C92	100 μ F, 35 V, Aluminum Electrolytic Axial-Lead Capacitor	24-350107
C93, C94	10 μ F, 35 V, Aluminum Electrolytic Axial-Lead Capacitor	24-350106
C95	0.1 μ F, +80% -20%, 50 V Ceramic Capacitor	122002-104
C96	10 μ F, 35 V, Aluminum Electrolytic Axial-Lead Capacitor	24-350106
C97, C98	4.7 μ F, 50 V, Aluminum Electrolytic Axial-Lead Capacitor	24-500475
C200-C239	0.1 μ F, +80% -20%, 50 V Ceramic Capacitor	122002-104

(continued on next page)

FIREFOX Main PCB Assembly Parts List, continued

Designator	Description	Part No.
Diodes		
CR1, CR2	Type-1N4001, 50 V Rectifier Diode	31-1N4001
CR3-CR7	Type-MV5053, Red, Light-Emitting Diode	38-MV5053
Integrated Circuits		
1A	Programmed EPROM Integrated Circuit	136026-108
1B	▲ Type-74S260 Integrated Circuit	37-74S260
1C	Non-Volatile RAM Integrated Circuit	137288-001
1D	Non-Volatile RAM Integrated Circuit	137288-001
1E	Type-74LS02 Integrated Circuit	37-74LS02
1F	Type-74LS259 Integrated Circuit	37-74LS259
1H	Type-74LS14 Integrated Circuit	37-74LS14
1J	Type-7407 Integrated Circuit	37-7407
1K	Type-74LS393 Integrated Circuit	37-74LS393
1L	Type-74LS393 Integrated Circuit	37-74LS393
2A	Programmed EPROM Integrated Circuit	136026-107
2B	▲ Type-74S139 Integrated Circuit	37-74S139
2C	▲ Static RAM Integrated Circuit	137211-001
2D	▲ Static RAM Integrated Circuit	137211-001
2E	Type-74LS138 Integrated Circuit	137177-001
2F	Type-74LS74 Integrated Circuit	37-74LS74
2H	Type-74LS00 Integrated Circuit	37-74LS00
2J	Type-74LS00 Integrated Circuit	37-74LS00
2K	▲ Type-74S139 Integrated Circuit	37-74S139
2L	Type-74LS02 Integrated Circuit	37-74LS02
3/4J	Custom Integrated Circuit	137324-1221
3A	Programmed EPROM Integrated Circuit	136026-106
3D-7D	Type-74LS244 Integrated Circuit	37-74LS244
3E	Type-74LS74 Integrated Circuit	37-74LS74
3F	Type-74LS04 Integrated Circuit	37-74LS04
3H	Custom Integrated Circuit	137308-001
3J	▲ Static RAM Integrated Circuit	137211-001
3K	Type-74LS245 Integrated Circuit	37-74LS245
3L	Type-74LS138 Integrated Circuit	137177-001
3M	Type-74LS163A Integrated Circuit	37-74LS163A
3N	Type-74C04 Integrated Circuit	137309-001
4A	Programmed EPROM Integrated Circuit	136026-105
4B	Type-74LS138 Integrated Circuit	137177-001
4C	Type-74LS244 Integrated Circuit	37-74LS244
4E	Type-74LS138 Integrated Circuit	137177-001
4F	Analog/Digital Converter Integrated Circuit	137243-001
4J	▲ Type-6532A Integrated Circuit	90-6018
4K/L	Programmed EPROM Integrated Circuit	136026-112
4M	Programmed EPROM Integrated Circuit	136026-113
4N	Programmed EPROM Integrated Circuit	136026-114

(continued on next page)

▲ Indicates static-sensitive device.

FIREFOX Main PCB Assembly Parts List, continued

Designator	Description	Part No.
5A	Programmed EPROM Integrated Circuit	136026-104
5B	Type-74LS138 Integrated Circuit	137177-001
5C	▲ Type-74S00 Integrated Circuit	37-74S00
5E	Type-74LS374 Integrated Circuit	13-74LS374
5F	Type-74LS74 Integrated Circuit	37-74LS74
5H, 6H	Type-74LS374 Integrated Circuit	13-74LS374
5J	Type-74LS374 Integrated Circuit	13-74LS374
5L	▲ Type-6502A Integrated Circuit	90-6013
5M	Type-74LS244 Integrated Circuit	37-74LS244
5N	Type-74LS244 Integrated Circuit	37-74LS244
6A	Programmed EPROM Integrated Circuit	136026-103
6B/C	Programmed EPROM Integrated Circuit	136026-111
6E	Type-74LS04 Integrated Circuit	37-74LS04
6F	Type-74LS138 Integrated Circuit	137177-001
6J, 7J	Type-74LS244 Integrated Circuit	37-74LS244
6L/M	▲ Quad Op-Amp Integrated Circuit	37-347
6M	▲ Quad Op-Amp Integrated Circuit	37-347
7A	Programmed EPROM Integrated Circuit	136026-102
7B/C	Programmed EPROM Integrated Circuit	136026-110
7E	Type-74LS244 Integrated Circuit	37-74LS244
7F	Type-74LS259 Integrated Circuit	37-74LS259
7H, 8H	Type-74LS244 Integrated Circuit	37-74LS244
7L/M	▲ Quad Op-Amp Integrated Circuit	37-347
8A	Programmed EPROM Integrated Circuit	136026-101
8B/C	Programmed EPROM Integrated Circuit	136026-109
8E	Microprocessor Integrated Circuit	137249-120
8H/J	Type-74LS244 Integrated Circuit	37-74LS244
8K	Analog Delay Line Integrated Circuit	137310-001
8M	Analog Delay Line Integrated Circuit	137310-001
9D	Type-74LS244 Integrated Circuit	37-74LS244
9D/E	Type-74LS245 Integrated Circuit	37-74LS245
9E/F	Type-74LS244 Integrated Circuit	37-74LS244
9F	Type-74LS244 Integrated Circuit	37-74LS244
9K	▲ Quad Op-Amp Integrated Circuit	37-347
9M	▲ Quad Op-Amp Integrated Circuit	37-347
10L	Type-2002 Integrated Circuit	137151-002
11L	Type-2002 Integrated Circuit	137151-002
VR1	Type-7812 Integrated Circuit	37-7812
VR2	Type-7805 Integrated Circuit	37-7805
VR3	Type-7905 Integrated Circuit	37-7905

Resistors

R1	1 k Ω , \pm 5%, 1/4 W Resistor	110000-102
R2, R3	470 Ω , \pm 5%, 1/4 W Resistor	110000-471
R4	4.7 k Ω , \pm 5%, 1/4 W Resistor	110000-472
R5	10 k Ω , \pm 5%, 1/4 W Resistor	110000-103

▲ Indicates static-sensitive device.

(continued on next page)

FIREFOX Main PCB Assembly Parts List, continued

Designator	Description	Part No.
R6, R7	1 k Ω , $\pm 5\%$, 1/4 W Resistor	110000-102
R8, R9	220 Ω , $\pm 5\%$, 1/4 W Resistor	110000-221
R10, R11	330 Ω , $\pm 5\%$, 1/4 W Resistor	110000-331
R12	22 k Ω , $\pm 5\%$, 1/4 W Resistor	110000-223
R13	10 k Ω , $\pm 5\%$, 1/4 W Resistor	110000-103
R14-R17	330 Ω , $\pm 5\%$, 1/4 W Resistor	110000-331
R18, R19	1 k Ω , $\pm 5\%$, 1/4 W Resistor	110000-102
R20-R27	220 Ω , $\pm 5\%$, 1/4 W Resistor	110000-221
R28-R35	330 Ω , $\pm 5\%$, 1/4 W Resistor	110000-331
R36-R38	220 Ω , $\pm 5\%$, 1/4 W Resistor	110000-221
R39-R41	330 Ω , $\pm 5\%$, 1/4 W Resistor	110000-331
R42-R57	10 k Ω , $\pm 5\%$, 1/4 W Resistor	110000-103
R58-R64	470 Ω , $\pm 5\%$, 1/4 W Resistor	110000-471
R65-R71	1 k Ω , $\pm 5\%$, 1/4 W Resistor	110000-102
R72-R74	470 Ω , $\pm 5\%$, 1/4 W Resistor	110000-471
R75-R77	1 k Ω , $\pm 5\%$, 1/4 W Resistor	110000-102
R78, R79	100 Ω , $\pm 5\%$, 1/4 W Resistor	110000-101
R80-R84	4.7 k Ω , $\pm 5\%$, 1/4 W Resistor	110000-472
R85, R86	1 k Ω , $\pm 5\%$, 1/4 W Resistor	110000-102
R87	100 k Ω , $\pm 5\%$, 1/4 W Resistor	110000-104
R88-R91	1 k Ω , $\pm 5\%$, 1/4 W Resistor	110000-102
R92, R93	10 k Ω , $\pm 5\%$, 1/4 W Resistor	110000-103
R94	1.8 k Ω , $\pm 5\%$, 1/4 W Resistor	110000-182
R95	100 k Ω , $\pm 5\%$, 1/4 W Resistor	110000-104
R96, R97	10 k Ω , $\pm 5\%$, 1/4 W Resistor	110000-103
R98	3.3 k Ω , $\pm 5\%$, 1/4 W Resistor	110000-332
R99	1 k Ω , $\pm 5\%$, 1/4 W Resistor	110000-102
R100	3.3 k Ω , $\pm 5\%$, 1/4 W Resistor	110000-332
R101	10 k Ω , $\pm 5\%$, 1/4 W Resistor	110000-103
R102	3.3 k Ω , $\pm 5\%$, 1/4 W Resistor	110000-332
R103	1 k Ω , $\pm 5\%$, 1/4 W Resistor	110000-102
R104, R105	47 k Ω , $\pm 5\%$, 1/4 W Resistor	110000-473
R106	6.8 k Ω , $\pm 5\%$, 1/4 W Resistor	110000-682
R107-R109	12 k Ω , $\pm 5\%$, 1/4 W Resistor	110000-123
R110	47 k Ω , $\pm 5\%$, 1/4 W Resistor	110000-473
R111	22 k Ω , $\pm 5\%$, 1/4 W Resistor	110000-223
R112	47 k Ω , $\pm 5\%$, 1/4 W Resistor	110000-473
R113	68 k Ω , $\pm 5\%$, 1/4 W Resistor	110000-683
R114	12 k Ω , $\pm 5\%$, 1/4 W Resistor	110000-123
R115	1.5 k Ω , $\pm 5\%$, 1/4 W Resistor	110000-152
R116	470 k Ω , $\pm 5\%$, 1/4 W Resistor	110000-474
R117, R118	47 k Ω , $\pm 5\%$, 1/4 W Resistor	110000-473
R119	15 k Ω , $\pm 5\%$, 1/4 W Resistor	110000-153
R120-R122	12 k Ω , $\pm 5\%$, 1/4 W Resistor	110000-123
R123	47 k Ω , $\pm 5\%$, 1/4 W Resistor	110000-473
R124	22 k Ω , $\pm 5\%$, 1/4 W Resistor	110000-223

(continued on next page)

FIREFOX Main PCB Assembly Parts List, continued

Designator	Description	Part No.
R125	47 k Ω , $\pm 5\%$, 1/4 W Resistor	110000-473
R126	100 Ω , $\pm 5\%$, 1/4 W Resistor	110000-101
R127	68 k Ω , $\pm 5\%$, 1/4 W Resistor	110000-683
R128	12 k Ω , $\pm 5\%$, 1/4 W Resistor	110000-123
R129	1.5 k Ω , $\pm 5\%$, 1/4 W Resistor	110000-152
R130	470 k Ω , $\pm 5\%$, 1/4 W Resistor	110000-474
R131	100 k Ω , $\pm 5\%$, 1/4 W Resistor	110000-104
R132	4.7 k Ω , $\pm 5\%$, 1/4 W Resistor	110000-472
R133	10 k Ω Horizontal Trimming Potentiometer	119002-103
R134	10 k Ω , $\pm 5\%$, 1/4 W Resistor	110000-103
R135	2.7 k Ω , $\pm 5\%$, 1/4 W Resistor	110000-272
R136	100 k Ω , $\pm 5\%$, 1/4 W Resistor	110000-104
R137	4.7 k Ω , $\pm 5\%$, 1/4 W Resistor	110000-472
R138	10 k Ω Horizontal Trimming Potentiometer	119002-103
R139, R140	12 k Ω , $\pm 5\%$, 1/4 W Resistor	110000-123
R141	10 k Ω , $\pm 5\%$, 1/4 W Resistor	110000-103
R142	22 k Ω , $\pm 5\%$, 1/4 W Resistor	110000-223
R143	1 k Ω , $\pm 5\%$, 1/4 W Resistor	110000-102
R144	10 Ω , $\pm 5\%$, 1/4 W Resistor	110000-100
R145	220 Ω , $\pm 5\%$, 1/4 W Resistor	110000-221
R146	1 Ω , $\pm 5\%$, 1/4 W Resistor	110000-010
R147, R148	12 k Ω , $\pm 5\%$, 1/4 W Resistor	110000-123
R149	10 k Ω , $\pm 5\%$, 1/4 W Resistor	110000-103
R150	22 k Ω , $\pm 5\%$, 1/4 W Resistor	110000-223
R151	1 k Ω , $\pm 5\%$, 1/4 W Resistor	110000-102
R152	10 Ω , $\pm 5\%$, 1/4 W Resistor	110000-100
R153	220 k Ω , $\pm 5\%$, 1/4 W Resistor	110000-221
R154	1 Ω , $\pm 5\%$, 1/4 W Resistor	110000-010
R155	62 Ω , $\pm 5\%$, 5 W Resistor	116001-620
R156	150 Ω , $\pm 5\%$, 1/4 W Resistor	110000-151
R157, R158	220 Ω , $\pm 5\%$, 3 W Resistor	110022-221
R159	100 Ω , $\pm 5\%$, 1/4 W Resistor	110000-101
R160	10 k Ω , $\pm 5\%$, 1/4 W Resistor	110000-103
R161-R164	1 k Ω , $\pm 5\%$, 1/4 W Resistor	110000-102
R165	330 Ω , $\pm 5\%$, 1/4 W Resistor	110000-331

Sockets

1A-8A	28-Contact, Medium-Insertion-Force IC Socket	79-42C28
1C	18-Contact, Medium-Insertion-Force IC Socket	79-42C18
1D	18-Contact, Medium-Insertion-Force IC Socket	79-42C18
2C	24-Contact, Medium-Insertion-Force IC Socket	79-42C24
2D	24-Contact, Medium-Insertion-Force IC Socket	79-42C24
34J	40-Contact, Medium-Insertion-Force IC Socket	79-42C40
3H	28-Contact, Medium-Insertion-Force IC Socket	79-42C28
3J	24-Contact, Medium-Insertion-Force IC Socket	79-42C24

(continued on next page)

FIREFOX Main PCB Assembly Parts List, continued

Designator	Description	Part No.
4F	28-Contact, Medium-Insertion-Force IC Socket	79-42C28
4J	40-Contact, Medium-Insertion-Force IC Socket	79-42C40
4K/L	28-Contact, Medium-Insertion-Force IC Socket	79-42C28
4M	28-Contact, Medium-Insertion-Force IC Socket	79-42C28
4N	28-Contact, Medium-Insertion-Force IC Socket	79-42C28
5L	40-Contact, Medium-Insertion-Force IC Socket	79-42C40
6B/C	28-Contact, Medium-Insertion-Force IC Socket	79-42C28
7B/C	28-Contact, Medium-Insertion-Force IC Socket	79-42C28
8B/C	28-Contact, Medium-Insertion-Force IC Socket	79-42C28
8E	40-Contact, Medium-Insertion-Force IC Socket	79-42C40
Transistors		
Q1, Q2	Type-2N6044 Transistor	34-2N6044
Q3	Type-2N3904 Transistor	34-2N3904
Q4	Type-2N3906 Transistor	34-2N3906
Q5	Type-2N3904 Transistor	34-2N3904
Q6	Type-2N3906 Transistor	34-2N3906
Miscellaneous		
SW1, SW2	8-Toggle DIP Switch (Acceptable substitute is part no. 66-118P1T)	160031-008
SW3	4-Toggle DIP Switch	66-114P1T
	7-Circuit Header Connector	179165-007
	Nylon Snap-In Fastener	81-4302
	Test Point (Acceptable substitute is part no. 020670-001)	179051-002
	50-Circuit, 4-Wall Header, Right-Angle Connector	179186-001

Note: See Cabinet-Mounted Assemblies Parts List for part number of 50-circuit ribbon cable assembly.

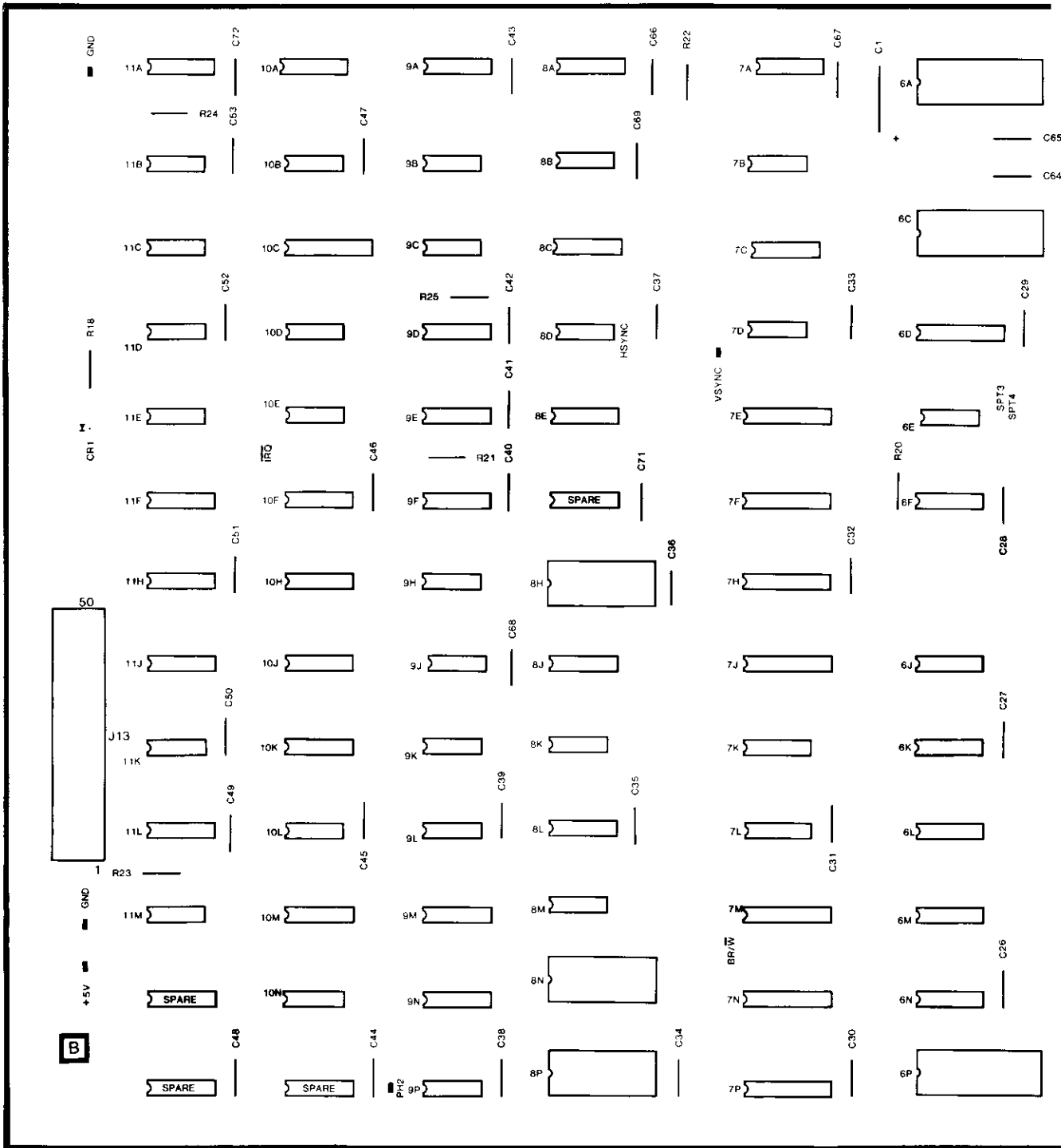
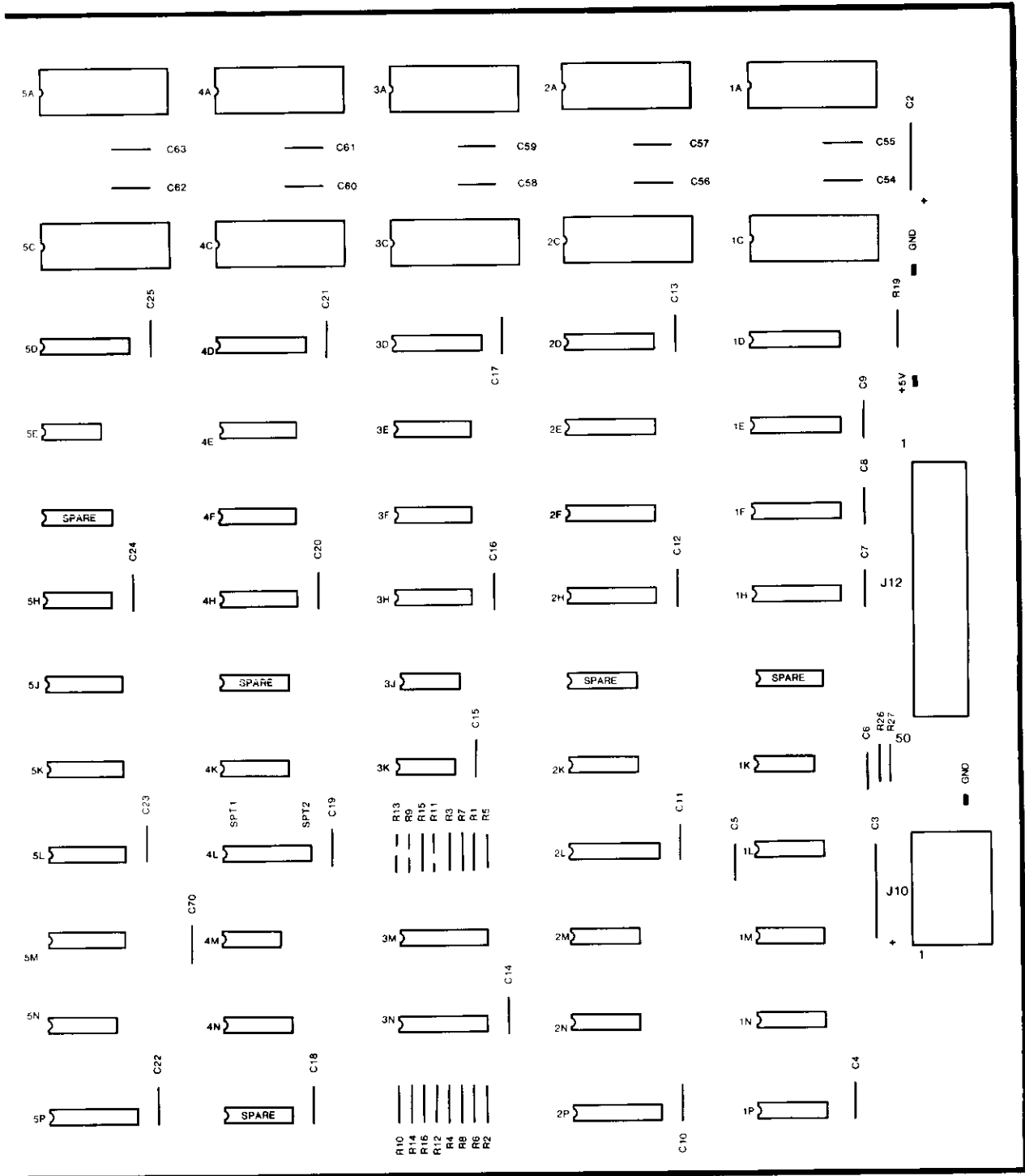

Figure 5-6 FIREFOX Graphics PCB Assembly
A041324-01 C



NOTICE TO ALL PERSONS RECEIVING THIS DRAWING
 CONFIDENTIAL: Reproduction forbidden without the specific written permission of Atari, Inc., Sunnyvale, CA. This drawing is only conditionally issued, and neither receipt nor possession thereof confers or transfers any right in, or license to use, the subject matter of the drawing or any design or technical information shown thereon, nor any right to reproduce this drawing or any part thereof. Except for manufacture by vendors of Atari, Inc., and for manufacture under the corporation's written license, no right is granted to reproduce this drawing or the subject matter thereof, unless by written agreement with or written permission from the corporation.

Figure 5-6 FIREFOX Graphics PCB Assembly, continued
A041324-01 C

Graphics PCB Assembly Parts List

Designator	Description	Part No.
Capacitors		
C1, C2	4.7 μ F, 35 V, Aluminum Electrolytic Axial-Lead Capacitor	124000-475
C3	100 μ F, 35 V, Aluminum Electrolytic Axial-Lead Capacitor	124001-107
C4-C72	0.1 μ F, +80% -20%, 50 V Ceramic Capacitor	122002-104
Integrated Circuits		
1D-6D	Type-74LS299 Integrated Circuit	137180-001
1E	▲ Type-74S374 Integrated Circuit	137206-001
1F	▲ Type-74S374 Integrated Circuit	137206-001
1H	▲ Type-74S374 Integrated Circuit	137206-001
1K	▲ Type-74S04 Integrated Circuit	37-74S04
1L	Type-74LS153 Integrated Circuit	37-74LS153
1M	Type-74LS153 Integrated Circuit	37-74LS153
1N	Type-74LS153 Integrated Circuit	37-74LS153
1P	Type-74LS153 Integrated Circuit	37-74LS153
2E	Type-74LS245 Integrated Circuit	37-74LS245
2F	Type-74LS245 Integrated Circuit	37-74LS245
2H	Type-74LS245 Integrated Circuit	37-74LS245
2K	▲ Type-74S157 Integrated Circuit	37-74S157
2L	Type-74LS240 Integrated Circuit	137251-001
2M	Type-74LS158 Integrated Circuit	137203-001
2N	Type-74LS158 Integrated Circuit	137203-001
2P	Type-74LS374 Integrated Circuit	37-74LS374
3E	▲ Static RAM Integrated Circuit	137199-001
3F	▲ Static RAM Integrated Circuit	137199-001
3H	▲ Static RAM Integrated Circuit	137199-001
3J	Type-74LS74 Integrated Circuit	37-74LS74
3K	▲ Type-74S260 Integrated Circuit	37-74S260
3M	▲ Type-74S374 Integrated Circuit	137206-001
3N	▲ Type-74S374 Integrated Circuit	137206-001
4E	▲ Static RAM Integrated Circuit	137199-001
4F	▲ Static RAM Integrated Circuit	137199-001
4H	▲ Static RAM Integrated Circuit	137199-001
4K	▲ Type-74S157 Integrated Circuit	37-74S157
4L	Type-74LS240 Integrated Circuit	137251-001
4M	▲ Type-74S08 Integrated Circuit	37-74S08
4N	Type-74LS175 Integrated Circuit	37-74LS175
5E	Type-74LS32 Integrated Circuit	37-74LS32
5H	Type-74S161 Integrated Circuit	137287-001
5J	▲ Static RAM Integrated Circuit	137199-002
5K	▲ Static RAM Integrated Circuit	137199-002
5L	▲ Static RAM Integrated Circuit	137199-002
5M	▲ Static RAM Integrated Circuit	137199-002
5N	Type-74LS157 Integrated Circuit	37-74LS157
5P	▲ Type-74S374 Integrated Circuit	137206-001
6E	▲ Type-74S32 Integrated Circuit	37-74S32
6F	Type-74S175 Integrated Circuit	37-74S175

(continued on next page)

▲ Indicates static-sensitive device.

Graphics PCB Assembly Parts List, continued

Designator	Description	Part No.
6J	Type-74S161 Integrated Circuit	137287-001
6K	Type-74S161 Integrated Circuit	137287-001
6L	Type-74S161 Integrated Circuit	137287-001
6M	Type-74S161 Integrated Circuit	137287-001
6N	Type-74S161 Integrated Circuit	137287-001
7A	Type-74LS163 Integrated Circuit	137274-001
7B	Type-74LS86 Integrated Circuit	37-74LS86
7C	Type-74LS174 Integrated Circuit	37-74LS174
7D	Type-74LS08 Integrated Circuit	37-74LS08
7E	Type-74LS374 Integrated Circuit	37-74LS374
7F	Type-74LS374 Integrated Circuit	37-74LS374
7H	Type-74LS374 Integrated Circuit	37-74LS374
7J	Type-74LS374 Integrated Circuit	37-74LS374
7K	Type-74S283 Integrated Circuit	137204-001
7L	Type-74S283 Integrated Circuit	137204-001
7M	Type-74LS245 Integrated Circuit	37-74LS245
7N	Type-74LS245 Integrated Circuit	37-74LS245
7P	▲ Type-74S374 Integrated Circuit	137206-001
8A	Type-74LS163 Integrated Circuit	137274-001
8B	▲ Type-74S74 Integrated Circuit	37-74S74
8C	Type-74LS109 Integrated Circuit	37-74LS109
8D	Type-7414 Integrated Circuit	37-7414
8E	Type-74LS74 Integrated Circuit	37-74LS74
8J	Type-74LS138 Integrated Circuit	137177-001
8K	Type-74LS20 Integrated Circuit	37-74LS20
8L	Type-74LS157 Integrated Circuit	37-74LS157
8M	Type-74LS32 Integrated Circuit	37-74LS32
9A	Type-74LS163 Integrated Circuit	137274-001
9B	▲ Type-74S04 Integrated Circuit	37-74S04
9C	Type-74LS10 Integrated Circuit	37-74LS10
9D	Type-74LS163A Integrated Circuit	37-74LS163A
9E	Type-74S163 Integrated Circuit	137274-001
9F	Type-74LS163A Integrated Circuit	37-74LS163A
9H	Type-74LS86 Integrated Circuit	37-74LS86
9J	Type-74LS00 Integrated Circuit	37-74LS00
9K	Type-74LS08 Integrated Circuit	37-74LS08
9L	Type-74LS10 Integrated Circuit	37-74LS10
9M	Type-74LS157 Integrated Circuit	37-74LS157
9N	Type-74LS109 Integrated Circuit	37-74LS109
9P	▲ Type-74S74 Integrated Circuit	37-74S74
10A	Type-74LS163 Integrated Circuit	137274-001
10B	Type-74LS11 Integrated Circuit	137149-001
10C	Type-74LS273 Integrated Circuit	37-74LS273
10D	▲ Type-74S02 Integrated Circuit	37-74S02
10E	▲ Type-74S00 Integrated Circuit	37-74S00
10F	Type-74S161 Integrated Circuit	137287-001

(continued on next page)

▲ Indicates static-sensitive device.

Graphics PCB Assembly Parts List, continued

Designator	Description	Part No.
10H	Type-74S139 Integrated Circuit	37-74S139
10J	Type-74LS157 Integrated Circuit	37-74LS157
10K	Type-74LS157 Integrated Circuit	37-74LS157
10L	Type-74LS32 Integrated Circuit	37-74LS32
10M	Type-74LS157 Integrated Circuit	37-74LS157
10N	Type-74LS04 Integrated Circuit	37-74LS04
11A	Type-74LS163 Integrated Circuit	137274-001
11B	Type-74LS74 Integrated Circuit	37-74LS74
11C	Type-74LS00 Integrated Circuit	37-74LS00
11D	▲ Type-74S08 Integrated Circuit	37-74S08
11E	Type-74LS74 Integrated Circuit	37-74LS74
11F	Type-74LS157 Integrated Circuit	37-74LS157
11H	Type-74S161 Integrated Circuit	137287-001
11J	Type-74LS157 Integrated Circuit	37-74LS157
11K	▲ Type-74S04 Integrated Circuit	37-74S04
11L	Type-74S161 Integrated Circuit	137287-001
11M	Type-74LS74 Integrated Circuit	37-74LS74
Resistors		
R1-R16	1 k Ω , \pm 5%, 1/4 W Resistor	110000-102
R18	150 k Ω , \pm 5%, 1/4 W Resistor	110000-151
R19-R25	1 k Ω , \pm 5%, 1/4 W Resistor	110000-102
R27	150 k Ω , \pm 5%, 1/4 W Resistor	110000-151
R28, R29	10 k Ω , \pm 5%, 1/4 W Resistor	110000-103
Sockets		
1A	28-Contact, Medium-Insertion-Force IC Socket	79-42C28
1C	28-Contact, Medium-Insertion-Force IC Socket	79-42C28
2A	28-Contact, Medium-Insertion-Force IC Socket	79-42C28
2C	28-Contact, Medium-Insertion-Force IC Socket	79-42C28
3A	28-Contact, Medium-Insertion-Force IC Socket	79-42C28
3C	28-Contact, Medium-Insertion-Force IC Socket	79-42C28
4A	28-Contact, Medium-Insertion-Force IC Socket	79-42C28
4C	28-Contact, Medium-Insertion-Force IC Socket	79-42C28
5A	28-Contact, Medium-Insertion-Force IC Socket	79-42C28
5C	28-Contact, Medium-Insertion-Force IC Socket	79-42C28
6A	28-Contact, Medium-Insertion-Force IC Socket	79-42C28
6C	28-Contact, Medium-Insertion-Force IC Socket	79-42C28
6P	28-Contact, Medium-Insertion-Force IC Socket	79-42C28
8H	24-Contact, Medium-Insertion-Force IC Socket	79-42C24
8N	24-Contact, Medium-Insertion-Force IC Socket	79-42C24
8P	24-Contact, Medium-Insertion-Force IC Socket	79-42C24
Miscellaneous		
CR1	Type-MV5053, Red Light-Emitting Diode	38-MV5053
J10	2-Circuit, Right-Angle Connector Header	179165-002
J10	4-Circuit, Right-Angle Connector Header	179165-004
J12, J13	50-Pin, Right-Angle Ribbon	179186-001
	Test Point (Acceptable substitute is part no. 020670-001)	179051-002

▲ Indicates static-sensitive device.

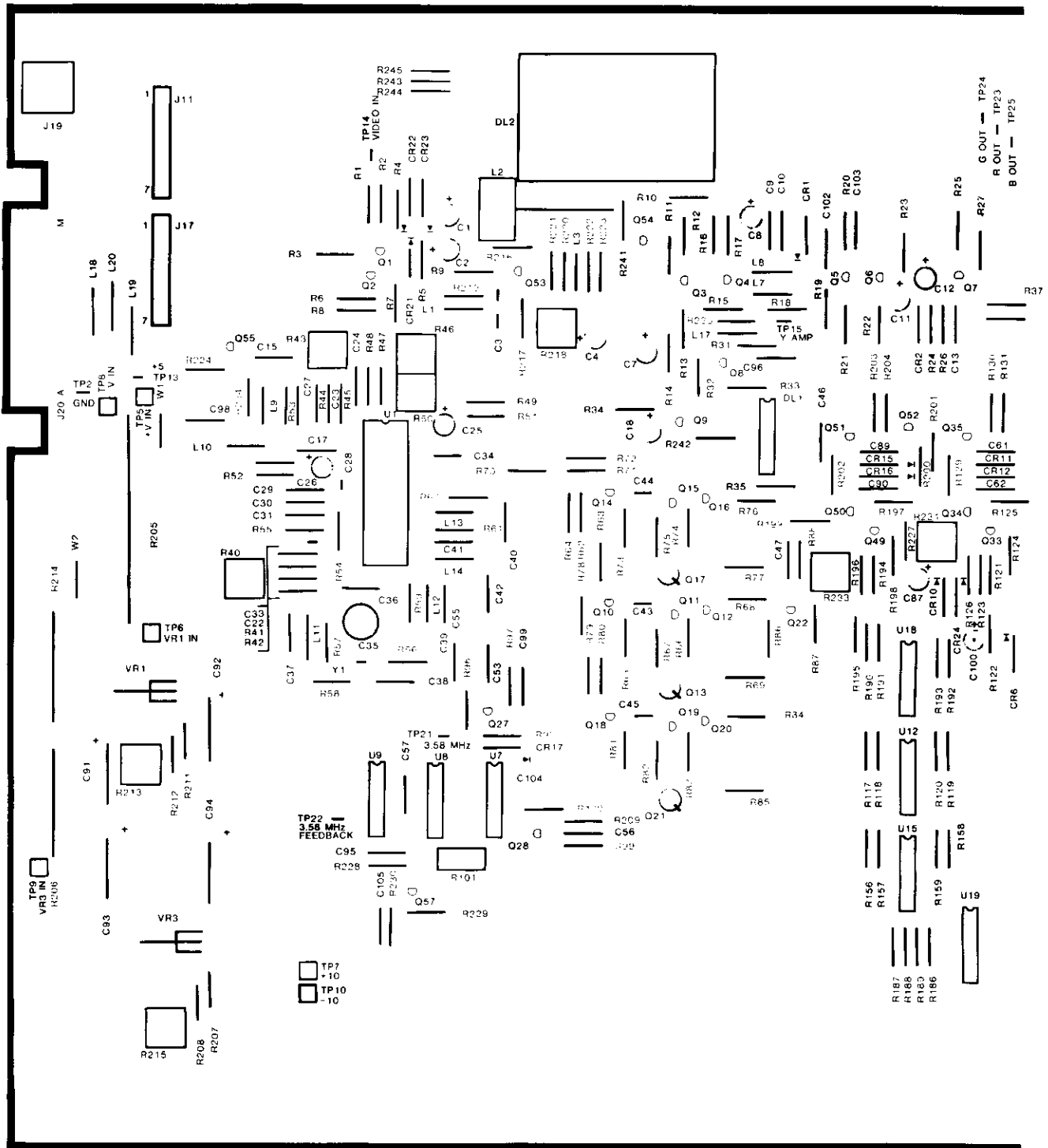

*National Television Service Committee

**Figure 5-7 FIREFOX NTSC* Demodulator PCB Assembly
A041343-01 B**

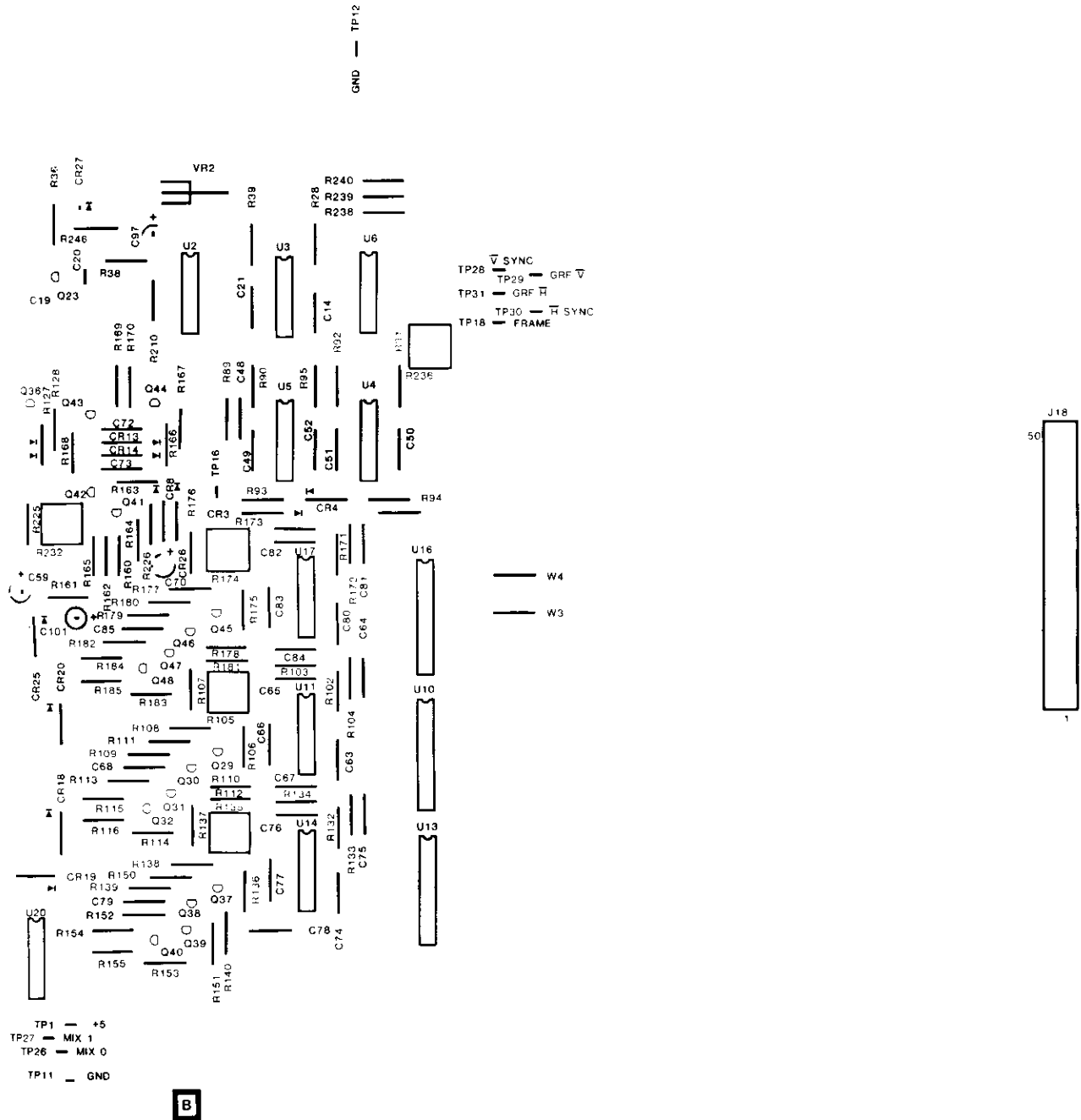

NOTICE TO ALL PERSONS RECEIVING THIS DRAWING

CONFIDENTIAL: Reproduction forbidden without the specific written permission of Atari, Inc., Sunnyvale, CA. This drawing is only conditionally issued, and neither receipt nor possession thereof confers or transfers any right in, or license to use, the subject matter of the drawing or any design or technical information shown thereon, nor any right to reproduce this drawing or any part thereof. Except for manufacture by vendors of Atari, Inc., and for manufacture under the corporation's written license, no right is granted to reproduce this drawing or the subject matter thereof, unless by written agreement with or written permission from the corporation.

Figure 5-7 FIREFOX NTSC Demodulator PCB Assembly, continued
A041343-01 B

NTSC Demodulator PCB Assembly Parts List

Designator	Description	Part No.
Capacitors		
C1	100 μ F, 10 V, Aluminum Electrolytic Radial-Lead Capacitor	123013-107
C2	470 μ F, 10 V, Aluminum Electrolytic Radial-Lead Capacitor	24-100477
C3	1000 pF, \pm 5%, 100 V, NPO Axial-Lead Ceramic Capacitor	122016-102
C4	1.0 μ F, 50 V, Aluminum Electrolytic Radial-Lead Capacitor	123001-105
C7, C8	100 μ F, 10 V, Aluminum Electrolytic Radial-Lead Capacitor	123013-107
C9	270 pF, \pm 10%, 100 V, NPO Axial-Lead Ceramic Capacitor	122016-271
C10	330 pF, \pm 5%, 100 V, NPO Axial-Lead Ceramic Capacitor	122016-331
C11, C12	0.22 μ F, 100 V Polyester Radial-Lead Capacitor	21-101224
C13	3300 pF, \pm 10%, 100 V, NPO Axial-Lead Ceramic Capacitor	122016-332
C14	1000 pF, \pm 5%, 100 V, NPO Axial-Lead Ceramic Capacitor	122016-102
C15	51 pF, \pm 10%, 100 V, NPO Axial-Lead Ceramic Capacitor	122016-510
C17	220 pF, \pm 5%, 100 V, NPO Axial-Lead Ceramic Capacitor	122016-221
C18	10 μ F, 50 V, Aluminum Electrolytic Radial-Lead Capacitor	123001-106
C19	100 pF, \pm 5%, 100 V, NPO Axial-Lead Ceramic Capacitor	122016-101
C20	0.022 μ F, 100 V, Polyester Radial-Lead Capacitor	21-101223
C21	470 pF, 100 V, NPO Axial-Lead Ceramic Capacitor	122016-471
C22-C24	0.01 μ F, +80% -20%, 25 V Minimum, Axial-Lead Ceramic Capacitor	122005-103
C25, C26	1.0 μ F, 50 V, Aluminum Electrolytic Radial-Lead Capacitor	123001-105
C27	270 pF, \pm 10%, 100 V, NPO Axial-Lead Ceramic Capacitor	122016-271
C28	1.0 μ F, \pm 10%, 50 V Minimum, Radial-Lead Ceramic Capacitor	121015-105
C29-C31	0.01 μ F, +80% -20%, 25 V Minimum, Axial-Lead Ceramic Capacitor	122005-103
C32	1.0 μ F, \pm 10%, 50 V Minimum, Radial-Lead Ceramic Capacitor	121015-105
C33	0.01 μ F, +80% -20%, 25 V Minimum, Axial-Lead Ceramic Capacitor	122005-103
C34	0.47 μ F, 100 V, Polyester Radial-Lead Capacitor	21-101474
C35	5.5-40 pF, PC Mount, Variable Ceramic Disc Capacitor	121026-001
C37	100 pF, \pm 5%, 100 V, NPO Axial-Lead Ceramic Capacitor	122016-101
C38	150 pF, \pm 5%, 100 V, NPO Axial-Lead Ceramic Capacitor	122016-151
C39	75 pF, \pm 10%, 100 V, NPO Axial-Lead Ceramic Capacitor	122016-750
C40	120 pF, \pm 10%, 100 V, NPO Axial-Lead Ceramic Capacitor	122016-121
C41	330 pF, \pm 5%, 100 V, NPO Axial-Lead Ceramic Capacitor	122016-331
C42	1000 pF, \pm 5%, 100 V, NPO Axial-Lead Ceramic Capacitor	122016-102
C43-C45	0.1 μ F, 100 V Polyester Radial-Lead Capacitor	21-101104
C46	0.01 μ F, +80% -20%, 25 V Minimum, Axial-Lead Ceramic Capacitor	122005-103
C47, C48	220 pF, \pm 5%, 100 V, NPO Axial-Lead Ceramic Capacitor	122016-221
C49	470 pF, 100 V, NPO Axial-Lead Ceramic Capacitor	122016-471
C50	220 pF, \pm 5%, 100 V, NPO Axial-Lead Ceramic Capacitor	122016-221
C51	1000 pF, \pm 5%, 100 V, NPO Axial-Lead Ceramic Capacitor	122016-102
C52	180 pF, \pm 10%, 100 V, NPO Axial-Lead Ceramic Capacitor	122016-181
C53	220 pF, \pm 5%, 100 V, NPO Axial-Lead Ceramic Capacitor	122016-221
C56	0.05 μ F, +80% -20%, 25 V Ceramic Capacitor	121002-503
C57	10 pF, \pm 5%, 100 V, NPO Axial-Lead Ceramic Capacitor	122016-100
C59	100 μ F, 10 V, Aluminum Electrolytic Radial-Lead Capacitor	123013-107
C61, C62	0.01 μ F, +80% -20%, 25 V Minimum, Axial-Lead Ceramic Capacitor	122005-103
C63, C64	0.1 μ F, \pm 10%, 25 V Ceramic Capacitor	122006-104

(continued on next page)

NTSC Demodulator PCB Assembly Parts List, continued

Designator	Description	Part No.
C65	0.01 μ F, +80% -20%, 25 V Minimum, Axial-Lead Ceramic Capacitor	122005-103
C66	0.1 μ F, \pm 10%, 25 V Ceramic Capacitor	122006-104
C67	0.01 μ F, +80% -20%, 25 V Minimum, Axial-Lead Ceramic Capacitor	122005-103
C68	15 pF, \pm 5%, 100 V, NPO Axial-Lead Ceramic Capacitor	122016-150
C70	100 μ F, 10 V, Aluminum Electrolytic Radial-Lead Capacitor	123013-107
C72, C73	0.01 μ F, +80% -20%, 25 V Minimum, Axial-Lead Ceramic Capacitor	122005-103
C74, C75	0.1 μ F, \pm 10%, 25 V Ceramic Capacitor	122006-104
C76	0.01 μ F, +80% -20%, 25 V Minimum, Axial-Lead Ceramic Capacitor	122005-103
C77	0.1 μ F, \pm 10%, 25 V Ceramic Capacitor	122006-104
C78	0.01 μ F, +80% -20%, 25 V Minimum, Axial-Lead Ceramic Capacitor	122005-103
C79	15 pF, \pm 5%, 100 V, NPO Axial-Lead Ceramic Capacitor	122016-150
C80, C81	0.1 μ F, \pm 10%, 25 V Ceramic Capacitor	122006-104
C82	0.01 μ F, +80% -20%, 25 V Minimum, Axial-Lead Ceramic Capacitor	122005-103
C83	0.1 μ F, \pm 10%, 25 V Ceramic Capacitor	122006-104
C84	0.01 μ F, +80% -20%, 25 V Minimum, Axial-Lead Ceramic Capacitor	122005-103
C85	15 pF, \pm 5%, 100 V, NPO Axial-Lead Ceramic Capacitor	122016-150
C87	100 μ F, 10 V, Aluminum Electrolytic Radial-Lead Capacitor	123013-107
C89	0.01 μ F, +80% -20%, 25 V Minimum, Axial-Lead Ceramic Capacitor	122005-103
C90	0.01 μ F, +80% -20%, 25 V Minimum, Axial-Lead Ceramic Capacitor	122005-103
C91-C94	10 μ F, 35 V, Aluminum Electrolytic Radial-Lead Capacitor	24-350106
C95	220 pF, 100 V, NPO Axial-Lead Ceramic Capacitor	122016-221
C96	47 pF, \pm 5%, 100 V, NPO Axial-Lead Ceramic Capacitor	122016-470
C97	100 μ F, 10 V, Aluminum Electrolytic Radial-Lead Capacitor	123013-107
C99	0.01 μ F, +80% -20%, 25 V Minimum, Axial-Lead Ceramic Capacitor	122005-103
C100, C101	10 μ F, 50 V, Aluminum Electrolytic Radial-Lead Capacitor	123001-106
C102	10 pF, \pm 5%, 100 V, NPO Axial-Lead Ceramic Capacitor	122016-100
C103, C104	0.1 μ F, 25 V, NPO Axial-Lead Ceramic Capacitor	122006-104
C105	220 pF, 100 V, NPO Axial-Lead Ceramic Capacitor	122016-221
Diodes		
CR1	Type-1N752A, 5.6 V Diode	32-1N752A
CR2-CR4	Type-1N914, 10 mA, 100 V Switching Diode	31-1N914
CR6	Type-1N914, 10 mA, 100 V Switching Diode	31-1N914
CR8	Type-1N914, 10 mA, 100 V Switching Diode	31-1N914
CR10-CR22	Type-1N914, 10 mA, 100 V Switching Diode	31-1N914
CR26	Type-1N914, 10 mA, 100 V Switching Diode	31-1N914
CR27	Type-38MV5053 Light-Emitting Diode	38-MV5053
Inductors		
L1	15 μ H Miniature Fixed Axial-Lead Inductor	141016-004
L2	8.5-11.5 μ H Variable Inductor	141017-001
L3	18 μ H Miniature Fixed Axial-Lead Inductor	141016-005
L7	33 μ H Miniature Fixed Axial-Lead Inductor	141016-007
L8	68 μ H Miniature Fixed Axial-Lead Inductor	141016-008
L9	15 μ H Miniature Fixed Axial-Lead Inductor	141016-004

(continued on next page)

NTSC Demodulator PCB Assembly Parts List, continued

Designator	Description	Part No.
L10	5.6 μ H Miniature Fixed Axial-Lead Inductor	141016-001
L11	27 μ H Miniature Fixed Axial-Lead Inductor	141016-006
L12	15 μ H Miniature Fixed Axial-Lead Inductor	141016-004
L13	18 μ H Miniature Fixed Axial-Lead Inductor	141016-005
L14	5.6 μ H Miniature Fixed Axial-Lead Inductor	141016-001
L17	5.6 μ H Miniature Fixed Axial-Lead Inductor	141016-001
L18-L20	1.0 μ H Peaking Coil Inductor	141007-001

Integrated Circuits

DL1	500 ns Delay Line Integrated Circuit	137359-001
DL2	NTSC Delay Line Integrated Circuit	137365-001
U1	▲ TV Chroma/Luminance Processor Integrated Circuit	137353-001
U2	Type-74LS08 Integrated Circuit	37-74LS08
U3-U5	▲ CMOS Dual Monostable Multivibrator Integrated Circuit	137354-001
U6	Type-74LS04 Integrated Circuit	37-74LS04
U7	▲ ECL Phase-Frequency Detector Integrated Circuit	137355-001
U8	▲ ECL Voltage-Controlled Multi-Vibrator Integrated Circuit	137356-001
U9	Type-74LS74 Integrated Circuit	37-74LS74
U11	~ 8-Bit D-A Converter Integrated Circuit	137159-001
U10	Type-74LS273 Octal Flip-Flop Integrated Circuit	37-74LS273
U12	▲ Type-4066 Integrated Circuit	37-4066
U13	Type-74LS273 Octal Flip-Flop Integrated Circuit	37-74LS273
U14	▲ 8-Bit D-A Converter Integrated Circuit	137159-001
U15	▲ Type-4066 Integrated Circuit	37-4066
U16	Type-74LS273 Octal Flip-Flop Integrated Circuit	37-74LS273
U17	▲ 8-Bit D-A Converter Integrated Circuit	137159-001
U18	▲ Type-4066 Integrated Circuit	37-4066
U19	Type-7406 Integrated Circuit	37-7406
U20	Type-7407 Integrated Circuit	37-7407
VR1	TO-220, 15 W, Voltage Regulator Integrated Circuit	137233-001
VR2	Type-7805 Integrated Circuit	37-7805
VR3	TO-220, 15 W, Voltage Regulator Integrated Circuit	137232-001

Resistors

R1	75 Ω , $\pm 5\%$, $\frac{1}{4}$ W Resistor	110000-750
R2	47 Ω , $\pm 5\%$, $\frac{1}{4}$ W Resistor	110000-470
R3	2 k Ω $\pm 5\%$, $\frac{1}{4}$ W Resistor	110000-202
R4	240 Ω , $\pm 5\%$, $\frac{1}{4}$ W Resistor	110000-241
R5	910 Ω , $\pm 5\%$, $\frac{1}{4}$ W Resistor	110000-911
R6, R7	560 Ω , $\pm 5\%$, $\frac{1}{4}$ W Resistor	110000-561
R8	1.2 k Ω $\pm 5\%$, $\frac{1}{4}$ W Resistor	110000-122
R9	1 k Ω , $\pm 5\%$, $\frac{1}{4}$ W Resistor	110000-102
R10	2.7 k Ω $\pm 5\%$, $\frac{1}{4}$ W Resistor	110000-272
R11	47 Ω , $\pm 5\%$, $\frac{1}{4}$ W Resistor	110000-470
R12	2 k Ω $\pm 5\%$, $\frac{1}{4}$ W Resistor	110000-202
R13	270 Ω , $\pm 5\%$, $\frac{1}{4}$ W Resistor	110000-271

▲ Indicates static-sensitive device.

(continued on next page)

NTSC Demodulator PCB Assembly Parts List, continued

Designator	Description	Part No.
R14	2.7 k Ω \pm 5%, 1/4 W Resistor	110000-272
R15	1.8 k Ω \pm 5%, 1/4 W Resistor	110000-182
R16	1.5 k Ω , \pm 5%, 1/4 W Resistor	110000-152
R17	150 Ω , \pm 5%, 1/4 W Resistor	110000-151
R18	510 Ω , \pm 5%, 1/4 W Resistor	110000-511
R19	3.9 k Ω \pm 5%, 1/4 W Resistor	110000-392
R20	1.5 k Ω , \pm 5%, 1/4 W Resistor	110000-152
R21	510 Ω , \pm 5%, 1/4 W Resistor	110000-511
R22	3.3 k Ω \pm 5%, 1/4 W Resistor	110000-332
R23	82 k Ω \pm 5%, 1/4 W Resistor	110000-823
R24	1 k Ω , \pm 5%, 1/4 W Resistor	110000-102
R25	220 k Ω \pm 5%, 1/4 W Resistor	110000-224
R26	1.2 k Ω \pm 5%, 1/4 W Resistor	110000-122
R27	1.8 k Ω \pm 5%, 1/4 W Resistor	110000-182
R28	270 k Ω \pm 5%, 1/4 W Resistor	110000-274
R31	47 Ω , \pm 5%, 1/4 W Resistor	110000-470
R32	5.1 k Ω \pm 5%, 1/4 W Resistor	110000-512
R33	470 Ω , \pm 5%, 1/4 W Resistor	110000-471
R34	2.4 k Ω \pm 5%, 1/4 W Resistor	110000-242
R35	510 Ω , \pm 5%, 1/4 W Resistor	110000-511
R36	3.3 k Ω \pm 5%, 1/4 W Resistor	110000-332
R37	15 k Ω \pm 5%, 1/4 W Resistor	110000-153
R38	100 Ω , \pm 5%, 1/4 W Resistor	110000-101
R39	110 k Ω \pm 5%, 1/4 W Resistor	110000-114
R40	100 k Ω , Horizontal Trimming Potentiometer	119002-104
R41	33 k Ω \pm 5%, 1/4 W Resistor	110000-333
R42	330 k Ω \pm 5%, 1/4 W Resistor	110000-334
R43	100 k Ω , Horizontal Trimming Potentiometer	119002-104
R44	33 k Ω \pm 5%, 1/4 W Resistor	110000-333
R45	330 k Ω \pm 5%, 1/4 W Resistor	110000-334
R46	5 k Ω , Horizontal Trimming Potentiometer	119002-502
R47	8.2 k Ω \pm 5%, 1/4 W Resistor	110000-822
R48	22 k Ω \pm 5%, 1/4 W Resistor	110000-223
R49	15 k Ω \pm 5%, 1/4 W Resistor	110000-153
R50	10 k Ω , Horizontal Trimming Potentiometer	119002-103
R51	12 k Ω \pm 5%, 1/4 W Resistor	110000-123
R52	510 Ω , \pm 5%, 1/4 W Resistor	110000-511
R53	10 k Ω \pm 5%, 1/4 W Resistor	110000-103
R54	220 k Ω \pm 5%, 1/4 W Resistor	110000-224
R55	12 k Ω \pm 5%, 1/4 W Resistor	110000-123
R56	5.1 k Ω \pm 5%, 1/4 W Resistor	110000-512
R57	1 k Ω , \pm 5%, 1/4 W Resistor	110000-102
R58	330 Ω , \pm 5%, 1/4 W Resistor	110000-331
R59	3.3 k Ω \pm 5%, 1/4 W Resistor	110000-332
R60	10 Ω , \pm 5%, 1/4 W Resistor	110000-100
R61	270 Ω , \pm 5%, 1/4 W Resistor	110000-271

(continued on next page)

NTSC Demodulator PCB Assembly Parts List, continued

Designator	Description	Part No.
R62	3 k Ω \pm 5%, 1/4 W Resistor	110000-302
R63	47 Ω , \pm 5%, 1/4 W Resistor	110000-470
R64	2 k Ω \pm 5%, 1/4 W Resistor	110000-202
R65	3.9 k Ω \pm 5%, 1/4 W Resistor	110000-392
R66	39 k Ω \pm 5%, 1/4 W Resistor	110000-393
R67	47 Ω , \pm 5%, 1/4 W Resistor	110000-470
R68	4.7 k Ω \pm 5%, 1/4 W Resistor	110000-472
R69	2.2 k Ω \pm 5%, 1/4 W Resistor	110000-222
R70	3 k Ω \pm 5%, 1/4 W Resistor	110000-302
R71	47 Ω , \pm 5%, 1/4 W Resistor	110000-470
R72	2 k Ω \pm 5%, 1/4 W Resistor	110000-202
R73	3.9 k Ω \pm 5%, 1/4 W Resistor	110000-392
R74	39 k Ω \pm 5%, 1/4 W Resistor	110000-393
R75	47 Ω , \pm 5%, 1/4 W Resistor	110000-470
R76	4.7 k Ω \pm 5%, 1/4 W Resistor	110000-472
R77	2.2 k Ω \pm 5%, 1/4 W Resistor	110000-222
R78	3 k Ω \pm 5%, 1/4 W Resistor	110000-302
R79	2 k Ω \pm 5%, 1/4 W Resistor	110000-202
R80	47 Ω , \pm 5%, 1/4 W Resistor	110000-470
R81	3.9 k Ω \pm 5%, 1/4 W Resistor	110000-392
R82	47 Ω , \pm 5%, 1/4 W Resistor	110000-470
R83	39 k Ω \pm 5%, 1/4 W Resistor	110000-393
R84	4.7 k Ω \pm 5%, 1/4 W Resistor	110000-472
R85, R86	2.2 k Ω \pm 5%, 1/4 W Resistor	110000-222
R87	10 k Ω \pm 5%, 1/4 W Resistor	110000-103
R88	5.1 k Ω \pm 5%, 1/4 W Resistor	110000-512
R89	10 k Ω \pm 5%, 1/4 W Resistor	110000-103
R90	110 k Ω \pm 5%, 1/4 W Resistor	110000-114
R91	10 k Ω \pm 5%, 1/4 W Resistor	110000-103
R92	270 k Ω \pm 5%, 1/4 W Resistor	110000-274
R93	330 Ω , \pm 5%, 1/4 W Resistor	110000-331
R94	1 k Ω , \pm 5%, 1/4 W Resistor	110000-102
R95	15 k Ω \pm 5%, 1/4 W Resistor	110000-153
R96	100 k Ω \pm 5%, 1/4 W Resistor	110000-104
R97	68 Ω , \pm 5%, 1/4 W Resistor	110000-680
R98	2.2 k Ω \pm 5%, 1/4 W Resistor	110000-222
R99	120 Ω \pm 5%, 1/4 W Resistor	110000-121
R100	1 k Ω , \pm 5%, 1/4 W Resistor	110000-102
R101	1.0 k Ω , 1/2 W Vertical Trimming Potentiometer	119001-102
R102	3.9 k Ω \pm 5%, 1/4 W Resistor	110000-392
R103	1.2 k Ω \pm 5%, 1/4 W Resistor	110000-122
R104	5.1 k Ω \pm 5%, 1/4 W Resistor	110000-512
R105	10 k Ω , Horizontal Trimming Potentiometer	119002-103
R106	47 Ω , \pm 5%, 1/4 W Resistor	110000-470
R107	18 k Ω \pm 5%, 1/4 W Resistor	110000-183
R108, R109	510 Ω , \pm 5%, 1/4 W Resistor	110000-511

(continued on next page)

NTSC Demodulator PCB Assembly Parts List, continued

Designator	Description	Part No.
R110	3 k Ω \pm 5%, 1/4 W Resistor	110000-302
R111	100 Ω , \pm 5%, 1/4 W Resistor	110000-101
R112	47 Ω , \pm 5%, 1/4 W Resistor	110000-470
R113	220 Ω , \pm 5%, 1/4 W Resistor	110000-221
R114	1 k Ω , \pm 5%, 1/4 W Resistor	110000-102
R115	150 Ω , \pm 5%, 1/4 W Resistor	110000-151
R116	47 Ω , \pm 5%, 1/4 W Resistor	110000-470
R117	1 k Ω , \pm 5%, 1/4 W Resistor	110000-102
R118	2 k Ω \pm 5%, 1/4 W Resistor	110000-202
R119	1 k Ω , \pm 5%, 1/4 W Resistor	110000-102
R120	2 k Ω \pm 5%, 1/4 W Resistor	110000-202
R121	47 Ω , \pm 5%, 1/4 W Resistor	110000-470
R122, R123	1.2 k Ω \pm 5%, 1/4 W Resistor	110000-122
R124	270 Ω , \pm 5%, 1/4 W Resistor	110000-271
R125	1.2 k Ω \pm 5%, 1/4 W Resistor	110000-122
R126	240 Ω , \pm 5%, 1/4 W Resistor	110000-241
R127	2.7 k Ω \pm 5%, 1/4 W Resistor	110000-272
R128, R129	8.2 k Ω \pm 5%, 1/4 W Resistor	110000-822
R130, R131	10 Ω , \pm 5%, 1/4 W Resistor	110000-100
R132	3.9 k Ω \pm 5%, 1/4 W Resistor	110000-392
R133	5.1 k Ω \pm 5%, 1/4 W Resistor	110000-512
R134	1.2 k Ω \pm 5%, 1/4 W Resistor	110000-122
R135	10 k Ω , Horizontal Trimming Potentiometer	119002-103
R136	47 Ω , \pm 5%, 1/4 W Resistor	110000-470
R137	18 k Ω \pm 5%, 1/4 W Resistor	110000-183
R138, R139	510 Ω , \pm 5%, 1/4 W Resistor	110000-511
R140	3 k Ω \pm 5%, 1/4 W Resistor	110000-302
R150	100 Ω , \pm 5%, 1/4 W Resistor	110000-101
R151	47 Ω , \pm 5%, 1/4 W Resistor	110000-470
R152	220 Ω , \pm 5%, 1/4 W Resistor	110000-221
R153	1 k Ω , \pm 5%, 1/4 W Resistor	110000-102
R154	150 Ω , \pm 5%, 1/4 W Resistor	110000-151
R155	47 Ω , \pm 5%, 1/4 W Resistor	110000-470
R156	1 k Ω , \pm 5%, 1/4 W Resistor	110000-102
R157	2 k Ω \pm 5%, 1/4 W Resistor	110000-202
R158	1 k Ω , \pm 5%, 1/4 W Resistor	110000-102
R159	2 k Ω \pm 5%, 1/4 W Resistor	110000-202
R160	47 Ω , \pm 5%, 1/4 W Resistor	110000-470
R161-R163	1.2 k Ω \pm 5%, 1/4 W Resistor	110000-122
R164	270 Ω , \pm 5%, 1/4 W Resistor	110000-271
R165	240 Ω , \pm 5%, 1/4 W Resistor	110000-241
R166	2.7 k Ω \pm 5%, 1/4 W Resistor	110000-272
R167, R168	8.2 k Ω \pm 5%, 1/4 W Resistor	110000-822
R169, R170	10 Ω , \pm 5%, 1/4 W Resistor	110000-100
R171	3.9 k Ω \pm 5%, 1/4 W Resistor	110000-392
R172	5.1 k Ω \pm 5%, 1/4 W Resistor	110000-512

(continued on next page)

NTSC Demodulator PCB Assembly Parts List, continued

Designator	Description	Part No.
R173	1.2 k Ω \pm 5%, 1/4 W Resistor	110000-122
R174	10 k Ω , Horizontal Trimming Potentiometer	119002-103
R175	47 Ω , \pm 5%, 1/4 W Resistor	110000-470
R176	18 k Ω \pm 5%, 1/4 W Resistor	110000-183
R177	510 Ω , \pm 5%, 1/4 W Resistor	110000-511
R178	3 k Ω \pm 5%, 1/4 W Resistor	110000-302
R179	510 Ω , \pm 5%, 1/4 W Resistor	110000-511
R180	100 Ω , \pm 5%, 1/4 W Resistor	110000-101
R181	47 Ω , \pm 5%, 1/4 W Resistor	110000-470
R182	220 Ω , \pm 5%, 1/4 W Resistor	110000-221
R183	1 k Ω , \pm 5%, 1/4 W Resistor	110000-102
R184	150 Ω , \pm 5%, 1/4 W Resistor	110000-151
R185	47 Ω , \pm 5%, 1/4 W Resistor	110000-470
R186-R190	1 k Ω , \pm 5%, 1/4 W Resistor	110000-102
R191	2 k Ω \pm 5%, 1/4 W Resistor	110000-202
R192	1 k Ω , \pm 5%, 1/4 W Resistor	110000-102
R193	2 k Ω \pm 5%, 1/4 W Resistor	110000-202
R194	47 Ω , \pm 5%, 1/4 W Resistor	110000-470
R195-R197	1.2 k Ω \pm 5%, 1/4 W Resistor	110000-122
R198	270 Ω , \pm 5%, 1/4 W Resistor	110000-271
R199	240 Ω , \pm 5%, 1/4 W Resistor	110000-241
R200	2.7 k Ω \pm 5%, 1/4 W Resistor	110000-272
R201, R202	8.2 k Ω \pm 5%, 1/4 W Resistor	110000-822
R203, R204	10 Ω , \pm 5%, 1/4 W Resistor	110000-100
R205	15 Ω , \pm 5%, 10 W Wirewound Resistor	116000-150
R206	62 Ω , \pm 5%, 5 W Wirewound Resistor	116001-620
R207	120 Ω \pm 5%, 1/4 W Resistor	110000-121
R208	820 Ω , \pm 5%, 1/4 W Resistor	110000-821
R209	1 k Ω , \pm 5%, 1/4 W Resistor	110000-102
R210	3.9 k Ω \pm 5%, 1/4 W Resistor	110000-392
R211	240 Ω , \pm 5%, 1/4 W Resistor	110000-241
R212	130 k Ω \pm 5%, 1/4 W Resistor	110000-132
R213	500 Ω , Horizontal Trimming Potentiometer	119002-501
R214	15 Ω , \pm 5%, 5 W Flame-Proof Wirewound Resistor	116007-150
R215	200 Ω , Horizontal Trimming Potentiometer	119002-201
R216	560 Ω , \pm 5%, 1/4 W Resistor	110000-561
R218	510 Ω , \pm 5%, 1/4 W Resistor	110000-511
R219-R223	560 Ω , \pm 5%, 1/4 W Resistor	110000-561
R224	2.2 k Ω \pm 5%, 1/4 W Resistor	110000-222
R225-R227	910 Ω , \pm 5%, 1/4 W Resistor	110000-911
R228	5.1 k Ω \pm 5%, 1/4 W Resistor	110000-512
R229	220 Ω , \pm 5%, 1/4 W Resistor	110000-221
R230	150 Ω , \pm 5%, 1/4 W Resistor	110000-151
R231-R233	500 Ω , Horizontal Trimming Potentiometer	119002-501
R234	270 Ω , \pm 5%, 1/4 W Resistor	110000-271

(continued on next page)

NTSC Demodulator PCB Assembly Parts List, continued

Designator	Description	Part No.
R235	560 Ω , $\pm 5\%$, $\frac{1}{4}$ W Resistor	110000-561
R236	5 k Ω , Horizontal Trimming Potentiometer	119002-502
R237	47 Ω , $\pm 5\%$, $\frac{1}{4}$ W Resistor	110000-470
R238-R240	1 k Ω , $\pm 5\%$, $\frac{1}{4}$ W Resistor	110000-102
R241, R242	47 Ω , $\pm 5\%$, $\frac{1}{4}$ W Resistor	110000-470
R243-R245	100 Ω , $\pm 5\%$, $\frac{1}{4}$ W Resistor	110000-101
R246	150 Ω , $\pm 5\%$, $\frac{1}{4}$ W Resistor	110000-151
TP1	0 Ω (Dummy) Resistor	110005-001
W1	0 Ω (Dummy) Resistor	110005-001
W3, W4	0 Ω (Dummy) Resistor	110005-001
Transistors		
Q1	Type-2N3904, 60 V, 350 mW, NPN Switching Transistor	34-2N3904
Q2	Type-2N3906, 40 V, 1 W, PNP Transistor	33-2N3906
Q3	Type-2N3904, 60 V, 350 mW, NPN Switching Transistor	34-2N3904
Q4	Type-2N3906, 40 V, 1 W, PNP Transistor	33-2N3906
Q5, Q6	Type-2N3904, 60 V, 350 mW, NPN Switching Transistor	34-2N3904
Q7	25 V, 200 mA, NPN Transistor	133024-001
Q8-Q10	Type-2N3904, 60 V, 350 mW, NPN Switching Transistor	34-2N3904
Q11	Type-2N3906, 40 V, 1 W, PNP Transistor	33-2N3906
Q12	Type-2N3904, 60 V, 350 mW, NPN Switching Transistor	34-2N3904
Q13	Type-2N3823 N-Channel, VHF FET Transistor	133023-001
Q14	Type-2N3904, 60 V, 350 mW, NPN Switching Transistor	34-2N3904
Q15	Type-2N3906, 40 V, 1 W, PNP Transistor	33-2N3906
Q16	Type-2N3904, 60 V, 350 mW, NPN Switching Transistor	34-2N3904
Q17	Type-2N3823 N-Channel, VHF FET Transistor	133023-001
Q18	Type-2N3904, 60 V, 350 mW, NPN Switching Transistor	34-2N3904
Q19	Type-2N3906, 40 V, 1 W, PNP Transistor	33-2N3906
Q20	Type-2N3904, 60 V, 350 mW, NPN Switching Transistor	34-2N3904
Q21	Type-2N3823 N-Channel, VHF FET Transistor	133023-001
Q22	Type-2N3906, 40 V, 1 W, PNP Transistor	33-2N3906
Q23	Type-2N3904, 60 V, 350 mW, NPN Switching Transistor	34-2N3904
Q27	25 V, 100 mA NPN Transistor	133025-001
Q28	Type-2N3906, 40 V, 1 W, PNP Transistor	33-2N3906
Q29, Q30	Type-2N3904, 60 V, 350 mW, NPN Switching Transistor	34-2N3904
Q31	Type-2N3906, 40 V, 1 W, PNP Transistor	33-2N3906
Q32, Q33	Type-2N3904, 60 V, 350 mW, NPN Switching Transistor	34-2N3904
Q34	Type-2N3906, 40 V, 1 W, PNP Transistor	33-2N3906
Q35	Type-2N3643, 60 V, 300 mW, NPN Transistor	34-2N3643
Q36	Type-2N3644 PNP Transistor	34-2N3644
Q37, Q38	Type-2N3904, 60 V, 350 mW, NPN Switching Transistor	34-2N3904
Q39	Type-2N3906, 40 V, 1 W, PNP Transistor	33-2N3906
Q40, Q41	Type-2N3904, 60 V, 350 mW, NPN Switching Transistor	34-2N3904
Q42	Type-2N3906, 40 V, 1 W, PNP Transistor	33-2N3906

(continued on next page)

NTSC Demodulator PCB Assembly Parts List, continued

Designator	Description	Part No.
Q43	Type-2N3643, 60 V, 300 mW, NPN Transistor	34-2N3643
Q44	Type-2N3644 PNP Transistor	34-2N3644
Q45, Q46	Type-2N3904, 60 V, 350 mW, NPN Switching Transistor	34-2N3904
Q47	Type-2N3906, 40 V, 1 W, PNP Transistor	33-2N3906
Q48, Q49	Type-2N3904, 60 V, 350 mW, NPN Switching Transistor	34-2N3904
Q50	Type-2N3906, 40 V, 1 W, PNP Transistor	33-2N3906
Q51	Type-2N3643, 60 V, 300 mW, NPN Transistor	34-2N3643
Q52	Type-2N3644 PNP Transistor	34-2N3644
Q53	Type-2N3563 NPN Transistor	133027-001
Q54	Type-2N3906, 40 V, 1 W, PNP Transistor	33-2N3906
Q55	Type-2N3904, 60 V, 350 mW, NPN Switching Transistor	34-2N3904
Q57	25 V, 100 mA NPN Transistor	133025-001
Miscellaneous		
DL2	14-Circuit PC Mount, Receptacle Connector	179193-014
J11	7-Circuit, Right-Angle Connector Header	179165-007
J17	7-Circuit, Right-Angle Connector Header	179165-007
J18	50-Circuit, Right-Angle, 4-Wall Header Connector	179186-001
J19	#2-56x Self-Tapping Screw	72-6204S
J19	Right-Angle, PC Mount, BNC Receptacle Connector	179013-002
Y1	3.5795 MHz, HC-18/U Crystal	144007-01
TP1, TP2	Test Point (Acceptable substitute is part no. 020670-01)	179051-002
TP5-TP16	Test Point (Acceptable substitute is part no. 020670-01)	179051-002
TP18	Test Point (Acceptable substitute is part no. 020670-01)	179051-002
TP21-TP31	Test Point (Acceptable substitute is part no. 020670-01)	179051-002
	Snap-In Fastener	81-4302
	Standoff	178050-008

NOTICE TO ALL PERSONS RECEIVING THIS DRAWING
CONFIDENTIAL: Reproduction forbidden without the specific written permission of Atari, Inc., Sunnyvale, CA. This drawing is only conditionally issued, and neither receipt nor possession thereof conveys or transfers any right in, or license to use, the subject matter of the drawing or any design or technical information shown thereon, nor any right to reproduce this drawing or any part thereof. Except for manufacture by vendors of Atari, Inc., and for manufacture under the corporation's written license, no right is granted to reproduce this drawing or the subject matter thereof, unless by written agreement with or written permission from the corporation.

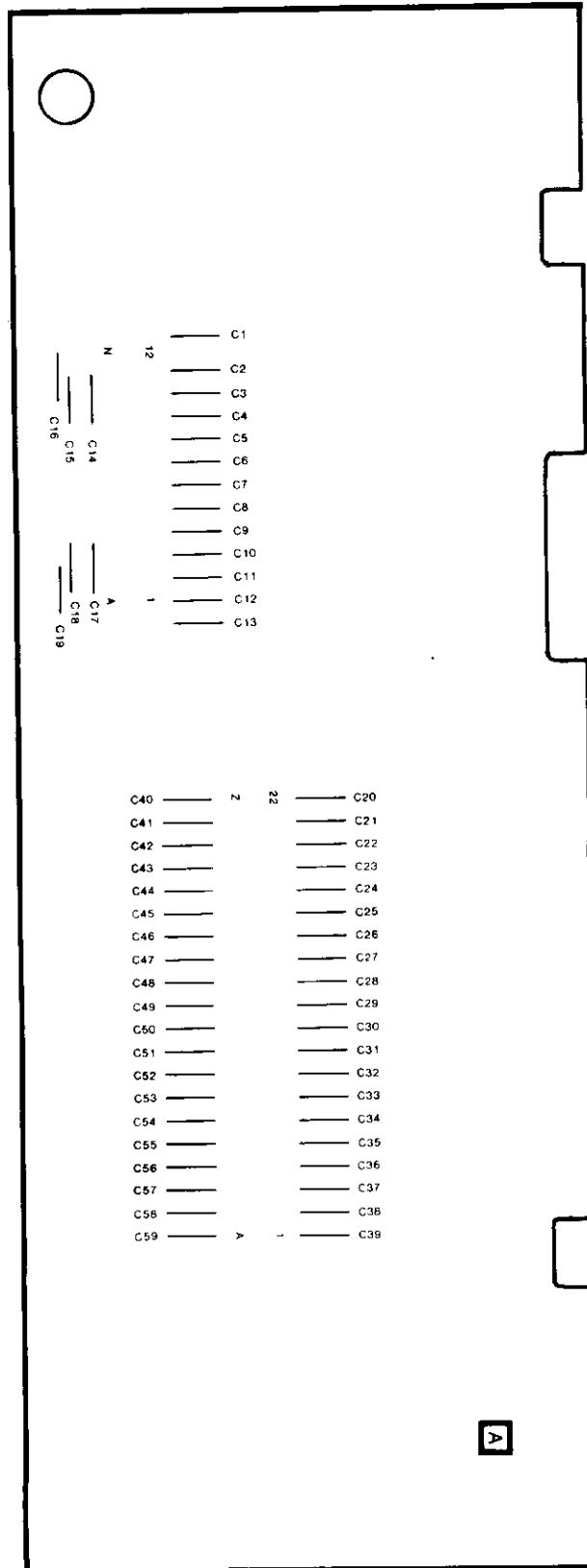

Figure 5-8 EMI Shield PCB Assembly
A040993-01 A

EMI Shield PCB Assembly Parts List

Designator	Description	Part No.
Capacitors		
C1	1000 pF, $\pm 5\%$, 100 V, NPO, Ceramic Axial-Lead Capacitor (Acceptable substitute is part no. 122002-102)	122016-102
C2-C12	0.1 μ F, +80% -20%, 50 V, Ceramic Capacitor	122002-104
C13	100 pF, 100 V, Ceramic Axial-Lead Capacitor (Acceptable substitute is part no. 122013-471)	122016-101
C14	0.1 μ F, +80% -20%, 50 V, Ceramic Capacitor	122002-104
C15, C16	1000 pF, $\pm 5\%$, 100 V, NPO, Ceramic Axial-Lead Capacitor (Acceptable substitute is part no. 122002-102)	122016-102
C17, C18	100 pF, 100 V, Ceramic Axial-Lead Capacitor (Acceptable substitute is part no. 122013-471)	122016-101
C19, C20	0.1 μ F, +80% -20%, 50 V, Ceramic Capacitor	122002-104
C21, C22	1000 pF, $\pm 5\%$, 100 V, NPO, Ceramic Axial-Lead Capacitor (Acceptable substitute is part no. 122002-102)	122016-102
C23-C26	0.01 μ F, +80% -20%, 25 V Minimum, Ceramic Axial-Lead Capacitor	122005-103
C27, C28	1000 pF, $\pm 5\%$, 100 V, NPO, Ceramic Axial-Lead Capacitor (Acceptable substitute is part no. 122002-102)	122016-102
C29, C30	0.01 μ F, +80% -20%, 25 V Minimum, Ceramic Axial-Lead Capacitor	122005-103
C31-C34	1000 pF, $\pm 5\%$, 100 V, NPO, Ceramic Axial-Lead Capacitor (Acceptable substitute is part no. 122002-102)	122016-102
C35	0.1 μ F, +80% -20%, 50 V, Ceramic Capacitor	122002-104
C36	1000 pF, $\pm 5\%$, 100 V, NPO, Ceramic Axial-Lead Capacitor (Acceptable substitute is part no. 122002-102)	122016-102
C37, C38	0.01 μ F, +80% -20%, 25 V Minimum, Ceramic Axial-Lead Capacitor	122005-103
C39, C40	0.1 μ F, +80% -20%, 50 V, Ceramic Capacitor	122002-104
C41, C42	1000 pF, $\pm 5\%$, 100 V, NPO, Ceramic Axial-Lead Capacitor (Acceptable substitute is part no. 122002-102)	122016-102
C43-C46	0.01 μ F, +80% -20%, 25 V Minimum, Ceramic Axial-Lead Capacitor	122005-103
C47, C48	1000 pF, $\pm 5\%$, 100 V, NPO, Ceramic Axial-Lead Capacitor (Acceptable substitute is part no. 122002-102)	122016-102
C49-C51	0.01 μ F, +80% -20%, 25 V Minimum, Ceramic Axial-Lead Capacitor	122005-103
C52, C53	1000 pF, $\pm 5\%$, 100 V, NPO, Ceramic Axial-Lead Capacitor (Acceptable substitute is part no. 122002-102)	122016-102
C54, C55	0.1 μ F, +80% -20%, 50 V, Ceramic Capacitor	122002-104
C56-C58	1000 pF, $\pm 5\%$, 100 V, NPO, Ceramic Axial-Lead Capacitor (Acceptable substitute is part no. 122002-102)	122016-102
C59	0.1 μ F, +80% -20%, 50 V, Ceramic Capacitor	122002-104
Connectors		
J16	44-Pin Edge Connector (Acceptable substitute is part no. 179046-044)	179073-044
J20	24-Pin Edge Connector	179073-024
Miscellaneous		
	Spacer	041799-01
	Spacer	041800-01
	#4-40 \times $\frac{1}{4}$ Cross-Recessed Pan-Head Screw	72-1404F
	$\frac{1}{4}$ -Inch Grommet	178044-242
	$\frac{1}{4}$ -Inch White Plunger	178045-442
	Flat Nylon Washer	175009-221

Upright Illustrated Parts Lists

This chapter provides information you need to order parts for your Upright game. When ordering parts, please give the part number, part name, number of this manual, and serial number of your game. This will aid in filling your order rapidly and correctly. We hope the results will be less downtime and more profit from your game.

Atari Customer Service numbers are listed on the inside front cover of this manual.



Chapter 6

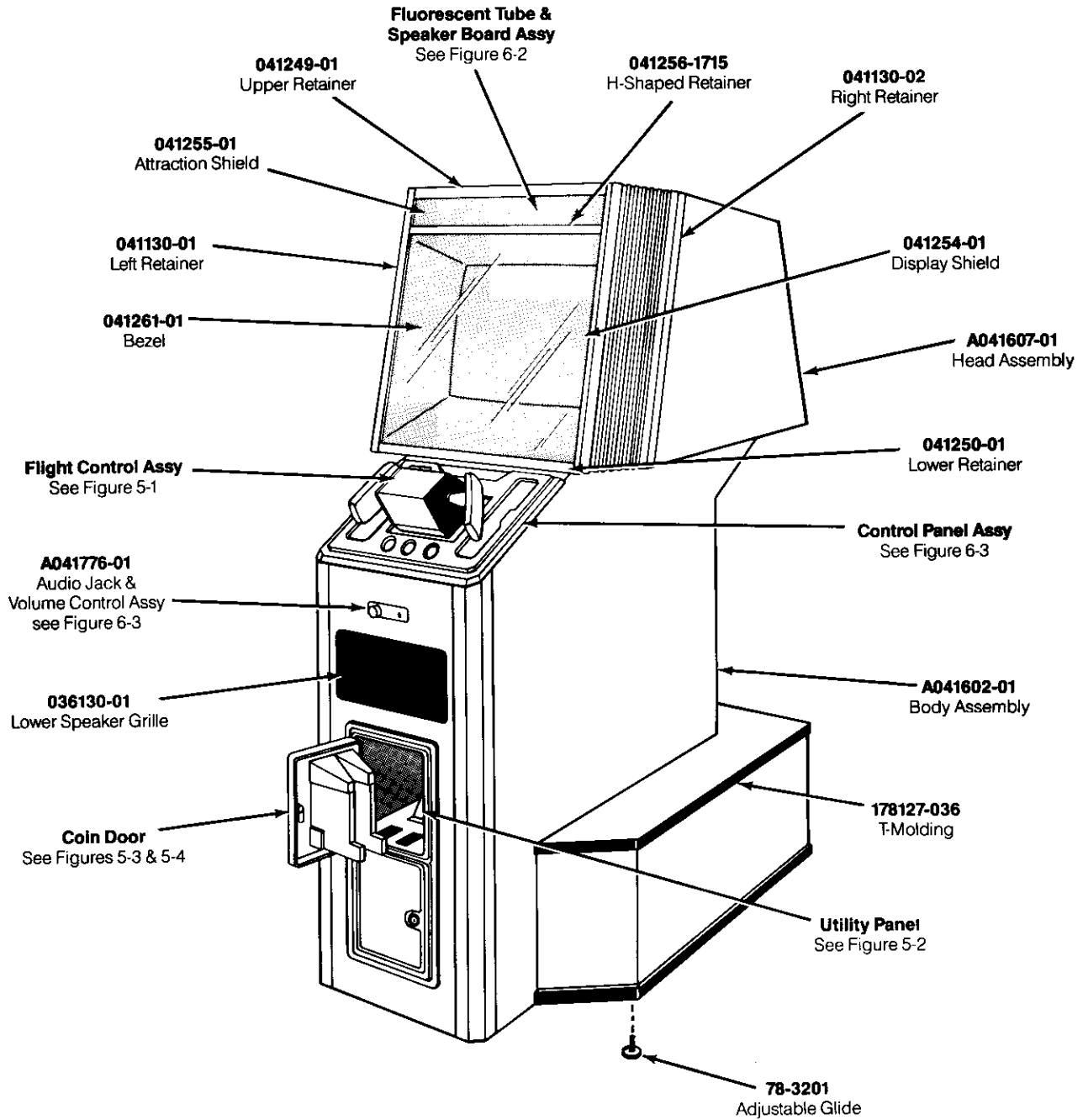

Game Documentation—
See parts list on next page

**Figure 6-1 Cabinet-Mounted Assemblies
A041600-xx B**

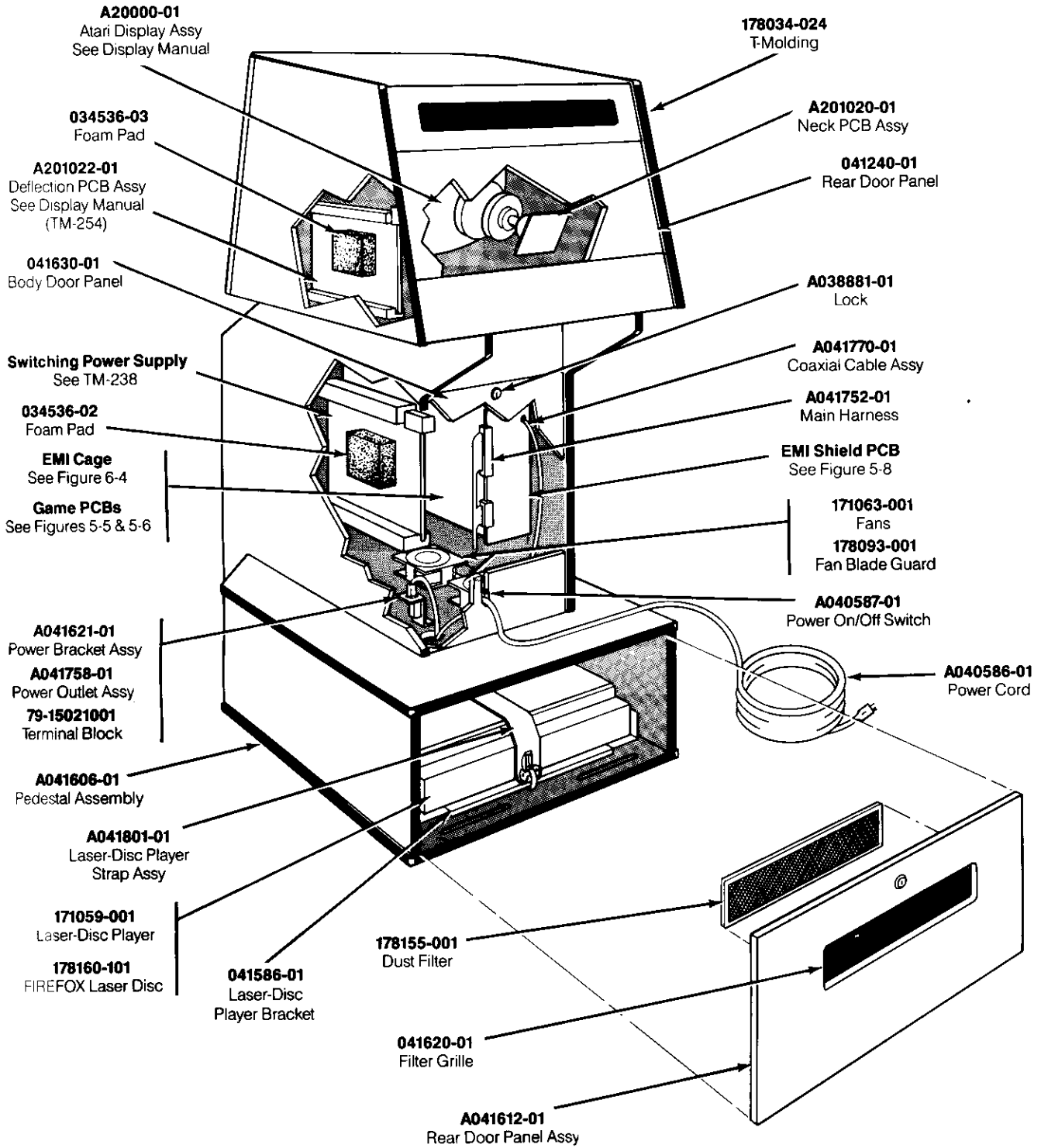

Figure 6-1 Cabinet-Mounted Assemblies, continued
A041600-xx B

Cabinet-Mounted Assemblies Parts List

Part No.	Description
A040586-01	Strain-Relief Power Cord (U.S. and Canada)
A038074-07	Switching Power Supply (see technical manual TM-238)
A040587-01	Power On/Off Switch, Harness, and Mounting Plate Assembly
A041587-01	Laser-Disc Player Mounting Assembly—consists of
72-HA4806S	#8-32 × 0.38-Inch Cross-Recessed Screw (not shown)
041586-01	Laser-Disc Player Mounting Bracket
178153-001	Shock Absorber Isolator (not shown)
A041601-01	Cabinet Assembly—consists of
A041602-01	Body Assembly
A041606-01	Pedestal Assembly
A041607-01	Head Assembly
A041612-01	Rear Door Panel Assembly for Pedestal—consists of
A038881-01	Lock (Acceptable substitute is part no. A038881-03)
041635-02	Rear Door Panel
041620-01	Filter Grille
A041621-01	Power Bracket Assembly—consists of
A041758-01	Power Outlet Assembly
72-HA460S	#6-32 × 3/8-Inch Cross-Recessed Thread-Forming Screw (not shown)
79-15021001	2-Position Terminal Block
041622-01	Power Bracket
A041752-01	Main Harness
A041753-01	Power Harness (not shown)
A041767-01	50-Circuit Ribbon Cable Assembly (not shown)—consists of
150023-050	50-Circuit Flat Ribbon Cable (not shown)
179192-050	50-Circuit Ribbon Connector (not shown)
A041769-01	Display Filter Assembly (not shown)—use only on Atari & Electrohome Displays—consists of
140000-002	11 μH, 2A, Line Filter (not shown)
78-2D1096	1½-Inch PVC Clear Tubing (not shown)
179053-000	18-22 AWG Socket Terminal (not shown)
179055-000	18-22 AWG Pin Terminal (not shown)
179056-002	2-Circuit Receptacle Connector (not shown)
179162-002	2-Circuit Plug Connector (not shown)
A041770-01	Coaxial Cable Assembly (connects to Video PCB, protrudes through EMI Shield PCB, and attaches to Laser-Disc Player)
A041801-01	Laser-Disc Player Strap Assembly—consists of
72-1104F	#10-24 × 0.25-Inch Cross-Recessed Pan-Head Screw (not shown)
78-6901202	Vinyl Foam Single-Coated Adhesive Tape 3/4-Inch Wide × 1/8-Inch Thick—6 inches required (not shown)
041585-01	Mounting Strap
178013-001	Tension Latch
A200001-01	Atari 19-Inch Color Raster-Scan Cathode-Ray Tube (CRT) Assembly—consists of
A201020-01	Neck PCB Assembly
A201022-01	Deflection PCB Assembly
201092-01	CRT Assembly (not shown)
A201024-01	Color Raster Harness Assembly (not shown)

(continued on next page)

Cabinet-Mounted Assemblies Parts List, continued

Part No.	Description
<i>The following five items are technical information supplements to this game:</i>	
TM-238	Switching Power Supply Technical Manual
SP-253	FIREFOX Schematic Package
ST-253	FIREFOX (Upright) Label with Self Test Procedure and Option Switch Settings
TM-253	FIREFOX Operators Manual
TM-254	Atari 19-Inch and 25-Inch Color Raster Display Manual
78-3201	Adjustable Glide
78-6900402	Vinyl Foam Single-Coated Adhesive Tape ¼-Inch Wide × ⅛-Inch Thick (36 inches required; used along top and bottom edge of display shield—not shown)
006008-04	Display Shield Extruded Plastic Molding (not shown)
009992-01	On/Off Switch Cover (not shown)
034536-02	½-Inch Thick Foam Pad (located between the Power Supply PCB and the cabinet wall)
034536-03	1.12-Inch Thick Foam Pad (located between the Deflection PCB and the cabinet wall)
036130-01	Lower Speaker Grille
038091-01	Molded Coin Box (not shown)
038870-01	Coin Box Enclosure (not shown)
041130-01	Left Retainer (Metal Extrusion)
041130-02	Right Retainer (Metal Extrusion)
041240-01	Rear Door Panel for Head Assembly
041250-01	Display Shield Lower Retainer
041251-01	Ventilation Grille (located in floor of head assembly) (not shown)
041254-01	Display Shield
041255-01	Attraction Panel
041261-01	Video Display Bezel
041630-01	Rear Door Panel for Body Assembly (includes lock)
041618-02	Semi-Rigid Attraction Film with Graphics (not shown)
148004-002	5-Inch, 4-Ω, 6-Ounce Shielded High-Fidelity Speaker (located below control panel—not shown)
171059-001	Laser-Disc Player
171063-001	110 V, 60 Hz Exhaust Fan
178013-001	Spring-Draw Latch (not shown)
178034-024	¾-Inch Black Plastic T-Molding (21 inches required on front of pedestal base; 168 inches required on the side panels of the head assembly; 104 inches required on the side panels of the body assembly; 94 inches required on the front panel of the body assembly)
178093-001	Guard for Fan Blade
178127-036	2 ¼-Inch Black Plastic T-Molding (68 inches required on the pedestal)
178155-001	¼-Inch Thick, 5 Ply Dust Filter (located on rear door panel of pedestal)
178160-101	FIREFOX Laser Disc
179125-001	Grounding Clip on Main Harness (not shown)
201018-01	19-Inch CRT Bracket (not shown)

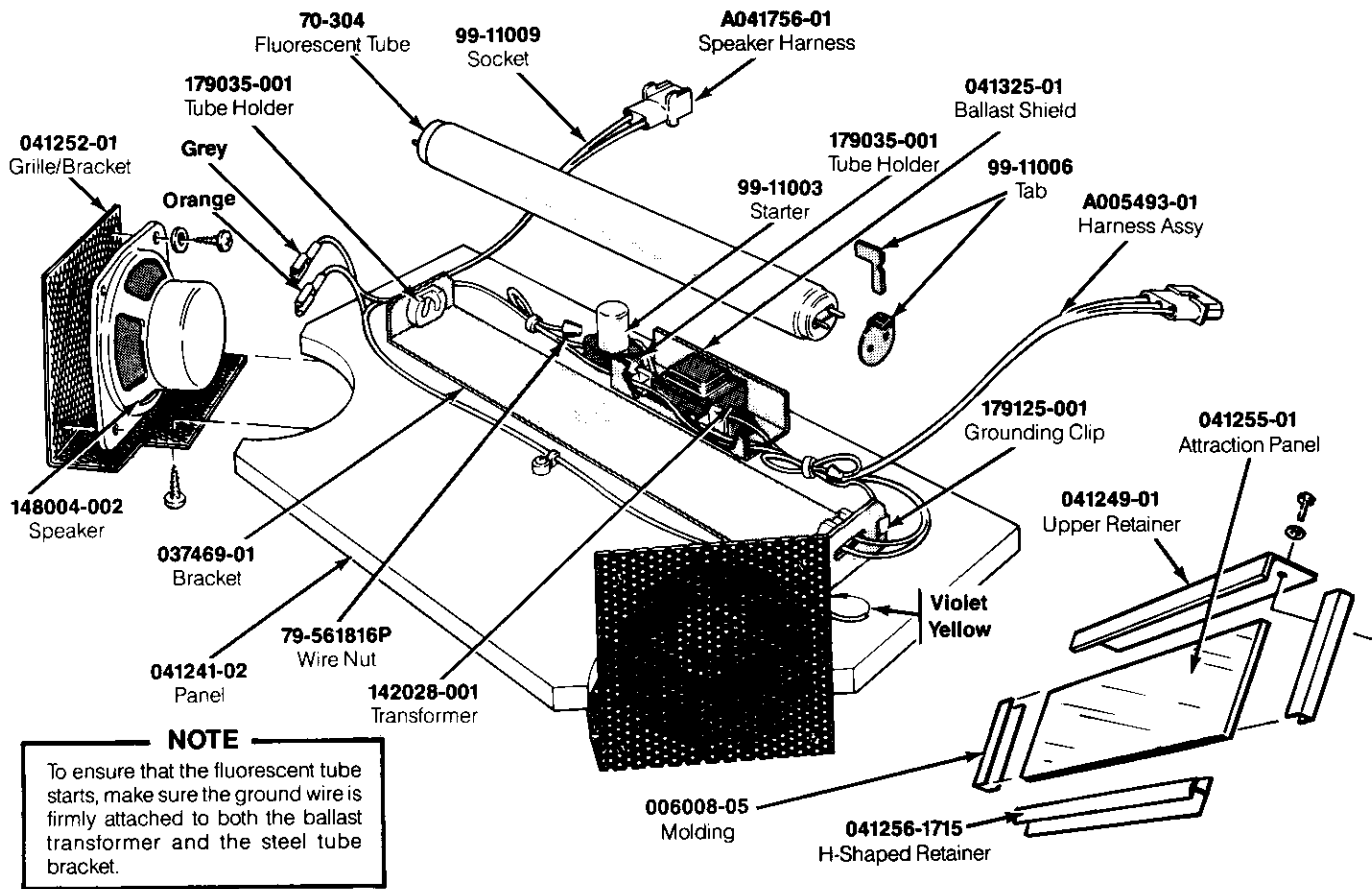

**Figure 6-2 Attraction Panel, Fluorescent Tube, and Speaker Assembly
A041610-01 A
Parts List**

Part No.	Description
A005493-01	Fluorescent Tube Harness Assembly
A037540-01	Ground Wire with Ring Lug
A041756-01	Speaker Harness Assembly
70-304	18-Inch, 15-Watt, Cool White Fluorescent Tube
79-561816P	Spring-Connector Wire Nut for 16- to 18-Gauge Wires
99-11003	Fluorescent Tube Starter
99-11006	Fluorescent Tube Locking Tab (consists of two pieces)
99-11009	Starter Socket
006008-05	Attraction Glass Extruded Plastic Molding
037469-01	Steel Tube Bracket
041241-02	Wood Mounting Panel
041249-01	Attraction Shield Upper Retainer
041252-01	Speaker Mounting Grille/Bracket
041255-01	Attraction Panel
041256-1715	H-Shaped Retainer for Attraction Glass and Display Shield
041325-01	Ballast Shield
142028-001	60 Hz, 118 V, Ballast Transformer
148004-002	5-Inch Diameter, 5 W, 4 Ω, Shielded Speaker
179035-001	2-Pin Fluorescent Tube Holder
179125-001	Grounding Clip (Acceptable substitute is part no. 179174-010)

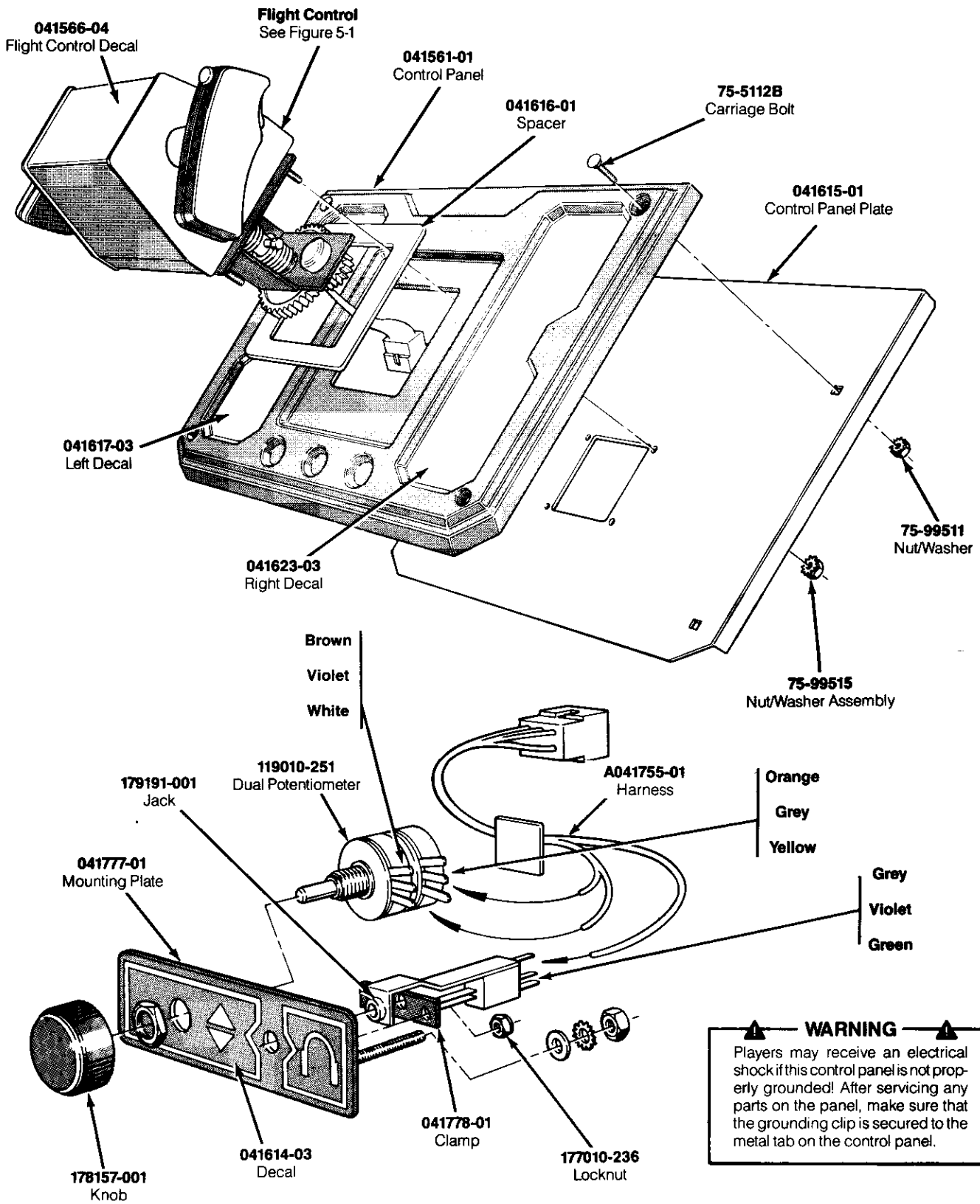

**Figure 6-3 Control Panel Assembly A041611-01 A
Audio Jack Assembly A041776-01 A**

Control Panel and Audio Jack Assemblies Parts List

Part No.	Description
A040233-01	Flight Control
A041776-01	Audio Jack & Volume Control Assembly—consists of
A041755-01	Harness (includes connector)
041614-03	Decal for Audio Jack Plate
041777-01	Audio Jack Mounting Plate
041778-01	Audio Jack Clamp
119010-251	250 Ω Dual Potentiometer
177010-236	#6-32 Polymer Hex Locknut
178157-001	Volume Control Knob
179191-001	3.5 mm Jack
75-5112B	#10-24 \times 0.75-Inch Carriage Bolt
75-99511	Nut/Washer Assembly
75-99515	# $\frac{1}{4}$ \times 20 Nut/Washer Assembly
041561-01	Control Panel
041566-04	Flight Control Decal
041615-01	Control Panel Plate
041616-01	Spacer for Flight Control
041617-03	Left Decal for Control Panel Plate
041623-03	Right Decal for Control Panel Plate

NOTE
 Within the United States, the Federal Communications Commission requires that the game printed-circuit boards be housed in the Electromagnetic Interference Cage with the Electromagnetic Interference Shield printed-circuit board attached.

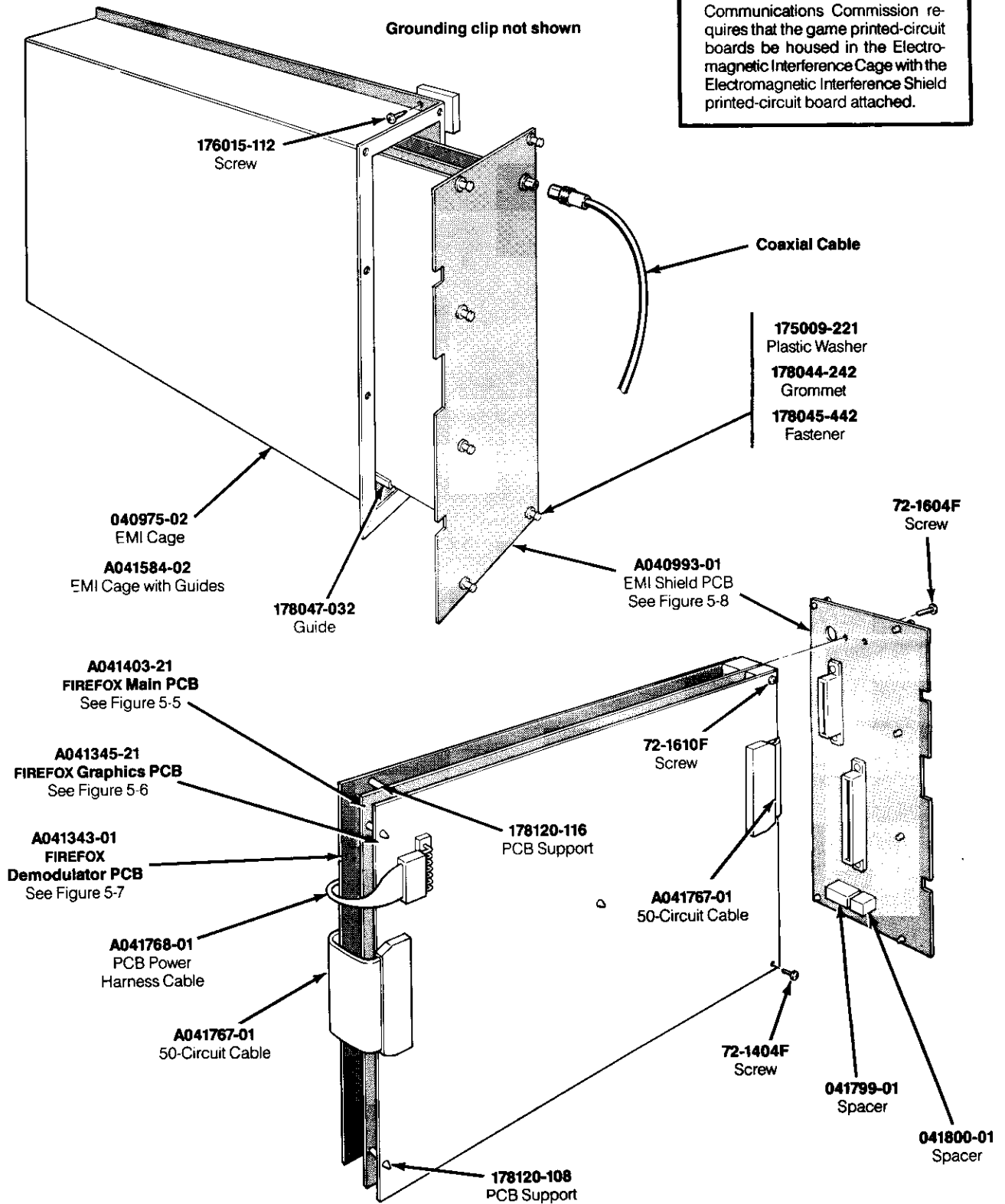
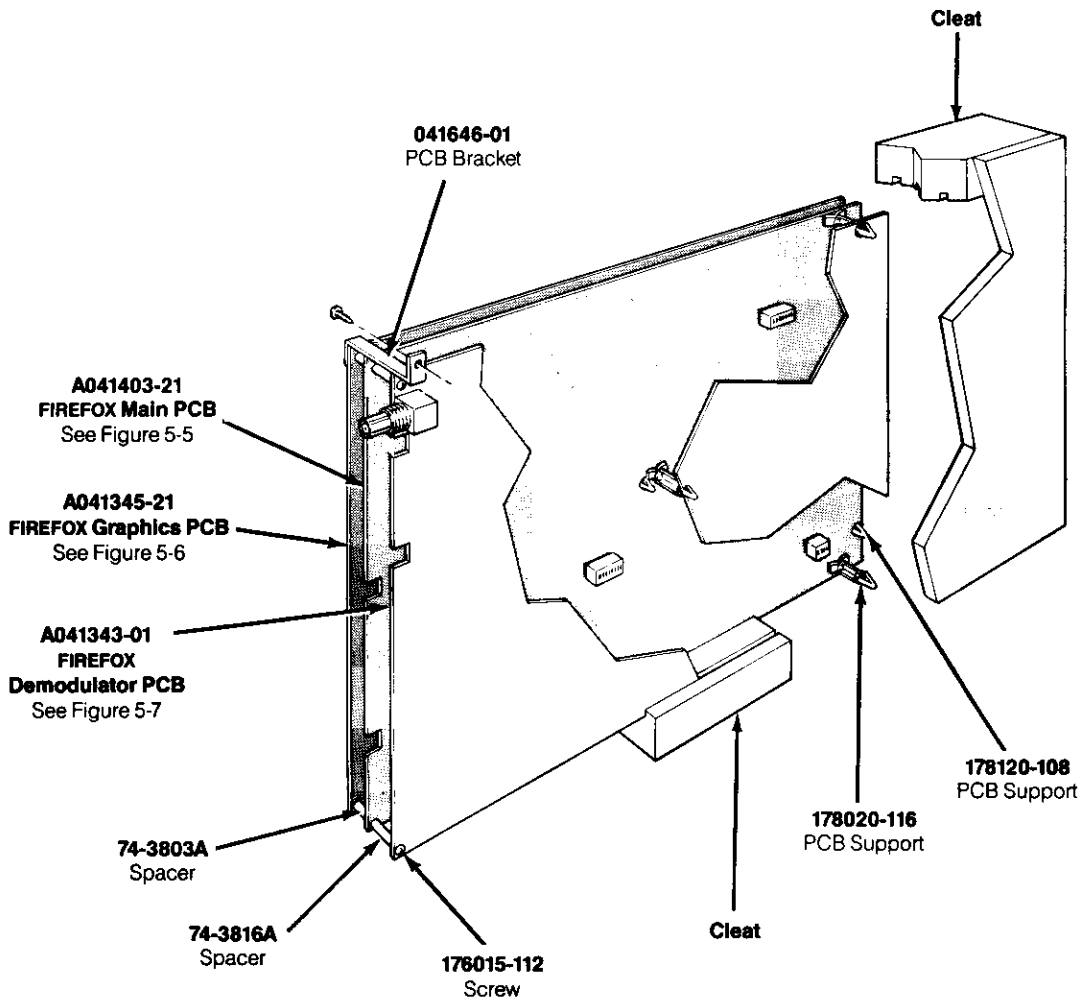

Figure 6-4 PCB Mounting Hardware—US

Figure 6-4 PCB Mounting Hardware—US, continued Parts List

Part No.	Description
A040993-01	EMI Shield PCB Assembly—includes
72-1404F	#4-40 × ¼-Inch Cross-Recessed Steel Screw
041799-01	Spacer
041800-01	Spacer
175009-221	Plastic Washer
178044-242	Grommet
178045-442	Snap-In Fastener
A041343-01	FIREFOX Demodulator PCB
A041345-21	FIREFOX Graphics PCB
A041403-21	FIREFOX Main PCB
A041584-02	EMI Cage with Guides
040975-02	EMI Cage
178047-032	16-Inch Snap-In PCB Guide (six required)
A041767-01	50-Circuit Ribbon Cable
A041768-01	PCB Power Harness Cable
A041768-02	PCB Power Harness Cable (connects Main PCB to Demodulator PCB) (not shown)
72-1604F	#6-32 × ¼-Inch Cross-Recessed Pan-Head Screw
72-1610F	#6-32 × ⅝-Inch Cross-Recessed Pan-Head Screw
175004-708	#8 Flat Fiber Washer
176015-112	#10 × ¾-Inch Cross-Recessed Pan-Head Screw
178120-108	⅝-Inch PCB Support (located between the Graphics and the Main PCB)
178120-116	1-Inch PCB Support (located between the Main and the Demodulator PCB)
178149-607	Nylon Standoff



**Figure 6-5 PCB Mounting Hardware—Ireland
Parts List**

Part No.	Description
A041343-01	FIREFOX Demodulator PCB
A041345-21	FIREFOX Graphics PCB
A041403-21	FIREFOX Main PCB
74-3803A	¾-Inch Aluminum Spacer
74-3816A	1-Inch Aluminum Spacer
041646-01	PCB Bracket
178120-108	¾-Inch PCB Support (located between the Graphics and the Main PCB)
178120-116	1-Inch PCB Support (located between the Main and the Demodulator PCB)
176015-112	#10 × ¾-Inch Cross-Recessed Pan-Head Screw

Sit-Down Illustrated Parts Lists

This chapter provides information you need to order parts for your Sit-Down game. When ordering parts, please give the part number, part name, number of this manual, and serial number of your game. This will aid in filling your order rapidly and correctly. We hope the results will be less downtime and more profit from your game.

Atari Customer Service numbers are listed on the inside front cover of this manual.

NOTE

The information for the FIREFOX sit-down cabinet was unavailable for the first printing.

