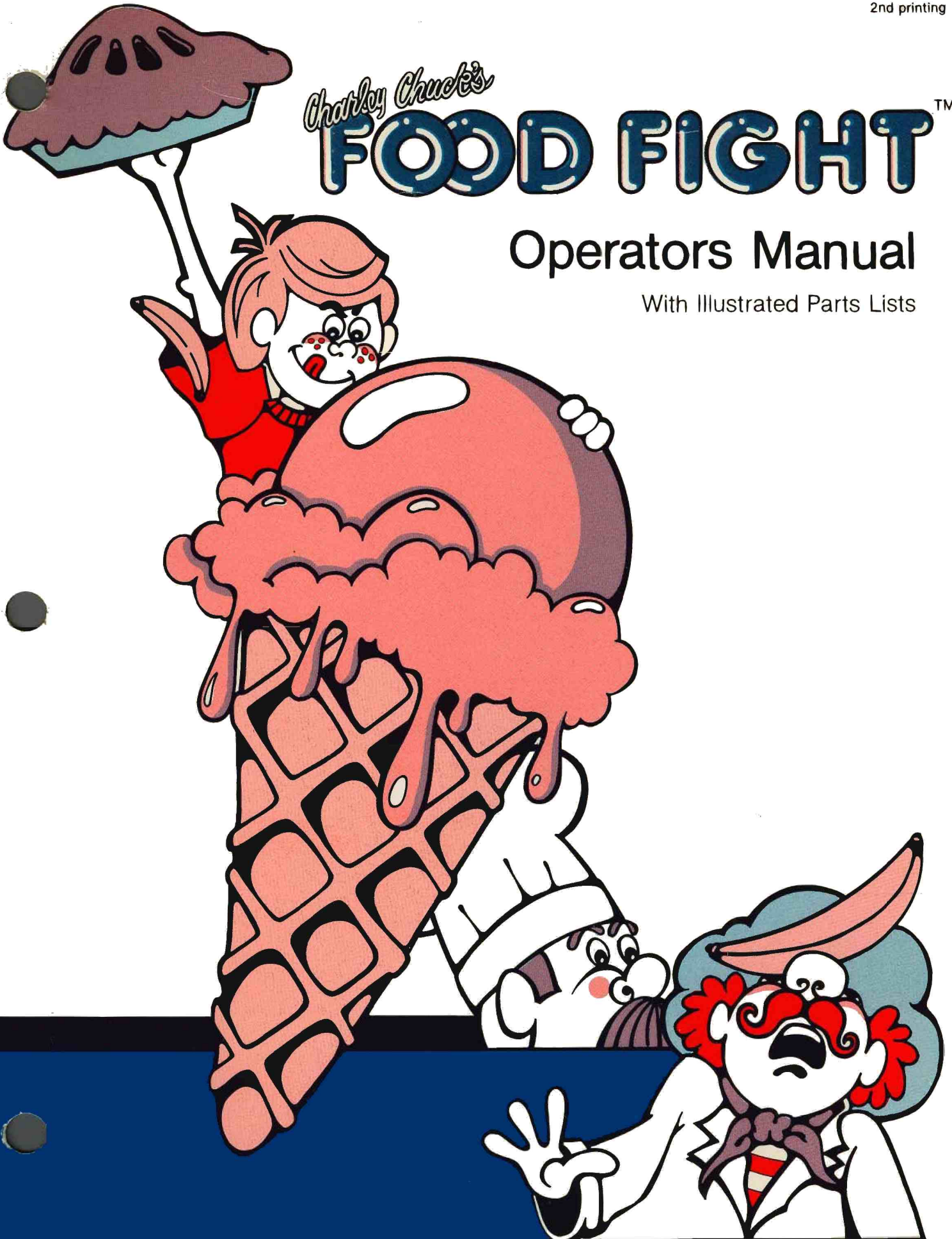


Charley Chuck's

FOOD FIGHT™

Operators Manual

With Illustrated Parts Lists





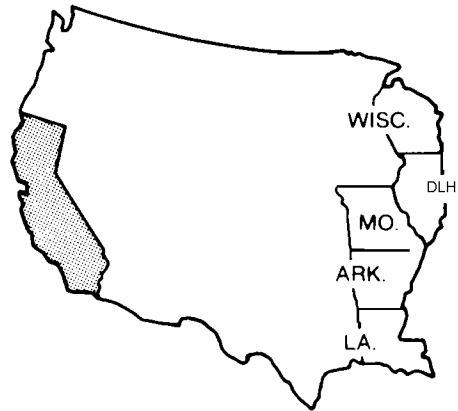
If reading through this manual does not lead to solving a certain maintenance problem, call TELEHELP® at the Atari Customer Service office in your geographical area, as shown below.

WEST and CENTRAL U.S.A.

Parts and Service

Atari, Inc.
California Customer Service Office
1105 N. Fair Oaks Avenue
P. O. Box 427, Sunnyvale, CA 94086
Telex 17-1103
(Monday-Friday, 7:30-4:00 pm Pacific Time)



-  From California, Alaska, or Hawaii
(408) 745-2900
-  Service from anywhere in the area shown in white
toll-free (800) 538-1611

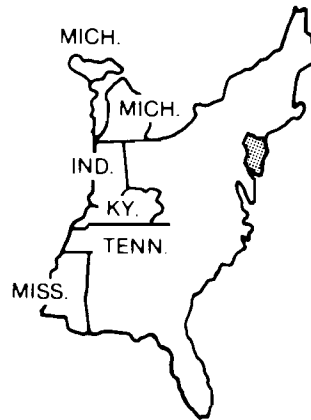


EAST U.S.A.

Service only

Atari, Inc.
New Jersey Customer Service Office
12A World's Fair Drive, Somerset, NJ 08873
Telex 37-9347
(Monday-Friday, 7:30-4:00 pm Eastern time)


-  From New Jersey
(201) 469-5993
-  From anywhere else in this area
toll-free (800) 526-3849

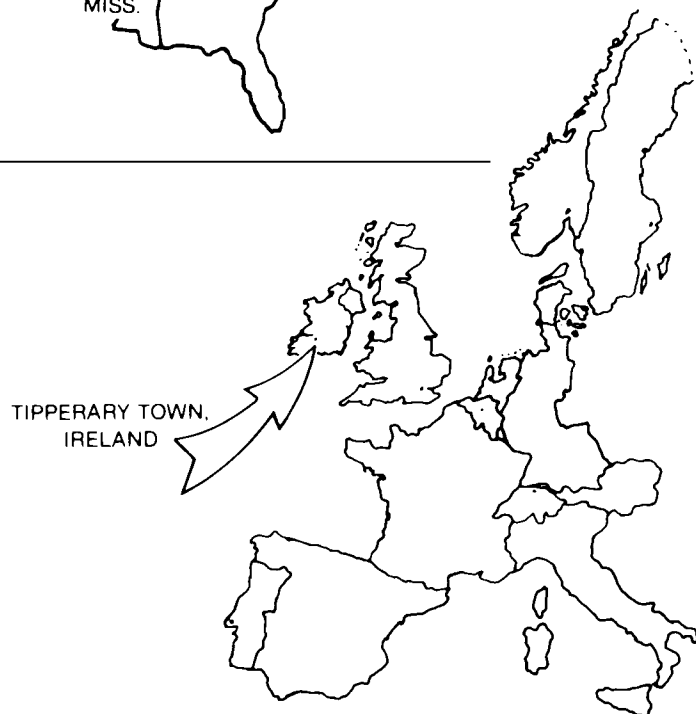


EUROPE

Parts and Service

Atari Ireland Limited
European Customer Service Office
Tipperary Town, Ireland
Telex 28-165
(Monday-Friday, 9:00-6:00 pm GMT)

-  062-52155



Charley Chuck's

FOOD FIGHT



© 1983 by Atari, Inc.

All rights reserved.

No part of this publication may be reproduced by any mechanical, photographic, or electronic process, or in the form of a phonographic recording, nor may it be stored in a retrieval system, transmitted, or otherwise copied for public or private use, without permission from the publisher.

The game play, all graphic designs, this technical manual, its accompanying schematic diagrams, and the display manual are protected by the U.S. Copyright Act of 1976.

This Act provides for increased penalties for violating federal copyright laws. Courts *can impound* infringing articles while legal action is pending. If infringers are convicted, courts can *order destruction* of the infringing articles.

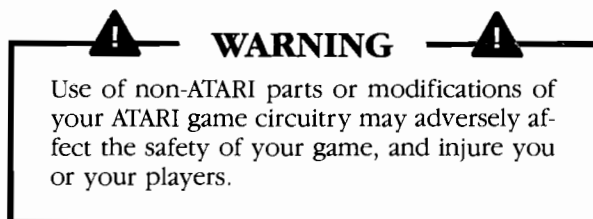
In addition, the Act provides for payment of statutory damages of up to \$50,000 in certain cases. Infringers may also have to pay costs and attorneys' fees, fines up to \$25,000, and face an imprisonment of up to one year.

Atari will aggressively enforce its copyrights against any infringers. *We will use all legal means* to immediately halt any manufacture, distribution, or operation of a copy of video games made by us. Anyone who purchases such copies risks forfeiting such a game.

Published by:
ATARI, INC.
790 Sycamore Drive
P.O. Box 906
Milpitas, California 95035

Printed in the U.S.A. 3M

Notice Regarding Non-ATARI Parts



You may void the game warranty (printed on the inside back cover of this manual) if you do any of the following:

- substitute non-ATARI parts in the game
- modify or alter any circuits in the game by using kits or parts *not* supplied by Atari.

Note

This equipment generates, uses, and can radiate radio frequency energy and if not installed and used in accordance with the instruction manual, may cause interference to radio communications. It has been tested and found to comply with the limits for a Class A computing device pursuant to Subpart J of Part 15 of Federal Communications Commission (FCC) Rules, which are designed to provide reasonable protection against such interference when operated in a commercial environment. Operation of this equipment in a residential area or modification to this equipment is likely to cause interference in which case the user, at his own expense, will be required to take whatever measures may be required to correct the interference. If you suspect interference from an ATARI® game at your location, check the following:

- All green ground wires in the game are properly connected as shown in the game wiring diagram.
- The power cord is properly plugged into a grounded three-wire outlet.
- The game printed-circuit board(s) (PCB) is properly installed within the Electromagnetic Interference (EMI) cage.
- The EMI Shield PCB is properly installed and connected in series with the game PCB harness.
- All filter capacitors required on the EMI Shield PCB are properly soldered in place.

If you are still unable to solve the interference problem, please contact ATARI Customer Service. See the inside front cover of this manual for service in your area.

Table of Contents

1 Set-Up Procedures

A. How to Use This Manual	1-1
B. Game Overview	1-4
C. Installation Specifications	1-4
D. Inspecting the Game	1-4
E. Voltage-Plug Selection and Fuses	1-5
F. Switch Locations	1-6
1. Power On/Off Switch	1-6
2. Utility Panel Switches	1-6
3. Option Switches	1-6
G. Selecting the Coin and Credit Options	1-6

2 Self-Test Procedure

A. Self-Test Display	2-2
B. Self-Test Menu	2-3
C. Selecting the Options	2-6

3 Illustrated Parts Lists

Parts lists begin on page	3-2
-------------------------------------	-----

Appendix A

Gimbal Joystick Maintenance	A-1
---------------------------------------	-----

List of Illustrations

Figure 1-1	Game Overview, US-Built Game	1-2
Figure 1-2	Game Overview, Ireland-Built Game	1-3
Figure 1-3	Voltage-Selection Plug and Fuse Locations	1-5
Figure 1-4	Option Switch Locations	1-6
Figure 2-1	Main Self-Test Menu	2-3
Figure 2-2	Hardware Tests Menu	2-3
Figure 2-3	Switch Test Display	2-4
Figure 2-4	Color Pattern	2-4
Figure 2-5	Convergence Pattern	2-4
Figure 2-6	Statistics Display	2-5
Figure 2-7	Options Display	2-6
Figure 3-1	Cabinet-Mounted Assemblies, US-Built Game	3-2
Figure 3-2	Cabinet-Mounted Assemblies, Ireland-Built Game	3-4
Figure 3-3	Control Panel Assembly	3-6
Figure 3-4	Gimbal Joystick Assembly	3-8
Figure 3-5	Fluorescent Tube and Speaker, US-Built Game	3-10
Figure 3-6	Fluorescent Tube and Attraction Panel, Ireland-Built Game	3-12
Figure 3-7	Video Display, US-Built Game	3-13
Figure 3-8	Video Display, Ireland-Built Game	3-14
Figure 3-9	Utility Panel Assembly	3-15
Figure 3-10	Vertically Mounted Coin Door	3-16
Figure 3-11	American-Made Coin Door	3-19
Figure 3-12	Electromagnetic Interference (EMI) Cage Assembly and PCB Mounting Hardware	3-22
Figure 3-13	EMI Shield PCB Assembly	3-24
Figure 3-14	Food Fight Game PCB	3-26
Figure 3-15	Regulator/Audio II PCB Assembly	3-33
Figure 3-16	Color Raster-Scan Power Supply Assembly	3-36
Figure A-1	Disassembling the Pivot Shaft Assembly	A-1

List of Tables

Table 1-1	Installation Specifications	1-4
Table 1-2	Switch Settings for Price and Bonus Options	1-7
Table 2-1	Playfield RAM Locations	2-2
Table 2-2	Program RAM Locations	2-2
Table 2-3	Program ROM Locations	2-2
Table 2-4	Sound Chip Locations	2-4
Table 2-5	Option Settings	2-6

Safety Summary

The following safety precautions apply to all game operators and service personnel. Specific warnings and cautions will be found throughout this manual where they apply.

WARNINGS

Properly Ground the Game. Players may receive an electrical shock if this game is not properly grounded! To avoid electrical shock, do not plug in the game until it has been inspected and properly grounded. This game should only be plugged into a grounded 3-wire outlet. If you have only a 2-wire outlet, we recommend you hire a licensed electrician to install a grounded outlet.

Players may receive an electrical shock if the control panel, video display, EMI cage, fluorescent light assembly, and utility panel are not properly grounded! After servicing, check that the green ground wire or grounding clip for each assembly is firmly attached. Only then should you lock up the game.

AC Power Connection. Before connecting the game to the AC power source, verify that the proper voltage-selection plug is installed on the game's power supply.

Disconnect Power During Repairs. To avoid electrical shock, disconnect the game from the AC power source before removing or repairing any part of the game.

Discharge High Voltage from the Video Display. When removing or repairing the video display, extra precautions must be taken to avoid electrical shock. High voltages may exist within the display circuitry and cathode-ray tube (CRT) even after power has been disconnected. Do not touch internal parts of the display with your hands or with metal objects held in your hands! Always discharge the high voltage from the CRT before servicing this area of the game. To discharge the CRT: Attach one end of a large, well-insulated, 18-gauge jumper wire to ground. Momentarily touch the free end of the grounded jumper to the anode by sliding it under the anode cap. Wait two minutes and discharge the anode again.

Use Only ATARI Parts. To maintain the safety integrity of your ATARI game, use only ATARI authorized parts when repairing the game. Use of non-ATARI parts or modifications of the game circuitry may adversely affect the safety of your game, void the warranty, and injure you or your players.

Handle Fluorescent Tube and CRT With Care. If you drop a fluorescent tube or CRT and it breaks, it will implode! Shattered glass can fly six feet or more from the implosion.

Use the Proper Fuses. To avoid electrical shock, only use replacement fuses that are specified in the parts list for this game. Replacement fuses must match those replaced in fuse type, voltage rating, and current rating. In addition, the fuse cover must be in place during game operation.

CAUTION

Properly Attach All Connectors. Before turning on the game for the first time, make sure that all connectors are properly attached. Make sure that the connectors on each PCB are properly plugged in. Note that they are keyed to fit only one way. If they do not slip on easily, do not force them. A reversed connector may damage your game and void the warranty.

Set-Up Procedures



A. How to Use This Manual

This manual, written for game operators and service technicians, describes the Food Fight™ game. The manual contains information about both the Ireland- and US-built games. Whenever information is unique to the Ireland-built game, this symbol appears: ♣

Whenever information is unique to the US-built game, this symbol appears: ★

Chapter 1 contains game specifications, inspection procedures, voltage plug and fuse information, switch locations, and option information.

Chapter 2 contains self-test procedures.

Chapter 3 contains illustrated parts lists. Figures 3-1 and 3-2 illustrate the US-built and the Ireland-built game cabinet. Italicized type on these figures refer you to other places in the manual for information about specific cabinet parts.

Schematic diagrams of the game circuitry are included as a supplement to this manual.

Chapter 1

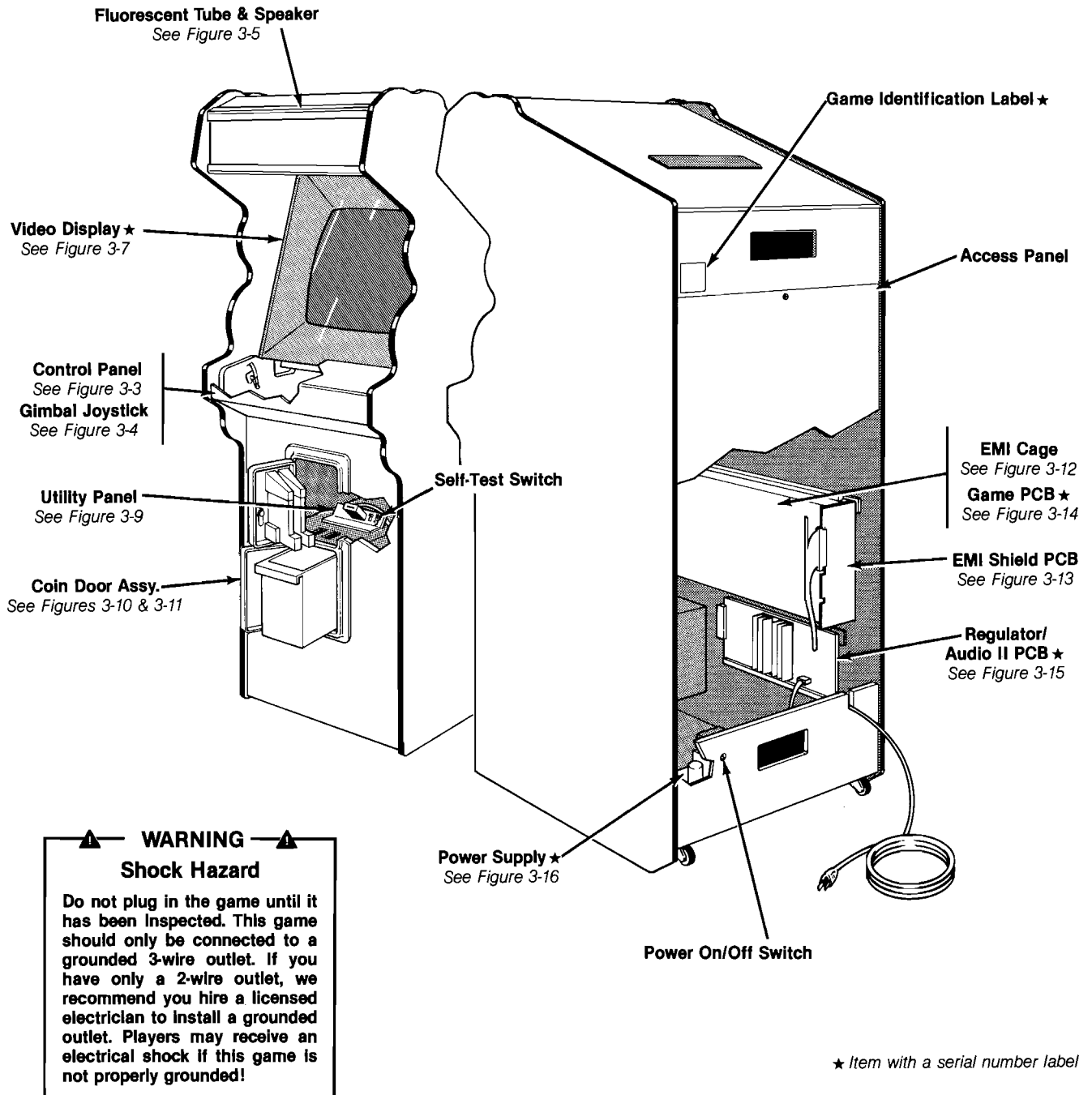


Figure 1-1 Game Overview—US-Built Game

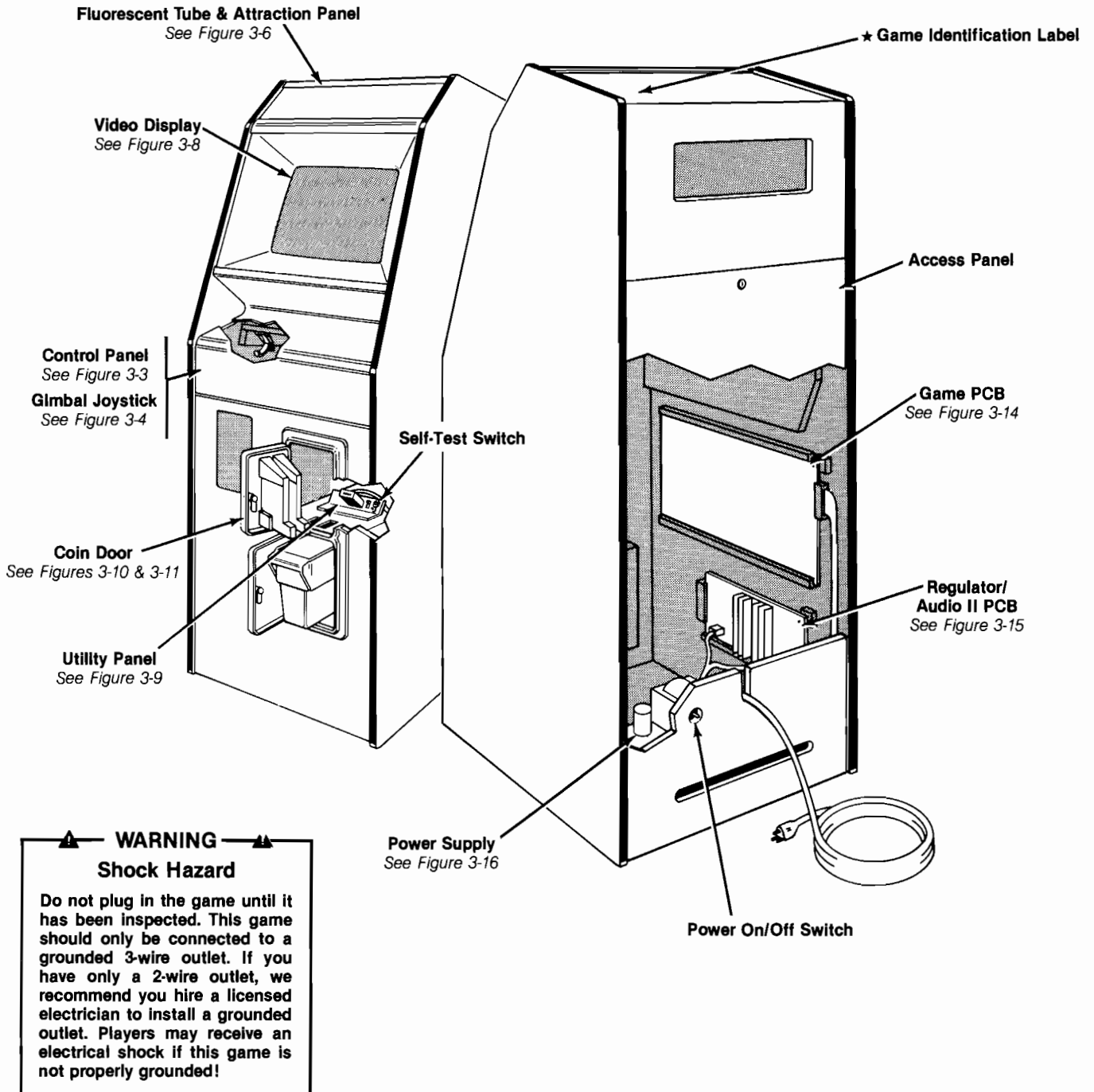


Figure 1-2 Game Overview—Ireland-Built Game

B. Game Overview

Food Fight hero, Charley Chuck, gets points by eating his ice cream cone before it melts. To do this, he must fight off Oscar, Angelo, Jacques, and Zorba, the four chefs who rise from holes and throw food at him. When Chuck eats the cone, the ice-cream flavor changes and the game difficulty increases.

All major parts of the US-built Food Fight game are illustrated in Figure 1-1. All major parts of the Ireland-built game are illustrated in Figure 1-2.

C. Installation Specifications

Table 1-1 describes the physical, electrical, and environmental specifications of the game.

Table 1-1 Installation Specifications

Power Consumption	200 W
Temperature	0 to +38° C (+32 to +100° F)
Humidity	Not to exceed 95% relative
Line Voltage	100 to 240 VAC
<i>US-Built Cabinet</i>	
Width	62.5 cm (25.5 in.)
Depth	86 cm (34 in.)
Height	181.5 cm (72 in.)
<i>Ireland-Built Cabinet</i>	
Width	60 cm (24 in.)
Depth	68 cm (27 in.)
Height	170 cm (67 in.)

D. Inspecting the Game

Please inspect your game carefully to ensure that it was delivered to you in good condition.

WARNING

Shock Hazard

To avoid electrical shock, do not plug in the game until the procedures in Sections D and E have been completed!

Do not touch internal parts of the display with your hands or with metal objects held in your hands!

1. Examine the exterior of the game cabinet for dents, chips, or broken parts.
2. Remove the screws from the rear access panel. Unlock and open this panel and the coin door; inspect the interior of the game as follows:
 - a. Ensure that all plug-in connectors (on the game harnesses) are firmly plugged in. Replug any connectors found unplugged. Do not force connectors together. The connectors are keyed so they only fit in the proper orientation. *A reversed edge connector may damage a PCB and will void your warranty.*
 - b. Ensure that all plug-in integrated circuits on the PCB are firmly plugged into their sockets.
 - c. Remove the tie-wrap that secures the coiled power cord inside the cabinet. Inspect the power cord for any cuts or dents in the insulation. Repair or replace it as required. Place the square strain-relief plate in the wood slot at the bottom of the rear panel opening.
 - d. Inspect major subassemblies, such as the power supply, control panel, video display, and EMI cage. Make sure they are mounted securely and that the green ground wires are connected.



E. Voltage-Plug Selection and Fuses

The power supply in your game contains six fuses. When you replace a fuse, use the identical type fuse with the same electrical rating (see Figure 1-3).

This power supply operates on the line voltage of many countries. The power supply comes with either one, two, or three voltage-selection plugs. Plug voltages and wire

colors are 100 VAC (violet wire color), 120 VAC (yellow wire color), 220 VAC (blue wire color), and 240 VAC (brown wire color).

See Figure 1-3 for placement of the voltage-selection plug. Before plugging in your game, check your line voltage. Next, check the wire color on the voltage-selection plug. Make sure the voltage-selection plug is correct for the voltage of your location.

Now plug the game into a grounded 3-wire outlet.

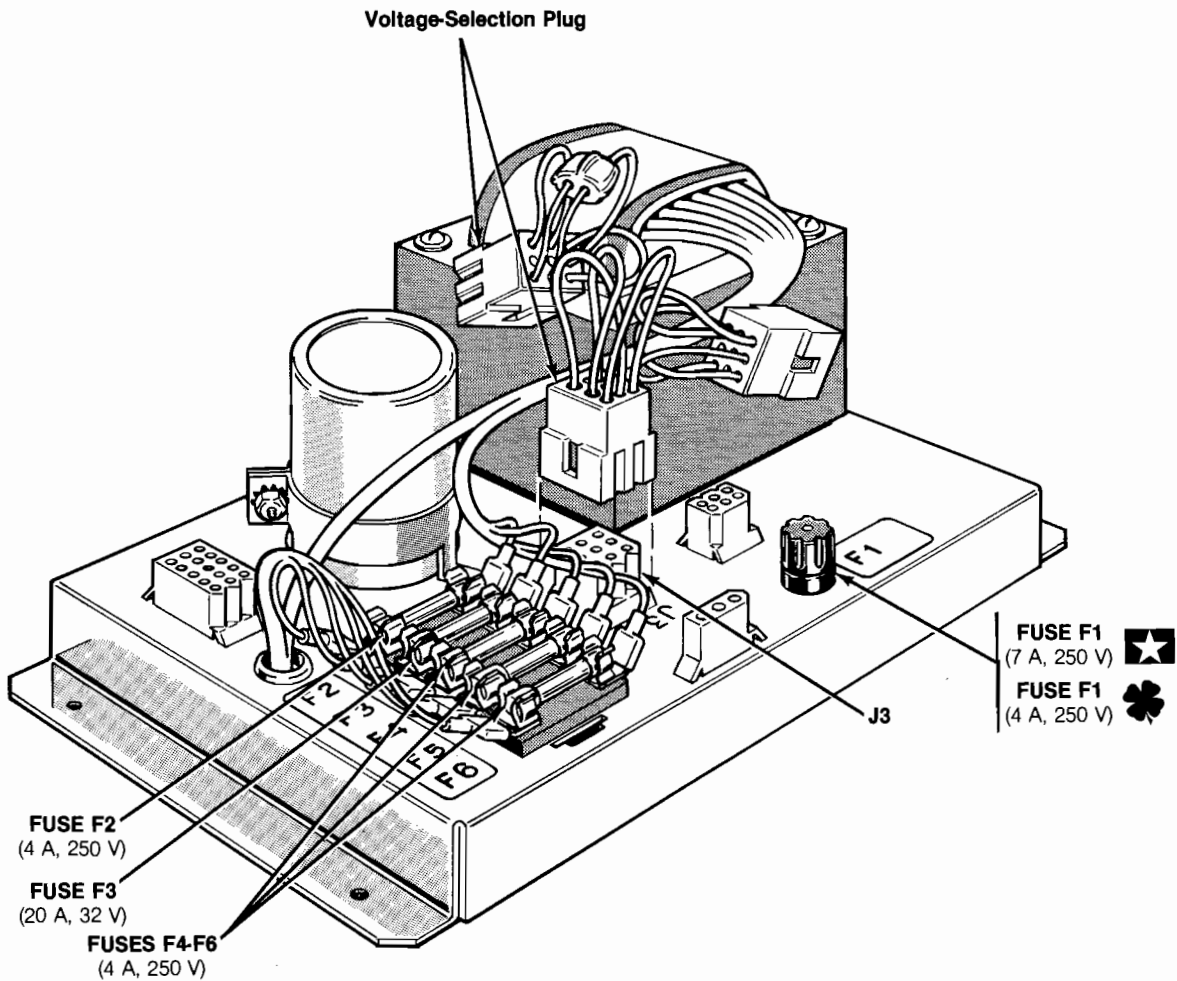


Figure 1-3 Voltage-Selection Plug and Fuses

F. Switch Locations

Power On/Off Switch

The power on/off switch is located on the back of the cabinet on the lower left side (see Figure 1-1 or 1-2).

Utility Panel Switches

The volume control, coin counter(s), self-test switch, and auxiliary coin switch are on the utility panel. The utility panel is located inside the upper coin door (see Figure 1-1 or 1-2). The volume control adjusts the level of sound produced by the game. The coin counter(s) records the number of coins entered into the game. The self-test switch initiates the self-test operating mode. The auxiliary coin switch is used to credit the game without activating a coin counter.

Option Switches

Option switches for game price selection are on the game printed-circuit board (PCB) at location SW1 (see Figure 1-4).

G. Selecting the Coin and Credit Options

Settings of the game coin and credit option switches are explained in Table 1-2. Options preset at the factory are shown by the ◀ symbols. However, you may change the settings according to your individual needs.

To verify other option selections, check the self-test display that appears when you turn on the game. Then, verify the option switch settings on the self-test display as described in Chapter 2, Checking Option Settings.

Table 1-2 describes the settings for the DIP switch at location SW1. This switch selects the game coin and credit options available for the left and right coin mechanisms.

The basic unit of measurement is a coin worth \$.25 or 1 DM. Thus, if you have a 2 DM/1 DM coin door with two coin counters, set switch 5 at location SW1 to on. Then, different denominations are counted on the two coin counters.

NOTE

Coin Option Interconnect Assembly J55A-P55A (A039655-01) permits a coin placed in either coin mechanism to register in the same coin counter. The cable connector is located between the coin door harness and the main harness (see the Coin Option Interconnect Wiring Diagram in SP-229). When it is used, left coin mechanism option switches at SW1 apply to both coin mechanisms.

If you want different options for the left and right coin mechanisms, remove Coin Option Interconnect Assembly J55A-P55A and connect J55 directly to P55.

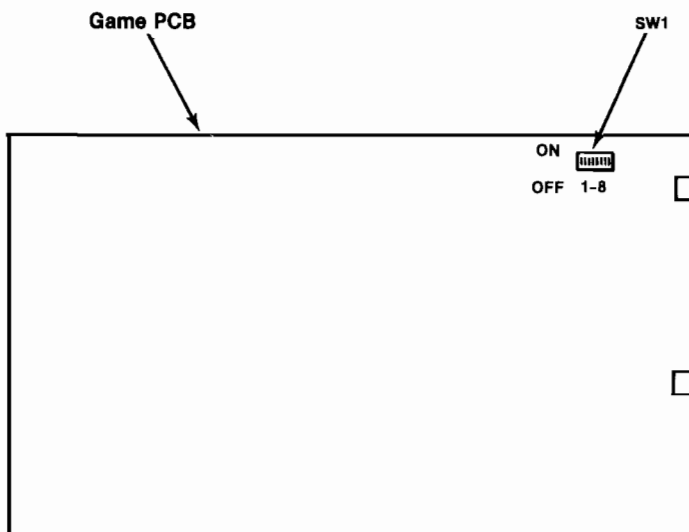
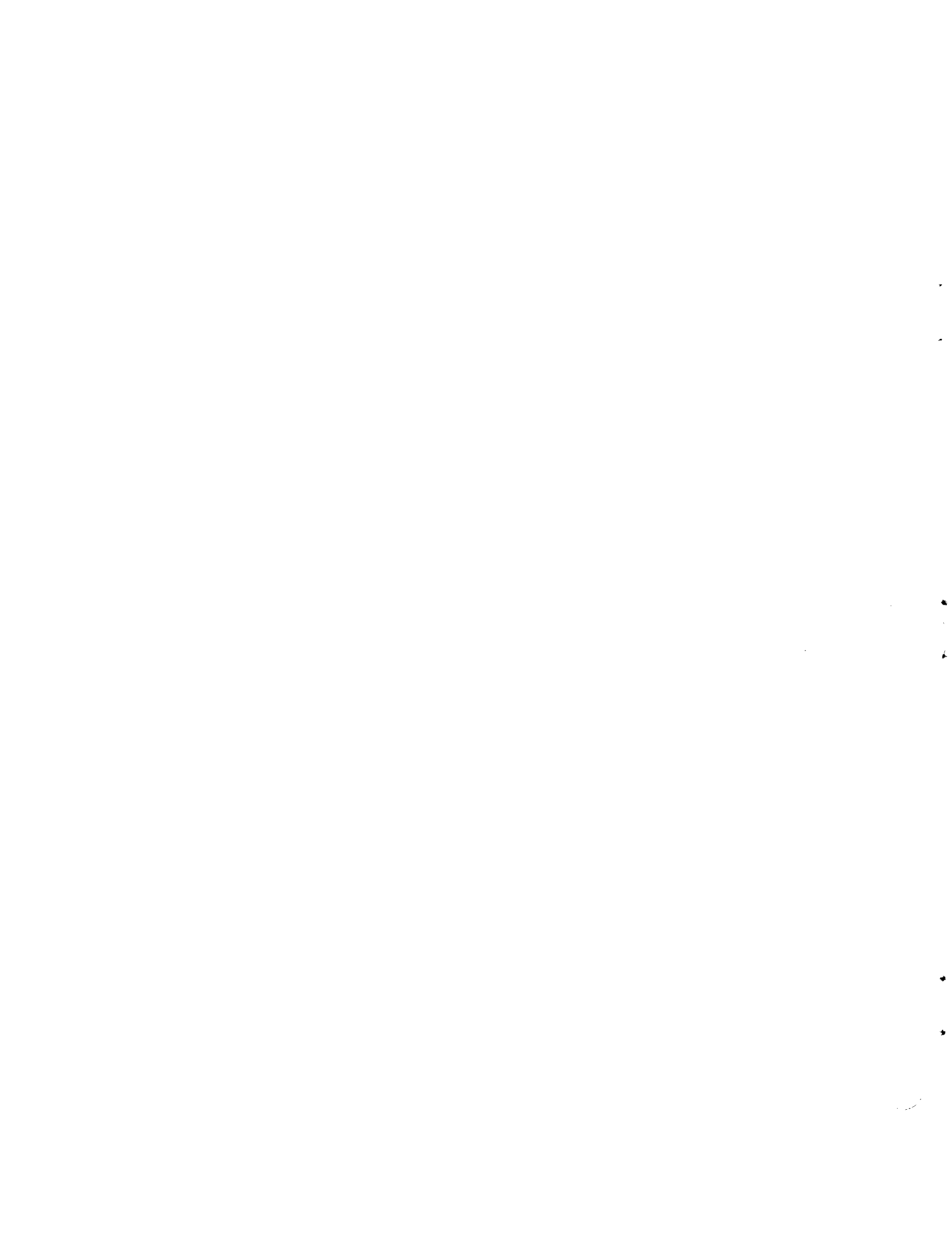


Figure 1-4 Option Switch Location

Table 1-2 Switch Settings for Coin and Credit Options

Settings of 8-Toggle Switch on Game PCB (at SW1)								Option
1	2	3	4	5	6	7	8	
Off	On							Free Play
On	On							1 coin 2 credits
Off	Off							1 coin 1 credit ◀
On	Off							2 coins 1 credit
								Right Coin Mechanism
		Off	Off					1 coin 1 credit ◀
		On	Off					1 coin 4 credits
		Off	On					1 coin 5 credits
		On	On					1 coin 6 credits
								Left Coin Mechanism
				Off				1 coin 1 credit ◀
				On				1 coin 2 credits
					Off	Off	Off	No bonus coins ◀
					On	Off	Off	No bonus coins
					Off	On	Off	For every 4 coins, logic adds 1 more coin
					On	On	Off	For every 2 coins, logic adds 1 more coin
					Off	Off	On	For every 5 coins, logic adds 1 more coin
					On	Off	On	For every 3 coins, logic adds 1 more coin
					Off	On	On	No bonus coins
					On	On	On	No bonus coins

◀ *Manufacturer's recommended settings*



Self-Test Procedure

This game will test itself and provide data to show that the game circuitry and controls are operating properly. Self-test data is presented visually on the player LEDs and the video display, and audibly through the speakers. No additional equipment is required.

We suggest that you perform a self-test when you first set up, each time you collect money, change the game options, or suspect game failure.



A. Self-Test Display

When the power switch is turned on, Food Fight enters the automatic selftest mode, which tests playfield RAM, program ROM, and non-volatile RAM (NVRAM). At the beginning of these tests, both the one-player and two-player LEDs are lit. (This is so that the success or failure of the tests can be indicated even if the messages cannot be displayed on the monitor.)

If the playfield RAM and program RAM are working, then the one-player LED turns off and the message RAM OK is displayed on the screen.

If the playfield RAM fails, the one-player LED flashes one through four times followed by a pause. The playfield RAM number displayed corresponds to the board location of the faulty chip as shown in Table 2-1.

Table 2-1 Playfield RAM Locations

Playfield RAM Number	Board Location
1	3K
2	3L
3	3M
4	3N

If the program RAM fails, the one-player LED remains on, and the number of the bad chip is displayed. The program RAM number corresponds to the board location of the faulty chip as shown in Table 2-2.

Table 2-2 Program RAM Locations

Program RAM Number	Board Location
0	8B
1	8A
2	9B
3	9A

After the RAM is checked, the checksums for program ROM are verified. If all ROMs check out correctly, then the two-player LED is turned off and the message ROM OK is displayed. If there are faulty chips, then the ROM number

of each faulty chip is displayed. The ROM number corresponds to the board location of the faulty chip as shown in Table 2-3.

Table 2-3 Program ROM Locations

ROM Number	Board Location
0	9C
1	8C
2	9D
3	8D
4	9E
5	8E
6	9F
7	8F

After the program ROM is checked, the checksums for the NVRAM are verified. If all sections of the NVRAM check, then the message NVRAM OK is displayed. If any section of NVRAM fails, then the name of the faulty section is displayed and factory values from program ROM are used instead of the values from that section.

If playfield RAM, program RAM, and NVRAM check out correctly, Food Fight goes into the attract mode after five seconds. If NVRAM fails, the game will go into the attract mode when the THROW button has been pushed.

The five sections of NVRAM are as follows:

STATISTICS holds the values for the statistics display (see the description under Self-Test Menu). These values can be reset using the options menu.

TIME AND CREDITS holds the total time the machine has been on, and the total number of credits. These appear at the bottom of the statistics display and cannot be reset.

HIGH SCORES holds the player initials, scores, and levels achieved for the top three high-scoring games. These values appear at the top of the high-score table during the attract mode and can be reset using the options menu.

OPTIONS holds the current settings for the game options, which can be displayed and/or changed using the options menu.

JOYSTICK VALUES holds the maximum and minimum values for the analog joystick. See the description of Joystick Calibration under the TESTS option of the self-test menu.



B. Self-Test Menu

Food Fight has a menu-driven self-test mode which is entered by turning the self-test switch on. Turning the self-test switch off at any time during self-test mode causes the game to return to the attract mode.

Immediately after the self-test switch is turned on, the main self-test menu appears as shown in Figure 2-1. Three choices are available—TESTS, STATISTICS, and OPTIONS. Move the joystick up or down to change the current selection, which is displayed in red. Push the THROW button to select.

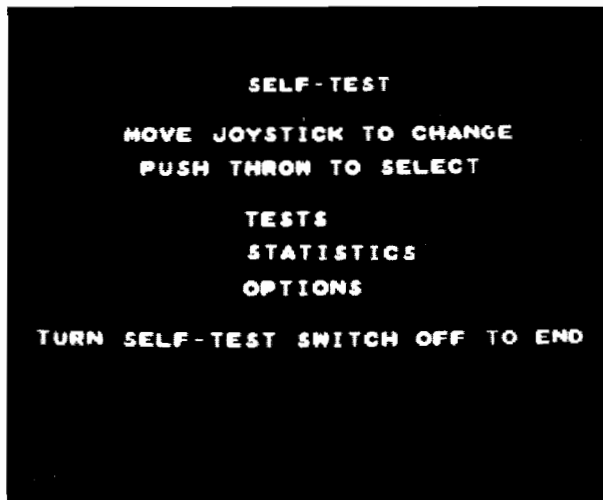


Figure 2-1 Main Self-Test Menu

NOTE

The two-player start button can be used to cycle through the selections in any of the self-test menus so the game can be tested even if the joystick is faulty.

Hardware Tests

Selecting TESTS causes the hardware test menu to appear as shown in Figure 2-2. There are five choices available—JOYSTICK CALIBRATION, SWITCH TEST, COLOR PATTERN, CONVERGENCE PATTERN, and SOUND TEST. Use the joystick and THROW button to select any option. Push the one-player start button to return to the main self-test menu.

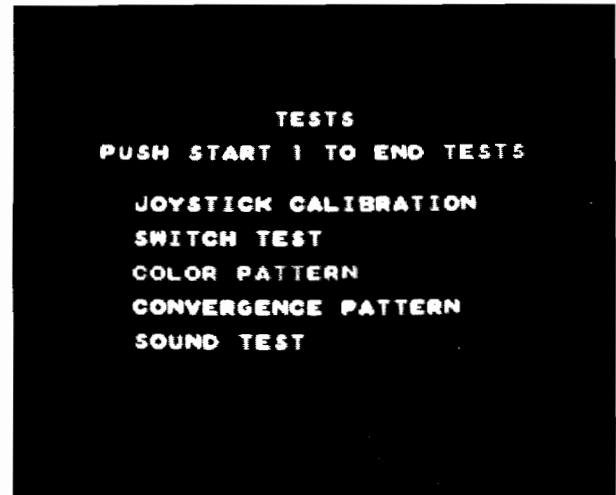
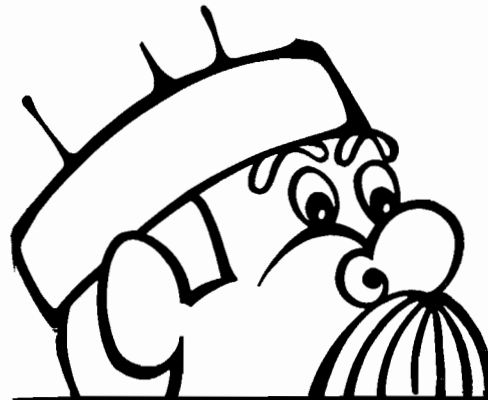


Figure 2-2 Hardware Tests Menu

JOYSTICK CALIBRATION resets the joystick minimum and maximum values, and should be used whenever the NVRAM or joystick is replaced. Hold the joystick steady for a full five seconds in each direction (left, right, up, down) to store new values. Push the one-player start button to return to the TESTS menu.

NOTE

Food Fight is equipped with a self-calibrating joystick, which checks its maximum and minimum values while the game is being played. Initial values are set at the factory and stored in NVRAM. When Food Fight is turned off, the NVRAM values are updated. Each time Food Fight is turned on, the current values are read out of NVRAM. If NVRAM fails (see the description under Automatic Self-Test), then the joystick is recalibrated as the game is being played. In this case, the control will be sluggish for the first game or two after the game is turned on.



SWITCH TEST displays the state of the control panel switches, the joystick values, the coin inputs, and the dual-inline-package (DIP) switches as shown in Figure 2-3. A one (1) indicates that the switch is on, and a zero (0) indicates it is off. All eight bits are displayed for each direction of the joystick. Push both the one- and two-player start buttons to end this test.

See Chapter 1, Selecting the Options, for information on the settings of the DIP switch located on the game PCB.



Figure 2-3 Switch Test Display

COLOR PATTERN displays all 256 Food Fight colors on a 16-by-16 grid of blocks in the center of the screen as shown in Figure 2-4. Use this display to check for color adjustment. Press the one-player start button to end this test. The colors are properly adjusted when the background is black and each colored block is distinguishable from those around it.

Food Fight has four blue levels, eight green levels, and eight red levels. These are overlaid to display the color grid as follows:

- Blue is displayed in four quadrants with level 0 (no blue) in the lower left quadrant, level 1 in the lower right quadrant, level 2 in the upper left quadrant, and level 3 (intense blue) in the upper right quadrant.
- Green is displayed in sixteen horizontal bars, two bars for each level, with level 0 (no green) bars at the center, level 7 (intense green) bars across the top and bottom, and intermediate levels in between.
- Red is displayed in sixteen vertical bars, with level 0 (no red) bars at the center, level 7 (intense red) bars at the right and left, and intermediate levels in between.

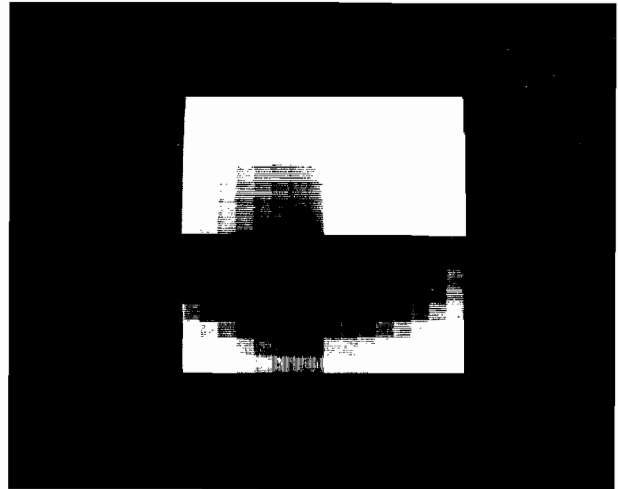


Figure 2-4 Color Pattern

CONVERGENCE PATTERN a white crosshatch pattern appears on the screen as shown in Figure 2-5. Use this pattern for convergence (see the raster-scan video display manual for a detailed procedure). Push the one-player start button to end this test.

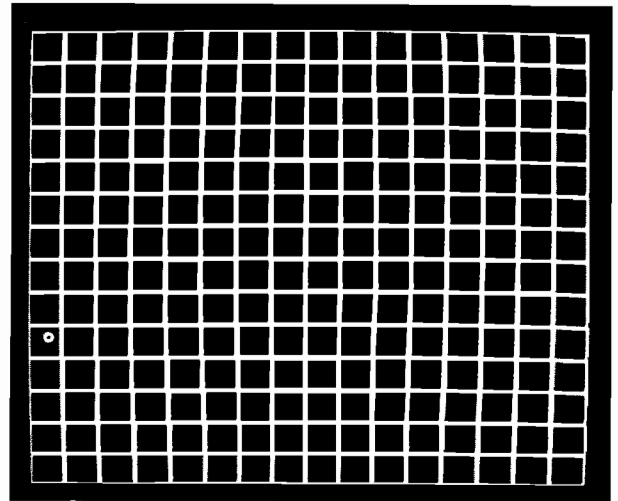


Figure 2-5 Convergence Pattern

SOUND TEST tests the twelve channels of the three Custom Audio sound chips. As the channel number is displayed, the test sound is played. The test continues to cycle through the channels until the one-player start button is pressed to end the test. The channels correspond to the three Custom Audio chips as shown in Table 2-4.

Table 2-4 Sound Chip Locations

Chip No.	Board Location	Channels
1	11K/L	5, 6, 11, 12
2	11L/M	1, 2, 7, 8
3	11N	3, 4, 9, 10

Selecting the Statistics

This is the second selection on the main self-test menu. Selecting STATISTICS causes the game statistics display to appear as shown in Figure 2-6. Press the one-player start button to end this test.

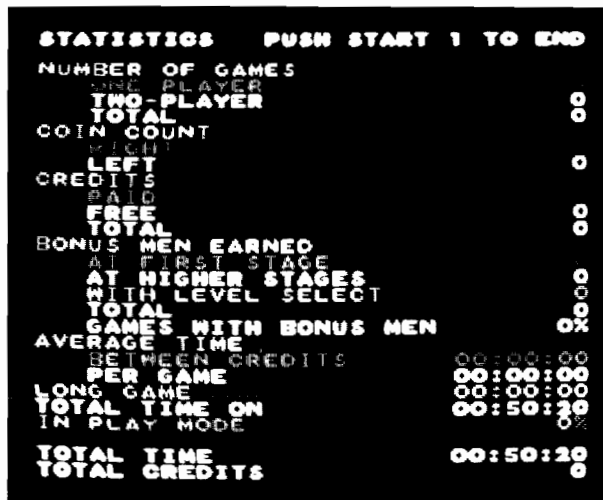


Figure 2-6 Statistics Display

The totals on the display are those accumulated since the statistics were last reset. All statistics (except the last two) can be reset using the CLEAR VALUES, and STATISTICS selections of the options menu. All times on the display are shown as hours:minutes:seconds. The following statistics are displayed:

NUMBER OF GAMES reads the number of one-player games, the number of two-player games (increased by one for each two-player game), and the total number of games.

COIN COUNT reads the number of coins inserted through each of the right and left coin mechanisms.

CREDITS reads the number of paid credits, free credits (entered using the auxiliary coin button), and the total credits since the statistics were last reset.

BONUS MEN EARNED reads the number of bonus lives (extra Chucks) earned at the first stage at higher stages using level select, and the total. It also shows the percentage of games played in which at least one bonus life was earned.

AVERAGE TIME reads the average times between credits and games.

LONG GAME reads the longest time a player was able to play on one credit.

TOTAL TIME ON reads the total time the game has been turned on since the statistics were last reset.

IN PLAY MODE reads the percentage of time the game has been in play mode (as opposed to attract mode) since the statistics were last reset.

NOTE
The last two statistics cannot be reset. They are accumulated from the date the game was manufactured, or since the NVRAM last failed or was replaced.

TOTAL TIME reads the total amount of time the game has been turned on.

TOTAL CREDITS reads the total number of credits.

C. Selecting the Options

Selecting OPTIONS, the third selection on the main self-test menu, causes the options display shown in Figure 2-7 to appear. Use this display to view or change game option settings, or to clear the high scores or statistics. Push the THROW button to cycle through values on the current row (indicated in red). Change the current row using the joystick or the two-player start button. Push the one-player start button to end this display and make the displayed option settings the current settings.

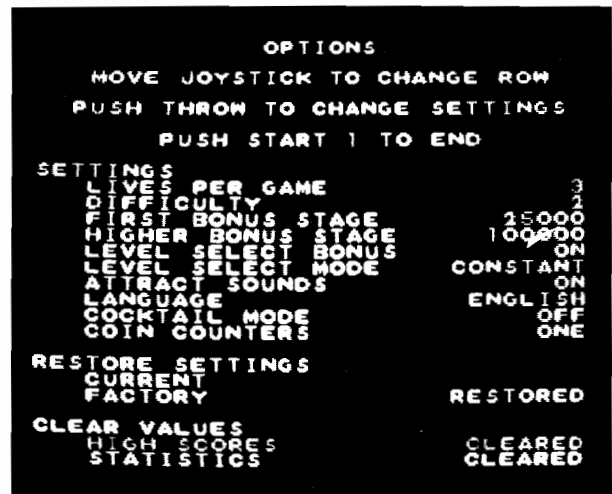


Figure 2-7 Options Display

To restore settings or to clear values, select the desired row and push the THROW button. RESTORED or CLEARED is then displayed. The options and settings available are listed in Table 2-5.

NOTE

Turning off the self-test switch during this display will cause the current option settings, the high scores, and statistics to be unaffected.

Description of Option Terms

LIVES PER GAME sets the initial number of lives (Chucks), not including bonus lives, given for each credit.

DIFFICULTY sets the game difficulty at levels 4 and above. Level 1 is easy, level 5 is hard.

BONUS STAGES. sets the scores at which the first or subsequent bonus lives are awarded. Additional bonus lives are awarded when the score reaches a multiple of the higher bonus stage. For example, when the factory settings of 25,000 and 100,000 are in effect, bonus lives are awarded at 25,000; 100,000; 200,000; 300,000; etc.

The first bonus stage may not exceed the second bonus stage. If the two are equal, only one bonus life is awarded when the score reaches the first bonus stage. For example, if both stages are set to 25,000, then bonus lives are awarded at 25,000; 50,000; 75,000; etc. Either one or both bonus stages can be turned off.

LEVEL SELECT BONUS if turned on, awards bonus lives when the player uses level select to start the game at or above level 10. An extra life is awarded for starting at

levels at or above every multiple of 10, with one additional life at level 125. For example, ten bonus lives would be awarded for starting at level 103. These bonus lives are given at the start of the game in addition to the LIVES PER GAME. The level at which bonus lives are earned and the current number of lives awarded are displayed with Chuck heads during level select.

LEVEL SELECT MODE effects how the level select feature is handled. There are four possible settings:

- **NORMAL** allows the player to select a starting level if the last game ended less than 15 seconds before, and if the maximum level achieved in the last game was greater than level one. If both of these cases hold, the player is allowed to select a starting level up to the maximum level achieved in the last game.
- **CONSTANT** always allows the player to select a starting level up to at least level 9. If the last game ended less than 15 seconds before, the player is allowed to select up to the maximum level achieved in the last game.
- **DEMO** always allows the player to select up to the maximum Food Fight level, for example, level 125. This setting would probably not be used for a game out on location, but is useful to demonstrate the performance of the game at high levels.
- **OFF** causes no level select display to occur.

ATTRACT SOUNDS disables the attract mode sounds if in the OFF setting.

COIN COUNTERS causes both coin mechanisms to drive the same coin counter if in the ONE setting.

Table 2-5 Option Settings

Option	Settings Available	Factory Setting
Lives per game	2-5	3
Difficulty	1-5	2
First bonus stage	Off, 5000-1,000,000	25,000
Higher bonus stage	Off, 5000-1,000,000	100,000
Level select bonus	Off/On	On
Level select mode	Normal, constant, demo, off	Constant
Attract sounds	Off/On	On
Language	English, German, Spanish, French	English
Cocktail mode	Off/On	Off
Coin counters	One/Two	One

RESTORE SETTINGS resets the displayed option settings to one of the following:

- **CURRENT** displays the option settings in effect before the option menu was entered.
- **FACTORY** displays the option settings from the program ROM.

NOTE

Remember that the high scores and statistics will NOT be affected if the options menu is ended by turning off the self-test switch.

CLEAR VALUES resets the high-score table to its factory setting and resets to zero all the items on the statistics display, except for the **TOTAL TIME** and **TOTAL CREDITS**. The clear takes effect when the options menu is ended using the one-player start button.

Illustrated Parts Lists

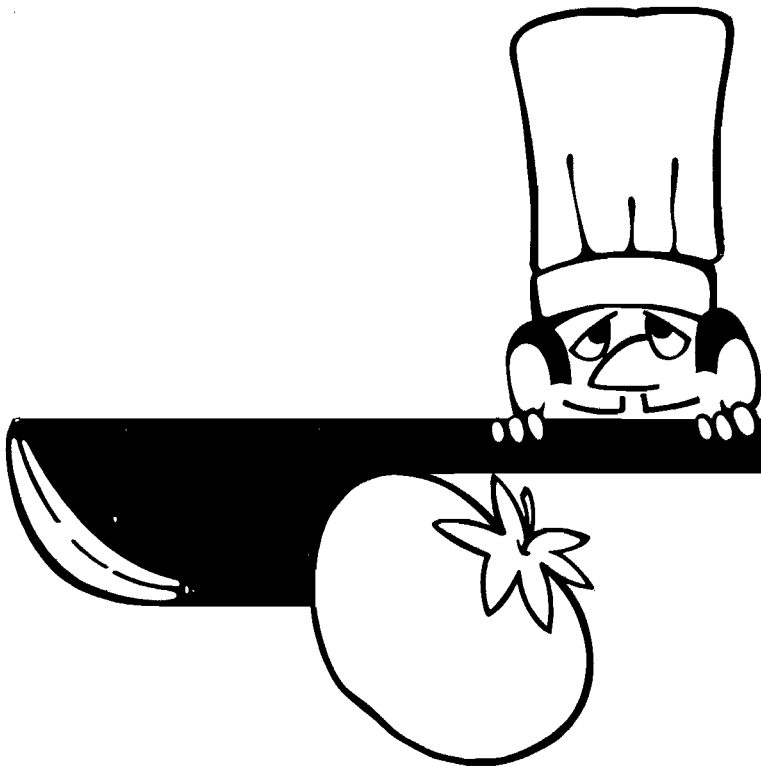
This chapter provides information you need to order parts for your game. Common hardware (screws, nuts, washers, etc.) has been deleted from most of the parts lists. However, there is a parts list for the hardware to mount the game PCB and Regulator/Audio II PCB to the cabinet.

The PCB parts lists are arranged in alphabetical order by component. Each component subsection is arranged alphanumerically by reference designator.

Other parts lists are arranged alphanumerically by Atari part number. In these parts lists, all A-prefix numbers come first. Following these are numbers in sequence evaluated up to the hyphen, namely 00- through 99-, then 000598- through approximately 201000-.

When ordering parts, please give the part number, part name, number of this manual, and serial number of your game. This will aid in filling your order rapidly and correctly. We hope the results will be less downtime and more profit from your game.

Atari Customer Service numbers are listed on the inside front cover of this manual.



Manuals, Schematics, & Self-Test Label—
 See parts list on following page

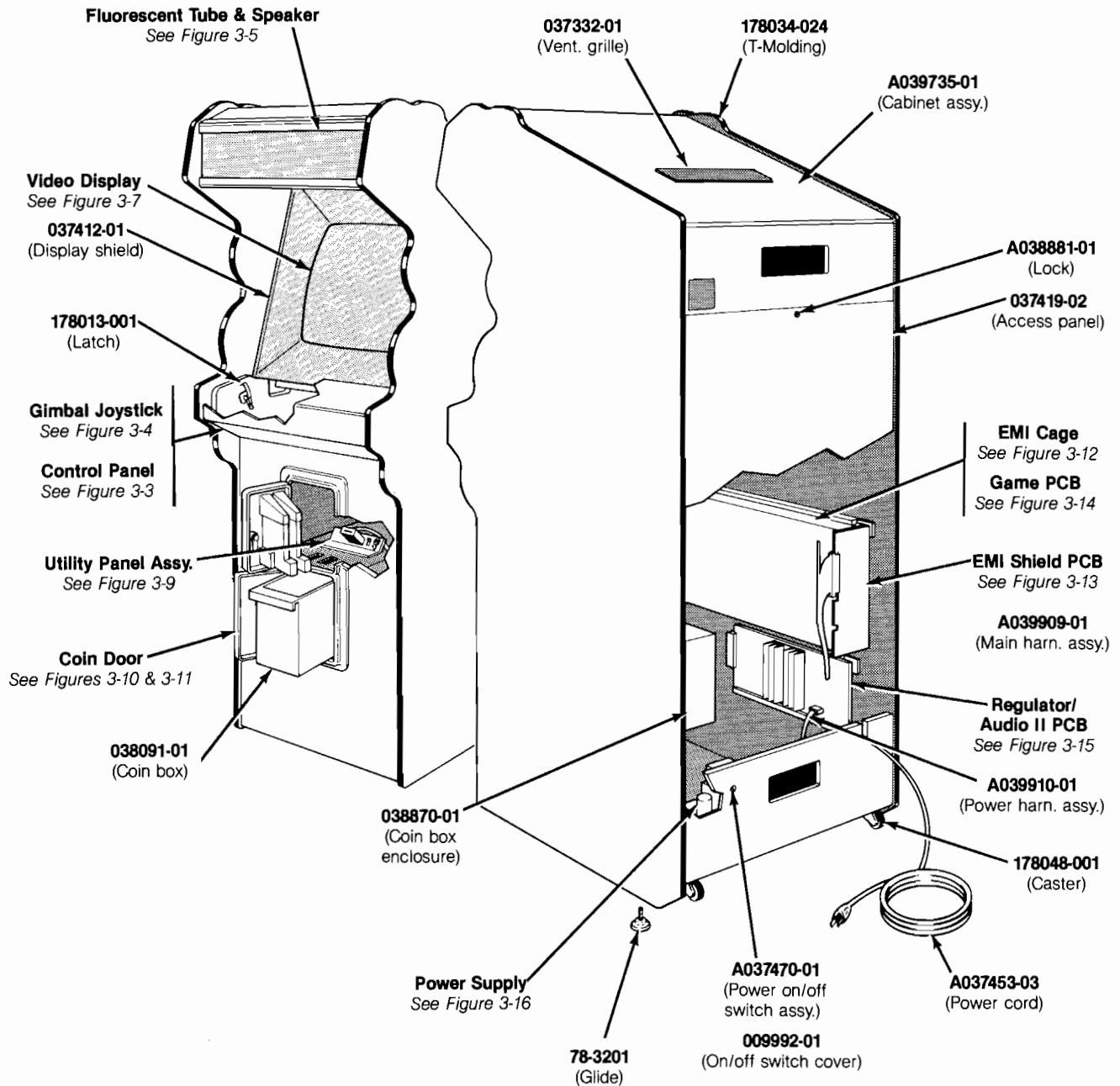


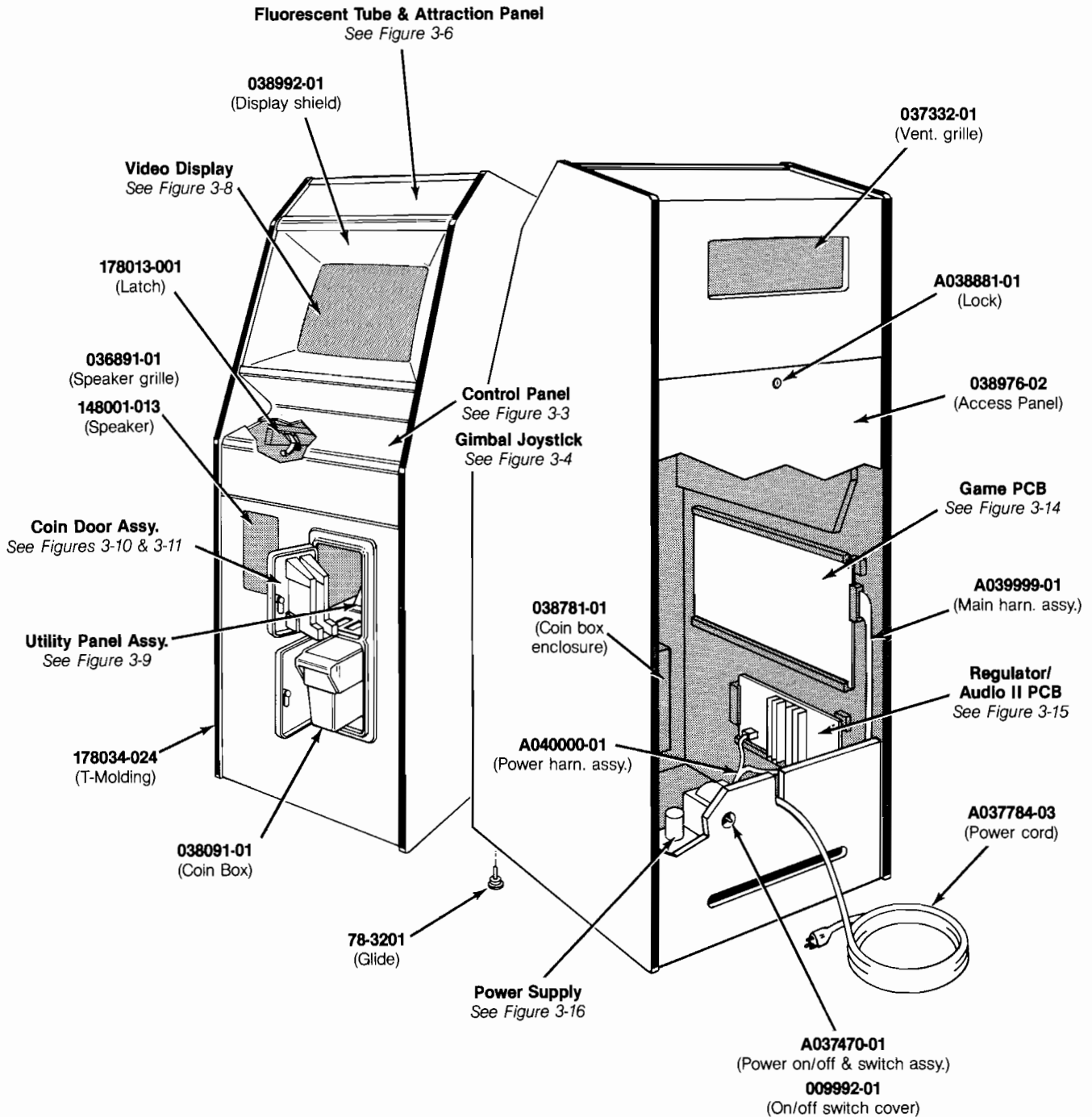
Figure 3-1 Cabinet-Mounted Assemblies
US-Built Game A039734-01 A

Cabinet-Mounted Assemblies Parts List

Part No.	Description
A037453-03	Strain-Relief Power Cord (U.S. and Canada)
A037470-01	Power On/Off Switch and Mounting Plate Assembly
A038881-01	Lock Assembly (for rear access panel) Acceptable substitute is part no. A038881-03
A039735-01	Cabinet Assembly (includes glides and PCB retainers, but not the rear access panel)
A039909-01	Main Harness Assembly
A039910-01	Power Harness Assembly
<i>The following four items are technical information supplements to this game:</i>	
SP-229	Food Fight Schematic Package
ST-229-01	Food Fight Label with Self-Test Procedure and Option Switch Settings
TM-160	Service Manual for 19-Inch Electrohome Color Raster Display (use with part no. 92-049) Acceptable substitute is TM- 220, for use with part no. 139003-1004
TM-229	Food Fight Operators Manual with Illustrated Parts List
78-3201	Adjustable Glide
009992-01	Power On/Off Switch Cover
036495-01	Speaker Grille (not shown)
037332-01	Ventilation Grille
037419-02	Rear Access Panel (does not include lock)
038091-01	Molded Coin Box
038870-01	Coin Box Enclosure
039752-01	Video Display Shield
178013-001	Spring Draw Latch
178034-024	¾-Inch Black Plastic T-Molding
178048-001	2-Inch Rigid Caster

Manuals, Schematics, & Self-Test Label—

See parts list on following page



**Figure 3-2 Cabinet-Mounted Assemblies
Ireland-Built Game A040005-02 A**

Cabinet-Mounted Assemblies Parts List

Part No.	Description
A037470-01	Power On/Off Switch & Mounting Plate Assembly
A037784-03	Strain-Relief Power Cord (United Kingdom, Ireland, Lebanon, Saudi Arabia, India, Hong Kong, Singapore, Egypt, Nigeria, Republic of South African, Zimbabwe)
A038881-01	Lock Assembly (for rear access panel)
A039999-01	Main Harness Assembly
A040000-01	Power Harness Assembly
A040006-01	Cabinet Assembly (includes glides and PCB retainers, but not the rear access panel)
<i>The following five items are technical information supplements to this game:</i>	
SP-229	Food Fight Schematic Package
ST-229-01	Food Fight Label with Self-Test Procedure and Option Switch Settings
TM-160	Service Manual for 19-Inch Electrohome Color Raster Display (use with part no. 92-049) or
TM-201	Service Manual for 19-Inch Wells Gardner Color Raster Display (use with part no. 92-055)
TM-229	Food Fight Operators Manual with Illustrated Parts List
72-6810S	#8 x $\frac{5}{8}$ -Inch Cross-Recessed, Pan-Head Screw
78-3201	Adjustable Glide
009992-01	Power On/Off Switch Cover
034536-02	Foam Pad (not shown)
036891-01	Speaker Grille
037332-01	Ventilation Grille
038976-02	Rear Access Panel (does not include lock)
038091-01	Molded Coin Box
038781-01	Coin Box Enclosure
038992-01	Video Display Shield
148001-013	Speaker
175004-708	#8 Flat Fiber Washer
178013-001	Spring Draw Latch
178034-024	$\frac{3}{4}$ -Inch Black Plastic T-Molding

! WARNING !
 Players may receive an electrical shock if this control panel is not properly grounded! After servicing any parts on the panel, make sure that the ground wire is firmly attached to the metal tab on the inside of the control panel.

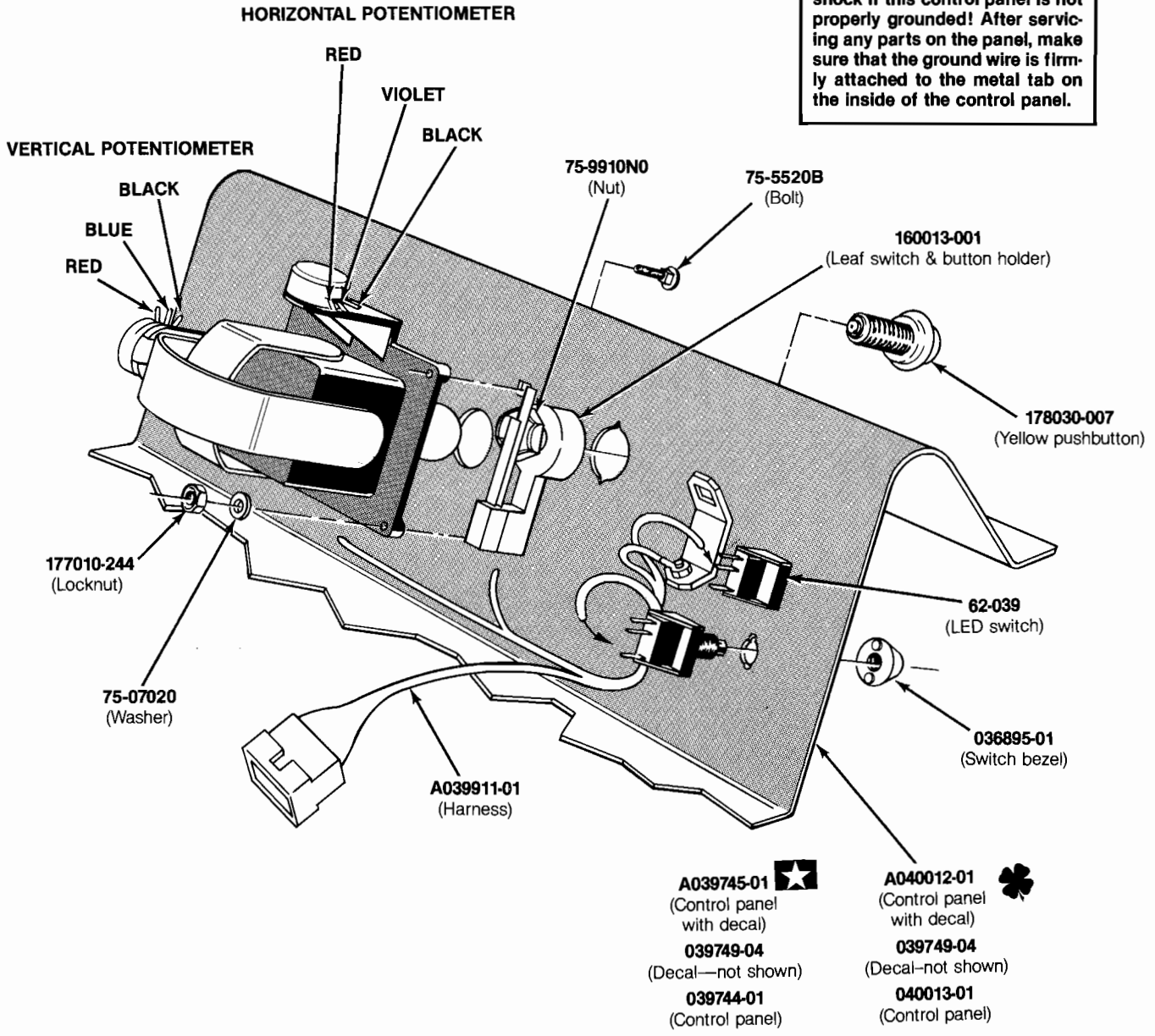
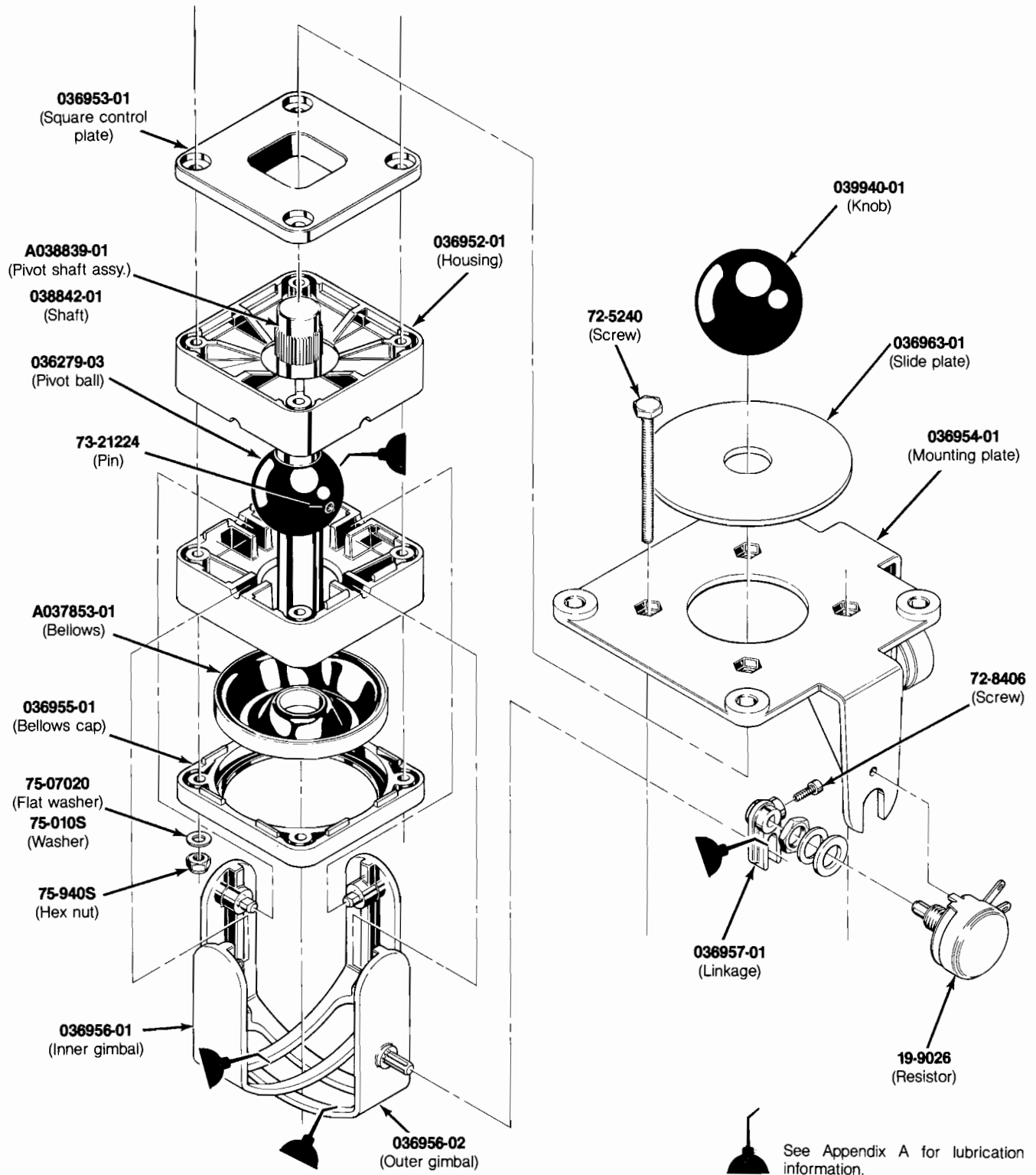


Figure 3-3 Control Panel Assembly
US-Built Game A039746-01 A
Ireland-Built Game A040011-01 A

Control Panel Assembly Parts List

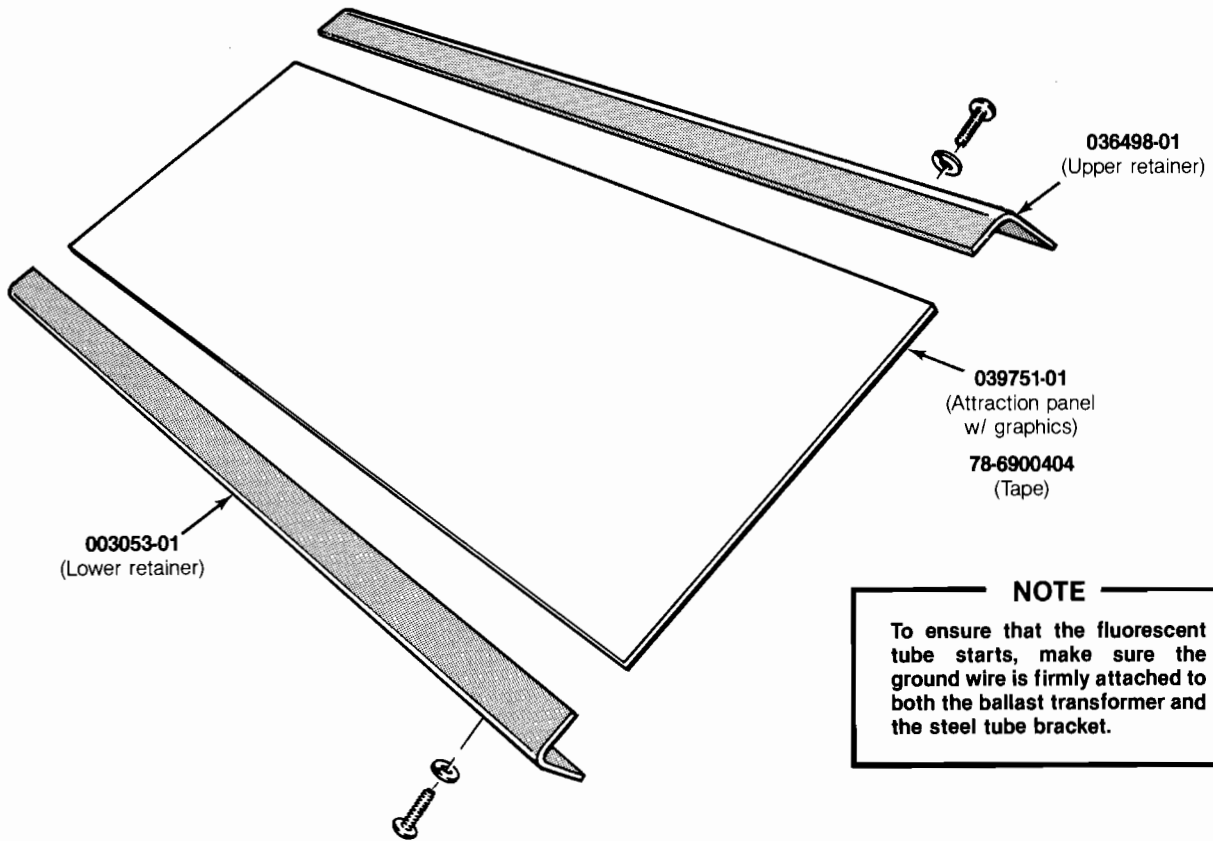
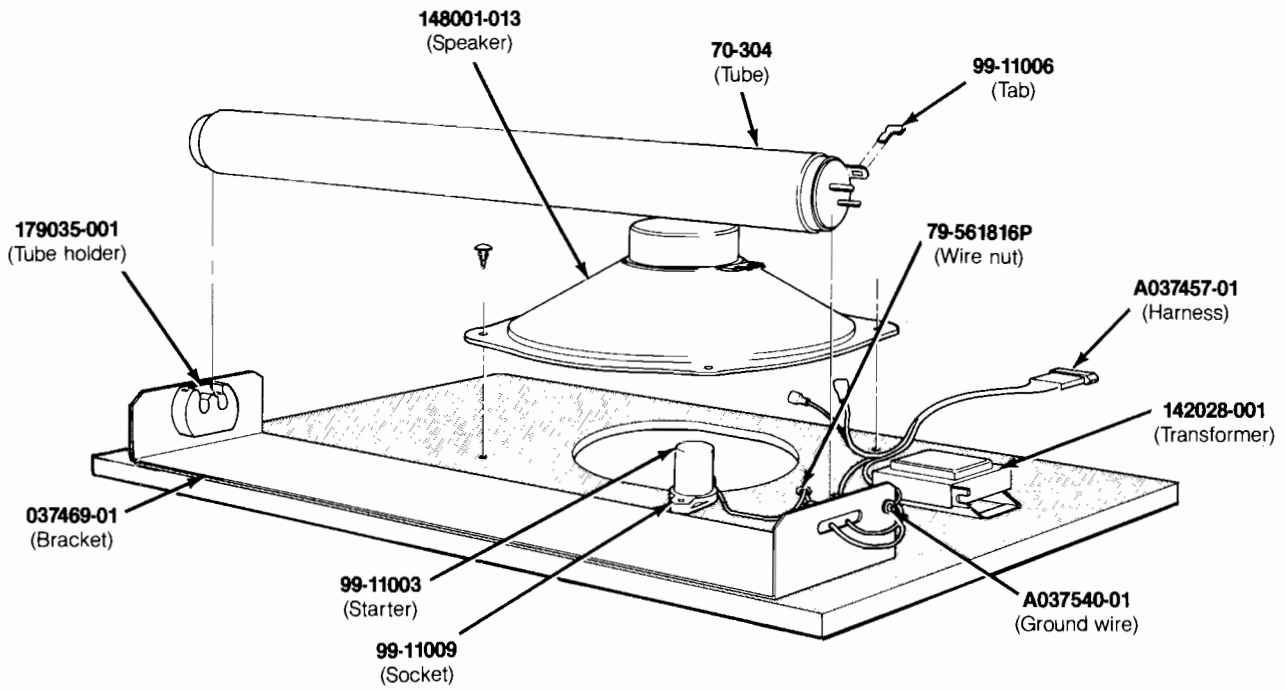
Part No.	Description
<i>US-Built</i>	
A039745-01	Control Panel with Decal
78-6900402	Vinyl Foam Single-Coated Adhesive Tape, ¼-Inch Wide x ⅛-Inch Thick (24 inches required)
039744-01	Control Panel
039749-04	Control Panel Decal (not shown)
<i>Ireland-Built</i>	
A040012-01	Control Panel with Decal
039749-04	Control Panel Decal (not shown)
040013-01	Control Panel
179125-001	Grounding Terminal (not shown)
<i>US- and Ireland-Built</i>	
A038838-02	Gimbal Joystick Assembly
A039911-01	Control Panel Harness Assembly
62-039	SPDT Momentary Pushbutton Start Switch with Red Light-Emitting Diode
75-07020	#¼ Steel Flat Washer
75-5520B	#¼-20 × 1¼-Inch Black Carriage Bolt
75-9910N0	#⅝ × 11 Stamped Nut
036895-01	Black Molded Switch Bezel
160013-001	Leaf Switch and Button Holder (leaf switch only is part no. 160012-001)
177010-244	#¼-20 Hex Locknut
178030-007	Yellow Pushbutton Assembly



**Figure 3-4 Gimbal Joystick Assembly
A038838-02 A**

Gimbal Joystick Assembly Parts List

Part No.	Description
A037853-01	Bellows Assembly
A038839-01	Pivot Shaft Assembly (includes pivot ball, pivot shaft and slotted pin)
19-9026	5 k Ω , \pm 20%, 2 1/4 W Variable Resistor (acceptable substitute is part no. 119000-502)
72-5240	#10-32 x 2 1/2-Inch, Zinc-Plated Steel Machine Screw
72-8406	#4-40 x 3/8-Inch Socket-Head Steel Machine Screw
73-21224	3/16-Inch Diameter x 1 1/2-Inch Long Slotted Pin
75-010S	#10 Flat Zinc-Plated Steel Washer
75-07020	3/8-Inch Interior Diameter Special Flat Washer
75-940S	#10-32 Self-Locking Hex Nut
036279-03	Pivot Ball
036952-01	Pivot Ball Housing (two required per handle)
036953-01	Square Control Plate
036954-01	Mounting Plate
036955-01	Bellows Cap
036956-01	Inner Gimbal
036956-02	Outer Gimbal
036957-01	Gimbal Linkage
036963-01	Slide Plate
038842-01	Pivot Shaft
039940-01	Pivot Ball Knob
178027-001	Nyogel 779 Lubricant

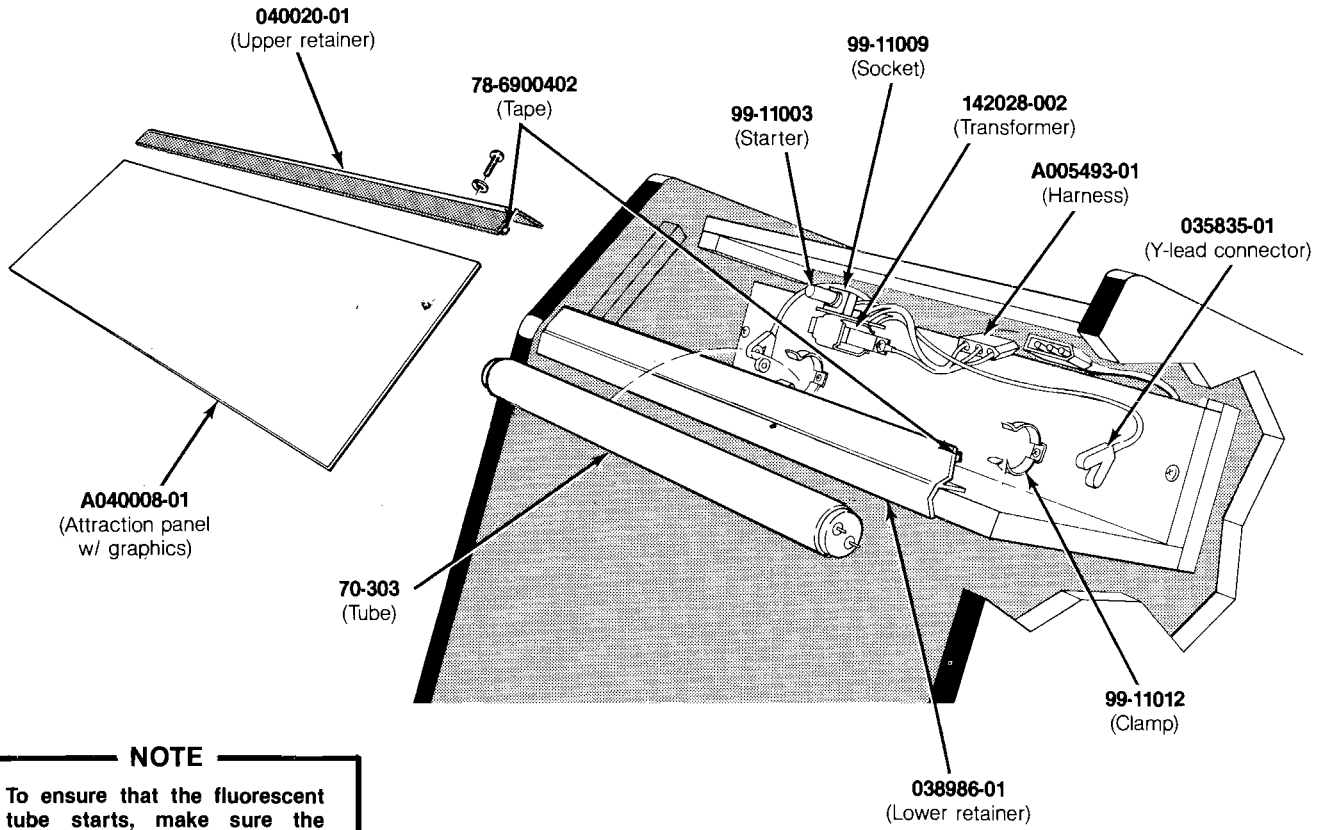


NOTE
To ensure that the fluorescent tube starts, make sure the ground wire is firmly attached to both the ballast transformer and the steel tube bracket.

**Figure 3-5 Fluorescent Tube and Speaker Assembly
A039737-01 A
US-Built Game**

Fluorescent Tube and Speaker Assembly Parts List

Part No.	Description
A037457-01	Tube and Speaker Harness Assembly
A037540-01	Ground Wire with Ring Lug
70-304	18-Inch, 15-Watt, Cool White Fluorescent Tube
78-6900404	Vinyl Foam Single-Coated Adhesive Tape, ¼-Inch Wide x ¼-Inch Thick (48 inches required)
79-561816P	Spring-Connector Wire Nut for 16- to 18-Gauge Wires
99-11003	Fluorescent Tube Starter
99-11006	Fluorescent Tube Locking Tab (consists of two pieces)
99-11009	Starter Socket
003053-01	Lower Attraction Panel Retainer
036498-01	Upper Attraction Panel Retainer
037469-01	Steel Tube Bracket
038151-01	15-Inch Jumper Wire
039751-01	Attraction Panel with Graphics
142028-001	60 Hz, 118-Volt, Ballast Trsformer (used on A038161-01 assembly)
148001-013	6 × 9-Inch Oval, 4 Ω, 6-Ounce, Shielded High-Fidelity Speaker
179035-01	2-Pin Fluorescent Tube Holder
179125-001	Grounding Clip (not shown)

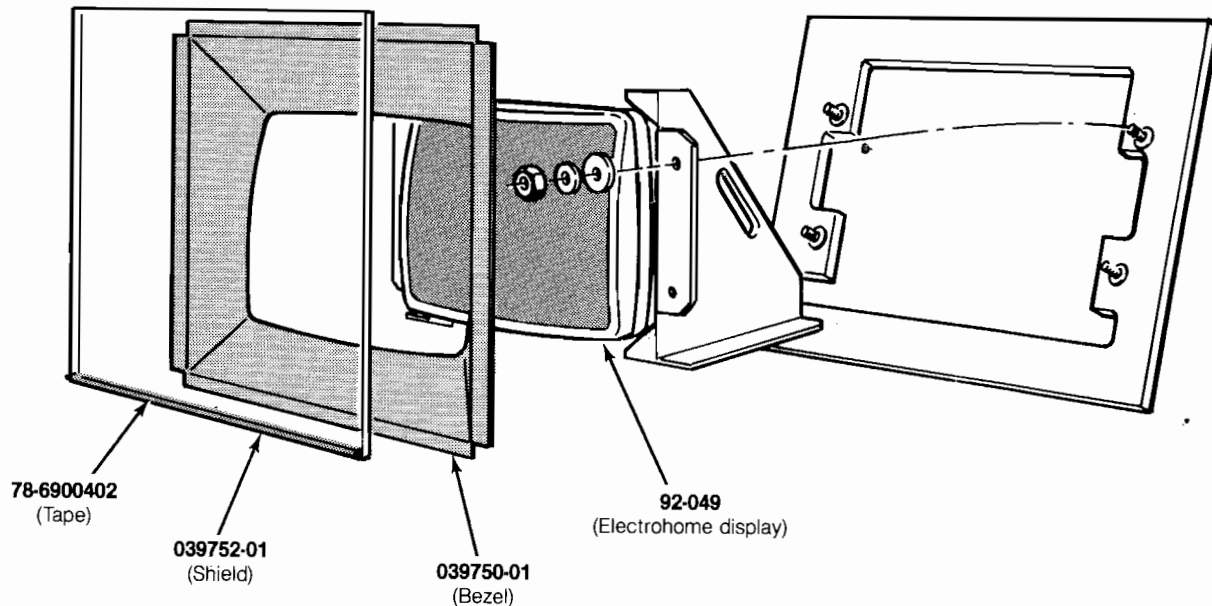


NOTE
 To ensure that the fluorescent tube starts, make sure the ground wire is firmly attached to the ballast transformer.

**Figure 3-6 Fluorescent Tube and Attraction Panel
 Ireland-Built Game**

Parts List

Part No.	Description
A005493-01	Fluorescent Tube Harness Assembly
A040008-01	Attraction Panel with Graphics
70-303	18-Inch, 15-Watt, Cool White Fluorescent Tube
78-6900402	Vinyl Foam Single-Coated Adhesive Tape, ¼-Inch Wide x ⅛-Inch Thick (not shown—48 inches required)
99-11003	Fluorescent Tube Starter
99-11009	Starter Socket
99-11012	1 ⅛-Inch Fluorescent Tube Clamp
035835-01	12-Inch Y-Lead Connector
038986-01	Lower Attraction Panel Retainer
040020-01	Upper Attraction Panel Retainer
142028-001	50 Hz, 118 V, Ballast Transformer



WARNING

Shock Hazard

The following procedure should only be performed by a qualified service technician. Before removing or repairing the video display, unplug the game.

High voltages may exist in any video display, even with power disconnected. Use extreme caution and do not touch electrical

parts of the display yoke area with your hands or with metal objects in your hands!

Discharge the high-voltage from the cathode ray tube as follows: Attach one end of a large, well-insulated, 20-kV jumper to ground. Momentarily touch the free end of the grounded jumper to the anode by sliding it under

the anode cap. Wait two minutes and discharge the anode again.

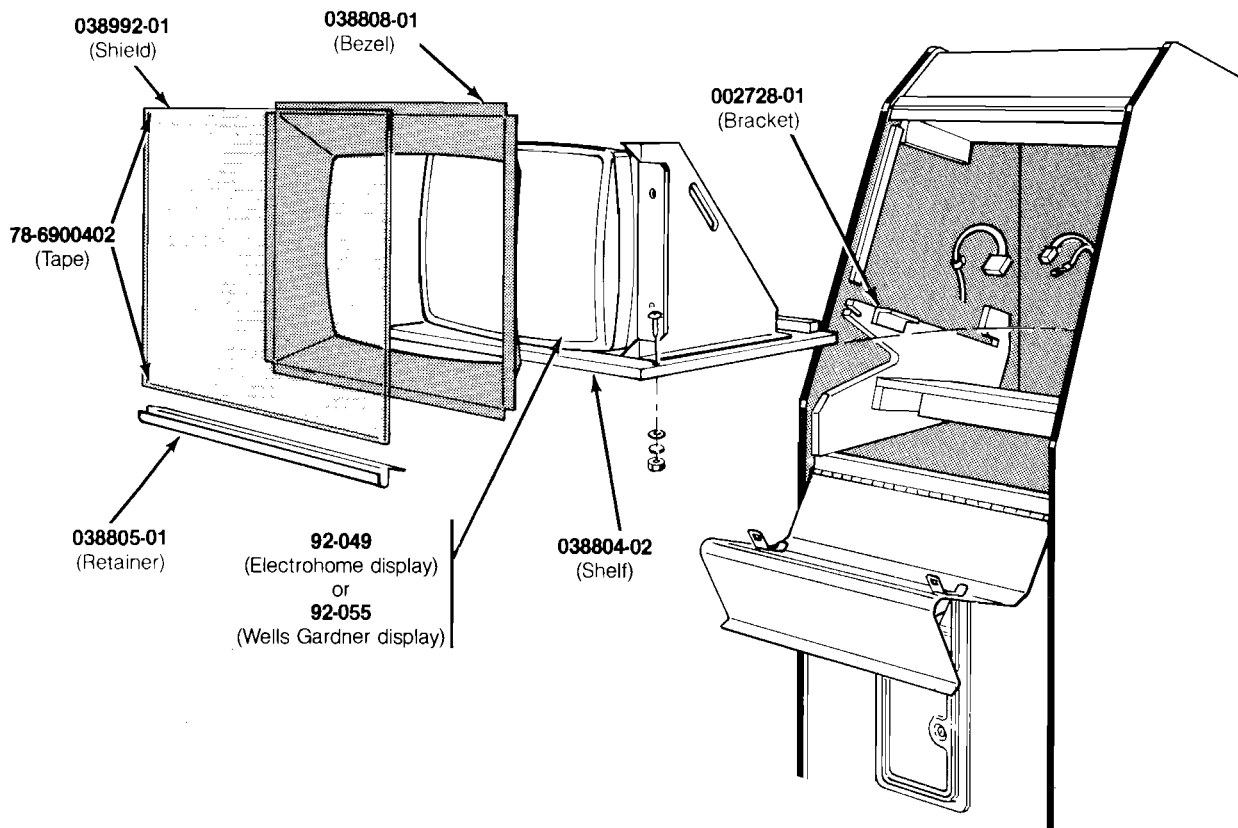
Implosion Hazard

If you drop the display and the picture tube breaks, it will implode! Shattered glass and the yoke can fly six feet or more from the implosion. Use care when replacing any display.

**Figure 3-7 Video Display
US-Built Game**

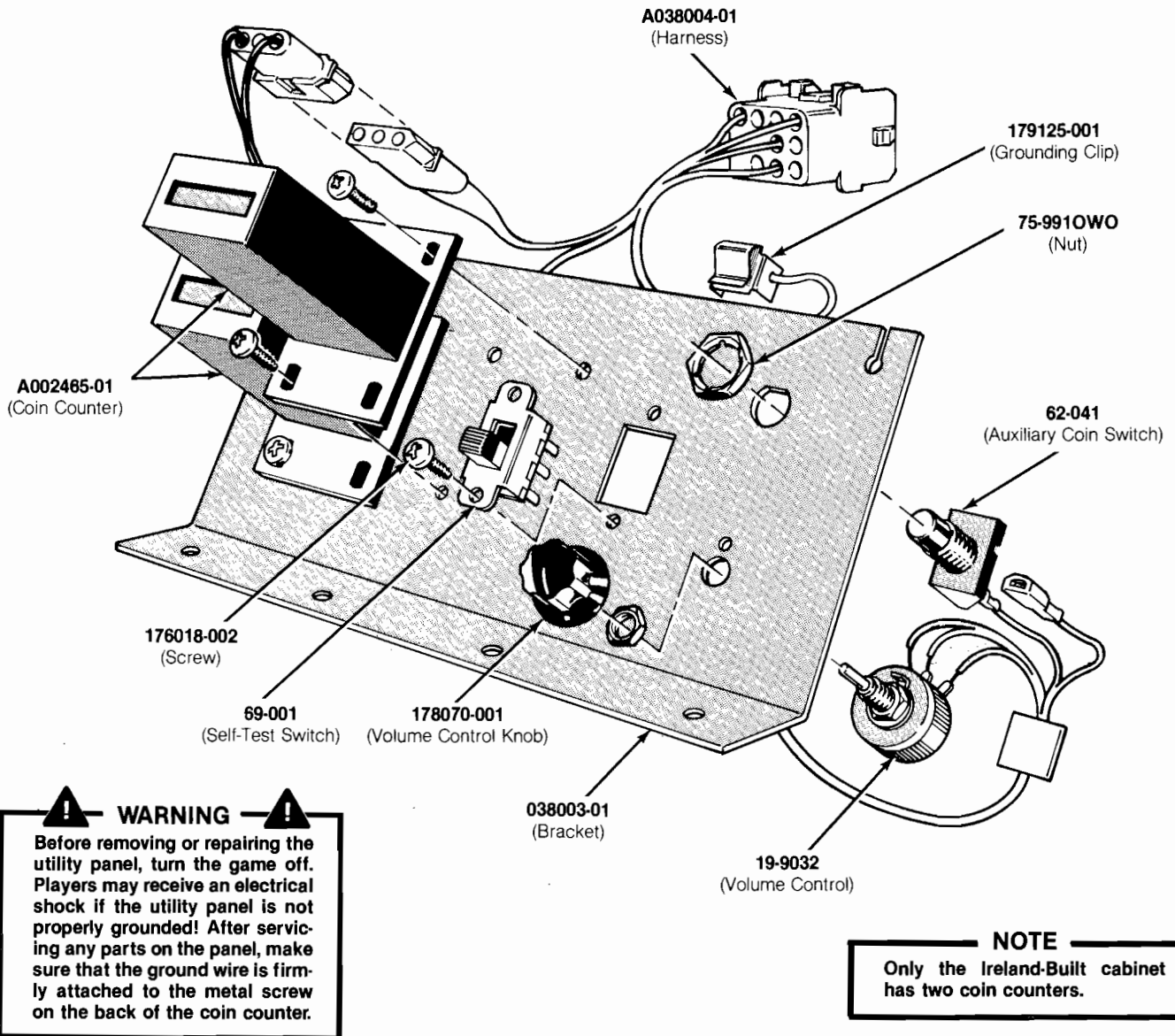
Parts List

Part No.	Description
78-6900402	Vinyl Foam Single-Coated Adhesive Tape, ¼-Inch Wide x ⅛-Inch Thick (24 inches required)
039750-01	Display Bezel
039752-01	Display Shield with Graphics
92-049	19-Inch Electrohome Color Raster-Scan Display (Acceptable substitute is part no. 139003-1004—19-Inch Matsushita Color Raster-Scan Display)



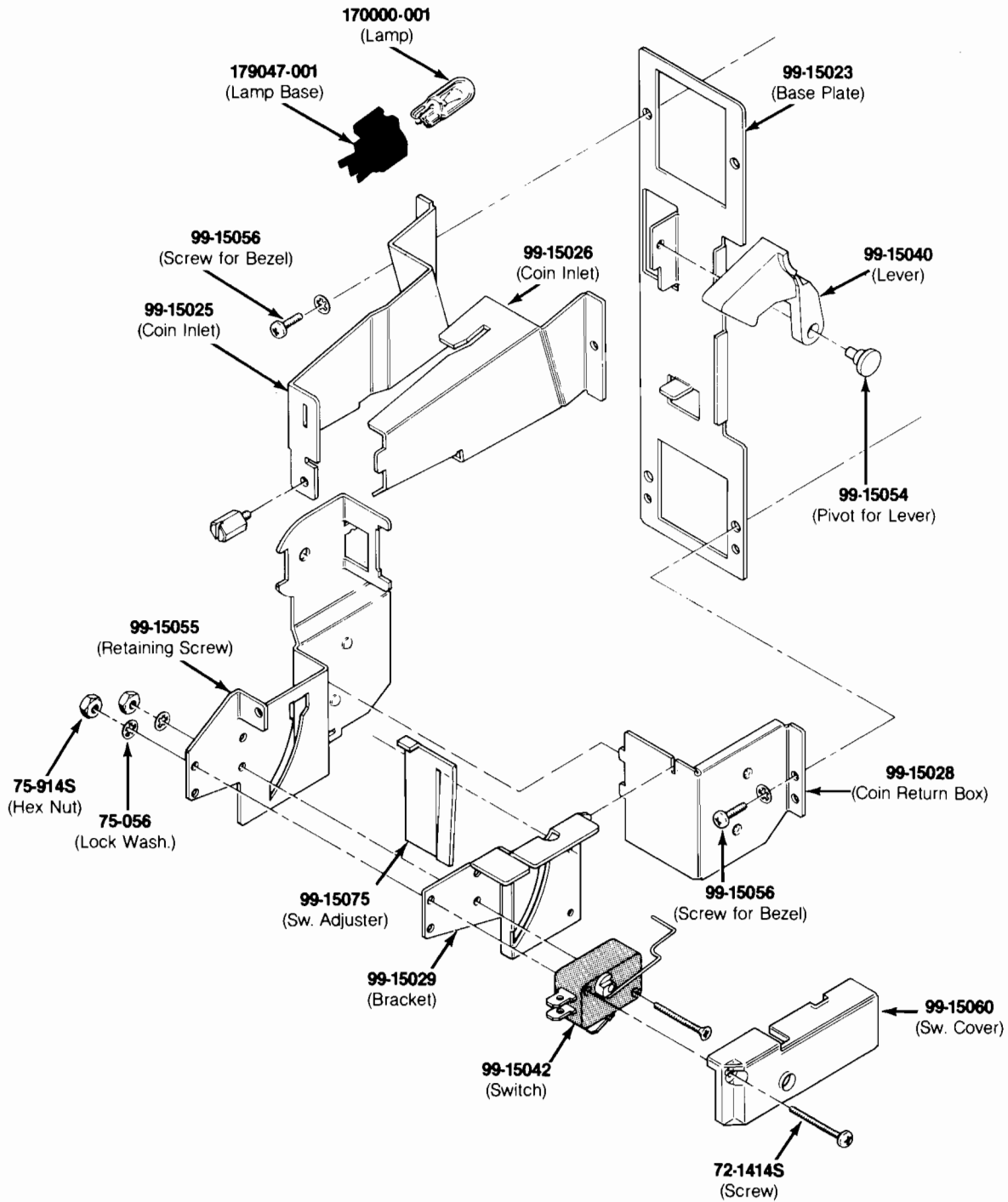
**Figure 3-8 Video Display
Ireland-Built Game
Parts List**

Part No.	Description
78-6900402 92-049 92-055 002728-01	Vinyl Foam Single-Coated Adhesive Tape, ¼-Inch Wide x ⅛-Inch Thick (48 inches required—not shown) 19-Inch Electrohome Color Raster-Scan Display or 19-Inch Wells Gardner Color Raster-Scan Display Metal Support Bracket
038804-02 038805-01 038808-01 038992-01	Display Shelf Display Shield Retainer Display Bezel Display Shield

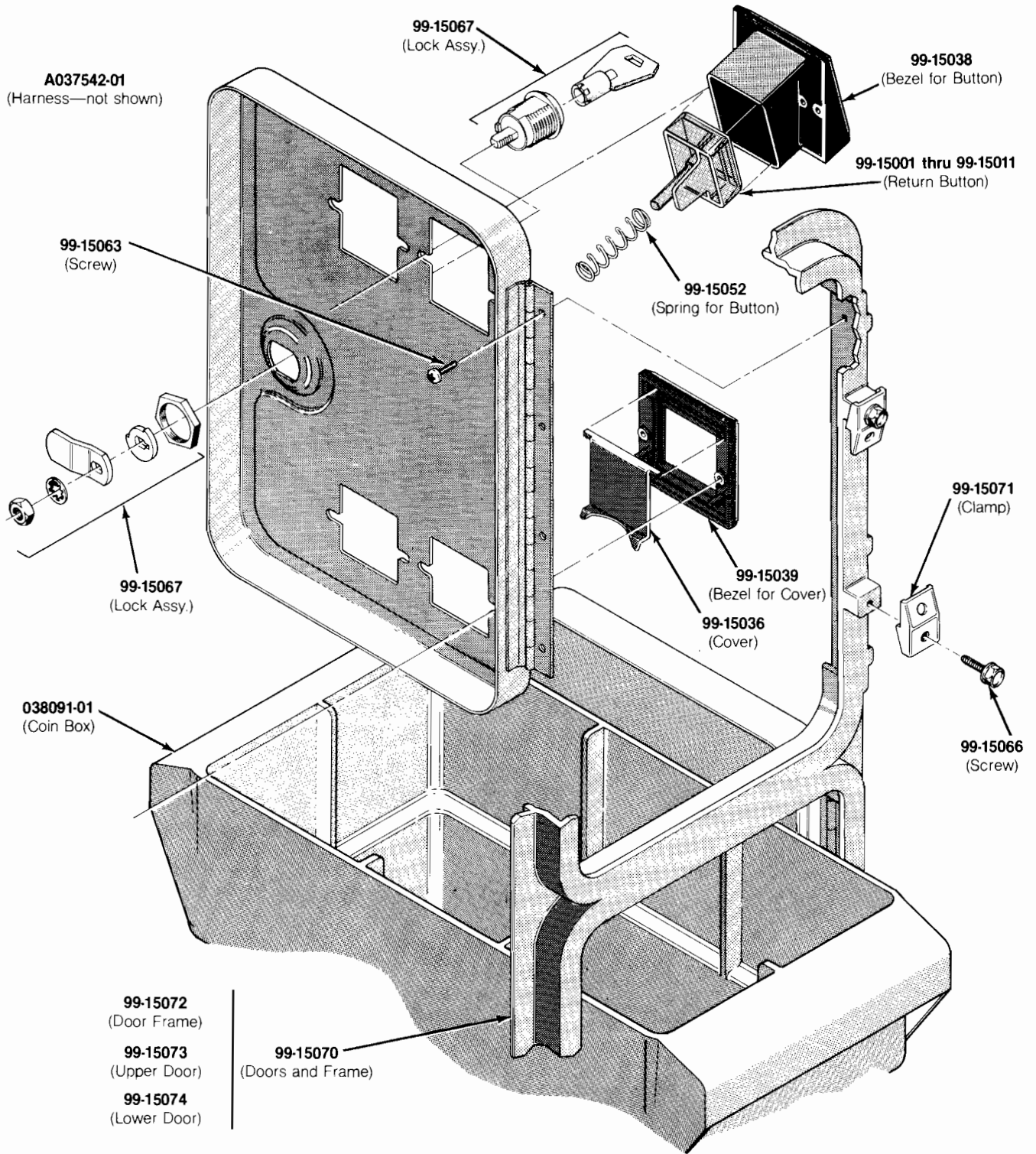


**Figure 3-9 Utility Panel Assembly
 A038002-01 & -02 G
 Parts List**

Part No.	Description
A002465-01	6 V Coin Counter
A038004-01	Utility Panel Harness
19-9032	Volume Control
62-041	SPDT Momentary-Contact Pushbutton Auxiliary Coin Switch with Black Cap
69-001	DPDT Self-Test Switch
038003-01	Utility Panel
75-9910W0	1 $\frac{1}{32}$ -32 Stamped Nut
176018-002	#6-32 x $\frac{1}{2}$ -Inch Machine Screw
178070-001	Volume Control Knob
179125-001	Grounding Clip (not shown)



**Figure 3-10 Vertically Mounted Coin Door
171034-xxx A**



171034-001 — U.S. 25¢/25¢ Coin Door
 171034-003 — Canadian 25¢/25¢ Coin Door
 171034-005 — U.K. 10 P/50 P Coin Door

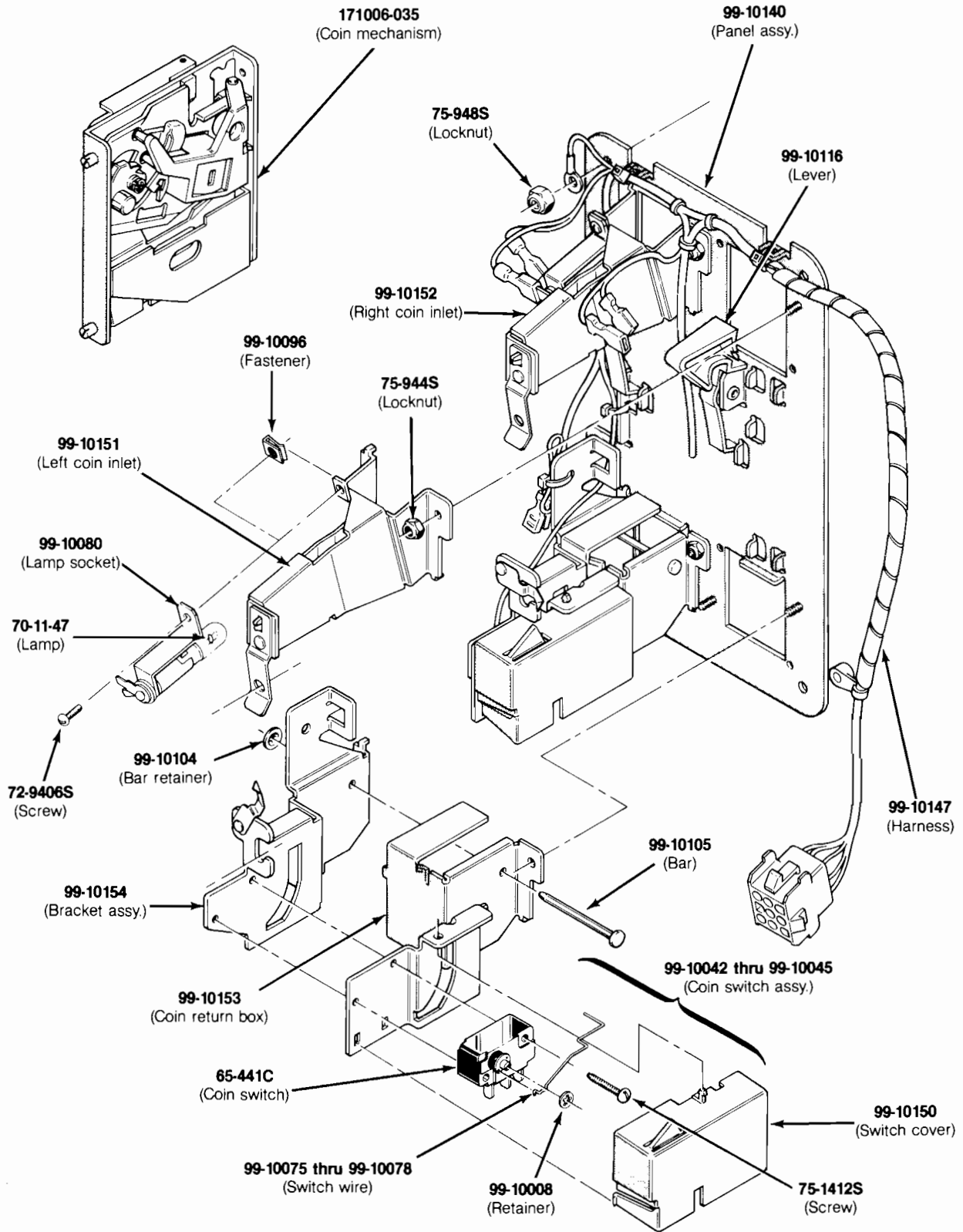
171034-006 — U.K. 20 P/50 P Coin Door
 171034-009 — German 2 DM/1 DM Coin Door
 171034-010 — German 2 DM/5 DM Coin Door

171034-011 — German 1 DM/5 DM Coin Door
 171034-015 — French 2 Fr/1 Fr Coin Door

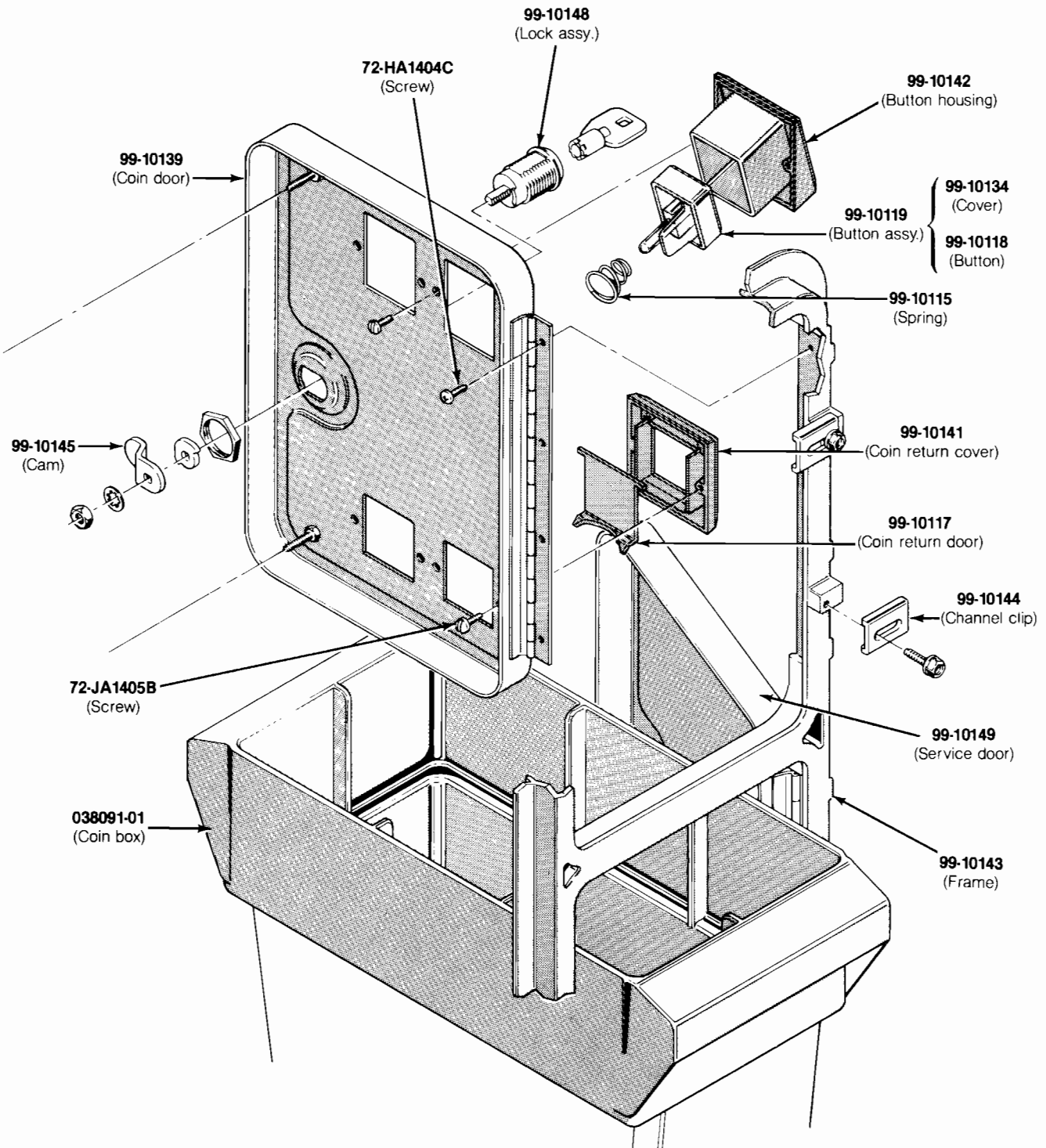
Figure 3-10 Vertically Mounted Coin Door, continued
171034-xxx A

Vertically Mounted Coin Door Parts List

<i>Part No.</i>	<i>Description</i>
A037542-01	Harness Assembly
72-1414S	#4-40 × 7/8-Inch Cross-Recessed Pan-Head Steel Machine Screw
75-056	#6 Internal-Tooth Zinc-Plated Steel Lock Washer
75-914S	#4-40 Steel Machine Hex Nut
75-3414S	#4-40 × 7/8-Inch 82° Cross-Recessed Flat-Head Steel Machine Screw
99-15001	Coin Return Button with U.S. 25¢ Price Plate
99-15002	Coin Return Button with U.S. \$1 Price Plate
99-15003	Coin Return Button with German 1 DM Price Plate
99-15004	Coin Return Button with German 2 DM Price Plate
99-15005	Coin Return Button with German 5 DM Price Plate
99-15006	Coin Return Button with Belgian 5 Fr Price Plate
99-15007	Coin Return Button with French 1 Fr Price Plate
99-15008	Coin Return Button with Japanese 100 Yen Price Plate
99-15009	Coin Return Button with British 10 Pence Price Plate
99-15010	Coin Return Button with Australian 20¢ Price Plate
99-15011	Coin Return Button with Italian 100 Lire Price Plate
99-15023	Base Plate
99-15025	Left Half of Coin Inlet
99-15026	Right Half of Coin Inlet
99-15027	Side Plate of Coin Return Box
99-15028	Base Plate of Coin Return Box
99-15029	Switch Bracket
99-15036	Metal Coin Return Cover
99-15038	Bezel for Coin Return Button
99-15039	Metal Bezel for Coin Return Cover
99-15040	Coin Return Lever
99-15042	Coin Switch for U.S. 25¢
99-15052	Spring for Coin Return Button
99-15054	Pivot for Coin Return Lever
99-15055	Retaining Screw
99-15056	#4-40 × 7/16-Inch Cross-Recessed Pan-Head Steel Machine Screw
99-15060	Switch Cover
99-15063	Screw for Hinge
99-15066	Screw for Clamp
99-15067	Lock Assembly
99-15070	Doors and Frame
99-15071	Clamp for Frame
99-15072	Door Frame
99-15073	Upper Door
99-15074	Lower Door
99-15075	Switch Adjuster
038091-01	Coin Box (Not included in assembly—Acceptable substitute is part number A037491-01)
170000-001	6.3 V Miniature Wedge-Base Incandescent Lamp
171006-035	Metal Coin Mechanism
179047-001	Lamp Base



**Figure 3-11 American-Made Coin Door Assembly
171027-001 A**



171034-001 — U.S. 25¢/25¢ Coin Door
 171034-003 — Canadian 25¢/25¢ Coin Door
 171034-005 — U.K. 10 P/50 P Coin Door

171034-006 — U.K. 20 P/50 P Coin Door
 171034-009 — German 2 DM/1 DM Coin Door
 171034-010 — German 2 DM/5 DM Coin Door

171034-011 — German 1 DM/5 DM Coin Door
 171034-015 — French 2 Fr/1 Fr Coin Door

Figure 3-11 American-Made Coin Door Assembly, continued
171027-001 A

American-Made Coin-Door Assembly Parts List

Part No.	Description
171006-035	Metal Coin Mechanism for U.S. \$.25
65-441C	Coin Switch
70-11-47	Miniature Bayonet Lamp
72-9406S	#4-40 x 3/8-Inch Truss-Head Screw
72-HA1404C	#4-40 x 1/4-Inch Pan-Head Screw
72-JA1405B	#4-40 x .31-Inch Pan-Head Screw
75-1412S	#4-40 x 3/4-Inch Pan-Head Screw
75-944S	#4-40 Locknut
99-10008	Retainer
99-10042	Coin Switch Assembly for Belgian 5 Fr and U.S. \$.25
99-10043	Coin Switch Assembly for German 1 DM, Japanese 100 Yen, Swiss 1 Fr
99-10044	Coin Switch Assembly for German 2 DM, Italian 100 L, U.S. \$1.00
99-10045	Coin Switch Assembly for Australian \$.20, German 5 DM, British 10 P
99-10068	Coin Return Chute
99-10075	Switch wire (included in coin switch assembly)
99-10076	Switch wire (included in coin switch assembly)
99-10077	Switch wire (included in coin switch assembly)
99-10078	Switch wire (included in coin switch assembly)
99-10080	Lamp socket
99-10081	Key holder
99-10096	Fastener
99-10104	Bar retainer
99-10105	Bar
99-10115	Spring
99-10116	Plastic Coin Return Lever
99-10117	Steel Coin Return Door
99-10118	Amber Coin Return Button
99-10119	Amber Coin Button for U.S. \$.25
99-10134	Coin Button Cover
99-10139	Coin Door
99-10140	Coin Door Inner-Panel Assembly
99-10141	Diecast Coin Return Cover
99-10142	Diecast Button Housing
99-10143	Coin Door Frame
99-10144	Coin Door Channel Clip
99-10145	Offset Cam
99-10146	Coin Inlet Chute Assembly
99-10147	American-Made Coin Door Harness
99-10148	Lock Assembly
99-10149	Service Door
99-10150	Switch Cover
99-10151	Left Coin Inlet
99-10152	Right Coin Inlet
99-10153	Coin Return Box
99-10154	Bracket Assembly

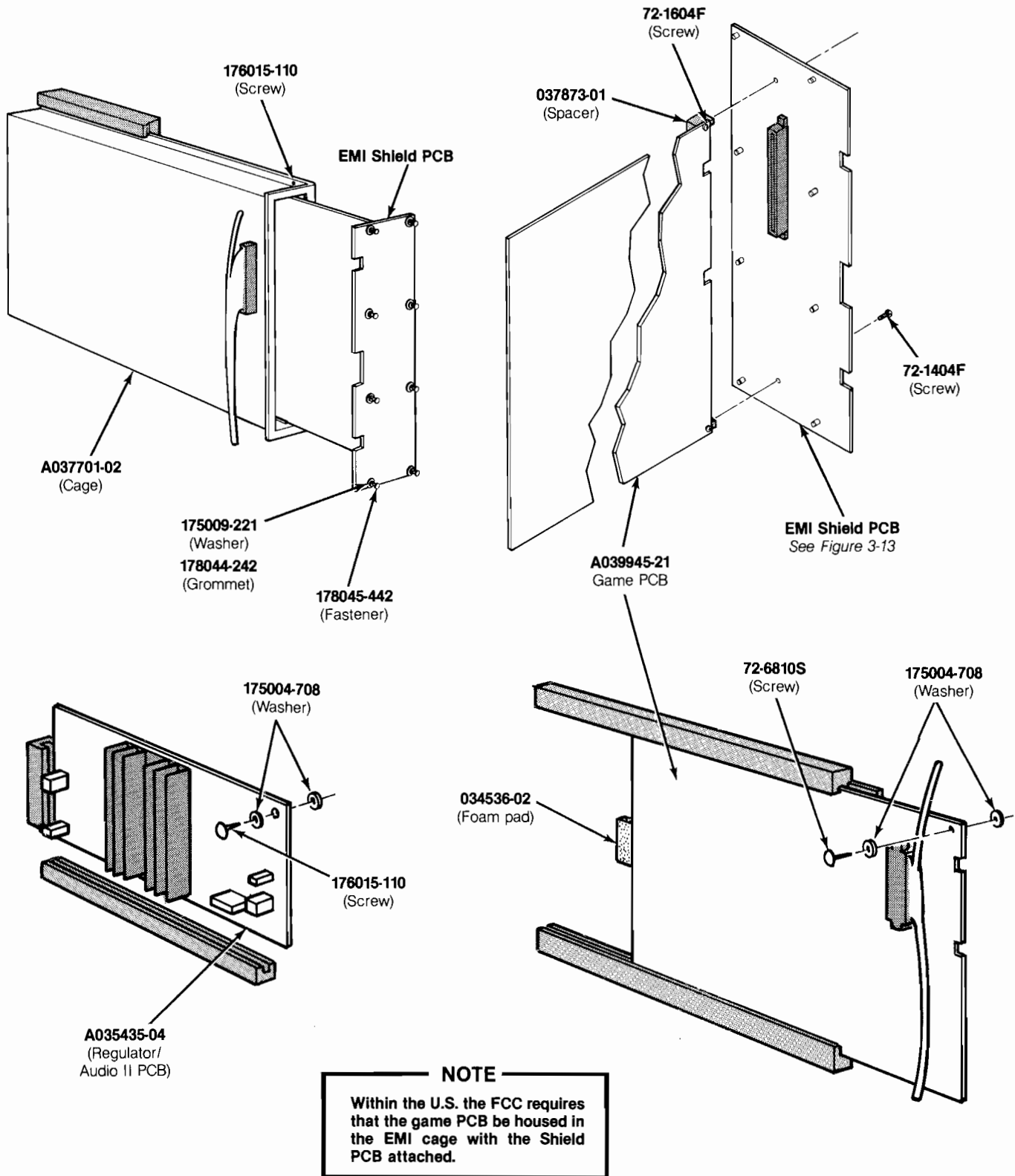
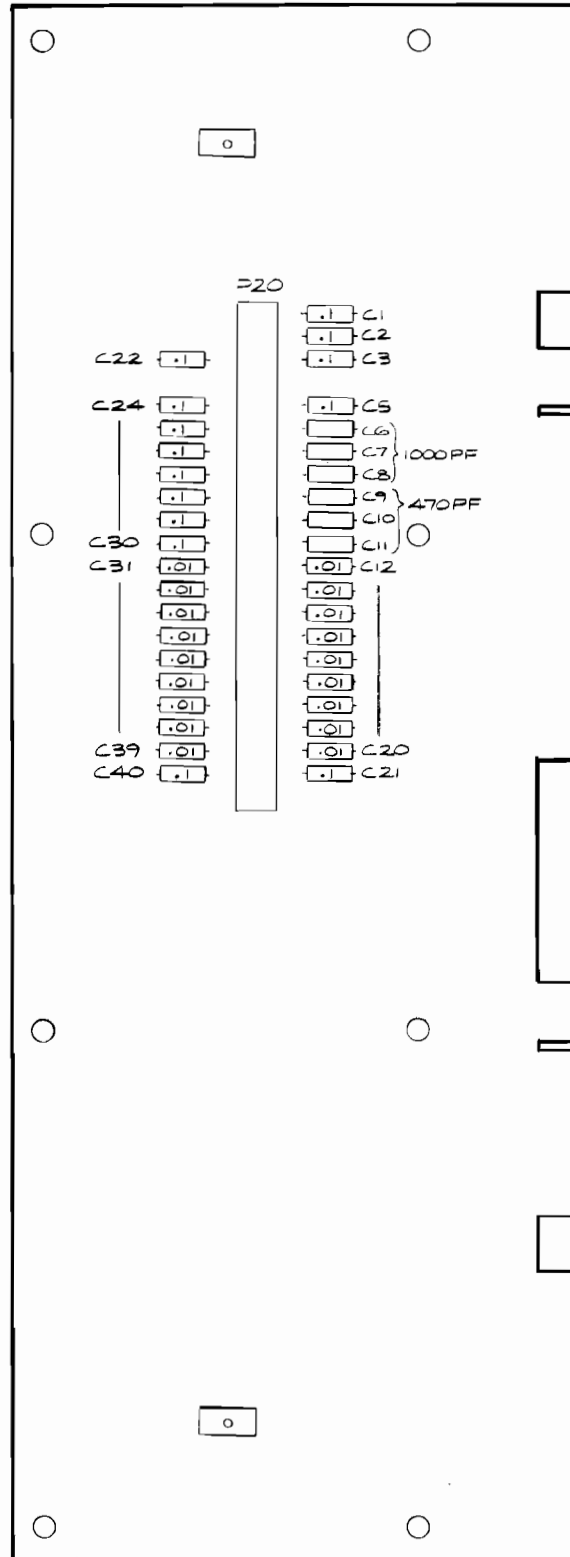


Figure 3-12 Electromagnetic Interference (EMI) Cage Assembly and Printed-Circuit Board Mounting Hardware

EMI Cage Assembly and Printed-Circuit Board Mounting Hardware Parts List

Part No.	Description
<i>US-Built Game</i>	
A037701-02	EMI Cage (includes guide)
A037430-02	EMI Shield PCB
72-1404F	#4-40 × ¼-Inch Cross-Recessed Steel Screw
72-1604F	#6-32 × ¼-Inch Cross-Recessed Steel Screw
037873-01	Spacer
175004-708	#8 Flat Fiber Washer
175009-221	Plastic Washer
176015-110	#10 x ⅝-Inch Cross-Recessed Pan-Head Screw
178044-242	Grommet
178045-442	Snap-In Fastener
179125-001	Grounding Clip (not shown)
<i>Ireland-Built Game</i>	
034536-02	Foam Pad
175004-708	#8 Flat Fiber Washer
72-6810S	#8 x ⅝-Inch Cross-Recessed Pan-Head Screw

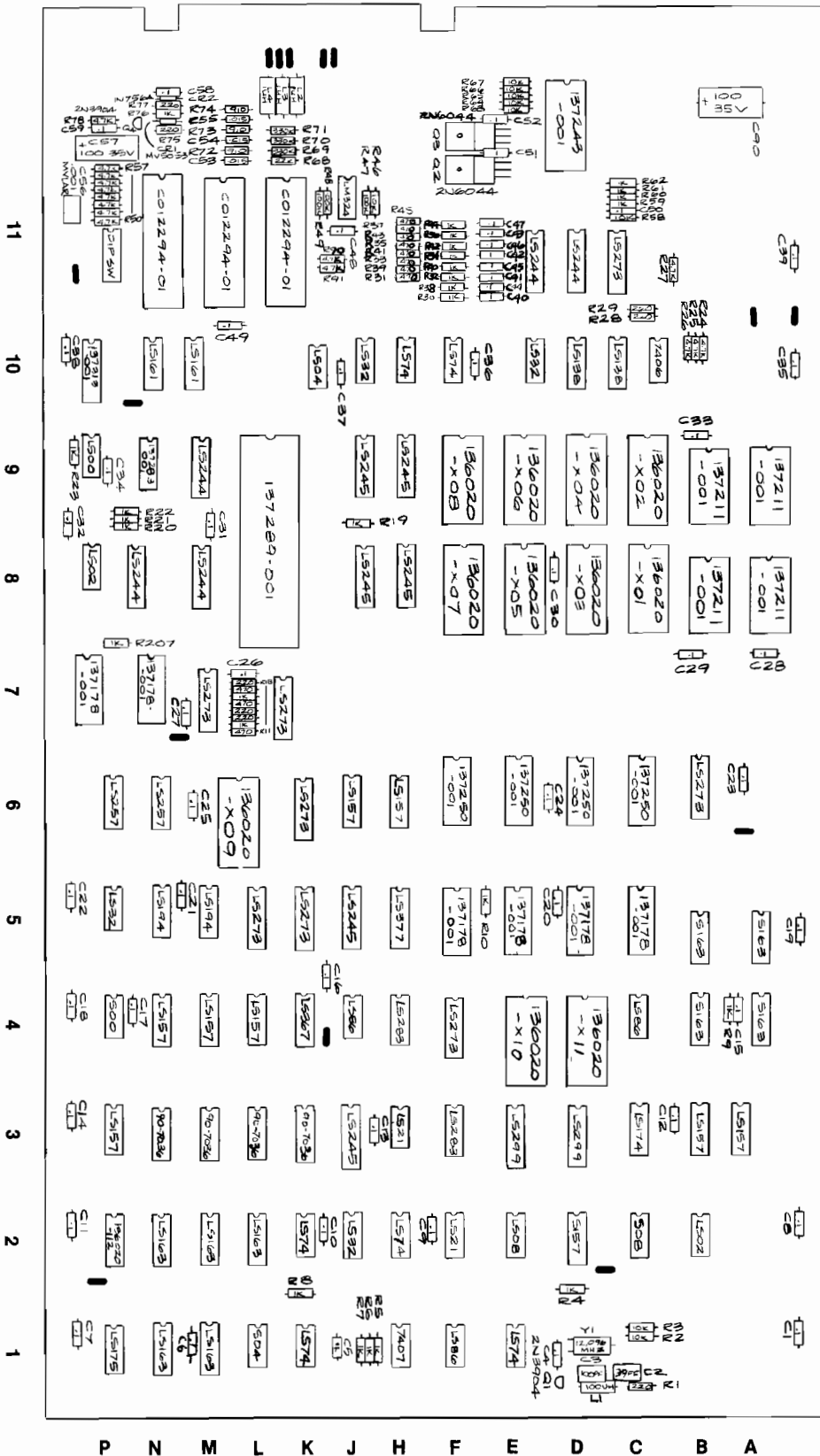


NOTICE TO ALL PERSONS RECEIVING THIS DRAWING
 CONFIDENTIAL: Reproduction forbidden without the specific written permission of Atari, Inc., Sunnyvale, CA. This drawing is only conditionally issued, and neither receipt nor possession thereof confers or transfers any right in, or license to use, the subject matter of the drawing or any design or technical information shown thereon, nor any right to reproduce this drawing or any part thereof. Except for manufacture by vendors of Atari, Inc., and for manufacture under the corporation's written license, no right to reproduce this drawing is granted or the subject matter thereof unless by written agreement with or written permission from the corporation.

**Figure 3-13 EMI Shield PCB Assembly
 A040253-01 A**

EMI Shield PCB Assembly Parts List

Designator	Description	Part No.
<i>Capacitors</i>		
C1-C3	0.1 μ F, +80% -20%, 50 V Ceramic-Disk Capacitor	122002-104
C5	0.1 μ F, +80% -20%, 50 V Ceramic-Disk Capacitor	122002-104
C6-C8	1000 pF, \pm 5%, 100 V, NPO Ceramic-Disk Axial-Lead Capacitor (Acceptable substitute is part no. 122002-102)	122016-102
C9-C11	470 pF, 100 V, NPO Ceramic-Disk Axial-Lead Capacitor (Acceptable substitute is part no. 122013-471)	122016-471
C12-C20	0.01 μ F, +80% -20%, 25 V Ceramic-Disk Axial-Lead Capacitor	122005-103
C21, C22	0.1 μ F, +80% -20%, 50 V Ceramic-Disk Capacitor	122002-104
C24-C30	0.1 μ F, +80% -20%, 50 V Ceramic-Disk Capacitor	122002-104
C31-C39	0.01 μ F, +80% -20%, 25 V Ceramic-Disk Axial-Lead Capacitor	122005-103
C40	0.1 μ F, +80% -20%, 50 V Ceramic-Disk Capacitor	122002-104
<i>Connector</i>		
P20	44-Pin Card-Edge Connector (Acceptable substitute is part no. 179046-044)	179073-044



NOTICE TO ALL PERSONS RECEIVING THIS DRAWING
 CONFIDENTIAL: Reproduction forbidden without the specific written permission of Atari, Inc., Sunnyvale, CA. This drawing is only conditionally issued, and neither receipt nor possession thereof confers or transfers any right in, or license to use, the subject matter of the drawing or any design or technical information shown thereon, nor any right to reproduce this drawing or any part thereof. Except for manufacture by vendors of Atari, Inc., and for manufacture under the corporation's written license, no right to reproduce this drawing is granted or the subject matter thereof unless by written agreement with or written permission from the corporation.

Figure 3-14 Food Fight Game PCB Assembly A039445-21 B

Food Fight Game Printed-Circuit Board Assembly Parts List

Designator	Description	Part No.
Capacitors		
C1	0.1 μ F, +80%, -20%, 50 V, Ceramic Capacitor	122002-104
C2	39 pF, 100 V Minimum, Dipped, Fixed-Mica Capacitor	128002-390
C3	100 pF, 100 V Minimum, Dipped, Fixed-Mica Capacitor	128002-101
C4	0.1 μ F, +80%, -20%, 50 V, Ceramic Capacitor	122002-104
C5-C39	0.1 μ F, +80%, -20%, 50 V, Ceramic Capacitor	122002-104
C40-C47	0.1 μ F, +80%, -20%, 50 V, Ceramic Capacitor	122002-104
C48, C49	0.1 μ F, +80%, -20%, 50 V, Ceramic Capacitor	122002-104
C50-C52	0.1 μ F, +80%, -20%, 50 V, Ceramic Capacitor	122002-104
C53-C55	0.015 μ F, \pm 10%, 100 V, Radial-Lead Mylar Capacitor	21-101153
C56	0.001 μ F, \pm 10%, 100 V, Radial-Lead Mylar Capacitor	21-101102
C57	100 μ F, 35 V Aluminum Electrolytic Axial-Lead Capacitor	24-350107
C58, C59	0.1 μ F, +80% -20%, 50 V, Ceramic Capacitor	122002-104
C60	120 μ F, 100 V Mica Capacitor (Acceptable substitute is part no. 128002-151)	128002-221
C90	100 μ F, 35 V Aluminum Electrolytic Axial-Lead Capacitor	24-350107
Diodes		
CR1	Type-MV5053 Light-Emitting Diode	38-MV5053
CR2	Type-1N756A, \pm 5%, 500 mW, 8.2 V Zener Diode	32-1N756A
Inductors		
L1	100 μ H, \pm 10% Inductor	141002-001
L2-L4	1 μ H, \pm 10%, 830 mA, 0.29 Ω , Peaking Coil Inductor	141007-001
Integrated Circuits		
1E	Type-74LS74 Integrated Circuit	37-74LS74
1F	Type-74LS86 Integrated Circuit	37-74LS86
1H	Type-7407 Integrated Circuit	37-7407
1K	Type-74LS74 Integrated Circuit	37-74LS74
1L	Type-74S04 Integrated Circuit	37-74S04
1M	Type-74LS163A Integrated Circuit	37-74LS163A
1N	Type-74LS163A Integrated Circuit	37-74LS163A
1P	Type-74LS175 Integrated Circuit	37-74LS175
2B	Type-74LS02 Integrated Circuit	37-74LS02
2C	Type-74S08 Integrated Circuit	37-74S08
2D	Type-74S157 Integrated Circuit	37-74S157
2E	Type-74LS08 Integrated Circuit	37-74LS08
2F	Type-74LS21 Integrated Circuit	137210-001
2H	Type-74LS74 Integrated Circuit	37-74LS74
2J	Type-74LS32 Integrated Circuit	37-74LS32
2K	Type-74LS74 Integrated Circuit	37-74LS74
2L	Type-74LS163A Integrated Circuit	37-74LS163A
2M	Type-74LS163A Integrated Circuit	37-74LS163A
2N	Type-74LS163A Integrated Circuit	37-74LS163A
2P	PROM Integrated Circuit	136020-112

(Continued on next page)

Food Fight Game Printed-Circuit Board Assembly Parts List, continued

Designator	Description	Part No.
3A	Type-74LS157 Integrated Circuit	37-74LS157
3B	Type-74LS157 Integrated Circuit	37-74LS157
3C	Type-74LS174 Integrated Circuit	37-74LS174
3D	Type-74LS299 Integrated Circuit	137180-001
3E	Type-74LS299 Integrated Circuit	137180-001
3F	Type-74LS283 Integrated Circuit	137204-001
3H	Type-74LS21 Integrated Circuit	137210-001
3J	Type-74LS245 Integrated Circuit	37-74LS245
3P	Type-74LS157 Integrated Circuit	37-74LS157
4A	Type-74S163 Integrated Circuit	137274-001
4B	Type-74S163 Integrated Circuit	137274-001
4C	Type-74LS86 Integrated Circuit	37-74LS86
4F	Type-74LS273 Integrated Circuit	37-74LS273
4H	Type-74LS283 Integrated Circuit	137204-001
4J	Type-74LS86 Integrated Circuit	37-74LS86
4K	Type-74LS367 Integrated Circuit	37-74LS367
4L	Type-74LS157 Integrated Circuit	37-74LS157
4M	Type-74LS157 Integrated Circuit	37-74LS157
4N	Type-74LS157 Integrated Circuit	37-74LS157
4P	Type-74S00 Integrated Circuit	37-74S00
5A	Type-74S163 Integrated Circuit	137274-001
5B	Type-74S163 Integrated Circuit	137274-001
5H	Type-74LS377 Integrated Circuit	37-74LS377
5J	Type-74LS245 Integrated Circuit	37-74LS245
5K	Type-74LS273 Integrated Circuit	37-74LS273
5L	Type-74LS273 Integrated Circuit	37-74LS273
5M	Type-74LS194 Integrated Circuit	37-74LS194
5N	Type-74LS194 Integrated Circuit	37-74LS194
5P	Type-74LS32 Integrated Circuit	37-74LS32
6B	Type-74LS273 Integrated Circuit	37-74LS273
6H	Type-74LS157 Integrated Circuit	37-74LS157
6J	Type-74LS157 Integrated Circuit	37-74LS157
6K	Type-74LS273 Integrated Circuit	37-74LS273
6N	Type-74LS257 Integrated Circuit	37-74LS257
6P	Type-74LS257 Integrated Circuit	37-74LS257
7K/L	Type-74LS273 Integrated Circuit	37-74LS273
7M	Type-74LS273 Integrated Circuit	37-74LS273
8K/L	Microprocessor Integrated Circuit	137289-001
8M	Type-74LS244 Integrated Circuit	37-74LS244
8N/P	Type-74LS244 Integrated Circuit	37-74LS244
8H	Type-74LS245 Integrated Circuit	37-74LS245
8H/J	Type-74LS245 Integrated Circuit	37-74LS245
8P	Type-74LS02 Integrated Circuit	37-74LS02
9H	Type-74LS245 Integrated Circuit	37-74LS245

(Continued on next page)

Food Fight Game Printed-Circuit Board Assembly Parts List, continued

Designator	Description	Part No.
9H/J	Type-74LS245 Integrated Circuit	37-74LS245
9K/L	Microprocessor Integrated Circuit	137289-004
9M	Type-74LS244 Integrated Circuit	37-74LS244
9P	Type-74LS00 Integrated Circuit	37-74LS00
10J/K	Type-74LS14 Integrated Circuit	37-74LS14
10C	Type-7406 Integrated Circuit	37-7406
10E	Type-74LS32 Integrated Circuit	37-74LS32
10C/D	Type-74LS138 Integrated Circuit	137177-001
10D	Type-74LS138 Integrated Circuit	137177-001
10H/J	Type-74LS32 Integrated Circuit	37-74LS32
10H	Type-74LS74 Integrated Circuit	37-74LS74
10F	Type-74LS74 Integrated Circuit	37-74LS74
10M	Type-74LS161 Integrated Circuit	37-74LS161
10N	Type-74LS161 Integrated Circuit	37-74LS161
10P	Programmed Logic Array Integrated Circuit	137313-001
11C/D	Type-74LS273 Integrated Circuit	37-74LS273
11D	Type-74LS244 Integrated Circuit	37-74LS244
11E	Type-74LS244 Integrated Circuit	37-74LS244
11/12J	Quad Op-Amp Integrated Circuit	37-LM324
11K/L	Custom I/O Integrated Circuit	C012294-01
11L/M	Custom I/O Integrated Circuit	C012294-01
11N	Custom I/O Integrated Circuit	C012294-01
12D	D-to-A Converter Integrated Circuit	137243-001
Miscellaneous		
Q2, Q3	Nylon Snap-In Fastener	81-4302
	Test Point (Acceptable substitute is part no. 020670-01)	179051-002
Y1	12.096 MHz Crystal	144000-001
SW1	8-Station Single-Throw Dual-Inline Package Bit Switch	66-118P1T
Erasable Programmable Read-Only Memories		
4E	Erasable Programmable Read-Only Memory	136020-110
4D	Erasable Programmable Read-Only Memory	136020-111
6L/M	Erasable Programmable Read-Only Memory	136020-109
8C	Erasable Programmable Read-Only Memory	136020-301
8D	Erasable Programmable Read-Only Memory	136020-303
8E	Erasable Programmable Read-Only Memory	136020-305
8F	Erasable Programmable Read-Only Memory	136020-307
9C	Erasable Programmable Read-Only Memory	136020-302
9D	Erasable Programmable Read-Only Memory	136020-204
9E	Erasable Programmable Read-Only Memory	136020-306
9F	Erasable Programmable Read-Only Memory	136020-308
Random-Access Memory		
3K	Static RAM Integrated Circuit	90-7036
3L	Static RAM Integrated Circuit	90-7036
3M	Static RAM Integrated Circuit	90-7036
3N	Static RAM Integrated Circuit	90-7036

(Continued on next page)

Food Fight Game Printed-Circuit Board Assembly Parts List, continued

Designator	Description	Part No.
5C	Random-Access Memory	137178-001
5D	Random-Access Memory	137178-001
5E	Random-Access Memory	137178-001
5F	Random-Access Memory	137178-001
6C	Random-Access Memory	137250-001
6D	Random-Access Memory	137250-001
6E	Random-Access Memory	137250-001
6F	Random-Access Memory	137250-001
7N	Random-Access Memory	137178-001
7P	Random-Access Memory	137178-001
8A	Random-Access Memory	137211-001
8B	Random-Access Memory	137211-001
9A	Random-Access Memory	137211-001
9B	Random-Access Memory	137211-001
9N	Non-Volatile RAM Integrated Circuit	137288-001
Resistors		
R1	220 Ω , $\pm 5\%$, $\frac{1}{4}$ W Resistor	110000-221
R2, R3	10 k Ω , $\pm 5\%$, $\frac{1}{4}$ W Resistor	110000-103
R4	1 k Ω , $\pm 5\%$, $\frac{1}{4}$ W Resistor	110000-102
R5-R7	1 k Ω , $\pm 5\%$, $\frac{1}{4}$ W Resistor	110000-102
R8	1 k Ω , $\pm 5\%$, $\frac{1}{4}$ W Resistor	110000-102
R9	1 k Ω , $\pm 5\%$, $\frac{1}{4}$ W Resistor	110000-102
R10	1 k Ω , $\pm 5\%$, $\frac{1}{4}$ W Resistor	110000-102
R11	470 Ω , $\pm 5\%$, $\frac{1}{4}$ W Resistor	110000-471
R12	1 k Ω , $\pm 5\%$, $\frac{1}{4}$ W Resistor	110000-102
R13, R14	220 Ω , $\pm 5\%$, $\frac{1}{4}$ W Resistor	110000-221
R15	470 Ω , $\pm 5\%$, $\frac{1}{4}$ W Resistor	110000-471
R16	1 k Ω , $\pm 5\%$, $\frac{1}{4}$ W Resistor	110000-102
R17	470 Ω , $\pm 5\%$, $\frac{1}{4}$ W Resistor	110000-471
R18	220 Ω , $\pm 5\%$, $\frac{1}{4}$ W Resistor	110000-221
R19	1 k Ω , $\pm 5\%$, $\frac{1}{4}$ W Resistor	110000-102
R20-R23	1 k Ω , $\pm 5\%$, $\frac{1}{4}$ W Resistor	110000-102
R24-R27	4.7 k Ω , $\pm 5\%$, $\frac{1}{4}$ W Resistor	110000-472
R28	220 Ω , $\pm 5\%$, $\frac{1}{4}$ W Resistor	110000-221
R29	220 Ω , $\pm 5\%$, $\frac{1}{4}$ W Resistor	110000-221
R30	1 k Ω , $\pm 5\%$, $\frac{1}{4}$ W Resistor	110000-102
R31	470 Ω , $\pm 5\%$, $\frac{1}{4}$ W Resistor	110000-471
R32	1 k Ω , $\pm 5\%$, $\frac{1}{4}$ W Resistor	110000-102
R33	470 Ω , $\pm 5\%$, $\frac{1}{4}$ W Resistor	110000-471
R34	1 k Ω , $\pm 5\%$, $\frac{1}{4}$ W Resistor	110000-102
R35	470 Ω , $\pm 5\%$, $\frac{1}{4}$ W Resistor	110000-471
R36	1 k Ω , $\pm 5\%$, $\frac{1}{4}$ W Resistor	110000-102
R37	470 Ω , $\pm 5\%$, $\frac{1}{4}$ W Resistor	110000-471
R38	1 k Ω , $\pm 5\%$, $\frac{1}{4}$ W Resistor	110000-102

(Continued on next page)

Food Fight Game Printed-Circuit Board Assembly Parts List, continued

Designator	Description	Part No.
R39	470 Ω , $\pm 5\%$, $\frac{1}{4}$ W Resistor	110000-471
R40	1 k Ω , $\pm 5\%$, $\frac{1}{4}$ W Resistor	110000-102
R41	470 Ω , $\pm 5\%$, $\frac{1}{4}$ W Resistor	110000-471
R42	1 k Ω , $\pm 5\%$, $\frac{1}{4}$ W Resistor	110000-102
R43	470 Ω , $\pm 5\%$, $\frac{1}{4}$ W Resistor	110000-471
R44	1 k Ω , $\pm 5\%$, $\frac{1}{4}$ W Resistor	110000-102
R45	470 Ω , $\pm 5\%$, $\frac{1}{4}$ W Resistor	110000-471
R46	10 k Ω , $\pm 5\%$, $\frac{1}{4}$ W Resistor	110000-103
R47-R49	100 k Ω , $\pm 5\%$, $\frac{1}{4}$ W Resistor	110000-104
R50-R57	4.7 k Ω , $\pm 5\%$, $\frac{1}{4}$ W Resistor	110000-472
R58	10 k Ω , $\pm 5\%$, $\frac{1}{4}$ W Resistor	110000-103
R59-62	1 k Ω , $\pm 5\%$, $\frac{1}{4}$ W Resistor	110000-102
R63-R67	10 k Ω , $\pm 5\%$, $\frac{1}{4}$ W Resistor	110000-103
R68	22 k Ω , $\pm 5\%$, $\frac{1}{4}$ W Resistor	110000-223
R69-R71	330 k Ω , $\pm 5\%$, $\frac{1}{4}$ W Resistor	110000-334
R72-R74	910 Ω , $\pm 5\%$, $\frac{1}{4}$ W Resistor	110000-911
R75	220 Ω , $\pm 5\%$, $\frac{1}{4}$ W Resistor	110000-221
R76	1 k Ω , $\pm 5\%$, $\frac{1}{4}$ W Resistor	110000-102
R77	220 Ω , $\pm 5\%$, $\frac{1}{4}$ W Resistor	110000-221
R78	4.7 k Ω , $\pm 5\%$, $\frac{1}{4}$ W Resistor	110000-472
R79	330 Ω , $\pm 5\%$, $\frac{1}{4}$ W Resistor	110000-331
R90, R91	4.7 k Ω , $\pm 5\%$, $\frac{1}{4}$ W Resistor	110000-472
R207	1 k Ω , $\pm 5\%$, $\frac{1}{4}$ W Resistor	110000-102
Sockets		
4D	28-Contact Medium-Insertion-Force Integrated Circuit Socket	79-42C28
4E	28-Contact Medium-Insertion-Force Integrated Circuit Socket	79-42C28
5C	22-Contact Medium-Insertion-Force Integrated Circuit Socket	79-42C22
5D	22-Contact Medium-Insertion-Force Integrated Circuit Socket	79-42C22
5E	22-Contact Medium-Insertion-Force Integrated Circuit Socket	79-42C22
5F	22-Contact Medium-Insertion-Force Integrated Circuit Socket	79-42C22
6C	22-Contact Medium-Insertion-Force Integrated Circuit Socket	79-42C22
6D	22-Contact Medium-Insertion-Force Integrated Circuit Socket	79-42C22
6E	22-Contact Medium-Insertion-Force Integrated Circuit Socket	79-42C22
6F	22-Contact Medium-Insertion-Force Integrated Circuit Socket	79-42C22
6L/M	28-Contact Medium-Insertion-Force Integrated Circuit Socket	79-42C28
7N	22-Contact Medium-Insertion-Force Integrated Circuit Socket	79-42C22
7P	22-Contact Medium-Insertion-Force Integrated Circuit Socket	79-42C22
8A	24-Contact Medium-Insertion-Force Integrated Circuit Socket	79-42C24
8B	24-Contact Medium-Insertion-Force Integrated Circuit Socket	79-42C24
8C	28-Contact Medium-Insertion-Force Integrated Circuit Socket	79-42C28
8D	28-Contact Medium-Insertion-Force Integrated Circuit Socket	79-42C28
8E	28-Contact Medium-Insertion-Force Integrated Circuit Socket	79-42C28
8F	28-Contact Medium-Insertion-Force Integrated Circuit Socket	79-42C28
8K/L	64-Contact Medium-Insertion-Force Integrated Circuit Socket	79-42C64

(Continued on next page)

Food Fight Game Printed-Circuit Board Assembly Parts List, continued

Designator	Description	Part No.
9A	24-Contact Medium-Insertion-Force Integrated Circuit Socket	79-42C24
9B	24-Contact Medium-Insertion-Force Integrated Circuit Socket	79-42C24
9C	28-Contact Medium-Insertion-Force Integrated Circuit Socket	79-42C28
9D	28-Contact Medium-Insertion-Force Integrated Circuit Socket	79-42C28
9E	28-Contact Medium-Insertion-Force Integrated Circuit Socket	79-42C28
9F	28-Contact Medium-Insertion-Force Integrated Circuit Socket	79-42C28
9K/L	64-Contact Medium-Insertion-Force Integrated Circuit Socket	79-42C64
10P	20-Contact Medium-Insertion-Force Integrated Circuit Socket	79-42C20
11K/L	40-Contact Medium-Insertion-Force Integrated Circuit Socket	79-42C40
11L/M	40-Contact Medium-Insertion-Force Integrated Circuit Socket	79-42C40
11N	40-Contact Medium-Insertion-Force Integrated Circuit Socket	79-42C40
12D	28-Contact Medium-Insertion-Force Integrated Circuit Socket	79-42C28
Transistors		
Q1	Type-2N3904, 350 mW, 60 V NPN Transistor	34-2N3904
Q2, Q3	Type-2N6044, 8 A, 80 V NPN Transistor	34-2N6044
Q4	Type-2N3904, 350 mW, 60 V NPN Transistor	34-2N3904

NOTICE TO ALL PERSONS RECEIVING THIS DRAWING
 CONFIDENTIAL. Reproduction forbidden without the specific written permission of Atari, Inc., Sunnyvale, CA. This drawing is only conditionally issued, and neither receipt nor possession thereof confers or transfers any right in, or license to use, the subject matter of the drawing or any design or technical information shown thereon, nor any right to reproduce this drawing or any part thereof. Except for manufacture by vendors of Atari, Inc., and for manufacture under the corporation's written license, no right to reproduce this drawing is granted or the subject matter thereof unless by written agreement with or written permission from the corporation.

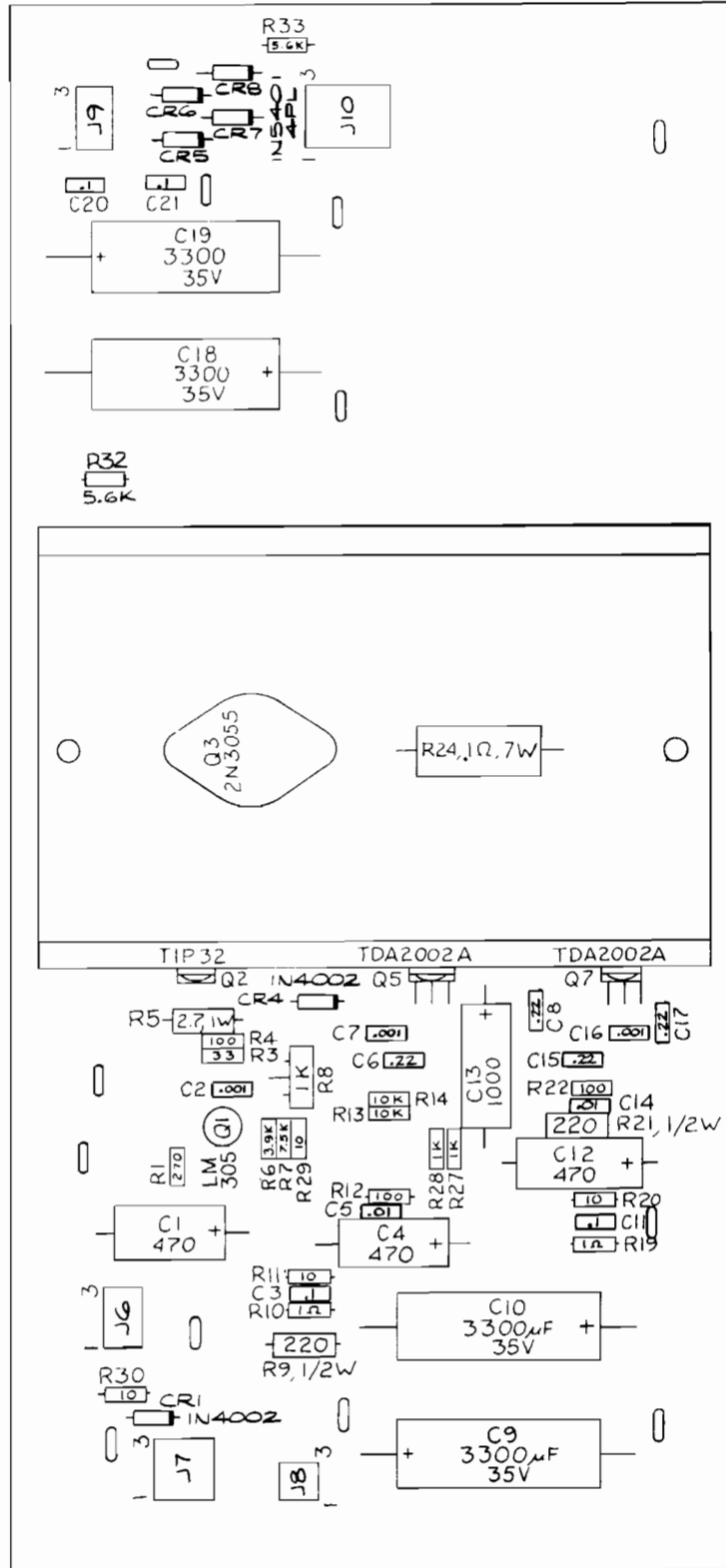


Figure 3-15 Regulator/Audio II PCB Assembly
A035435-04 K

Regulator/Audio II PCB Assembly Parts List

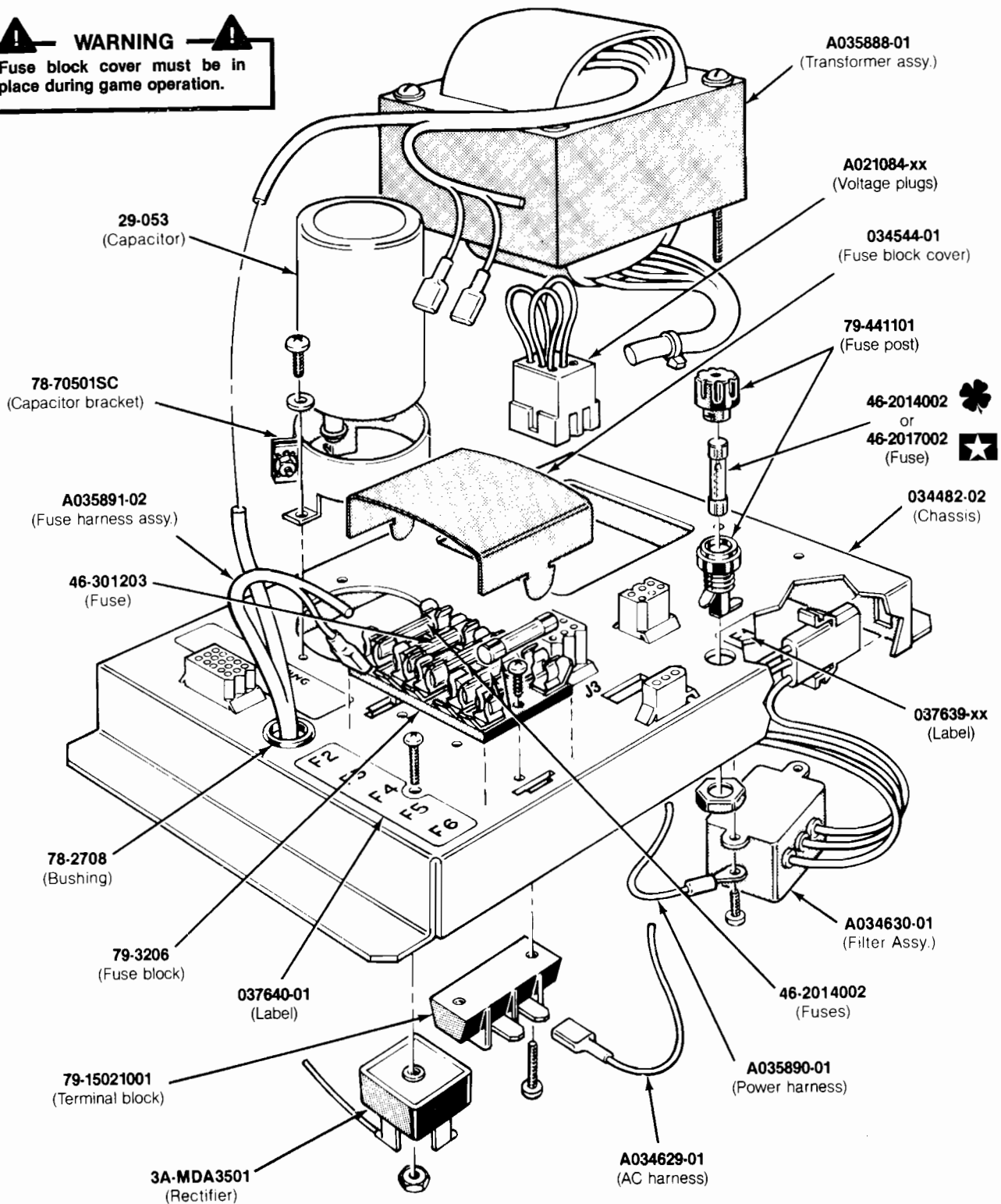
Designator	Description	Part No.
<i>Capacitors</i>		
C1	470 μ F, 25 V, Aluminum Electrolytic Fixed Axial-Lead Capacitor	24-250477
C2	0.001 μ F, 50 V, Ceramic-Disc Axial-Lead Capacitor	122002-102
C3	0.1 μ F, 50 V, Ceramic-Disc Axial-Lead Capacitor	122002-104
C4	470 μ F, 25 V, Aluminum Electrolytic Fixed Axial-Lead Capacitor	24-250477
C5	0.01 μ F, 25 V Minimum, Ceramic-Disc Axial-Lead Capacitor (Acceptable substitute is part no. 122005-103)	100015-103
C6	0.22 μ F, 25 V, Ceramic-Disc Axial-Lead Capacitor	122004-224
C7	0.001 μ F, 50 V, Ceramic-Disc Axial-Lead Capacitor	122002-102
C8	0.22 μ F, 25 V, Ceramic-Disc Axial-Lead Capacitor	122004-224
C9, C10	3300 μ F, 35 V, Aluminum Electrolytic Fixed Axial-Lead Capacitor	24-350338
C11	0.1 μ F, 50 V, Ceramic-Disc Axial-Lead Capacitor	122002-104
C12	470 μ F, 25 V, Aluminum Electrolytic Fixed Axial-Lead Capacitor	24-250477
C13	1000 μ F, 25 V, Aluminum Electrolytic Fixed Axial-Lead Capacitor	24-250108
C14	0.01 μ F, 25 V Minimum, Ceramic-Disc Axial-Lead Capacitor (Acceptable substitute is part no. 122005-103)	100015-103
C15	0.22 μ F, 25 V, Ceramic-Disc Axial-Lead Capacitor	122004-224
C16	0.001 μ F, 50 V, Ceramic-Disc Axial-Lead Capacitor	122002-102
C17	0.22 μ F, 25 V, Ceramic-Disc Axial-Lead Capacitor	122004-224
C18, C19	3300 μ F, 35 V, Aluminum Electrolytic Fixed Axial-Lead Capacitor	24-350338
C20, C21	0.1 μ F, 50 V, Ceramic-Disc Axial-Lead Capacitor	122002-104
<i>Diodes</i>		
CR1, C4	Type-1N4002, 1 A, 100 V Silicon Rectifier Diode	31-1N4002
CR5-CR8	Type-1N5401, 3 A, 100 V Silicon Rectifier Diode	31-1N5401
<i>Integrated Circuits</i>		
Q1	Type-LM305, 5 V, Linear Voltage Regulator	37-LM305
Q5	Type-TDA2002A, 8 W, Linear Audio Amplifier Integrated Circuit	137151-002
Q7	Type-TDA2002A, 8 W, Linear Audio Amplifier Integrated Circuit	137151-002
<i>Resistors</i>		
R1	270 Ω , $\pm 5\%$, $\frac{1}{4}$ W Resistor	110000-271
R3	33 Ω , $\pm 5\%$, $\frac{1}{4}$ W Resistor	110000-330
R4	100 Ω , $\pm 5\%$, $\frac{1}{4}$ W Resistor	110000-101
R5	2.7 Ω , $\pm 5\%$, 1 W Resistor	110009-027
R6	3.9 k Ω , $\pm 5\%$, $\frac{1}{4}$ W Resistor	110000-392
R7	7.5 k Ω , $\pm 5\%$, $\frac{1}{4}$ W Resistor	110000-752
R8	1 k Ω Horizontal PCB-Mounting Cermet Potentiometer (Acceptable substitute is part no. 19-315102)	119002-102
R9	220 Ω , $\pm 5\%$, $\frac{1}{2}$ W Resistor	110001-221
R10	1 Ω , $\pm 5\%$, $\frac{1}{4}$ W Resistor	110000-010
R11	10 Ω , $\pm 5\%$, $\frac{1}{4}$ W Resistor	110000-100
R12	100 Ω , $\pm 5\%$, $\frac{1}{4}$ W Resistor	110000-101
R13, R14	10 k Ω , $\pm 5\%$, $\frac{1}{4}$ W Resistor	110000-103

(Continued on next page)

Regulator/Audio II PCB Assembly Parts List, continued

Designator	Description	Part No.
R19	1 Ω , $\pm 5\%$, 1/4 W Resistor	110000-010
R20	10 Ω , $\pm 5\%$, 1/4 W Resistor	110000-100
R21	220 Ω , $\pm 5\%$, 1/2 W Resistor	110001-221
R22	100 Ω , $\pm 5\%$, 1/4 W Resistor	110000-101
R24	0.1 Ω , $\pm 3\%$, 7 W Wirewound Resistor	19-100P1015
R27, R28	1 k Ω , $\pm 5\%$, 1/4 W Resistor	110000-102
R29, R30	10 Ω , $\pm 5\%$, 1/4 W Resistor	110000-100
R32, R33	5.6 k Ω , $\pm 5\%$, 1/4 W Resistor	110000-562
<i>Transistors</i>		
Q2	Type-TIP32 PNP Power Transistor	33-TIP32
Q3	Type-2N3055 NPN Silicon Transistor	34-2N3055
<i>Mechanical Parts</i>		
J6	6-Position Connector Receptacle	79-58306
J7	9-Position Connector Receptacle	79-58308
J8	4-Position Connector Receptacle	79-58354
J9	6-Position Connector Receptacle	79-58306
J10	12-Position Connector Receptacle	79-58346
Q2	#6-32 x 1/4-Inch Binder-Head Nylon Screw	75-F60405
Q3	#6-32 Nut/Washer Assembly	75-99516
Q3	Thermally Conductive Silicon Insulator	78-16008
Q5	Thermally Conductive Silicon Insulator	78-16008
Q5, Q7	#6 x 3/8-Inch Cross-Recessed Pan-Head Thread-Forming Type-AB Zinc-Plated-Steel Screw	72-6606S
	Heat Sink	034531-01
	Test Point (Acceptable substitute is part no. 020670-01)	179051-001

WARNING
 Fuse block cover must be in place during game operation.



**Figure 3-16 Color Raster-Scan Power Supply Assembly
 A037671-01 & -03 H**

**Power Supply Assembly
Parts List
US-Built Game A037671-01 G**

Designator	Description	Part No.
C1	27,000 μ F, 15 VDC Electrolytic Capacitor	29-053
C1	2-Inch Diameter Capacitor Mounting Bracket	78-70501SC
CR1	Type-MDA 3501 Bridge Rectifier	3A-MDA3501
F1	Panel-Mounting Non-Indicating 3AG Cartridge-Type Fuse Post	79-441101
F1	7 A, 250 V, 3AG Slow-Blow Glass Cartridge-Type Fuse	46-2017002
F1	Label for Fuse Value	037639-01
F2	4 A, 250 V, 3AG Slow-Blow Glass Cartridge-Type Fuse	46-2014002
F2-F6	5-Position 3AG Fuse Block with $\frac{1}{4}$ -Inch Quick-Disconnect Terminals	79-3206
F2-F6	Fuse Harness Assembly	A035891-02
F2-F6	Fuse Block Cover	034544-01
F2-F6	Label for Fuse Values	037640-01
F3	20 A, 32 V, 3AG Slow-Blow Glass Cartridge-Type Fuse	46-301203
F4	2-Circuit Single-Row Terminal Block (located under F4)	79-15021001
F4-F6	4 A, 250 V, 3AG Slow-Blow Glass Cartridge-Type Fuse	46-2014002
FL1	RFI Filter Assembly (designation not marked)	A034630-01
J2	Power Harness Assembly	A035890-01
J3	Voltage Plug for 120 V (105-135 VAC) (yellow wire color—plugs into J3)	A021084-02
J4A	AC Harness Assembly	A034629-01
T1	Transformer Assembly (designation covered—Acceptable substitute is part no. A035888-02)	A035888-01
	Nylon Type 6/6 Hole Bushing with $\frac{5}{8}$ -Inch Inside Diameter x $\frac{5}{16}$ -Inch Outside Diameter x $\frac{1}{4}$ -Inch Thick	78-2708
	Power Supply Chassis Base	034482-02
	Metal Base Plate (not shown in illustration)	037243-01

**Power Supply Assembly
Parts List
Ireland-Built Game A037671-03 G**

Designator	Description	Part No.
C1	27,000 μ F, 15 VDC Electrolytic Capacitor	29-053
C1	2-Inch Diameter Capacitor Mounting Bracket	78-70501SC
CR1	Type-MDA 3501 Bridge Rectifier	3A-MDA3501
F1	Panel-Mounting Non-Indicating 3AG Cartridge-Type Fuse Post	79-441101
F1	Label for Fuse Value	037639-02
F1, F2	4 A, 250 V, 3AG Slow-Blow Glass Cartridge-Type Fuse	46-2014002
F2-F6	5-Position 3AG Fuse Block with $\frac{1}{4}$ -Inch Quick-Disconnect Terminals	79-3206
F2-F6	Fuse Harness Assembly	A035891-02
F2-F6	Fuse Block Cover	034544-01
F2-F6	Label for Fuse Values	037640-01
F3	20 A, 32 V, 3AG Slow-Blow Glass Cartridge-Type Fuse	46-301203
F4	2-Circuit Single-Row Terminal Block (located under F4)	79-15021001
F4-F6	4 A, 250 V, 3AG Slow-Blow Glass Cartridge-Type Fuse	46-2014002
FL1	RFI Filter Assembly (designation not marked)	A034630-01
J2	Power Harness Assembly	A035890-01
J3	Voltage Plug for 220 V (200-240 VAC) (blue wire color—plugs into J3)	A021084-04
J3	Voltage Plug for 240 V (220-260 VAC) (brown wire color—plugs into J3)	A021084-05
J4A	AC Harness Assembly	A034629-01
T1	Transformer Assembly (designation covered—Acceptable substitute is part no. A035888-02)	A035888-01
	Nylon Type 6/6 Hole Bushing with $\frac{3}{8}$ -Inch Inside Diameter x $\frac{5}{64}$ -Inch Outside Diameter x $\frac{1}{4}$ -Inch Thick	78-2708
	Power Supply Chassis Base	034482-02
	Metal Base Plate (not shown)	037243-01

Appendix A

Gimbal Joystick Maintenance and Repair

WARNING
Before removing or repairing the joystick, turn the game off.

Normal maintenance involves lubricating four parts in the joystick control approximately every three months (this requires removing the control). First, open the control panel. Tilt the control panel towards you. Then unsolder the harness from the two potentiometers on the joystick assembly.

From the inside of the control panel, remove the four flat washers, hex nuts, and carriage bolts that mount the joystick to the control panel.

Then open up the joystick control assembly by removing the four flat washers, hex nuts, and long screws (see Figure 3-4). At this point, most of the parts should disassemble.

For lubrication, use only Nyogel 779 lubricant (Atari part no. 178027-001). Lubricate the following parts inside the control:

- The insides of the two black linkages, located on the potentiometer shafts.
- The insides of the two gimbals, where the bottom of the shaft wears against them.
- The sides of the pivot ball housings at the four holes where the gimbals are attached.

If the bellows need replacing, remove both gimbals and the bellows cap. Slide the bellows off the bottom of the shaft. Slide the new bellows up over shaft.

Reassemble the joystick control, and then reinstall it in the control panel. Reconnect the harness wires as shown in Figure 3-3. **Make sure the right colors go to the tabs on the potentiometers.** Refer to Chapter 2, Self-Test Menu, for instructions on how to recalibrate the joystick.

If the square pattern control plate (part no. 036953-01) or mounting plate (part no. 036954-01) need replacing, disassemble the lower half of the control by removing the four hex nuts. Support the pivot ball of the pivot shaft assembly on a hard surface that has a hole slightly deeper than the length of the roll pin (see Figure A-1). Knock out the $\frac{3}{16}$ -inch roll pin using a $\frac{3}{16}$ -inch punch. Reassemble in reverse order.

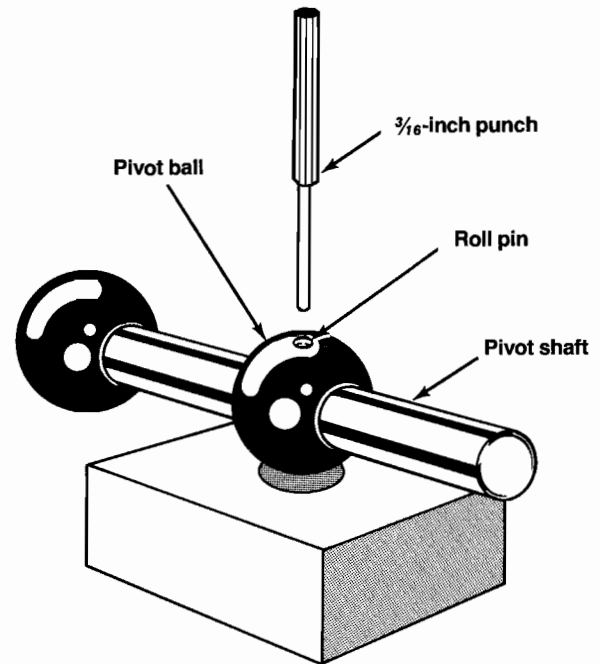


Figure A-1 Disassembling the Pivot Shaft Assembly

YOUR COMMENTS, PLEASE!

Your comments will assist Atari in improving our publications. The comments are an important part of preparing for revisions of game manuals. Please write in the space below. No postage stamp is necessary if mailed in the U.S.A.

If you have any technical questions about certain ATARI games products, or are requesting additional publications, we will immediately forward your note to the appropriate person.

Page: Comments:

Fill in if you wish a reply:

Name _____

Firm _____

Address _____

City _____ State _____ Zip _____

Area Code _____ Phone _____

Distributor

Operator

Other _____

First Fold



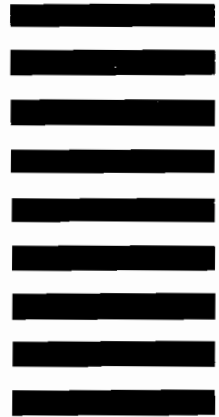
No postage
necessary if
mailed in the
United States

BUSINESS REPLY MAIL

FIRST CLASS PERMIT NO. 1004 SUNNYVALE, CA

POSTAGE WILL BE PAID BY ADDRESSEE

Atari, Inc.
Attn.: Field Service/Coin-Op Division
P.O. Box 427
Sunnyvale, California 94086



Second Fold

From: _____

Tape this edge

YOUR COMMENTS, PLEASE!

Your comments will assist Atari in improving our publications. The comments are an important part of preparing for revisions of game manuals. Please write in the space below.

If you have any technical questions about certain ATARI games products, or are requesting additional publications, we will immediately forward your note to the appropriate person.

Page: Comments:

Fill in if you wish a reply:

Name _____

Firm _____

Address _____

City _____ Country _____

Phone: Country Code _____ Local Number _____

Distributor

Operator

Other _____

First Fold

Attach
Necessary
Postage

Atari Ireland Limited
Attn.: Field Service/Coin-Op Division
Tipperary Town, Ireland

Second Fold

From:

Tape this edge

A decorative border with a repeating floral pattern of stylized flowers and leaves, framing the central text.

Warranty

Seller warrants that its printed-circuit boards and parts thereon are free from defects in material and workmanship under normal use and service for a period of ninety (90) days from date of shipment. Seller warrants that its video displays (in games supplied with displays) are free from defects in material and workmanship under normal use and service for a period of thirty (30) days from date of shipment. None of the Seller's other products or parts thereof are warranted.

If the products described in this manual fail to conform to this warranty, Seller's sole liability shall be, at its option, to repair, replace, or credit Buyer's account for such products which are returned to Seller during said warranty period, provided:

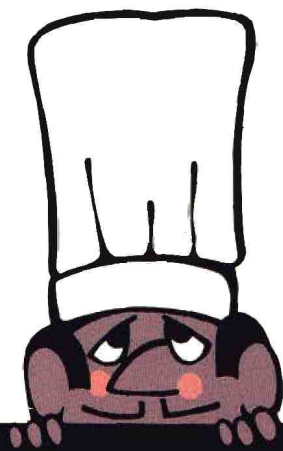
- (a) Seller is promptly notified in writing upon discovery by Buyer that said products are defective;
- (b) Such products are returned prepaid to Seller's plant; and
- (c) Seller's examination of said products discloses to Seller's satisfaction that such alleged defects existed and were not caused by accident, misuse, neglect, alteration, improper repair, installation, or improper testing.

In no event shall Seller be liable for loss of profits, loss of use, incidental or consequential damages.

Except for any express warranty set forth in a written contract between Seller and Buyer which contract supersedes the terms herein, this warranty is expressed in lieu of all other warranties expressed or implied, including the implied warranties of merchantability and fitness for a particular purpose, and of all other obligations or liabilities on the Seller's part, and it neither assumes nor authorizes any other person to assume for the Seller any other liabilities in connection with the sale of products by Seller.

The use of any non-Atari parts may void your warranty, according to the terms of the warranty. The use of any non-Atari parts may also adversely affect the safety of your game and cause injury to you and others. Be very cautious in using non-Atari-supplied components with our games, in order to insure your safety.

Atari distributors are independent, being privately owned and operated. In their judgment they may sell parts or accessories other than Atari parts or accessories. Atari cannot be responsible for the quality, suitability or safety of any non-Atari part or any modification including labor which is performed by such distributor.



ATARI, INC.
790 SYCAMORE DRIVE
P.O. BOX 906
MILPITAS, CALIFORNIA 95035
408/942-3100 • TELEX 35-7488

