

SEGA™

UNCONTROLLED

UNCONTROLLED

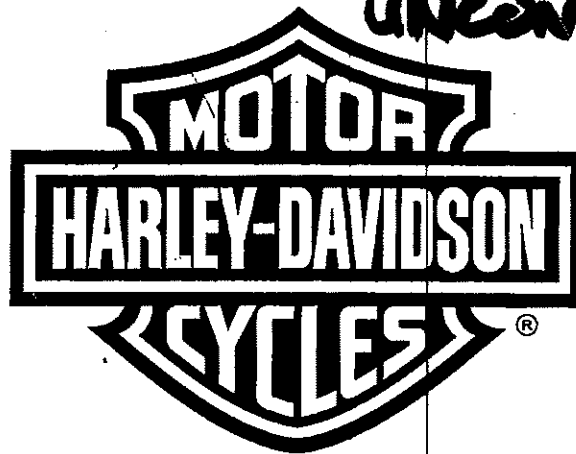

Harley-Davidson & L.A. Riders

DX TYPE

OWNER'S MANUAL

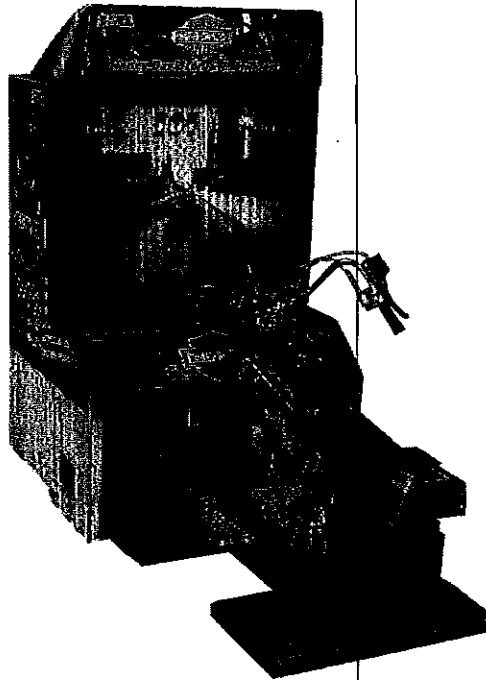

IMPORTANT!

- Before using this product, read this OWNER'S MANUAL carefully to understand the contents herein stated.
- After reading this manual, be sure to keep it available nearby the product or elsewhere convenient for referring to it anytime when necessary.

SEGA ENTERPRISES, LTD.

MANUAL NO. 420 - 6365 - 01

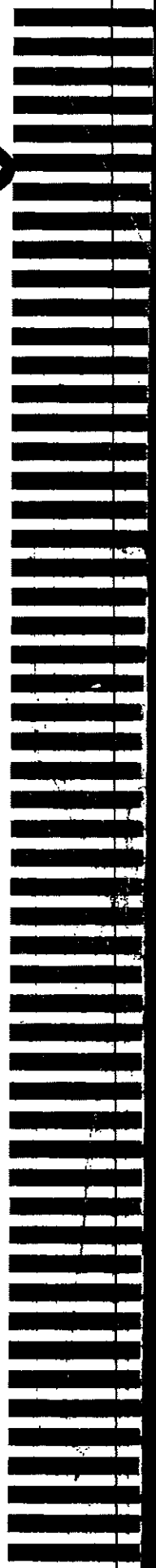

BEFORE USING THE PRODUCT, BE SURE TO READ THE FOLLOWING:

To maintain the safety:

To ensure the safe usage of the product, be sure to read the following before using the product. The following instructions are intended for the users, operators and the personnel in charge of the operation of the product. After carefully reading and sufficiently understanding the warning displays and cautions, handle the product appropriately. Be sure to keep this manual nearby the product or elsewhere convenient for referring to it when necessary.

Herein, explanations which require special attention are enclosed with dual lines. Depending on the potentially hazardous degrees, the terms of DANGER!, WARNING!, CAUTION!, etc. are used. Be sure to understand the contents of the displays before reading the text.



Indicates that mishandling the product by disregarding this pictograph will cause severe injury or death.



Indicates that mishandling the product by disregarding this caution will cause a slight hazardous situation which can result in personal injury and or material damage.



Indicates that mishandling the product by disregarding this warning will cause a potentially hazardous situation which can result in death or serious injury.



Indicates that mishandling the product by disregarding this display can cause the product's intrinsic performance not to be obtained, resulting in malfunctioning.

For the safe usage of the product, the following pictographs are used:



Indicates "HANDLE WITH CARE." In order to protect the human body and equipment, this display is attached to places where the Owner's Manual and or Service Manual should be referred to.



Indicates a "Protective Earth Terminal." Before operating the equipment, be sure to connect it to the Ground.

○ Perform work in accordance with the instructions herein stated.

Instructions for work are explained by paying attention to the aspect of accident prevention. Failing to perform work as per the instructions can cause accidents. In the case where only those who have technical expertise should perform the work to avoid hazardous situation, the instructions herein state that the serviceman should perform such work.

○ Be sure to turn off power before working on the machine.

To prevent electric shock, be sure to turn off power before starting the work in which the worker touches the interior of the product. If the work is to be performed in the power-on status, the Instruction Manual herein always states to that effect.

○ Be sure to ground the Earth Terminal (this, however, is not required in the case where a power cord with earth is used).

This product is equipped with the Earth Terminal. When installing the product, connect the Earth Terminal to the "accurately grounded indoor earth terminal" by using an earth wire. Unless the product is grounded appropriately, the user can be subject to electric shock. After performing repair, etc. for the Control equipment, ensure that the Earth Wire is firmly connected to the Control equipment.

○ Ensure that the Power Supply used is equipped with an Earth Leakage Breaker.

This product does not incorporate the Earth Leakage Breaker. Using a power supply which is not equipped with the Earth Leakage Breaker can cause a fire when earth leakage occurs.

○ Be sure to use fuses which meet the specified rating (only for the machines which use fuses).

Using fuses exceeding the specified rating can cause a fire and electric shock.

- **Specification changes (removal of equipment, conversion and addition) not designated by SEGA are not allowed.**

The parts of the product include warning labels for safety, covers for personal protection, etc. It is very hazardous to operate the product by removing parts and or modifying the circuits. Should doors, lids and protective parts be damaged or lost, refrain from operating the product, and contact where the product was purchased from or the office herein stated.

- **Ensure that the product meets the requirements of appropriate Electrical Specifications.**

Before installing the product, check for Electrical Specifications. SEGA products have a nameplate on which Electrical Specifications are described. Ensure that the product is compatible with the power supply voltage and frequency requirements of the location. Using any Electrical Specifications different from the designated Specifications can cause a fire and electric shock.

- **Install and operate the product in places where appropriate lighting is available, allowing warning labels to be clearly read.**

To ensure safety for the customers, labels and printed instructions describing potentially hazardous situation are applied to places where accidents can be caused. Ensure that where the product is operated has sufficient lighting allowing the warnings to be read. If any label is peeled off, apply it again immediately. Please place an order with where the product was purchased from or the office herein stated.

- **When handling the Monitor, be very careful. (Applies only to the product w/ monitor).**

Some of the monitor (TV) parts are subject to high tension voltage. Even after turning off power, some portions are still subject to high tension voltage sometimes. Monitor repair and replacement should be performed only by those technical personnel who have knowledge of electricity and technical expertise.

- **When transporting or reselling this product, be sure to attach this manual to the product.**

In the case where commercially available monitors and printers are used in this product, only the contents relating to this product are explained herein. Some commercially available equipment has functions and reactions not stated in this manual. Read this manual together with the specific Instruction Manual of such equipment.

- Descriptions herein contained may be subject to improvement changes without notice.
- The contents described herein are fully prepared with due care. However, should any question arise or errors be found, please contact SEGA.

INSPECTIONS IMMEDIATELY AFTER TRANSPORTING THE PRODUCT TO THE LOCATION.

Normally, at the time of shipment, SEGA products are in a status allowing for usage immediately after transporting to the location. Nevertheless, an irregular situation may occur during transportation. Before turning on power, check the following points to ensure that the product has been transported in a satisfactory status.

- Are there any dented portions or defects (cuts, etc.) on the external surfaces of the cabinet?
- Are Casters and Adjusters, damaged?
- Do the power supply voltage and frequency requirements meet with those of the location?
- Are all wiring connectors correctly and securely connected? Unless connected in the correct direction, connector connections can not be made accurately. Do not insert connectors forcibly.
- Do power cords have cuts and dents?
- Do the fuses used meet specified rating? Is the Circuit Protector in an energized status?
- Are all accessories available?
- Can all Doors and Lids be opened with the Accessory keys? Can Doors and Lids be firmly closed?

TABLE OF CONTENTS

BEFORE USING THE PRODUCT, BE SURE TO READ THE FOLLOWING:

INTRODUCTION OF THE OWNER'S MANUAL

1.	HANDLING PRECAUTIONS.....	1 ~ 2
2.	PRECAUTIONS CONCERNING INSTALLATION LOCATION.....	3 ~ 4
3.	OPERATION.....	5 ~ 7
4.	NAME OF PARTS.....	8
5.	ACCESSORIES.....	9 ~ 10
6.	ASSEMBLING AND PRECAUTIONS.....	11 ~ 20
7.	PRECAUTIONS TO BE HEEDED WHEN MOVING THE MACHINE.....	21
8.	CONTENTS OF GAME.....	22 ~ 24
9.	EXPLANATION OF TEST AND DATA DISPLAY.....	25 ~ 43
	9-1 SWITCH UNIT AND COIN METER.....	26
	9-2 TEST MODE.....	27
	9-3 MEMORY TEST.....	27 ~ 28
	9-4 BOUNDARY SCAN TEST.....	29
	9-5 INPUT TEST.....	30
	9-6 OUTPUT TEST.....	31
	9-7 SOUND TEST.....	32
	9-8 C. R. T. TEST.....	32
	9-9 GAME ASSIGNMENTS.....	33
	9-10 COIN ASSIGNMENTS.....	34 ~ 37
	9-11 NETWORK ASSIGNMENTS.....	38
	9-12 VOLUME ADJUSTMENTS.....	39 ~ 40
	9-13 REAL TIME CLOCK TEST.....	41
	9-14 BOOKKEEPING.....	42
	9-15 BACKUP DATA CLEAR.....	43
10.	HANDLEBAR.....	44 ~ 48
	10-1 ADJUSTING/REPLACING THE FRONT BRAKE VOLUME.....	44
	10-2 ADJUSTING/REPLACING THE ACCELERATOR VOLUME.....	45
	10-3 ADJUSTING/REPLACING THE HANDLEBAR VOLUME.....	46 ~ 47
	10-4 GREASING.....	48
11.	BIKE MECHA.....	49 ~ 52
	11-1 ADJUSTING AND REPLACING THE REAR BRAKE VOLUME.....	49 ~ 50
	11-2 GREASING.....	51
	11-3 REPLACEMENT OF SAFETY RUBBER.....	52
12.	COIN SELECTOR.....	53
13.	PROJECTOR.....	54 ~ 65
	13-1 CLEANING THE SCREEN.....	54
	13-2 MITSUBISHI PROJECTOR.....	55 ~ 56
	13-3 TOSHIBA PROJECTOR.....	57 ~ 65
14.	REPLACEMENT OF FLUORESCENT LAMP.....	66
15.	PERIODIC INSPECTION TABLE.....	67
16.	TROUBLESHOOTING.....	68 ~ 70
17.	GAME BOARD.....	71 ~ 73
	17-1 REMOVING THE GAME BOARD.....	71 ~ 72
	17-2 COMPOSITION OF GAME BOARD.....	73
18.	DESIGN RELATED PARTS.....	74
19.	COMMUNICATION PLAY.....	75 ~ 79
	19-1 INSTALLATION PRECAUTIONS.....	75
	19-2 CONNECTING THE COMMUNICATION CABLES.....	76 ~ 77
	19-3 SETTING FOR COMMUNICATION PLAY.....	78
	19-4 NETWORK CHECK.....	79
20.	PARTS LIST.....	80 ~ 119
21.	WIRE COLOR CODE TABLE.....	120
22.	WIRING DIAGRAM.....	121 ~ 122

SPECIFICATIONS

Installation space	: 1,140 mm (W) × 2,347 mm (D) (44.9 in. × 92.4 in.)
Height	: 1,966 mm (77.4 in.)
Weight	: Approx. 342 kg. (754.0 lbs.)
Power, maximum current	: 644W 7.07A (AC 110V 50 Hz AREA) 627W 6.89A (AC 110V 60 Hz AREA) 628W 6.36A (AC 120V 60 Hz AREA) 633W 3.53A (AC 220V 50 Hz AREA) 617W 3.43A (AC 220V 60 Hz AREA) 631W 3.37A (AC 230V 50 Hz AREA) 618W 3.30A (AC 230V 60 Hz AREA) 628W 3.21A (AC 240V 50 Hz AREA) 614W 3.13A (AC 240V 60 Hz AREA)
For TAIWAN Power, current	: 650W 7.0A (MAX.) 380W 4.3A (MIN.)
MONITOR	: 50 INCH PROJECTION DISPLAY

INTRODUCTION OF THE OWNER'S MANUAL

This Owner's Manual is intended to provide detailed descriptions together with all the necessary information covering the general operation of electronic assemblies, electromechanicals, servicing control, spare parts, etc. as regards the product, **Harley-Davidson & L. A. Riders DELUXE TYPE.**

This manual is intended for the owners, personnel and managers in charge of operation of the product. Operate the product after carefully reading and sufficiently understanding the instructions. If the product fails to function satisfactorily, non-technical personnel should under no circumstances touch the internal system. Please contact where the product was purchased from.

SEGA ENTERPRISES, INC. (U.S.A.)/CUSTOMER SERVICE
45133 Industrial Drive, Fremont, California 94538, U.S.A.
Phone : (415) 802-3100
Fax : (415) 802-1754

DEFINITION OF LOCATION MAINTENANCE MAN AND SERVICEMAN



Non-technical personnel who do not have technical knowledge and expertise should refrain from performing such work that this manual requires the location's maintenance man or a serviceman to carry out, or work which is not explained in this manual. Failing to comply with this instruction can cause a severe accident such as electric shock.

Ensure that parts replacement, servicing & inspections, and troubleshooting are performed by the location's maintenance man or the serviceman. It is instructed herein that particularly hazardous work should be performed by the serviceman who has technical expertise and knowledge.

The location's maintenance man and serviceman are herein defined as follows:

"Location's Maintenance Man" :

Those who have experience in the maintenance of amusement equipment and vending machines, etc., and also participate in the servicing and control of the equipment through such routine work as equipment assembly and installation, servicing and inspections, replacement of units and consumables, etc. within the Amusement Facilities and or locations under the management of the Owner and Owner's Operators of the product.

Activities of Location's Maintenance Man :

Assembly & installation, servicing & inspections, and replacement of units & consumables as regards amusement equipment, vending machines, etc.

Serviceman :

Those who participate in the designing, manufacturing, inspections and maintenance service of the equipment at an amusement equipment manufacturer.

Those who have technical expertise equivalent to that of technical high school graduates as regards electricity, electronics and or mechanical engineering, and daily take part in the servicing & control and repair of amusement equipment.

Serviceman's Activities :

Assembly & installation and repair & adjustments of electrical, electronic and mechanical parts of amusement equipment and vending machines.

1. HANDLING PRECAUTIONS

When installing or inspecting the machine, be very careful of the following points and pay attention to ensure that the player can enjoy the game safely.
Non-compliance with the following points or inappropriate handling running counter to the cautionary matters herein stated can cause personal injury or damage to the machine.



- Before performing the work, be sure to turn power off. Performing the work without turning power off can cause an electric shock or short circuit. In the case work should be performed in the status of power on, this manual always states to that effects.
- To avoid electric shock or short circuit, do not plug in or unplug quickly.
- To avoid electric shock, do not plug in or unplug with a wet hand.
- Do not expose Power Cords and Earth Wires on the surface, (floor, passage, etc.). If exposed, the Power Cords and Earth Wires are susceptible to damage. Damaged cords and wires can cause electric shock or short circuit.
- To avoid causing a fire or electric shock, do not put things on or damage Power Cords.
- When or after installing the product, do not unnecessarily pull the power cord. If damaged, the power cord can cause a fire or electric shock.
- In case the power cord is damaged, ask for replacement through where the product was purchased from or the office herein stated. Using the cord as is damaged can cause fire, electric shock or leakage.
- Be sure to perform grounding appropriately. Inappropriate grounding can cause an electric shock.
- Be sure to use fuses meeting specified rating. Using fuses exceeding the specified rating can cause a fire or electric shock.
- Completely make connector connections for IC BD and others. Insufficient insertion can cause an electric shock.
- To avoid causing a fire or electric shock, do not make Specification changes by removing, converting and making additions unless otherwise designated by SEGA.
- Be sure to perform periodic maintenance inspections herein stated.



- For the IC board circuit inspections, only the logic tester is allowed. The use of a multiple-purpose tester is not permitted, so be careful in this regard.
- The Projector is employed for this machine. The Projector's screen is susceptible to damage, therefore, be very careful when cleaning the screen. For details, refer to PROJECTOR.

CONCERNING THE STICKER DISPLAY

SEGA product has Stickers describing the product manufacture No. (Serial No.) and Electrical Specifications. Also it has a Sticker describing where to contact for repair and for purchasing parts. When inquiring about or asking for repair, mention the Serial No. and Name of Machine indicated on the Sticker. The Serial No. indicates the product register. Identical machines could have different parts depending on the date of production. Also, improvements and modifications might have been made after the publication of this Manual. In order to meet the above situations, mention the Serial No. when contacting the applicable places.

CONCERNING WARNING DISPLAYS

SEGA product has warning displays on Stickers, Labels and or printed instructions adhered / attached to or incorporated in the places where a potentially hazardous situation can arise. The warning displays are intended for accident prevention for the customers and for avoiding hazardous situation relating to maintenance and servicing work. There are some portions in the Cabinet, which are subject to high tension voltage, etc. where accidents can be caused only by touching. When performing the servicing work, be very careful of the warning displays. Especially, any complex repair and replacement work not mentioned herein, should be performed by those technical personnel who have knowledge of electricity and technical expertise. For the prevention of accidents, caution any customer whose act runs counter to the warnings, as to the effect that he must stop the act.

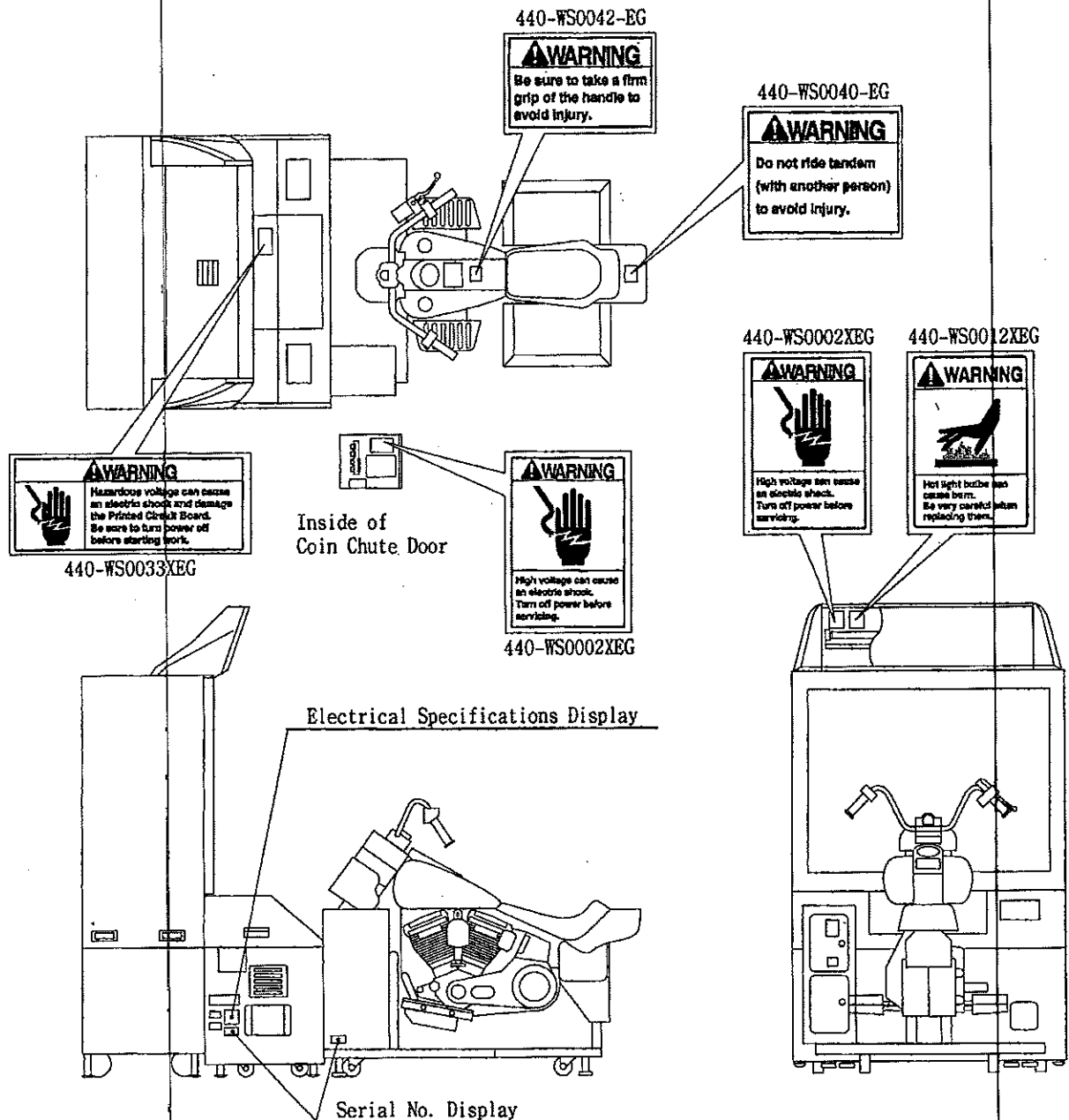

2. PRECAUTIONS CONCERNING INSTALLATION LOCATION



This product is to be used indoors. Do not install it outside. Even indoors, avoid installing in places mentioned below so as not to cause a fire, electric shock, injury and or malfunctioning.

- Places subject to rain or water leakage, or places subject to high humidity in the proximity of an indoor swimming pool and or shower, etc.
- Places subject to direct sunlight, or places subject to high temperatures in the proximity of heating units, etc.
- Places filled with inflammable gas or vicinity of highly inflammable/volatile chemicals or hazardous matter.
- Dusty places.
- Sloped surfaces.
- Places subject to any type of violent impact.
- Vicinity of anti-disaster facilities such as fire exits and fire extinguishers.
- The operating (ambient) temperature range is from 5°C to 40°C. Only in the case a projector is employed, the temperature range is from 5°C to 30°C.

LIMITATIONS OF USAGE REQUIREMENTS



- Be sure to check the Electrical Specifications. Ensure that this product is compatible with the location's power supply, voltage and frequency requirements. A plate describing Electrical Specifications is attached to the product. Non-compliance with the Electric Specifications can cause a fire and electric shock.
- This product requires the Breaker and Earth Mechanisms as part of the location facilities. Using them in a manner not independent can cause a fire and electric shock.
- Ensure that the indoor wiring for the power supply is rated at 10A or higher (AC single phase 100~120V), and 7A or higher (AC 220~240V). Non-compliance with the Electrical Specifications can cause a fire and electric shock.
- Be sure to independently use the power supply equipped with the Earth Leakage Breaker. Using a power supply without the Earth Leakage Breaker can cause an outbreak of fire when earth leakage occurs.
- Putting many loads on one electrical outlet can cause generation of heat and a fire resulting from overload.
- When using an extension cord, ensure that the cord is rated at 10A or higher (AC 100~120V area) and 7A or higher (AC 220~240V area). Using a cord rated lower than the specified rating can cause a fire and electric shock.



- Note that for transporting the machine into the location's building, the minimum necessary dimensions of the opening (of doors, etc.) are 1.1 m (W) and 1.2m(H).
- For the operation of this machine, secure a minimum area of 1.6m (W)× 2.6m (D).
- Provide sufficient space so as to allow this product's ventilation fan to function efficiently. To avoid machine malfunctioning, do not turn off power for the fan, or do not place any obstacles near the ventilation opening.

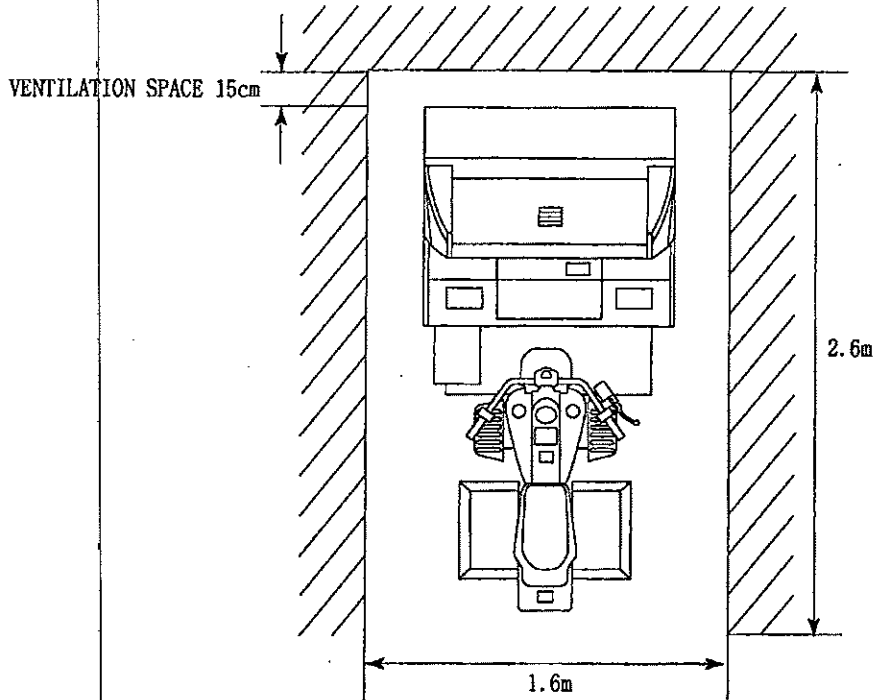

FIG. 2

Electric current consumption

MAX.	7.07 A	(AC 110V	50 Hz)
MAX.	6.89 A	(AC 110V	60 Hz)
MAX.	6.36 A	(AC 120V	60 Hz)
MAX.	3.53 A	(AC 220V	50 Hz)
MAX.	3.43 A	(AC 220V	60 Hz)
MAX.	3.37 A	(AC 230V	50 Hz)
MAX.	3.30 A	(AC 230V	60 Hz)
MAX.	3.21 A	(AC 240V	50 Hz)
MAX.	3.13 A	(AC 240V	60 Hz)
MAX.	7.0 A	(For TAIWAN)	

3. OPERATION

The bike body of the product banks left and right during game play. In order to prevent accidents, be sure to comply with the following points before and during operation.

PRECAUTIONS TO BE HEDED BEFORE STARTING THE OPERATION



In order to avoid accidents, check the following before starting the operation:

- Check if all of the adjusters are in contact with the surface. If they are not, the cabinet can move and cause an accident.
- Check the Safety Rubber of the bike body's front and rear portions for any damage or omission. An Irregular Safety Rubber can cause injury such as the customer's finger(s) being caught.

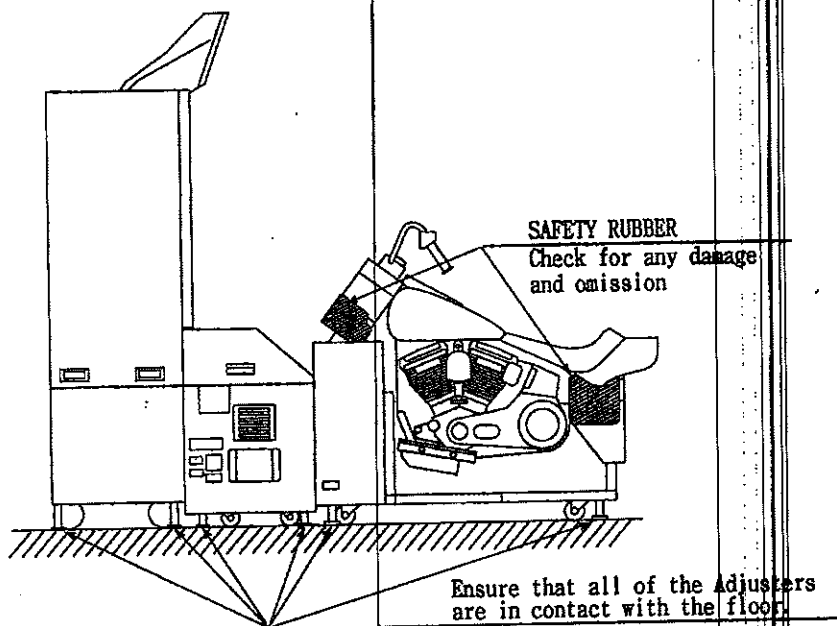

- Do not put any heavy item on this product. Placing any heavy item on the product can cause a falling down accident or parts damage.
- Do not climb on the product. Climbing on the product can cause falling down accidents. To check the top portion of the product, use a step.
- To avoid electric shock, check to see if door & cover parts are damaged or omitted.
- To avoid electric shock, short circuit and or parts damage, do not put the following items on or in the periphery of the product.
Flower vases, flowerpots, cups, water tanks, cosmetics, and receptacles/containers/vessels containing chemicals and water.



To prevent accidents, provide sufficient space for machine installation considering potentially crowded situation. Depending on the player's operation, the bike body banks left and right. If the installation space is limited, the bike can come into contact with and hit customers causing an accident or trouble.

PRECAUTIONS TO BE HEEDED DURING OPERATION

To avoid injury and trouble, be sure to constantly give careful attention to the behavior and manner of the visitors and players.



- To avoid injury and accidents, those who fall under the following categories are not allowed to play the game.
 - Intoxicated persons.
 - Pregnant women or those who are in the likelihood of pregnancy.
 - Those who need assistance such as the use of an apparatus when walking.
 - Those who have high blood pressure or a heart problem.
 - Those who have experienced muscle convulsion or loss of consciousness when playing video game, etc.
 - Persons susceptible to motion sickness.
 - Persons whose act runs counter to the product's warning displays.

- To avoid falling down accidents and injury, do not allow the player to ride if his feet can not be placed on the step when he is seated. To avoid an accident, instruct persons of short stature to refrain from playing the game.

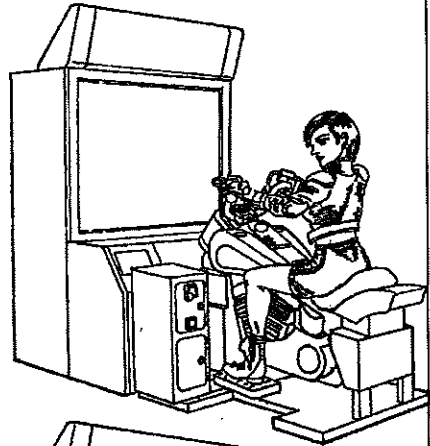

- To avoid injury and parts damage, instruct not to ride tandem (with another person).

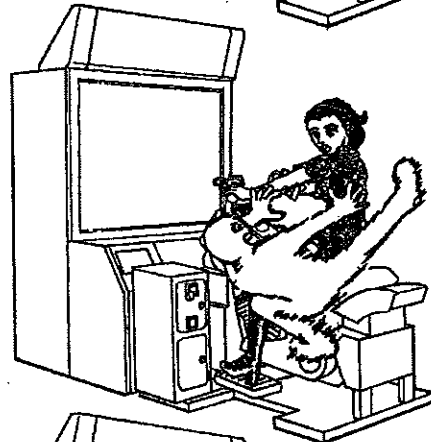

- Instruct those who wear high-heeled shoes to refrain from playing the game by explaining that playing game with high-heeled shoes is very likely to cause potentially hazardous situation.

- Ensure the player is seated appropriately by bestriding the seat. Since the motorcycle banks, riding sideways can cause violent falling down accidents.

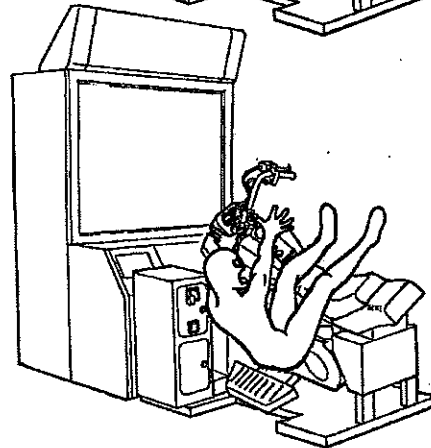



- To avoid injury resulting from falling down, and electric shock due to spilled drinks, instruct the player not to place heavy items or drinks on the product.
- To avoid electric shock and short circuit, do not allow customers to put hands and fingers or extraneous matter in the openings of the product or small openings in or around the doors.
- To avoid falling down and injury resulting from falling down, immediately stop the customer's leaning against or climbing on the product, etc.
- To avoid electric shock and short circuit, do not allow the customers to unplug the power plug without a justifiable reason.



- Although this product has the accident preventive covering attached to potentially hazardous places where hand and fingers could be caught, small children are unable to perceive hazards. Use care so that small children do not come close to the product when in play.

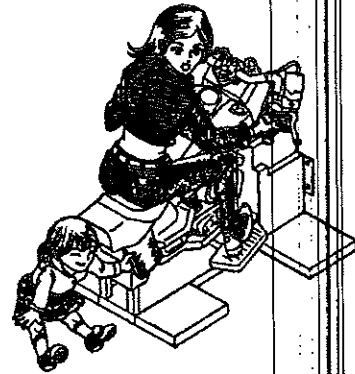

- Use care so that onlookers do not come close to the cabinet. Keep persons other than the player away from the motorcycle.

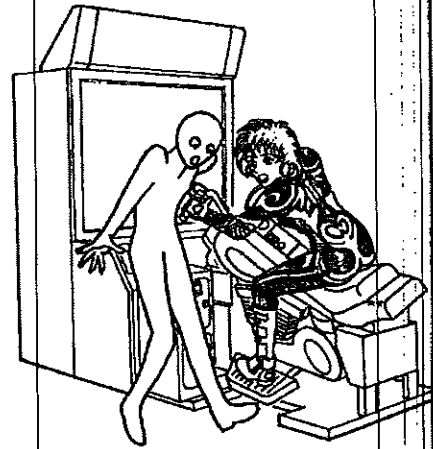

- To prevent accidents, instruct the player to take firm hold of the handlebar. To avoid injury, instruct the players to refrain from single-handed taking grip of the handle (which is very likely to cause potentially hazardous situation, should he attempt to do so).

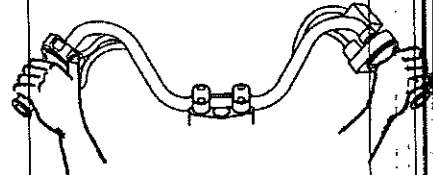

- Immediately stop such violent acts as hitting and kicking the product. Such violent acts can cause parts damage or falling down, resulting in injury due to fragments and falling down.

4. NAME OF PARTS

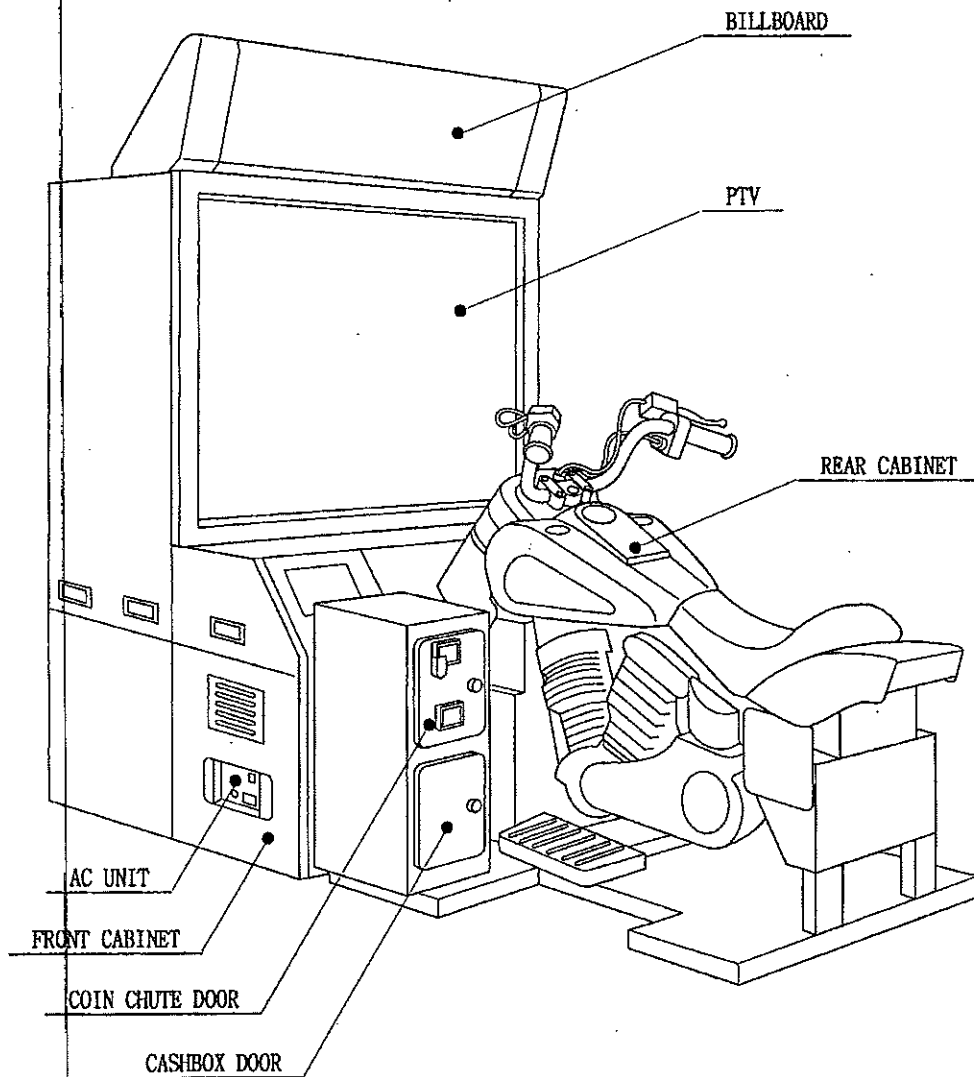

FIG. 4

TABLE 4

	Width × Length × Height	Weight
PTV	1,140mm (W) × 554mm (D) × 1,670mm (H)	TOSHIBA TYPE 93kg
		MITSUBISHI TYPE 91kg
BILLBOARD	1,140mm (W) × 454mm (D) × 296mm (H)	15kg
FRONT CABINET	1,140mm (W) × 500mm (D) × 754mm (H)	73kg
REAR CABINET	1,006mm (W) × 1,424mm (D) × 1,166mm (H)	161kg
When assembled	1,140mm (W) × 2,347mm (D) × 1,966mm (H)	Approx. 342kg

5. ACCESSORIES

When transporting the machine, make sure that the following parts are supplied.

TABLE 5 ACCESSORIES

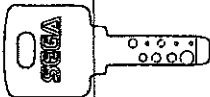
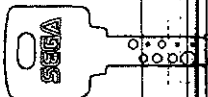
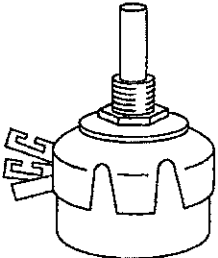
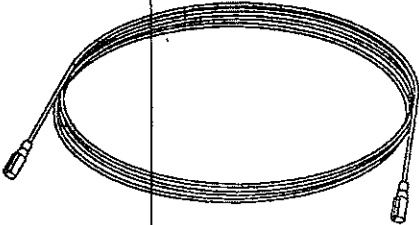
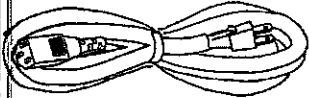
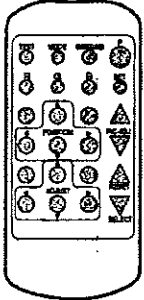
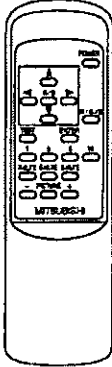
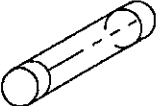
<p>DESCRIPTION Part No. (Qty.) Note: Figures If Part No. has no description, the Number has not been registered or can not be registered. Such a part may not be obtainable even if the customer desires to purchase it. Therefore, ensure that the part is in safekeeping with you.</p>	<p>OWNERS MANUAL 420-6365-01 (1)</p>	<p>KEY MASTER 220-5576 (2)</p>	<p>KEY (2)</p>
		<p>For opening/closing the doors</p>	<p>For the CASHBOX DOOR</p>
			
<p>VOL CONT B-5K OHM 220-5484 (1) For spare, refer to Section 10, 11.</p>	<p>ASSY FIBER CABLE 600-6275-0200 (3) For communications play, refer to Section 19.</p>		
			
<p>AC Cable (Power Cord) 600-8724 (1) : TAIWAN 600-8729 (1) : USA 600-8695 (1) : USA 600-8695-01 (1) : USA 600-8618 (1) : OTHERS Used for installation, see [A] of Section 6.</p>	<p>TOSHIBA Remote Control for Projector Used for adjustment. See Sec. 13. 200-5536(1)</p>	<p>MITSUBISHI Remote Control for Projector Used for adjustment. See Sec. 13. 200-5532(1)</p>	
			
<p>FUSE 7000mA 125V 514-5036-7000 (1) For spare, refer to Section 16.</p>	<p>One of the above 2 types of Remote Controls is used for the Projector.</p>		
			

CARTON BOX
601-8928 (1)
Used for transporting
the Game Board.
Refer to the following.

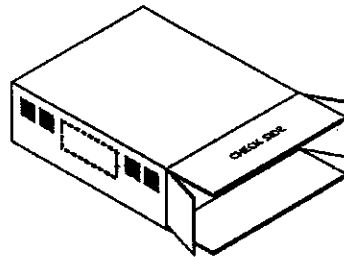

HOW TO USE THE CARTON BOX



- When asking for the replacement or repair of the product's Game Board (MODEL 3 BOARD), be sure to put the Game Board together with the Shield Case in the Carton Box. Otherwise, the request is not acceptable.
- Put the Shield Case in the Carton Box by paying attention to the correct direction as per the following instructions and as shown by the instructions printed on the Carton Box. Handling in an erroneous manner can damage the Game Board.

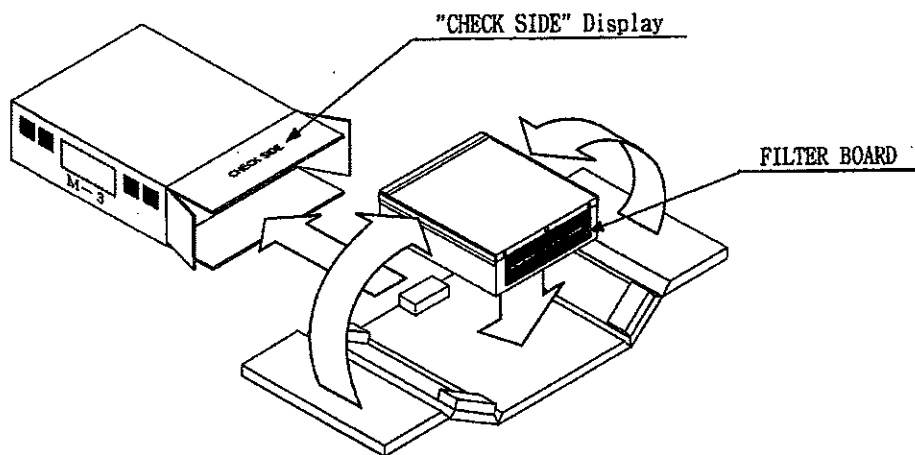

Wrap the Shield Case with the packing material and put it in the Carton Box as shown. Putting it upside down or packing otherwise in the manner not shown can damage the Game Board and parts.

6. ASSEMBLING AND PRECAUTIONS



- Perform the assembly work by following the procedure herein stated. Failing to comply with the instructions can cause an electric shock.
- Assembling should be performed as per this manual. Since this is a complex machine, erroneous assembling can cause an electric shock or damage to the machine resulting in not functioning as per specified performance.
- When assembling, be sure to perform the work by plural persons. Depending on the assembly work, there are some cases in which performing the work by a single person can cause personal injury or parts damage.

When carrying out the assembly work, follow the procedure in the following 5-item sequence:

- 1** ASSEMBLING THE PTV
- 2** ASSEMBLING THE CABINET
- 3** SECURING IN PLACE (ADJUSTER ADJUSTMENT)
- 4** POWER SUPPLY, AND EARTH CONNECTION
- 5** ASSEMBLY CHECK

When assembling, make sure that tools such as a Phillips type screwdriver, wrench (for M16 hexagon bolt), and socket wrench (M8 hexagon bolt and nut) are available.

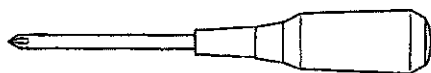

Phillips type screwdriver

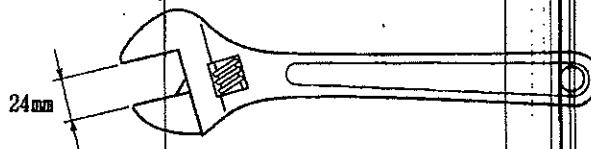

WRENCH (for M16 hexagon bolt)

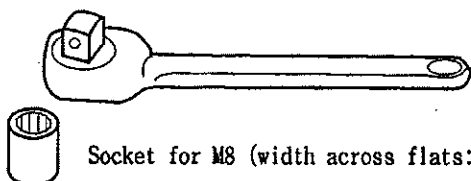

Socket for M8 (width across flats: 13 mm)

SOCKET WRENCH

1

ASSEMBLING THE PTV



WARNING!

Installing the Billboard by one person is difficult. Be sure to use plural persons to perform work safely and accurately.



CAUTION!

To perform work safely and securely, be sure to prepare a step which is in a secure and stable condition. Working without using a step can cause a violent falling down accidents.

- ① By using the specified screws, secure the 2 Mask Holders to the top of Projection Display.
- ② Insert the TV Mask from the underside as shown and secure with a total of 6 screws.
- ③ 2 Side Brackets to the front of Projection Display in the installation direction shown with 2 screws for each. (FIG. 6. 1a)
- ④ While supporting the Billboard by 2 persons, another person using the step is to insert the Billboard Connector into the Terminal Board on top of Projection Display. (FIG. 6. 1b)
- ⑤ Insert the Billboard from the rear to the screen side as shown and secure with 2 screws (FIG. 6. 1a)

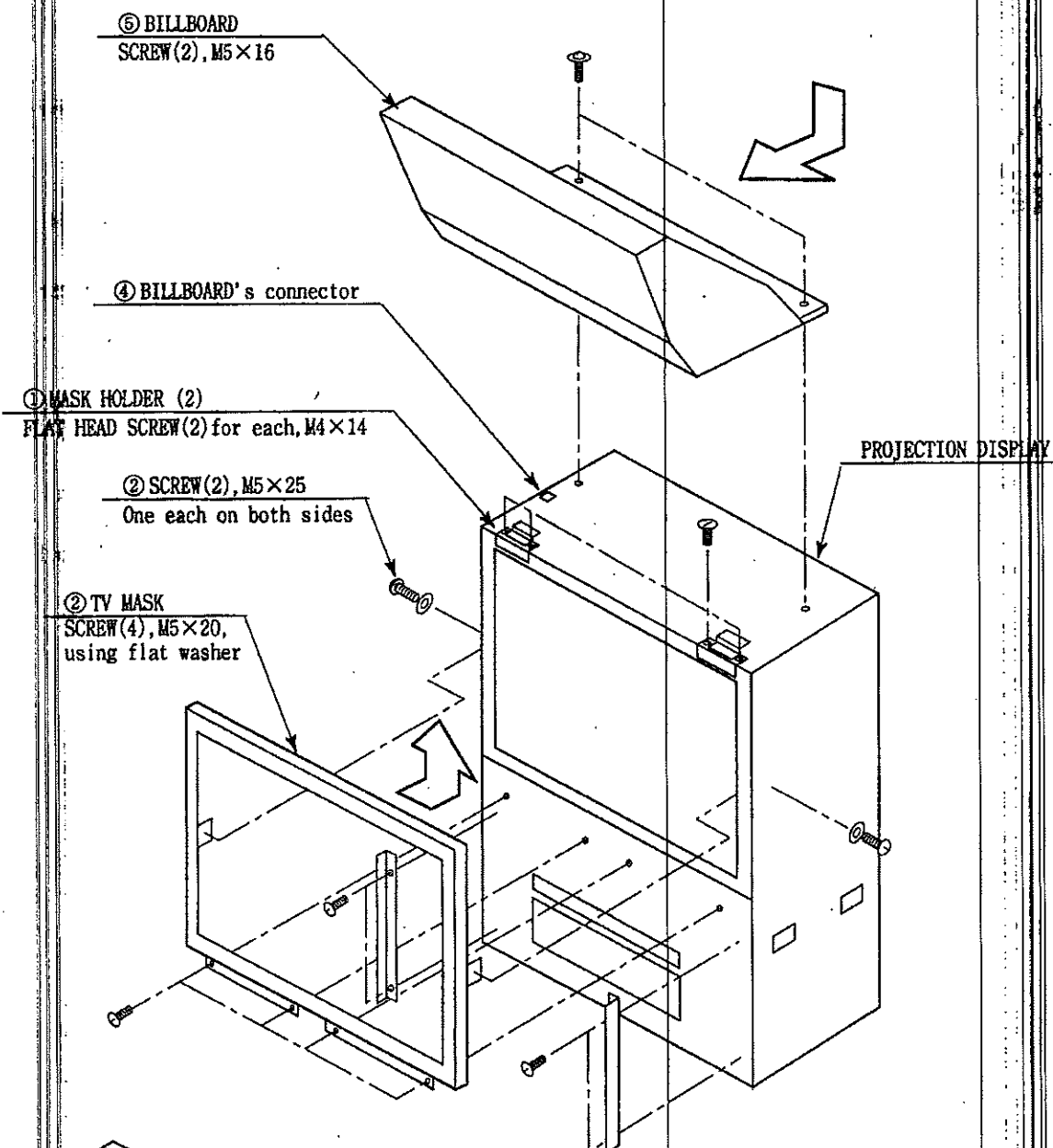

FIG. 6. 1a

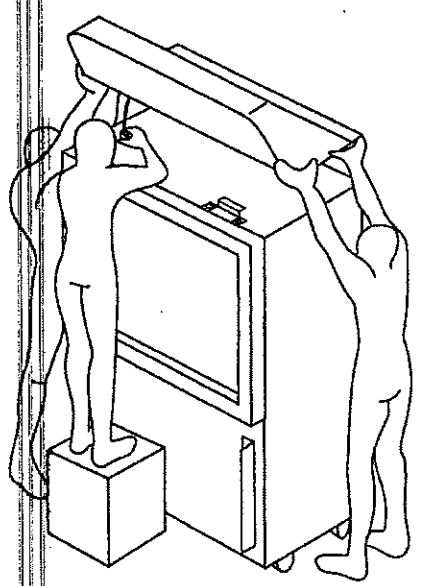

FIG. 6. 1b

2

ASSEMBLING THE CABINET



- Ensure that connectors are accurately connected. Incomplete connections can cause electric shock.
- Be careful so as not to damage wirings. Damaged wiring can cause an electric shock and short circuit.

- ① By utilizing the 2 wires of the Front Cabinet, make wiring connection between the PTV and the Front Cabinet. One of the 2 wires has 4 connectors. Insert the wiring connectors each of which wire covering is red, green, and blue to the corresponding one of R. G. B. terminals as per connector panel display inside the PTV, and insert the remaining wire connector to the SYNC terminal (FIG. 6. 2 a).

The Connector's insertion angle is predetermined. Inserting the Connector in a forcible manner will damage the Connector. Check for the correct inserting direction and then insert the Connector. After the insertion of Connector, turn the Connector's Ring to the right to lock the connection.

mitsubishi PTV

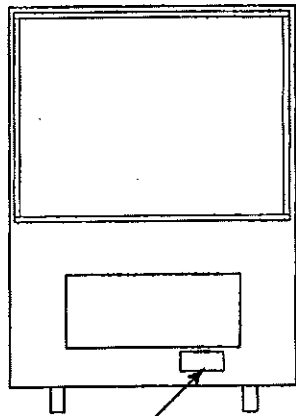

CONNECTOR PANEL

TOSHIBA PTV

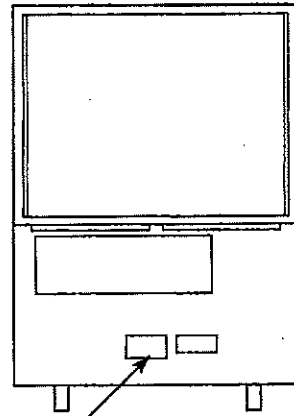

CONNECTOR PANEL

Depending on the Projector, the connector panel position varies.

FIG. 6. 2 a

- ② The PTV connector panel has 3p white connector in addition to the Connectors displayed as R. G. B. and SYNC. Connect the remaining wire, which comes from the Front Cabinet, to the 3p white connector.
- ③ Tightly join the PTV and the Front Cabinet by using care so as not to damage the wiring.
- ④ Connect the PTV and the Front Cabinet with the 4 screws. (FIG. 6. 2 b)
- ⑤ Make wiring connection between the Front Cabinet and Rear Cabinet. Connect a total of 3 connectors.
- ⑥ Remove the screw which secures the earth wire inside the rear cabinet, fasten the terminal of the earth wire which comes from the Front Cabinet together with the terminal of the earth wire inside the rear cabinet to the screw by using the previously removed screw.
- ⑦ By using care so as not to damage the wiring, tightly join the Front and Rear cabinets together.
- ⑧ Secure both cabinets with 4 hexagon bolts.

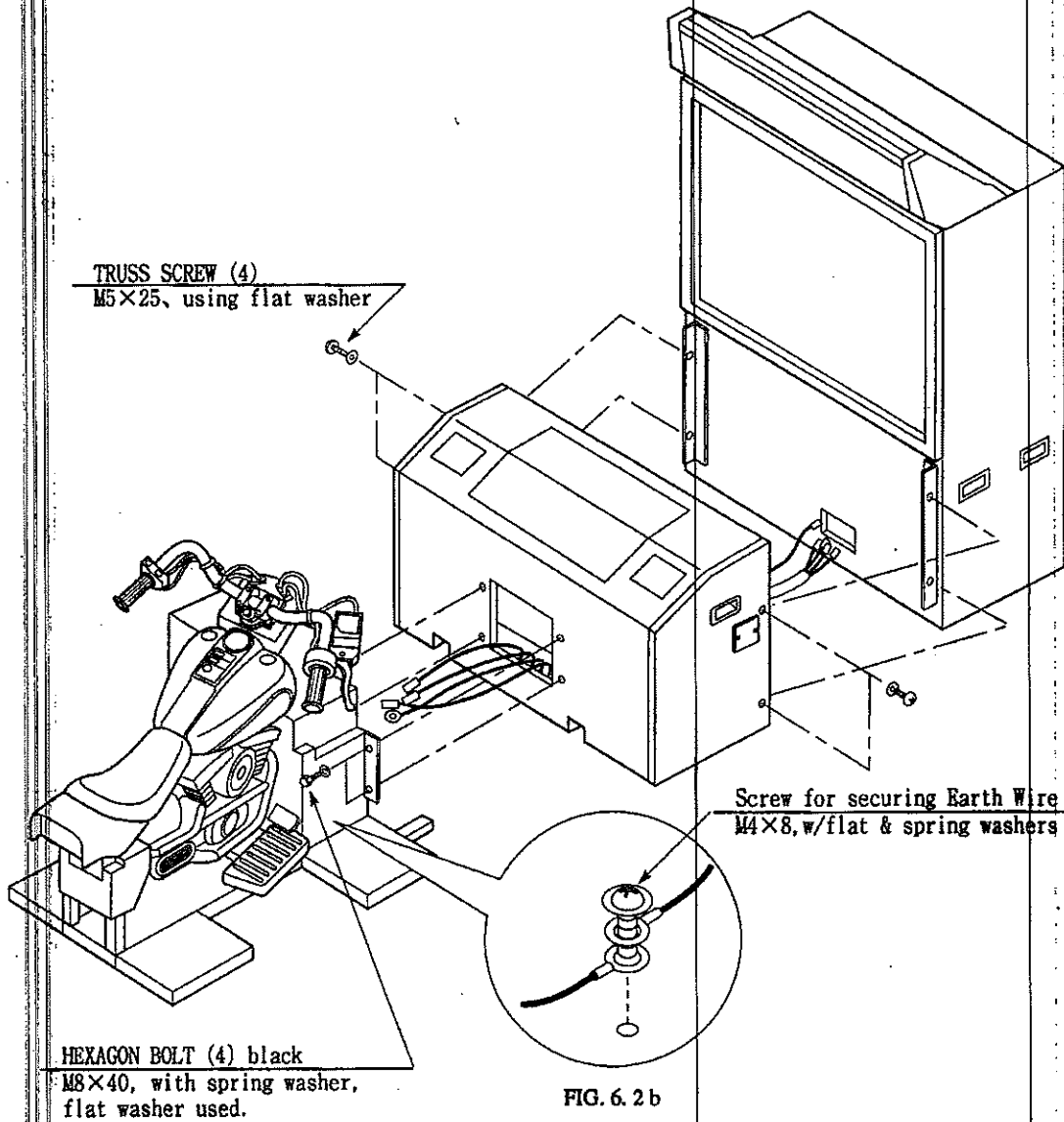

FIG. 6. 2 b

3 SECURING IN PLACE (ADJUSTER ADJUSTMENT)



Make sure that all of the adjusters are in contact with the floor. If they are not, the cabinet may move causing an accident.

This machine has 12 casters (4 for the PTV, 4 for the Front Cabinet, 4 for the Rear Cabinet) and 12 adjusters (4 for the PTV, 4 for the Front Cabinet, 4 for the Rear Cabinet). (FIG. 6. 3a)
 When the installation position is determined, cause the adjusters to come into contact with the floor directly, make adjustments in a manner so that the casters will be raised approximately 5mm. from the floor and make sure that the machine position is level.

- ① Move the machine to the installation position. When installing the machine close to a wall, be sure to secure passage space to enable the player to get in the machine.
- ② Cause all of the adjusters to make contact with the floor. By using a wrench, make adjustments in the height of the adjusters to ensure that the machine's position is level.
- ③ After making adjustments, fasten the adjuster nut upward and secure the height of the adjuster. (FIG. 6. 3 b)

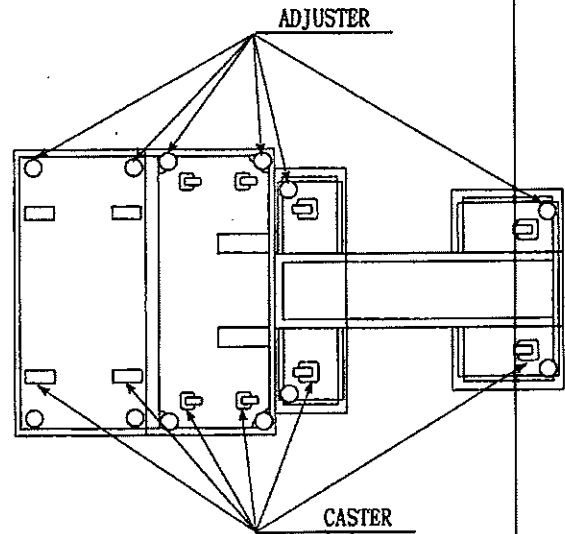

FIG. 6. 3 a BOTTOM VIEW

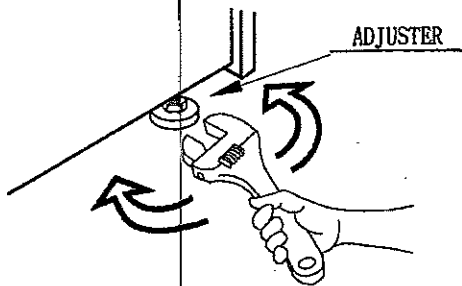

FIG. 6. 3 b ADJUSTER

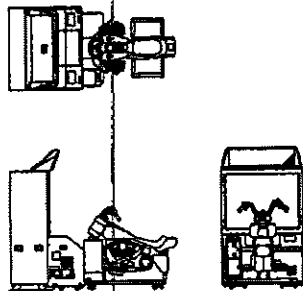
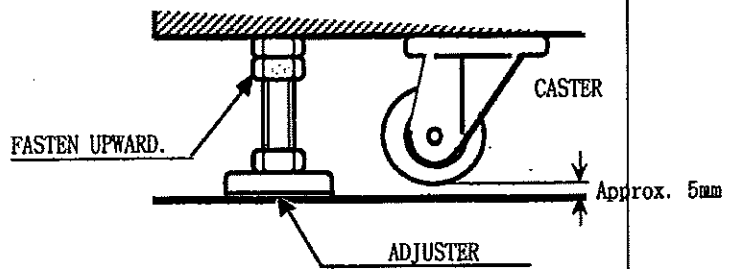

FIG. 6. 3 c
 Refer to this Fig. (Scale:1/100)
 for the layout of the place of
 installation.

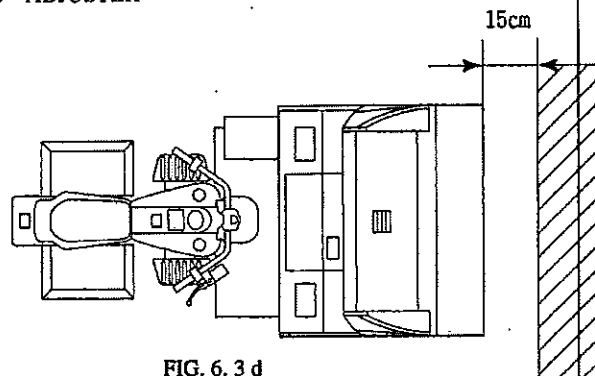

FIG. 6. 3 d
 Provide sufficient space so as to
 allow for ventilation by the
 ventilation fan.

4

POWER SUPPLY, AND EARTH CONNECTION



- Be sure to independently use the power supply socket outlet equipped with an Earth Leakage Breaker. Using a power supply without an Earth Leakage Breaker can cause a fire when the leakage occurs.
- Ensure that the "accurately grounded indoor earth terminal" and the earth wire cable are available (except in the case where a power cord plug with earth is used). This product is equipped with the earth terminal. Connect the earth terminal and the indoor earth terminal with the prepared cable. If the grounding work is not performed appropriately, customers can be subjected to an electric shock, and the product's functioning may not be stable.
- Ensure that the power cord and earth wire are not exposed on the surface (passage, etc.). If exposed, they can be caught and are susceptible to damage. If damaged, the cord and wire can cause an electric shock and short circuit accidents. Ensure that the wiring position is not in the customer's passage way or the wiring has protective covering.

- ① The AC unit is mounted on the side of Front Cabinet. The AC Unit incorporates the Main SW, Earth Terminal and the Inlet which connects the Power Cord. Firmly insert the Power Plug into the Plug Socket and the other side of the plug to the Inlet. Turn the Main SW ON to turn power ON.
- ② Ensure that the Main SW is OFF.

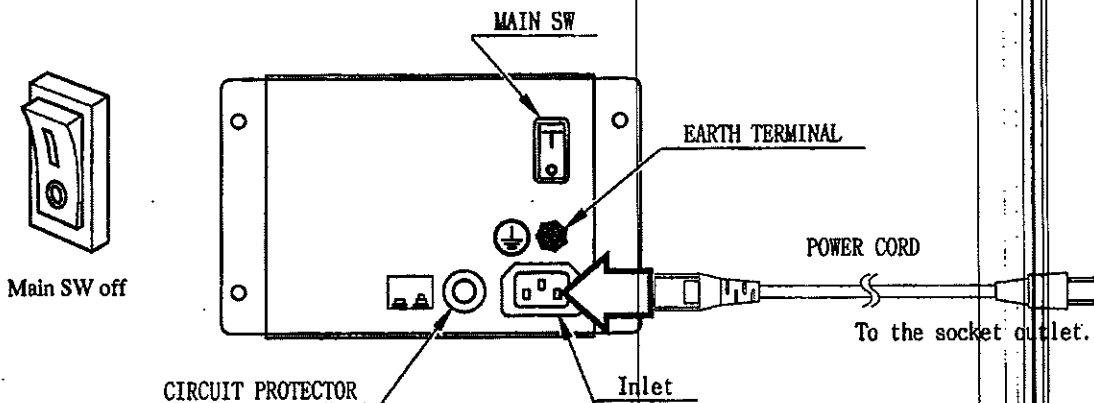

FIG. 6.4 a AC UNIT

- ③ Connect one end of the earth wire to the AC Unit earth terminal, and the other end to the indoor earth terminal. The AC Unit earth terminal has a Bolt and Nut combination. Take off the Nut, pass the end of earth wire through the Bolt, and fasten the Nut.

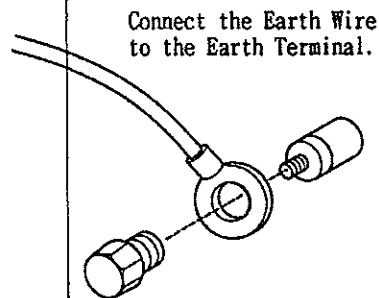

FIG. 6.4 b Earth Wire Connection

- ④ Firmly insert the power cord into the plug socket and inlet.
- ⑤ Perform wiring for the Power Cord and Earth Wire. Install protective covering for the Power Cord and Earth Wire.

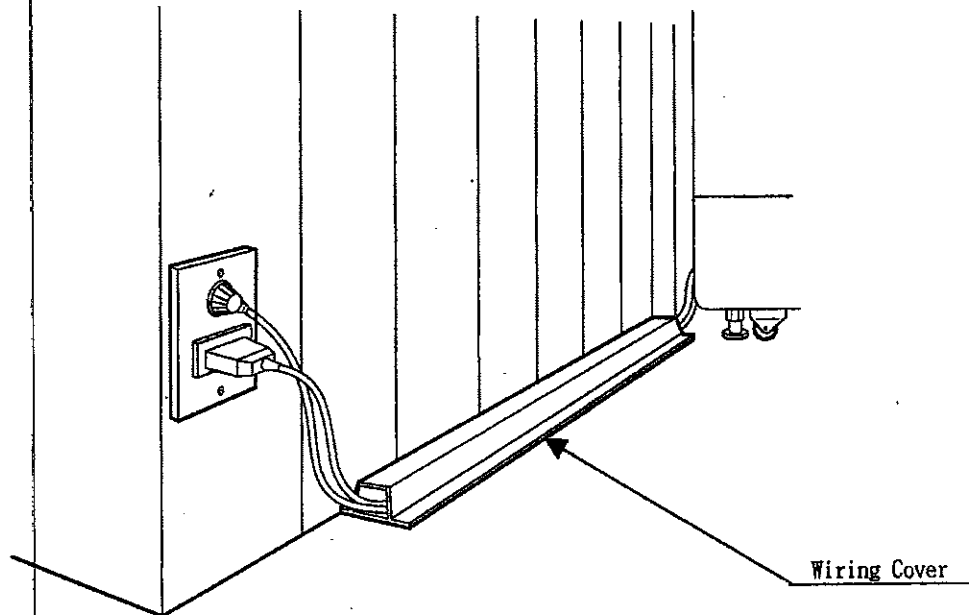

FIG. 6. 4 c Connecting Power Cord and Earth Wire

5**ASSEMBLY CHECK**

In the TEST MODE, ascertain that the assembly has been made correctly and IC BD. is satisfactory (refer to Section 9).

In the test mode, perform the following test:

(1) MEMORY TEST

CPU ROM TEST			
GOOD (CROM03 MASK) IC. 1			
GOOD (CROM02 MASK) IC. 2			
GOOD (CROM01 MASK) IC. 3			
GOOD (CROM00 MASK) IC. 4			
GOOD (CROM13 MASK) IC. 5			
GOOD (CROM12 MASK) IC. 6			
GOOD (CROM11 MASK) IC. 7			
GOOD (CROM10 MASK) IC. 8			
GOOD (CROM33 EPROM) IC. 13			
GOOD (CROM32 EPROM) IC. 14			
GOOD (CROM31 EPROM) IC. 15			
GOOD (CROM30 EPROM) IC. 16			
GOOD (CROM3 EPROM) IC. 17			
GOOD (CROM2 EPROM) IC. 18			
GOOD (CROM1 EPROM) IC. 19			
GOOD (CROM0 EPROM) IC. 20			

PRESS SERVICE BUTTON TO CONTINUE

Selecting the MEMORY TEST on the test mode menu screen causes the on-board memory to be tested automatically. The game board is satisfactory if the display beside each IC No. shows GOOD.

(2) INPUT TEST

INPUT TEST	
HANDLEBAR	80
THROTTLE	00
FRONT BRAKE	00
REAR BRAKE	00
VIEW CHANGE	OFF
MUSIC SELECT	OFF
SHIFT UP	OFF
SHIFT DOWN	OFF
START	OFF
COIN #1	OFF
COIN #2	OFF
SERVICE-SW	OFF
TEST-SW	OFF

PRESS SERVICE+TEST BUTTON TO EXIT

Selecting the INPUT TEST on the test mode menu screen causes the screen (on which each switch and V. R. are tested) to be displayed. Press each switch. For the coin switch test, insert a coin from the coin inlet with the coin chute door being open. If the display beside each switch indicates "ON," the switch and wiring connections are satisfactory. Check the display of V. R. value for the handlebar and accelerator & brake. If the V. R. values are not satisfactory, refer to Sections 10 & 11.

(3) OUTPUT TEST

OUTPUT TEST			
START	LAMP	OFF	
VIEW CHANGE	LAMP	OFF	
MUSIC SELECT	LAMP	OFF	
CABINET LOCK		OFF	

-EXIT

SELECT WITH SERVICE BUTTON
AND PRESS TEST BUTTON

In the output test mode, carry out lamp test to ensure that each lamp lights up satisfactorily.

(4) SOUND TEST

SOUND TEST	
No. 0	
SELECT WITH SERVICE BUTTON	
PRESS TEST BUTTON TO EXIT	

In the TEST mode, selecting SOUND TEST causes the screen (on which sound related BD and wiring connections are tested) to be displayed. Be sure to check if the sound is satisfactorily emitted from each speaker and the sound volume is appropriate.

(5) C.R.T. TEST

C.R.T. TEST PAGE 1/2	
0	31
	RED
	GREEN
	BLUE
	WHITE
PRESS TEST BUTTON TO CONTINUE	

In the TEST mode menu, selecting C.R.T. TEST allows the screen (on which the monitor is tested) to be displayed. Although the monitor adjustments have been made at the time of shipment from the factory, make judgment as to whether an adjustment is needed by watching the test mode screen. If it is necessary, adjust the monitor by referring to Section 13.

C.R.T. TEST PAGE 2/2	
[Grid]	
PRESS TEST BUTTON TO EXIT	

Perform the above inspections also at the time of monthly inspection.

7. PRECAUTIONS TO BE HEEDED WHEN MOVING THE MACHINE



- When moving the machine, be sure to pull out the plug from the power supply. Moving the machine with the plug as is inserted can cause the power cord to be damaged, resulting in a fire and or electric shock.
- When moving the machine on the floor, retract the Leg Adjusters and ensure that Casters make contact with the floor. During transportation, pay careful attention so that Casters do not tread power cords and earth wires. Damaging the power cords can cause an electric shock and or short circuit.
- When lifting the cabinet, be sure to hold the catch portions or bottom part. Lifting the cabinet by holding other portions can damage parts and installation portions due to the empty weight of the cabinet, and cause personal injury.
- When moving the PTV, do not push it from the rear side. Push it from sideways. Pushing the PTV from the rear side can have the PTV fall down, causing personal injury etc. In case the floor has slanted surfaces or step-like differences, be sure to move the machine by 2 or more persons.



When moving the machine on the floor with slanted surfaces or step-like differences, ensure that the PTV, Front Cabinet and Rear Cabinet are separated. Lifting the Cabinet with those items as is joined can cause the joint portions to be damaged.

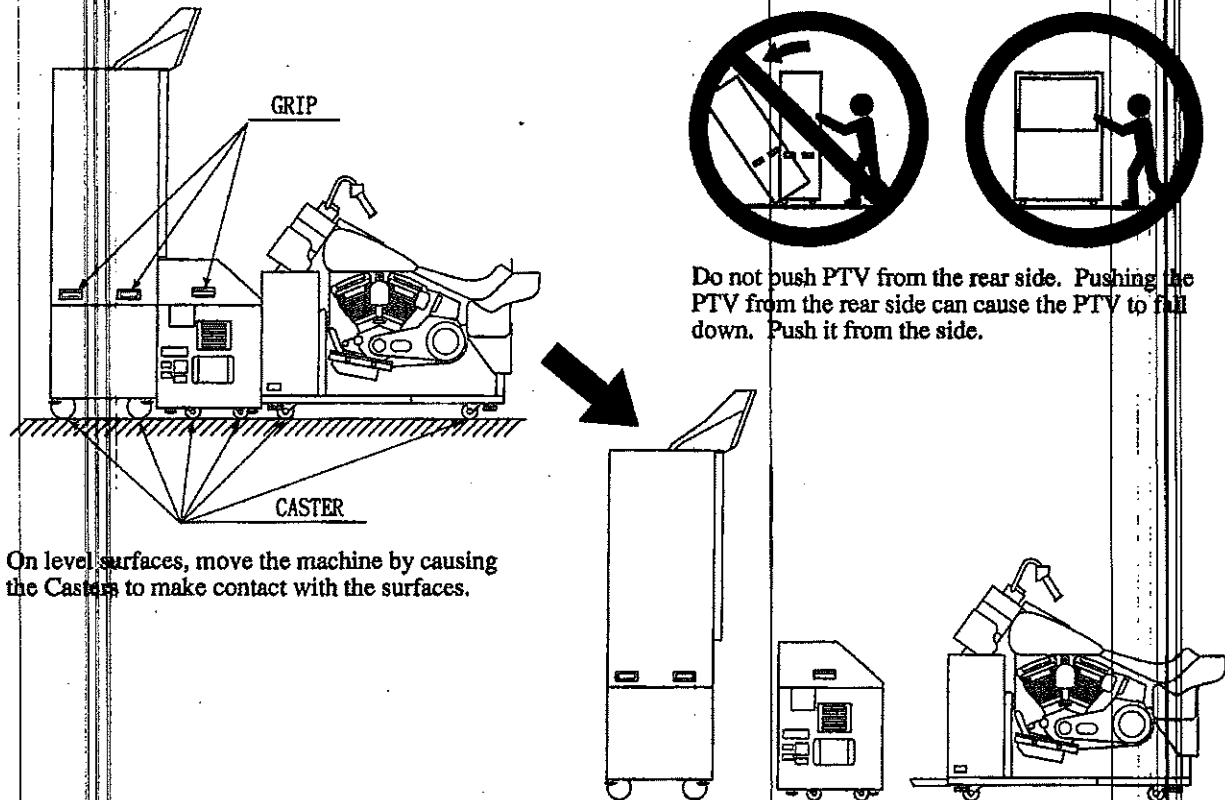

On level surfaces, move the machine by causing the Casters to make contact with the surfaces.

Do not push PTV from the rear side. Pushing the PTV from the rear side can cause the PTV to fall down. Push it from the side.

FIG. 7

Where there are steps (or step-like differences in grade), move the machine by separating into each unit.

8. CONTENTS OF GAME

The following are operations and responses obtained when the machine functions satisfactorily. Any functioning different from the following may have been caused by a certain fault. Immediately investigate and eliminate the cause of malfunctioning to ensure satisfactory operation. The explanations herein mainly refer to the case where the game machine is used independently. In the communication play, some points may differ from the following explanations.

When energized, the Billboard's fluorescent lamp is always lit.

During ADVERTISE (in the status a coin(s) is not inserted), the contents of game and HOW TO PLAY, etc., are audio-visually explained. Note 1

The status of the on-tank 3 buttons will change to and from lighting up / flashing / Lights-out.

Although the Start button is unlit during ADVERTISE, it blinks if even one coin is inserted, and is always lit during game play.

The View Change button and Music Select button are unlit during ADVERTISE and lit when the Select mode is displayed. During game, these flash alternately.

During ADVERTISE, the Handlebar and Bike Body are locked and do not move.

- ① Be seated.
- ② Insert a coin(s). When one play worth of coin(s) is inserted, the Select mode appears.

At the same time the Select mode appears, the Handlebar and Bike Body are unlocked.

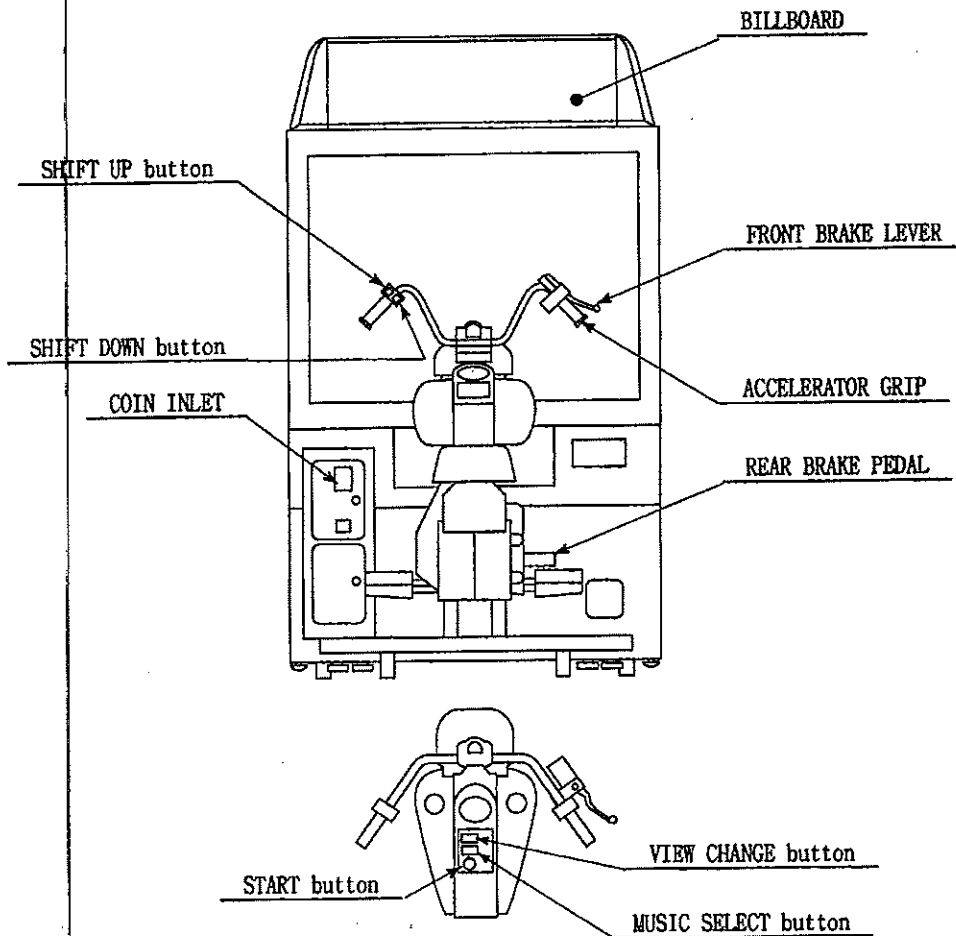

- ③ Select in order of BIKE and TRANSMISSION. Turn the handlebar to select and turn the ACCELERATOR GRIP to decide. Note 2

When the Select mode is displayed, countdown starts. At count 0, BIKE and TRANSMISSION being selected are automatically decided.

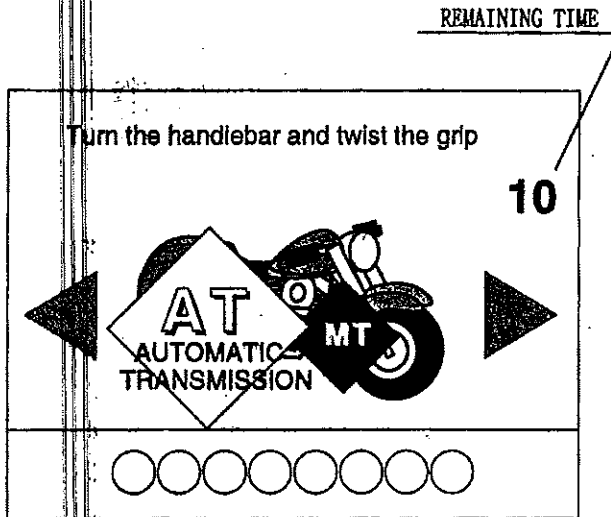

BIKE SELECT

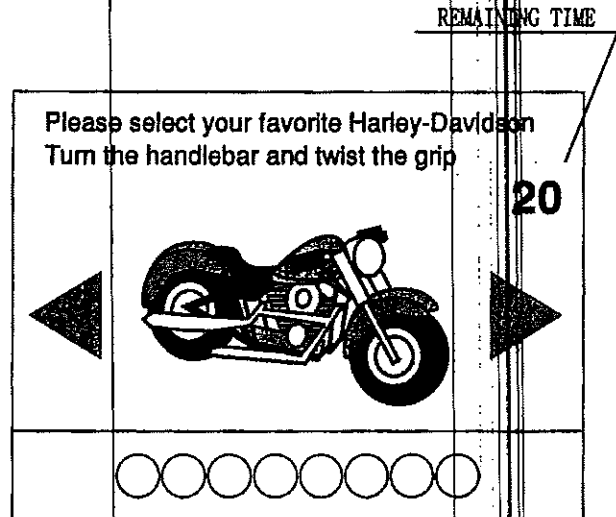

TRANSMISSION SELECT

- ④ When TRANSMISSION is decided, the race starts. The checkpoint (destination) is displayed on the screen, and Time Limit countdown starts. By turning the handlebar, the bike body banks. At the same time the race starts, the View Change button and Music Select button alternately light up / light out. Pressing the View Change button changes the View point in the game mode. Pressing the Music Select button changes the BGM (background music).

- ⑤ The distance to the checkpoint is displayed on the upper left section of the screen. The remaining time is indicated on the upper center, score points on the upper right, navigation window (map) on the lower left, and speedometer on the lower right.

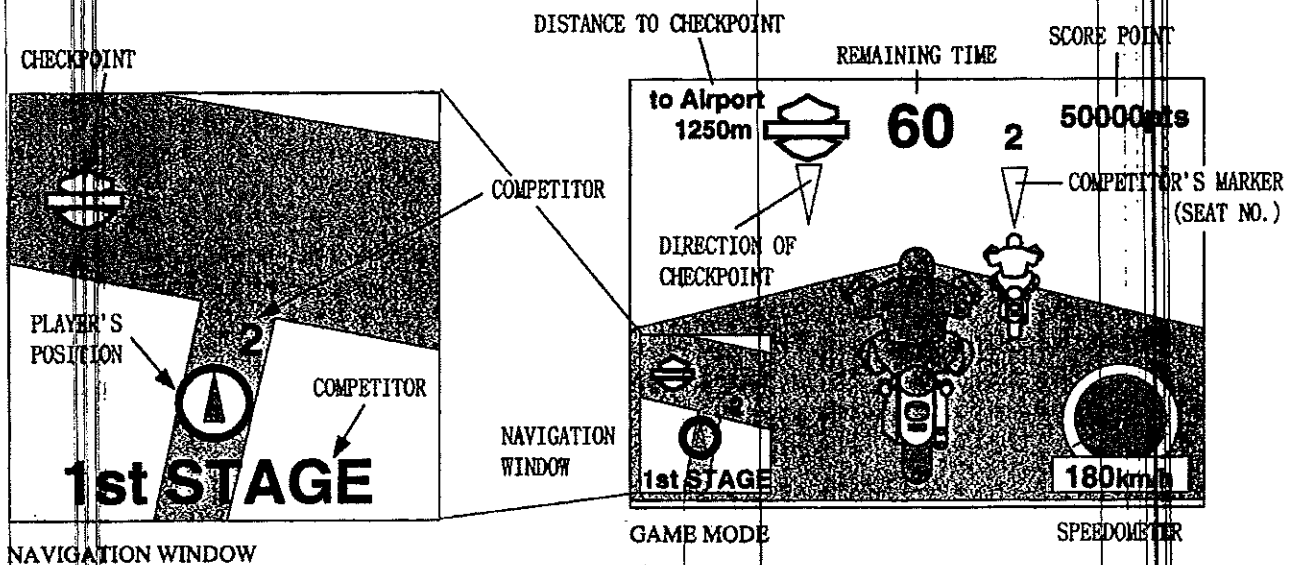

NAVIGATION WINDOW

GAME MODE

SPEEDOMETER

In the Specifications for USA, the distance to a checkpoint is displayed in feet and the Speedometer indicates MPH.

- ⑥ Run towards the checkpoint by judging the route from the arrow and NAVIGATION WINDOW. Passing the checkpoint within the time limit results in a Stage Clear. The time limit is extended and the next checkpoint is displayed.
- ⑦ If the player fails to pass the checkpoint within the time limit, the game is over.
- ⑧ Passing all of the checkpoints results in a Game Clear. Note 3 The successful player can see the ending mode.
- ⑨ After a game over, the accomplishment results are displayed on the map.
- ⑩ If the player scores high points, the Name Entry mode appears. Turn the handlebar, select character, and turn the Accelerator Grip to register the initial, etc.

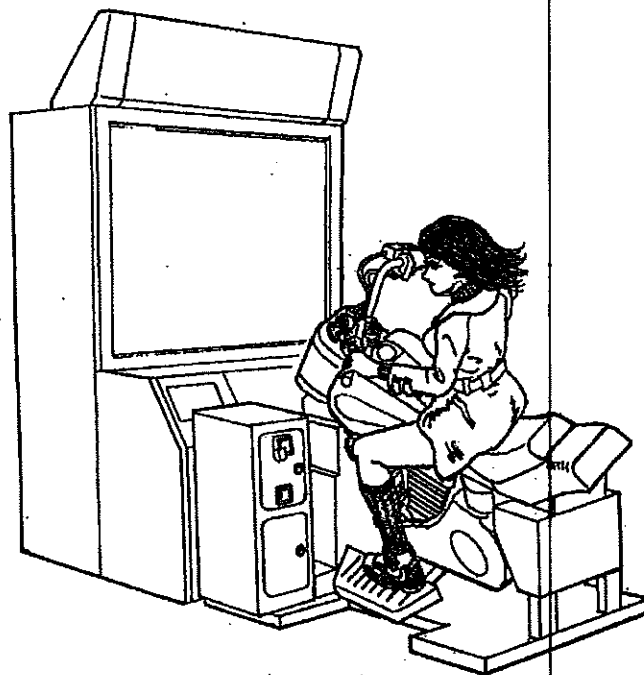

By turning the handlebar, the Bike Body banks.

- ⑪ When the game is over, or when you proceeded to the Name Entry mode, after determining the entry characters, return the handlebar to the front direction and have the bike body stand upright to cause locking to be applied. Even in the ADVERTISE mode, the bike body will not be locked in an as is banked status.

Note 1: Setting change can be made to no sound output during ADVERTISE.

Note 2: In the case where several machines are linked for communication play, the bike appearing first in the Select mode is predetermined by the ID number of each cabinet set for the communication play.

Note 3: The setting of the number of checkpoints required for game clear is changeable.

KNACK OF GAME PLAY

- To make full use of bike characteristics.

Each of the 5 types of bike has specific characteristic. High points can be earned by fully utilizing the bike characteristics and selecting the type which suites best for the player.

- To memorize the courses.

The player will surely accomplish a game clear by selecting the course on which he can make full use of the bike characteristics instead of overly relying on the map and arrow.

9. EXPLANATION OF TEST AND DATA DISPLAY

By operating the switch unit, periodically perform the tests and data check. When installing the machine initially or collecting cash, or when the machine does not function correctly, perform checking in accordance with the explanations given in this section. The following shows tests and modes that should be utilized as applicable.



When you enter the test mode, the Handlebar and Bike Body are unlocked. Do not lean against the Bike Body when you press the test button. Failure to observe this can cause violent falling down accidents as the Bike Body will bank. When you finish the test mode, the Handlebar and Bike Body will be locked.



CAUTIONS TO BE HEEDED WHEN USING THE TEST MODE:

- In the case where plural machines are linked for communication play, if even one seat enters the test mode, all of the linked seats also enter the test mode. Therefore, if any one of the linked machines is in play, use care so as not to use the test mode.
- The contents of the setting changes made will not be effective unless the test mode is finished in the test mode. When the setting is changed, be sure to "EXIT" in the menu mode.
- Do not press the Test button during network check at the time of turning power on or exiting from the test mode. If any one of the linked machines uses the test mode during network check, all other Seats will continue network checking. Cause all of the Seats to reenter the test mode and then have all of the Seats exit from the test mode simultaneously.

TABLE 9. EXPLANATION OF TEST MODE

ITEMS	DESCRIPTION	REFERENCE SECTIONS
INSTALLATION OF MACHINE	When the machine is installed, perform the following: 1. Check to see that each setting is as per standard setting made at the time of shipment. 2. In the INPUT TEST mode, check each SW and VR. 3. In the OUTPUT TEST mode, check each of lamps. 4. In the SELF-TEST mode, check ICs on the IC Board. 5. Set the present time.	9-9, 9-10 9-5 9-6 9-3, 9-4 9-13
MEMORY	Choose MEMORY TEST in the MENU mode to allow the MEMORY test to be performed. In this test, PROGRAM RAMs, ROMs, and ICs on the IC Board are checked.	9-3, 9-4
PERIODIC SERVICING	Periodically perform the following: 1. MEMORY TEST 2. Ascertain each setting. 3. In the INPUT TEST mode, test the CONTROL device 4. In the OUTPUT TEST mode, check each of lamps.	9-3, 9-4 9-9, 9-10, 9-13 9-5 9-6
CONTROL SYSTEM	1. In the INPUT TEST mode, check each SW and VR. 2. Adjust or replace each SW and VR. 3. If the problem can not be solved yet, check the CONTROL's moves.	9-5 10, 11
MONITOR	In the MONITOR ADJUSTMENT mode, check to see if the PROJECTOR adjustment is appropriately made.	9-8 13
IC BOARD	1. MEMORY TEST 2. In the SOUND TEST mode, check the sound related ROMs.	9-3, 9-4 9-7
DATA CHECK	Check such data as game play time and histogram to adjust the difficulty level, etc.	9-14

9-1 SWITCH UNIT AND COIN METER

STOP
IMPORTANT!

- Adjust to the optimum sound volume by considering the environmental requirements of the installation location.
- If the COIN METER and the game board are electrically disconnected, game play is not possible.

SWITCH UNIT

Open the coin chute door, and the switch unit shown will appear. The functioning of each SW is as follows:

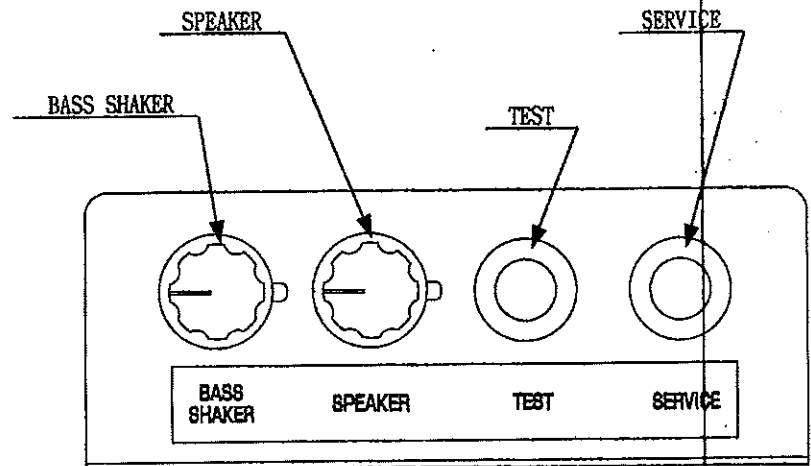

FIG. 9.1 a SWITCH UNIT

TEST BUTTON:
TEST

For the handling of the test button, refer to the following pages.

SERVICE BUTTON:
SERVICE

Gives credits without registering on the coin meter.

BASS SHAKER:
BASS SHAKER

Adjusts the output of the Handlebar's and under-the-seat Vibration Device.

SPEAKER:
SPEAKER

Adjusts sound volume of the Front Cabinet's left/right Speakers and the internal Woofer.

COIN METER

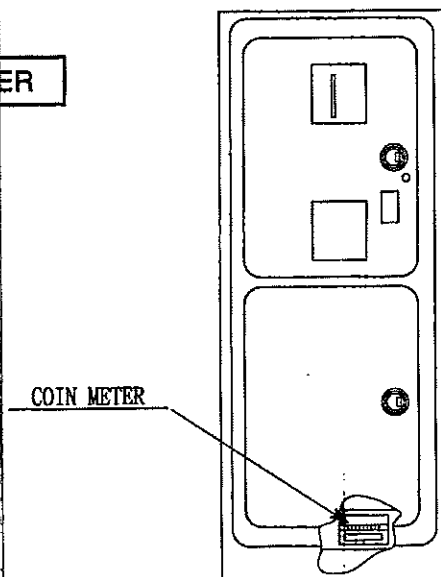

Open the Cashbox Door by using the key to have the Coin Meter appear underneath the Cashbox.

FIG. 9.1 b

9-2 TEST MODE

The test menu mainly allows the board to be checked for accurate functioning, coin assignments to be set, and also the monitor to be checked.

USING THE TEST MODE

```
TEST MENU
MEMORY TEST
BOUNDARY SCAN TEST
INPUT TEST
OUTPUT TEST
SOUND TEST
C. R. T. TEST
GAME ASSIGNMENTS
COIN ASSIGNMENTS
NETWORK ASSIGNMENTS
VOLUME ADJUSTMENTS
REAL TIME CLOCK TEST
BOOKKEEPING
BACKUP DATA CLEAR
EXIT

SELECT WITH SERVICE BUTTON
AND PRESS TEST BUTTON
```

FIG. 9.2 Menu Mode

In the test mode, the following buttons can also be used for operation.

SHIFT UP & VIEW CHANGE buttons:

To move → upward.

SHIFT DOWN & VIEW CHANGE buttons:

To move → downward.

START button:

The selected item's execution and OK.

- ① Press the test button to display the test item menu.
- ② Press the Service button to move the arrow. Bring the arrow to the desired item and press the test button to execute testing the item.
- ③ Select EXIT and press the test button to exit from the test mode and return to the game mode.

9-3 MEMORY TEST

When you select MEMORY TEST, test of each IC on the IC Board is executed in the order of CPU ROM TEST → CPU RAM TEST → VIDEO BOARD ROM TEST → VIDEO BOARD RAM TEST.

```
CPU ROM TEST
GOOD (CROM03 MASK) IC. 1
GOOD (CROM02 MASK) IC. 2
GOOD (CROM01 MASK) IC. 3
GOOD (CROM00 MASK) IC. 4
GOOD (CROM13 MASK) IC. 5
GOOD (CROM12 MASK) IC. 6
GOOD (CROM11 MASK) IC. 7
GOOD (CROM10 MASK) IC. 8
GOOD (CROM33 EPROM) IC. 13
GOOD (CROM32 EPROM) IC. 14
GOOD (CROM31 EPROM) IC. 15
GOOD (CROM30 EPROM) IC. 16
GOOD (CROM3 EPROM) IC. 17
GOOD (CROM2 EPROM) IC. 18
GOOD (CROM1 EPROM) IC. 19
GOOD (CROM0 EPROM) IC. 20

PRESS SERVICE BUTTON TO CONTINUE
```

FIG. 9.3 MEMORY TEST (1)

- During test, "TESTING NOW" will be displayed instead of "PRESS SERVICE BUTTON TO CONTINUE" and "PRESS TEST BUTTON TO EXIT" in FIGS. 9.3 a~d.
- As a result of the test, GOOD will be displayed if the IC is satisfactory and BAD will be displayed if the IC is abnormal.
- When the test is complete, if FIGS 9.3 a~d are displayed, it is satisfactory.
- After finishing the VIDEO BOARD RAM TEST, press the test button to return to the menu mode.

```
      CPU RAM TEST

GOOD (SDRAM)           IC. 13 IC. 14 IC. 15 IC. 16
GOOD (BACKUP SRAM)    IC. 21 IC. 22
GOOD (SCROLL SDRAM)  IC. 94
GOOD (SCROLL SRAM)   IC. 17 IC. 18

PRESS SERVICE BUTTON TO CONTINUE
```

FIG.9.3b MEMORY TEST (2)

```
      VIDEO BOARD ROM TEST

GOOD (VROM01)  IC. 26
GOOD (VROM00)  IC. 27
GOOD (VROM03)  IC. 28
GOOD (VROM02)  IC. 29
GOOD (VROM05)  IC. 30
GOOD (VROM04)  IC. 31
GOOD (VROM07)  IC. 32
GOOD (VROM06)  IC. 33
GOOD (VROM11)  IC. 34
GOOD (VROM10)  IC. 35
GOOD (VROM13)  IC. 36
GOOD (VROM12)  IC. 37
GOOD (VROM15)  IC. 38
GOOD (VROM14)  IC. 39
GOOD (VROM17)  IC. 40
GOOD (VROM16)  IC. 41

PRESS SERVICE BUTTON TO CONTINUE
```

FIG.9.3c MEMORY TEST (3)

```
      VIDEO BOARD RAM TEST

PRESS TEST BUTTON TO EXIT
```

FIG.9.3d MEMORY TEST (4)

9-4 BOUNDARY SCAN TEST



Upon finishing the test, cause the Test Menu to return on the screen, turn the power off and turn it back on again. To avoid malfunctioning, perform IC Board initialization by turning the power off and then turning it back on again.

Selecting "BOUNDARY SCAN TEST" causes the Game Board's testing in terms of hardware to be performed automatically.

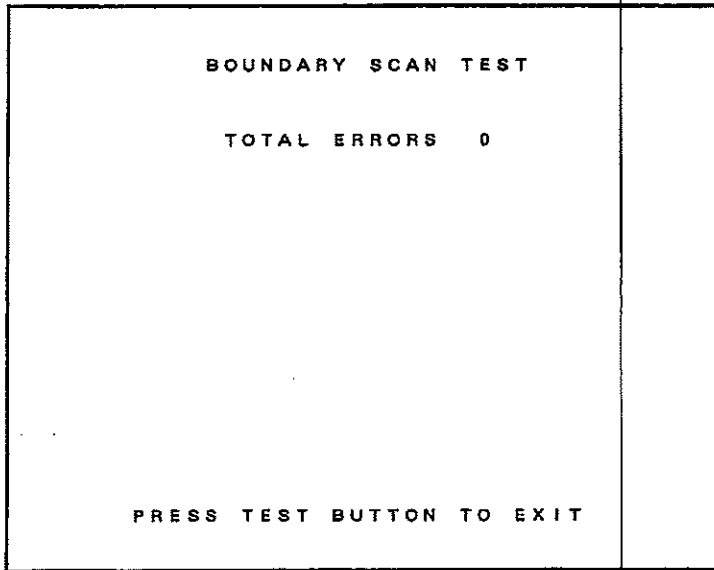

FIG. 9.4 BOUNDARY SCAN TEST

- When the test is completed, if the results are shown as above, it is satisfactory.
- After finishing the test, press the Test button to have the Menu mode return on the screen. Next, turn the power off and then turn it back on again. To avoid malfunctioning, have the Board initialized by turning the power off and then on.
- If there is any hardware problems, error message is displayed. Please contact the offices herein stated or where the product was purchased from.

9-5 INPUT TEST



The volume values in this test are obtained by converting the minimum value to 00 & the maximum value to FF from the Volume values set in the Volume setting mode and thus, differ from the values displayed in the Volume setting mode.

Selecting INPUT TEST displays the following on the screen and enables you to check the status of each switch and each Volume value of the cabinet.

On this screen, periodically check the status of each switch & V.R.

- By pressing each switch, if the display on the right-hand side of the name of each switch changes to ON from OFF, the SW and the wiring connections are satisfactory.
- To check the Coin SW of "COIN #X", open the Coin Chute Door and insert a coin into the Coin Inlet.
- Simultaneously pressing the Service button and the Test button returns the Test Menu on the screen.

INPUT TEST	
HANDLEBAR	80
THROTTLE	00
FRONT BRAKE	00
REAR BRAKE	00
VIEW CHANGE	OFF
MUSIC SELECT	OFF
SHIFT UP	OFF
SHIFT DOWN	OFF
START	OFF
COIN #1	OFF
COIN #2	OFF
SERVICE-SW	OFF
TEST-SW	OFF
PRESS SERVICE+TEST BUTTON TO EXIT	

FIG. 9.5 a INPUT TEST

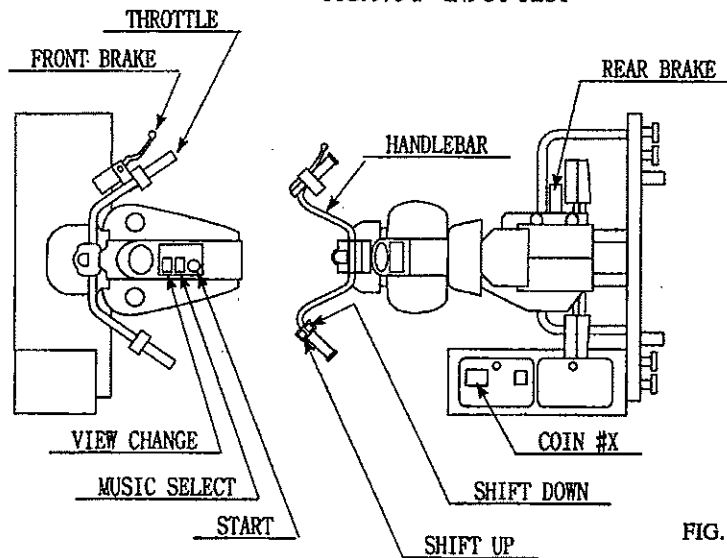

FIG. 9.5 b

- When the Handlebar is turned fully to the left and right, if the HANDLEBAR value varies between 00 (left) and FF (right), and if the value is around 80 when the Handlebar is returned to the center, it is satisfactory.
- When the Accelerator Grip is moved, if the THROTTLE value varies between 00 and FF, and if the value is about 00 when force is not exerted, it is satisfactory.
- When you grip the Front Brake Lever, if the FRONT BRAKE value varies between 00 and FF, and if the value is about 00 when force is not exerted, it is satisfactory.
- When you step on the Rear Brake Pedal, if the REAR BRAKE value varies between 00 and FF, and if the value is about 00 when force is not exerted, it is satisfactory.

9-6 OUTPUT TEST



Depending on the operation when this mode is displayed, the Lock Mechanism functions to lock or unlock. When testing, use care so as to avoid violent falling down accidents.

This mode allows the on-tank button's lamp and lock mechanism functioning to be checked. Periodically check each lamp and lock mechanism in this mode.

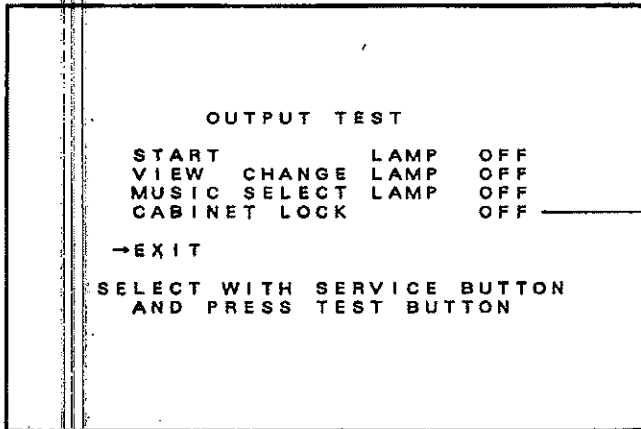

In the Game Assignments, setting "CABINET TYPE" to "STANDARD" causes "RACE LEADER LAMP" to be displayed.

By turning the Handlebar and in the status the Bike Body is banked, if CABINET LOCK is on, the Bike Body is locked in the status as is banked.

FIG. 9.6a OUTPUT TEST

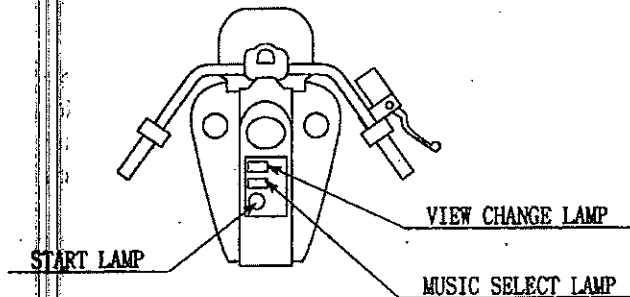
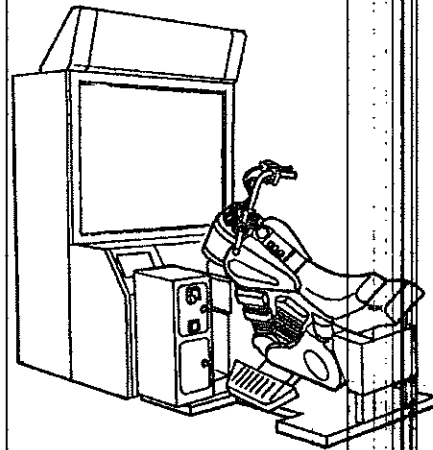

FIG. 9.6b LAMP AND LOCK MECHANISM



- Press the Service button to bring the arrow to each item and press the test button to shift the display beside each item ON↔OFF. When ON is indicated, if the lamp lights up and the lock mechanism functions to secure the Handlebar and Bike Body, and when OFF is indicated, if the lamp lights out and the locking mechanism is unlocked, then each lamp and lock mechanism are satisfactory.
- While the menu mode is displayed, the locking mechanism is unlocked. When this mode is displayed, if OFF is indicated, the locking mechanism is unlocked and when ON is indicated the locking mechanism is locked.

9-7. SOUND TEST

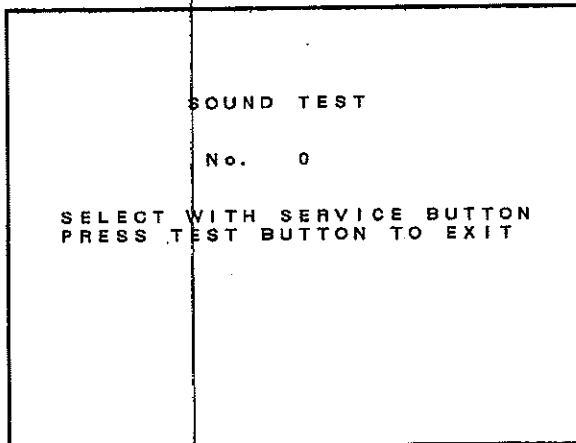

FIG. 9.7 SOUND TEST

This enables sounds used in the game to be checked. Sound related memory and each speaker are checked. Every time the Service button is pressed, the numeral beside No. counts up and different sound is emitted. Press the test button to return to the menu mode (FIG. 9. 2)

9-8 C.R.T. TEST

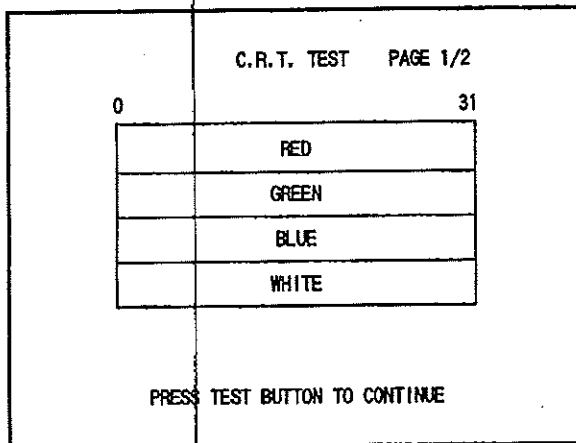

FIG. 9. 8 a C.R.T TEST (1/2)

Select C. R. T. TEST to cause the Monitor to display the screen shown left, allowing Monitor adjustment status to be checked.

Periodically check the Monitor adjustment status on this screen.

The screen (1/2) enables color adjustment check to be performed. The color bar of each of the 4 colors, i. e., red, green, blue and white, is darkest at the extreme left and becomes brighter towards the extreme right.

Press the TEST BUTTON to shift to the next page (2/2).

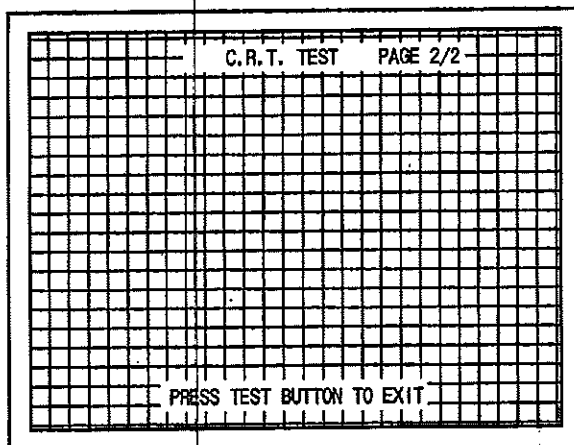

FIG. 9. 8 b C.R.T TEST (2/2)

The screen (2/2) allows screen size and distortion to be tested.

Check if the Crosshatch Frame Line goes out of the screen and if the crosshatch lines are distorted

Press the TEST BUTTON to return to the Menu mode. (FIG. 9. 2)

9-9 GAME ASSIGNMENTS

Selecting the GAME ASSIGNMENTS in the menu mode causes the present game setting to be displayed and also the game setting changes (game difficulty, etc.) can be made. Each item displays the following content.

In the case of communication play, settings in this mode for all of the machines linked for interactive play are the same as those set by the MASTER unit, except for "CABINET TYPE," "B.G.M. VOLUME," and "ENGINE VOLUME."

GAME ASSIGNMENTS		
DIFFICULTY		NORMAL
ADVERTISE SOUND		ON
CABINET TYPE		DELUXE
B. G. M. VOLUME		4
ENGINE VOLUME		8
NUMBER OF STAGES		4
TOURNAMENT MODE		ON
START		
MONTH	DEC	
DAY	25	
YEAR	1997	
HOUR	18	
END		
MONTH	DEC	
DAY	25	
YEAR	1997	
HOUR	18	
DURATION	DAILY	
→ EXIT		
SELECT WITH SERVICE BUTTON AND PRESS TEST BUTTON		

If the TOURNAMENT mode is set to OFF, these are not displayed.

FIG. 9.9 GAME ASSIGNMENTS

SETTING CHANGE PROCEDURE

- ① Press the SERVICE BUTTON to move the arrow ">" to the desired item.
- ② Choose the desired setting change item by using the TEST BUTTON.
- ③ To return to the MENU mode, move the arrow to EXIT and press the TEST BUTTON.

- **DIFFICULTY :** The remaining time awarded at the time of starting game is set in increments of 5 seconds.
- **ADVERTISE SOUND :** Sets whether ADVERTISE sound is to be emitted or not.
To emit sound: ON Not to emit sound: OFF
- **CABINET TYPE :** Set to "DELUXE" or "STANDARD" as applicable. Setting to a wrong type can cause the following failure. Be sure to set correctly.
 - Example of failure: ○ Locking mechanism in the deluxe type does not function satisfactorily
 - The cabinet appearing in the operation explanation mode differs from the type to be used.
- **B. G. M. VOLUME :** BGM VOLUME adjustment (1~8)
- **ENGINE VOLUME :** ENGINE VOLUME adjustment (1~8)
- **NUMBER OF STAGES :** Sets the number of stages needed to accomplish Game Clear. (3, 4, and 5)
- **TOURNAMENT MODE :** During the period set, special bookkeeping for ranking is executed. When set to ON, as shown above, the date of TOURNAMENT mode start, the end date of TOURNAMENT mode, and items of bookkeeping periods are displayed. DURATION refers to the unit of bookkeeping periods. The setting can be selected from among DAILY, WEEKLY, BI-WEEKLY, and MONTHLY.

Note: Be sure to set the present time when the TOURNAMENT mode is set to ON (9 - 13).

9-10 COIN ASSIGNMENTS

The "COIN ASSIGNMENTS" mode permits you to set the start number of credits, as well as the basic numbers of coins and credits. This mode expresses "how many coins correspond to how many credits."

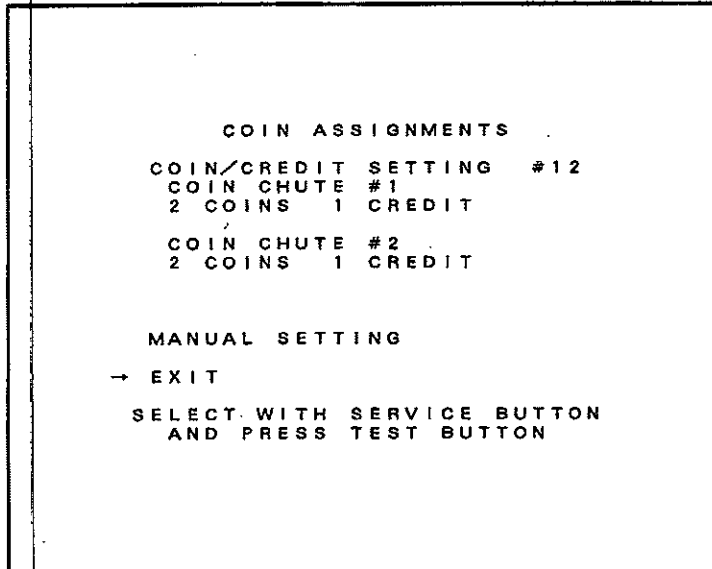

FIG. 9.10 a COIN ASSIGNMENTS

- **COIN/CREDIT SETTING** "How many coins correspond to how many credits." In this machine, selection as per Table 9. 10a is possible.
- **MANUAL SETTING** Allows for finer settings. (Table 9. 10 b)

SETTING CHANGE PROCEDURE

- ① Press the Service button to bring the arrow to COIN/CREDIT setting.
- ② Press the TEST BUTTON to choose the desired setting item.
- ③ Bring the arrow to EXIT and press the TEST BUTTON to return to the menu mode.

TABLE 9.10a COIN/CREDIT SETTING

NAME OF SETTING	FUNCTIONING OF COIN CHUTE #1		FUNCTIONING OF COIN CHUTE #2	
SETTING #1	1 COIN	1 CREDIT	1 COIN	1 CREDIT
SETTING #2	1 COIN	2 CREDITS	1 COIN	1 CREDIT
SETTING #3	1 COIN	3 CREDITS	1 COIN	1 CREDIT
SETTING #4	1 COIN	4 CREDIT S	1 COIN	1 CREDIT
SETTING #5	1 COIN	5 CREDITS	1 COIN	1 CREDIT
SETTING #6	1 COIN	2 CREDITS	1 COIN	2 CREDITS
SETTING #7	1 COIN	5 CREDITS	1 COIN	2 CREDITS
SETTING #8	1 COIN	3 CREDITS	1 COIN	3 CREDITS
SETTING #9	1 COIN	4 CREDITS	1 COIN	4 CREDITS
SETTING #10	1 COIN	5 CREDITS	1 COIN	5 CREDITS
SETTING #11	1 COIN	6 CREDITS	1 COIN	6 CREDITS
SETTING #12	2 COINS	1 CREDIT	2 COINS	1 CREDIT
SETTING #13	1 COIN	1 CREDIT	2 COINS	1 CREDIT
SETTING #14	1 COIN	2 CREDITS	2 COINS	1 CREDIT
SETTING #15	1 COIN	1 CREDIT	1 COIN	1 CREDIT
	2 COINS	3 CREDITS	2 COINS	3 CREDITS
SETTING #16	1 COIN	3 CREDIT S	1 COIN	1 CREDITS
			2 COINS	3 CREDITS
SETTING #17	3 COINS	1 CREDIT	3 COINS	1 CREDIT
SETTING #18	4 COINS	1 CREDIT	4 COINS	1 CREDIT
SETTING #19	1 COIN	1 CREDIT	1 COIN	1 CREDIT
	2 COINS	2 CREDITS	2 COINS	2 CREDITS
	3 COINS	3 CREDITS	3 COINS	3 CREDITS
	4 COINS	5 CREDITS	4 COINS	5 CREDITS
SETTING #20	1 COIN	5 CREDITS	1 COIN	1 CREDIT
			2 COINS	2 CREDITS
			3 COINS	3 CREDITS
			4 COINS	5 CREDITS
SETTING #21	5 COINS	1 CREDIT	5 COINS	1 CREDIT
SETTING #22	1 COIN	2 CREDITS	3 COINS	1 CREDIT
			5 COINS	2 CREDITS
SETTING #23	2 COINS	1 CREDIT	2 COINS	1 CREDIT
	4 COINS	2 CREDITS	4 COINS	2 CREDITS
	5 COINS	3 CREDITS	5 COINS	3 CREDITS
SETTING #24	1 COIN	3 CREDIT	2 COINS	1 CREDIT
			4 COINS	2 CREDITS
			5 COINS	3 CREDITS
SETTING #25	1 COIN	1 CREDIT	1 COIN	1 CREDIT
	2 COINS	2 CREDITS	2 COINS	2 CREDITS
	3 COINS	3 CREDITS	3 COINS	3 CREDITS
	4 COINS	4 CREDITS	4 COINS	4 CREDITS
	5 COINS	6 CREDITS	5 COINS	6 CREDITS
SETTING #26	1 COIN	1 CREDIT	1 COIN	1 CREDIT
			2 COINS	2 CREDITS
			3 COINS	3 CREDITS
			4 COINS	4 CREDITS
			5 COINS	6 CREDITS
SETTING #27	FREE PLAY		FREE PLAY	

MANUAL SETTING

```
MANUAL SETTING
COIN TO CREDIT 1 COIN      1 CREDIT
BONUS ADDER      NO BONUS ADDER
COIN CHUTE #1 MULTIPLIER
1 COIN COUNTS AS 1 COIN
COIN CHUTE #2 MULTIPLIER
1 COIN COUNTS AS 1 COIN

→ EXIT

SELECT WITH SERVICE BUTTON
AND PRESS TEST BUTTON
```

FIG.9.10b COIN ASSIGNMENTS

- COIN TO CREDIT Determines conversion coin/credit.
- BONUS ADDER This sets how many conversion coins should be inserted to obtain one SERVICE COIN.
- COIN CHUTE #X MULTIPLIER This sets how many inserted tokens one conversion coin represents.

TABLE 9.10b MANUAL SETTING

COIN TO CREDIT	1 COIN	1 CREDIT
	2 COINS	1 CREDIT
	3 COINS	1 CREDIT
	4 COINS	1 CREDIT
	5 COINS	1 CREDIT
	6 COINS	1 CREDIT
	7 COINS	1 CREDIT
	8 COINS	1 CREDIT
	9 COINS	1 CREDIT

BONUS ADDER	NO BONUS ADDER	
	2 COINS GIVE	1 EXTRA COIN
	3 COINS GIVE	1 EXTRA COIN
	4 COINS GIVE	1 EXTRA COIN
	5 COINS GIVE	1 EXTRA COIN
	6 COINS GIVE	1 EXTRA COIN
	7 COINS GIVE	1 EXTRA COIN
	8 COINS GIVE	1 EXTRA COIN
	9 COINS GIVE	1 EXTRA COIN

COIN CHUTE MULTIPLIER	1 COIN COUNTS AS 1 COIN
	1 COIN COUNTS AS 2 COINS
	1 COIN COUNTS AS 3 COINS
	1 COIN COUNTS AS 4 COINS
	1 COIN COUNTS AS 5 COINS
	1 COIN COUNTS AS 6 COINS
	1 COIN COUNTS AS 7 COINS
	1 COIN COUNTS AS 8 COINS
	1 COIN COUNTS AS 9 COINS

9-11 NETWORK ASSIGNMENTS

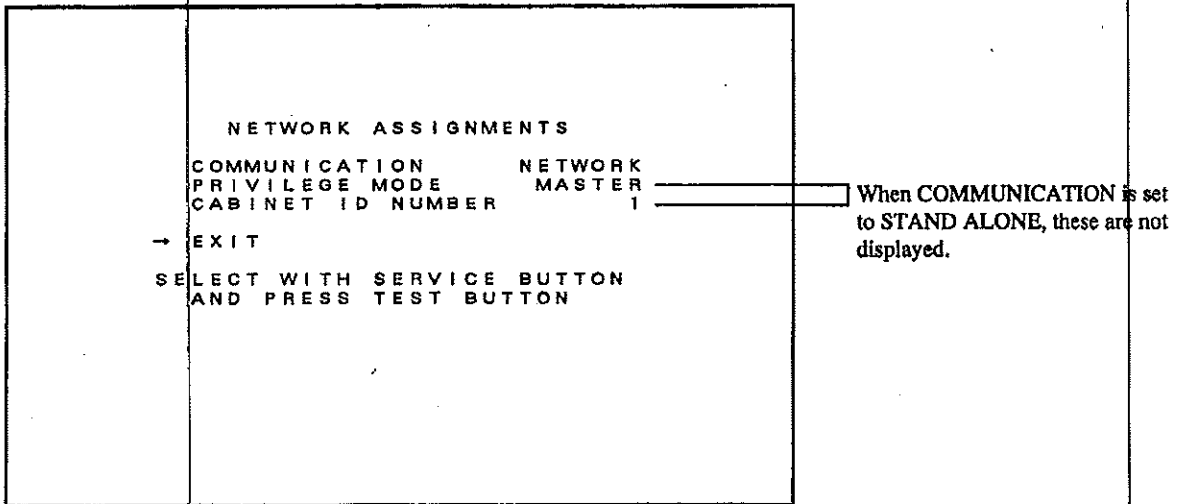

FIG. 9.11 NETWORK ASSIGNMENTS

- **COMMUNICATION**
Select NETWORK or STAND ALONE. When NETWORK is selected, the following are displayed.
- **PRIVILEGE MODE**
In the case plural machines are used for interactive play, set one of them to MASTER and set the rest of them to SLAVE. The Game Assignments set to the MASTER cabinet will also be applied to the SLAVE cabinets. Changing the settings by the SLAVE units is ineffective.
- **CABINET ID NUMBER**
In the case plural machines are linked for interactive play, set the CABINET ID NUMBER in the order of 1, 2, 3, and 4 starting from the leftmost cabinet as seen from the front of the cabinet. If an identical number is set to 2 or more cabinets or if setting is made in the wrong order, the display during game will be incorrect. Be very careful of this point.

9-12 VOLUME ADJUSTMENTS



At the time of HANDLEBAR VOLUME setting, the Bike banks to a great extent as the handlebar is turned fully within the movable range. Use care so as not to cause falling down accidents.

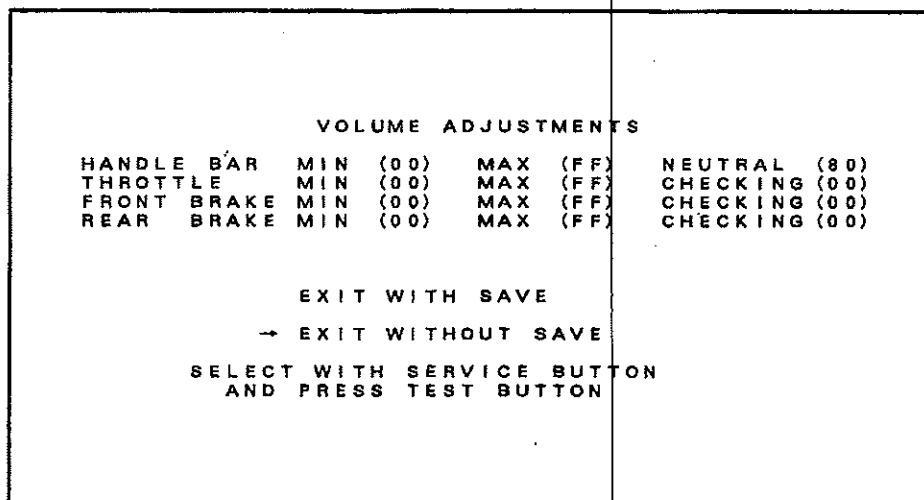

FIG. 9.12 a VOLUME ADJUSTMENTS

In the case an appropriate value is not displayed in the INPUT TEST mode, the Volume value can be adjusted in this mode.

Set an appropriate Volume value by moving the Handlebar, Accelerator Grip, Front Brake Lever, and Rear Brake Pedal fully within the movable range. The numeral values are hexadecimally displayed.

HANDLE BAR

After turning the handlebar fully to the left and right, return it to the center and ensure the status in which force is not exerted.

ACCELERATOR (THROTTLE)

After fully moving the Accelerator Grip, let go your hold and return to the status in which force is not exerted.

FRONT BRAKE

Fully grip the front brake and let go your hold, then return to the status force is not exerted.

REAR BRAKE

Fully step on the Rear Brake Pedal and then release to return to the status force is not exerted

The value in the parenthesis () refers to the real value (without conversion) and differs from the Volume value shown in the INPUT TEST mode (FIG. 9. 5 a).

- Bring the cursor to EXIT WITH SAVE and press the test button to have the contents of the new input setting registered and to return to the menu mode.
- Bring the cursor to EXIT WITHOUT SAVE and press the test button to return to the menu mode without changing the contents of the setting.

If adjustment can not be made even in the setting of this mode, then Volume Gear deviation and Volume malfunctioning may be considered. Refer to Sections 10 and 11 to take countermeasures.

APPROPRIATE VALUE OF VOLUME

When force is not exerted and hands and feet are released, if the following values are displayed, and when force is applied, if Volume value varies in a natural manner, then the Volume is appropriately secured and satisfactorily functioning.

HANDLE BAR	80 ± 5
THROTTLE	} 20 ± 5
FRONT BRAKE	
REAR BRAKE	

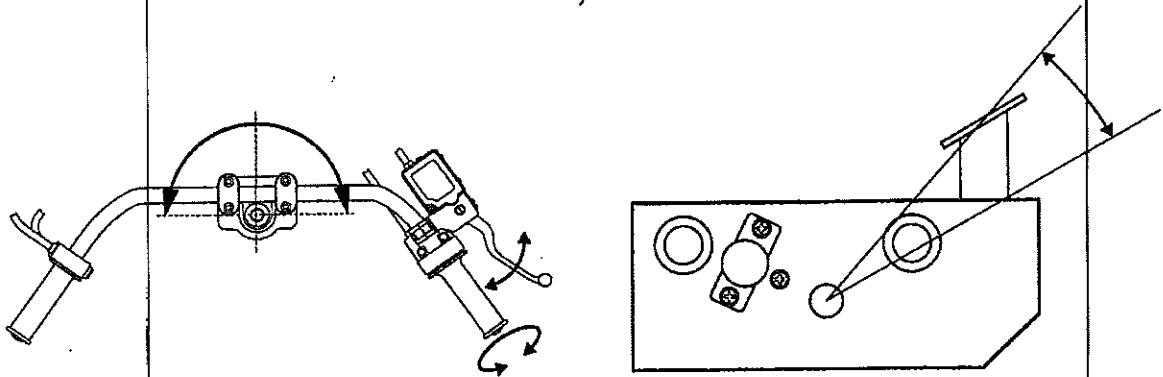

VOLUME INPUT by moving fully within the movable range.

FIG. 9. 12 b



Check time setting every month, and correct if time setting is incorrect. Failing to observe this can cause the TOURNAMENT mode display to be irregular.

The system of the product has calendar functions. In the Game Assignments, if the TOURNAMENT mode is set to ON, ensure that the present time is correct in this mode. If the TOURNAMENT mode is not used, the present time need not be adjusted.

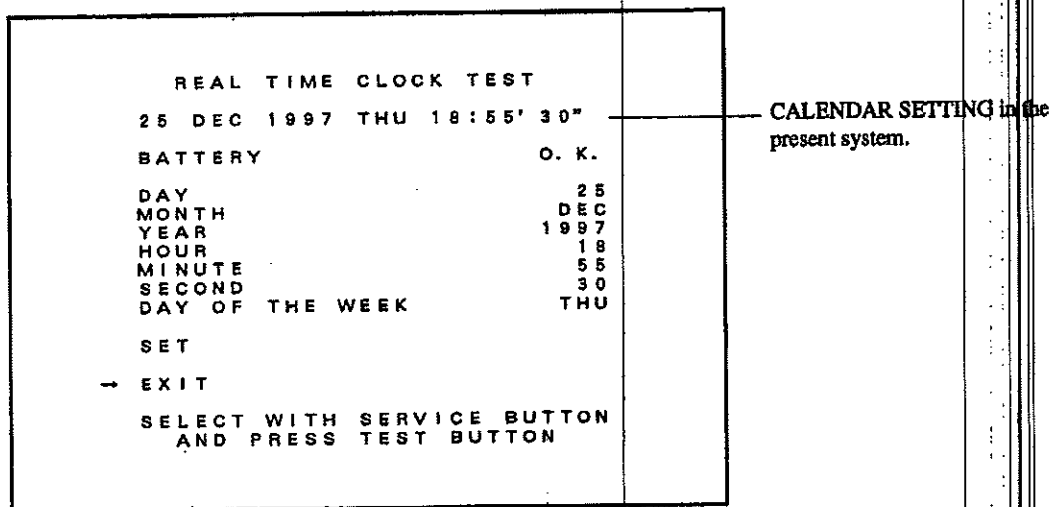

FIG. 9.13 REAL TIME CLOCK TEST

SETTING CHANGE PROCEDURE

- ① Press the Service button and bring the arrow to the desired item to be changed.
- ② Press the test button and bring the arrow to year, month, day, and hour to be set. "DAY OF THE WEEK" is automatically determined when year, month, and day are set.
- ③ Bring the arrow to "SET" and press the test button. The system calendar display changes to the time set.
- ④ Move the arrow to "EXIT" and press the test button to return to the menu mode. Time can not be changed unless procedure ③ above is not performed.

● **BATTERY** Indicates the status of the on-game-board battery. If "ERROR" is displayed, some sort of trouble must have occurred. Contact where you purchased the product from or the office herein stated.

9-14 BOOKKEEPING

Selecting the **BOOKKEEPING** in the menu mode displays the bookkeeping data up to the present on the following 2 pages:

Press the **TEST** button again to proceed to the next page.

BOOKKEEPING		PAGE 1/2
COIN REPORT		
COIN CHUTE #1		0
COIN CHUTE #2		0
TOTAL COINS		0
COIN CREDITS		0
SERVICE CREDITS		0
TOTAL CREDITS		0
NUMBER OF GAMES		0
TOTAL	TIME	0D 0H 0M 0S
TOTAL	PLAY TIME	0D 0H 0M 0S
AVERAGE	PLAY TIME	0H00M00S
LONGEST	PLAY TIME	0H00M00S
SHORTEST	PLAY TIME	0H00M00S
PRESS TEST BUTTON TO CONTINUE		

FIG. 9.14 a BOOKKEEPING (1/2)

BOOKKEEPING		PAGE 2/2
TIME HISTOGRAM		
0M00S ~ 0M29S		0
0M30S ~ 0M59S		0
1M00S ~ 1M29S		0
1M30S ~ 1M59S		0
2M00S ~ 2M29S		0
2M30S ~ 2M59S		0
3M00S ~ 3M29S		0
3M30S ~ 3M59S		0
4M00S ~ 4M29S		0
4M30S ~ 4M59S		0
5M00S ~ 5M29S		0
5M30S ~ 5M59S		0
6M00S ~ 6M29S		0
6M30S ~ 6M59S		0
7M00S ~ 7M29S		0
7M30S ~ 7M59S		0
8M00S ~ 8M29S		0
8M30S ~ 8M59S		0
9M00S ~ 9M29S		0
9M30S ~ 9M59S		0
OVER 10M00S		0
PRESS TEST BUTTON TO EXIT		

FIG. 9.14 b BOOKKEEPING (2/2)

- **COIN CHUTE** Number of coins put in. As seen from the front of the cabinet, the right-hand side is #1 and the left-hand side is #2.
- **TOTAL COINS** Total number of coins inserted in each coin chute.
- **COIN CREDITS** Number of credits registered by inserting coins
- **SERVICE CREDITS** Credits registered by the **SERVICE** button
- **TOTAL CREDITS** Total number of credits
(COIN CREDITS + SERVICE CREDITS)
- **TOTAL TIME** The total energized time.
- **TIME HISTOGRAM** By-playtime play frequency.

9-15 BACKUP DATA CLEAR

The contents of BOOKKEEPING can be cleared. When clearing the BOOKKEEPING contents, bring the arrow to "YES (CLEAR)" by using the Service button, and press the Test button. When clearing is finished, "COMPLETED" will be displayed and then the menu mode returns. Bring the arrow to "NO (CANCEL)" and press the Test button to have the Menu mode return on the screen without clearing the data. Note that this operation does not affect the contents of the game setting.

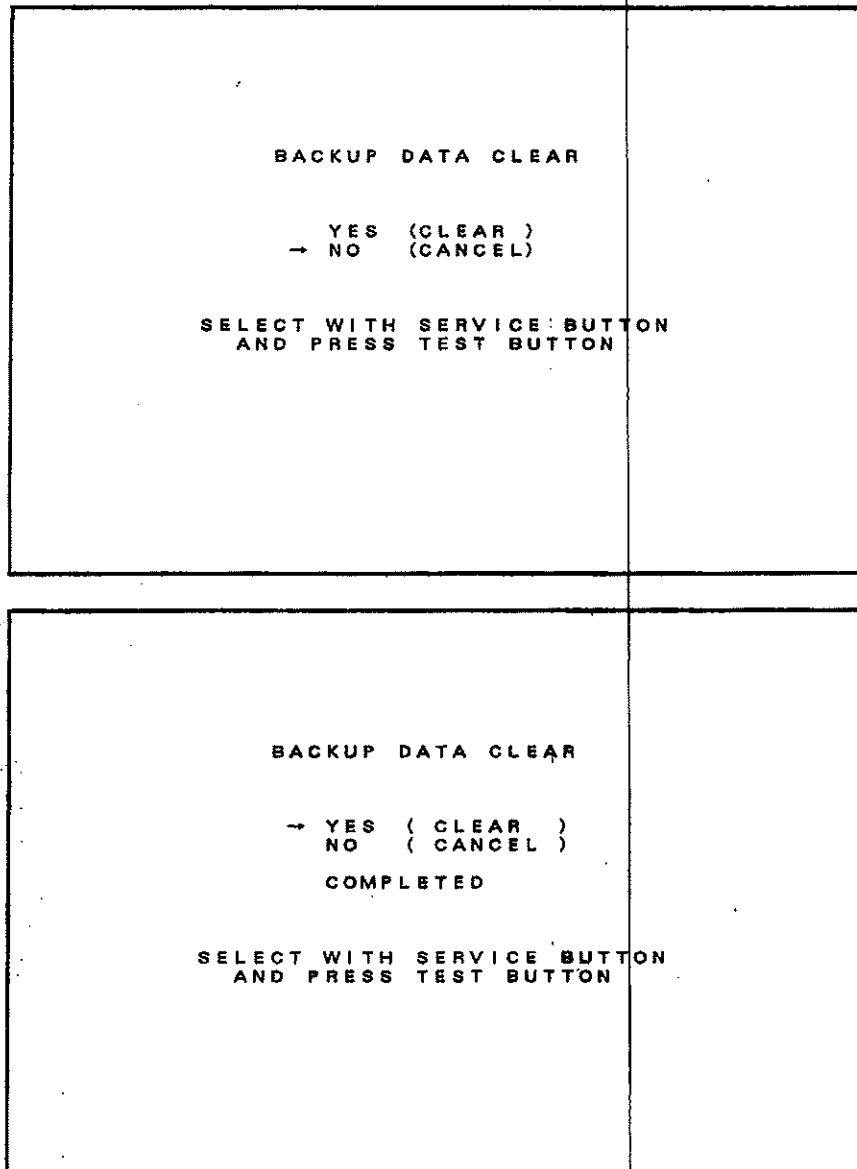

FIG. 9.15 BACKUP DATA CLEAR

10. HANDLEBAR



- In order to prevent an electric shock and short circuit, be sure to turn power off before performing work by touching the interior parts of the product.
- Be careful so as not to damage wirings. Damaged wiring can cause an electric shock or short circuit accident.
- Do not touch places other than those specified. Touching places not specified can cause an electric shock or short circuit accident.

10-1 ADJUSTING / REPLACING THE FRONT BRAKE VOLUME

In the test mode, if the Front Brake Volume's value movements are irregular, adjust or replace the Volume by using the following procedure.
Take out the 4 screws and remove the VR Cover.
The Front Brake Volume is inside the VR Cover.

VOLUME ADJUSTMENT

- ① Loosen the 2 screws which secure the VR Bracket to move the VR Bracket.
- ② Move the VR Bracket to disengage gear mesh.
- ③ By adjusting gear mesh, fasten the 2 screws which secure the VR Bracket.
- ④ Move the Brake Lever fully to the movable range and check if the Volume Shaft's revolvable range is exceeded.
- ⑤ After the adjustment, be sure to perform the Volume setting in the test mode.

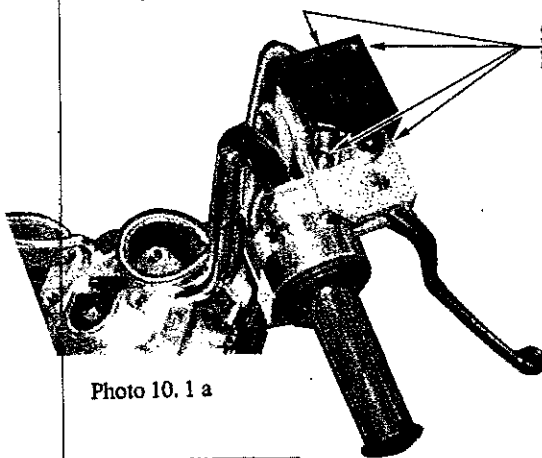

Photo 10.1 a

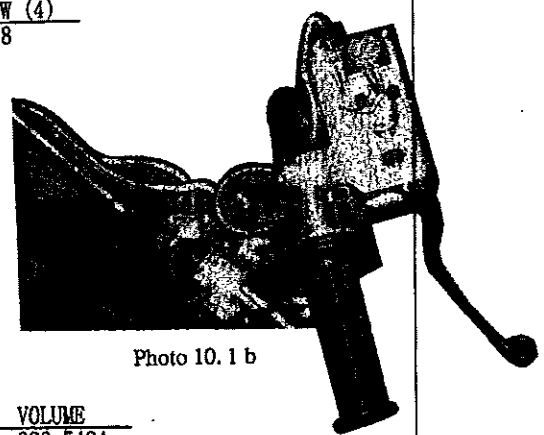

Photo 10.1 b

VOLUME REPLACEMENT

Replace the Volume if it is malfunctioning. Install the Volume in the manner so that $20H \pm 5$ is indicated when force is not exerted.

- ① Remove the 2 screws which secure the VR Bracket.
- ② Remove the Volume Gear from the Volume Shaft and remove the Volume from the VR Bracket to replace the Volume.
- ③ After the replacement, be sure to perform the Volume setting in the test mode.

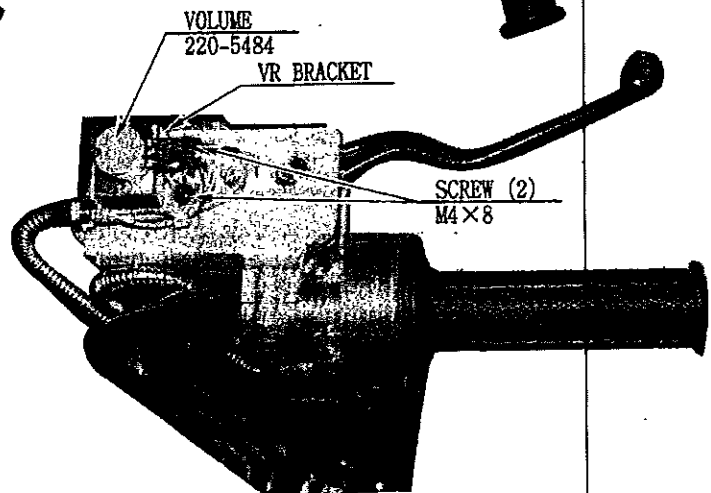

Photo 10.1 c

10-2 ADJUSTING / REPLACING THE ACCELERATOR VOLUME

In the test mode, if the Accelerator Volume's value movements are irregular, adjust or replace the Volume by using the following procedure.

Remove the 4 screws, and the VR Cover. The Accelerator Volume appears inside the Cover.

VOLUME ADJUSTMENT

- ① Loosen the screw which secures the VR Bracket to move the VR Bracket.
- ② Move the VR Bracket to disengage gear mesh.
- ③ By adjusting gear mesh, fasten the screw which secures the VR Bracket.
- ④ Turn the Accelerator Grip fully to the movable range and check if the Volume Shaft's revoluble range is exceeded.
- ⑤ After the adjustment, be sure to perform the Volume setting in the test mode.

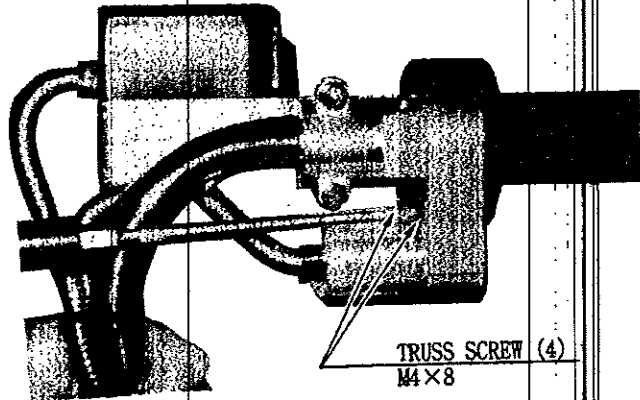

Photo 10.2 a

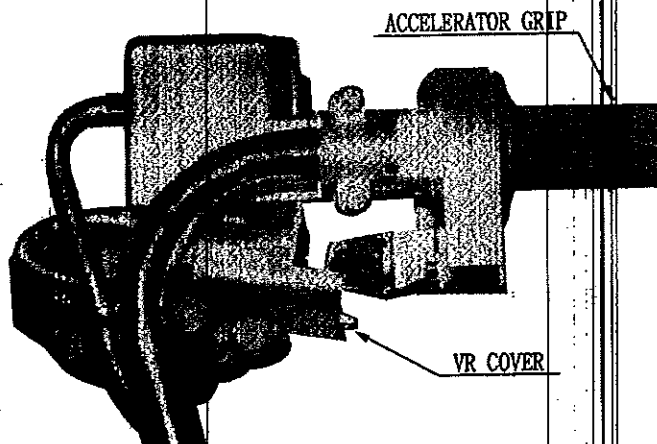

Photo 10.2 b

VOLUME REPLACEMENT

Replace the Volume if it is malfunctioning. Install the Volume in the manner so that $20H \pm 5$ is indicated when force is not exerted.

- ① Remove the screw which secures the VR Bracket.
- ② Remove the Volume Gear from the Volume Shaft and remove the Volume from the VR Bracket to replace the Volume.
- ③ After the replacement, be sure to perform the Volume setting in the test mode.

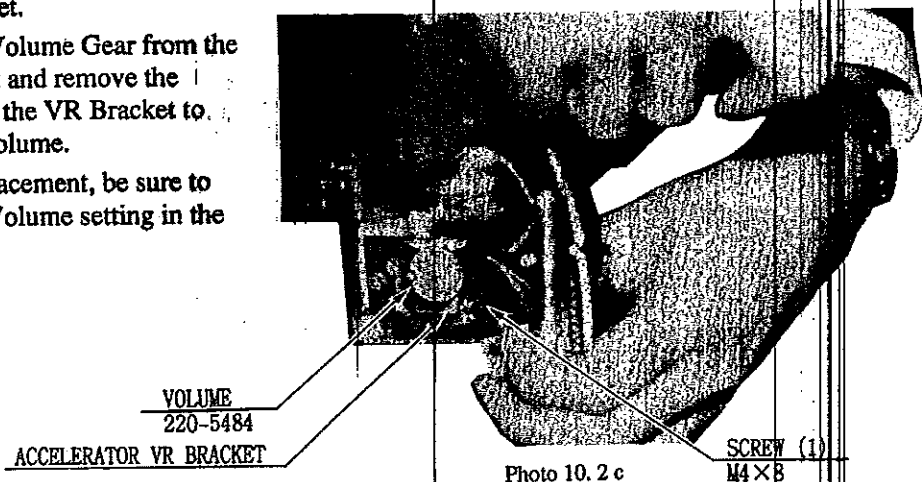

Photo 10.2 c

10-3 ADJUSTING / REPLACING THE HANDLEBAR VOLUME

In the test mode, if the Handlebar Volume's value movements are irregular, adjust or replace the Volume.

- ① Remove the Bolt and remove the Handlebar Washer.

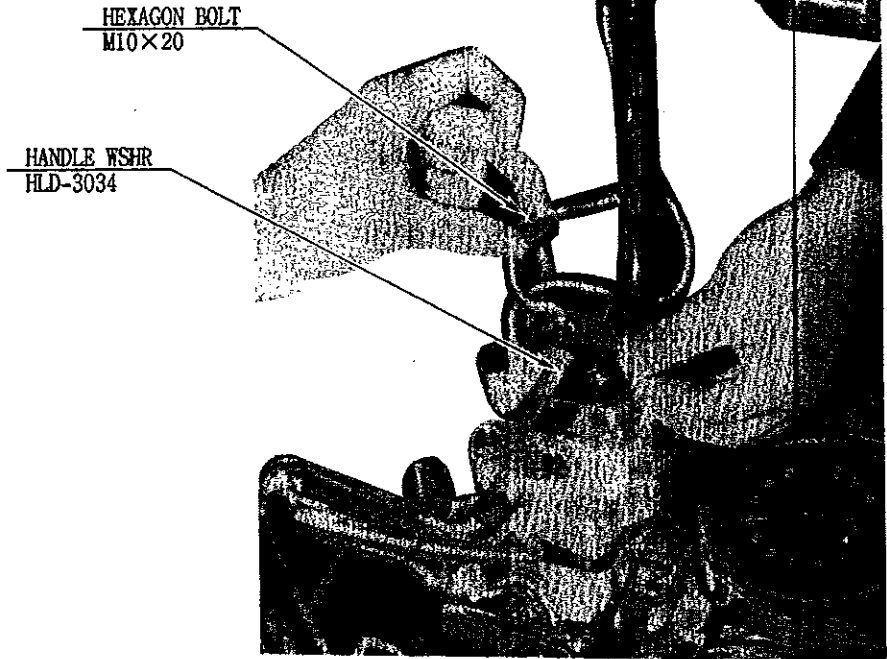

Photo 10.3 a

- ② Remove the 3 screws which secure the Center Cover.

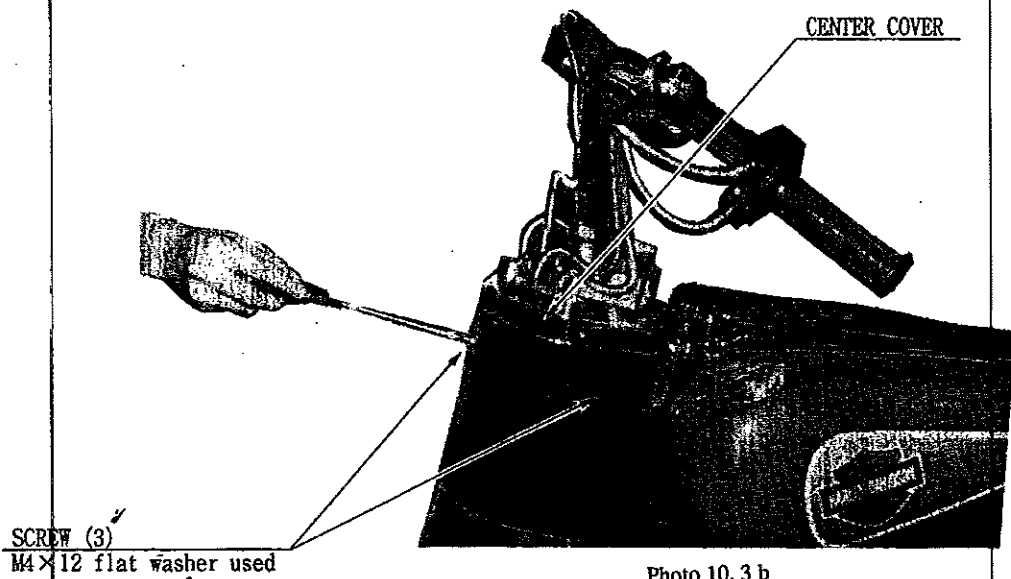

Photo 10.3 b

- ③ Remove the Handlebar and Center Cover. Wiring connections are inside the Center Cover. When working, use care so as not to damage the wiring.

- ④ Disconnect the 3 connectors which are connected to the Handlebar.
- ⑤ The Handlebar Volume is inside the Cover.

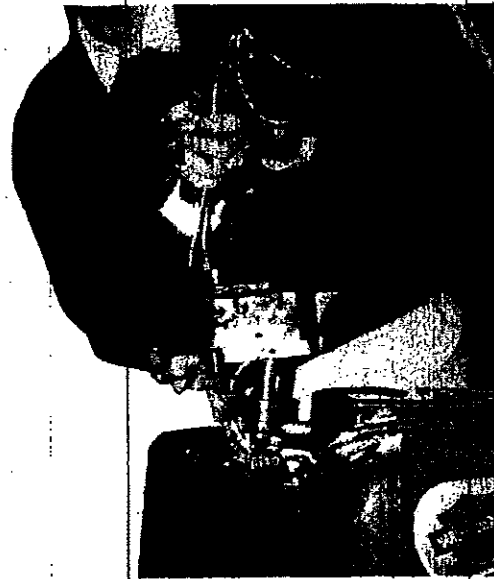

Photo 10.3 c

VOLUME ADJUSTMENT

- ① Loosen the 2 screws which secure the VR Bracket to move the VR Bracket.
- ② Move the VR Bracket to disengage gear mesh.
- ③ By adjusting gear mesh, fasten the 2 screws which secure the VR Bracket.
- ④ Turn the handle shaft fully to the movable range and check if the volume shaft's revolvable range is exceeded.
- ⑤ After the adjustment, be sure to perform the Volume setting in the test mode.

CONNECTORS (3)



Photo 10.3 d

VOLUME REPLACEMENT

- Replace the Volume if it is malfunctioning. Install the Volume in the manner so that $80H \pm 5$ is indicated when force is not exerted.
- ① Remove the 2 screws which secure the VR Bracket.
 - ② Remove the Volume Gear from the Volume Shaft and remove the Volume from the VR Bracket to replace the Volume.
 - ③ After the replacement, be sure to perform the Volume setting in the test mode.

SCREW (2)
M4×8, w/flat & spring washers

VOLUME
220-5484

HANDLE SHAFT

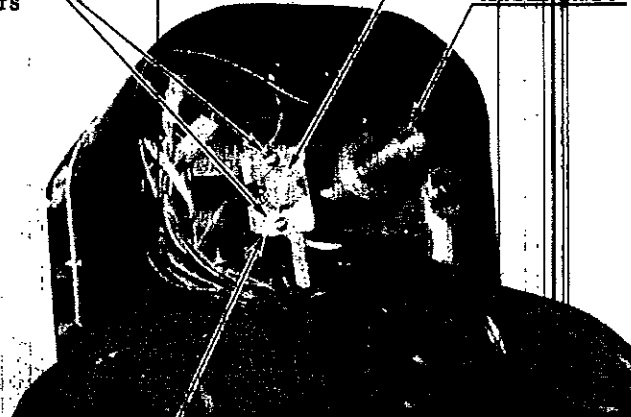

VR BRACKET

Photo 10.3 e

10-4 GREASING

STOP
IMPORTANT!

- Be sure to use the designated grease. Using undesignated grease can cause parts damage.
- Do not apply greasing to places other than those specified. Greasing to undesignated places can cause malfunctioning and the qualitative deterioration of parts.

Once every 3 months, apply greasing to the following places.
For greasing, use Grease Mate (P. No. 090-0066).

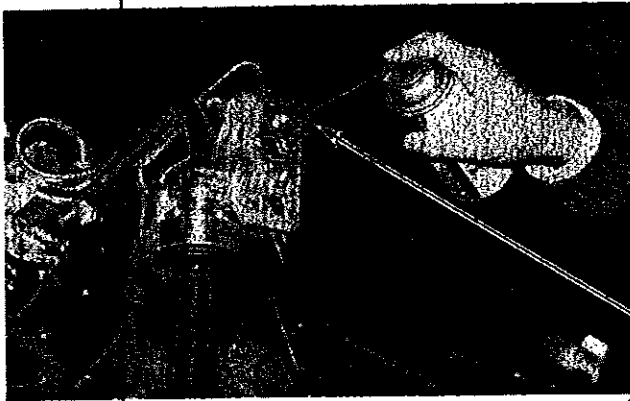

GEAR MESH PORTION



SLIDING FACE OF BRAKE LEVER

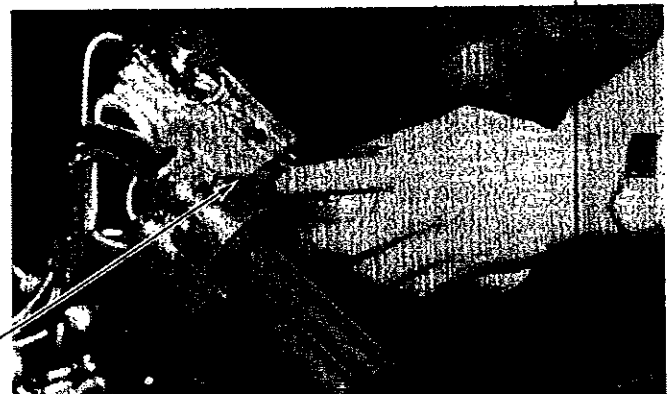
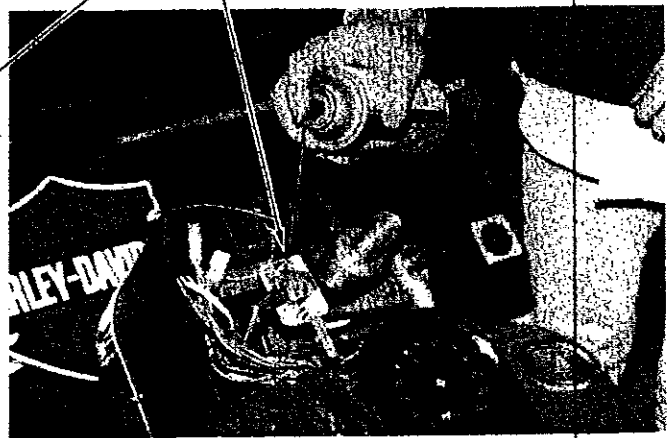

Photo 10.4

11. BIKE MECHA



- In order to prevent an electric shock and short circuit, be sure to turn power off before performing work by touching the interior parts of the product.
- Be careful so as not to damage wirings. Damaged wiring can cause an electric shock or short circuit accident.
- Do not touch places other than those specified. Touching places not specified can cause an electric shock or short circuit accident.

11-1 ADJUSTING AND REPLACING THE REAR BRAKE VOLUME

In the test mode, if the Rear Brake's (Foot Brake's) volume movements are irregular, adjust or replace the Volume by using the following procedure.

- ① Remove the 2 hexagon nuts and the step.

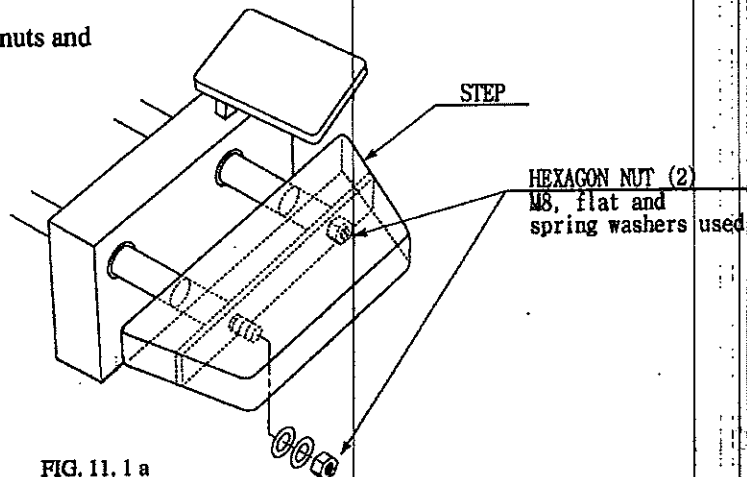

FIG. 11. 1 a

- ② The Foot Brake is installed in the status inserted into the Bike Mecha's 2 shafts. Remove the Foot Brake from the Bike Mecha in the manner to pull out from the 2 shafts. The Foot Brake has wiring connections. Use care so as not to damage the wiring.
- ③ Disconnect the connector and remove the Foot Brake from the Bike Mecha.



Photo 11. 1 a

VOLUME ADJUSTMENT

Remove the step, and the screw which secures the Adjust Gear appears.

Loosen the 2 securing screws to make fine adjustment of Volume gear mesh.

If adjustment can not be made by fine adjustment, remove the Foot Brake and make adjustment by using the following procedure.

- ① Loosen the 2 screws which secure the VR Bracket to move the VR Bracket.
- ② Move the VR Bracket to disengage gear mesh.
- ③ By adjusting gear mesh, fasten the 2 screws which secure the VR Bracket.
- ④ Move the Foot Brake's Pedal fully to the movable range, and check if the Volume Shaft's revolvable range is exceeded.
- ⑤ After the adjustment, be sure to perform the Volume setting in the test mode.

VOLUME REPLACEMENT

Replace the Volume if it is malfunctioning. Install the Volume in the manner so that $20H \pm 5$ is indicated when force is not applied.

- ① Remove the 2 screws which secure the VR Bracket.
- ② Remove the Volume Gear from the Volume Shaft and remove the Volume from the VR Bracket to replace the Volume.
- ③ After the replacement, be sure to perform the Volume setting in the test mode.

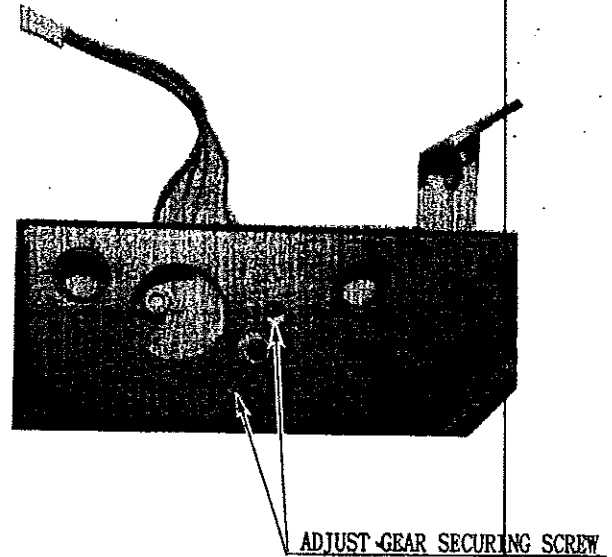

Photo 11. 1 b

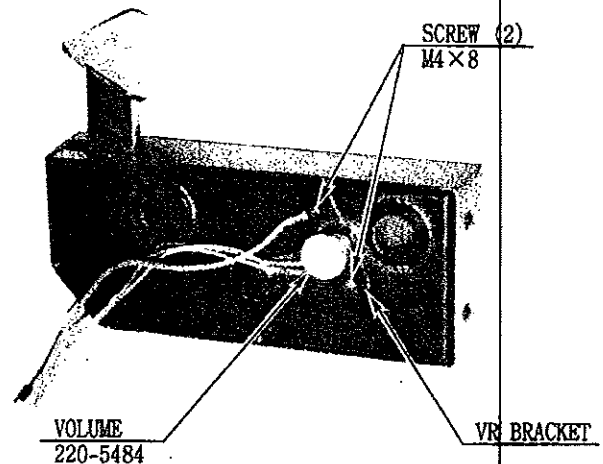

Photo 11. 1 c

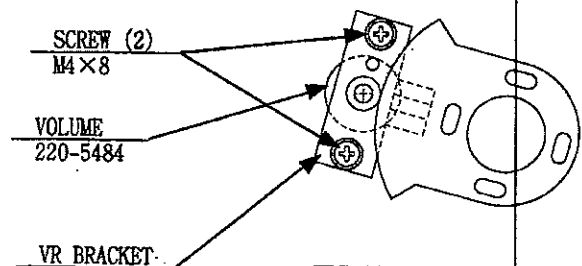

FIG. 11. 1 b

11-2 GREASING

STOP
IMPORTANT

- Be sure to use the designated grease. Using undesignated grease can cause parts damage.
- Do not apply greasing to places other than those specified. Greasing to undesignated places can cause malfunctioning and the qualitative deterioration of parts.

Once every 3 months, apply greasing to the following places.
For greasing, use Grease Mate (P. No. 090-0066).

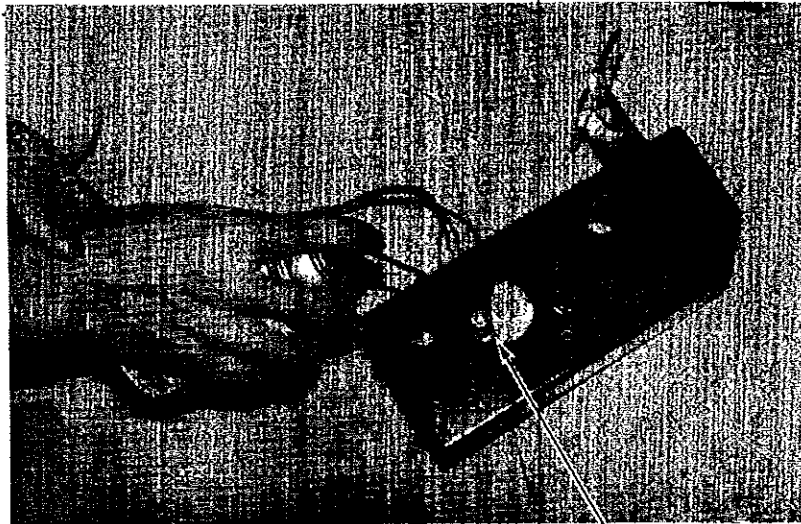

Photo 11.2

GEAR MESH PORTION

11-3 REPLACEMENT OF SAFETY RUBBER



The SAFETY RUBBER is an important, hazard preventative part. Before commencing daily operation, be sure to check for damage and omission. Operating with the Safety Rubber damaged and omitted can cause injury such as the player's finger(s) being caught (in the damaged or omitted portion).

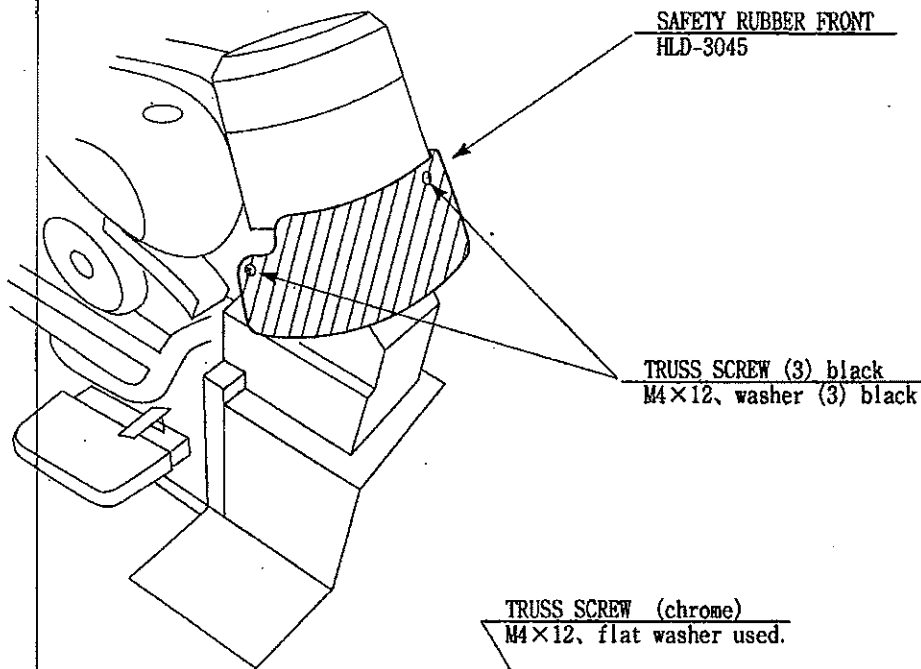

FIG. 11.3 a

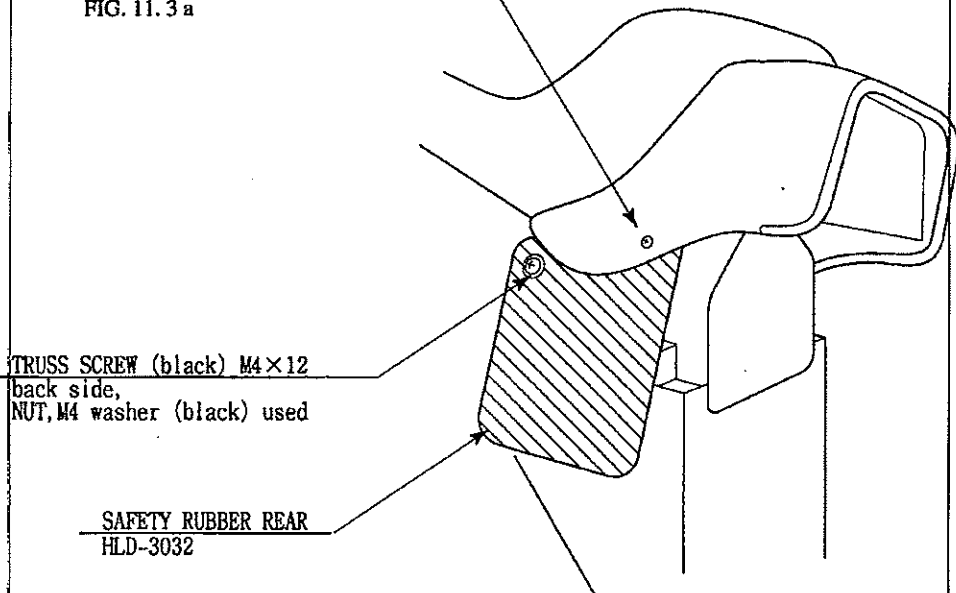

PHOTO 11.3 b

12. COIN SELECTOR

HANDLING THE COIN JAM

If the coin is not rejected when the REJECT button is pressed, open the coin chute door and open the selector gate. After removing the jammed coin, put a normal coin in and check to see that the selector correctly functions.

CLEANING THE COIN SELECTOR

STOP

IMPORTANT

- Remove and clean smears by using a soft cloth dipped in water or diluted chemical detergent and then squeezed dry.
- Never apply machine oil, etc. to the Coin Selector.
- After cleaning the Coin Selector, insert a regular coin in the normal working status and ensure that the Selector correctly functions.

The coin selector should be cleaned once every 3 months. When cleaning, follow the procedure below:

- ① Turn the power for the machine OFF. Open the coin chute door.
- ② Open the gate and dust off by using a soft brush (made of wool, etc.).
- ③ Remove and clean smears by using a soft cloth dipped in water or diluted chemical detergent and then squeezed dry.
- ④ Remove the CRADLE.
When removing the retaining ring (E ring), be very careful so as not to bend the shaft.
- ⑤ Remove stain from the shaft and pillow portions by wiping off with a soft cloth, etc.
- ⑥ After wiping off as per ⑤ above, further apply a dry cloth, etc. to cause the coin selector to dry completely.

COIN INSERTION TEST

Once every month, when performing the Coin SW Test, simultaneously check the following:

- Does the Coin Meter count satisfactorily?
- Does the coin drop into the Cashbox correctly?
- Is the coin rejected when inserted while keeping the Reject Button pressed down?

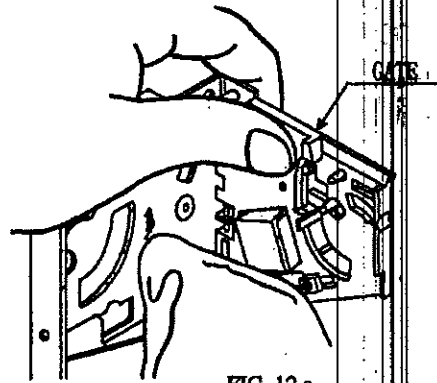

FIG. 12 a

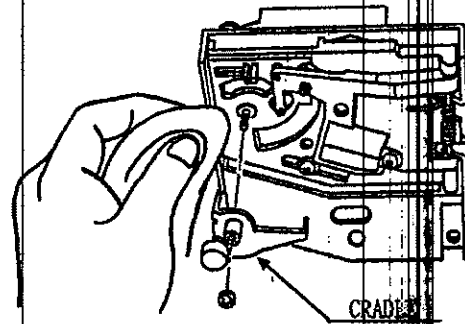
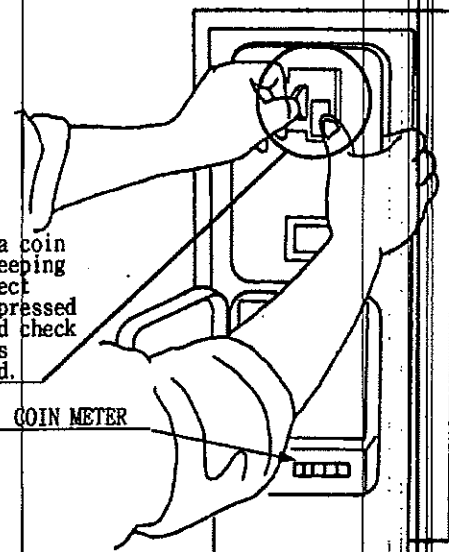

FIG. 12 b



Insert a coin while keeping the Reject Button pressed down and check if it is rejected.

FIG. 12 c

13. PROJECTOR



Since the Projector has been adjusted at the time of shipment, avoid making further adjustments without good reason.



The Projector is subject to color deviation due to Convergence deviation caused by the geomagnetism at the installation location and peripheral magnetic field. After the installation of machine, and before commencing operation, check for Convergence deviation and if deviated, make adjustments.

Fine adjustments are stored in the Projector. Pressing the Fine Adjustment SW (Convergence Adjustment) results in entering the Fine Adjustment mode, and this may cause the stored fine adjustment to be changed. During work other than for adjustment, should you touch the Fine Adjustment SW by mistake, immediately turn the power off by using the main SW and then turn it back on again. If any distortion or color deviation is found in the test mode and adjustments are needed, use the specified Adjustment knob, or perform the adjustment by remote control. In relation to this type of Projector, there are 2 different manufacturers, i. e., Mitsubishi and Toshiba. The adjustment method differs depending on the specific maker.

13-1 CLEANING THE SCREEN



Since the Projector screen is susceptible to damage, pay careful attention to its handling. When cleaning, refrain from using water or volatile chemicals.

When the screen surface becomes dirty with dust, etc., clean it by using a soft cloth such as gauze. When water, and volatile chemicals such as benzine, thinner, etc., spill on the screen surface, it may be subject to damage, therefore, do not use them. Also, since the surfaces are susceptible to damage, refrain from rubbing them with a hard material or using a duster.

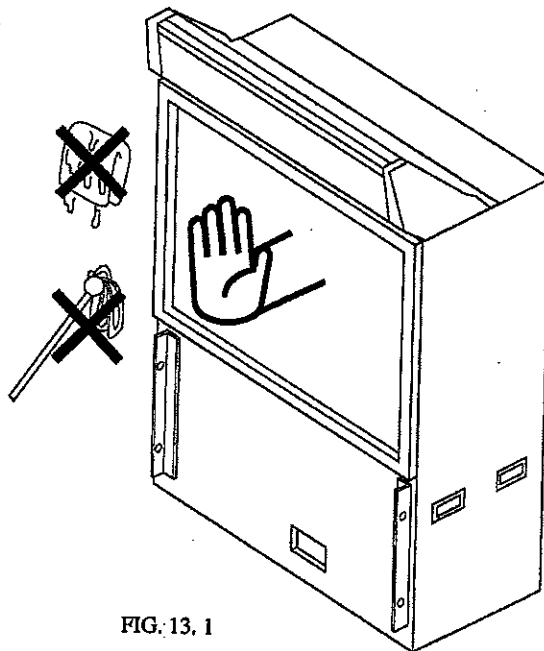

FIG. 13.1

13-2 MITSUBISHI PROJECTOR

When adjusting MITSUBISHI PROJECTOR, use the Remote Control.

STOP

IMPORTANT

- Although Remote Control Buttons other than those specified below do not function even if pressed during Convergence Adjustment, do not press them during adjustment work so as to avoid causing malfunctioning.
- Operate the Remote Control towards the PTV screen. If directed other than to the PTV screen, the Remote Control does not function.

STATIC CONVERGENCE ADJUSTMENT

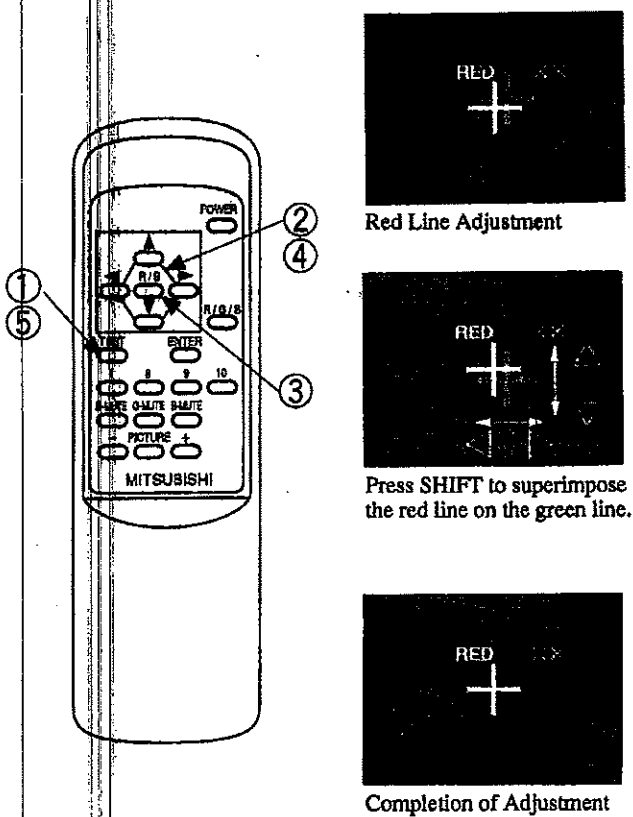

- ① Press the TEST KEY to have the red line adjustment screen appear.
- ② Superimpose the red cross on the green cross at the center of the screen. Move the red cross to the left, right, up and down respectively with ◀▶▲ and ▼ of the Remote Control. When the red cross is superimposed on the green cross, the green cross turns into yellow or white.
- ③ Press the R/B Key to have the blue line adjustment screen appear. Each time R/B Key is pressed, the red line and blue line will be alternated.
- ④ In the manner similar to ② above, press each key to superimpose the blue cross on the green cross. When it is superimposed, the cross in the center will become white.
- ⑤ Press the TEST Key to exit from the adjustment mode.

During STATIC CONVERGENCE Adjustment Mode, if no action is taken within 5 minutes, the Adjustment Mode will be exited automatically.

ADJUSTMENT MODE

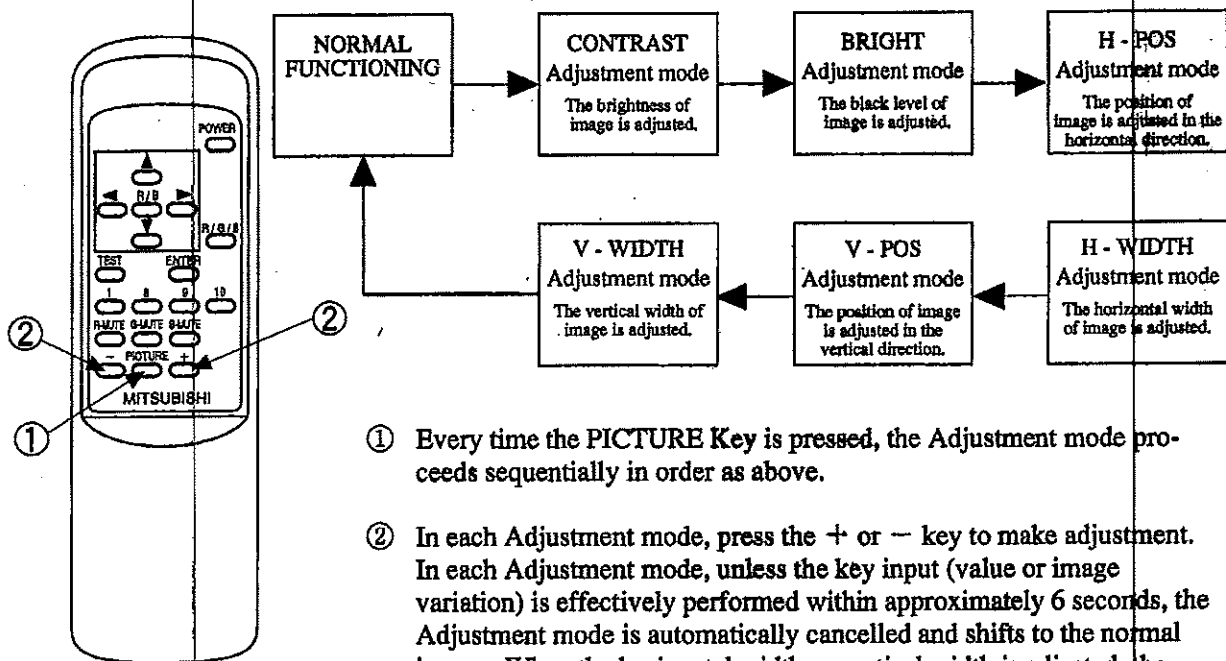

- ① Every time the PICTURE Key is pressed, the Adjustment mode proceeds sequentially in order as above.
- ② In each Adjustment mode, press the + or - key to make adjustment. In each Adjustment mode, unless the key input (value or image variation) is effectively performed within approximately 6 seconds, the Adjustment mode is automatically cancelled and shifts to the normal image. When the horizontal width or vertical width is adjusted, the convergence is automatically corrected (auto adjuster functioning).

13-3 TOSHIBA PROJECTOR

When adjusting the Projector, direct the Remote Control's light emitting portion towards the Projector Screen.

REMOTE CONTROL BUTTONS

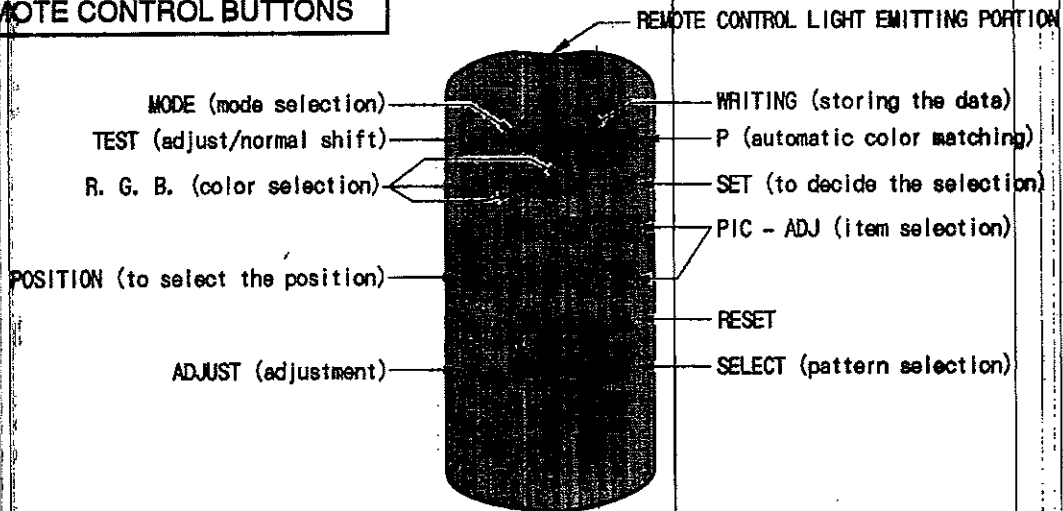

AUTOMATIC COLOR MATCHING

The Projector may be subject to color deviations affected by earth magnetism, the building steel frames, etc. When the Projector is initially installed or the Projector's installation position is changed, have the color matching performed automatically.

- ① Keep pressing the P button (red) for approximately 3 seconds to have the ensuing movements performed automatically.

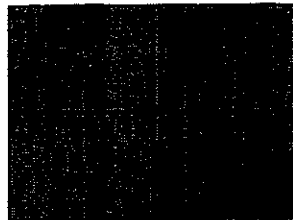
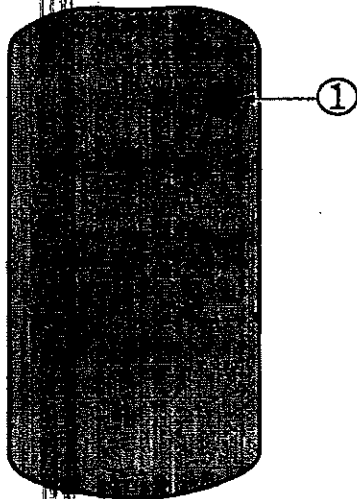

The Projector will shift to the color deviation correction mode from the game mode, with the green cross pattern appearing on the screen.

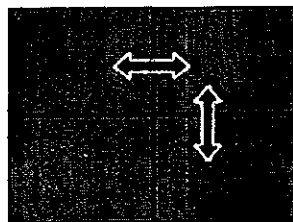

The cross pattern moves up/down and right/left to start the movement of searching the correct screen position and inclination.

When the green cross pattern movements are finished, similar detection is performed sequentially in order of red and then blue cross movements. After detecting by green, red and blue cross movements, the game mode returns with the color deviation status being corrected.

- Although very rarely, the TRY AGAIN error display in red may appear. At this time, press the P button (red) for approximately 3 seconds. Even after the above operation is repeated, if the error condition still exists, then the display shifts to PLEASE ADJ. In this case, the auto color matching function can not be used. Contact the place of contact herein stated or where the product was purchased from.
- If the automatic color matching indicates an error, color matching can manually be performed. Refer to CONVERGENCE ADJUSTMENT (manual color matching).

ADJUSTING THE ON-SCREEN CONTRAST

Although the on-screen picture quality has been adjusted at the time of shipment from the factory, the on-screen contrast can be readjusted if desired. When the Game Board is replaced, readjustment may be necessary. Changing the CONTRAST causes the light and shade of the on-screen images to be changed.

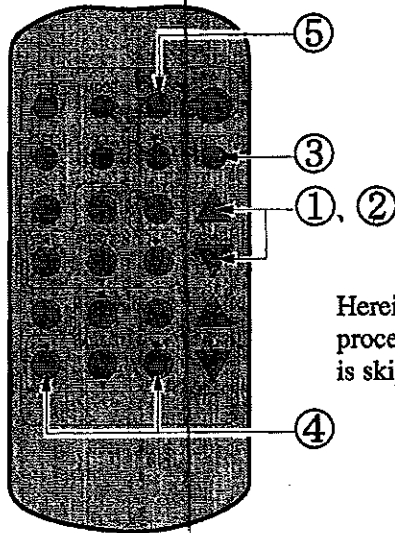

Herein, procedure ② is skipped.

① Press either ▲ or ▼ PIC - ADJ button.

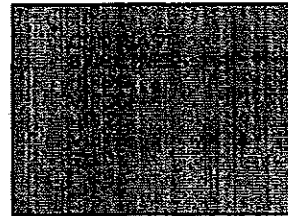

The on-screen menu will have one item in purple and 6 items in white.

② Choose CONTRAST by using either ▲ or ▼ PIC - ADJ button.

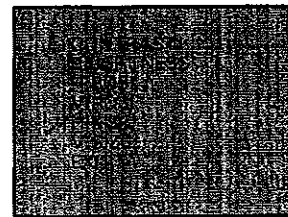

Have CONTRAST displayed in purple. Since CONTRAST is selected initially, no particular operation is required in this case.

③ Press the SET button (to decide selection).

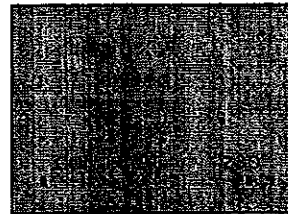

When the selection of the CONTRAST adjustment mode is decided, the adjustment data scale bar appears on the screen.

④ Make adjustment by using either ◀ or ▶ ADJUST button.

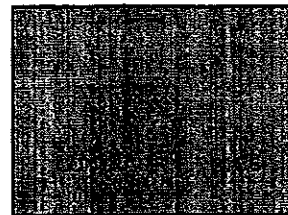

As the Cursor is moved, the adjustment data value changes. Make adjustment so as to obtain the desired on-screen contrast status.

⑤ Press the WRITING button (for storing and finish).

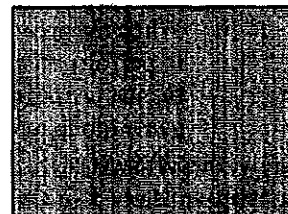

The WRITING display appears and the adjustment data is stored.

- When discontinuing the adjustment, choose EXIT from the menu at the stage of procedure ② and press the SET button.
- To continue adjusting other menu items, repeat procedure ②~④.
- Unless the adjustment data is stored, the data in the adjusted status will be erased at the time the power is turned off and the pre-adjustment status will remain when the power is turned on next time.

ADJUSTING THE SCREEN BRIGHTNESS

Although the on-screen picture quality has been adjusted at the time of shipment from the factory, readjustment can be made if desired. When the Game Board is replaced, readjustment may be necessary. Changing the BRIGHTNESS causes the brightness of the on-screen images of black portions to be changed.

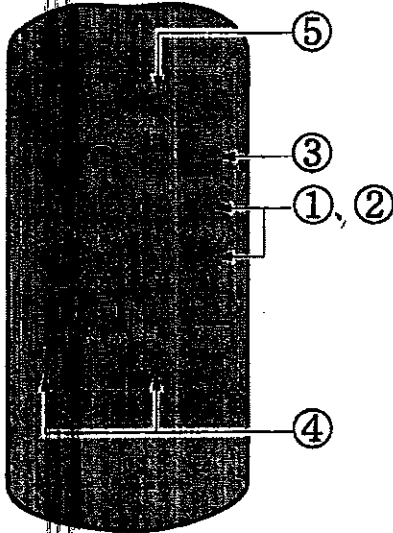

- ① Press either ▲ or ▼ PIC - ADJ button.

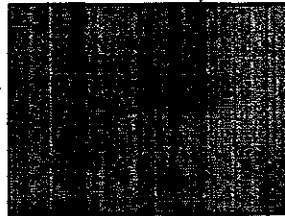

The on-screen menu will have one item in purple and 6 items in white.

- ② Choose BRIGHTNESS by using either ▲ or ▼ PIC - ADJ button.

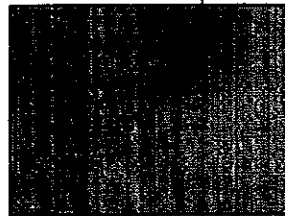

Have the BRIGHTNESS displayed in purple.

- ③ Press the SET button (to decide selection).

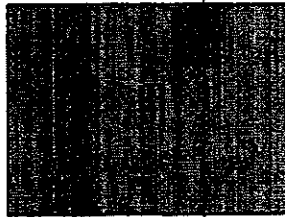

When the selection of the BRIGHTNESS adjustment mode is decided, the adjustment data scale bar appears on the screen.

- ④ Make adjustment by using either ◀ or ▶ ADJUST button.

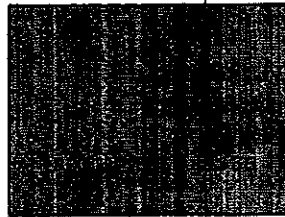

As the Cursor is moved, the adjustment data value changes. Make adjustment so as to obtain the desired on-screen brightness status.

- ⑤ Press the WRITING button (for storing and finish).

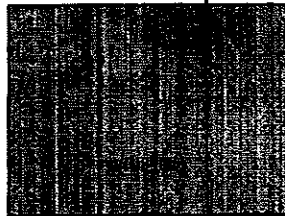

The WRITING display appears and the adjustment data is stored.

- When discontinuing the adjustment, choose EXIT from the menu at the stage of procedure ② and press the SET button.
- To continue adjusting other menu items, repeat procedure ②~④.
- Unless the adjustment data is stored, the data in the adjusted status will be erased at the time the power is turned off and the pre-adjustment status will remain when the power is turned on next time.

ADJUSTING THE ON-SCREEN DISPLAY POSITION

Although the on-screen display position (H. POSI, V. POSI) has been adjusted at the time of shipment from the factory, readjustment can be made if desired. When the Game Board is replaced, readjustments may be necessary.

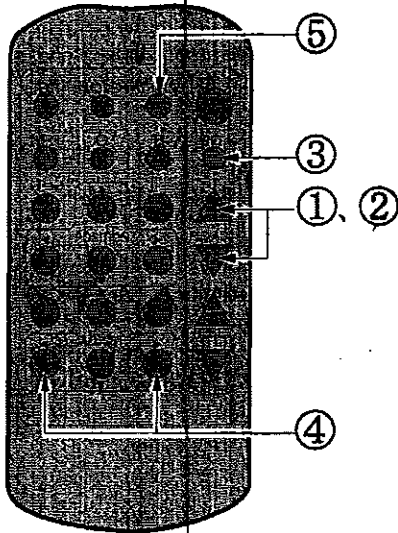

① Press either ▲ or ▼ PIC - ADJ button.

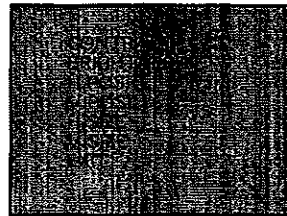

The on-screen menu will have one item in purple and 6 items in white.



② Choose H. POSI or V. POSI by using either ▲ or ▼ PIC ADJ button.

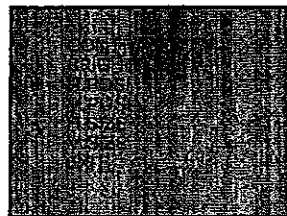

Have the H. POSI or V. POSI displayed in purple. The Figure shows the status in which H. POSI is selected.



③ Press the SET button (to decide selection).

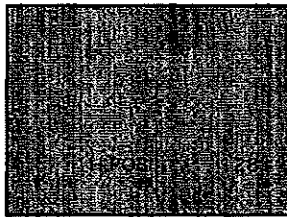

When the selection of the H. POSI or V. POSI is decided, the adjustment data scale bar appears on the screen.



④ Make adjustment by using either ◀ or ▶ ADJUST button.

When making adjustments in vertical directions, also use either ◀ or ▶ ADJUST button.

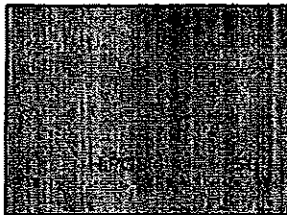

As the Cursor is moved, the adjustment data value changes. Make adjustment so as to obtain the desired on-screen position status.



⑤ Press the WRITING button (for storing and finish).

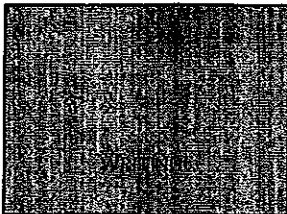

The WRITING display appears and the adjustment data is stored.

- When discontinuing the adjustment, choose EXIT from the menu at the stage of procedure ② and press the SET button.
- To continue adjusting other menu items, repeat procedure ②~④.
- Unless the adjustment data is stored, the data in the adjusted status will be erased at the time the power is turned off and the pre-adjustment status will remain when the power is turned on next time.

ADJUSTING THE SCREEN SIZE

Although the on-screen size (H. SIZE, V. SIZE) has been adjusted at the time of shipment from the factory, readjustment can be made if desired. When the Game Board is replaced, readjustments may be necessary.

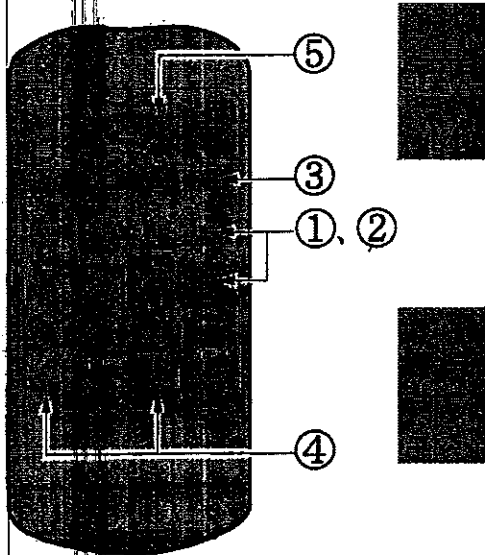

- ① Press either ▲ or ▼ PIC - ADJ button.

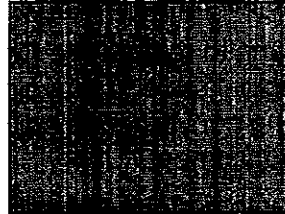

The on-screen menu will have one item in purple and 6 items in white.

- ② Choose H. SIZE or V. SIZE by using either ▲ or ▼ PIC - ADJ button.

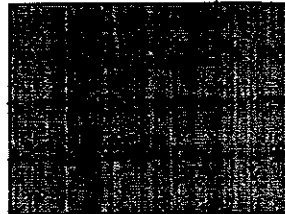

Have the H. SIZE or V. SIZE displayed in purple. The Figure shows the status in which H. SIZE is selected.

- ③ Press the SET button (to decide selection).

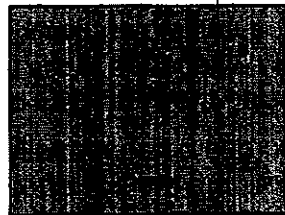

When the selection of the H. SIZE or V. SIZE adjustment mode is decided, the adjustment data scale bar appears on the screen.

- ④ Make adjustment by using either ◀ or ▶ ADJUST button.

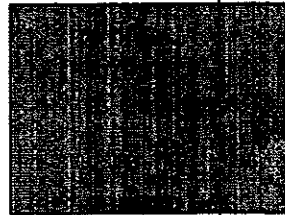

As the Cursor is moved, the adjustment data value changes. Make adjustment so as to obtain the desired on-screen position status.

When making adjustments in vertical directions, also use either ◀ or ▶ button.

- ⑤ Press the WRITING button (for storing and finish).

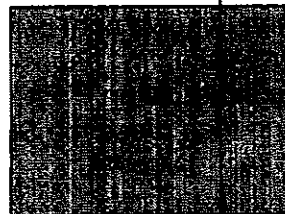

The WRITING display appears and the adjustment data is stored.

- When discontinuing the adjustment, choose EXIT from the menu at the stage of procedure ② and press the SET button.
- To continue adjusting other menu items, repeat procedure ②~④.
- Unless the adjustment data is stored, the data in the adjusted status will be erased at the time the power is turned off and the pre-adjustment status will remain when the power is turned on next time.

CONVERGENCE ADJUSTMENT (manual color matching)



To avoid circuitry malfunctioning due to electrical load increase, never utilize CONVERGENCE ADJUSTMENT (Line Convergence Adjustment in particular) for adjusting screen size changes.

There is no means to restore the Convergence Adjustment data once stored, to its original state. To avoid changing the screen size by erroneously using convergence adjustment, do not perform the green Line Convergence Adjustment.

As such, be sure to perform the adjustment work from this page onward by the Technical staff and the location's Maintenance Personnel who are well versed in such adjustment work. In the Static Convergence Adjustments, if satisfactory adjustments can not be performed, do not make another convergence adjustments inadvertently. Contact the office herein stated or where the product was purchased from.



- To avoid making the adjustment work ineffective, do not press the RESET button during adjustment.
- To discontinue adjustment work, keep pressing the TEST button for approximately 3 seconds at the stage before storing the adjustment data by pressing the WRITING button.
- Should the screen be abnormally disturbed by noise due to static electricity, etc., turn the power off without storing the adjustment data.
- Pressing the ▲ or ▼ PIC - ADJ button in the Convergence Adjustment mode status will display the Adjustment Menu shown right. Do not utilize this Adjustment Menu as this is the one applied at the factory.

Adjusting this menu causes the Customer's adjustment range to be deviated.

Should the menu shown right be displayed by mistake, first choose EXIT by using either ▲ or ▼ PIC - ADJ button and then press the SET button.

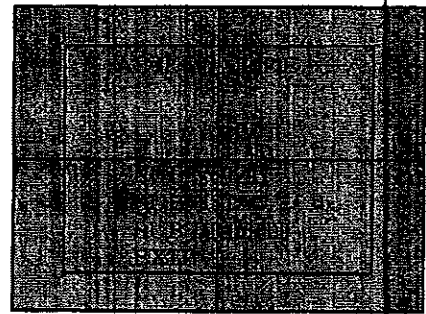

Adjustment menu used in the factory.

STATIC CONVERGENCE ADJUSTMENT

In the static convergence adjustment, each of red and blue images is comprehensively moved to and superimposed on the green color. If automatic color matching function is not sufficiently satisfactory, perform this adjustment. Be sure to perform automatic color matching before starting the above adjustment.

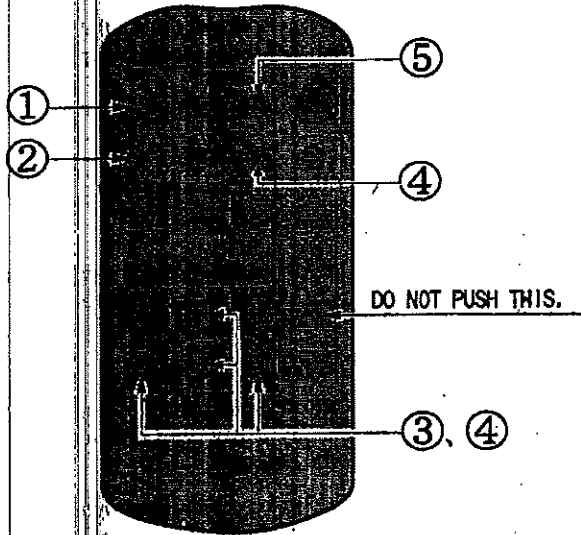

When either of ② ④ COLOR SELECT buttons (R, B) is pressed, if the color desired to be adjusted disappears, press that particular button again. For example, if the red color needs to be adjusted again at the stage of ④, the R button need to be pressed twice.

- ① Keep pressing the TEST button for approximately 3 seconds.

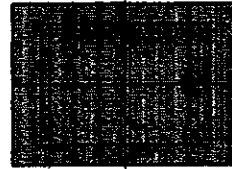

The screen will change to ADJUST mode from the Game mode because the green test pattern to be displayed on the screen.

- ② Press the R button to have the red adjustment mode.



The red test pattern is added to the display. The frame color turns red and this signifies the red adjustment mode.

- ③ Make adjustment by using the ▲ ▼ ◀ ▶ ADJUST buttons.

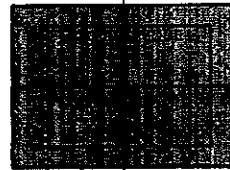

Make adjustment so as to have red superimposed on green. When red is superimposed on green, the color becomes yellow.

- ④ Press the B button to have the blue adjustment mode.

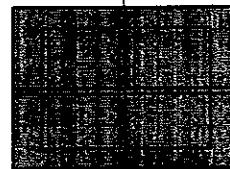

Similarly as in the case of red, adjust the blue color. When green, red, and blue are superimposed, the color becomes white.

- ⑤ Press the WRITING button (for storing and finish).

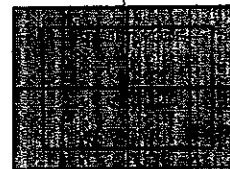

The WRITING display appears and the adjustment data is stored. After the data is stored, the Game mode returns.

POINT CONVERGENCE ADJUSTMENT

In the POINT CONVERGENCE adjustment, each of red, green and blue images is partially moved for color matching. The adjustment may be necessary when the Game Board is replaced or changed, or screen size is changed. Be sure to perform automatic color matching before starting the adjustment.

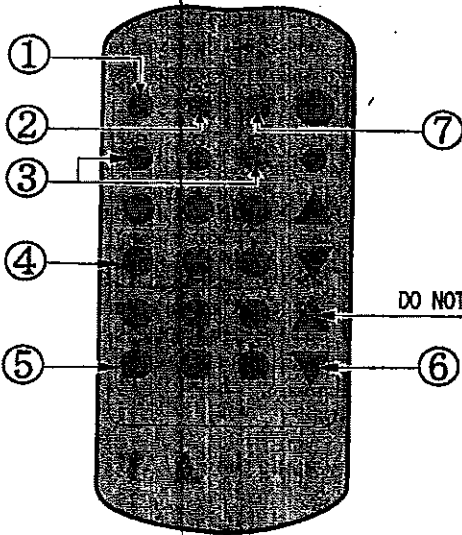

Note 1 When the MODE button is repeatedly pressed, the adjustment modes will circulate as follows:

STATIC ADJUSTMENT MODE
 ↓
 LINE ADJUSTMENT MODE
 ↓
 POINT ADJUSTMENT MODE
 ↑

Note 2 When either of the COLOR SELECT buttons (R, B) is pressed, if the desired color to be adjusted disappears, press that particular button again.

Note 3 By repeatedly pressing the SELECT button, only the Projector's TEST pattern screen and the screen superimposing the Game Board Test pattern can be alternately displayed.

- Keep pressing the TEST button for approximately 3 seconds.

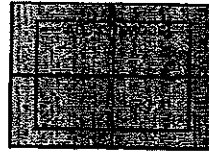

The screen changes to ADJUST mode from the Game mode and displays the green test pattern.

- Press the MODE button twice to have the POINT ADJUSTMENT mode. Note 1

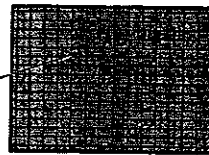

The crosshatch test pattern appears and the MARKER indicating the adjustment point is displayed.

- Using either R or B button, select the desired color to be adjusted. Note 2 By using the G button, the green color can also be selected.

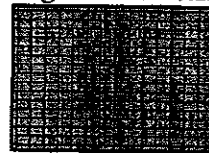

The selected color is displayed by superimposing on green. The MARKER will be in the color selected.

- By using the ▲ ▼ ◀ ▶ ADJUST buttons, move the MARKER to the position to be adjusted.

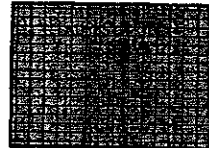

The MARKER moves in the direction of the button's arrow. However, the movable point is predetermined.

- Make adjustment by using the ▲ ▼ ◀ ▶ ADJUST buttons.

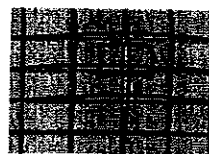

Although the direct vicinity of the MARKER's center moves most conspicuously, make adjustment by paying attention to the periphery area also. Shown left is the magnified MARKER periphery.

- Press the SELECT button as necessary to superimpose Game Board images. Note 3



If the test pattern is not displayed in the periphery of the screen, adjustments can be made by pressing the SELECT button to superimpose the test pattern and the Game Board's CRT test screen.

- Press the WRITING button (for storing and finish).

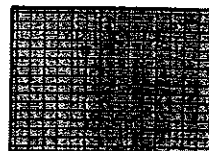

WRITING is displayed and the adjustment data is stored. After the data is stored, the Game Board screen returns.

LINE CONVERGENCE ADJUSTMENT

In the **LINE CONVERGENCE ADJUSTMENT**, the adjustment point of the column line (vertical) or row line (horizontal) is comprehensively moved for color matching. It is convenient to utilize this adjustment when the color of the column line or row line is uniformly deviated.

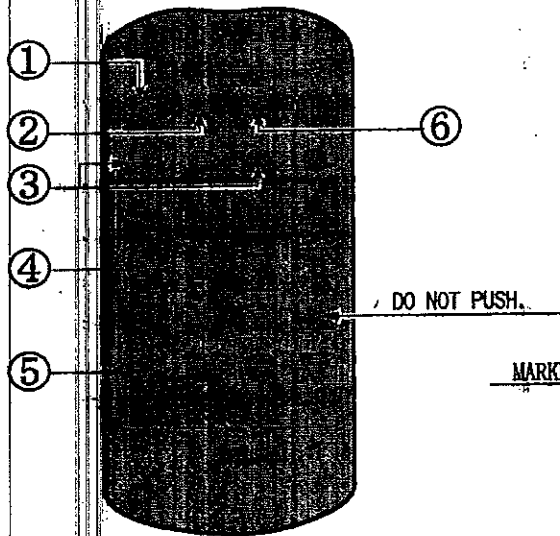

- ① Keep pressing the TEST button for approximately 3 seconds.

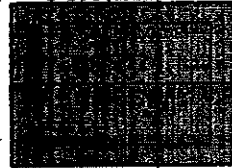

The screen changes to **ADJUST** mode from the Game Board mode and displays the green test pattern.

- ② Press the MODE button once to have the **POINT ADJUSTMENT** mode. Note 1

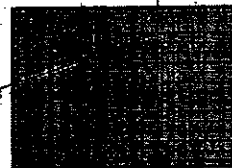

The crosshatch test pattern appears and the vertically long **MARKER** is shown.

- ③ Using either R or B button, select the desired color to be adjusted. Note 2 Although the green color can also be selected by using the G button, to avoid the screen size change adjustment, do not choose green.



The selected color is displayed by superimposing on green. The **MARKER** will be in the color selected.

- ④ By using the ▲ ▼ ◀ ▶ POSITION buttons, move the **MARKER** to the position to be adjusted.



Use the ◀ ▶ buttons to select the column line, and the **MARKER** moves in the right/left direction. However, the movable range is predetermined.

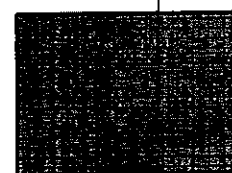

Use the ▲ ▼ buttons to select the row line and the **MARKER** moves in the up/down direction. However, the movable range is predetermined.

- ⑤ Make adjustment by using the ▲ ▼ ◀ ▶ ADJUST buttons.

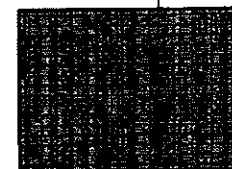

The selected column line or row line (shown left is the column line) can be moved in the desired up/down or right/left directions as applicable.

- ⑥ Press the **WRITING** button (for storing and finish).

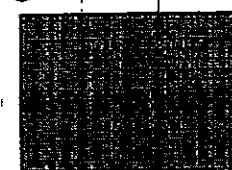

WRITING is displayed and the adjustment data is stored. After the data is stored, the Game Board screen returns.

Note 1 When the MODE button is repeatedly pressed, the adjustment modes will circulate as follows:

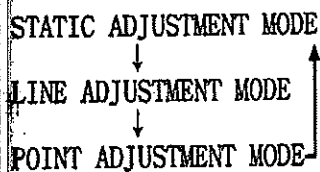

Note 2 When either of the COLOR SELECT buttons (R, B) is pressed, if the desired color to be adjusted disappears, press that particular button again.

14. REPLACEMENT OF FLUORESCENT LAMP



- When performing the work, be sure to turn power off. Working with power on can cause an electric shock or short circuit accident.
- The Fluorescent Lamp, when it gets hot, can cause burns. Be very careful when replacing the Fluorescent Lamp.



To perform work safely and securely, be sure to prepare a step which is in a secure and stable condition. Working without using a step can cause a violent falling down accidents.

- ① Remove the 3 screws which secure the Holder on the upper part of Billboard.
- ② To replace the Fluorescent Lamp (32W), pull the Billboard upward.

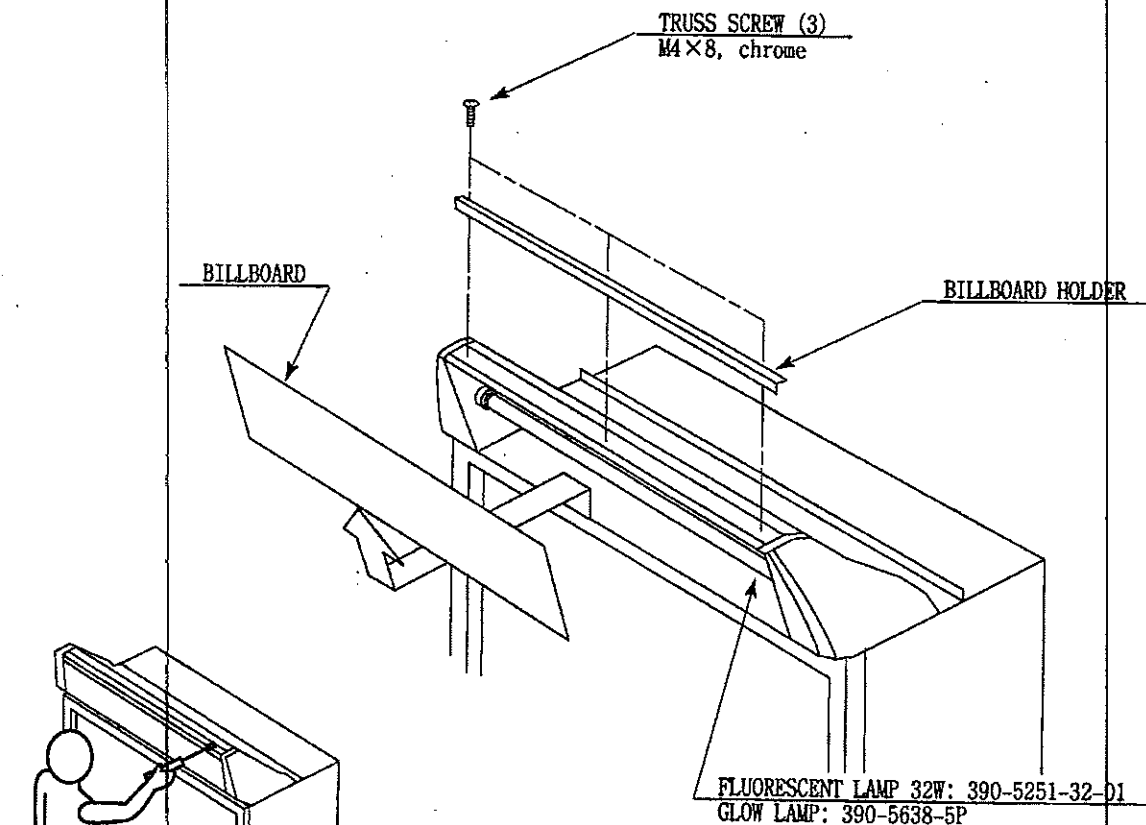
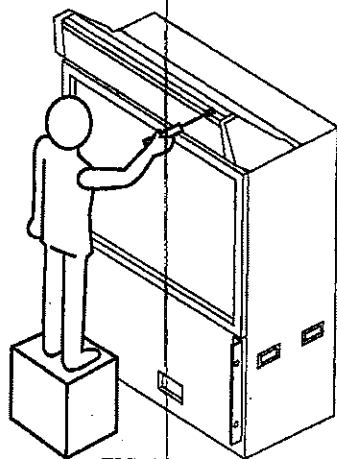

FIG. 14 a



When performing work,
prepare a step.

15. PERIODIC INSPECTION TABLE

The items listed below require periodic check and maintenance to retain the performance of this machine and to ensure safe business operation.



- Be sure to check once a year to see if Power Cords are damaged, the plug is securely inserted, dust is accumulated between the Socket Outlet and the Power Plug, etc. Using the product with dust as is accumulated can cause a fire or electric shock.
- Periodically once a year, request the place of contact herein stated or the Distributor, etc. where the product was purchased from, as regards the interior cleaning. Using the product with dust as is accumulated in the interior without cleaning can cause a fire or accident. Note that cleaning the interior parts can be performed on a pay-basis.

TABLE 15

ITEMS	DESCRIPTION	PERIOD	REFERENCE
CABINET	Check Adjuster's contact with the floor.	Daily	3
HANDLEBAR	Check VOLUME VALUE.	Monthly	9-12
	Check SW.	Monthly	9-5
	Check GEAR engagement.	Tri-monthly	10
	Greasing	Semi-yearly	10-4
BIKE MECHA	Check Safety Rubber	Daily	3
	Check VOLUME VALUE.	Monthly	9-12
	Check GEAR engagement.	Tri-monthly	11
	Greasing GEAR portions.	Semi-yearly	11-2
COIN CHUTE TOWER	Check COIN SWes.	Monthly	9-1
	Coin insertion test.	Monthly	12
	COIN SELECTOR cleaning.	Tri-monthly	12
PROJECTOR	Check adjustments.	Monthly or when moving.	9, 13
	SCREEN cleaning.	Weekly	13-1
POWER PLUG	Inspection and cleaning	Annually	See above.
INTERIOR	Cleaning		
Cabinet surfaces	Cleaning	As occasion arises.	See below.

CLEANING THE CABINET SURFACES

If the Cabinet is badly stained, use a cloth which is dipped in the chemical detergent liquid diluted with water and then squeezed dry. Do not use thinner, benzine, alcohol or chemical dust cloth as these can damage the Cabinet surfaces.

16. TROUBLESHOOTING



- In order to prevent an electric shock, be sure to turn power off before performing work by touching the interior parts of the product.
- Be careful so as not to damage wirings. Damaged wiring can cause an electric shock or short circuit accident.

For troubleshooting, first check the connection of wiring connectors.

TABLE 16 a

PROBLEMS	CAUSE	COUNTERMEASURES
When the main SW is turned ON, the machine is not activated.	<p>The power is not ON.</p> <p>Incorrect power source/voltage.</p> <p>The CIRCUIT PROTECTOR functioned due to momentary overcurrent.</p> <p>Power supply unit fuse is blown due to momentary overload.</p>	<p>Firmly insert the plug into the outlet.</p> <p>Make sure that the power supply/voltage are correct.</p> <p>After eliminating the cause of overload, have the Circuit Protector of the AC Unit restored.</p> <p>After eliminating the cause of overload, replace the fuse (FIG. 16 b, PHOTO 16). 514-5036-7000 FUSE 6.4 ϕ \times 30 7000mA 125V</p>
Although sound is emitted, image does not appear, nor does the Billboard light up.	Connection fault between Front Cabinet and PTV.	Check the connection of the 3p white connector. (See [2], Section 6.)
Although sound is emitted and Billboard is lit, the image does not appear.	Connection failure between Front Cabinet and PTV.	Check the connection of BNC connectors (R, G, B, and SYNC). (See [2], Section 6.)

CIRCUIT PROTECTOR



After removing the cause of the functioning of the Circuit Protector, reinstate the Circuit Protector. Depending on the cause of the functioning, using the Circuit Protector as is without removing the cause could result in generation of heat and a fire.

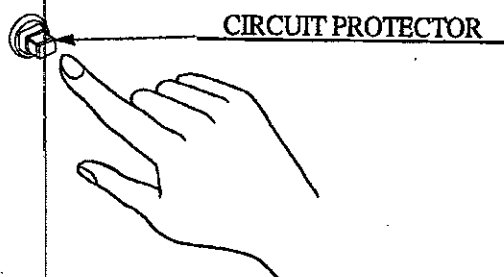

Functions due to the activation of bimetal. To restore the function, wait for approximately one minute or longer until the bimetal cools off. (Press the Button.)

TABLE 16 b

PROBLEMS	CAUSE	COUNTERMEASURES
The color on the PTV screen is not correct.	Connection failure between Front Cabinet and PTV. Incorrect monitor adjustment.	Check if each of BNC cables is correctly connected. Make appropriate adjustments.
PTV screen has a color deviation.	Affected by the magnetic field changes of the periphery, such as other machines, location building's steel frames, etc.	Make convergence adjustments (see Sec. 13).
The on-screen image of the monitor sways and or shrinks.	Incorrect power source/voltage. In sufficient power capacity.	Make sure that the power supply/voltage are correct. Secure sufficient power capacity.
The image is displayed, but the Billboard does not light up.	Connection failure between BILLBOARD and PTV. Fluorescent Lamp needs replacement.	Check the connection of the 3p white connector (see [1], Sec. 6). Replace Fluorescent Lamp (see Sec. 14).
Sound is not emitted.	Sound volume adjustment is not correct. Sound related Board and Memory are irregular.	Adjust the SWITCH UNIT's sound adjustment volume (control) (9-1). Perform sound and memory test (9-7).
After game start, the Locking Mechanism is not unlocked.	Connection failure between Front Cabinet and Rear Cabinet. Incorrect Cabinet Type Setting	Check if all of the connectors are securely connected (see [2], Sec. 6). Correct Cabinet Type setting. (9-9)
Operation is unsatisfactory.	Poor V. R. setting. V. R. deviation or malfunctioning. Poor mesh of V.R. GEAR. Spring failure due to secular change of Accelerator and Brake mechanism.	Perform Volume setting. (9-12) Adjust or replace the V. R. (see Sec. 10, 11). Adjust GEAR mesh (see Sec. 10, 11). Replace the spring.
Shift operation is not satisfactory at the time of Manual Transmission.	Shift SW malfunctioning.	Replace SW.
NETWORK check will not finish.	Communication cable's connection failure. Communication play setting is wrong.	Check for communication cable disconnection. Check if communication cable is correctly connected. (19-2) Correctly set in the test mode. (19-3)
Communication play is not possible.	Communication cable's connection failure. Communication play setting is wrong.	Check for communication cable disconnection. Check if communication cable is correctly connected. (19-2) Correctly set in the test mode. (19-3)

REPLACEMENT AND ADJUSTMENT OF FUSE



- In order to prevent an electric shock and short circuit, be sure to turn power off before performing work by touching the interior parts of the product.
- Be sure to use fuses meeting specified rating. Using fuses exceeding the specified rating can cause a fire or electric shock.
- After eliminating the cause of the blowing of fuse, replace the fuse. Depending on the cause of fuse blowing, using the fuse as is blown can cause generation of heat resulting in a fire.

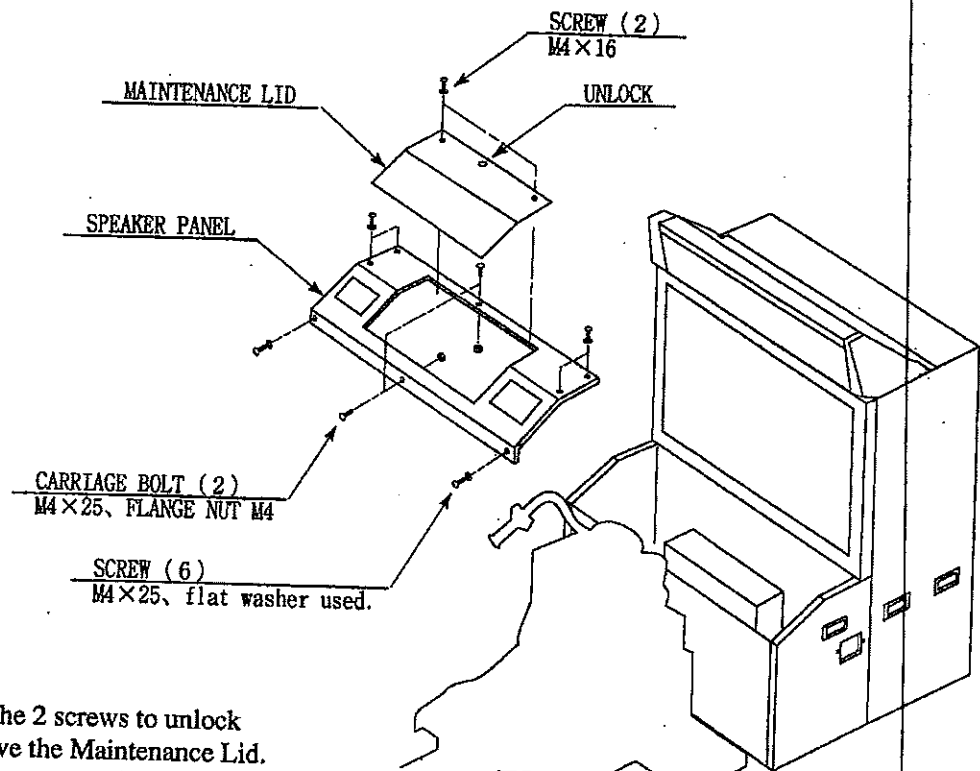

FIG. 16

- ① Remove the 2 screws to unlock and remove the Maintenance Lid.
- ② When the Maintenance Lid is removed, the 6p white connector appears. Disconnect the connector.
- ③ Remove the 6 screws which secure the Speaker Panel of the Front Cabinet.
- ④ After the Maintenance Lid has been removed as above, remove the nut and the 2 carriage bolts from inside.
- ⑤ Remove the Speaker Panel.
- ⑥ The fuse is positioned on the XFMR Base.

FUSE 7A
514-5036-7000

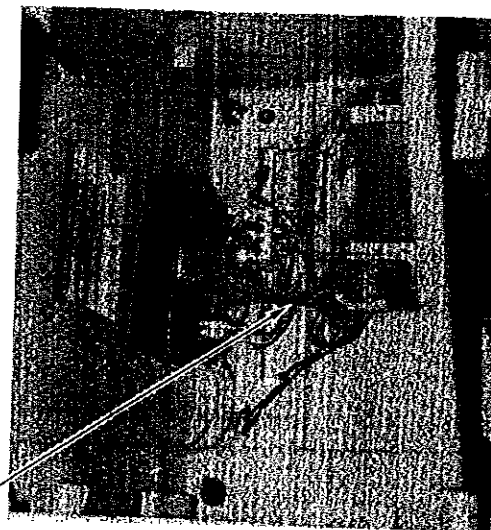

Photo 16

17. GAME BOARD



- In order to prevent electric shock and short circuit accidents, be sure to turn power off before performing work by touching the interior parts of the product.
- Be careful so as not to damage wirings. Damaged wiring can cause a fire or electric shock and short circuit accidents.
- Do not expose the Game BD, etc. without a justifiable reason. Exposed Game BD, etc. can cause electric shock accidents and malfunctioning.



- The electronic parts on the IC Board could be damaged due to human body's static electricity. Before performing IC Board related work, be sure to discharge physically accumulated statics by touching grounded metallic surfaces.
- When asking for the replacement or repair of the product's Game Board (MODEL 3 BOARD), be sure to put the Game Board together with the Shield Case in a Carton Box. Otherwise, the request is not acceptable.

17-1 REMOVING THE GAME BOARD

- 1 Turn power off.
- 2 Remove the 2 screws which secure the Maintenance Lid.
- 3 Unlock and remove the Maintenance Lid from the Front Cabinet.

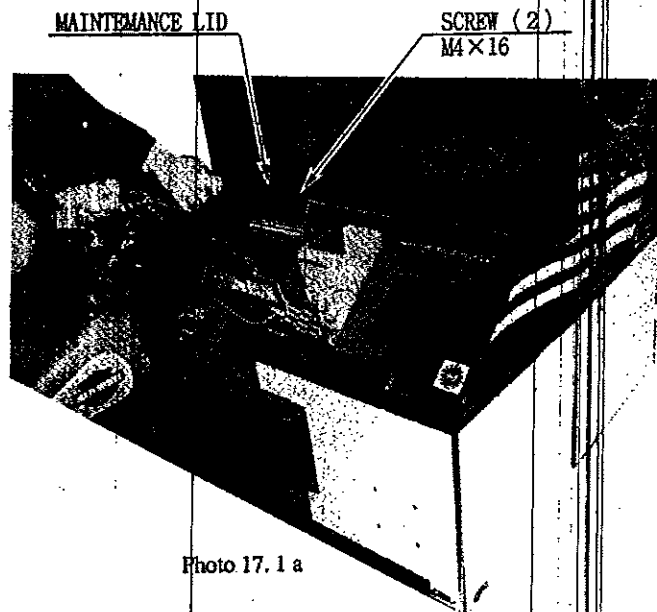

Photo 17.1 a

- 4 Remove the Maintenance Lid, and the Shield Case appears. Remove all of the connectors connected to the Shield Case.



Photo 17.1 b

- ⑤ Remove the screw securing the wooden base on which the Shield Case is mounted.

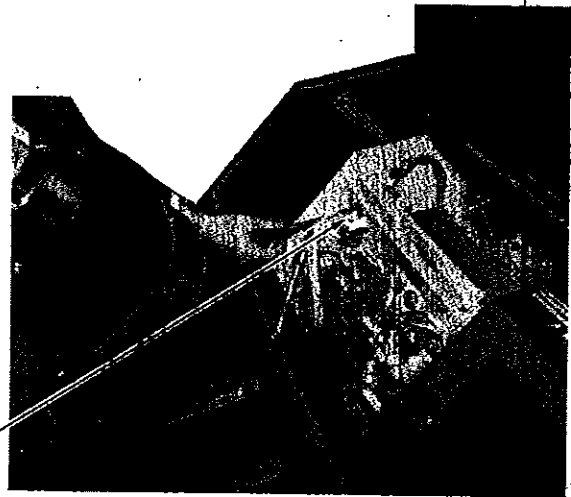

SCREW (2)
M4×35,
w/flat & spring washers

Photo 17.1 c

- ⑥ Remove the wooden base from the Front Cabinet together with the Shield Case (as is mounted).
- ⑦ Take out the 3 screws, remove Shield Case Lid, and the Game Board appears.

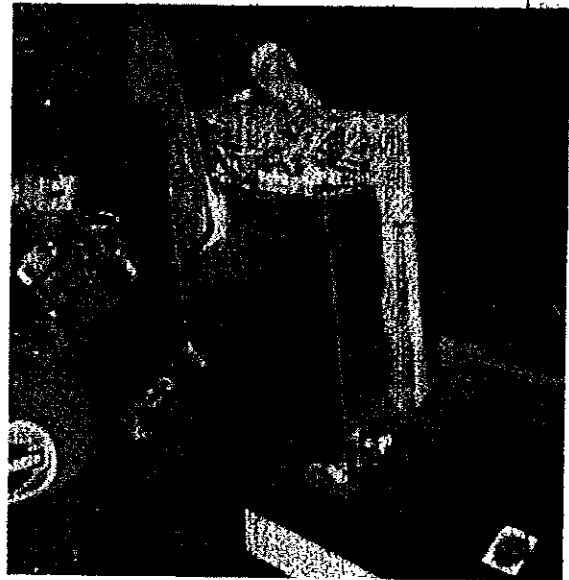

Photo 17.1 d

SCREW (3)
M4×8,
w/flat & spring washers

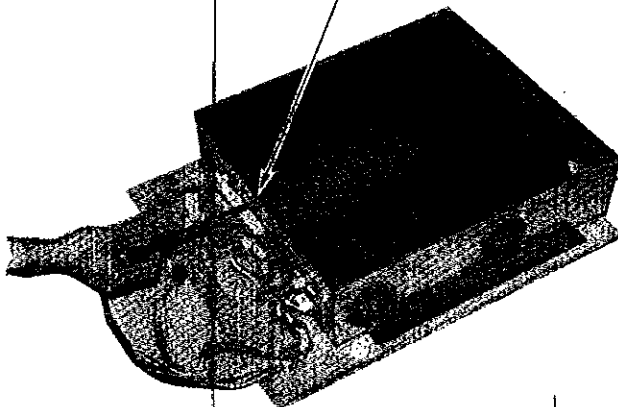

Photo 17.1 e

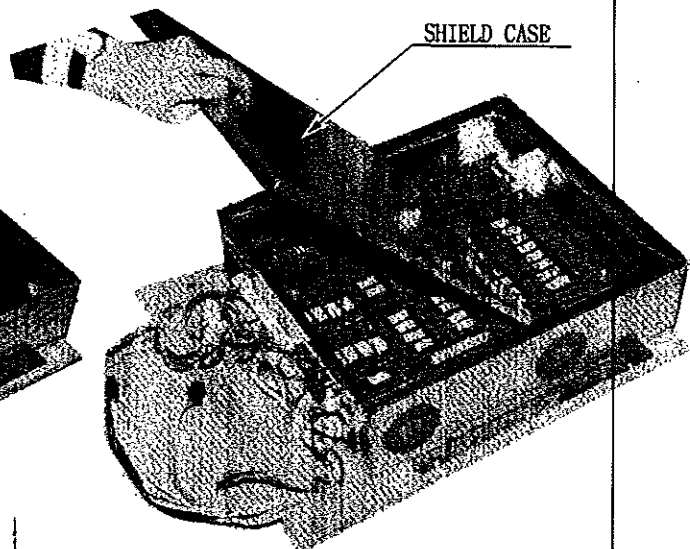

Photo 17.1 f

17-2 COMPOSITION OF GAME BOARD

GAME BD HARLEY DAVIDSON (833-13325)

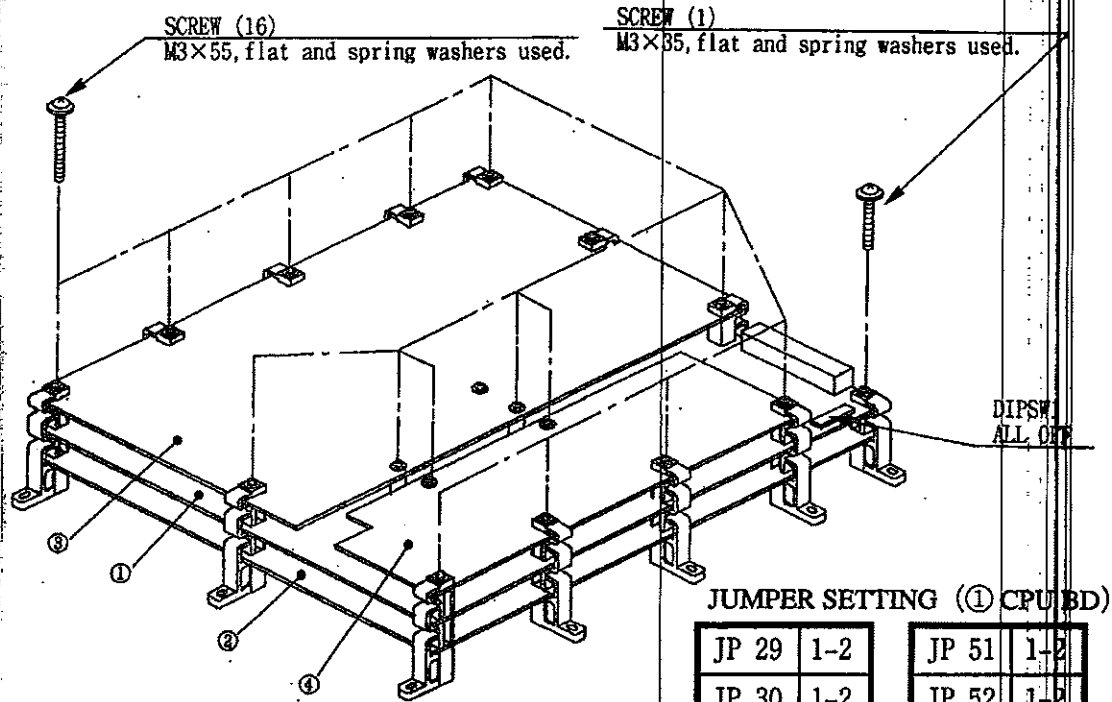
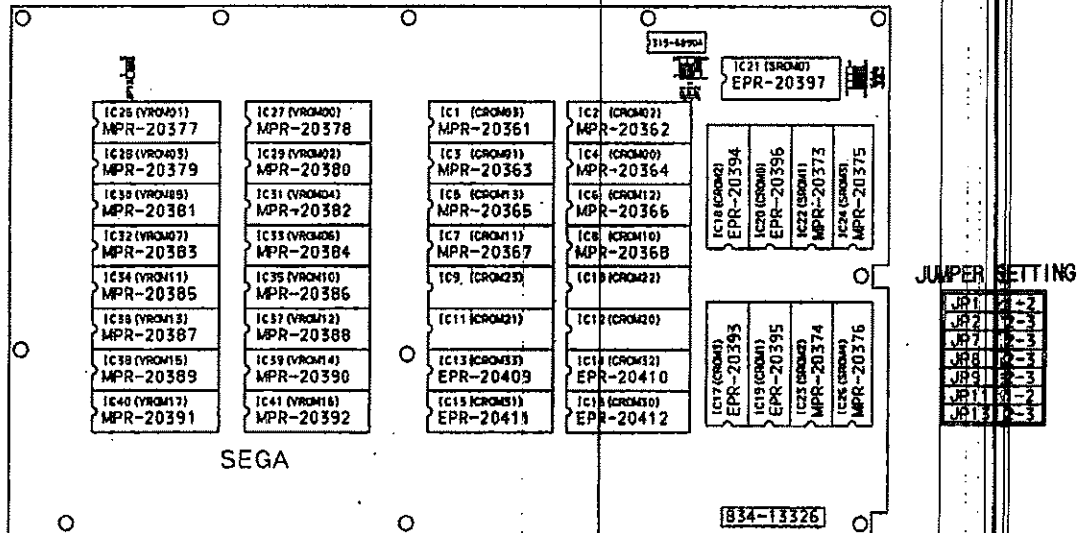

FIG. 17.2

ROM BD HARLEY DAVIDSON (834-13326)



No.	PART No.	DESCRIPTION
①	837-12715	MODEL3 STEP2 CPU BOARD
②	837-12716	MODEL3 STEP2 VIDEO BOARD
③	834-13326	ROM BD HARLEY DAVIDSON
④	837-11861-91	MODEL3 COMM BD COM

18. DESIGN RELATED PARTS

For the Warning Display stickers, refer to Section 1.

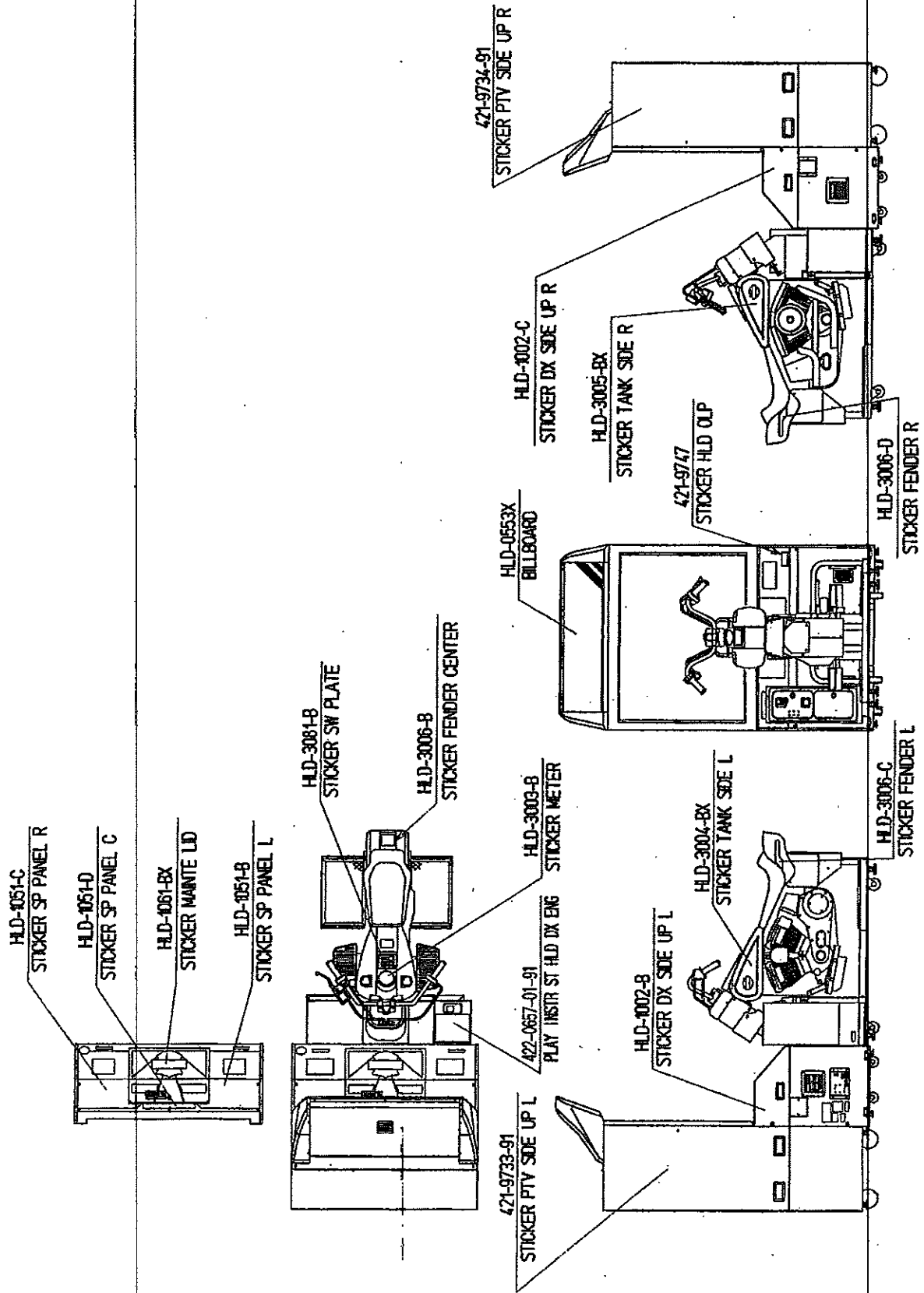

19. COMMUNICATION PLAY



- To avoid electric shock accidents, etc., and to prevent unfair acts, be sure to tightly join the cabinets to be linked.
- Before performing between-cabinets connection work, be sure to turn the power SW off and unplug the power plug from the plug socket. Failure to observe this can cause electric shock or short circuit accidents.

For this game, 4 machines can be connected to allow up to 4 players to play simultaneously.

19-1 INSTALLATION PRECAUTIONS

- 1) When linking a number of machines, be sure to supply sufficient power for the corresponding number of machines. The per unit standard voltage/amperage is 100~120V(area)/10A and 220~240V(area)/7A.
- 2) In order to prevent accidents such as electric shock as well as unfair acts, be sure to tightly join the cabinets.

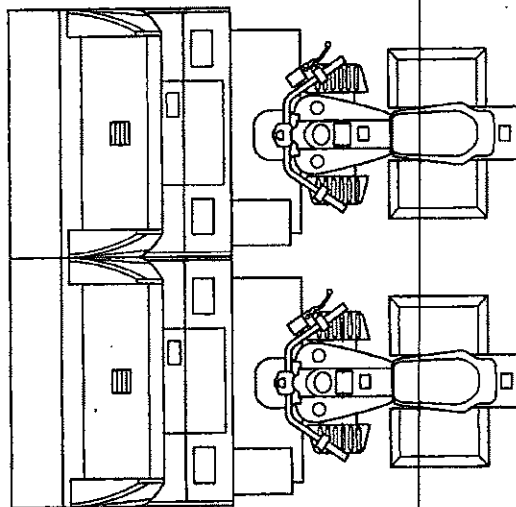

FIG. 19.1

19-2 CONNECTING THE COMMUNICATION CABLES



The Communication Cable is optic-fiber made and will break if excessively bent. Handle with care.

Remove the OPT Connector Lid from the left-hand side of the Front Cabinet, and the 2 connectors which connects the Communication Cable will appear. Depending on the number of machine units to be linked, connect the communication cables (optic fiber cables) in the manner shown in Figures 19. 2 c.

- ① Take out the 2 screws and remove the OPT CONNECTOR LID. (FIG. 19. 2 a)
- ② Take out the 2 screws, unlock, and remove the Maintenance Lid.
- ③ Remove the Cap of the Shield Case's Optic Fiber Cable Connector.
- ④ Lift the Adjusters, have the Casters make contract with the floor, and have the cabinets come close to each other.
- ⑤ Connect the communication cable. (FIG. 19. 2 c)
- ⑥ Tightly join the cabinets together. At this time, use care so as not to damage the communication cables.

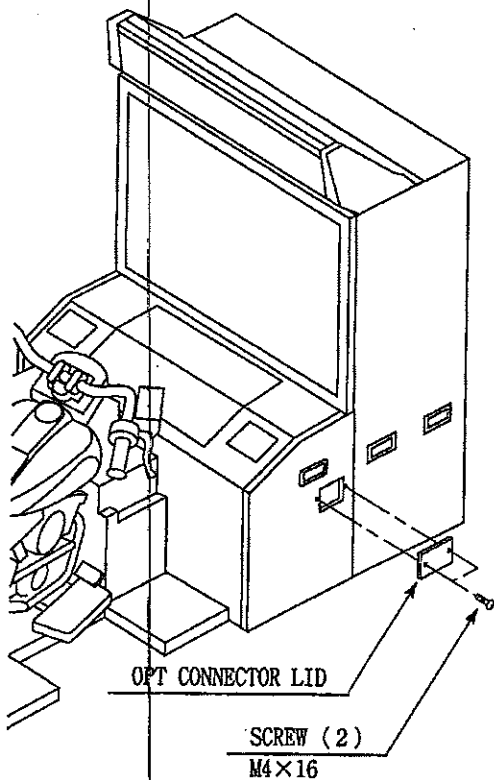

FIG. 19. 2 a

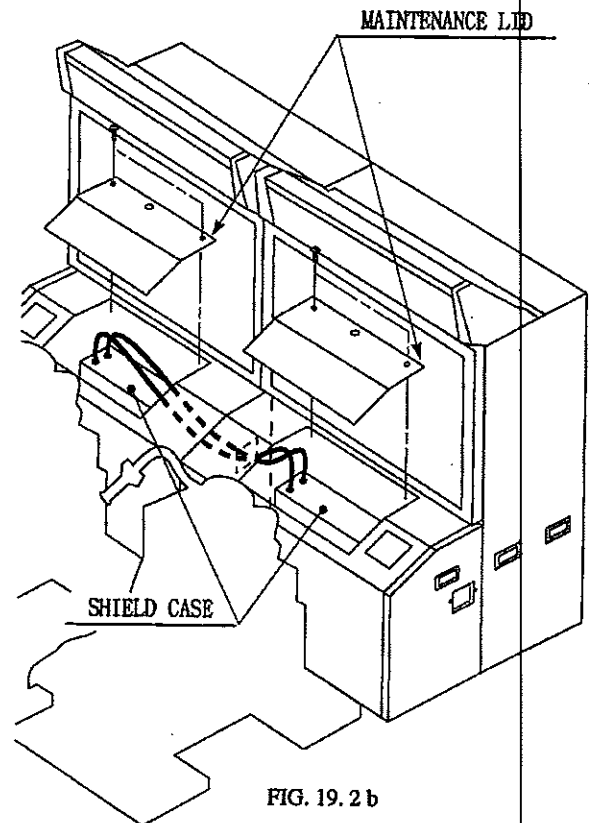

FIG. 19. 2 b

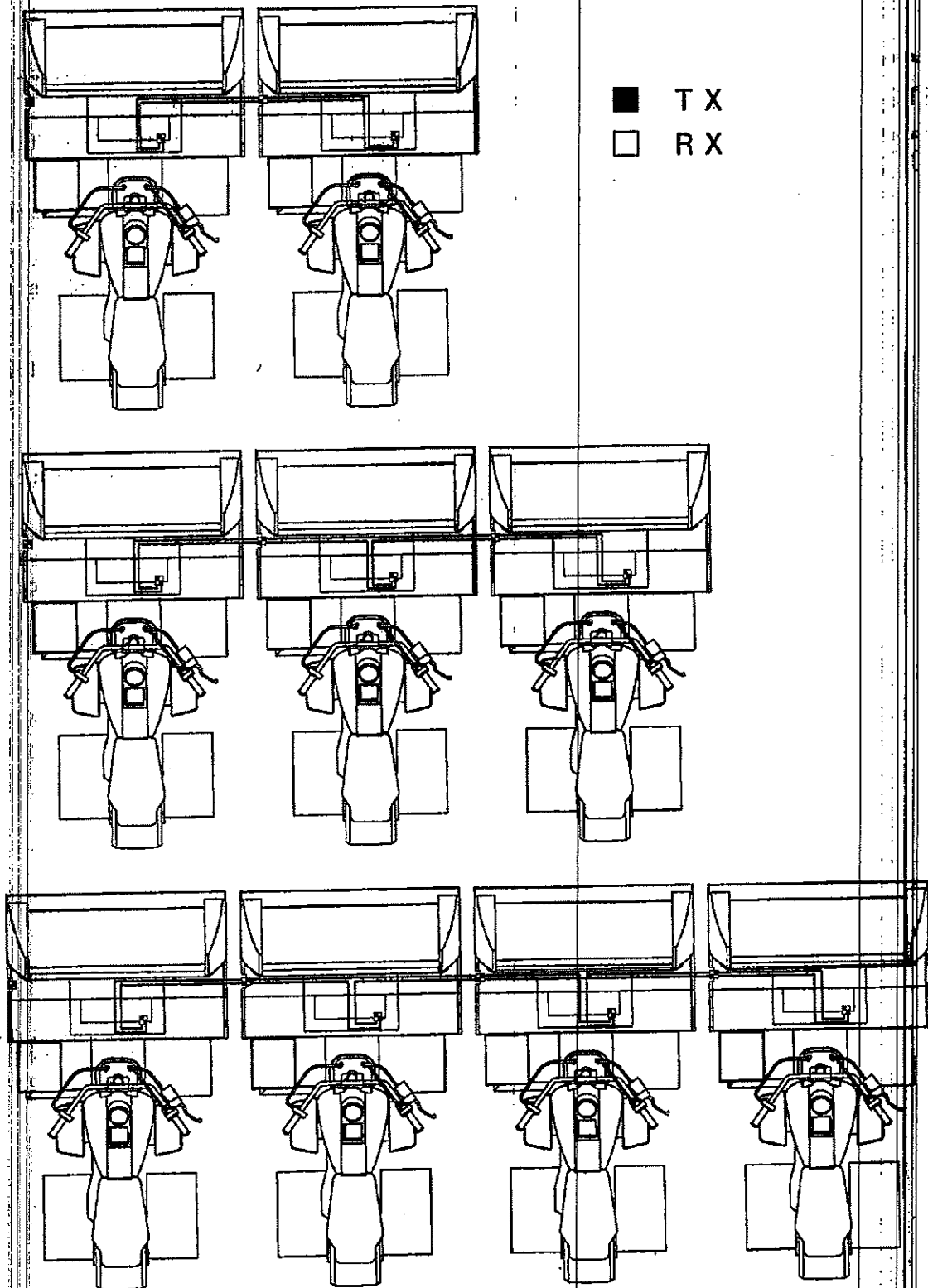

FIG. 19.2 c

- ⑦ Have all of the Adjusters make contact with the floor and ensure that the cabinet is secured to the floor surfaces.
- ⑧ Wire the machine with the power cord & earth wire and protect them by installing covering.
- ⑨ Turn power on to perform setting for communication play. (19 - 3)

19-3 SETTING FOR COMMUNICATION PLAY

STOP
IMPORTANT!

During communication play, if communication is interrupted due to a certain cause, ERROR MESSAGE will be displayed, then the NETWORK check mode appears on the screen automatically.

Cause all of the seats to enter the Test Mode and change the NETWORK ASSIGNMENTS of each seat for communication play. For the changing procedure, refer to the explanations of Section 9.

- ① Press the TEST button to enter the test mode and choose "NETWORK ASSIGNMENTS."
- ② Bring the arrow to COMMUNICATION and select "NETWORK."
- ③ Bring the arrow (→) to PRIVILEGE MODE and press the Test button to set one of the plural seats (basically the leftmost seat) to "MASTER." Set other seats to "SLAVE."
- ④ Bring the arrow mark (→) to "CABINET ID NUMBER," press the TEST button and set the seat number of the machines sequentially to No. 1, No. 2, No. 3 and No. 4 as applicable starting from the extreme left facing the monitor's front side. If the same number is set for 2 or more cabinets, or if the sequential order is incorrect, the game display, etc. will be confused (different from the actual status). Therefore, be careful of this point.

In the case of communication play, all the settings other than CABINET TYPE, B.G.M. VOLUME, and ENGINE VOLUME from among the Game Assignments will be executed by the MASTER SEAT. All other seats ("SLAVE") are subject to the setting change made by the "MASTER" seat.

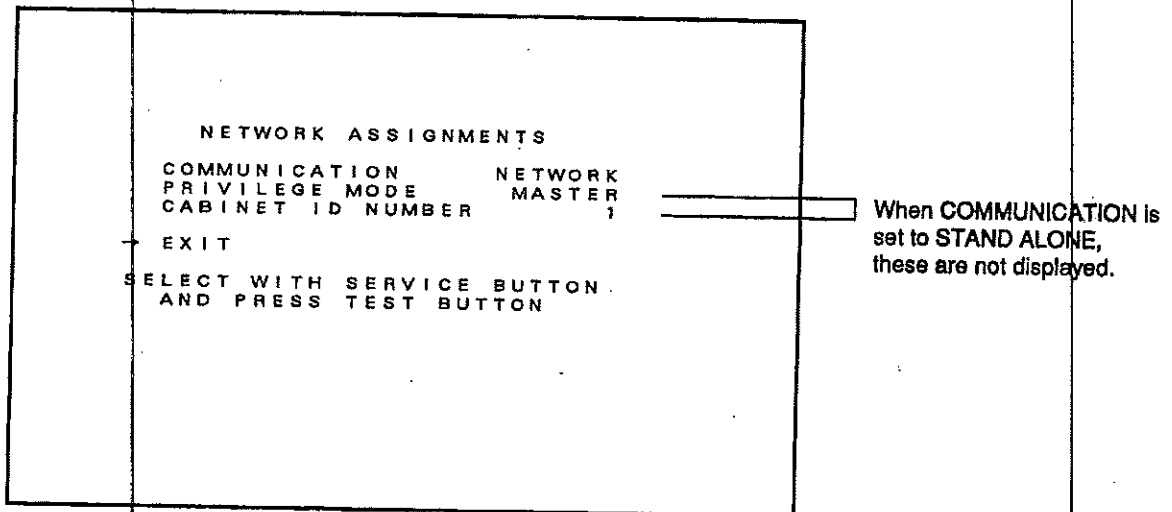

FIG. 19.3 NETWORK ASSIGNMENTS

19-4 NETWORK CHECK

With the communication play setting, NETWORK check is executed when the power is turned on or the test mode is exited.

During the network check, the screen shown right will be displayed. If communication play setting and communication cable connection are correct, the Game mode (the ADVERTISE mode) is displayed and the network check is finished.

```
          CHECKING NETWORK (SLAVE)
NETWORK BOARD      DETECTED
DOWN LOAD         SUCCESS
NETWORK BOARD RAM  GOOD
          PLEASE WAIT
```

Depending on the PRIVILEGE MODE setting, "MASTER" or "SLAVE" is displayed.

FIG. 19.4 a NETWORK CHECK

If communication play setting error or communication cable error is found, the screen shown right appears. Press the test button to enter the test mode. Check and correct the communication play setting.

Check communication cable connection by watching FIG. 19.2 c.

```
          CHECKING NETWORK (MASTER)
NETWORK BOARD      DETECTED
DOWN LOAD         SUCCESS
NETWORK BOARD RAM  GOOD
          OTHER BOARD NOT READY
                   OR
          NETWORK CABLE ERROR
```

FIG. 19.4 b NETWORK ERROR

During communication play, if communication is interrupted due to a certain cause, the screen shown in FIG. 19.4 c appears and then, network check starts automatically.

In the network check, if an irregularity such as the communication cable disconnection is detected, the screen shown in FIG. 19.4 b appears.

```
          NETWORK ERROR
```

FIG. 19.4 c NETWORK ERROR OCCURRED

20. PARTS LIST

① TOP ASSY HARLEY DAVIDSON DX

D-1/2)

SCREW, BOLT FASTENING TORQUE TO BE
 M4 : 18kgf-cm
 M5 : 37kgf-cm
 M8 : 178kgf-cm

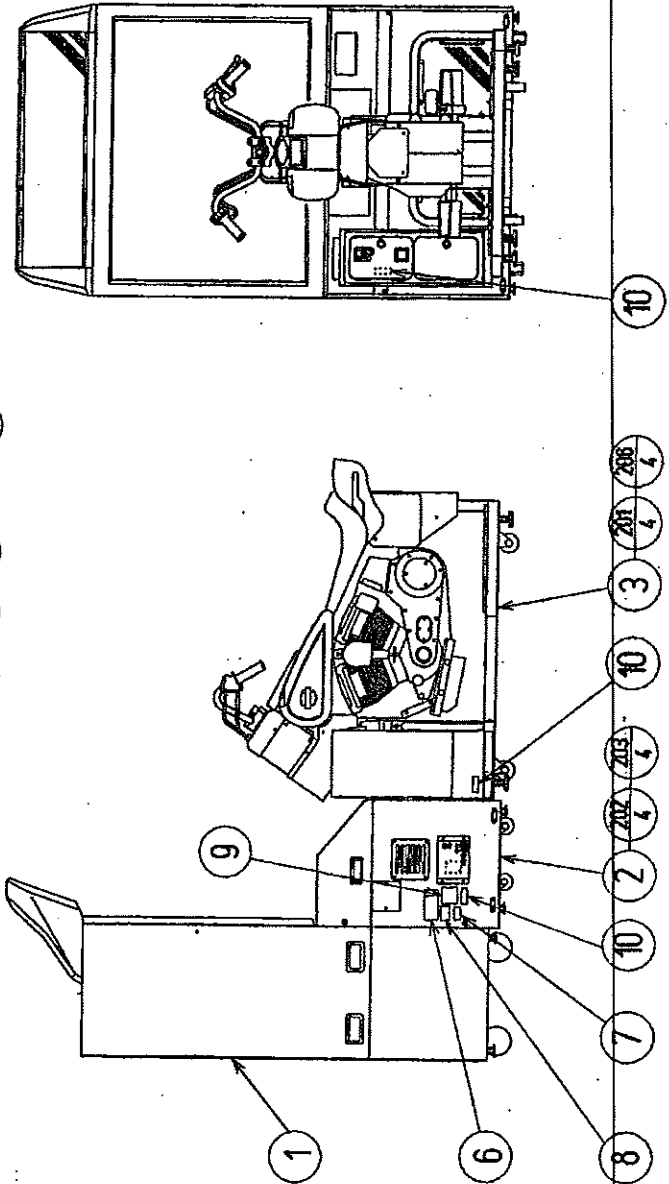
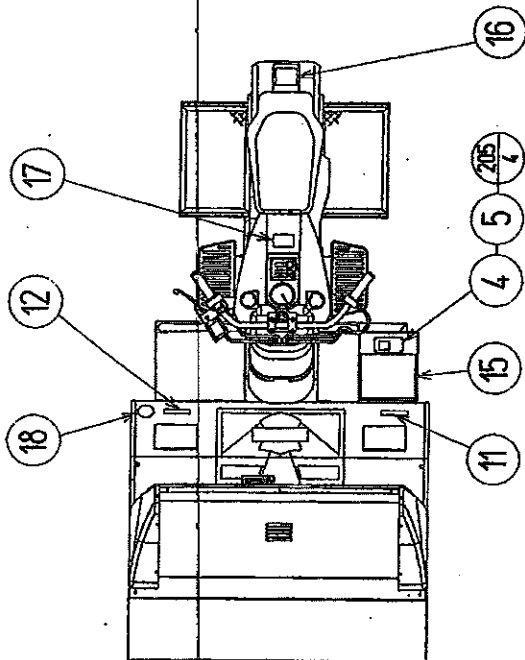

① TOP ASSY HARLEY DAVIDSON DX

(D-2,2)

ITEM NO.	PART NO.	DESCRIPTION	NOTE
1	HLD-0500	ASSY PTV	
2	HLD-1000	ASSY FRONT CABINET	
3	HLD-3000	ASSY REAR CABINET	
4	DYN-0011	DENOMI PLATE W/O ORIGINAL	
5	421-7308- ~	DENOMINATION SHEET 1GAME ~	
6	421-6594-91	STICKER CBRTIFICATB	
7	421-7987	STICKER ELEC SPEC	OTHERS
8	421-8408	STICKER ELBC SPEC TAIWAN	TAIWAN
9	421-7988-91	STICKER SBRIAL NUMBER	
10	SGM-4357	POLY COVER 1600×1300×1050	
11	SGM-4306	POLY COVER 1100×1200×1000	
12	422-0657-01-91	PLAY INSTR ST HLD DX ENG	
13	440-WS0040-BG	STICKER W TTR A BNG	
14	440-WS0042-BG	STICKER W TTR C ENG	
15	421-9747	STICKER HLD OLP	
16			
17			
18			
201	030-000840-SB	HEX BLT W/S BLK M8×40	
202	000-T00525-0C	M SCR TH CRM M5×25	
203	068-552016-0C	FLT WSHR CRM 5.5-20×1.6	
204	008-T00412-0B	TMP PRF SCR TH BLK M4×12	
205	000-T00408-0C	M SCR TH CRM M4×8	
206	068-852216-0B	FLT WSHR BLK 8.5-22×1.6	
207			
208			
209			
210			
401	601-6604-70	CARTON BOX 70	
402	420-6365-01	OWNERS MNL HARLEY DAVIDSON DX ENG	
403	SGM-2675	POLYETHYLENE BAG 240×370	
404	220-5576	KEY MASTER FOR 220-5575	
405	SGM-4111	KEY BAG	
406	220-5484	VOL CONT B-5K QHM	
407	514-5036-7000	FUSE 6.4×30 7000MA 125V	
408	600-6724	AC CABLE CONNBCT TYPE 15A	} TAIWAN
409	600-6729	AC CABLE CONNBCT TYPE 15A	
410	600-6618	AC CABLE CONNBCT TYPE FOR EXP	} OTHERS
411	600-6695	AC CABLE CONNBCT TYPE USA 15A	
	600-6695-01	AC CABLE CONNBCT TYPE USA 15A	} USA
	600-6275-0200	ASSY FIBER CABLE 5 0200CM	
412			
	GPD-0002X	SHIPPING BRKT	
	030-000825-S	HEX BLT W/S M8×25	
	060-F00800	FLT WSHR M8	
	421-8740	CAUTION INSTR COP U/R	
	421-6690-06	STICKER 110V	AC 110V AREA
	421-6690-03	STICKER 220V	AC 220V AREA
	421-6690-05	STICKER 240V	AC 240V AREA
	421-6690-01	STICKER 120V	AC 120V AREA
	421-6119-91	STICKER FCC	} USA
	421-6120-91	STICKER SEGA USA	

② ASSY PTV (HLD-0500)

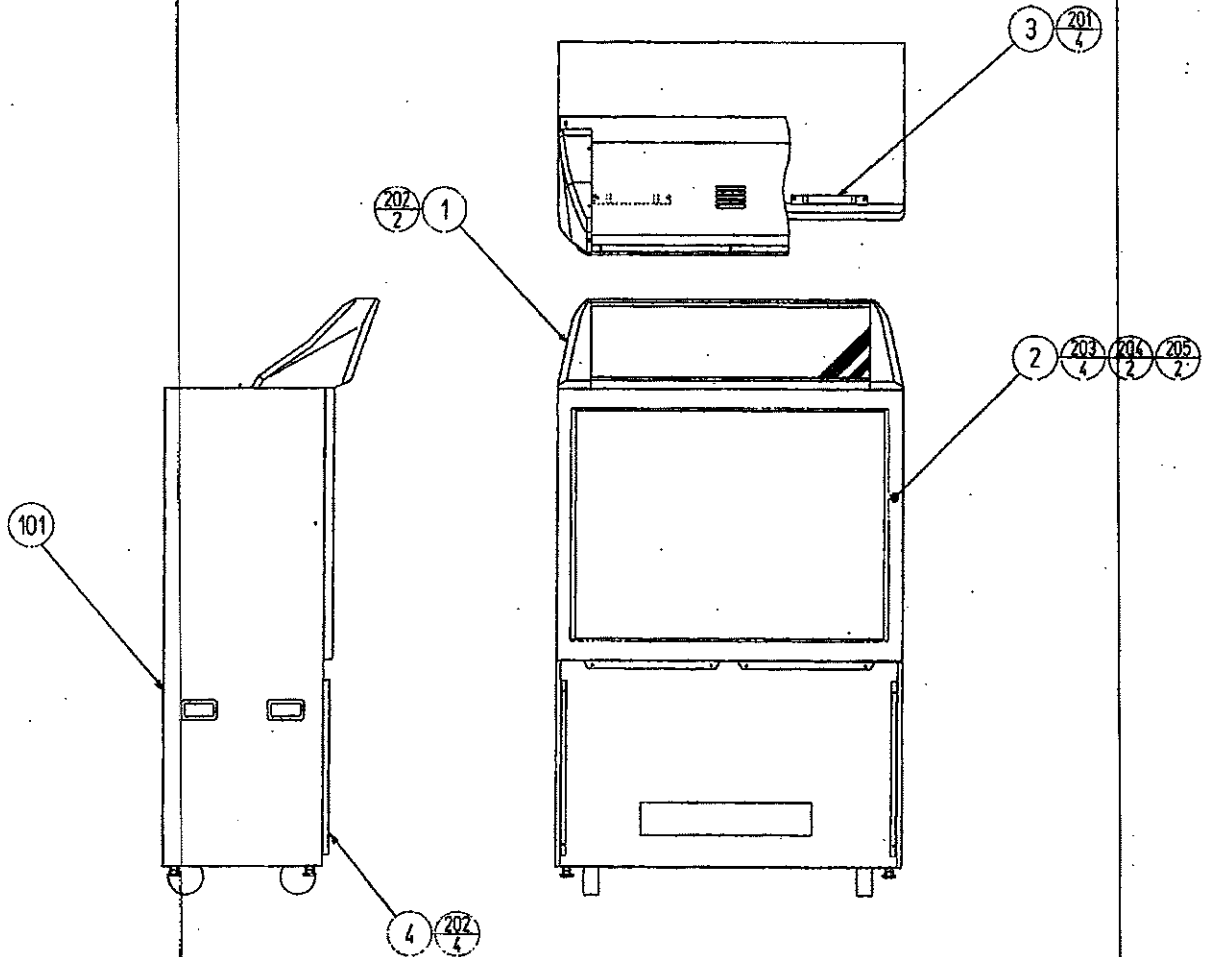

ITBM NO.	PART NO.	DESCRIPTION	NOTE
1	HLD-0550	ASSY BILLBOARD	
2	MGL-1150	ASSY MASK	
3	RAL-0501	MASK HOLDER	
4	HLD-0501	SIDE BRKT	
101	200-5315-01-HLD 200-5639-HLD	ASSY PROJECTION DISPLAY HLD ASSY PROJECTION DISPLAY US HLD	OTHERS USA
201	000-F00414	M SCR PH M4×14	
202	000-P00516-W	M SCR PH W/FS M5×16	
203	000-T00520-0B	M SCR TH BLK M5×20	
204	000-T00525-0C	M SCR TH CRM M5×25	
205	068-552016-0C	FLT WSHR CRM 5.5-20×1.6	

③ ASSY BILLBOARD (HLD-0550)

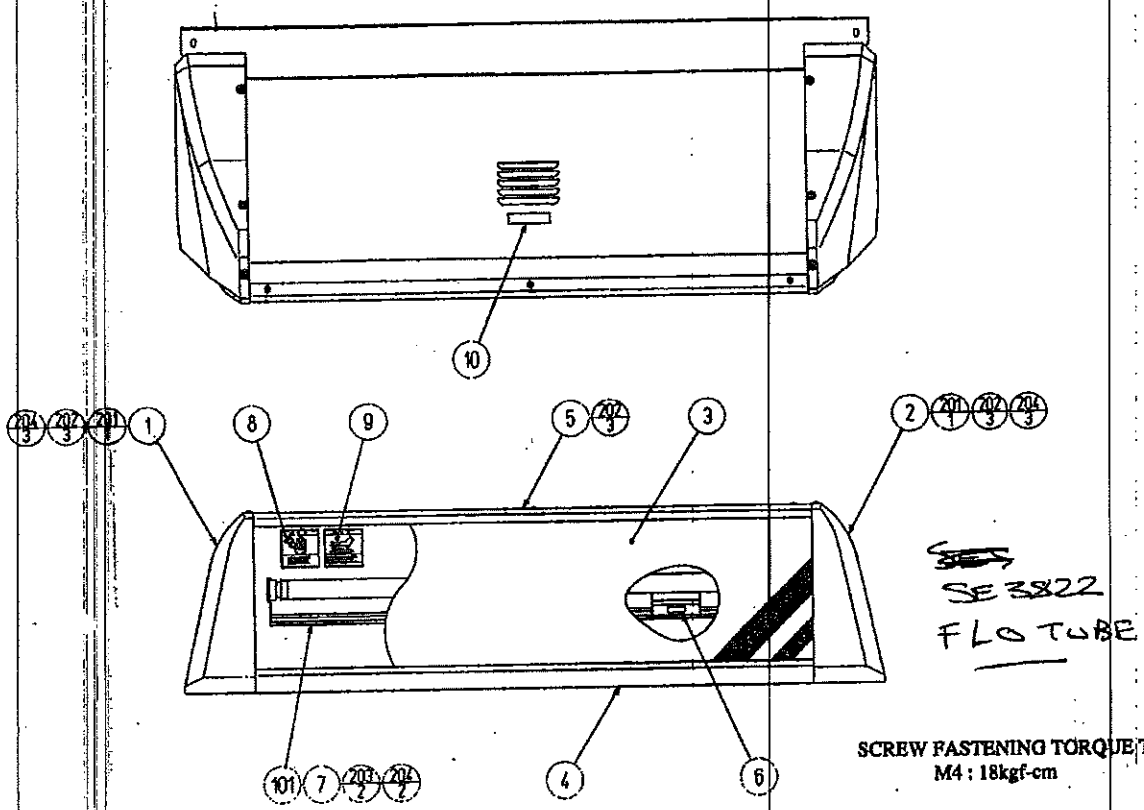

ITEM NO.	PART NO.	DESCRIPTION	NOTE
1	HLD-0551	LBFT COVER	
2	HLD-0552	RIGHT COVER	
3	HLD-0553X	BILLBOARD	
4	HLD-0554	BILLBOARD BOX	
5	HLD-0555	BILLBOARD HOLDER	
6	421-7501-18	STICKBR FL32W	
7	253-5457	FL HOLDER	
8	440-WS0002XBG	STICKBR W POWER OFF ENG	
9	440-WS0012XBG	STICKBR W HIGH TEMP ENG	
101	390-5695-32EX	ASSY FL32W BX W/CONN HIGH T CB.)	
102	280-5009	CORD CLAMP 21	
201	000-F00410	M SCR FH M4×10	
202	000-T00408-0C	M SCR TH CRM M4×8	
203	000-P00430-S	M SCR PH W/S M4×30	
204	068-441616-0C	FLT WSHR CRM 4.4-16×1.6	
205	000-P00408-W	M SCR PH W/FS M4×8	
301	600-6790-108	WIRE HARN EXT FL IBC	

④ ASSY MASK (MGL-1150)

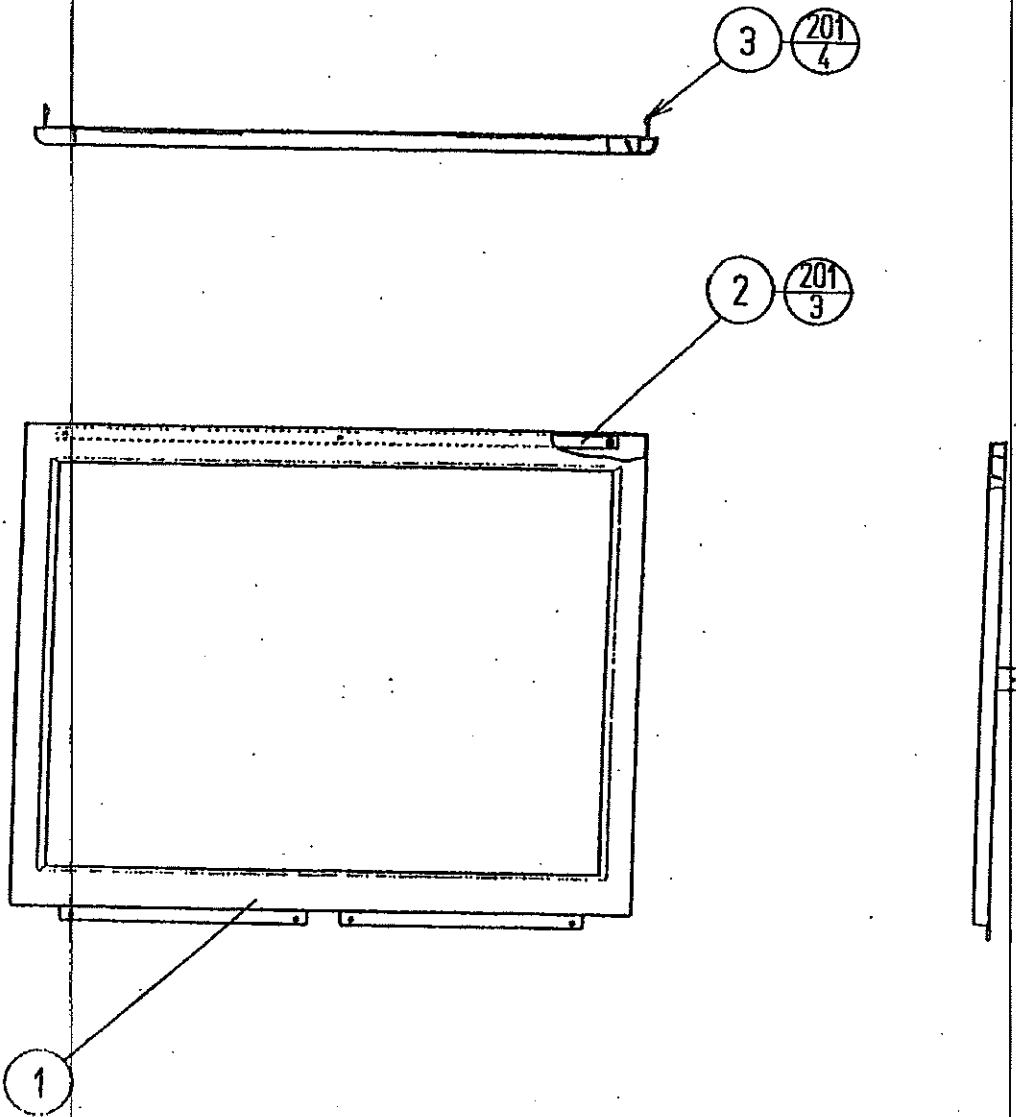

ITEM NO.	PART NO.	DESCRIPTION	NOTE
1	MGL-1102	TV MASK	
2	MGL-1151	SLIT PLATE	
3	MGL-1152	MASK SIDE HOLDER	
201	012-F00408-0B	TAP SCR PH BLK 4×8	
202	000-F00410	M SCR PH M4×10	

⑤ ASSY FRONT CABINET (HLD-1000)

① ②

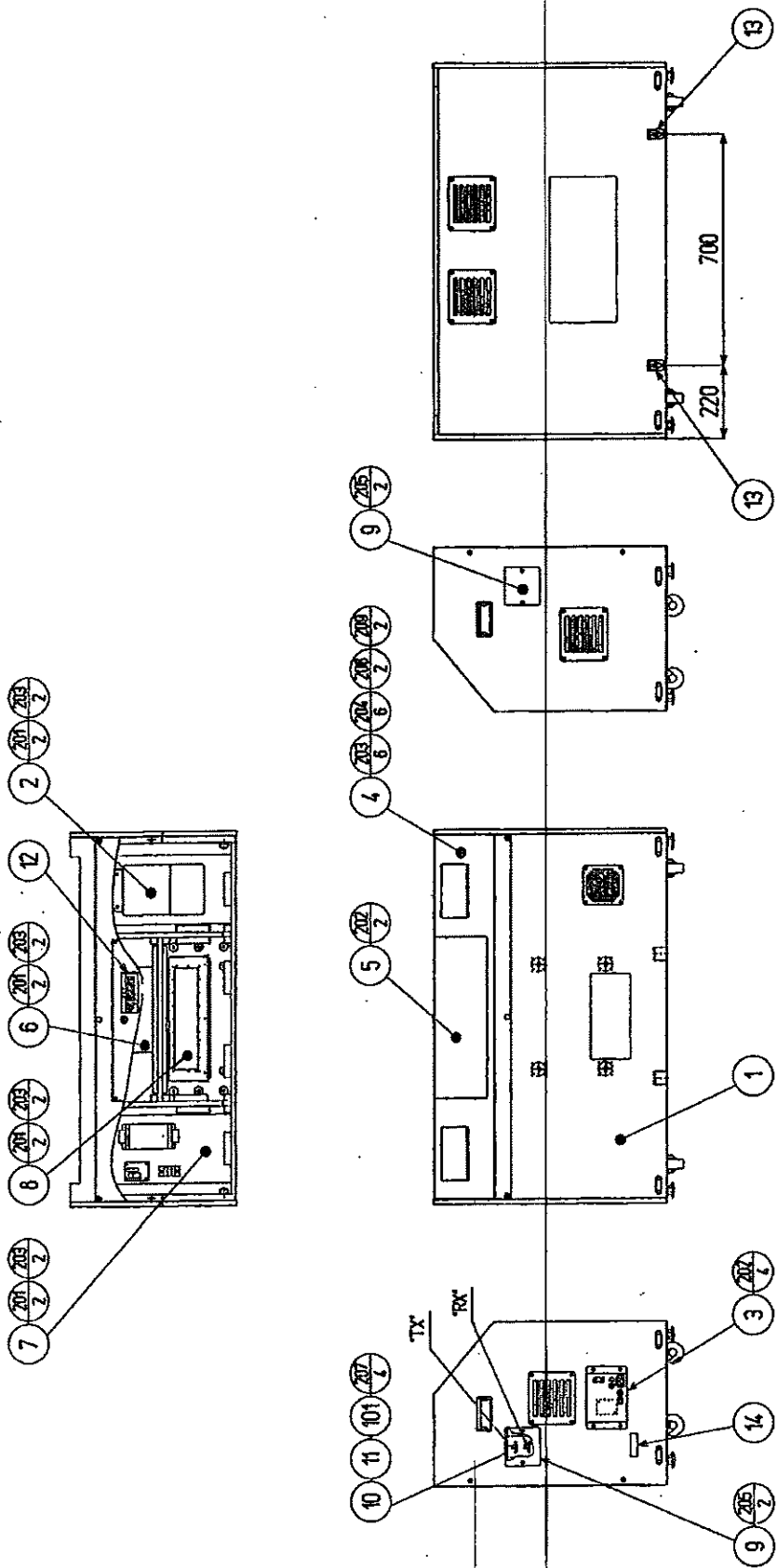

⑤ ASSY FRONT CABINET (HLD-1000)

(D-2/2)

ITEM NO.	PART NO.	DESCRIPTION	NOTE
1	HLD-1001	ASSY SUB-CABI DX	
2	HLD-1030	ASSY WOOPER	
3	HLD-1040	AC UNIT	
4	HLD-1050	ASSY MAIN LID	
5	HLD-1060	ASSY MAINTENANCE LID	
6	HLD-4000	ASSY PWR SPLY	
7	HLD-4200	ASSY XFMR	
8	HLD-4300	ASSY MAIN BD	
9	HLD-1003	OPT CONN LID	
10	TTR-1012	OPT CONN BRKT	
11	421-7515	STICKER FIBER CABLE TX/RX	
12	440-WS0033XEG	STICKER W BD POWER OFF BNG	
13	421-8885	STICKER CAUTION FORK	
101	211-5479-01	CONN OPT JOINT	
201	000-P00435-W	M SCR PH W/FS M4×35	
202	000-T00416-OB	M SCR TH BLK M4×16	
203	068-441616-OB	FLT WSHR BLK 4, 4-16×1.6	
204	000-T00425-OB	M SCR TH BLK M4×25	
205	000-T00416-OC	M SCR TH CRM M4×16	
207	000-P00312-W	M SCR PH W/FS M3×12	
208	031-000425-OB	CRG BLT BLK M4×25	
209	050-F00400	FLG NUT M4	

6) ASSY SUB-CABI DX (HLD-1001)

(D-12)

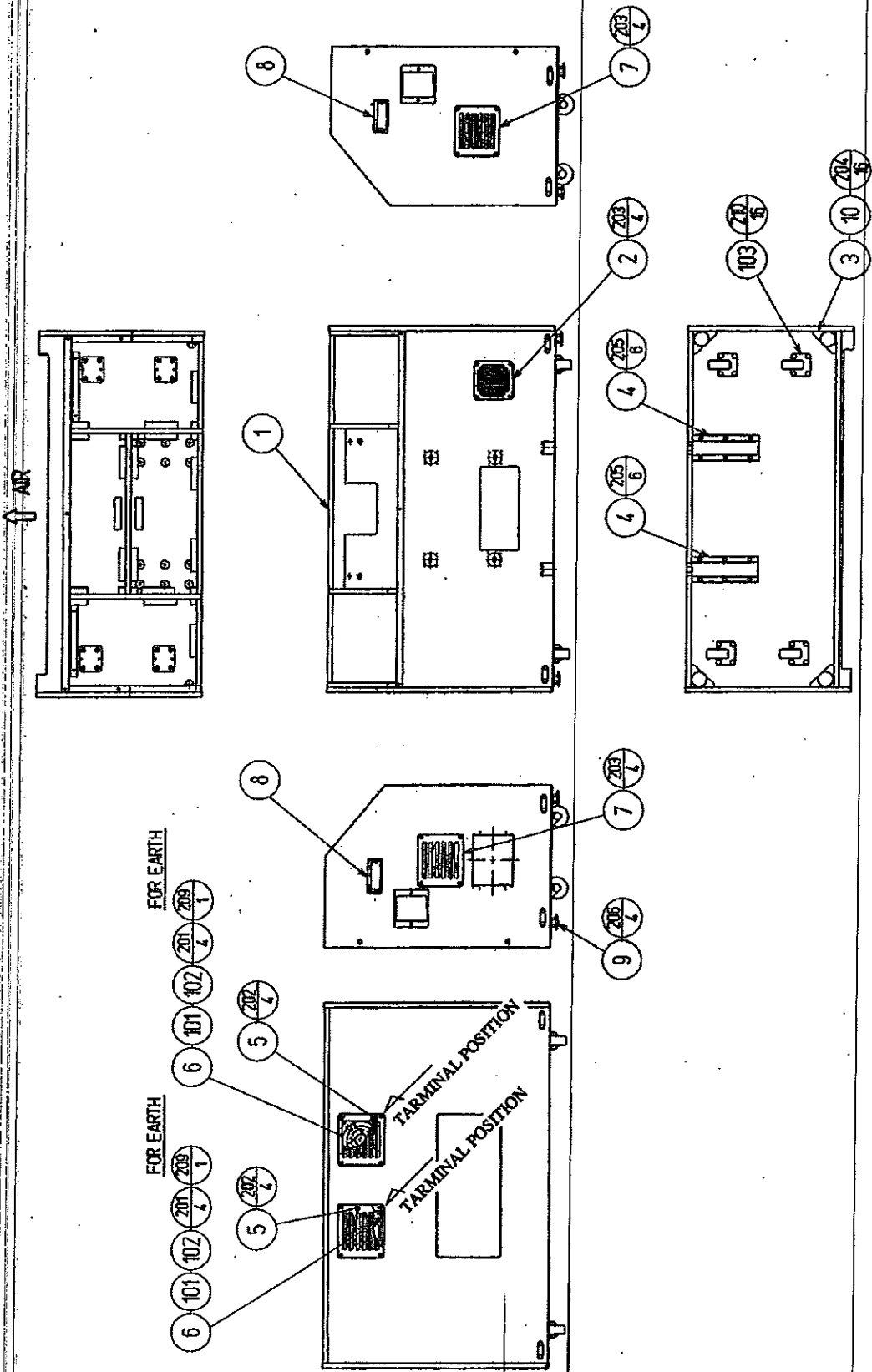

⑥ ASSY SUB-CABI DX (HLD-1001)

(D-2/2)

ITEM NO.	PART NO.	DESCRIPTION
1	HLD-1002	FRONT CABINET
2	HLD-1004	WOOFER NET
3	TTR-1010	LEG BRKT
4	TTR-1015	CATCH BRKT
5	UP-1018	AIR VENT
6	105-5275	FAN BRKT
7	105-5239-03	AIR VENT
8	253-5396-91	CABINET HANDLE
9	601-5699X	LEG ADJUSTER BOLT M16×75
10	117-5216	PLATE LEG BRACKET
101	260-0011-02	AXIAL FLOW FAN AC100V 50-60Hz
102	601-8543	FAN GUARD
103	601-5471	CASTER
104	280-0419	HARNES LUG
105	280-5009	CORD CLAMP 21
106	601-0460	PLASTIC TIE BBLT 100MM
201	000-P00316-W	M SCR PH W/FS M3×16
202	000-T00416-0B	M SCR TH BLK M4×16
203	000-T00416-0C	M SCR TH CRM M4×16
204	030-000630-SC	HEX BLT W/S CRM M6×30
205	030-000616-S	HEX BLT W/S M6×16
206	050-H01600	HEX NUT M16
207	011-F00310	TAP SCR FH 3×10
208	011-T03512	TAP SCR TH 3.5×12
209	000-P00406-W	M SCR PH W/FS M4×6
210	030-000825-S	HEX BLT W/S M8×25
301	600-6984-006	WIRE HARN FRONT CABI EXT1
302	600-6984-017	WIRE HARN FRONT CABI EXT2
303	600-6984-018	WIRE HARN FRONT CABI EXT3
304	600-6984-019	WIRE HARN FRONT CABI EXT4
305	600-6921-20	ASSY RGB CABLE D-BNC 200CM
306	600-6984-035	WIRE HARN E FRONT CABI1
307	600-6984-036	WIRE HARN E FRONT CABI2
308	600-6984-037	WIRE HARN E FRONT CABI3

⑦ ASSY WOOFER (HLD-1030)

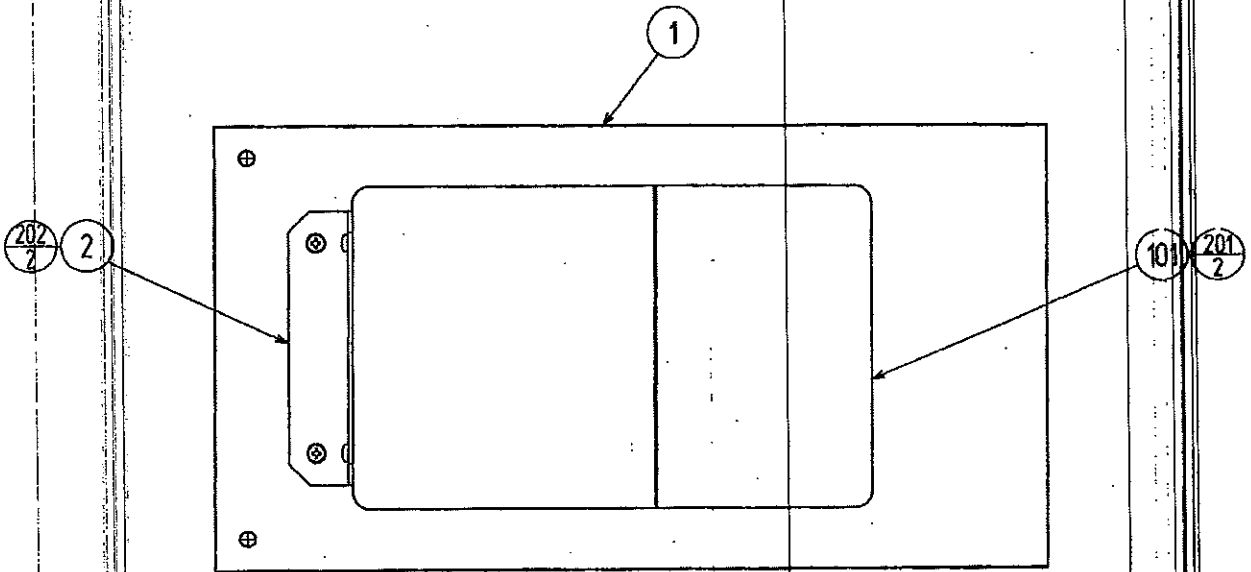

ITEM NO.	PART NO.	DESCRIPTION	NOTE
1	HLD-1031	WOOFER BASE	
2	HLD-1032	WOOFER BRKT	
101	130-5155	SPBAKER BOX SUB WOOFER	
201	012-P00412	TAP SCR #2 PH 4×12	
202	000-P00414-W	M SCR PH W/FS M4×14	

⑧ AC UNIT (HLD-1040)

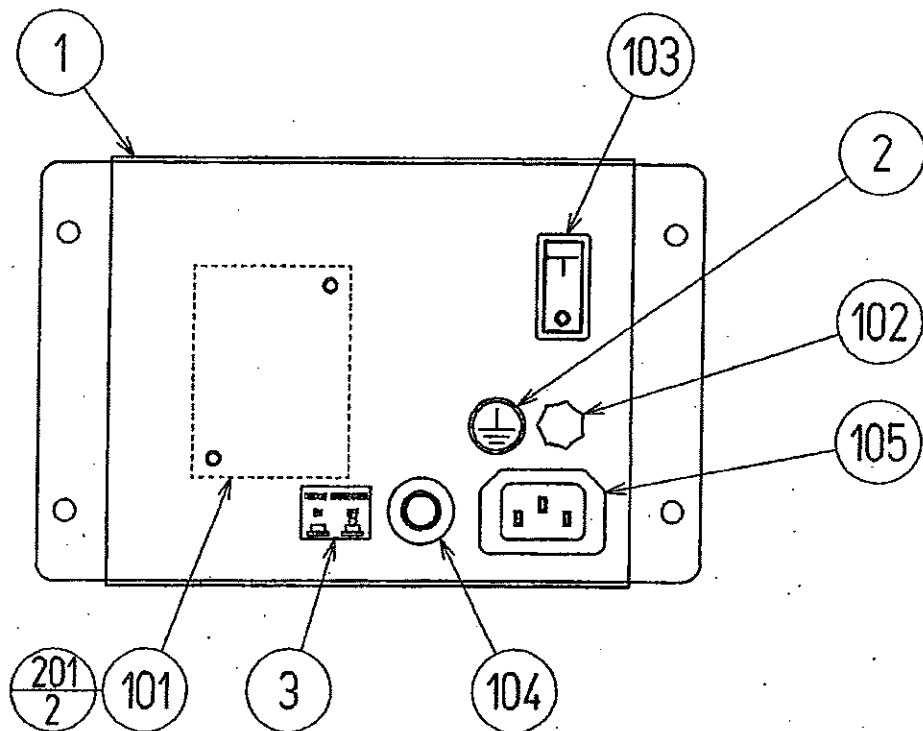

ITEM NO.	PART NO.	DESCRIPTION	NOTE
1	TTR-1261	AC BRKT EXP	
2	421-8202	STICKER EARTH MARK	
3	421-7468-01	STICKER C. P W/PIC	
101	450-5126	MAGNET CONTACT S-NIOCX	TAIWAN
	450-5134	MAGNET CONTACT S-NIOCX AC 230V	OTHERS
	450-5133	MAGNET CONTACT S-NIOCX AC 200V	KOREA
	450-5135	MAGNET CONTACT S-NIOCX AC 120V	USA
102	280-0417	TERMINAL BINDING POST BLACK	
103	509-5453-V-B	SW ROCKBR J8 V-B	
104	512-5046-10000	C. P 10000MA CB UL	TAIWAN
	512-5046-5000	C. P 5000MA CB UL	OTHERS
105	214-0202	AC INLET PANEL TYPE	
106	280-5009-01	CORD CLAMP 21	
107	601-0460	PLASTIC TIE BELT 100MM	
108	310-5029-J20	SUMI TUBE F J 20MM	
109	310-5029-G20	SUMI TUBE F G 20MM	
201	000-P00416-W	M SCR PH W/FS M4×16	
301	600-6984-005	WIRE HARN AC UNIT	

9) ASSY MAIN LID (HLD-1050)

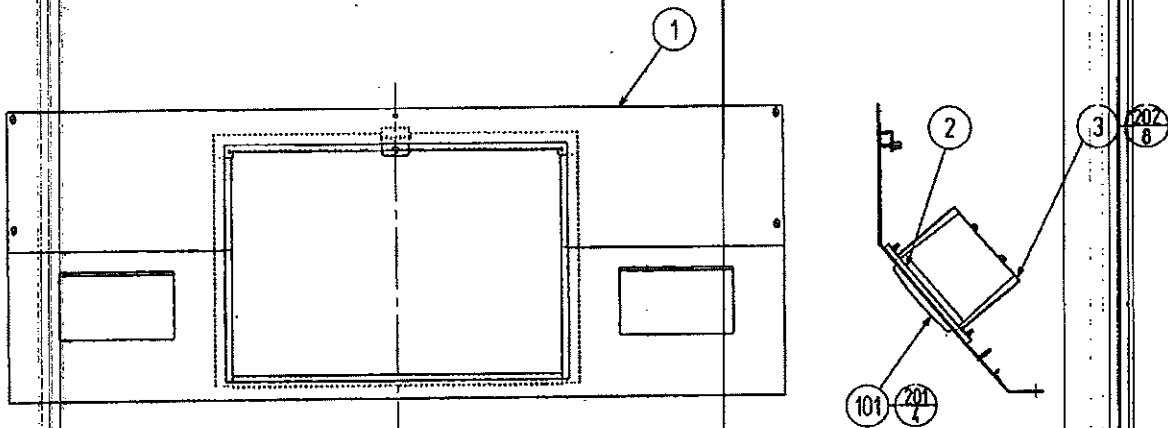

ITEM NO.	PART NO.	DESCRIPTION	NOTE
1	HLD-1051	SPEAKER PANEL	
2	HLD-1052	SPEAKER BASB	
3	HLD-1053	SPEAKER BRKT	
101	130-5096	ASSY SRVO SPEAKER BOX	
102	280-5008	CORD CLAMP 15	
103	280-5275-SR10	CORD CLAMP SR10	
201	000-P00512-W	M SCR FH W/FS M5×12	
202	050-F00400	FLG NUT M4	
203	060-S00400	SPR WSHR M4	
204	060-F00400	FLT WSHR M4	
205	050-H00400	HBX NUT M4	
301	600-6984-020	WIRE HARN FRONT SPEAKER	

⑩ ASSY MAINTENANCE LID (HLD-1060)

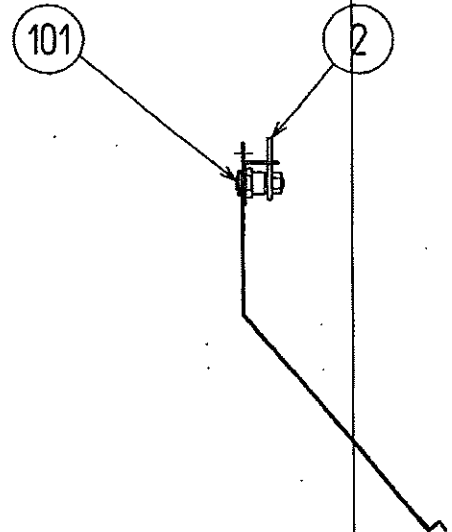
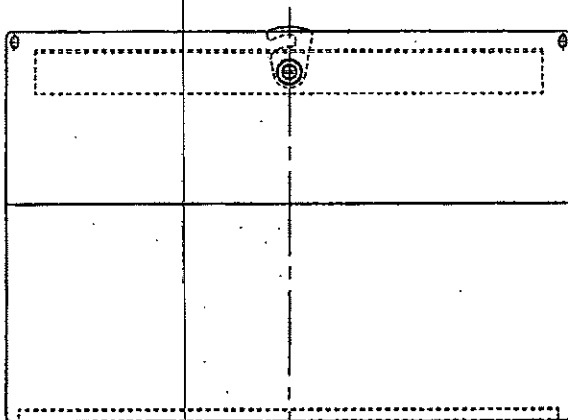

ITEM NO.	PART NO.	DESCRIPTION	NOTE
1	HLD-1061	MAINTENANCE LID	
2	TH-1015	LOCKING TONGUE	
101	220-5575	CAM LOCK MASTBR W/O KBY	

11 ASSY PWR SPLY (HLD-4000)

(2)

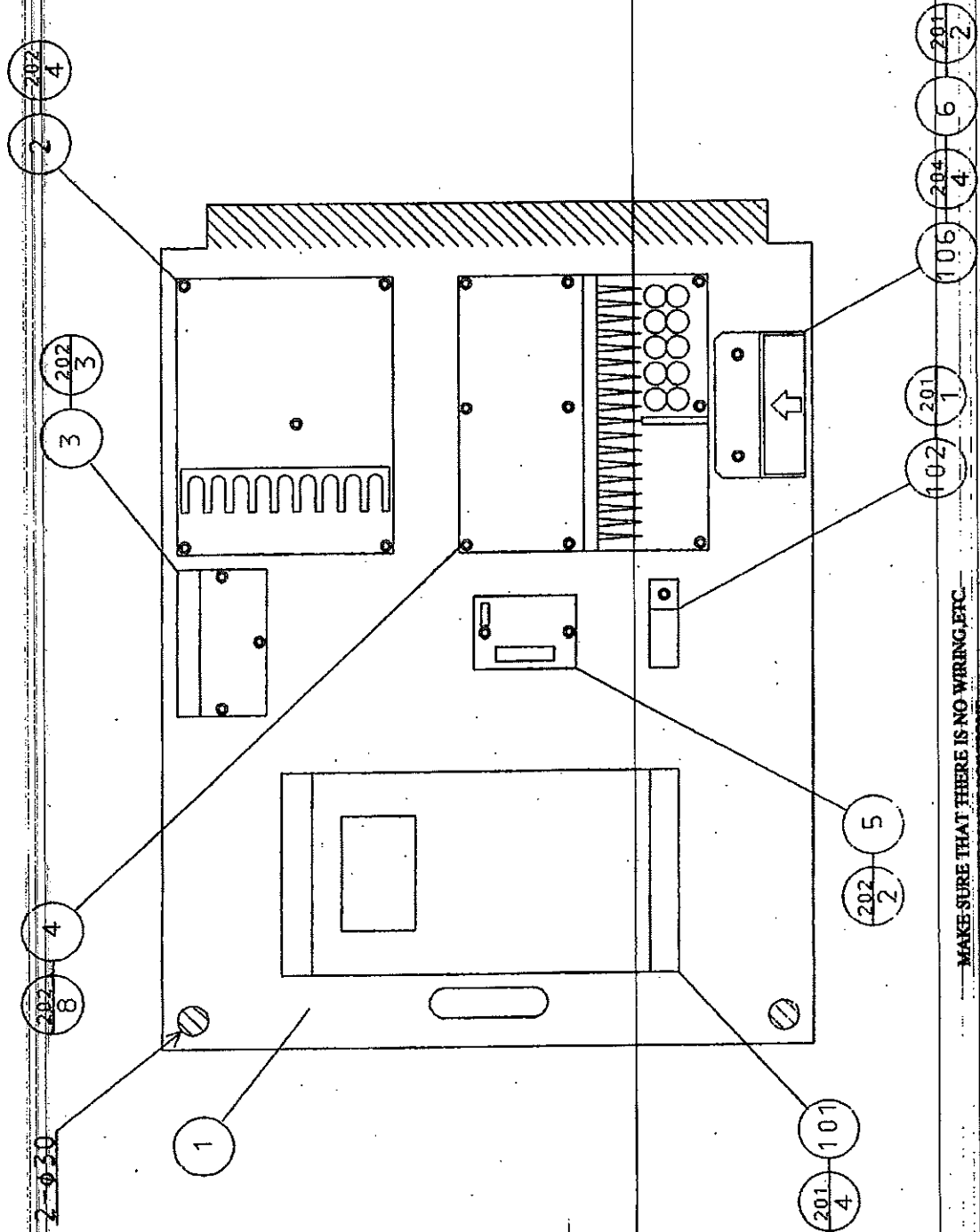

2-030

MAKE SURE THAT THERE IS NO WIRING, ETC. IN THE SLASH MARK POSITIONS

⑪ ASSY PWR SPLY (HLD-4000)

(D-2/2)

ITEM NO.	PART NO.	DESCRIPTION	NOTE
1	HLD-4001	WOODEN BASE BLEC	
2	838-11650-35	EQ. PWR AMP HLD DX	
3	838-11651-91	LOWPASS AMP	
4	838-13142	BASS AMP 50W×2	
5	839-0233-06CE	SSR 3A BD CE	
6	DYN-2405	FAN BRKT	
101	400-5330-02-91	SW REGU FOR MODEL3	
102	400-5354	RECTIFIER DC45V	
103	280-5009	CORD CLAMP 21	
104	280-0419	HARNESS LUG	
105	601-0460	PLASTIC TIE BBLT 100MM	
106	260-0073	FAN MOTOR DC12V	
107	209-0023	CONN CLOSBD END	
108	280-5275-SR10	CORD CLAMP SR10	
201	011-T03512	TAP SCR TH 3.5×12	
202	011-P00325	TAP SCR PH 3×25	
203	011-F00310	TAP SCR PH 3×10	
204	000-P00330-W	M SCR PH W/FS M3×30	
301	600-6984-007	WIRE HARN PWR SPLY1	
302	600-6984-008	WIRE HARN PWR SPLY2	
303	600-6984-009-91	WIRE HARN PWR SPLY3	
304	600-6984-010	WIRE HARN PWR SPLY4	
305	600-6984-011	WIRE HARN PWR SPLY5	
306	600-6984-012	WIRE HARN PWR SPLY6	
307	600-6984-013	WIRE HARN PWR SPLY7	

⑫ ASSY XFMR (HLD-4200)

(D-2/2)

2-Ø30

⑩① ②①
4

①

PRIMALY

SECONDALY

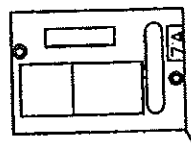
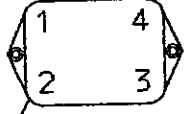

②③
2 ①②

② ②②
2 ③ ①⑥

MAKE SURE THAT THERE IS NO WIRING, ETC.
IN THE SLASE MARK PORTIONS.

⑫ ASSY XFMR (HLD-4200)

(D-2/2)

ITEM NO.	PART NO.	DESCRIPTION	NOTE
1	HLD-4201	WOODEN BASE XFMR	
2	838-11856-01	CONNECT BD W/FUSE & COVER	
	838-11856-01-UL	CONNECT BD W/FUSE & COVER UL	
3	421-6595-11	STICKER 7A	
101	560-5380	AUDIO XFMR 12.8V6A 23V9.6AX2	
102	270-5081	NOISE FILTER 20A	
103	280-5009	CORD CLAMP 21	
104	280-0419	HARNESS LUG	
105	601-0460	PLASTIC TIE BELT 100MM	
106	514-5036-7000	FUSE 6.4×30 7000MA 125V	
201	000-P00616-W	M SCR PH W/FS M6×16	
202	011-P00325	TAP SCR PH 3×25	
203	011-T03512	TAP SCR TH 3.5×12	
204	011-F00310	TAP SCR FH 3×10	
301	600-6984-001	WIRE HARN XFMR1	
302	600-6984-002	WIRE HARN XFMR2	
303	600-6984-003	WIRE HARN XFMR3	
304	600-6984-004	WIRE HARN XFMR4	
/	600-6984-040	WIRE HARN STEP DOWN IN	
/	600-6984-041	WIRE HARN STEP DOWN OUT	
/	560-5384	XFMR 100-120V 100V 10A WB	AC 110~120V AREA
/	560-5377	PWR XFMR 200-240V 100V 10A CB	AC 220~240V AREA

⑬ ASSY MAIN BD (HLD-4300)

2-φ30

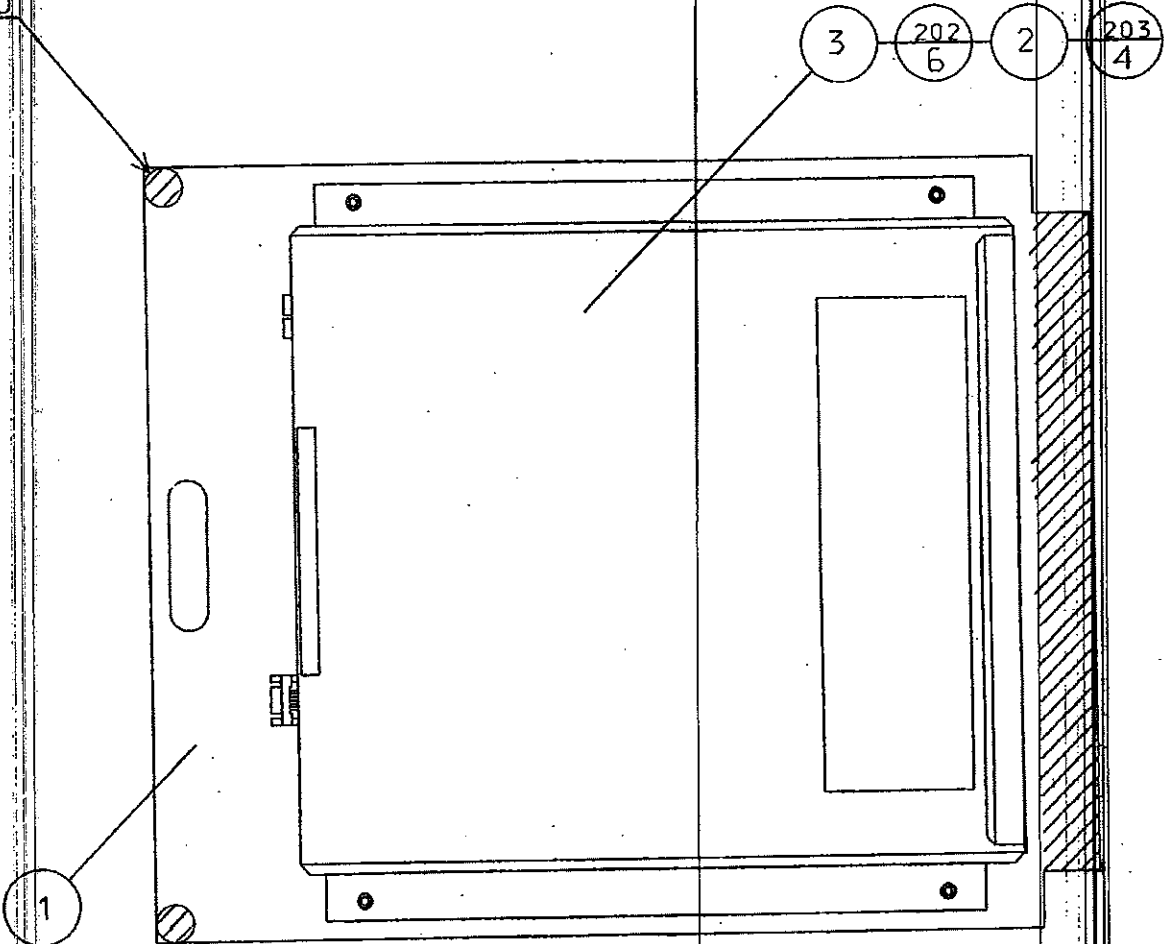

MAKE SURE THAT THERE IS NO WIRING, ETC.
IN THE SLASE MARK PORTIONS.

ITEM NO.	PART NO.	DESCRIPTION	NOTE
1	HLD-4301	WOODEN BASE GAME BD	
2	HLD-4400	ASSY SHIELD CASE	
3	105-5241	SHIELD CASE BRKT	
101	280-5009	CORD CLAMP 21	
102	601-0460	PLASTIC TIE BELT 100MM	
201	011-F00310	TAP SCR FH 3×10	
202	000-P00408-W	M SCR PH W/FS M4×8	
203	000-P00412-W	M SCR PH W/FS M4×12	
301	600-6984-014	WIRE HARN MAIN BD1	
302	600-6984-015	WIRE HARN MAIN BD2	
303	600-6984-016	WIRE HARN MAIN BD3	

⑭ ASSY SHIELD CASE (HLD-4400)

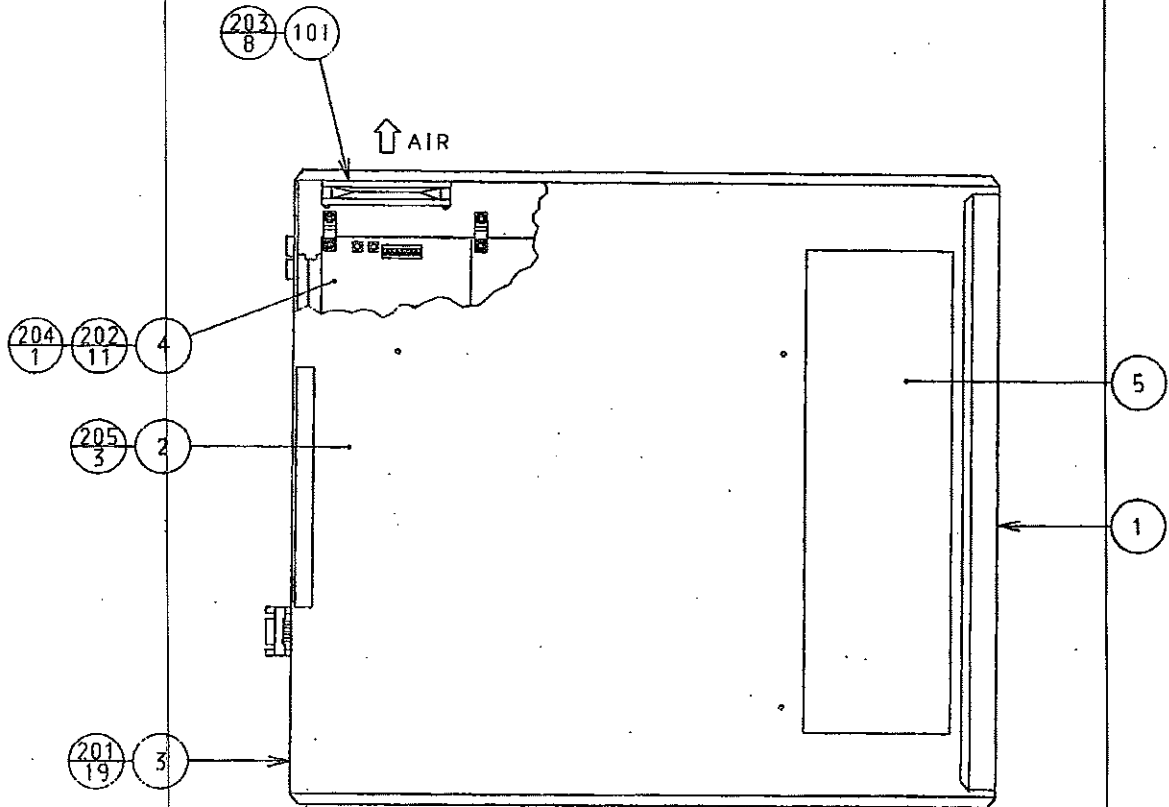

ITEM NO.	PART NO.	DESCRIPTION	NOTE
1	105-5240Y	SHIELD CASE MODEL3	
2	105-5242X	SHIELD CASE LID MODEL3	
3	839-0932	FILTER BD MODEL3 SPG	
4	833-13325	GAME BD HARLEY DAVIDSON	
5	421-9174-01	STICKER CAUTION ANTISTATIC	
6	421-6510-13325	STICKER 833-13325	
7	601-8928	CARTON BOX MODEL3	
101	260-0064	FAN MOTOR DC12V	
102	280-2575-SR10	CORD CLAMP SR10	
103	601-0460	PLASTIC TIE BELT 100MM	
201	010-P00308-F	S-TITE SCR PH W/F M3×8	
202	010-P00310-F	S-TITE SCR PH W/F M3×10	
203	000-P00320-W	M SCR PH W/FS M3×20	
204	010-P00365-F	S-TITE SCR PH W/F M3×65	
205	000-P00408-W	M SCR PH W/FS M4×8	
301	600-6739-54	WIRE HARN FAN MOTOR	

15 MASSY REAR CABINET (HLD-3000)

(D) 3

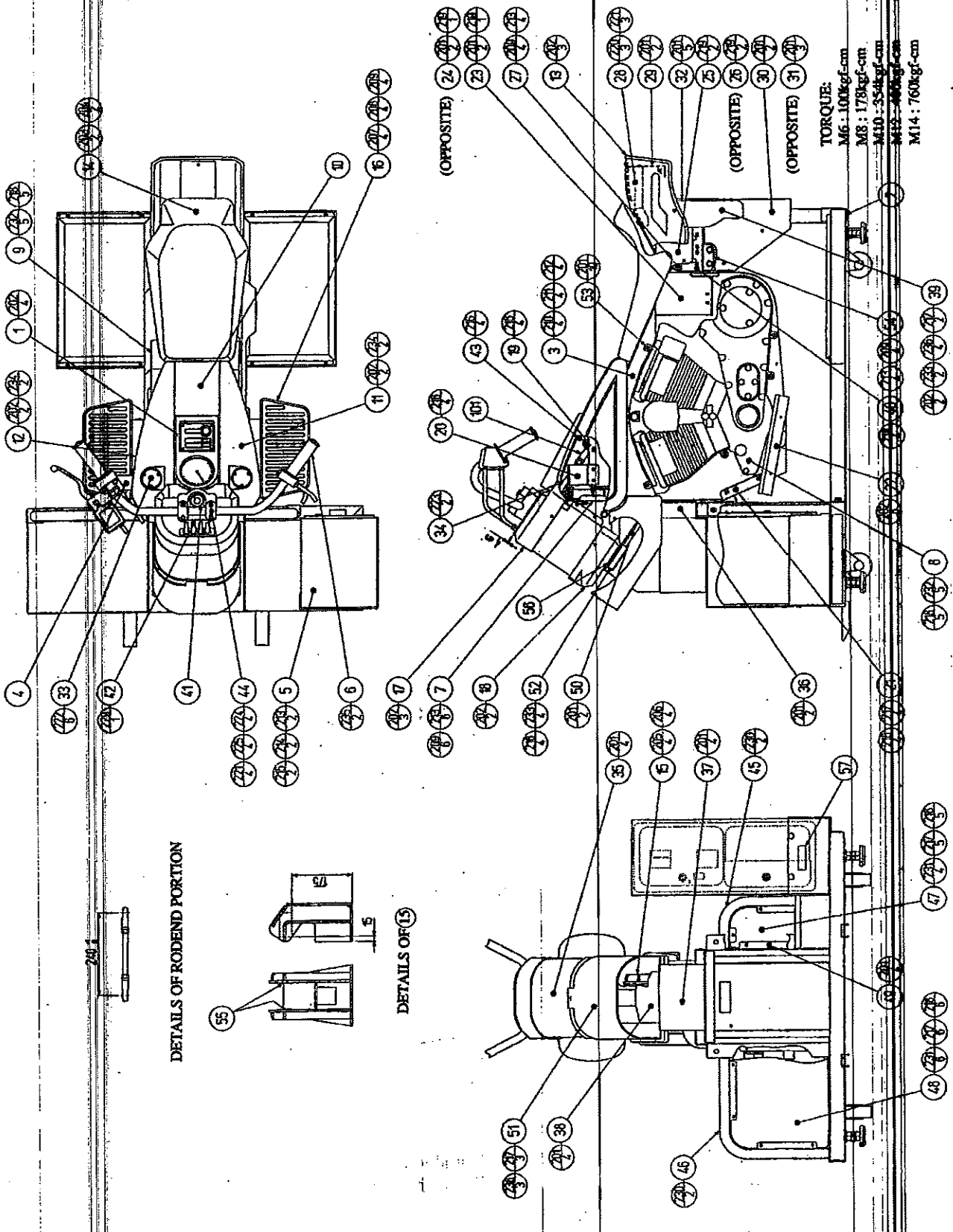

⑮ ASSY REAR CABINET (HLD-3000)

(D-2/3)

ITEM NO.	PART NO.	DESCRIPTION	NOTE
1	HLD-3080	ASSY SW PLATE	
2	HLD-3100	ASSY MECHA BASE	
3	HLD-3200	ASSY RIDE MECHA	
4	HLD-3300	ASSY FOOT BRAKE	
5	HLD-3500	ASSY COINCHUTE TOWER	
6	HLD-2000	ASSY HANDLE	
7	HLD-2100	ASSY HANDLE BASE	
8	HLD-3001	COVER ENGINE L	
9	HLD-3002	COVER ENGINE R	
10	HLD-3003	COVER TANK CENTER	
11	HLD-3004	COVER TANK L	
12	HLD-3005	COVER TANK R	
13	HLD-3006	REAR FENDER	
14	HLD-3007	SEAT	
15	HLD-3008	LINK BALL CASE	
16	HLD-3009	STEP	
17	HLD-3010	CENTER COVER	
18	HLD-3011	CENTER COVER LOWER	Xc 4
19	HLD-3012	TANK CENTER HOLDER A	Xc 4
20	HLD-3013	TANK CENTER HOLDER B	
21	HLD-3014	WIRE COVER	
22	HLD-3015	STEP EDGE	
23	HLD-3016	SPACE COVER A	
24	HLD-3017	SPACE COVER B	
25	HLD-3018	SPACE COVER C	
26	HLD-3019	SPACE COVER D	
27	HLD-3020	ROSTA HOLDER UPPER	
28	HLD-3021	REAR FENDER HOLDER A	
29	HLD-3022	REAR FENDER HOLDER B	
30	HLD-3023	COVER LOWER A	
31	HLD-3024	COVER LOWER B	
32	HLD-3025	COVER BEARING REAR	
33	HLD-3026	FUEL CAP	
34	HLD-3027	ROD M12	
35	HLD-3028	CENTER COVER HOLDER	
36	HLD-3029	COVER BEARING FRONT	
37	HLD-3030	COVER FRONT LOWER	
38	HLD-3031	COVER FRONT UPPER	
39	HLD-3032	SAFETY RUBBER REAR	
40	HLD-3033	SAFETY BLOCK	
41	HLD-3034	HANDLE WSHR	SE 11299
42	HLD-3035	HANDLE MOUNT	
43	HLD-3036	SW HOLDER	
44	MJT-3612	HANDLE HOLDER	
45	HLD-3037	PIPE L	
46	HLD-3038	PIPE R	
47	HLD-3039	GUARD PLATE L	
48	HLD-3040	GUARD PLATE R	
49	HLD-3041	PLATE HOLDER	
50	HLD-3042	COVER LID	
51	HLD-3045	SAFETY RUBBER FRONT	
52	HLD-3046	SAFETY BLOCK FRONT	X61

⑮ ASSY REAR CABINET (HLD-3000)

(D-3/3)

ITEM NO.	PART NO.	DESCRIPTION	NOTE
52	HLD-3047	BG MOUNT BRKT	
54	HLD-3108	ROSTA HOLDER LOWER	
55	GBN-2108	HOLE SHEBT	
56	HLD-3048	SPACBR FRONT	
101	100-5307	RODBND RBH12	
102	280-5009	CORD CLAMP 21	
103	601-5526-020	BUSH 1.6T	
201	000-T00408-0B	M SCR TH BLK M4×8	
202	000-T00412-0C	M SCR TH CRM M4×12	
203	030-000825-S	HEX BLT W/S M8×25	
204	068-852216	FLT WSHR 8.5-22×1.6	
205	030-001030-S	HEX BLT W/S M10×30	
206	060-F01000	FLT WSHR M10	
207	050-H00800	HEX NUT M8	
208	060-S00800	SPR WSHR M8	
209	060-F00800	FLT WSHR M8	
210	FAS-200005	HEX SKT H CAP SCR B OZ M14×40	
211	060-S01400	SPR WSHR M14	
212	060-F01400	FLT WSHR M14	
213	030-000820-S	HEX BLT W/S M8×20	
214	031-000620-0B	CRG BLT BLK M6×20	
215	050-F00600	FLG NUT M6	
216	000-P00408-W	M SCR PH W/FS M4×8	
217	000-T00412-0B	M SCR TH BLK M4×12	
218	068-441616-0B	FLT WSHR BLK 4.4-16×1.6	
219	000-P00412-W	M SCR PH W/FS M4×12	
220	030-000620-S	HEX BLT W/S M6×20	
221	060-F00600-0B	FLT WSHR BLK M6	
222	000-T00416-0C	M SCR TH CRM M4×16	
223	050-H01200	HEX NUT M12	
224	020-000620-0Z	HEX SKT H CAP SCR BLK OZ M6×20	
225	060-S00600-0B	SPR WSHR BLK M6	
226	050-H00400	HEX NUT M4	
227	060-F00400	FLT WSHR M4	
228	060-S00400	SPR WSHR M4	
229	FAS-300019	HEX BLT CRM W/S M10×20	
230	FAS-300001	HEX BLT CRM W/FS M8×20	
231	050-C00400-3B	CAP NUT TYPE 3 BLK M4	
232	000-P00412-WB	M SCR PH W/FS BLK M4×12	
233	050-F00400	FLG NUT M4	
234	068-441616-0C	FLT WSHR CRM 4.4-16×1.6	
235	FAS-110002	TAP SCR TH 4×20	
236	068-552016-0B	FLT WSHR BLK 5.5-20×1.6	
301	600-6984-025-91	WIRB HARN RIDE MECHA3	

①⑥ ASSY SW PLATE (HLD-3080)

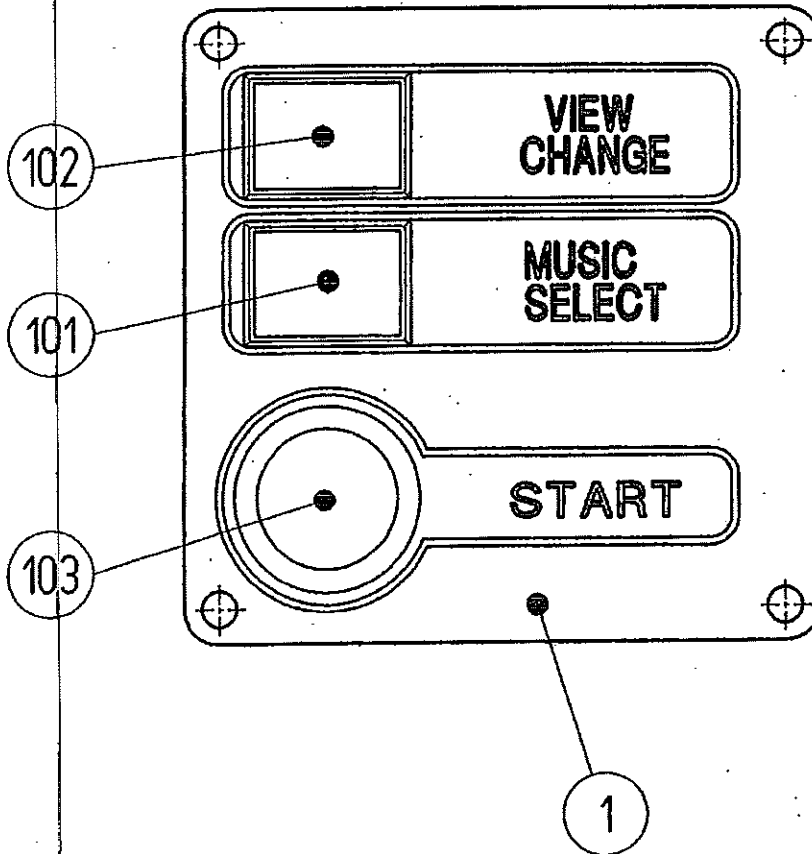

ITEM NO.	PART NO.	DESCRIPTION	NOTE
1	HLD-3081	SW PLATE	
101	509-5779-BL	SW PB W/LAMP 6V BLUE	
102	509-5779-GR	SW PB W/LAMP 6V GREEN	
103	509-0161	SW PB TYPE 1T YBL W/LAMP	
104	280-5009	CORD CLAMP 21	
105	601-0460	PLASTIC TIE BELT 100MM	
301	600-6984-026	WIRE HARN SW PLATE	

①7 ASSY MECHA BASE (HLD-3100)

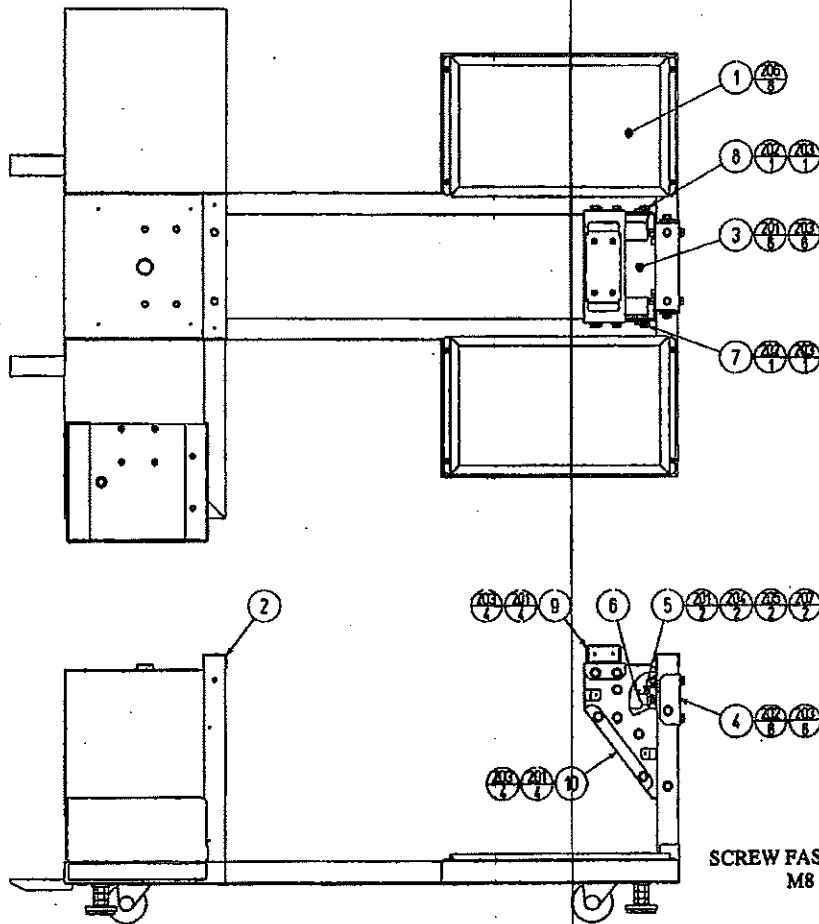

SCREW FASTENING TORQUE TO BE
M8 : 178 kgf-cm

ITEM NO.	PART NO.	DESCRIPTION	NOTE
1	HLD-3150	ASSY STEP	
2	HLD-3101	BIKE BASE	
3	HLD-3102	STOPPER BRKT A	
4	HLD-3103	STOPPER BRKT B	
5	HLD-3104	STOPPER SHAFT	
6	HLD-3105	STOPPER RUBBER R	
7	HLD-3106	ROSTA BASE L	
8	HLD-3107	ROSTA BASE R	
10	HLD-3109	ROSTA BASE CENTER	
101	280-5009	CORD CLAMP 21	
201	030-000820-S	HEX BLT W/S M8×20	
202	030-000860-S	HEX BLT W/S M8×60	
203	060-F00800	FLT WSHR M8	
204	060-S00800	SPR WSHR M8	
205	050-U00800	U NUT M8	
206	000-T00408-0C	M SCR TH CRM M4×8	
207	068-852216	FLT WSHR 8, 5-22×1.6	
301	600-6984-021	WIRE HARN BASE EXT1	

⑱ ASSY STEP (HLD-3150)

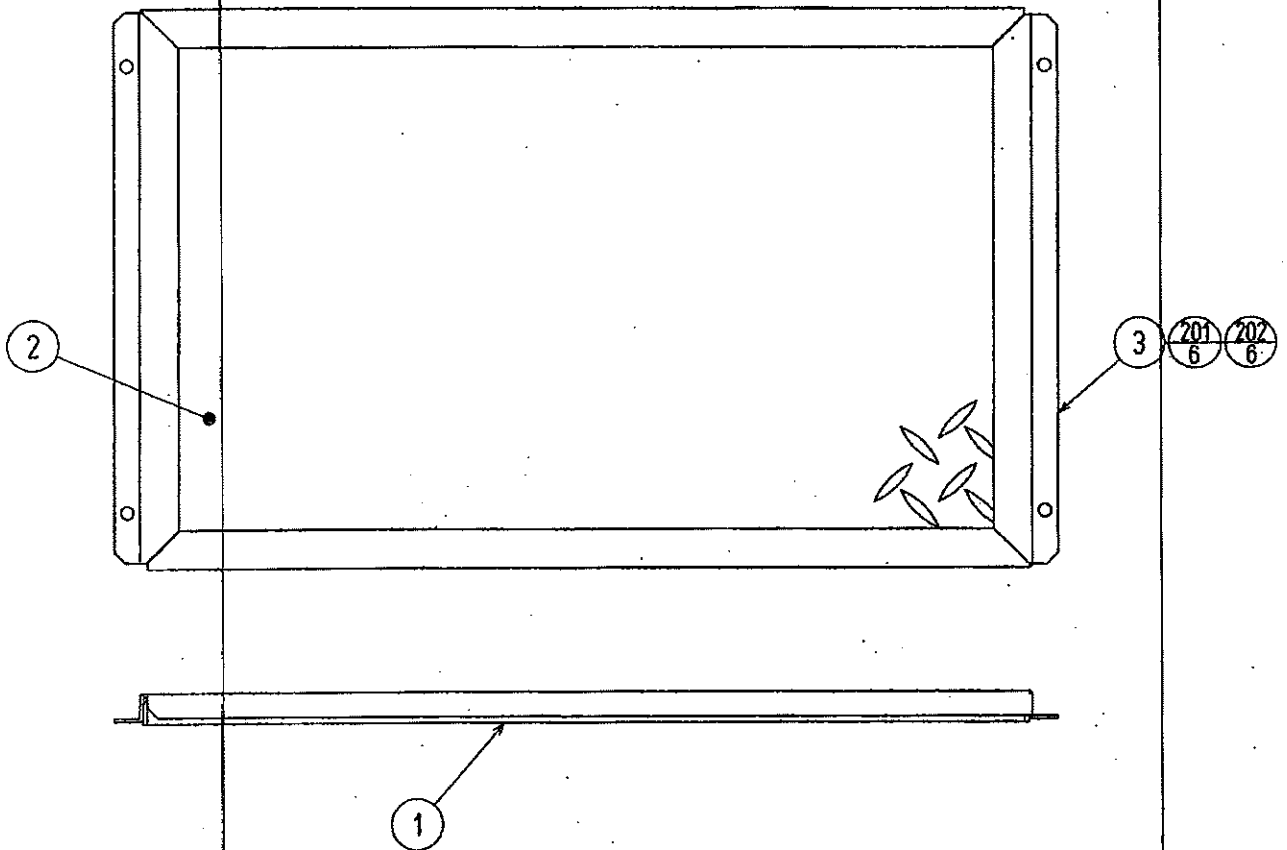

ITBM NO.	PART NO.	DESCRIPTION	NOTE
1	HLD-3151	STEP	
2	HLD-3152	STEP MAT	
3	HLD-3153	STEP BRKT	
201	050-U00400	U NUT M4	
202	060-F00400	PLT WSHR M4	

①9 ASSY RIDE MECHA (HLD-3200)

(D-1/2)

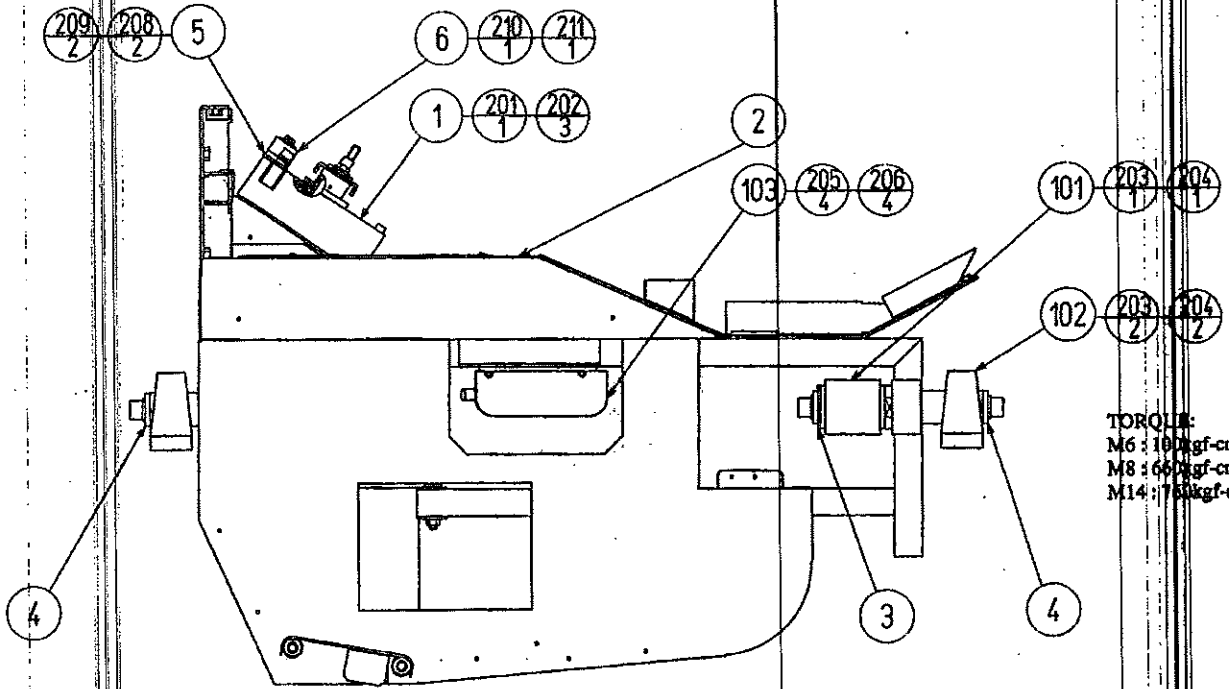

①9 ASSY RIDE MECHA (HLD-3200)

(D-2/2)

ITEM NO.	PART NO.	DESCRIPTION	NOTE
1	HLD-3250	ASSY ROLL BRAKE	
2	HLD-3201-N	BIKE FRAME	
3	HLD-3202	ROSTA WASHBR	
4	TTR-3205	FLT 14.5-36×3.2	
5	HLD-3043	SAFETY BRKT	
6	HLD-3044	SAFETY RUBBER	
101	601-10004	ROSTA 38×60	
102	100-5224	BEARING 25 PYH UCP305	
103	130-5172	BASS SHAKER	
104	280-5009	CORD CLAMP 21	
201	FAS-200014	HEX SKT H CAP SCR BLK OZ M8×45	
202	060-S00800	SPR WSHR M8	
203	030-001425-0B	HEX BLT BLK M14×25	
204	060-S01400-0B	SPR WSHR BLK M14	
205	060-F00400	FLT WSHR M4	
206	050-U00400	U NUT M4	
207	000-P00412-W	M SCR PH W/FS M4×12	
208	FAS-200020	HEX SKT H CAP SCR BLK OZ M8×80	
209	060-F00800	FLT WSHR M8	
210	030-000620-S	HEX BLT W/S M6×20	
211	068-652016	FLT WSHR 6.5-20×1.6	
301	600-6984-034	WIRE HARN RIDE MECHA EXT	
302	600-6984-039	WIRE HARN E RIDE MECHA2	
303	600-6984-030	WIRE HARN BASS SHAKER R	

②① ASSY ROLL BRAKE (HLD-3250)

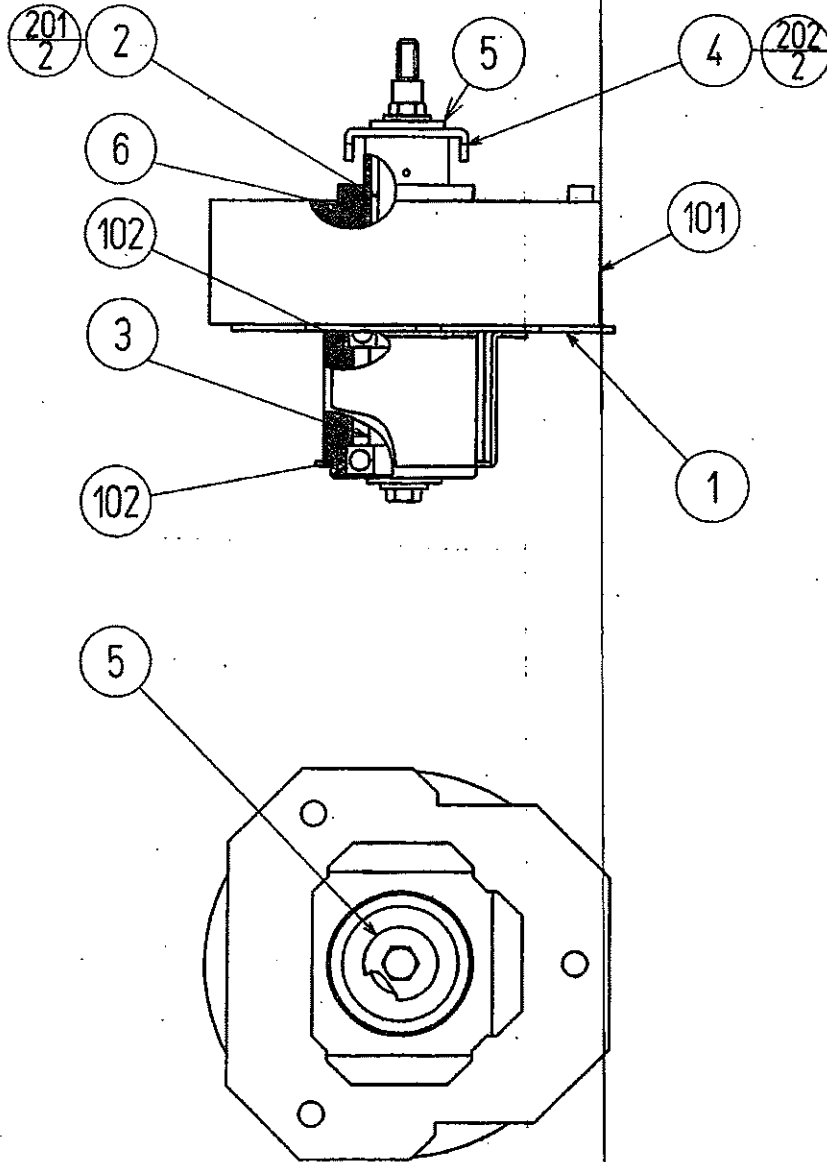

TORQUE:
M8 : 178kgf-cm

ITEM NO.	PART NO.	DESCRIPTION	NOTE
1	HLD-3251	BRAKE MOUNT HOLDER	
2	HLD-3252	BRAKE SHAFT	
3	HLD-3253	BRAKE COLLAR	
4	HLD-3254	CRANK B	
5	HLD-3255	BRAKE WSHR	
6	HLD-3256	KBY 7×7×55	
101	601-10005	BRAKE BXH-16A	
102	100-5266	BBARING FA125	
201	030-000820-S	HEX BLT W/S M8×20	
202	028-A00308-P	SBT SCR-HEX SKT CUP P M3×8	

②1 ASSY FOOT BRAKE (HLD-3300)

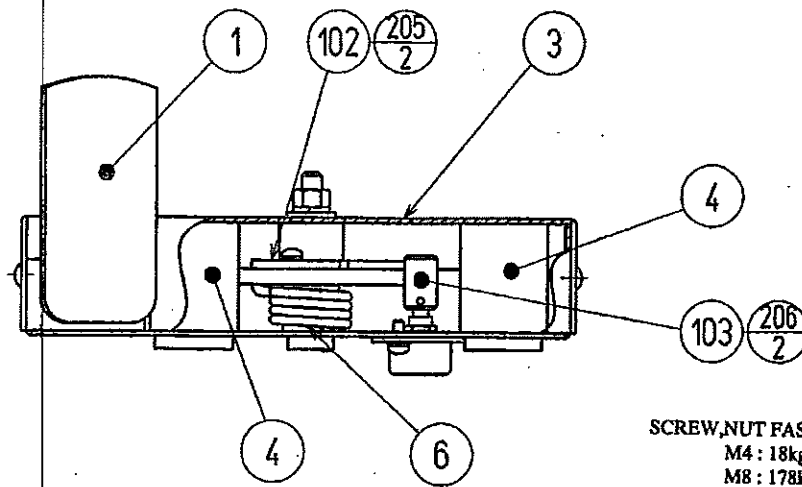

SCREW,NUT FASTENING TORQUE TO BE
M4 : 18kgf-cm
M8 : 178kgf-cm

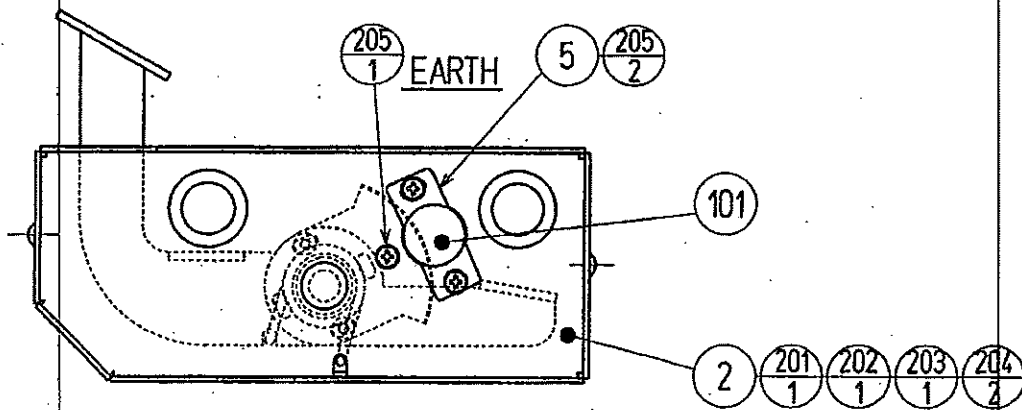

ITEM NO.	PART NO.	DESCRIPTION	NOTE
1	HLD-3301	BRAKE PEDAL	
2	HLD-3302	BRAKE BASE	
3	HLD-3303	BRAKE BASE LID	
4	HLD-3304	STOPPER RUBBER	
5	HLD-3305	VR BRKT	
6	HLD-3306	TORSION SPRING	
101	220-5373	VOL CONT B-5K	
	220-5484	VOL CONT B-5K OHM	
102	601-6450	GEAR 110	
103	601-7944	GEAR 15	
104	310-5029-F20	SUMI TUBE F F 20MM	
201	050-H00800-0B	HEX NUT BLK M8	
202	060-S00800-0B	SPR WSHR BLK M8	
203	060-F00800-0B	FLT WSHR BLK M8	
204	000-T00408-0B	M SCR TH BLK M4×8	
205	000-P00412-W	M SCR PH W/FS M4×12	
206	028-A00308-P	SET SCR HEX SKT CUP P M3×8	
301	600-6984-027	WIRE HARN REAR BRAKE	

22 ASSY COINCHUTE TOWER (HLD-3500)

(D-1/2)

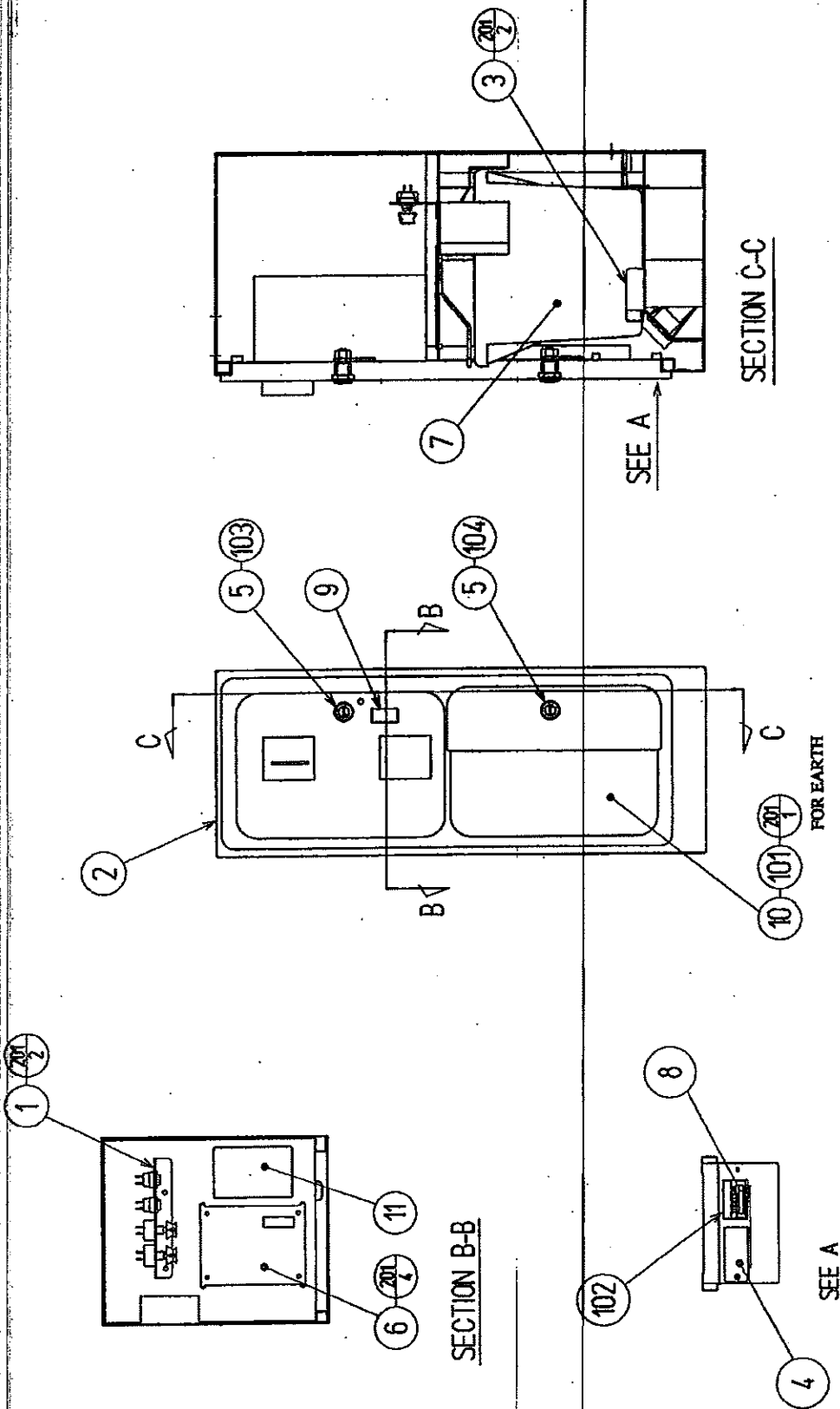

② ASSY COINCHUTE TOWER (HLD-3500)

(D-2/2)

ITEM NO.	PART NO.	DESCRIPTION	NOTE
1	HLD-3550	SW UNIT	
2	HLD-3501	COINCHUTE TOWER	
3	INY-1162	METER BRKT	
4	INY-1163	METER HOLE LID	
5	DP-1167	TNG LKG	
6	105-5171	CHUTE PLATE SINGLE	
7	253-5366	CASH BOX	
8	421-6591-01	STICKER COIN METER	
10	421-7501-02	STICKER 6.3V 0.15A	
11	440-WS0002XEG	STICKER W POWBR OFF ENG	
101	220-5482-91- ~	ASSY C. C 2DR ~	
	220-5237-92- ~	ASSY C. C 2DR ~	
102	220-5412	MAG CNTR W/CONN	
103	220-5575	CAM LOCK MASTER W/O KBY	
104	220-5574	CAM LOCK W/KBYS	
105	280-5009	CORD CLAMP 21	
106	280-5275-SR10	CORD CLAMP SR10	
107	310-5029-F20	SUMI TUBE F F 20MM	
108	601-0460	PLASTIC TIE BBLT 100MM	
201	000-P00408-W	M SCR PH W/FS M4×8	
301	600-6455-02	WIRE HARN C. C DOOR SINGLE	
302	600-6709-52	WIRE HARN BARTH 400MM	
303	600-6709-54	WIRE HARN BARTH 150MM	
304	600-6984-024	WIRE HARN COINCHUTE TOWER1	

23 SW UNIT (HLD-3550)

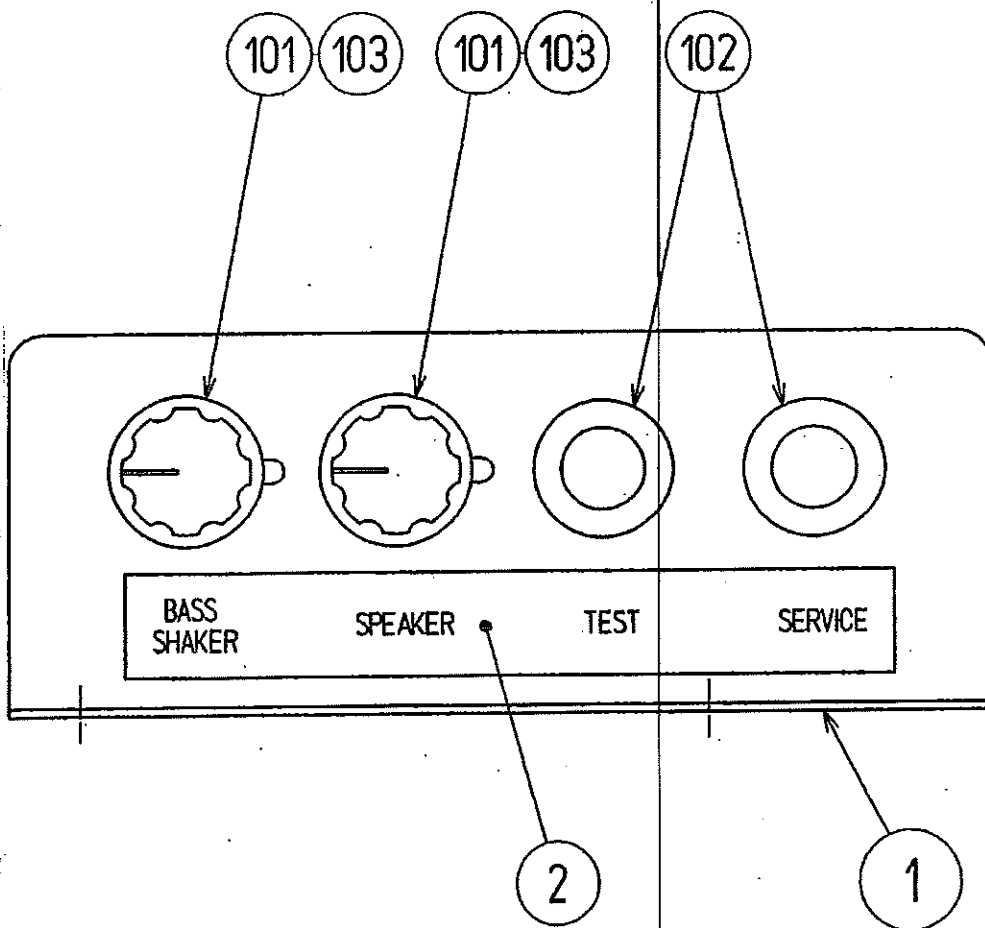

ITEM NO.	PART NO.	DESCRIPTION	NOTE
1	INV-1181	SW BRKT	
2	421-9590	STICKER SW UNIT	
101	220-5179	VOL CONT B-5K OHM	
102	509-5028	SW PB 1M	
103	601-0042	KNOB 22MM	
104	310-5029-D20	SUMI TUBE F D 20MM	
105	601-0460	PLASTIC TIE BELT 100MM	
301	600-6609-32	WIRE HARN TEST & SERVICE	
302	600-6609-33	WIRE HARN VOLUME A	
303	600-6609-34	WIRE HARN VOLUME B	

②④ ASSY HANDLE (HLD-2000)

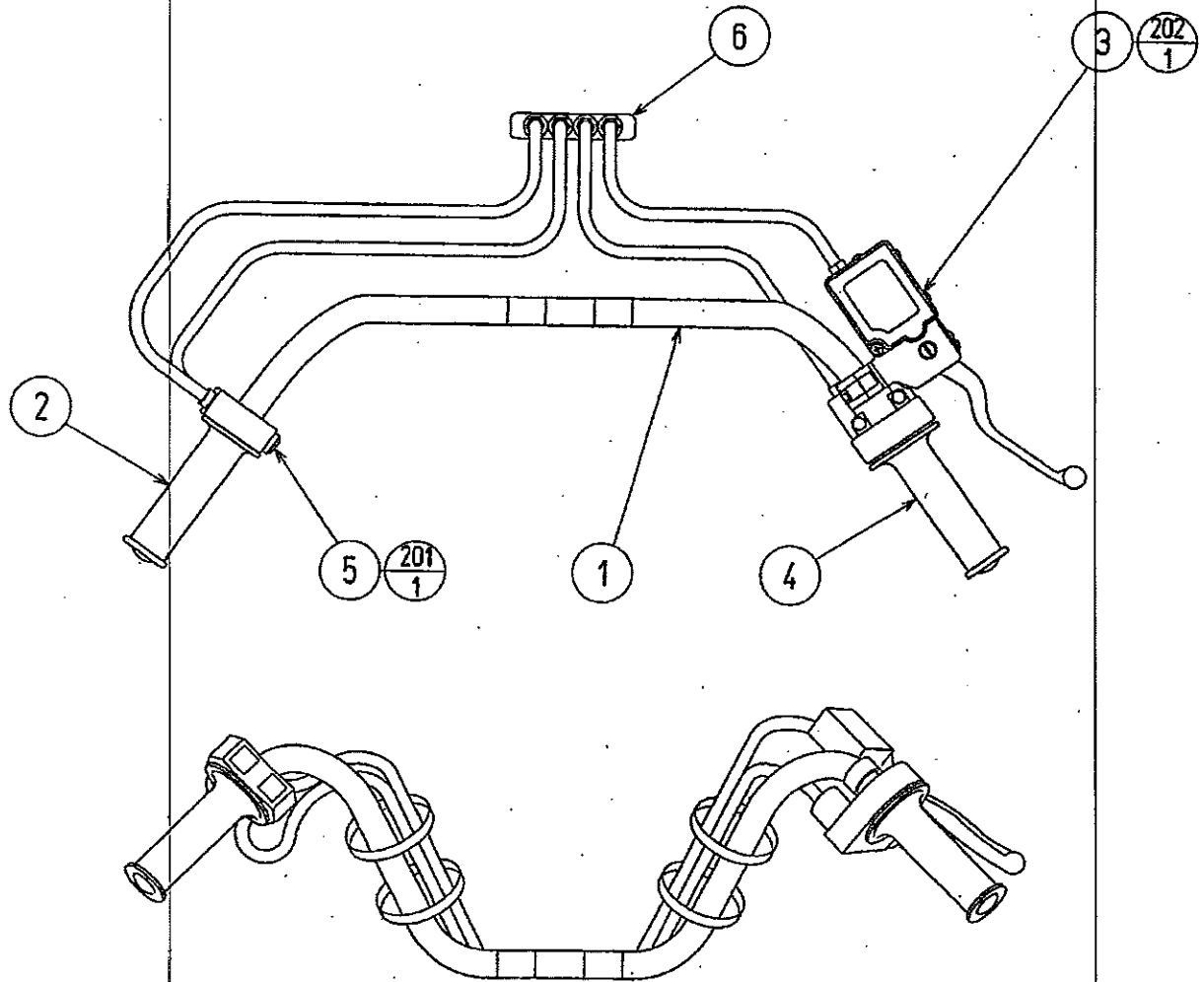

SCREW FASTENING TORQUE TO BE
M4 : 18kgf-cm
③④ : 100kgf-cm

ITEM NO.	PART NO.	DESCRIPTION	NOTE
1	HLD-2001	HANDLE BAR	
2	HLD-2002	GRIP LEFT	
3	HLD-2500	ASSY BRAKE MECHA	
4	HLD-2600	ASSY THROTTLE	
5	HLD-2700	ASSY SHIFT SWITCH	
6	HLD-2003	PLATE PROTECT TUBE	
101	601-6788	PLASTIC TIE BELT BLACK 4.8×188	
201	000-T00420-0B	M SCR TH BLK M4×20	
202	000-T00412-0B	M SCR TH BLK M4×12	

25 ASSY BRAKE MECHA (HLD-2500)

(D-1/2)

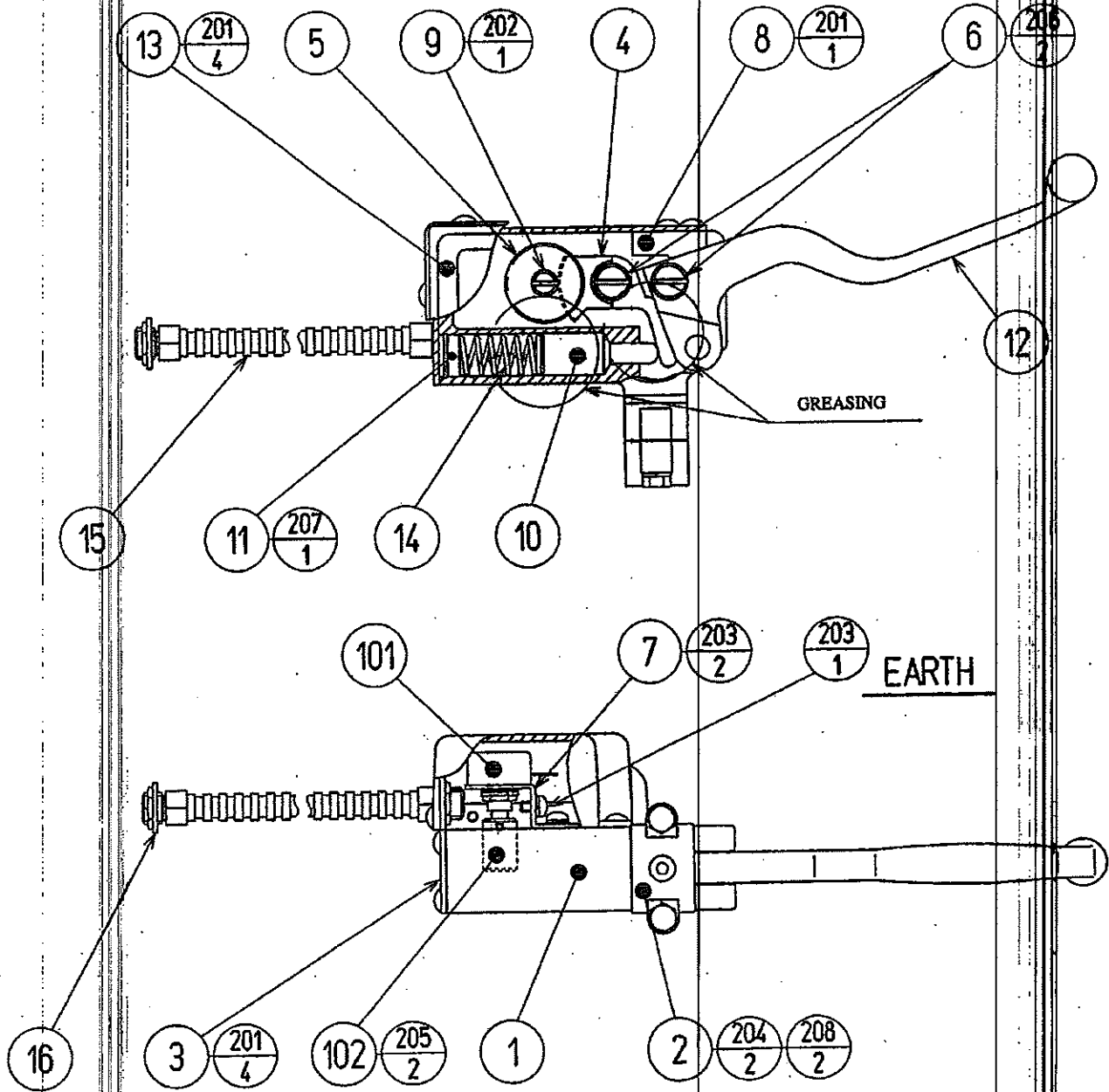

NOTE 1. SCREW,NUT FASTENING TORQUE TO BE
 M4 :18kgf-cm
 M6 :73kgf-cm

APPLY GREASING TO ALL OF THE GEAR & SLIDING PORTIONS.

②5 ASSY BRAKE MECHA (HLD-2500)

(D-2/2)

ITEM NO.	PART NO.	DESCRIPTION	NOTE
1	HLD-2501	BRAKE MASTER CASE	
2	HLD-2502	MASTER CASE HOLDER	
3	HLD-2503	MASTER CASE COVER	
4	HLD-2504	BRAKE GEAR	
5	HLD-2505	IDOL GEAR	
6	HLD-2506	PIVOT SHAFT	
7	HLD-2507	VR BRKT	
8	HLD-2508	LEVER STOPPER	
9	HLD-2509	IDOL GEAR SHAFT	
10	HLD-2510	MASTER PISTON	
11	HLD-2511	END CAP	
12	HLD-2512	BRAKE LEVER	
13	HLD-2513	VR COVER	
14	HLD-2514	RETURN SPRING	
15	601-10023	PROTECT TUBE	
16	HLD-2004	TUBE WSHR	
101	220-5484	VOL CONT B-5K OHM	
102	601-7944	GEAR 15	
103	310-5029-F20	SUMI TUBE F F 20MM	
104	280-5275-SR10	CORD CLAMP SR10	
201	000-T00408-0B	M SCR TH BLK M4×8	
202	050-C00400-3B	CAP NUT TYPE3 BLK M4	
203	000-P00408-W	M SCR PH W/FS M4×8	
204	030-000620-SB	HEX BLT W/S BLK M6×20	
205	028-A00306-P	SBT SCR HEX SKT CUP P M3×6	
206	FAS-500015	CAP NUT BLK M6	
207	065-S016H0-Z	STP RING BLK OZ M16	
208	060-F00600-0B	FLT WSHR BLK M6	
301	600-6984-033	WIRE HARN FRONT BRAKE	

② ASSY THROTTLE (HLD-2600)

(D-2/2)

ITEM NO.	PART NO.	DESCRIPTION	NOTE
1	HLD-2601	THROTTLE CASE LOWER	
2	HLD-2602	THROTTLE CASE UPPER	
3	HLD-2603	INNER GRIP	
4	HLD-2604	ACCEL GEAR	
5	HLD-2605	BASE PLATE	
6	HLD-2606	ACCEL GEAR SHAFT	
7	HLD-2607	ACCEL VR BRKT	
8	HLD-2608	SPRING HOOK	
9	HLD-2609	RETURN SPRING	
10	HLD-2610	VR COVER	
11	HLD-2611	ACCEL GRIP	
12	HLD-2612	SLIDE PLATE	
13	601-10023	PROTECT TUBE	
14	HLD-2613	SPRING STOPPER	
15	HLD-2614	GEAR SPRING	
16	HLD-2004	TUBE WSHR	
101	220-5484	VOL CONT B-5K OHM	
102	601-7944	GEAR 15	
103	310-5029-F20	SUMI TUBE F F 20MM	
201	000-T00408-0B	M SCR TH BLK M4×8	
202	000-P00408-W	M SCR PH W/FS M4×8	
203	000-F00408	M SCR PH M4×8	
204	030-000625-SB	HEX BLT W/S BLK M6×25	
205	060-F00600-0B	FLT WSHR BLK M6	
207	028-A00306-P	SET SCR HEX SKT CUP P M3×6	
208	012-P00306	TAP SCR #2 PH 3×6	
301	600-6984-032	WIRE HARN THROTTLE	

(27) ASSY SHIFT SWITCH (HLD-2700)

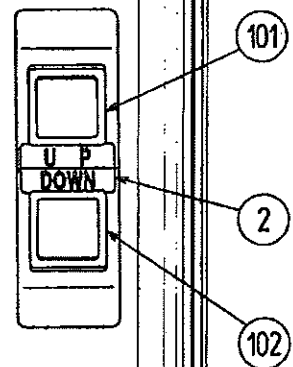
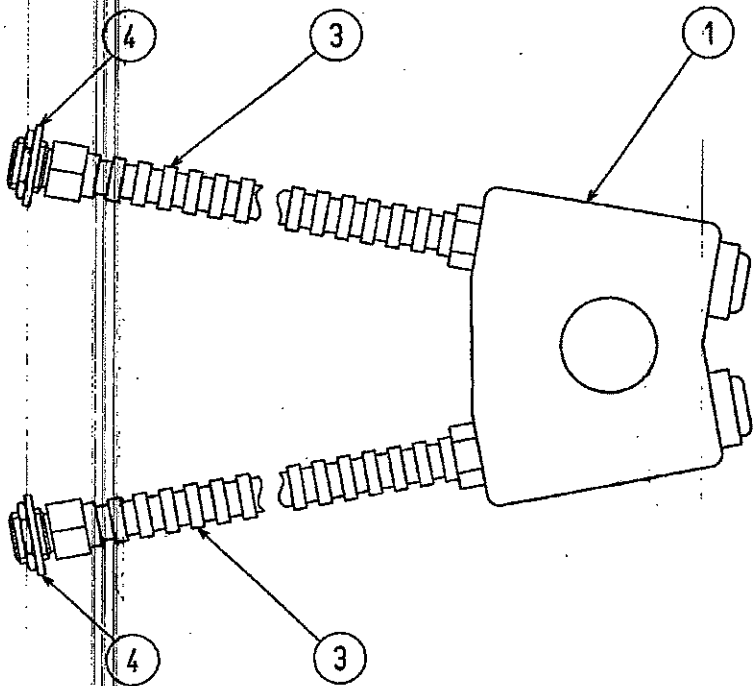

ITEM NO.	PART NO.	DESCRIPTION	NOTE
1	HLD-2701	SWITCH CASE	
2	421-7752	STICKER UP DOWN	
3	601-10024-01	PROTECT TUBE EX S	
4	HLD-2004	TUBE WSHR	
101	509-5003	SW PB TYPE 1T GREEN 14.2	
102	509-5003-03	PB SW RED	
301	600-6985-046	WIRE HARN SHIFT SW STD	

28 ASSY HANDLE BASE (HLD-2100)

(D-1/2)

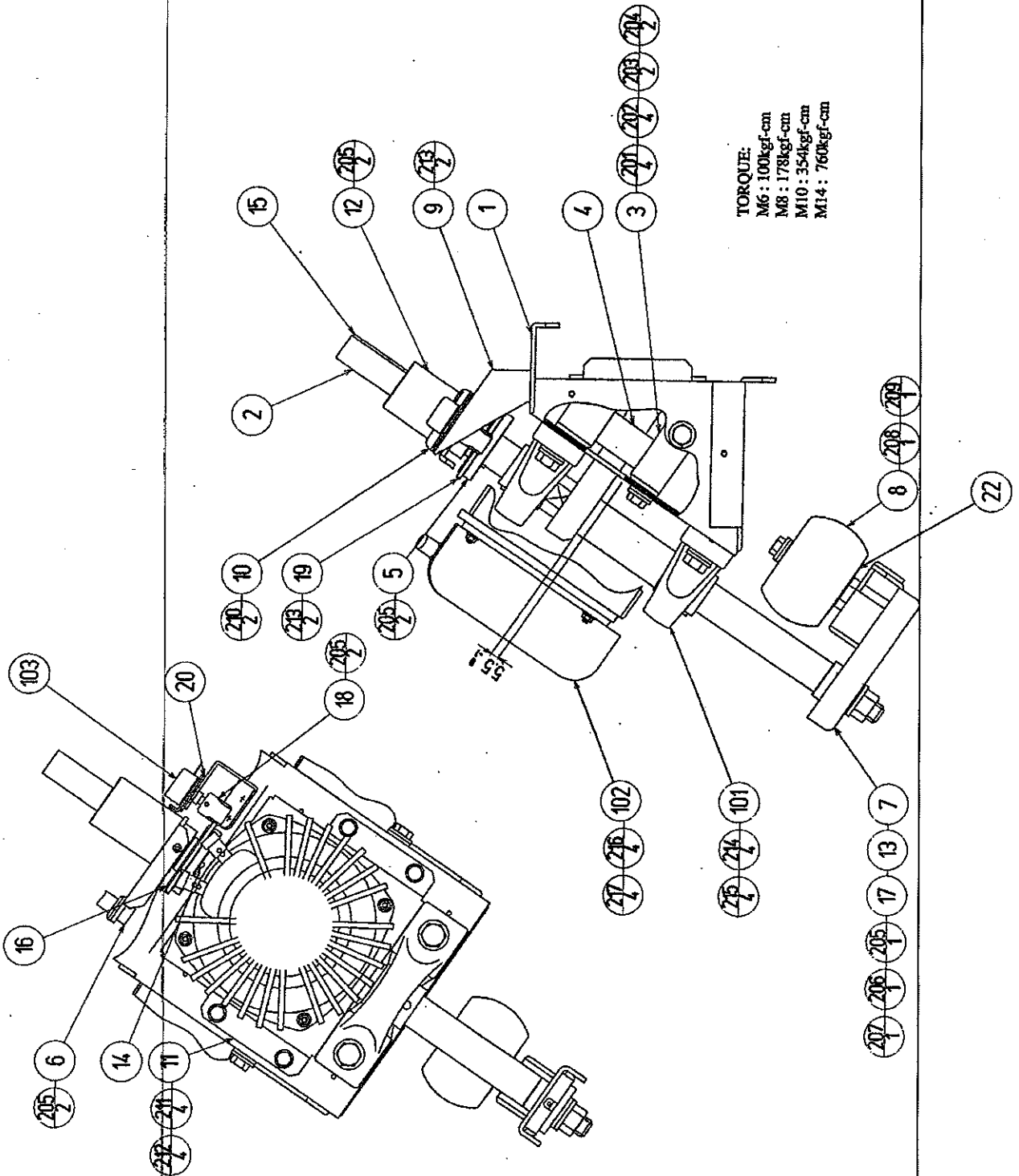

28 ASSY HANDLE BASE (HLD-2100)

(D-2/2)

ITEM NO.	PART NO.	DESCRIPTION	NOTE
1	HLD-2101	HANDLE BASE	
2	HLD-2102	HANDLE SHAFT	
3	HLD-2103	HANDLE STOPPER	
4	HLD-2104	STOPPER RUBBER H	
5	HLD-2105	GEAR HOLDER	
6	HLD-2106	CRANK A	
7	HLD-2107X	HANDLE CRANK	
8	HLD-2108	ROLLER	
9	HLD-2109	VR MOUNT BRKT	
10	HLD-2110	VR BRKT	
11	HLD-2111	BASS BRKT	
12	HLD-2112	HANDLE COLLAR	
13	HLD-2113	KBY 5×5×15	
14	HLD-2114	KBY 5×5×20	
15	HLD-2115	KBY 5×5×65	
16	HLD-2116	GEAR PLATE	
17	TTR-3205	FLT 14.5-36×3.2	
18	601-7945	GEAR 20	
19	601-10003	GEAR 80	
20	HLD-2117	SPACER	
22	HLD-2118	WASHER 20.1	
101	100-5306	BEARING 25	
102	130-5172	BASS SHAKER	
103	220-5373	VOL CONT B-5K	
	220-5484	VOL CONT B-5K OHM	
104	310-5029-F20	SUMI TUBE F F 20MM	
201	030-000820-SB	HEX BLT W/S BLK M8×20	
202	060-F00800-OB	FLT WSHR BLK M8	
203	060-S00800	SPR WSHR M8	
204	050-U00800	U NUT M8	
205	028-A00308-P	SET SCR HEX SKT CUP P M3×8	
206	050-H01400	HEX NUT M14	
207	060-S01400	SPR WSHR M14	
208	030-001020-S	HEX BLT W/S M10×20	
209	068-A52820	FLT WSHR 10.5-28×2	
210	000-P00408-W	M SCR PH W/FS M4×8	
211	060-F00600	FLT WSHR M6	
212	030-000620-S	HEX BLT W/S M6×20	
213	000-P00412-S	M SCR PH W/S M4×12	
214	060-F01000	FLT WSHR M10	
215	030-001040-S	HEX BLT W/S M10×40	
216	060-F00400	FLT WSHR M4	
217	050-U00400	U NUT M4	
301	600-6984-028	WIRE HARN STEERING	
302	600-6984-029	WIRE HARN BASS SHAKER F	

21. WIRE COLOR CODE TABLE

THE WIRE COLOR CODE is as follow:

A	PINK
B	SKY BLUE
C	BROWN
D	PURPLE
E	LIGHT GREEN

Wires other than those of any of the above 5 single colors will be displayed by 2 alphanumeric characters.

1	RED
2	BLUE
3	YELLOW
4	GREEN
5	WHITE
7	ORANGE
8	BLACK
9	GRAY

If the right-hand side numeral of the code is 0, then the wire will be of a single color shown by the left-hand side numeral (see the above).

Note 1: If the right-hand side alphanumeric is not 0, that particular wire has a spiral color code. The left-hand side character shows the base color and the right-hand side one, the spiral color.

<Example> 51 WHITE / RED

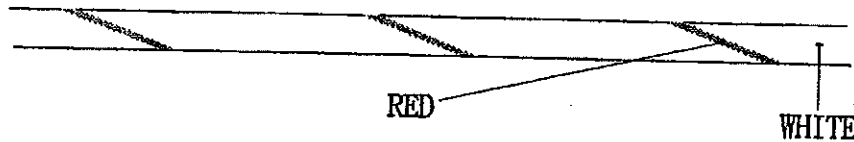

Note 2: The character following the wire color code indicates the size of the wire.

K:	AWG18, UL1015
L:	AWG20, UL1007
None:	AWG22, UL1007

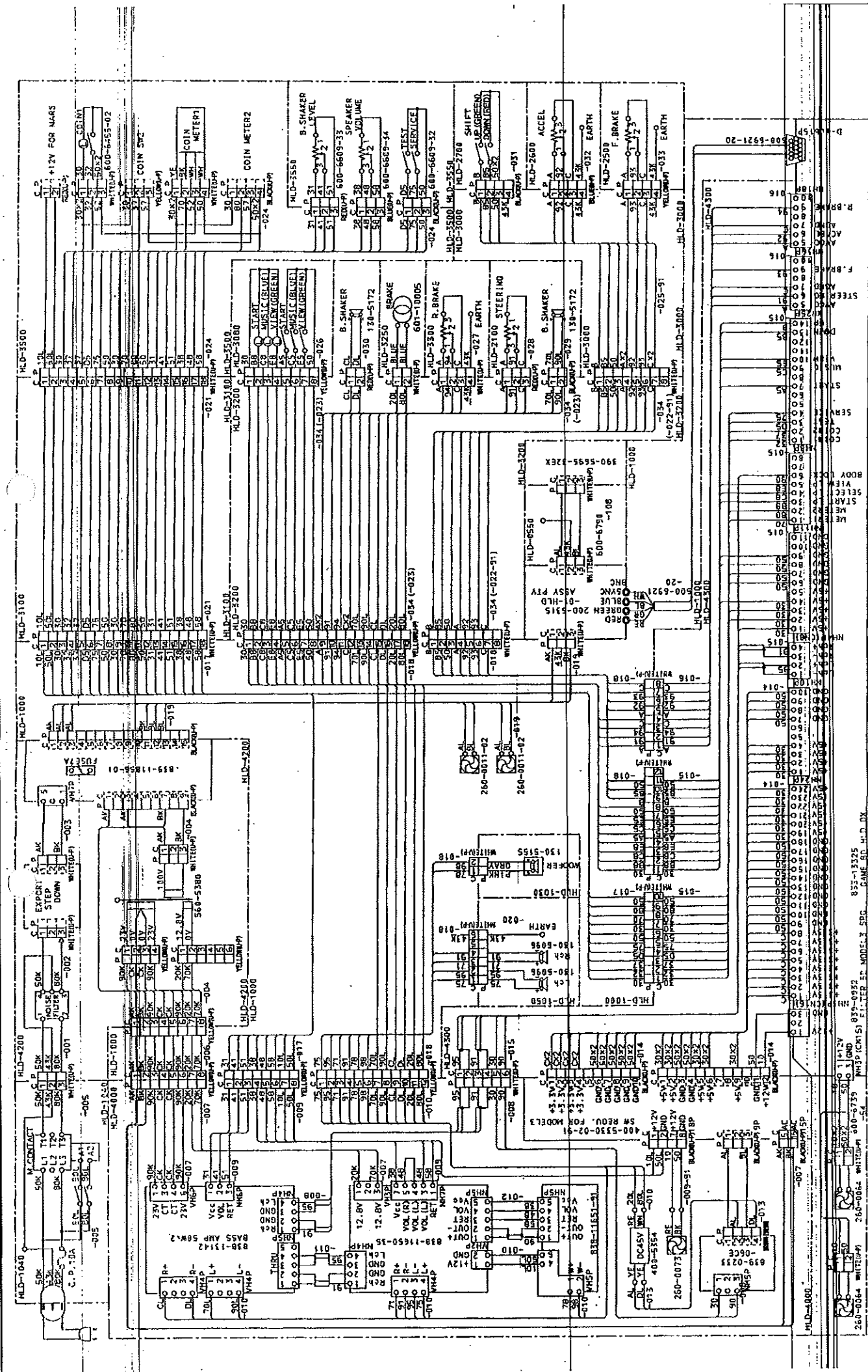

22. WIRING DIAGRAM (D-1/2)

