

T.M.

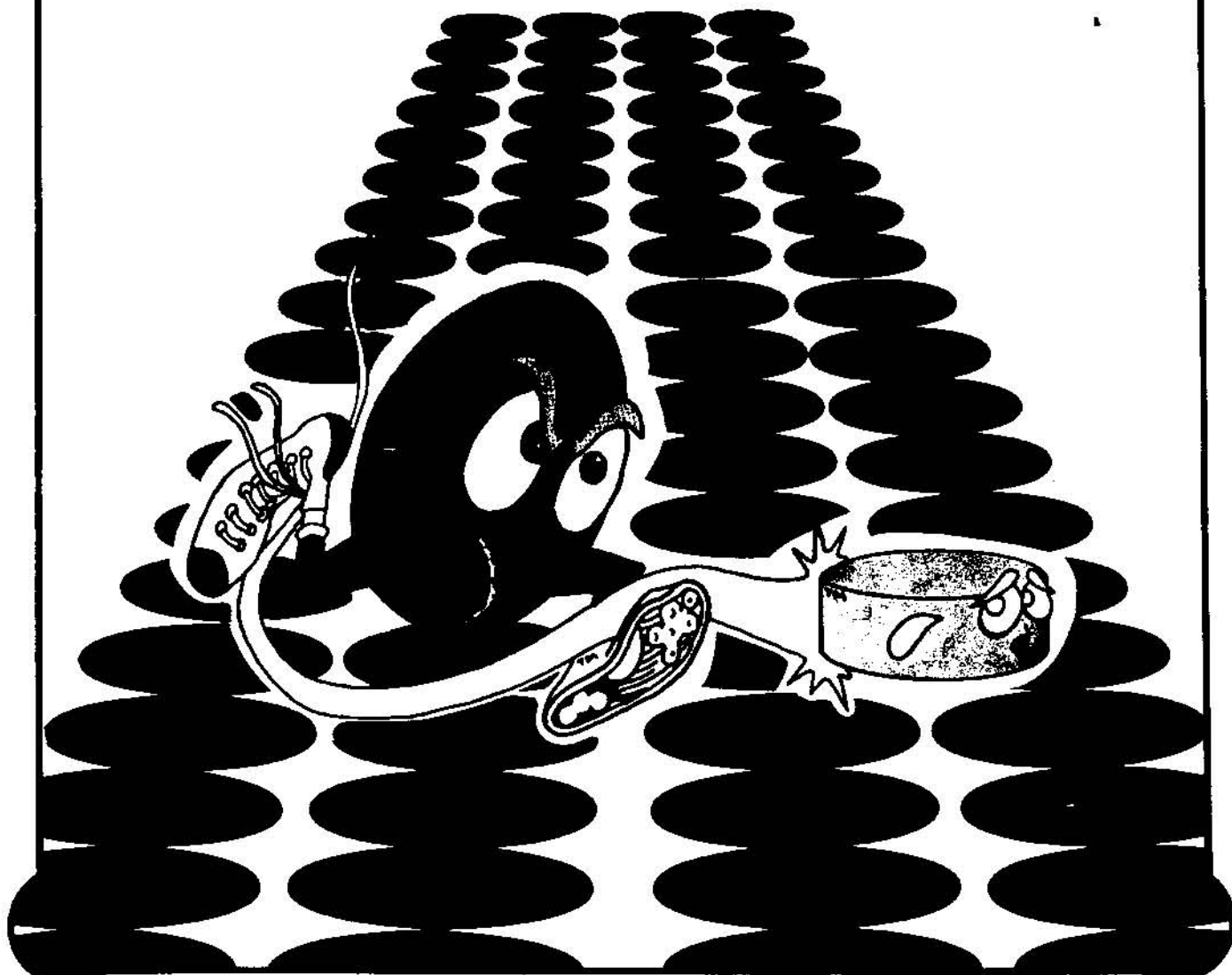

© 1982

Trade Marks of Taito America Corporation

72-00017-001



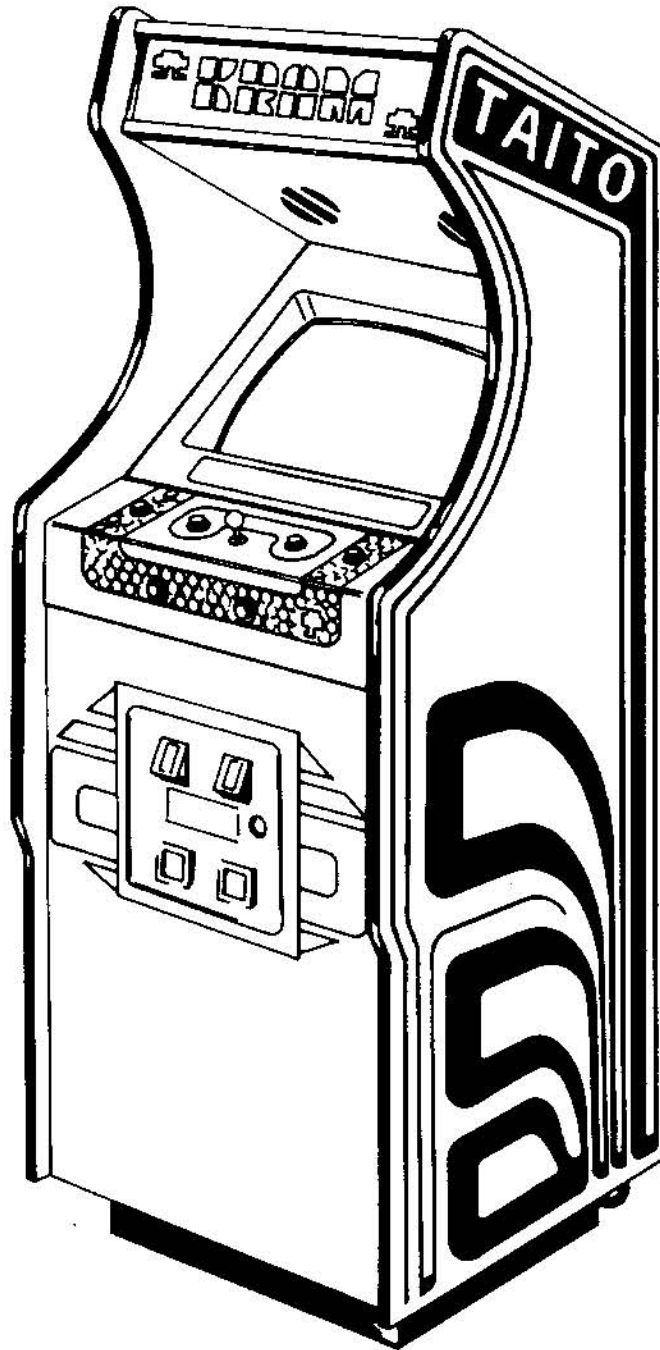



1256 Estes Avenue, Elk Grove Village, IL 60007
Telephone (312) 981-1000 Telex 25-3290

‘ ‘KRAM’ ’™

OPERATION, MAINTENANCE AND SERVICE MANUAL
Complete with Illustrated Parts Catalog

LIST OF ILLUSTRATIONS

Figure 1-1	Programming Plug	6
Figure 1-2	Power ON/OFF Switch	7
Figure 1-3	Interlock Switches & Memory Protect Switch	7
Figure 1-4	Self Test Switches	7
Figure 1-5	Volume Control Setting	7
Figure 1-6	Door Switches	8
Figure 1-7	Video Board (On Back of Service Door)	9
Figure 1-8	Flow Chart	10
Figure 1-9	Color Bar	10
Figure 1-10	Color Bar	11
Figure 1-11	Color Bar	11
Figure 2-1	Coin Door	16
Figure 2-2	Fuse Replacement	16
Figure 2-3	Monitor Removal	16
Figure 2-4	Cover Glass Removal	17
Figure 2-5	Printed Circuit Board	17
Figure 2-6	Power Supply	17
Figure 2-7	Current Limit Adjustment	18
Figure 3-1	Clock Timing	22
Figure 3-2	Dual Port RAM Timing	23

LIST OF TABLES

Table 1-1	Self Test Switches	7
Table 1-2	Hardware Tests	8
Table 1-3	Video Board ROM Checksum	8
Table 1-4	Decoding Jumper Location	8
Table 1-5	Video Board RAM Checksum	9
Table 1-6	Data/Sound Board ROM Checksum	9
Table 1-7	Screen ROM Content	10
Table 1-8	Audit Totals	12
Table 1-9	Standard Coin Setting	13
Table 1-10	Custom Coin Setting	13
Table 2-1	Line Voltage	17
Table 2-2	Secondary Fuses	18
Table 2-3	Video Board Test Points	19
Table 3-1	Video Board Memory Map	22
Table 3-2	Register Initialization	23
Table 2-3	Data/Sound Memory Map	24

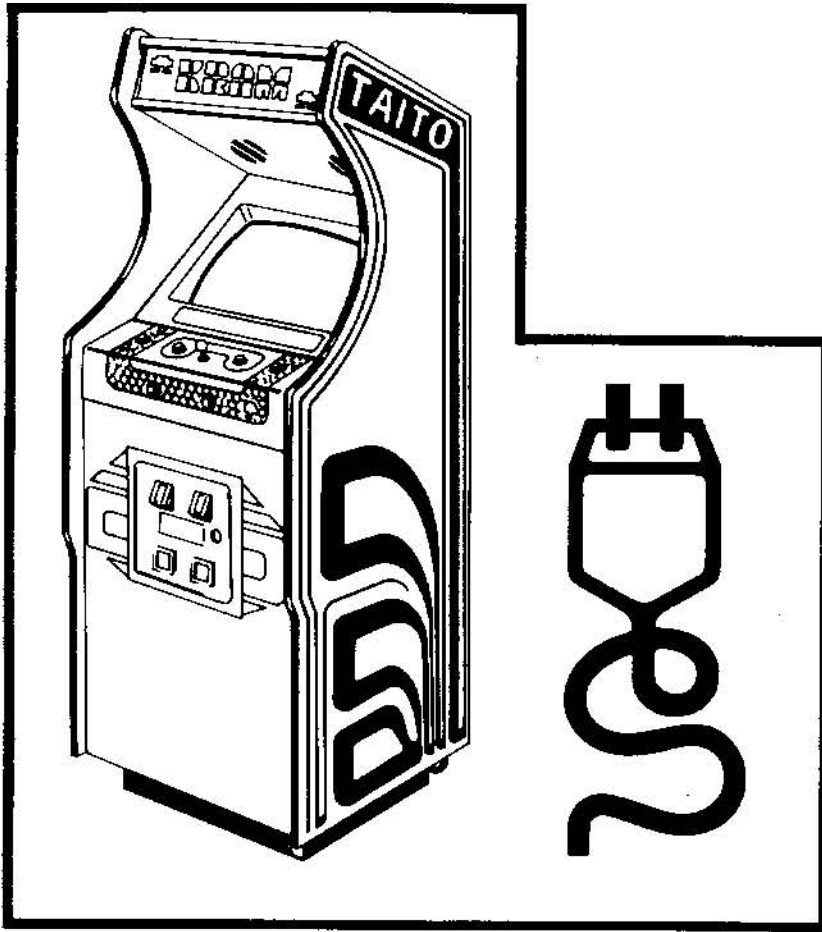

Game Set-Up

1

1.8 SELF TEST PROCEDURE

1.8.1 GENERAL

The Self Test Procedure is performed using the two(2) Switches located on the inside of the Coin Door, and the Self Test Button and the LED's on the Video PC Board. (See Figure 1-6).

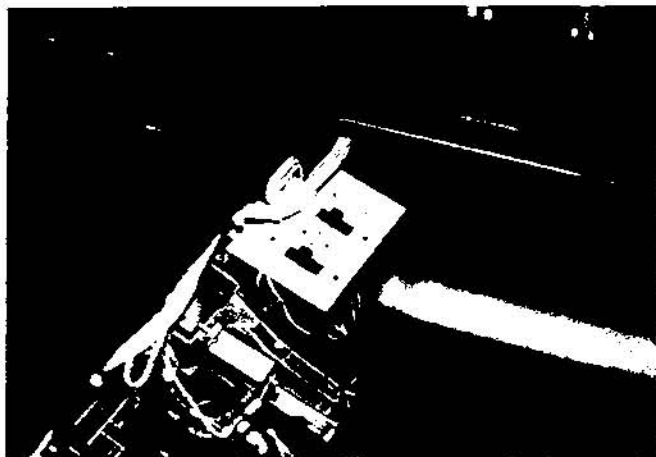

FIGURE 1-6 DOOR SWITCHES

1.8.2 ENTERING INTO THE SELF TEST MODE

To enter the Self Test Mode, press the Advanced Sub Test Switch on the Coin Door or the Self Test Button found near the LED display. All the LED's should blink on and the Hardware Tests should start. The Diagnostics can be entered at the Location Programming Screen (Section 1.8.16) by pressing the Advance Test Switch on the Coin Door. If a continual test of the Video Board is desired, press the Self Test Button twice to start the Video Test in the Auto Test Mode. In this mode, the machine will continually run the Hardware Test until powered off. If the message "OPEN COIN DOOR TO TEST" appears the Coin Door must be opened or a jumper connected across J19, 1-2. This is because the CMOS RAM Test (Section 1.8.6) cannot be performed with the memory protected by the Coin Door Switch.

1.8.3 HARDWARE TESTS

These tests are performed in the following order:

VIDEO BOARD	DATA BOARD
ROM Checksum	ROM Checksum
Communications RAM	Local RAM
CMOS RAM	Communications RAM
Color RAM	Handshake Test
Screen RAM	

TABLE 1-2 HARDWARE TESTS

All LED Values are shown Left to Right, 0 if OFF, 1 is ON and X is dependent upon the test results.

1.8.4 VIDEO BOARD ROM CHECKSUM

The ROM Checksum calculates the Checksum of each Video ROM and compares it to the Checksum stored for that ROM. If it differs from the stored value, the machine will halt and the Value of the ROM with the bad Checksum will be shown on the LED'S.

LED VALUES: TEST IN PROGRESS 00 0001
FAILURE: 01 XXXX

LED VALUE	VIDEO	2716	2732
01 0000	A000-A7FF	N/A	U5
01 0001	A800-AFFF	N/A	U5
01 0010	B000-B7FF	N/A	U6
01 0011	B800-BFFF	N/A	U6
01 0100	C000-C7FF	U3	U7
01 0101	C800-CFFF	U4	U7
01 0110	D000-D7FF	U5	U8
01 0111	D800-DFFF	U6	U8
01 1000	E000-E7FF	U7	U9
01 1001	E800-EFFF	U8	U9
01 1010	F000-F7FF	U9	U10
01 1011	F800-FFFF	U10	U10

TABLE 1-3 VIDEO BOARD ROM CHECKSUM

If the Checksum ROM is bad, it will show U10 to be bad first. If this test fails, the ROM indicated on the LED display will need to be replaced. The E-PROM Memory in a given game may be implemented as banks either 2716 or 2732 E-PROMS. The E-PROM type for each bank is selected by the decoding jumper 26-00002-016 or 26-00002-032.

E-PROM BANK	LOCATION
VIDEO	U1
DATA	U22
SOUND	U29

TABLE 1-4 DECODING JUMPER LOCATION

1.8.5 COMMUNICATIONS RAM FROM VIDEO BOARD

The Communications RAM Test determines the stability of memory shared by the two processors by storing a predefined series of numbers throughout the RAM, then reading it back to insure that it was stored correctly.

LED VALUE 00 0010

A failure has been detected when the machine halts with the above display. Failure of Communications RAM during Video Board Tests may result from either defective RAM circuitry or failure of the Data Board. To isolate the failure, disconnect the Data Board at P6 and re-enter the Test. A failure means trouble in U3, or U4 or associated circuits. Passing the retest suggests Data Board problems.

1.8.6 VIDEO BOARD CMOS RAM

After saving values in another portion of memory, the CMOS RAM is tested in the same manner as the Communications RAM. If the CMOS RAM passes the test, all of the locations are restored to their previous values.

LED VALUE 00 0011

A failure of the CMOS RAM has been detected when the machine halts with the above LED value displayed. If this occurs U85 and U86 or associated decoding should be checked.

1.8.7 VIDEO BOARD COLOR RAM

This tests the system Color RAM by storing predefined sequences of numbers in the Color RAM, then reading them back while testing for accuracy.

LED VALUE 00 0100

A failure is indicated by the Processor halting with the above value displayed on the LED'S. This signifies the need to check U56, U57 and associated multiplexing and decoding.

The Screen RAM is tested by writing a pattern to each page on the screen. The results of these writes is then compared to the original pattern. Any discrepancy causes the machine to halt with the LED displaying the faulty RAM.

LED VALUES: TEST IN PROGRESS 00 0101
FAILURE 1X XXXX

LED VALUE	RAM	11 XXXX	RAM
10 0000	U33	11 0000	U66
10 0001	U32	11 0001	U65
10 0010	U31	11 0010	U64
10 0011	U30	11 0011	U63
10 0100	U29	11 0100	U62
10 0101	U28	11 0101	U61
10 0110	U27	11 0110	U60
10 0111	U26	11 0111	U59
10 1000	U17	11 1000	U48
10 1001	U16	11 1001	U47
10 1010	U15	11 1010	U46
10 1011	U14	11 1011	U45
10 1100	U13	11 1100	U44
10 1101	U12	11 1101	U43
10 1110	U11	11 1110	U42
10 1111	U10	11 1111	U41

TABLE 1-5 VIDEO RAM CHECKSUM

Upon failure of a Screen RAM, locate the problem RAM and replace it. Exchange the suspected RAM with a known good location to determine if the problem moves with the RAM, IC or whatever the problem is in the supporting circuitry. Further testing can be done with the Color Bar Test.

If this Diagnostic appears to halt without indicating a RAM failure (00 0101 on LED'S), a failure to begin the next test (Data Hardware) is indicated. The interconnection to the Data Processor must be in place and the Data Processor must be functional to continue.

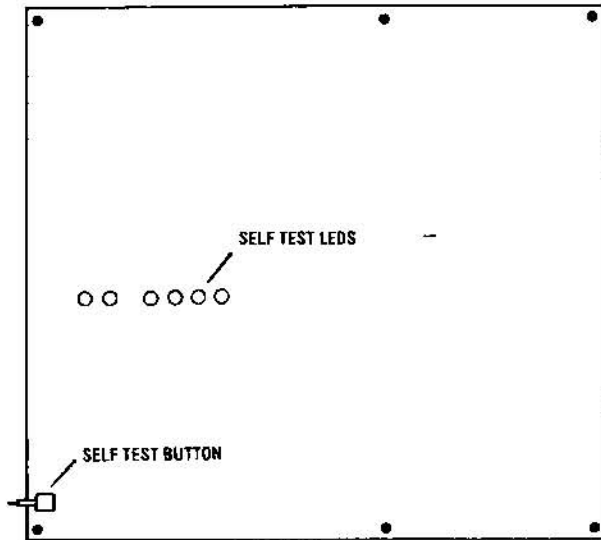

FIGURE 1-7 VIDEO BOARD (ON BACK SERVICE DOOR)

**1.8.9 DATA/SOUND BOARD SELF TESTS
DATA HARDWARE (ROM CHECKSUM)**

The ROM Checksum calculates the Checksum of each Data ROM and compares it to the Checksum stored for that ROM. If it differs from the stored value, the machine will halt and the value of the ROM with the bad Checksum will be shown on the LED'S.

LED VALUES: TEST IN PROGRESS 00 0110
FAILURE 01 XXXX

01 0000	A000	N/A	U14
01 0001	A800	N/A	U14
01 0010	B000	N/A	U15
01 0011	B800	N/A	U15
01 0100	C000	U12	U16
01 0101	C800	U13	U16
01 0110	D000	U14	U17
01 0111	D800	U15	U17
01 1000	E000	U16	U18
01 1001	E800	U17	U18
01 1010	F000	U18	U19
01 1011	F800	U19	U19

TABLE 1-6 DATA/SOUND BOARD ROM CHECKSUM

If this test fails in the field, the bad ROM will need to be replaced.

1.8.11 DATA/SOUND BOARD LOCAL MEMORY

The Data Processor uses a known sequence of numbers to test the bits in its local memory. If a bad bit is found the machine will halt with the following display.

LED VALUE: 00 0111

1.8.11 COMMUNICATIONS RAM ADDRESSING

The function of this test is to ensure that both the Data and the Video Processor address the Communications RAM in the same manner. The Data Processor requests the Video Processor to fill the RAM with a known pattern then, the Data Processor compares the results to the expected pattern. If it does not match one of the Processors is probably decoding the address incorrectly as the RAM itself was previously tested for stability by the Video Processor. The machine will halt with the following display.

LED VALUE: 00 1000

1.8.12 DATA/VIDEO HANDSHAKE

This test ensures that the Data Processor can send priority commands via interrupts to the Video Processor after the proper command acknowledgements are received. The machine will halt with the following display.

LED VALUE: 00 1001

1.8.13 SWITCH TEST

This Screen is used to determine all Switches are in working order before entering the switch dependent self-test screens. The Wiring Diagram supplied with each game will indicate the number associated with a particular switch. The switch number appears in green if the switch is closed and white if it is open.

The Advance Test Switch (Switch Number 9) is always RED in order to set it apart from the other switches on the screen. Switches 29, 30, 31 and 32 are not used and remain green. The user should check all other switches before pressing the Advance Test Switch, as this would move him to the next screen. In addition to the switches required, by the game, the User should be sure to test the Advance Sub Test, UP and DOWN Switches located in the Coin Door for proper closure as the switches are used to move about in the Self Test Screens. To advance to the next screen, activate the Advance Test Button on the Coin Door.

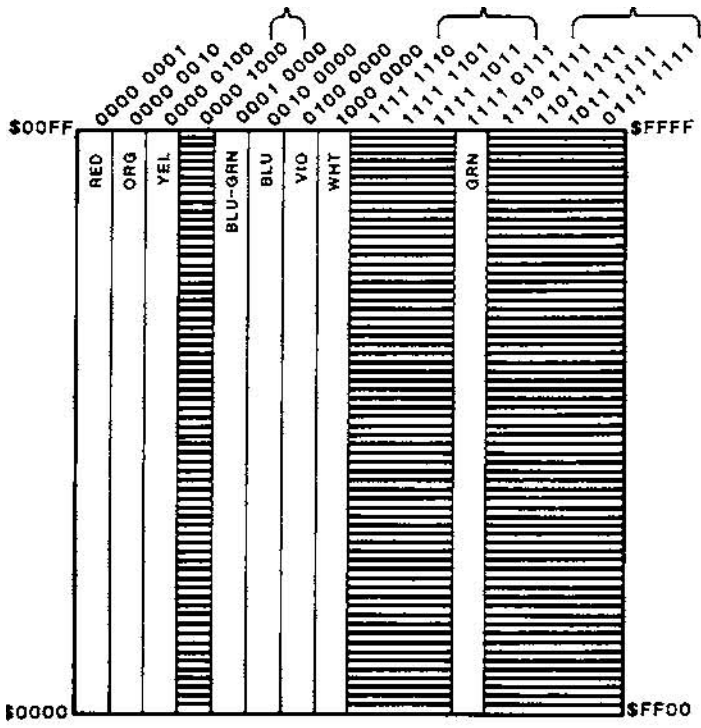

COLOR BAR DIAGNOSTIC
 BIT 03 STUCK LOW IN 1-BANK
 FIGURE 1-10 COLOR BAR DIAGNOSTIC BIT 03 LOW

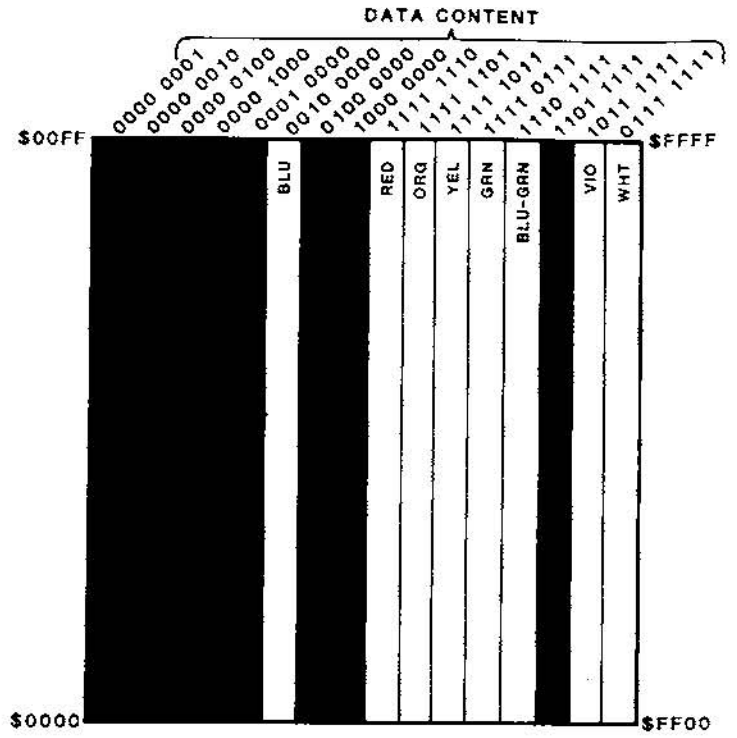

COLOR BAR DIAGNOSTIC
 BIT 5 STUCK HIGH ALL BANKS
 FIGURE 1-11 COLOR BAR DIAGNOSTIC BIT 5 HIGH

NOTES

are ruled out. This leaves latches U91, U96 and U105-109, direction select U81 and U104 and the CR side of the Color RAM MUX U55, U73 and U74. Stuck bits may be identified by observing abnormal bars. A bit stuck high will result in black bars (two bit high) on the left or top half of the screen except for the bar associated with the stuck bit will be black. The converse is true of a bit stuck low.

An error across the entire bar indicates an error in the shift registers, direction select, or color RAM MUX which affects every pixel. Lines of error running crosswise to the bars indicates an error in one bank of RAM of every eighth pixel. To move to the next screen, activate the Advance Test Button.

If self test fails, the Color Bars still may be useful. This screen may now be entered without going through on-board self test. Use "Advance Test" to enter the High Score Screen then "Down" to enter the Switch Test. Advance Test may then be used to access the Color Bars.

1.8.16 ALIGNMENT AND CONVERGENCE TEST

This screen is provided to align the color guns and correct the convergence on the screen. The screen is composed of a red and green rectangle and white grid.

Adjust the screen width and length so that the red rectangle is slightly within the boundaries of the tube. The adjustment is to be made on the center of the lines which make up the rectangle. The corners of the rectangle will extend beyond the shadow mask.

The green rectangle defines the normal playfield and so should be visible from the players view point.

A grid of which squares is provided to help detect and correct any convergence problems the tube may have. Adjust the monitor until the squares are of equal size throughout the screen.

To advance to the next screen, activate the Advance Test Button on the Coin Door.

1.8.17 LOCATION PROGRAMMING SCREEN (LANGUAGE SELECTION)

This screen allows the user to select the language in which the Location Programming and the game will operate. Four (4) languages are provided. Use the Advance Sub Test Button to move through the offered languages. When the desired language is green, depress the Advance Test Button, to advance to the next screen.

1.8.18 LOCATION PROGRAMMING

This screen allows the location to define the difficulty factor for the game. It also allows the location to set a maximum number of credits allowed in the machine prior to a game start up.

The user selects the line to be changed by using, the Advance Sub Test Button until the desired line is changed to green. The value associated with this line is then modified with the UP and DOWN Switch. If the machine is to be reset to the factory settings, use the Advance Sub Test Button until the reset line is lit in green, then press the UP Switch. The values will be reset and the user will be placed back on the first line for further adjustments. Advance test will move to the next screen at any time.

The maximum credits defines a limit for the machine, which when crossed will disable the coin slots. This allows the location to set a limit on the amount of games a player will get if there is a line of people waiting. This value ranges from 1 to 99. However, it should not be set so close to 99 that a single coin can overflow the credits issued (maximum 99). A Free Play Mode may be selected by setting maximum credits to 0. The credits per coin slot are set in the coin slot programming screen.

This screen shows the scores and initials of the players with the te highest scores. It is used as an audit for the game. To reset if values to the backup HSTD selected on the previous screen, pres the UP Switch. This will also set the initials to "TAC".

When the UP Button is activated it resets to default scores. To mov to the next screen, activate the Advance Test Button on the Coi Door.

1.8.20 AUDIT TOTALS

The screen provides the audit totals for the game. Once they ar recorded, they may be zeroed by pressing the UP Switch. The fol lowing audits are kept.

Total Credits	The total number of paid credits issued. This total is never zeroed, but it will wrap around to zero when its total reaches 1,000,000. The only time this total can be zeroed is by physically removing the battery or jumper W1, while the power is OFF.
Left Coins	The number of coins dropped into the left slot.
Center Coins	The number of coins dropped in the center slot.
Right Coins	The number of coins dropped into the right slot.
Paid Credits	The number of credits issued for coins.
Awarded Credits	The number of credits awarded by the game.
% Free Plays	Awarded Credits/Paid Credits + awarded credits. *100
Minutes Played	Number of minutes the game has been in play mode.
Minutes Awarded	Number of minutes the game has been in extended or awarded play.
% Free Time	Awarded minutes/minutes played *100.
Average Game (Sec)	Minutes played/paid credits + awarded credits *60.
High Scores	The number of times which a player score high enough to bump someone else from the score list.

TABLE 1-8 AUDIT TOTALS

The UP Switch is used to zero the audits. To advance to the nex screen, activate the Advance Test Button on the Coin Door.

1.8.21 COIN SLOT PROGRAMMING

This screen allows the user to either select a standard coinage setting for the game or program his own. If a standard setting is desired, use the UP and DOWN Switch to adjust the coinage setting while it is lit in green. The values for the variable will change as this number is altered. When the right selection is set, use the Advance Test to return to the game.

If a non-standard setting is desired, use Advance Sub Test Switch to move down to the variables so that they may be programmed individually. Once this switch is pressed, the setting number is set to zero to show that the location has supplied their own settings. As the lower variables are unchanged, the user may minimize his effort by first selecting a setting close to the one he desires. Once in programming mode, the Advance Sub Test Switch is used to move among the variables. It will also take you back to the standard settings, if you press it by mistake. The UP and DOWN Switches are used to increment or decrement the values. Advance Test Switch will return to the game when pressed.

The coin multiplier tells how many coin units are issued for each coin through a particular slot. Coin units for credit show the number of units necessary before a bonus credit is issued.

Minimum coin is an optional value which will keep the credits from accumulating until the specified minimum amount of coin units is reached. It is not used in any of the standard settings.

1.8.22 CMOS MEMORY FAILURE

If the message "Memory Failure - Service Required" appears on the screen, the CMOS RAM which stores all of the location programming has failed. All the values stored in the RAM are set back to factory defaults. This condition probably indicates a battery failure or a failure of U85 or U86. Refer to Section 2 on Maintenance or 2.8 CMOS RAM.

STANDARD COIN SETTINGS

TABLE 1-9

		Standard Setting	Left coin slot multiplier	Center coin slot multiplier	Right coin slot multiplier	Coin units for credit	Coin units for bonus	Minimum coin units
COIN DOOR MECHANISMS	CREDIT/MONEY							
STANDARD	1/.25, 4/*1	01	01	04	01	01	00	00
	1/.50, 3/*1, 6/*2	02	01	04	01	02	04	00
	1/.50	03	01	04	01	02	00	00
1 DM, 5 DM	1/10M, 6/50M	04	06	00	01	01	00	00
1 FRANC, 5 FRANC	1/2F, 3/5F ONLY	05	01	16	06	02	00	00
25 CENTS, 1 GUILDER	1/25, 4/1G	06	01	00	04	01	00	00
5 FRANCS, 10 FRANCS	1/5F, 2/10F	07	01	00	02	01	00	00
	1/10F	08	01	00	02	02	00	00
1 FRANC, 2 FRANC	2/1F, 5/2F	09	00	04	01	04	00	00
1 UNIT, 5 UNITS	1/2, 3/5	10	01	00	06	02	00	00
TWIN COIN	1/1 COIN	01	01	04	01	01	00	00
	1/2 COINS	03	01	04	01	02	00	00

CUSTOM COIN SETTINGS

TABLE 1-10

		Standard Setting	Left coin slot multiplier	Center coin slot multiplier	Right coin slot multiplier	Coin units for credit	Coin units for bonus	Minimum coin units
COIN DOOR MECHANISMS	CREDIT/MONEY							
STANDARD	1/.25, 5/*1	00	01	04	01	01	04	00
	2/.50, 5/*1	00	01	04	01	01	04	02
	2/.50, 4/*1	00	01	04	01	01	00	02
	1/.50, 3/*1, 4/*1.25	00	03	12	03	04	15	00
	1/.50, 3/*1, 7/*2	00	12	48	12	14	96	24
25 CENTS, 1 GUILDER	1/.25, 5/1G	00	01	00	04	01	04	00
100 LIRE, 200 LIRE	1/200 LIRE	00	01	00	02	02	00	00
TWIN COIN	1/3 COIN, 2/5	00	02	00	02	05	00	00
1 UNIT, 5 UNITS	1/1, 5/5	00	01	00	05	01	00	00
	1/3, 2/5	00	02	00	10	05	00	00

NOTES

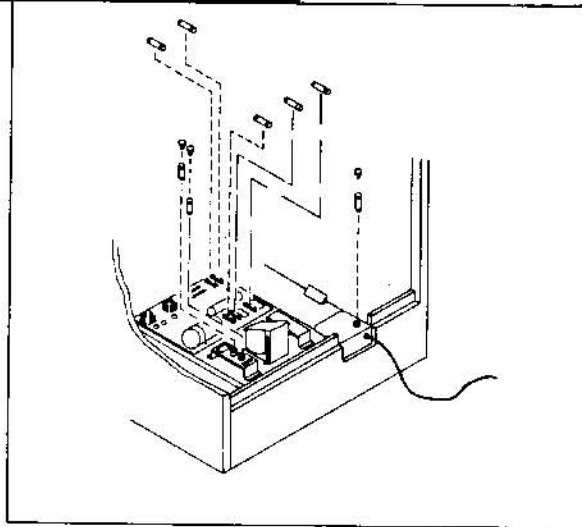
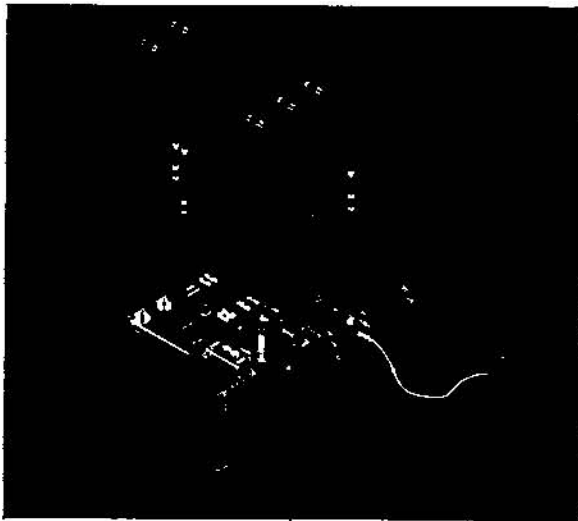

Maintenance

ALL GAMES REQUIRE A CERTAIN AMOUNT OF MAINTENANCE TO KEEP THEM IN GOOD WORKING ORDER. A PERIODIC CHECK OF THE MECHANICAL CONTROLS WOULD BE BENEFICIAL TO THE SUCCESS OF YOUR GAME.

2

2.1 CLEANING

The exterior of the game, all metal parts and all plastic parts can be cleaned with a non-abrasive cleanser. Caution should be used when cleaning the glass, a dry cloth can cause scratches and result in a foggy appearance.

2.2 COIN DOOR

The Coin Door used in the "KRAM"™ game needs little or no maintenance. See Figure 2-1. If desired a special coin mechanism cleanser, that leaves no residue, can be obtained from your distributor. Refer to the manufacturers documentation if additional information is needed.

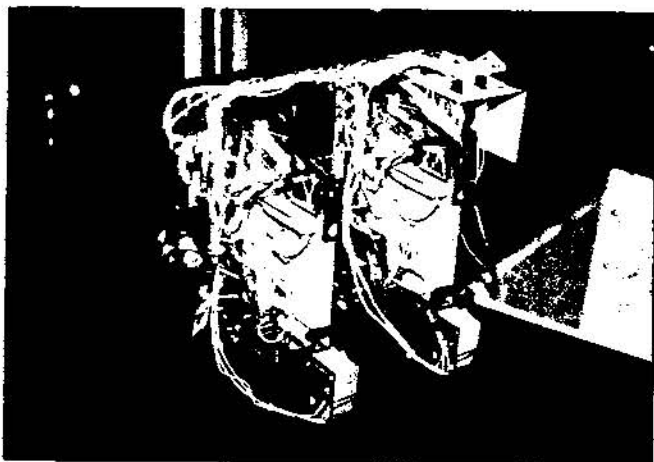

FIGURE 2-1 COIN DOOR

2.3 FUSE REPLACEMENT

This game contains 8 fuses. Seven of these fuses can be found on the Power Supply Assembly, five (5) are on the PCB and two (2) are on the Power Supply Bracket. One (1) is located at the bracket where the AC line cord comes into the cabinet. See Figure 2-2 for locations of these fuses.

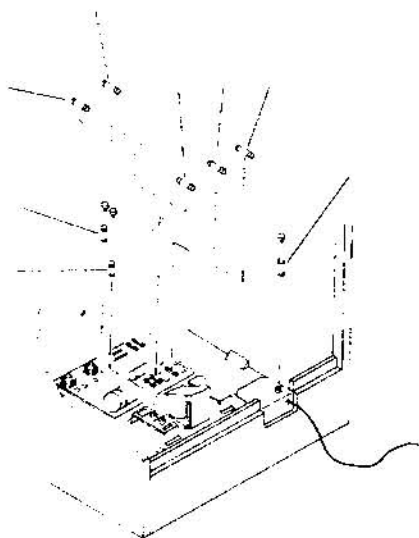

FIGURE 2-2 FUSE REPLACEMENT

If you need to remove the video monitor, follow the instructions listed below:

CAUTION

It is recommended the game be left disconnected for at least one hour before removing the Video Monitor. This will probably discharge the Video Tube but EXTREME CAUTION is still necessary.

- Disconnect power from the line voltage
- Disconnect the Monitor cable connector.
- Remove the wire cable clamp.
- Take out the two side bolts, one on each side of the cabinet.
- Remove the four mounting bolts and disconnect the green ground wire.
- Slide the Monitor out by pulling the Monitor toward you.

CAUTION

Use EXTREME CAUTION and do not touch electrical parts of the Monitor Yoke area with your hands or with any metal object in your hands! High Voltages may exist in any Monitor, even with power disconnected.

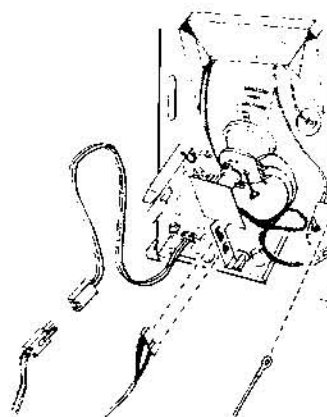
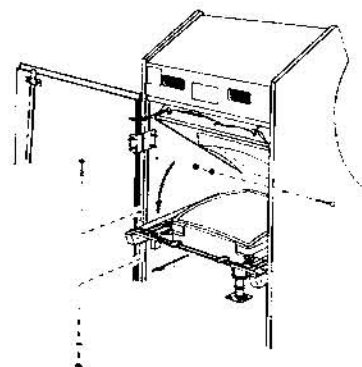

FIGURE 2-3 MONITOR REMOVAL

2.5 COVER GLASS REMOVAL

To remove the Cover Glass follow the instructions listed below:

1. Remove the Control Panel.
2. Loosen three (3) screws on the Cover Glass, front bracket.
3. Open the Service Door and remove the (Rear) Cover Glass Bracket.
4. Slide the glass out through the Service Door.

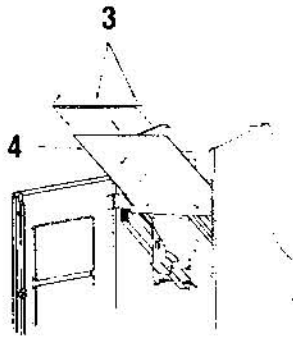
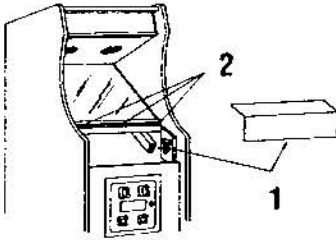
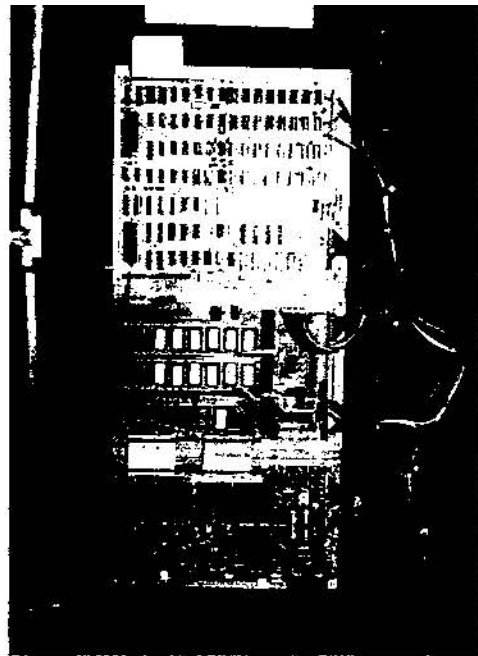

FIGURE 2-4 COVER GLASS REMOVAL

2.6 PRINTED CIRCUIT BOARD REPLACEMENT

You may wish to remove the "KRAM"™ printed circuit board, Video Processor (08-00001-002), Data/Sound Board (08-00002-002), or ROM I/O Board (08-00030-001) for servicing. Refer to Figure 2-5. The "KRAM"™ Printed Circuit Boards (PCB) are located on the inside of the rear service door for easy access.

1. Open the Rear Service Door, the power will automatically be removed by the Interlock Switch located on the inside of the door frame.
2. Disconnect the connectors from the board or boards you wish to remove.
3. Disconnect the ribbon cable, connecting the boards by spreading eject latches on the connector.
4. Remove the screws for the board you wish to remove.



2.7 POWER SUPPLY

The Power Supply produces all the necessary game voltage requirements. Refer to Figure 2-6 while reading the following circuit description.

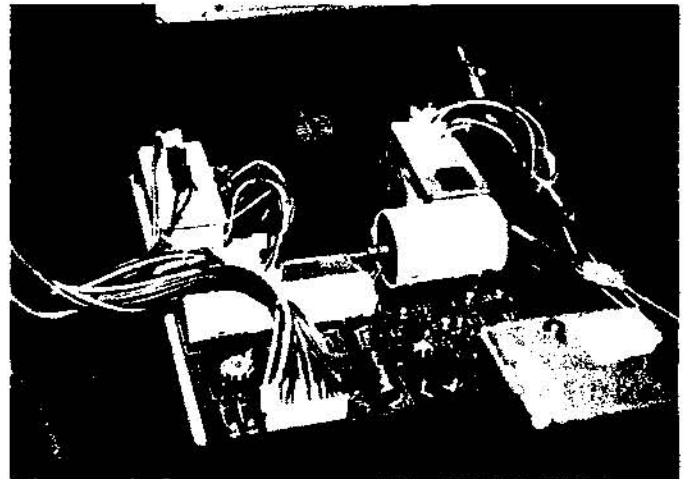

FIGURE 2-6 POWER SUPPLY

2.7.1 AC INPUT

The AC Input Voltage is applied to the main Power Supply via the AC Line Cords, Line Filters, Line Fuse, Power Switch and Interlock Switch. Different Line Cords are used for 120V and for 240V. The Line Fuse is located on the Line Cord Assembly near the Strain Relief. A Voltage Programming Block is located on the primary side of the Transformer to compensate for high/low voltage conditions. The following line voltages may be made by inserting the appropriate Programming Plug.

Line Voltage		Line Fuse
100 VAC ± 10%	50/60Hz	3 AMP
120 VAC ± 10%	50/60Hz	3 AMP
200 VAC ± 10%	50/60Hz	1.5 AMP
220 VAC ± 10%	50/60Hz	1.5 AMP
240 VAC ± 10%	50/60Hz	1.5 AMP

TABLE 2-1 LINE VOLTAGE

CAUTION

For continuous protection against fire hazard, replace only with a fuse of the same type having the same electrical rating.

There are five secondary sources. Three go to the Regulator PCB providing +5VDC, +12VDC, -12VDC and -5VDC. The other two are fused 6.3VAC used for the incandescent lighting and fused 120VAC used for the monitor, and in certain models for a fluorescent lamp and fan. These secondary fuses are located on the bracket adjacent to the Power Transformer.

Circuit	Secondary Fuse
120VAC	2.0AMP SLO-BLO
6.3VAC	2.5AMP

TABLE 2-2 SECONDARY FUSES

2.7.2 -5VDC AND -12VDC REGULATORS

The AC Input for the negative voltages comes into the Regulator PCB on J1-5 and J1-6 from the Transformer. Fuse F3 protects against short circuits. The AC Voltage is then full wave rectified by BR3 and filtered by C16. The raw DC is then applied to Reg 1, a three terminal -12V Regulator. The output of this Regulator is the -12VDC output for the system and is also the input voltage for Reg 2, a -5V Regulator. The output of this Regulator is the -5VDC for the system.

Capacitors C17, C18, C19 are to improve the transient response and stability of the minus voltage regulator. Diodes D8 and D9 provide protection against C18 and C19 being shorted through the Regulator.

Resistors R34 and R35 provide current limiting for LED'S 3 and 4 which will light when there is voltage present at the regulation outputs.

2.7.3 +5VDC REGULATOR

The AC Input for the +5VDC Regulator circuit comes in on J1-4 and J1-2, via F1 into BR1 full wave rectifies the AC Input. This raw DC is applied to the collectors of (2) series pass transistors, mounted on the Heat Sink Assembly. The regulation is done by U3, which is a voltage regulator whose output controls the gain of Q5, which in turn controls the gain of the series pass transistors. The emitter of the series pass transistor return to the Regulators PCB and through R11 and R12, which serve to force current sharing between the series pass devices. The voltage at the output of R11 and R12 are the +5VDC for the system. R11 and R12 are voltage set and current foldback adjustments respectively. These are factory adjusted to 5V ± .25V at 7AMPS.

Q8, D3 and R20 comprises a SCR-Type Crowbar Circuit which will trigger when the DC output voltages rise above 5.8V. Once the SCR fires, the Power Supply has to be turned off to reset the device. R19 is a current limiter for the voltage indicator LED 1. R16 is used to set up the output voltage of the Regulator. C8, D2, R13 and Q4 delay the start up of the 5V Regulator to allow the -5VDC Regulator to stabilize first.

2.7.4 +12VDC REGULATOR

This circuit is essentially the same as the 5V Regulator described above. The AC current comes in on J1-3 and J1-4, via fuse F2 into BR2. The AC is rectified by BR2 and filtered by C9. The raw DC is fed into a single series pass transistor on the Heat Sink Assembly and also powers the +12V and +5V Regulator. R28 and R25 are voltage set and current foldback and factory adjusted to 12 Volts ± Volts ± .25V at 4AMPS. D7, Q9 and R31 are SCR Crowbar Circuits which trigger at 13VDC output which causes supply to go into current foldback. There is an RC delay as in the 5V circuit to delay the +12V rise time.

The reset circuit will output a 2sec active low MRST pulse at J3-14 J4-14 when the power is first turned ON and whenever power fails for more than 35ms.

The reset circuitry is comprised of a Dual Timer (556) and a fullwave type optical coupler across an AC secondary. The output of U1 is the input to one half of the 556 which is configured as a missing pulse detector. C1 and R3 determine the time before the output goes active. This is set for about 35ms. When two or more cycles are missing, the output of the first timer triggers the second timer which drives the MRST low for about 2 seconds. The timer constant for the second timer is set for R4 and C6.

Power on reset is generated by C4, and R39 and D12 on the trigger input of the second timer. Q3 inverts the signal out of the 556 so it is active low. R7 insures MRST is low while the power is rising.

2.7.6 POWER SUPPLY ADJUSTMENTS

VOLTAGE Adjust voltages on +5V and +12V for +5.00V to +5.05V and -12.00V to +12.05V.

CURRENT LIMITER Adjust control (5I and 12I) counterclockwise until voltage just changes, then turn control clockwise until voltage goes back to original value with pointer, mark position of arrow on potentiometer then turn control until beginning of 1st notch is aligned with the pointer. On the controls with the Blue Disk turn approximately 30°.

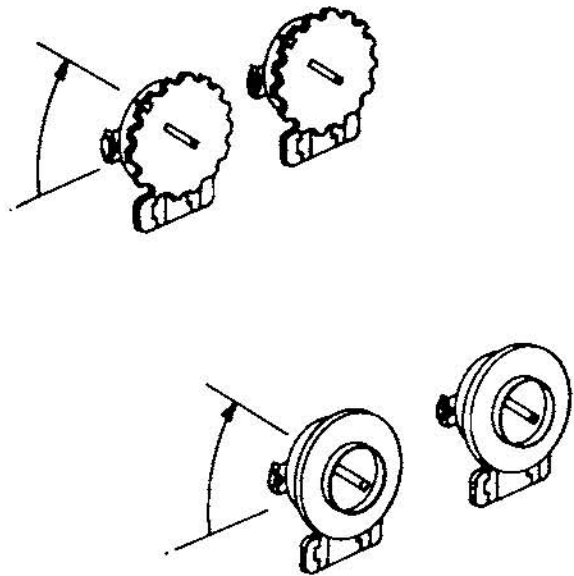

FIGURE 2-7 CURRENT LIMIT ADJUSTMENT

NOTE: If Voltage adjustment will not bring voltage up, set current limit adjustment to 1/2 value.

2.8 CMOS RAM

If when powering the game up, it will not coin up because the battery is low. The following Procedure should be followed.

Open the Back Door of the game, pull W1 out on the Video Board (Blue Jumper). Wait 2 minutes, power back on and insert W1 back in. Open the Coin Door and pull out bottom interlock Switch. If the Language Select Frame does not come on the CRT, power down remove W1 again. Short pins 18 and 9 on U85, power back on and insert W1 back in. Leave the game on for 12 hours. If this Procedure does not work when you turn the game back on the battery may need to be replaced.

2.9 TEST POINTS

The following is a list of Test Points to be used when troubleshooting.

DATA/SOUND BOARD

DTP1	E	(Master Clock)
DTP2	Q	(Master Clock)
DTP3	LIC	Last Instruction Complete
DTP4	SA 15	(Address Line)
DTP5	DA 15	(Address Line)
DTP6	Voice Clock	
DTP7	SBSC	(Sound Processor Data Enable)
DTP8	DBSC	(Data Processor Data Enable)
DTP10	+5V	
DTP11	Ground	

TABLE 2-3 DATA/SOUND BOARD TEST POINTS

VIDEO BOARD

VTP1	Invert	
VTP2	10MHZ	
VTP3	VQ	(Clock Video Processor)
VTP4	VE	(Clock Video Processor)
VTP5	EXTAL	(External Clock)
VTP6	LIC	Last Instruction Complete
VTP7	VBSC	(Video Data Enable)
VTP8	VA 15	(Address Line)

TABLE 2-4 VIDEO BOARD TEST POINTS

If you ground any Data Enable Test Point (DTP7, DTP8, VTP7) the related processor will receive NO-OP and the address line will act like a 16 Bit Counter.

NOTES

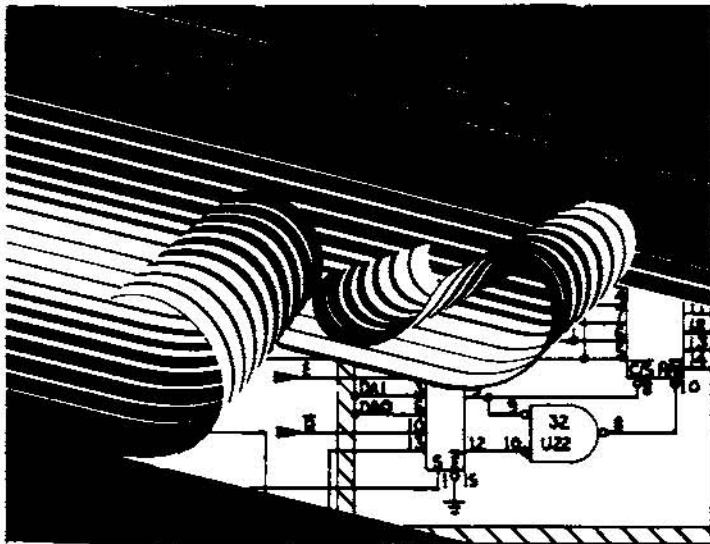

Theory Of Operation

3

THIS SECTION PROVIDES A TECHNICAL DESCRIPTION OF THE "KRAM"™ GAME. THE GAME ELECTRONICALLY CONSISTS OF PRINTED CIRCUIT BOARDS, TV MONITOR, POWER SUPPLY, AND SPEAKERS WHICH ARE DESCRIBED IN DETAIL IN THE FOLLOWING TEXT.

3. THEORY OF OPERATION

3.1 GENERAL

The TAITO AMERICA CORPORATION'S arcade video system game is an advanced multiprocessor based circuit utilizing the Motorola 6809E microprocessor.

The system is organized in three logical blocks:

- A. The Data Processor, which supervises the operation of the entire system.
- B. The Video Processor, which performs all screen based functions, such as playfield image motion, line drawing, etc.
- C. The Sound Processor, which generates sounds under the direct control of the Data Processor.

In order to facilitate easy inter-system communications, the Data and the Video Microprocessor run synchronously using clock and timing signals developed on the Video Board. For this reason, discussion will begin by examining the Video Board.

3.3 VIDEO BOARD

3.2.1 SYSTEM CLOCK

The fundamental system clock is developed by the 20MHZ crystal, inverters U24 and U39, and components. The 20MHZ signal is divided by the high speed flip flop U38 to obtain a 10MHZ main clock with a precise 50 percent duty cycle. This 10MHZ signal generates all other fundamental timing signals for the video system including the Data Processor. IC23 divides the 10MHZ signal to obtain 5MHZ, 2.5MHZ and CCLK, and their respective inversions.

IC's U9, U37, and U38 combine these signals, presenting them to U25, which synchronizes the output signal to the system 10MHZ clock. This circuit produces waveforms whose active edges are synchronized to 15ns worst case, 2ns average.

The characteristics of the clock circuit may be noted by reference to the Timing Diagram, Figure 3-1.

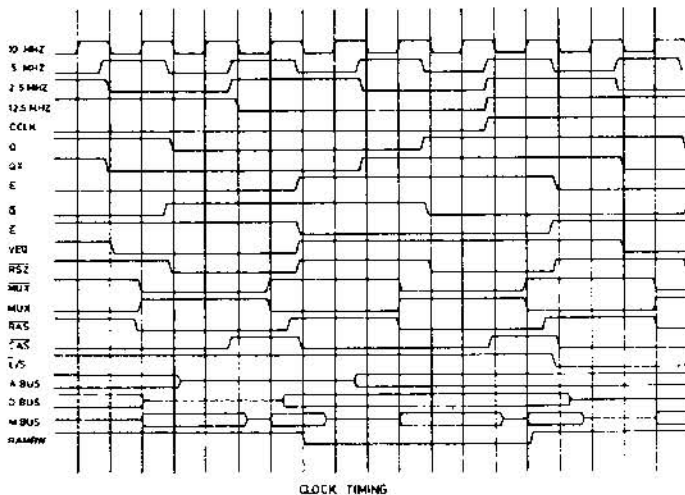

FIGURE 3-1 CLOCK TIMING

3.2.2 SCREEN RAM

The Video Processor controls a Screen RAM of 256 X 256 pixels with 8 bits per pixel. In order to access of this information, the screen is divided into two pages, top and bottom, chosen under software control. These pages are both addressed at 0000 - 7FFF with address 0 corresponding to the lower left corner of the screen (horizontal scan). All CRT accesses to this RAM are transparent to the processor and the RAM may be read or written any time. The timing of the Screen RAM and the eventual scan is controlled by a 6845/6545/46505 CRT Controller Chip. It's address outputs are gated by U19, U20, U50, or U51 for inversion when used in a Cocktail table mode. The scan addresses are multiplexed with the address present on the microprocessor address bus by U35, U52, U53 and U54 for standard RAS-CAS accessing. The desired bank of memory is addressed by U87, a one of four decoder.

Data written into the Screen RAM comes directly from the system data bus, buffered by 33 Ohm resistors. If a processor read is taking place, the data is placed on the data bus by U77, U78, U79 and U80. First byte, screen reads are latched by 374's U91, U92, U93 and U94. A second byte screen read is then performed and this data, together with the data from the first screen read latched by the 374's is loaded into the eight (8) 74LS299 shift registers. These registers may be shifted in either direction for cocktail table implementation. The byte stream then proceeds to the Color RAM.

	ADDRESS	VIDEO BOARD MEMORY MAP
A.	\$8000	Dual Port RAM
B.	\$8400	CMOS Batter Backup Memory
C.	\$8800	LED Output and Color RAM Page Select
D.	\$8C00	Data FIRQ Activation Address
	\$8C01	Video FIRQ Deactivation Address
E.	\$9000	Color RAM
F.	\$9402	Address Latch Hi-Byte
	\$9403	Address Latch Lo-Byte
	\$9400	Address Latch Indexed Screen Location
G.	\$9800	Scan Line Readback Location
H.	\$9C00	CRT Controller Base Address

TABLE 3-1 VIDEO BOARD MEMORY MAP
(\$ = HEXADECIMAL)

3.2.3 DUAL PORT RAM

This RAM may be accessed in its entirety by either processor. This is arbitrated as follows:

1. The Data Processor runs in quadrature with (one quarter clock cycle ahead of) the Video Processor. In other words, E is inverted for use as DQ, and Q becomes DE. Refer to Timing Diagram, Figure 3-2.
2. The Data Processor, by nature of this timing, accesses the Dual Port RAM 1/4 cycle before the Video Processor. At this point the Video Processor is guaranteed to not be accessing the RAM. The Data Processor access is flagged by U36, which causes a cycle to be stolen from the Video Processor's main clock, VQ and VE.
3. The Video Processor is unable to access the Dual Port RAM unless the Data Processor is not accessing it as it will not be receiving clocks during that time. The cycle steal is accomplished by the generation of signal DPMUX by U36. This signal directly steals the cycle, and also folds over multiplexers U5, U6 and U21, switching the address lines, R/W and gating signals. U1 and U2 gate the data to or from the desired Processor. U22 insures that no spurious writes are generated during foldover.

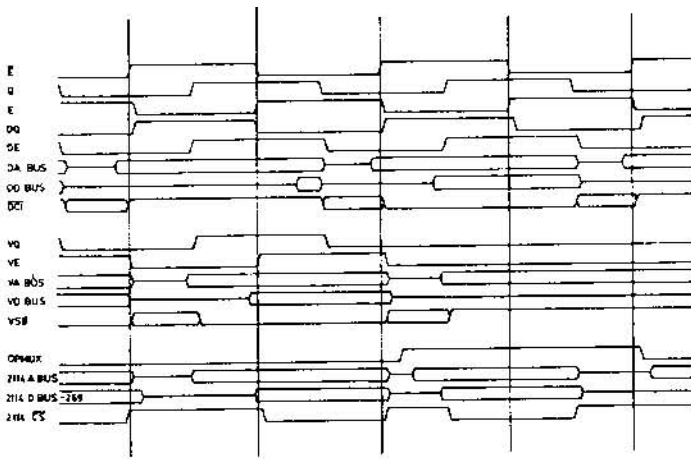

FIGURE 3-2 PORT RAM TIMING

may be directly addressed by reference to locations \$0000 - \$7FFF. U36, U70 and U71 latch the address. U36 is used in conjunction with U70 as U70 and U71 are tri-stated when inactive. The screen address deposited on the LA Bus by U84 and U98 for Processor Bus accesses, and by U70 and U71 for latched address. Decoding is performed by U87 and U88.

3.2.8 SCAN LINE READBACK

When read, this location is the number of the scan line currently being drawn by the beam. U34 latches the last row address drawn and U101 prevents erratic updating at the end of a horizontal line. There are 256 valid scan lines 00 - FF.

3.2.9 CRT CONTROLLER

The 6845/6545/46505 is a software programmable sync and scan generator. It has two ports based at \$9C00 and \$9C01. It is recommended that the reader consult Motorola, Hitachi, Rockwell, or Synertek supplied documentation.

Register initialization are as follows:

Register	Description	Initialization (decimal)
R0	Horizontal total-1	40
R1	Horizontal displayed	32
R2	Horizontal sync position	35
R3	Sync pulse width	03
R4	Vertical total-1	31
R5	Vertical hold adjust	17
R6	Vertical displayed	32
R7	Vertical sync position	32
R9	Scan lines per row-1	07

TABLE 3-2 REGISTER INITIALIZATION

3.2.4 CMDS RAM

The CMOS RAM is implemented for use as both a battery back-up storage area and a work area for the Video Processor. The gating U100, U101, U102 and U103 insure that writes to the block of RAM form \$8700 - 87FF cannot be performed unless the Coin Door is open (J19-2 grounded). The 3.6V NiCAD battery is trickle charged by Q8, R64 and R65 when the system is powered. When turned off, supply current for U85, U86 and U100 is provided by this battery. U100 is included to solidly gate the MRST signal and prevent invalid operations during power Up and Down.

LED and Color RAM Page Latch, U72, is addressed at address \$8800. The upper six bits drive LED'S on the circuit board for diagnostics which cannot be done through the screen. The lower 2 bits select the Color RAM page and will be discussed later.

3.2.5 BI DIRECTIONAL FIRQ CAPABILITY

To provide for immediate inter-system communication on demand a Bi-Directional FIRQ capability has been provided. Any access of address \$8C00 by the Video Processor will generate a FIRQ to the Data Processor will remove a FIRQ generated by the Data Processor to the Video Processor. This is accomplished by U7, U8 and U9.

3.2.6 COLOR RAM

The Color RAM is used as a translation matrix so that a number of different pixel values may access a given color, or to change the color of a given area of the screen without rewriting the Screen RAM. The serial bit stream, eight bits wide comes from the shift registers of the Screen RAM to be presented to multiplexers U55, U73 and U74. These select between the Video Processor bus and the serial bit stream. As processor access times are considerably greater than the basic bit time (200ns), it is necessary to access through U75, and serial output is latched by U76. This Data Stream is converted to a color pallet of 64 colors and four intensities. When the serial bit is selected for access, the two high order bits are provided by the LED output latch. This allows the Programmer to select between four pages of RAM rapidly.

3.2.7 ADDRESS LATCH CIRCUITRY

Two methods of Screen Memory Address are provided:

1. A 16 bit address may be written into latch U70 and U71 addressed at \$9402 and \$9403. The addressed location may be accessed by reference to location \$9400.

3.3 DATA/SOUND BOARD

The Data Processor runs synchronously to the Video Processor, as was described in this Section (Dual Port Memory). All basic timing signals originate on the Video Processor Board and are bused onto the Data Processor Board. This Sound Processor and Amplifier circuitry also resides on this board.

3.3.1 MEMORY MAP

The following devices are available for access to the Data Processor.

A.	\$8000	Dual Port Memory
B.	\$8400	Local Memory
C.	\$8800	ACIA Base Address
D.	\$8C00	Video FIRQ Activation Address
	\$8C01	Data FIRQ Deactivation Address
E.	\$9000	Sound PIA
F.	\$9400	Game PIA 1
	\$9900	Game PIA 2
	\$9C00	Game PIA 3

TABLE 3-3 DATA/SOUND MEMORY MAP
(\$ = HEXADECIMAL)

3.3.2 DUAL PORT MEMORY

See discussion of Dual Port Memory under Video Processor Heading (Section 3.2).

3.3.3 LOCAL MEMORY

This is a 1K block of memory. U15 and U16, provided for scratch and work area for the Data Processor.

3.3.4 ACIA

A Motorola 6850 ACIA has been provided for diagnostic and other communications. Timing is generated by crystal oscillator Y1-U23 and prescaled by U27 and U26. SW1 may be configured to allow one of eight baud rates (2 speeds may be software selected in the ACIA). Correct RS-232 levels are provided by U25 and U21.

3.3.5 BI-DIRECTIONAL FIRQ CAPABILITY

Any access of \$8C00 will generate a FIRQ to the Video Processor. Any access of \$8C01 will remove FIRQ generated by the Video Processor to the Data Processor. This is accomplished by U7, U8 and U9 which resides on the Video Board.

3.3.6 SOUNB PIA

Both Ports of PIA U20 have been dedicated to the control of the Sound Processor. Port A is used to select a sound number, which is initiated by strobing the U20 (CA2) - U8 (CA1) interrupt. Port B is used to control the amplitude of the generated sound to the Stereo Amplifiers. The output side B go to U24 and U28, which vary the ratio of the voltage divider across the noninverting inputs of U29 and U30. This allows balance control of the sound to coincide with real time events occurring on the screen.

3.3.7 GAME PIA'S

Three 6820's are provided for interfacing with Play Controls and Coin Door Switches. These are located on the Game Board and are accessed through a Jumper Cable J16 and J15 respectively.

3.3.8 SOUND PROCESSOR

A motorola 6802 resides on the Data Board for generation. This processor runs at 3.68MHz and accesses only two devices. PIA'S U7 and U8. U8 as mentioned previously, interface to the Data Processor. It is also the digital to analog output of the Sound Processor. Data from Port B is presented to U13. The current based output is converted to a voltage output by Q1, and controlled in amplitude by a potentiometer placed across J8. Speech circuitry is mixed with sound by R9, and the sum is sent to the Amplifiers. U7 controls the speech synthesis chip U19. The speech signal is shaped and filtered by the multipole bandpass filter U18.

3.4 ROM/I/O/BOARD

This board contains the Program ROM for both the Data, Video and Sound Processors, along with the PIA'S needed to interface control coils, lamps, etc.

3.4.1 GAME PIA'S

Three Game PIA'S are located on the board \$9400, \$9900, \$9C00. These devices, U11, U20 and U30 respectively, interface through noise control circuits A or B filters for those lines dedicated to inputs. Eleven (11) High Current Drivers have been provided utilizing circuit C. Each of these is capable of switching a 1.5 AMP/24Volt load to ground.

3.4.2 ROM'S

Eight ROM locations are provided for the Data Processor, U12 - U19. These are selected by U21. Eight ROM'S U3 - U10 selected by U2 are dedicated to the Video Processor. Sounds are supported by ROM'S U25, U26, U27, with select U28.

ROM Bank U3 - U10 may consist of either 2716 or 2732 type EPROMS as determined by a jumper plug inserted in U1. It is assumed that all such EPROMS in the bank are of the same type. Likewise, ROM Bank U12 - U19 is determined by jumper plug at U22 ROM Bank jumpering for 2716's is as follows: Pin 1-14, 2-13, 3-12, 4-11 and 5-10. The highest Address EPROM is U10, U19 or U27 in each bank with addresses of adjacent sockets progressing downward in \$800 byte blocks.

Jumpering for 2732's is as follows: Pin 2-14, 3-13, 4-12, 5-11 and 6-10. The highest Address EPROMS is U10, U19 or U27 in each bank with addresses or adjacent sockets progressing downward in \$1000 byte blocks.

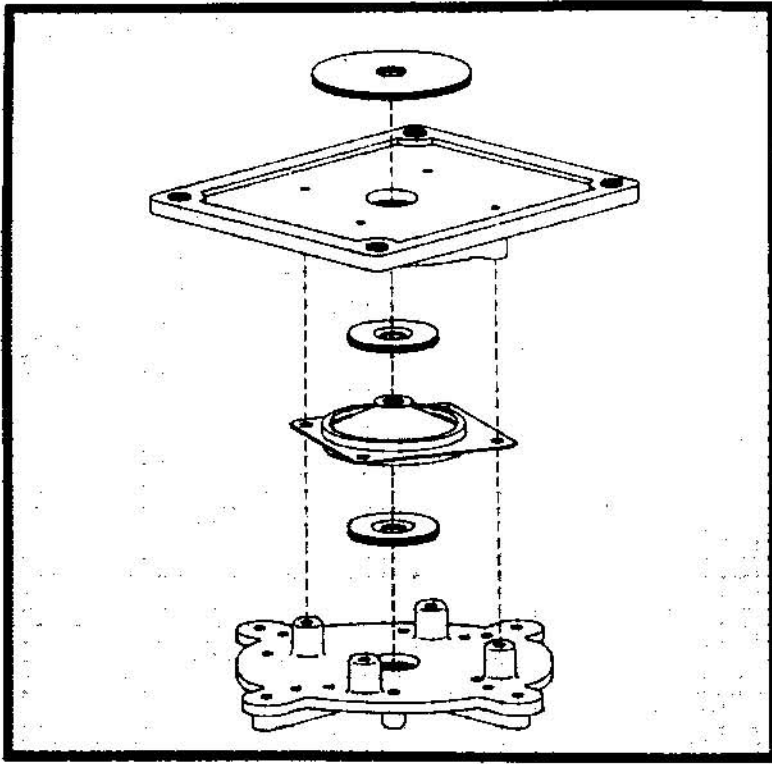

Illustration & Parts Lists

4

INDEPENDENT PANEL

FIGURE 1

ITEM	TAITO PART NO.	DESCRIPTION
1	27-00006-001	Lamp #47
2	26B00009-001	Bayonet Base Socket
3	61D00112-001	Marquee Lighting Plate

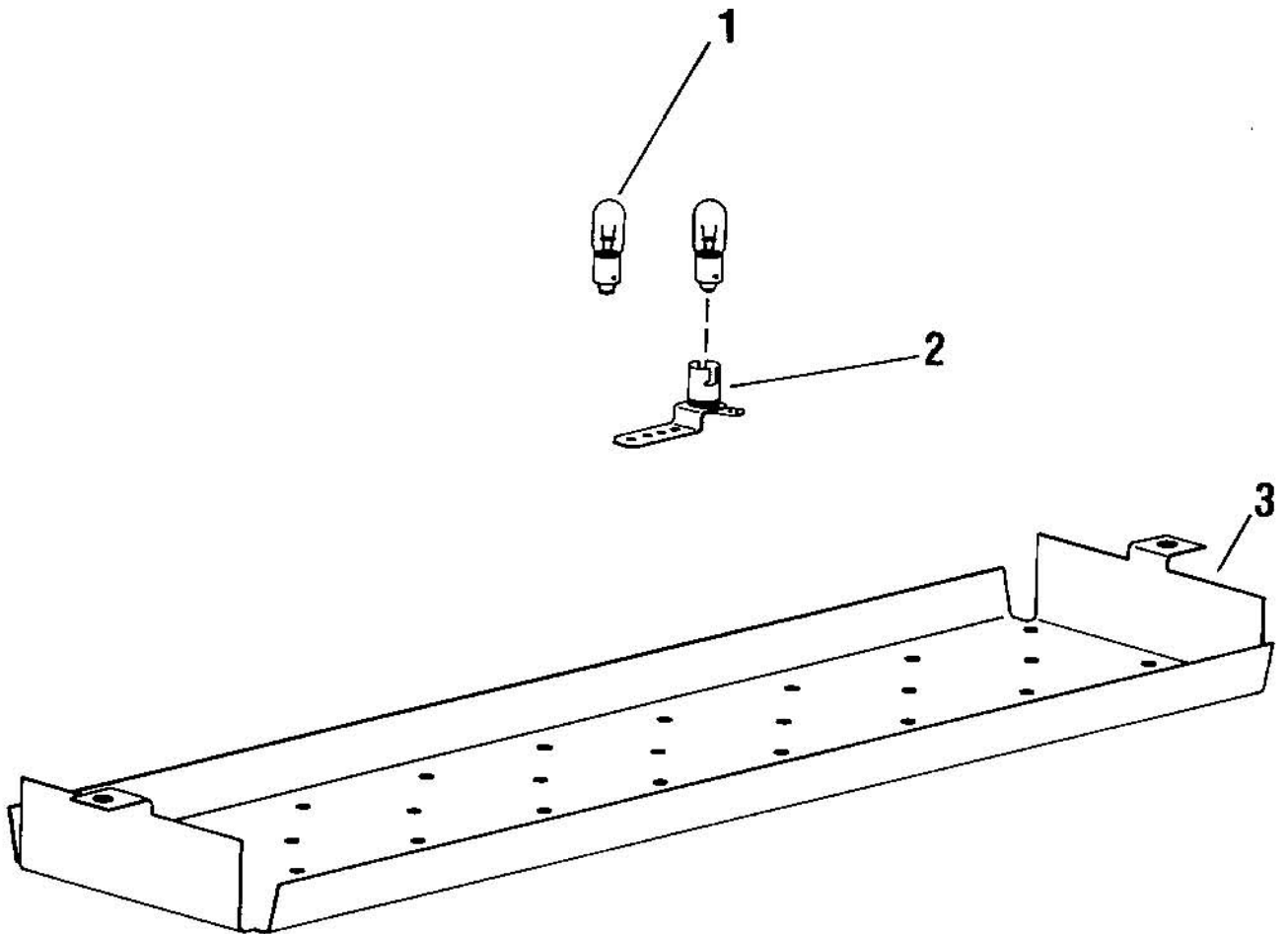

0-WAY JOYSTICK

FIGURE 2

ITEM	TAITO PART NO.	DESCRIPTION
1	63B00031-001	Ball & Shaft
2	63A00033-001	Mask
3	63C00027-001	Mounting Plate
4	62C00002-001	Shock Mount Pad
5	63C00028-001	Switch Plate
6	63A00030-001	Actuator
7	61A00078-001	"L" Bracket
8	63A00026-001	Switch Spacer
9	29B00018-001	Leaf Switch
10	63A00029-001	Spacer

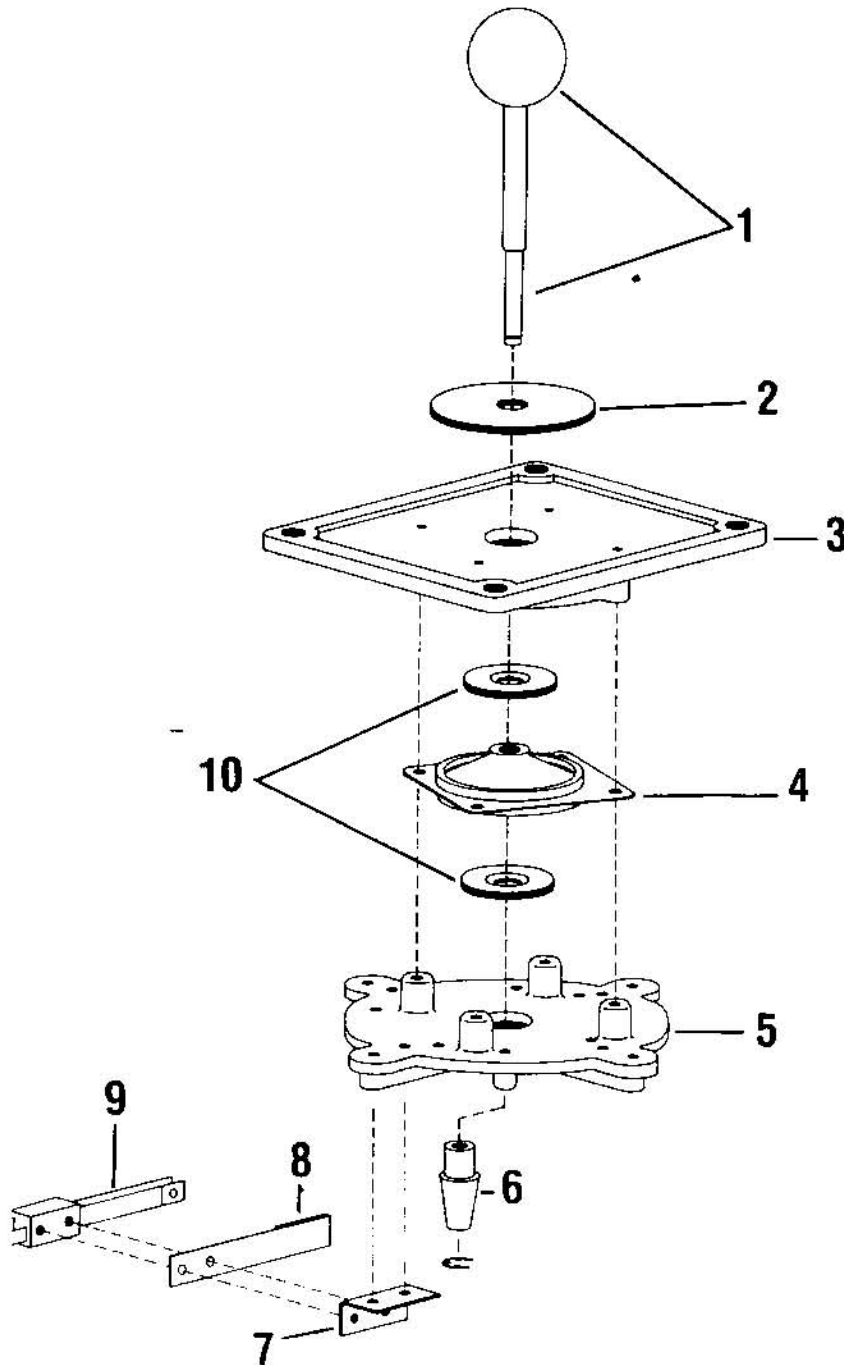

CONTROL PANEL

FIGURE 3

ITEM	TATIO PART NO.	DESCRIPTION
1	63B00031-001	Ball & Shaft
2	63B00024-003	Push Button (Yellow)
3	07M00051-004	Control Panel
4	63B00024-001	Push Button (White)
5	63C00025-001	Switch Support
6	54A07001-008	Stamped Nut $\frac{3}{8}$ -11
7	29B0016-001	Leaf Switch
8	42D00017-001	Dash Panel
9	63D00032-006	Control (8-Way Leaf Switch)
10	63B00030-001	Actuator
11	59B00020-017	"E" Ring
12	61A00015-001	Strike Hook
13	42B00106-001	Cleat
14	63D00076-001	Decal, Lexan

CONTROL PANEL

FIGURE 3

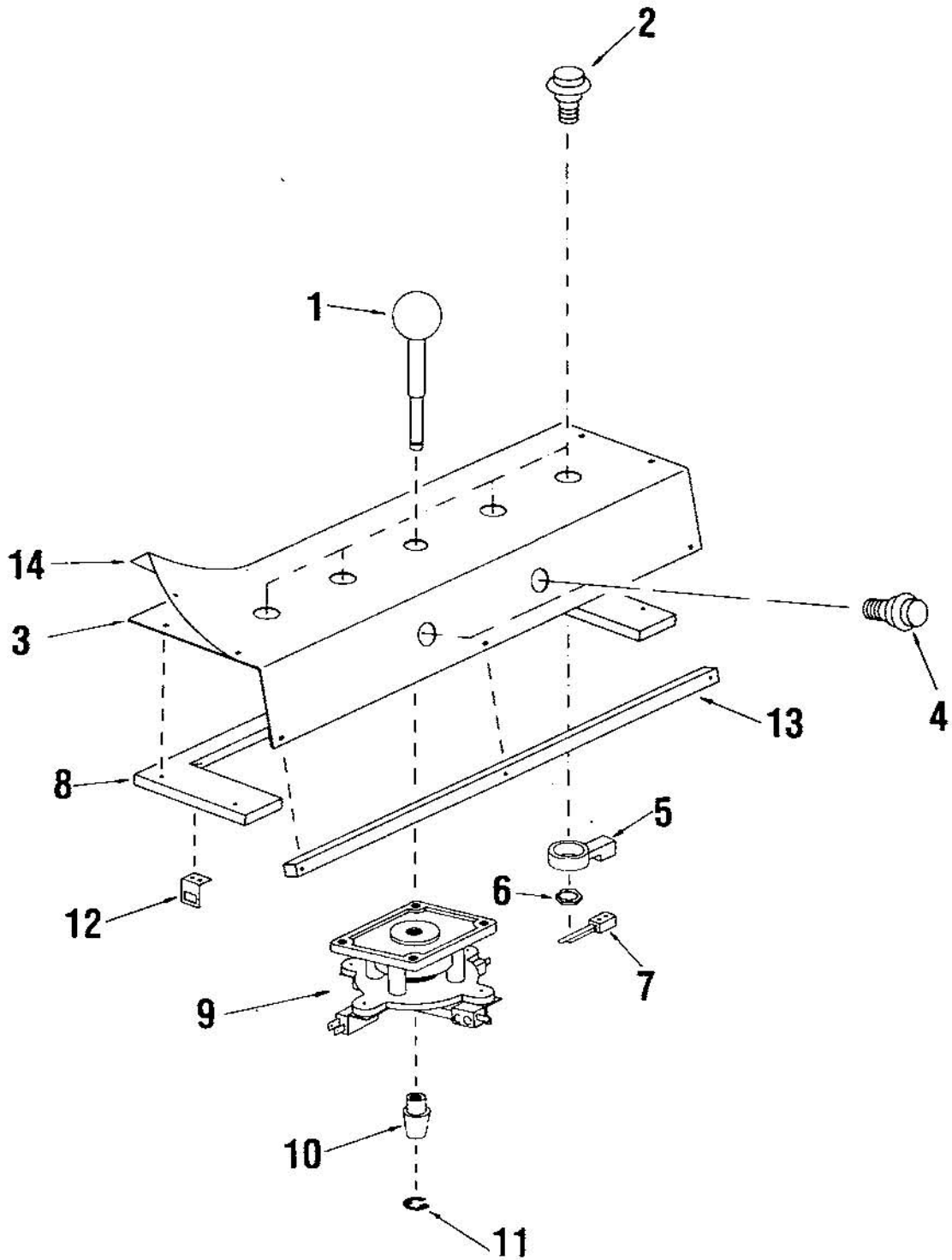

DOOR ASSEMBLY

FIGURE 4

ITEM	TAITO PART NO.	DESCRIPTION
1	04-00037-002	Lock Kit
2	61B00142-001	Lock Rod Assembly
3	01D00079-001	P.C. Board Mounting Plate
4	61A00111-001	Rod Lock Bracket
5	08-00029-001	Game P.C. Board Assembly
6	79-00031-001	L.E.D. Values Sheet

NOTES

DOOR ASSEMBLY

FIGURE 4

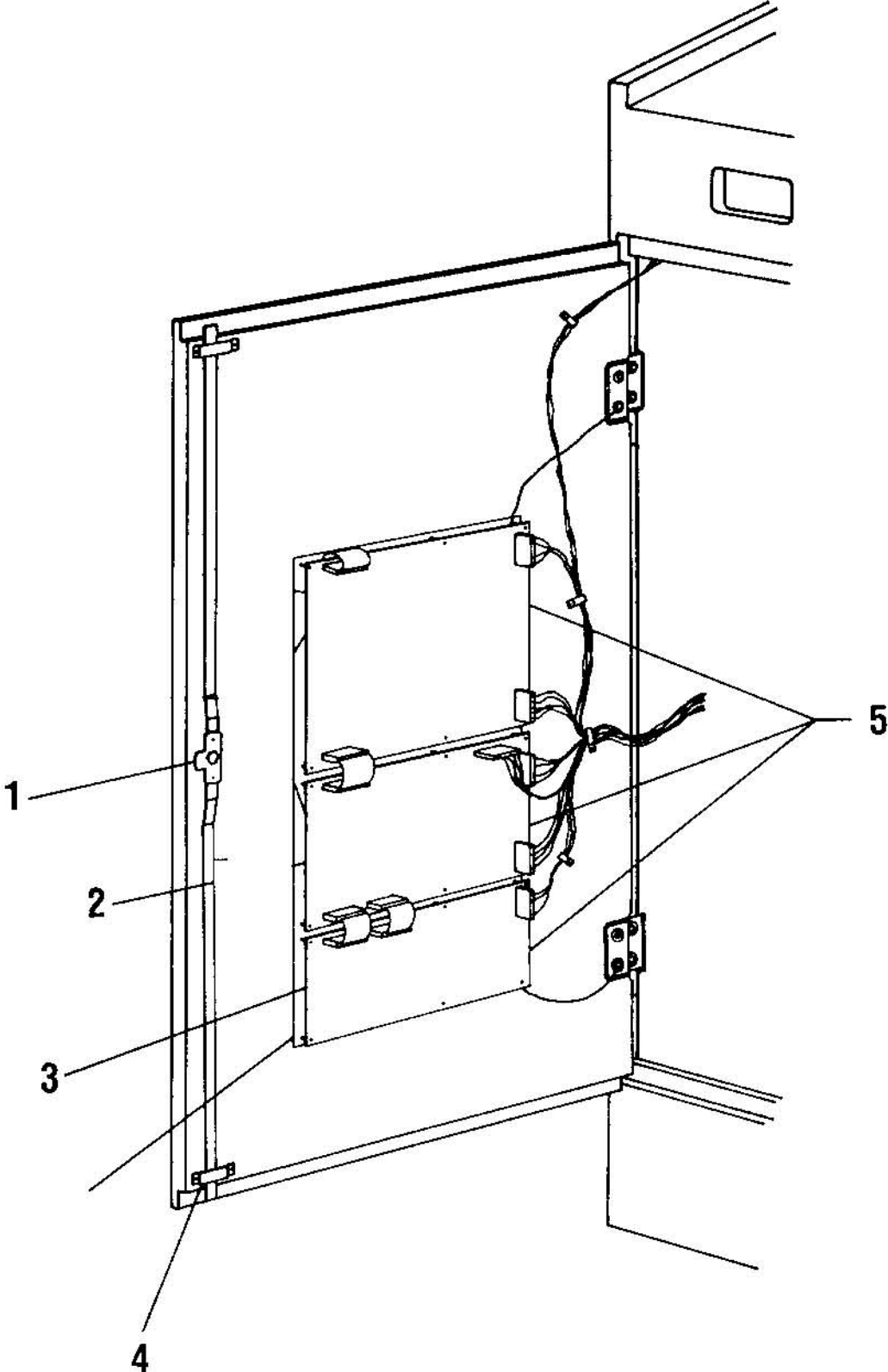

CABINET ASSEMBLY UPRIGHT FRONT VIEW

FIGURE 5

ITEM	TAITO PART NO.	DESCRIPTION
1	07M00055-002	Incandescent Panel
2	63B00006-001	63B00006-003 "U" Channel
3	47D00012-005	Marquee
4	61C00115-001	Marquee Retaining Bracket
5	61D00012-001	Lower Cover Glass Bracket
6	07M00052-004	Control Panel Assembly
7	07-00115-001	Coin Door
8	61B00113-001	Switch Bracket
9	07M00057-001	Service Switch Assembly
10	29-00022-001	Slide, Center Return Switch
11	29B00015-001	Interlock Switch
12	61B00114-001	Interlock Switch Bracket
13	59-00008-001	Latching Clamp
14	63B00002-004	"T" Molding
15	29A00023-001	Power ON/OFF Switch
16	41D00015-001	Finish Cabinet
17	07M00116-001	Volume Control Assembly
18	61C00212-001	Volume Control Bracket
19	29-00026-001	Switch Interlock Non Cheat

CABINET ASSEMBLY UPRIGHT FRONT VIEW

FIGURE 5

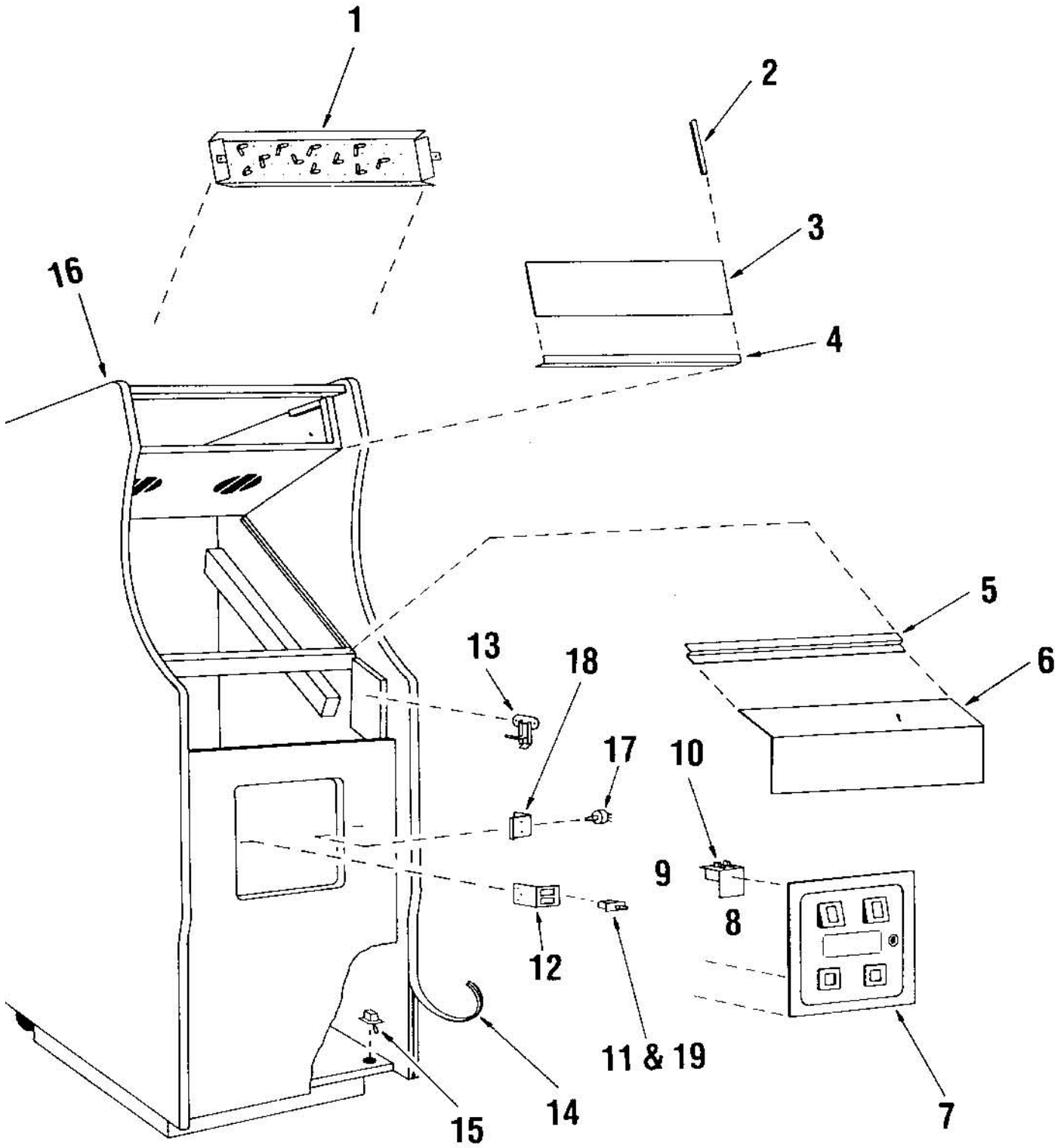

CABINET ASSEMBLY UPRIGHT REAR VIEW

FIGURE 6

ITEM	TAITO PART NO.	DESCRIPTION
1	21C00003-001	Speaker 6" round
2	61B00009-001	Speaker Grill
3	41D00015-001	Finished Cabinet
4	61C00006-001	Upper Cover Glass Bracket
5	63S00053-001	Monitor Shroud
6	61D00208-001	Monitor Mounting Bracket
7	27-00006-001	#47 Bulb, Lighted Instr.
8	26-00008-001	Socket, Snap-on Bayonet
9	47D00016-002	Cover Glass
10	44C00001-001	Wheels
11	63C00005-004	"L" Molding
12	07M00042-001	A/C Line Cord Assembly
13	63C00005-002	"L" Molding
14	61B00030-002	Interlock Bracket
*14A	59B00045-001	Switch Barrier
15	29B00015-001	Interlock Switch
16	07M00039-001	Power Supply
17	61C00054-001	Cash Box Lid
18	31-00004-001	19" (Horz.) Color Monitor
19	63-00019-001	Cash Tray Separator
20	61-00039-001	Cash Tray Handle
21	61C00060-001	Cash Box
22	63-00010-001	Cash Tray (Only)
23	07M00054-001	Cash Tray Assembly
24	42C00013-001	Monitor Support Cleat
25	08M00002-002	Data/Sound P.C.B.
26	61B00142-001	Lock Rod Assembly
27	08M00030-001	ROM/10 P.C.B.
28	04M00037-002	Lock Kit
29	08M00001-002	Video Processor P.C.B.
30	61D00079-001	P.C.B. Mtg. Plate

NOTE:

Item not shown on drawing

CABINET ASSEMBLY UPRIGHT REAR VIEW

FIGURE 6

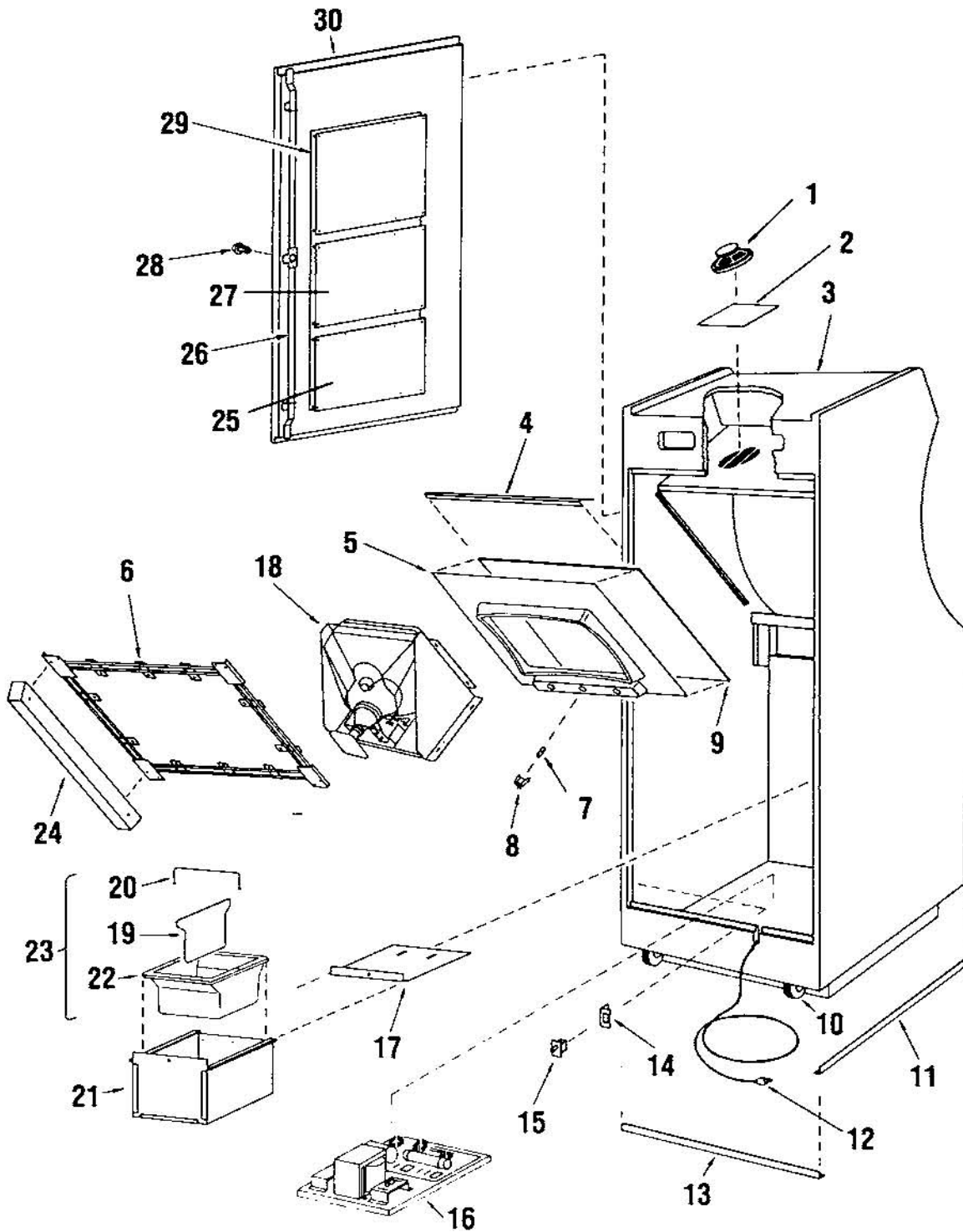

FIGURE 7

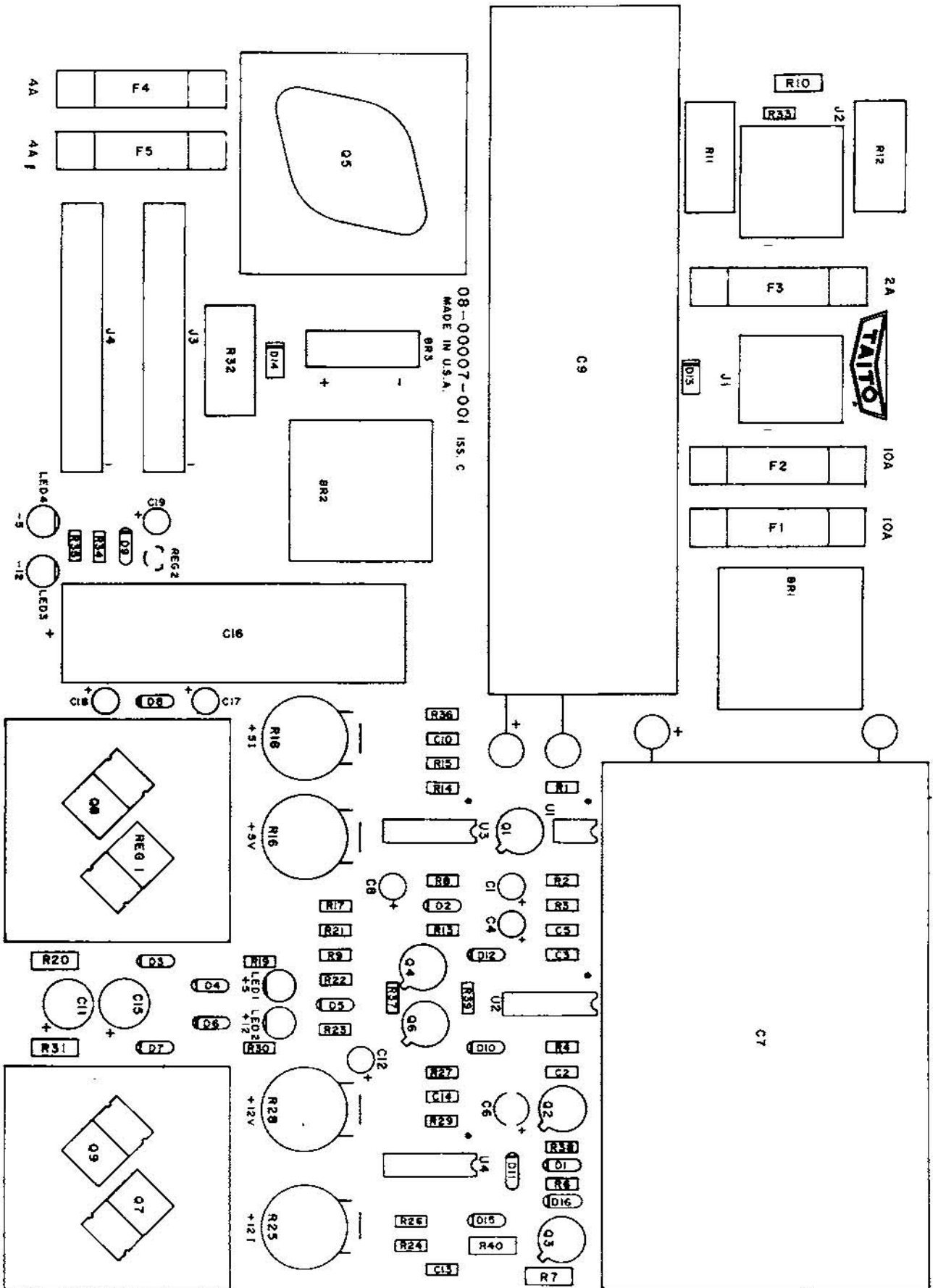

FIGURE 7

SYM	TAITO PART NO.	DESCRIPTION
R1	11-00001-102	Resistor 1.0K 5% ¼W 5%
R2	11-00001-512	Resistor 5.1K ¼W 5%
R3	11-00001-183	Resistor 18K ¼W 5%
R4	11-00001-224	Resistor 220K ¼W 5%
R5	11-00001-472	Resistor 4.7K ¼W 5%
R6	11-00001-222	Resistor 2.2K ¼W 5%
R7	11-10001-101	Resistor 100 ¼W 5%
R8	11-00001-102	Resistor 10K ¼W 5%
R9	11-00001-472	Resistor 4.7K ¼W 5%
R10	11-10001-101	Resistor 100 ½W 5%
R11	11-30001-015	Resistor .15 4W 5%
R12	11-30001-015	Resistor .15 4W 5%
R13	11-00001-472	Resistor 4.7K ¼W 5%
R14	11-00001-222	Resistor 2.2K ¼W 5%
R15	11-00001-222	Resistor 2.2K ¼W 5%
R16	11-60001-252	Pot 2.5K ¼W 20%
R17	11-00001-222	Resistor 2.2K ¼W 5%
R18	11-60001-102	Pot 1.0K ¼W 20%
R19	11-00001-511	Resistor 510 ¼W 5%
R20	11-10001-470	Resistor 47 ½W 5%
R21	11-00001-162	Resistor 1.6K ¼W 5%
R22	11-00001-103	Resistor 10K ¼W 5%
R23	11-00001-472	Resistor 4.7K ¼W 34
R24	11-00001-222	Resistor 2.2K ¼W 5%
R25	11-60001-102	Pot 1.0K ¼W 5%
R26	11-00001-472	Resistor 407K ¼W 5%
R27	11-00001-222	Resistor 2.2K ¼W 5%
R28	11-60001-252	Pot 2.5K ¼W 20%
R29	11-00001-472	Resistor 4.7K ¼W 5%
R30	11-00001-122	Resistor 1.2K ¼W 5%
R31	11-10001-470	Resistor 47 ¼W 5%
R32	11-30001-015	Resistor .15 4W 5%
R33	11-00001-222	Resistor 2.2K ¼W 5%
R34	11-00001-122	Resistor 1.2K ¼W 5%
R35	11-00001-511	Resistor 510 ¼W 5%
R36	11-00001-222	Resistor 2.2K ¼W 5%
R37	11-00001-104	Resistor 100K
R38	11-00001-103	Resistor 10K ¼W 5%
R39	11-00001-224	Resistor 220L ¼W 5%
R40*	11-00001-225	Resistor 20HM ¼W
C1	12-30001-225	Capacitor, Tantalum 2.2uf 25V
C2	12-10004-103	Capacitor, Ceramic 01uf
C3	12-10004-103	Capacitor, Ceramic .01uf
C4	12-30001-105	Capacitor, Tantalum 1.uf 35V

SYM	TAITO PART NO.	DESCRIPTION
C5	12-10001-102	Capacitor, .001uf
C6	12-30001-106	Capacitor, Tantalum 10uf
C7	12-20003-509	Capacitor, Electrolytic 50,000uf
C8	12-30001-105	Capacitor, Tantalum 1.uf 35V
C9	12-20003-209	Capacitor, Electrolytic 20,000uf
C10	12-10001-332	Capacitor, Ceramic .0033uf
C11	12-30001-476	Capacitor, Tantalum 47uf
C12	12-30001-105	Capacitor, Tantalum 1.uf 35V
C13	12-10004-103	Capacitor, Ceramic .01uf
C14	12-10001-102	Capacitor, .001uf
C15	12-30001-476	Capacitor, Tantalum 47uf
C16	12-20002-108	Capacitor, Electrolytic 1,000uf
C17	12-30001-225	Capacitor, Tantalum 2.2uf 25V
C18	12-30001-225	Capacitor, Tantalum 2.2uf 25V
C19	12-30001-105	Capacitor, Tantalum 1.uf 35V
F1	24-00003-010	10A Fuse
F2	24-00003-010	10A Fuse
F3	24-00003-003	Fuse, 2A
F4**	24-00003-004	Fuse, 4A was labeled 5A
F5**	24-00003-004	Fuse, 4A was labeled 5A
BR1	13-00100-025	Diode Bridge 25A, 100V
BR2	13-00100-012	Diode Bridge 12A, 100V
BR3	13-00100-002	Diode Bridge 2A, 100V
D1	13-14002-001	Diode IN4002
D2	13-14002-001	Diode IN4002
D3	13-10752-001	Diode, Zener IN752
D4	13-14002-001	Diode IN4002
D5	13-14002-001	Diode IN4002
D6	13-14002-001	Diode IN4002
D7	13-10964-001	Diode, Zener IN964
D8	13-14002-001	Diode IN4002
D9	13-14002-001	Diode IN4002
D10	13-14002-001	Diode IN4002
D11	13-14002-001	Diode IN4002
D12	13-14002-001	Diode IN4002
D13*	13-14002-001	Diode IN6276 or 1.5KE 16
D14*	13-14002-001	Diode IN6218 or 1.5KE 27
D15*	13-14002-001	Diode IN4002
D16*	13-14002-001	Diode IN4002
LED1	13-00001-001	LED (Red)
LED2	13-00001-001	LED (Red)
LED3	13-00001-001	LED (Red)
LED4	13-00001-001	LED (Red)
U1	15-62500-001	Opto Coupler H11AA2
U2	15-50556-001	Timer (Dual) 556
U3	15-50723-001	Voltage Regulator 723
U4	15-50723-001	Voltage Regulator 723

POWER SUPPLY

FIGURE 7

SYM	TAITO PART NO.	DESCRIPTION
REG1	15-57912-001	Voltage Regulator 7912
REG2	15-57905-001	Voltage Regulator 79L05
Q1	14-22905-001	Transistor 2N2905
Q2	14-22905-001	Transistor 2N2905
Q3	14-22905-001	Transistor 2N2905
Q4	14-22905-001	Transistor 2N2905
Q5	14-23055-001	Transistor 2N3055
Q6	14-22905-001	Transistor 2N2905
Q7	14-20030-001	Transistor TIP-30A
Q8	14-26401-001	SCR 2N6401
Q9	14-26401-001	SCR 2N6401
J1	25-00022-006	Connector, 1-380999-0 6Pin
J2	25-00022-008	Connector, 350212-1 8Pin
J3	25-00002-014	Connector, 09-60-1141 14Pin
J4	25-00002-014	Connector, 09-60-1140 14Pin
	24-10001-001	Fuse Clips
	30-00220-002	Heat Sink Dual To-220
	30-00003-001	Heat Sink Single To-3

NOTE:

*Components add to Rev B

**Changes in labeling components

FIGURE 8

SYM	TAITO PART NO.	DESCRIPTION
C99	12-10002-104	Capacitor Ceramic, .1uf, 50V, +80/ -20%
C100	12-10002-104	Capacitor Ceramic, .1uf, 50V, +80/ -20%
C101	12-10003-100	Capacitor Ceramic, 10pf, 10% NPO Axial Lead 20%
C102	12-10002-104	Capacitor Ceramic, .1uf, 50V, +80/ -20%
C103	12-10002-104	Capacitor Ceramic, .1uf, 50V, +80/ -20%
C104	12-10002-104	Capacitor Ceramic, .1uf, 50V, +80/ -20%
C105	12-10002-104	Capacitor Ceramic, .1uf, 50V, +80/ -20%
C106	12-10002-104	Capacitor Ceramic, .1uf, 50V, +80/ -20%
C107	12-10002-104	Capacitor Ceramic, .1uf, 50V, +80/ -20%
C108	12-10002-104	Capacitor Ceramic, .1uf, 50V, +80/ -20%
C113	12-10001-471	Capacitor Ceramic, 50V, 10% 470PF Axial Lead
C114	12-10002-104	Capacitor, .1uf, 50V +80/ -20%
R1	11-00001-330	Resistor 33 OHM, 1/4W, 5%
R2	11-00001-152	Resistor 1.5K, 1/4W, 5%
R3	11-00001-271	Resistor 270 OHM, 1/4W, 5%
R4	11-00001-271	Resistor 270 OHM, 1/4W, 5%
R5	11-00001-271	Resistor 270 OHM, 1/4W, 5%
R6	11-00001-332	Resistor 3.3K, 1/4W, 5%
R7	11-00001-221	Resistor 220 OHM, 1/4W, 5%
R8	11-00001-222	Resistor 2.2K, 1/4W, 5%
R9	11-00001-330	Resistor 33 OHM, 1/4W, 5%
R10	11-00001-330	Resistor 33 OHM, 1/4W, 5%
R11	11-00001-330	Resistor 33 OHM, 1/4W, 5%
R12	11-00001-330	Resistor 33 OHM, 1/4W, 5%
R13	11-00001-820	Resistor 82 OHM, 1/4W, 5%
R14	11-00001-181	Resistor 180 OHM, 1/4W, 5%
R15	11-00001-271	Resistor 270 OHM, 1/4W, 5%
R16	11-00001-151	Resistor 150 OHM, 1/4W, 5%
R17	11-00001-151	Resistor 150 OHM, 1/4W, 5%
R18	11-00001-271	Resistor 270 OHM, 1/4W, 5%
R19	11-00001-181	Resistor 180 OHM, 1/4W, 5%
R20	11-00001-820	Resistor 82 OHM, 1/4W, 5%
R21	11-00001-330	Resistor 33 OHM, 1/4W, 5%
R22	11-00001-330	Resistor 33 OHM, 1/4W, 5%
R23	11-00001-330	Resistor 33 OHM, 1/4W, 5%
R24	11-00001-330	Resistor 33 OHM, 1/4W, 5%
R25	11-00001-330	Resistor 33 OHM, 1/4W, 5%
R26	11-00001-330	Resistor 33 OHM, 1/4W, 5%
R27	11-00001-330	Resistor 33 OHM, 1/4W, 5%
R28	11-00001-181	Resistor 180 OHM, 1/4W, 5%
R29	11-00001-471	Resistor 470 OHM, 1/4W, 5%
R30	11-00001-471	Resistor 470 OHM, 1/4W, 5%
R31	11-00001-471	Resistor 470 OHM, 1/4W, 5%
R32	11-00001-471	Resistor 470 OHM, 1/4W, 5%
R33	11-00001-471	Resistor 470 OHM, 1/4W, 5%
R34	11-00001-681	Resistor 680 OHM, 1/4W, 5%
R35	11-00001-391	Resistor 390 OHM, 1/4W, 5%
R36	11-00001-330	Resistor 33 OHM, 1/4W, 5%

SYM	TAITO PART NO.	DESCRIPTION
R37	11-00001-473	Resistor 47K OHM, 1/4W, 5%
R38	11-00001-332	Resistor 3300 OHM, 1/4W, 5%
R39	11-00001-331	Resistor 330 OHM, 1/4W, 5%
R40	11-00001-331	Resistor 330 OHM, 1/4W, 5%
R41	11-00001-331	Resistor 330 OHM, 1/4W, 5%
R42	11-00001-331	Resistor 330 OHM, 1/4W, 5%
R43	11-00001-331	Resistor 330 OHM, 1/4W, 5%
R44	11-00001-331	Resistor 330 OHM, 1/4W, 5%
R45	11-00001-151	Resistor 150 OHM, 1/4W, 5%
R46	11-00001-820	Resistor 82 OHM, 1/4W, 5%
R47	11-00001-471	Resistor 470 OHM, 1/4W, 5%
R48	11-00001-181	Resistor 180 OHM, 1/4W, 5%
R49	11-00001-271	Resistor 270 OHM, 1/4W, 5%
R50	11-00001-473	Resistor 47K OHM, 1/4W, 5%
R51	11-00001-330	Resistor 33 OHM, 1/4W, 5%
R52	11-00001-330	Resistor 33 OHM, 1/4W, 5%
R53	11-00001-330	Resistor 33 OHM, 1/4W, 5%
R54	11-00001-330	Resistor 33 OHM, 1/4W, 5%
R55	11-00001-330	Resistor 33 OHM, 1/4W, 5%
R56	11-00001-330	Resistor 33 OHM, 1/4W, 5%
R57	11-00001-330	Resistor 33 OHM, 1/4W, 5%
R58	11-00001-330	Resistor 33 OHM, 1/4W, 5%
R59	11-00001-473	Resistor 47K OHM, 1/4W, 5%
R60	11-00001-332	Resistor 3300 OHM, 1/4W, 5%
R61	11-00001-391	Resistor 390 OHM, 1/4W, 5%
R62	11-00001-332	Resistor 3.3K, 1/4W, 5%
R63	11-00001-102	Resistor 1K, 1/4W, 5%
R64	11-00001-121	Resistor 120 OHM, 1/4W, 5%
R65	11-00001-151	Resistor 150 OHM, 1/4W, 5%
R66	11-00001-332	Resistor 3.3K, 1/4W, 5%
R67	11-00001-332	Resistor 3300 OHM, 1/4W, 5%
R68	11-00001-332	Resistor 3.3K, 1/4W, 5%
R69	11-00001-332	Resistor 3.3K, 1/4W, 5%
R70	11-00001-472	Resistor 4.7K, 1/4W, ±5%
FB1	17-00001-001	Ferrite Bead
FB2	17-00001-001	Ferrite Bead
FB3	17-00001-001	Ferrite Bead
FB4	17-00001-001	Ferrite Bead
FB5	17-00001-001	Ferrite Bead
FB6	17-00001-001	Ferrite Bead
FB7	17-00001-001	Ferrite Bead
FB8	17-00001-001	Ferrite Bead
FB9	17-00001-001	Ferrite Bead
FB10	17-00001-001	Ferrite Bead
FB14	17-00001-001	Ferrite Bead
Q1	14-23904-001	Transistor NPN Silicon (2N3904)
Q2	14-23904-001	Transistor NPN Silicon (2N3904)
Q3	14-23904-001	Transistor NPN Silicon (2N3904)
Q4	14-23904-001	Transistor NPN Silicon (2N3904)

FIGURE 8

SYM	TAITO PART NO.	DESCRIPTION
Q5	14-23904-001	Transistor NPN Silicon (2N3904)
Q6	14-23904-001	Transistor NPN Silicon (2N3904)
Q7	14-23904-001	Transistor NPN Silicon (2N3904)
Q8	14-23905-001	Transistor NPN Silicon (2N3905)
LED1	13-00001-001	L.E.D. RED, TL-1%
LED2	13-00001-001	L.E.D. RED, TL-1%
LED3	13-00001-001	L.E.D. RED, TL-1%
LED4	13-00001-001	L.E.D. RED, TL-1%
LED5	13-00001-001	L.E.D. RED, TL-1%
LED6	13-00001-001	L.E.D. RED, TL-1%
Y1	19-00003-001	CRYSTAL, 20,000MHZ
BATT	20-00001-001	Battery, NICAD, 3.6V, 1/3 AA
SW1	29-00017-001	Switch Momentary
TP1	59-00021-001	Test Point
TP2	59-00021-001	Test Point
TP3	59-00021-001	Test Point
TP4	59-00021-001	Test Point
TP5	59-00021-001	Test Point
TP6	59-00021-001	Test Point
TP7	59-00021-001	Test Point
TP8	59-00021-001	Test Point
RP1	11-50001-102	1K OHM Resistor Sip Pack
RP2	11-50001-473	47K OHM Resistor Sip Pack
RP3	11-50001-332	3.3K Resistor Sip Pack
RP4	11-50001-332	3.3K Resistor Sip Pack
RP5	11-50001-332	3.3K Resistor Sip Pack
J1	25-00001-014	Connector, 14 Pin .156 Center
J2	25-00002-014	Connector, 14 Pin .156 Center
J3	25-00001-001	Connector, 50 Pin Header Vertical
J6	25-00001-001	Connector, 50 Pin Header Vertical
J19	25-00002-002	Connector, 2 Pin .156 Center
W1	25-00021-002	Connector .1 Center for W1
W1	26-00007-001	Shorting Pin
	32-00001-001	P.C.B. Video Processor Board
U1	15-20245-001	Bus Transciever, Octal (74LS245)
U2	15-20245-001	Bus Transciever, Octal (74LS245)
U3	15-10003-001	Ram 1K x 4 NMOS Static (2114)
	26-00001-018	Socket DIP 18 Pin for U3
U4	15-10003-001	Ram 1K x 4 NMOS Static (2114)
	26-00001-018	Socket DIP 18 Pin for U4
U5	15-20157-001	Multiplexer Quad 2-Input (74LS157)
U6	15-20157-001	Multiplexer Quad 2-Input (74LS157)
U7	15-20074-001	Flip Flop, Dual D (74LS74)
U8	15-20032-001	Quad 2 Input or (74LS32)
U9	15-20032-001	Quad 2 Input or (74LS32)
U10	15-10001-001	RAM 16K x 1 Dynamic (4116)
	26-00001-016	Socket DIP 16 Pin for U10

SYM	TAITO PART NO.	DESCRIPTION
U11	15-10001-001	RAM 16K x 1 Dynamic (4116)
	26-00001-016	Socket DIP 16 Pin for U11
U12	15-10001-001	RAM 16K x 1 Dynamic (4116)
	26-00001-016	Socket DIP 16 Pin for U12
U13	15-10001-001	RAM 16K x 1 Dynamic (4116)
	26-00001-016	Socket DIP 16 Pin for U13
U14	15-10001-001	RAM 16K x 1 Dynamic (4116)
	26-00001-016	Socket DIP 16 Pin for U14
U15	15-10001-001	RAM 16K x 1 Dynamic (4116)
	26-00001-016	Socket DIP 16 Pin for U15
U16	15-10001-001	RAM 16K x 1 Dynamic (4116)
	26-00001-016	Socket DIP 16 Pin for U16
U17	15-10001-001	RAM 16K x 1 Dynamic (4116)
	26-00001-016	Socket DIP 16 Pin for U17
U18	15-00003-001	CRT CONTROLLER 68A45
	26-00001-040	Socket DIP 40 Pin for U18
U19	15-20086-001	Quad 2 Input Exclusive or (74LS86)
U20	15-20086-001	Quad 2 Input Exclusive or (74LS86)
U21	15-20157-001	Multiplexer Quad 2-Input (74LS157)
U22	15-20032-001	Quad 2 Input or (74LS157)
U23	15-20161-001	Counter, 4 Bit Presetable (74LS161)
U24	15-20004-001	Inverter, HEX (74LS04)
U25	15-70374-001	Latch, Octal Shockey (74LS374)
U26	15-10001-001	RAM 16K x1 Dynamic (4116)
	26-00001-016	Socket DIP 16 Pin for U26
U27	15-10001-001	RAM 16K x1 Dynamic (4116)
	26-00001-016	Socket DIP 16 Pin for U27
U28	15-10001-001	RAM 16K x1 Dynamic (4116)
	26-00001-016	Socket DIP 16 Pin for U28
U29	15-10001-001	RAM 16K x1 Dynamic (4116)
	26-00001-016	Socket DIP 16 Pin for U29
U30	15-10001-001	RAM 16K x1 Dynamic (4116)
	26-00001-016	Socket DIP 16 Pin for U30
U31	15-10001-001	RAM 16K x1 Dynamic (4116)
	26-00001-016	Socket DIP 16 Pin for U31
U32	15-10001-001	RAM 16K x1 Dynamic (4116)
	26-00001-016	Socket DIP 16 Pin for U32
U33	15-10001-001	RAM 16K x1 Dynamic (4116)
	26-00001-016	Socket DIP 16 Pin for U33
U34	15-20374-001	Latch, Octal (74LS374)
U35	15-20153-001	Multiplexer, Dual 4-Input (74LS153)
U36	15-20074-001	Flip Flop Dual-D (74LS74)
U37	15-20008-001	Quad, 2-Input and (74LS08)
U38	15-70113-001	Flip Flop JK Schottky (74LS113)
U39	15-20004-001	Inverter, HEX (74LS04)
U40	15-30017-001	Buffer/Driver, HEX (7417)
U41	15-10001-001	RAM 16K x 1 Dynamic (4116)
	26-00001-016	Socket DIP 16 Pin for U41

FIGURE 8

SYM	TAITO PART NO.	DESCRIPTION
U42	15-10001-001	RAM 16K x 1 Dynamic (4116)
	26-00001-016	Socket DIP 16 Pin for U42
U43	15-10001-001	RAM 16K x 1 Dynamic (4116)
	26-00001-016	Socket DIP 16 Pin for U43
U44	15-10001-001	RAM 16K x 1 Dynamic (4116)
	26-00001-016	Socket DIP 16 Pin for U44
U45	15-10001-001	RAM 16K x 1 Dynamic (4116)
	26-00001-016	Socket DIP 16 Pin for U45
U46	15-10001-001	RAM 16K x 1 Dynamic (4116)
	26-00001-016	Socket DIP 16 Pin for U46
U47	15-10001-001	RAM 16K x 1 Dynamic (4116)
	26-00001-016	Socket DIP 16 Pin for U47
U48	15-10001-001	RAM 16K x 1 Dynamic (4116)
	26-00001-016	Socket DIP 16 Pin for U48
U49	15-20032-001	Quad 2-Input or (74LS32)
U50	15-20086-001	Quad 2-Input Exclusive or (74LS86)
U51	15-20086-001	Quad 2-Input Exclusive or (74LS86)
U52	15-20153-001	Multiplexer, Dual 4-Input (74LS153)
U53	15-20153-001	Multiplexer, Dual 4-Input (74LS153)
U54	15-20153-001	Multiplexer, Dual 4-Input (74LS153)
U55	15-20157-001	Multiplexer, Quad 2-Input (74LS157)
U56	15-10008-001	RAM 1K x 4 HMOS Static (2148)
	26-00001-018	Socket DIP 18 Pin for U56
U57	15-10008-001	RAM 1K x 4 HMOS Static (2148)
	26-00001-018	Socket DIP 18 Pin for U57
U58	15-30017-001	Buffer/Driver, HEX (7417)
U59	15-10001-001	RAM 16K x 1 Dynamic (4116)
U60	15-10001-001	RAM 16K x 1 Dynamic (4116)
U61	15-10001-001	RAM 16K x 1 Dynamic (4116)
U62	15-10001-001	RAM 16K x 1 Dynamic (4116)
U63	15-10001-001	RAM 16K x 1 Dynamic (4116)
U64	15-10001-001	RAM 16K x 1 Dynamic (4116)
U65	15-10001-001	RAM 16K x 1 Dynamic (4116)
U66	15-10001-001	RAM 16K x 1 Dynamic (4116)
U67	15-20032-001	Quad 2-Input or (74LS32)
U68	15-20244-001	Octal Buffer (74LS244)
U69	15-20245-001	BUS Transceiver, Octal (74LS245)
U70	15-20374-001	Latch, Octal (74LS374)
U71	15-20374-001	Latch, Octal (74LS374)
U72	15-20374-001	Latch, Octal (74LS374)
U73	15-20157-001	Multiplexer Quad 2-Input (74LS157)
U74	15-20157-001	Multiplexer Quad 2-Input (74LS157)
U75	15-20245-001	BUS Transceiver, Octal (74LS245)
U76	15-20273-001	Register 8 Bit (74LS273)
U77	15-20373-001	Latch, Octal (74LS373)
U78	15-20373-001	Latch, Octal (74LS373)
U79	15-20373-001	Latch, Octal (74LS373)
U80	15-20373-001	Latch, Octal (74LS373)

SYM	TAITO PART NO.	DESCRIPTION
U81	15-20157-001	Multiplexer Quad 2-Input (74LS157)
U82	15-00002-001	Microprocessor 68A09E
	26-00001-040	Socket DIP 40 Pin for U82
U83	15-20244-001	Octal, Buffer (74LS244)
U84	15-20244-001	Octal, Buffer (74LS244)
U85	15-10002-001	RAM 1K x 4 CMOS Static (6514)
	26-00001-018	Socket DIP 18 Pin for U85
U86	15-10002-001	RAM 1K x 4 CMOS Static (6514)
	26-00001-018	Socket DIP 18 Pin for U86
U87	15-20139-001	Decoder Dual 1 of 4 (74LS139)
U88	15-20032-001	Quad 2-Input or (74LS32)
U89	15-20074-001	Flip Flop, Dual-D (74LS74)
U90	15-20004-001	Inverter, HEX (74LS04)
U91	15-20374-001	Latch, Octal (74LS374)
U92	15-20374-001	Latch, Octal (74LS374)
U93	15-20374-001	Latch, Octal (74LS374)
U94	15-20374-001	Latch, Octal (74LS374)
U95	15-20299-001	Shift Register 8 Bit (74LS299)
U96	15-20299-001	Shift Register 8 Bit (74LS299)
U97	15-20244-001	Buffer, Octal (74LS244)
U98	15-20244-001	Buffer, Octal (74LS244)
U99	15-20138-001	Decoder, 1 of 8 (74LS138)
U100	15-40000-001	Quad 2-Input NOR (74C00)
U101	15-20008-001	Quad 2-Input AND (74LS08)
U102	15-20010-001	Triple 3-Input AND (74LS10)
U103	15-20000-001	Quad 2-Input NAND (74LS00)
U104	15-20157-001	Multiplexer Quad 2-Input (74LS157)
U105	15-20299-001	Shift Register 8 Bit (74LS299)
U106	15-20299-001	Shift Register 8 Bit (74LS299)
U107	15-20299-001	Shift Register 8 Bit (74LS299)
U108	15-20299-001	Shift Register 8 Bit (74LS299)
U109	15-20299-001	Shift Register 8 Bit (74LS299)
U110	15-20299-001	Shift Register 8 Bit (74LS299)

FIGURE 9

SYM	TAITO PART NO.	DESCRIPTION
R1	11-00001-473	Resistor 47K ¼W ±5%
R2	11-00001-332	Resistor 3.3K ¼W ±5%
R3	11-00001-332	Resistor 3.3K ¼W ±5%
R4	11-00001-332	Resistor 3300 OHM ¼W ±5%
R5	11-00001-472	Resistor 4.7K ¼W ±5%
R6	11-00001-103	Resistor 4.7K ¼W ±5%
R7	11-00001-103	Resistor 10K ¼W ±5%
R8	11-00001-332	Resistor 3.3K OHM ¼W ±5%
R9	11-60001-502	Pot, P.C. Mount 5K
R10	11-00001-473	Resistor 47K ¼W ±5%
R11	11-00001-473	Resistor 47K ¼W ±5%
R12	11-00001-332	Resistor 3.3K ¼W ±5%
R13	11-00001-332	Resistor 3.3K ¼W ±5%
R14	11-00001-332	Resistor 3.3K ¼W ±5%
R15	11-00001-332	Resistor 3.3K ¼W ±5%
R16	11-00001-682	Resistor 6.8K ¼W ±5%
R17	11-00001-332	Resistor 3.3K OHM ¼W ±5%
R18	11-00001-124	Resistor 120K ¼W ±5%
R19	11-00001-472	Resistor 4.7K ¼W ±5%
R20	11-00001-221	Resistor 220 OHM ¼W ±5%
R21	11-00001-221	Resistor 220 OHM ¼W ±5%
R22	11-00001-332	Resistor 3.3K ¼W ±5%
R24	11-00001-182	Resistor 1.8K ¼W ±5%
R25	11-60001-104	POT, P.C. Mount 100K
R26	11-00001-103	Resistor 10K ¼W ±5%
R27	11-00001-103	Resistor 10K ¼W ±5%
R28	11-00001-223	Resistor 22K ¼W ±5%
R29	11-00001-562	Resistor 5.6K ¼W ±5%
R30	11-00001-332	Resistor 3.3K ¼W ±5%
R31	11-00001-020	Resistor 2.2 OHM ¼W ±5%
R32	11-00001-010	Resistor 1 OHM ½W ±5%
R33	11-00001-020	Resistor 2.2 OHM ¼W ±5%
R34	11-00001-010	Resistor 1 OHM ½W ±5%
R35	11-00001-102	Resistor 1.0K OHM ¼W ±5%
R36	11-00001-332	Resistor 3.3K ¼W ±5%
R37	11-00001-152	Resistor 1.5K ¼W ±5%
R38	11-00001-222	Resistor 2.2K ¼W ±5%
R39	11-00001-221	Resistor 220 OHM ¼W ±5%
R40	11-00001-332	Resistor 3.3K ¼W ±5%
R41	11-00001-562	Resistor 5.6K ¼W ±5%
R42	11-00001-223	Resistor 22K ¼W ±5%
R43	11-00001-103	Resistor 10K ¼W ±5%
R44	11-00001-103	Resistor 10K ¼W ±5%
R45	11-00001-103	Resistor 10K ¼W ±5%
R50	11-00001-472	Resistor 4.7K ¼W ±5%
FB1	17-00001-001	Ferrite Bead
FB2	17-00001-001	Ferrite Bead
FB3	17-00001-001	Ferrite Bead
FB4	17-00001-001	Ferrite Bead

SYM	TAITO PART NO.	DESCRIPTION
FB5	17-00001-001	Ferrite Bead
FB8	17-00001-001	Ferrite Bead
FB9	17-00001-001	Ferrite Bead
FB10	17-00001-001	Ferrite Bead
FB11	17-00001-001	Ferrite Bead
FB13	17-00001-001	Ferrite Bead
FB14	17-00001-001	Ferrite Bead
FB15	17-00001-001	Ferrite Bead
FB16	17-00001-001	Ferrite Bead
FB17	17-00001-001	Ferrite Bead
FB18	17-00001-001	Ferrite Bead
FB19	17-00001-001	Ferrite Bead
FB20	17-00001-001	Ferrite Bead
C1	12-10002-104	Capacitor Ceramic .1uf 50V Axial Lead
C2	12-10002-104	Capacitor Ceramic .1uf 50V Axial Lead
C3	12-10002-104	Capacitor Ceramic .1uf 50V Axial Lead
C4	12-10002-104	Capacitor Ceramic .1uf 50V Axial Lead
C5	12-10002-104	Capacitor Ceramic .1uf 50V Axial Lead
C6	12-10002-104	Capacitor Ceramic .1uf 50V Axial Lead
C7	12-20001-107	Capacitor Electrolytic 100uf 16V
C8	12-20001-107	Capacitor Electrolytic 100uf 16V
C9	12-20001-107	Capacitor Electrolytic 100uf 16V
C10	12-20001-107	Capacitor Electrolytic 100uf 16V
C11	12-20001-107	Capacitor Electrolytic 100uf 16V
C12	12-10002-104	Capacitor Ceramic .1uf 50V Axial Lead
C13	12-10002-104	Capacitor Ceramic .1uf 50V Axial Lead
C14	12-10002-104	Capacitor Ceramic .1uf 50V Axial Lead
C15	12-10002-104	Capacitor Ceramic .1uf 50V Axial Lead
C16	12-10002-104	Capacitor Ceramic .1uf 50V Axial Lead
C17	12-10002-104	Capacitor Ceramic .1uf 50V Axial Lead
C18	12-10002-104	Capacitor Ceramic .1uf 50V Axial Lead
C19	12-10003-470	Capacitor 47pf 10% NPO Axial Lead
C20	12-20001-105	Capacitor Electrolytic 1uf
C21	12-10002-104	Capacitor Ceramic .1uf 50V Axial Lead
C22	12-20001-807	Capacitor Electrolytic 800uf, 16V
C23	12-20001-807	Capacitor Electrolytic 800uf, 16V
C24	12-10001-471	Capacitor Ceramic 470pf 50V 10% Axial Lead
C25	12-10001-471	Capacitor Ceramic 470pf 50V 10% Axial Lead
C26	12-10001-471	Capacitor Ceramic 470pf 50V 10% Axial Lead
C27	12-10001-471	Capacitor Ceramic 470pf 50V 10% Axial Lead
C28	12-10001-471	Capacitor Ceramic 470pf 50V 10% Axial Lead
C30	12-10001-471	Capacitor Ceramic 470pf 50V 10% Axial Lead
C31	12-10001-471	Capacitor Ceramic 470pf 50V 10% Axial Lead
C32	12-10001-471	Capacitor Ceramic 470pf 50V 10% Axial Lead
C33	12-10002-104	Capacitor Ceramic .1uf 50V Axial Lead
C34	12-10002-104	Capacitor Ceramic .1uf 50V Axial Lead
C35	12-10002-104	Capacitor Ceramic .1uf 50V Axial Lead
C36	12-10002-104	Capacitor Ceramic .1uf 50V Axial Lead

FIGURE 9

SYM	TAITO PART NO.	DESCRIPTION
C37	12-10002-104	Capacitor Ceramic .1uf 50V Axial Lead
C38	12-10002-104	Capacitor Ceramic .1uf 50V Axial Lead
C39	12-10001-123	Capacitor Ceramic .012 50V Axial Lead
C40	12-10001-183	Capacitor Ceramic .018 50V Axial Lead
C41	12-10004-103	Capacitor Ceramic .01uf 50V Axial Lead
C42	12-10002-104	Capacitor Ceramic .1uf 50V Axial Lead
C43	12-10001-153	Capacitor Ceramic .015uf 50V Axial Lead
C44	12-10001-105	Capacitor Ceramic .1uf 50V Axial Lead
C45	12-10003-100	Capacitor 10pf NPO Axial Lead
C46	12-10002-104	Capacitor Ceramic .1uf 50V Axial Lead
C47	12-20001-105	Capacitor Electrolytic 1uf Axial Lead
C48	12-20001-105	Capacitor Electrolytic 1uf Axial Lead
C49	12-10001-471	Capacitor Ceramic 470uf 50V Axial Lead
C50	12-10001-471	Capacitor Ceramic 470pf 50V Axial Lead
C51	12-10002-104	Capacitor Ceramic .1uf 50V Axial Lead
C52	12-10002-104	Capacitor Ceramic .1uf 50V Axial Lead
C53	12-10002-104	Capacitor Ceramic .1uf 50V Axial Lead
C54	12-10002-104	Capacitor Ceramic .1uf 50V Axial Lead
C55	12-20001-105	Capacitor Electrolytic 1uf
C56	12-10002-104	Capacitor Ceramic .1uf 50V Axial Lead
C57	12-20001-477	Capacitor Electrolytic 470uf, 16V
C58	12-20001-477	Capacitor Electrolytic 470uf, 16V
C59	12-10002-104	Capacitor Ceramic .1uf 50V Axial Lead
C60	12-10002-104	Capacitor Ceramic .1uf 50V Axial Lead
C61	12-10001-471	Capacitor Ceramic 470pf 50V 10% Axial Lead
C62	12-10001-471	Capacitor Ceramic 470pf 50V 10% Axial Lead
C63	12-10001-471	Capacitor Ceramic 470pf 50V 10% Axial Lead
C64	12-10001-471	Capacitor Ceramic 470pf 50V 10% Axial Lead
C65	12-10001-471	Capacitor Ceramic 470pf 50V 10% Axial Lead
C66	12-10001-471	Capacitor Ceramic 470pf 50V 10% Axial Lead
C67	12-10001-471	Capacitor Ceramic 470pf 50V 10% Axial Lead
C68	12-10002-104	Capacitor Ceramic .1uf 50V Axial Lead
C69	12-10002-104	Capacitor Ceramic .1uf 50V Axial Lead
C70	12-10002-104	Capacitor Ceramic .1uf 50V Axial Lead
C71	12-10002-104	Capacitor Ceramic .1uf 50V Axial Lead
C72	12-10003-101	Capacitor 100pf 10% NPO Axial Lead
C73	12-10003-221	Capacitor 220pf 10% NPO Axial Lead
C74	12-10002-104	Capacitor Ceramic .1uf 50V Axial Lead
C75	12-20001-105	Capacitor Electrolytic 1uf
C76	12-20001-105	Capacitor Electrolytic 1uf
C77	12-10002-104	Capacitor Ceramic .1uf 50V Axial Lead
C78	12-10002-104	Capacitor Ceramic .1uf 50V Axial Lead
C79	12-10002-104	Capacitor Ceramic .1uf 50V Axial Lead
C80	12-10001-471	Capacitor Ceramic 470pf 50V 10% Axial Lead
C81	12-10001-471	Capacitor Ceramic 470pf 50V 10% Axial Lead
C83	12-30001-106	Capacitor Tant, 10uf, 16V
TP1	59-00021-001	Test Point
TP2	59-00021-001	Test Point

SYM	TAITO PART NO.	DESCRIPTION
TP3	59-00021-001	Test Point
TP4	59-00021-001	Test Point
TP5	59-00021-001	Test Point
TP6	59-00021-001	Test Point
TP7	59-00021-001	Test Point
TP8	59-00021-001	Test Point
TP9	59-00021-001	Test Point
TP10	59-00021-001	Test Point
TP11	59-00021-001	Test Point
RP1	11-50001-332	Resistor Sip Pack 3.3K
RP2	11-50001-332	Resistor Sip Pack 3.3K
RP3	11-50001-471	Resistor Sip Pack 47K
RP4	11-50001-471	Resistor Sip Pack 47K
RP5	11-50001-103	Resistor Sip Pack 10K
RP6	11-50001-332	Resistor Sip Pack 3.3K
U1	15-20244-001	Octal Buffer (74LS244)
U2	15-00002-001	Microprocessor 68A09E
	26-00001-040	Socket 40P DIP-For 68A09E
U3	15-20244-001	Octal Buffer (74LS244)
U4	15-20244-001	Octal Buffer (74LS244)
U5	15-00007-001	Microprocessor 6802
	26-00001-040	Socket 40P DIP for 6802
U6	15-20244-001	Octal Buffer (74LS244)
U7	15-00004-002	Parallel I/O 6821
U8	15-00004-002	Parallel I/O 6821
U9	15-20245-001	BUS Transceiver, Octal (74LS245)
U10	15-20244-001	Octal Buffer (74LS244)
U11	15-20245-001	BUS Transceiver, Octal (74LS245)
U12	15-20244-001	Octal Buffer (74LS244)
U13	15-50001-001	Digital to Analog Converter 8 Bit (1408)
U14	15-20032-001	Quad 2-input or (74LS32)
U15	15-10003-001	RAM 1K x 4 NMOS Static (2114)
	26-00001-018	Socket 18P DIP for 2114
U16	15-10003-001	RAM 1K x 4 NMOS Static (2114)
	26-00001-018	Socket 18P DIP for 2114
U17	15-20138-001	Decoder 1 of 8 (74LS138)
U18	15-50003-001	Quad OP AMP LM324
U19	15-60004-001	Speech Synthesis TMS5200
	26-00001-028	Socket 28P DIP for TMS5200
U20	15-00004-001	Parallel I/O 68A21
U21	15-60002-001	Line Driver (MC1488)
U22	15-00005-002	Serial I/O 68A50
	26-00001-024	Socket 24P DIP for 68A50
U23	15-20004-001	Inverter, HEX (74LS04)
U24	15-44066-001	Quad Analog Multiplexer (4066)
U25	15-60001-001	Line Receiver (MC1489)
U26	15-20161-001	Counter 4-Bit Presettable (74LS161)
U27	15-20092-001	Counter Divide By Twelve (74LS92)
U28	15-44066-001	Quad Analog Multiplexer (4066)

DATA/SOUND PROCESSOR

FIGURE 9

YM	TAITO PART NO.	DESCRIPTION
29	15-50002-001	Audio Amplifier (2002)
	30-00001-001	Heatsink to 220
30	15-50002-001	Audio Amplifier (2002)
	30-00001-001	Heatsink to 220
W1	29-00001-001	Switch, DIP 4 Pole
1	19-00002-001	Crystal 7.3728 MHZ
11	14-23904-001	Transistor NPN, Silcon 2N3904
1	25-00002-004	Connector 14 PIN Locking
5	25-00001-001	Connector Header 50 PIN
6	25-00001-001	Connector Header 50 PIN
7	25-00002-005	Connector 5 PIN Locking
8	25-00002-005	Connector 5 PIN Locking
9	25-00003-001	Connector RS232

FIGURE 10

SYM	TAITO PART NO.	DESCRIPTION
FB42	17-00001-001	Ferrite Bead
FB43	17-00001-001	Ferrite Bead
FB44	17-00001-001	Ferrite Bead
FB45	17-00001-001	Ferrite Bead
FB46	17-00001-001	Ferrite Bead
FB47	17-00001-001	Ferrite Bead
FB48	17-00001-001	Ferrite Bead
FB49	17-00001-001	Ferrite Bead
FB50	17-00001-001	Ferrite Bead
FB51	17-00001-001	Ferrite Bead
FB52	17-00001-001	Ferrite Bead
FB53	17-00001-001	Ferrite Bead
D1	13-14001-001	Diode IN4001
D2	13-14001-001	Diode IN4001
D3	13-14001-001	Diode IN4001
D4	13-14001-001	Diode IN4001
D5	13-14001-001	Diode IN4001
D6	13-14001-001	Diode IN4001
D7	13-14001-001	Diode IN4001
D8	13-14001-001	Diode IN4001
D9	13-14001-001	Diode IN4001
D10	13-14001-001	Diode IN4001
D11	13-14001-001	Diode IN4001
D12	13-14001-001	Diode IN4001
Q1	14-00001-001	Transistor NPN Darlington TIP120
Q2	14-00001-001	Transistor NPN Darlington TIP120
Q3	14-00001-001	Transistor NPN Darlington TIP120
Q4	14-00001-001	Transistor NPN Darlington TIP120
Q5	14-00001-001	Transistor NPN Darlington TIP120
Q6	14-00001-001	Transistor NPN Darlington TIP120
Q7	14-00001-001	Transistor NPN Darlington TIP120
Q8	14-00001-001	Transistor NPN Darlington TIP120
Q9		Not Used
Q10	14-00001-001	Transistor NPN Darlington TIP120
Q11	14-00001-001	Transistor NPN Darlington TIP120
Q12	14-00001-001	Transistor NPN Darlington TIP120
U1	26-00002-016	ROM Select
	26-00001-014	Socket 14P Dip, for U1
U2	15-20138-001	Decoder 1 of 8 (138)
U3		Not Used
	26-00001-024	Socket 24 Pin Dip for U3
U4		Not Used
	26-00001-024	Socket 24 Pin Dip for U4
U5		E-PROM "KRAM"™
	26-00001-024	Socket 24 Pin Dip for U5

SYM	TAITO PART NO.	DESCRIPTION
U6		E-PROM "KRAM"™
	26-00001-024	Socket 24 Pin Dip for U6
U7		E-PROM "KRAM"™
	26-00001-024	Socket 24 Pin Dip for U7
U8		E-PROM "KRAM"™
	26-00001-024	Socket 24 Pin Dip for U8
U9		E-PROM "KRAM"™
	26-00001-024	Socket 24 Pin Dip for U9
U10		E-PROM "KRAM"™
	26-00001-024	Socket 24 Pin Dip for U10
U11	15-00004-001	Paralell I/O 68A21
U12		Not Used
	26-00001-024	Socket 24 Pin Dip for U12
U13		Not Used
	26-00001-024	Socket 24 Pin Dip for U13
U14		E-PROM "KRAM"™
	26-00001-024	Socket 24 Pin Dip for U14
U15		E-PROM "KRAM"™
	26-00001-024	Socket 24P Dip Used for E-PROM
U16		E-PROM "KRAM"™
	26-00001-024	Socket 24 Pin Dip for U16
U17		E-PROM "KRAM"™
	26-00001-024	Socket 24 Pin Dip for U17
U18		E-PROM "KRAM"™
	26-00001-024	Socket 24 Pin Dip for U18
U19		E-PROM "KRAM"™
	26-00001-024	Socket 24 Pin Dip for U19
U20	15-00004-001	Paralell I/O 68A21
U21	15-20138-001	Decoder 1 of 8 (138)
U22	26-00002-016	ROM Select
	26-00001-014	Socket 24P Dip for U22
U23	15-20004-001	Inverter, HEX (74LS04)
U24		Not Used
U25		Not Used
U26		Not Used
U27		E-PROM "KRAM"™
	26-00001-014	Socket 14P Dip for U27
U28	15-20138-001	Decoder 1 of 8 (138)
U29		ROM Select
	26-00001-014	Socket 14P Dip Used for ROM Select
U30	15-00004-001	Paralell I/O 6821
J3	25-00001-001	Connector Header 50PIN
J5	25-00001-001	Connector Header 50PIN
J6	25-00001-001	Connector Header 50PIN
J11	25-00002-014	Connector 14 Pin Header .156 Center
J15	25-00002-014	Connector 14 Pin Header .156 Center
J16	25-00002-014	Connector 14 Pin Header .156 Center
J17	25-000023-014	Connector 14 Pin Header .156 Center

SCHEMATIC

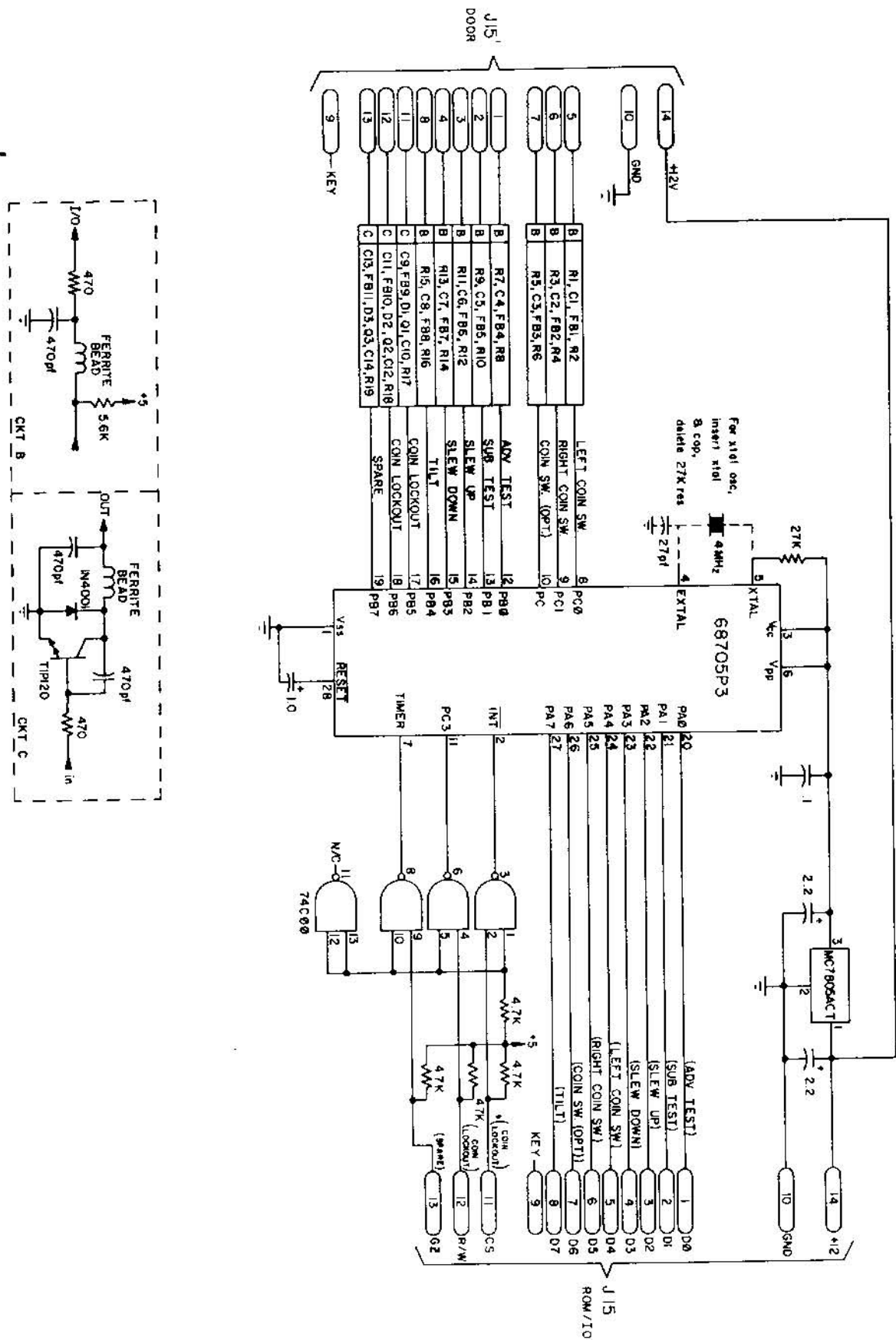

WIRING DIAGRAM
FIGURE 11

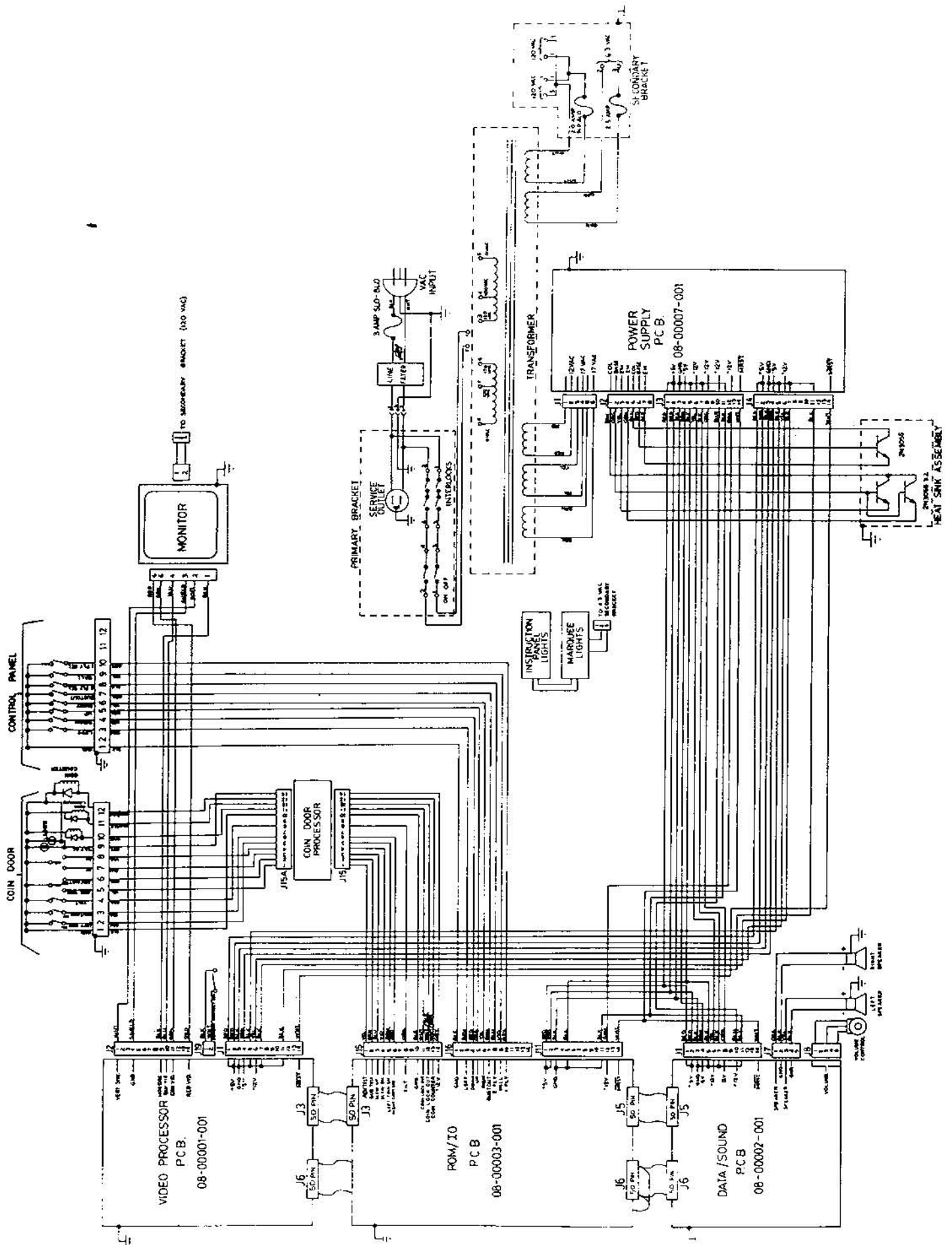

VIDEO PROCESSOR COMPONENT LAYOUT

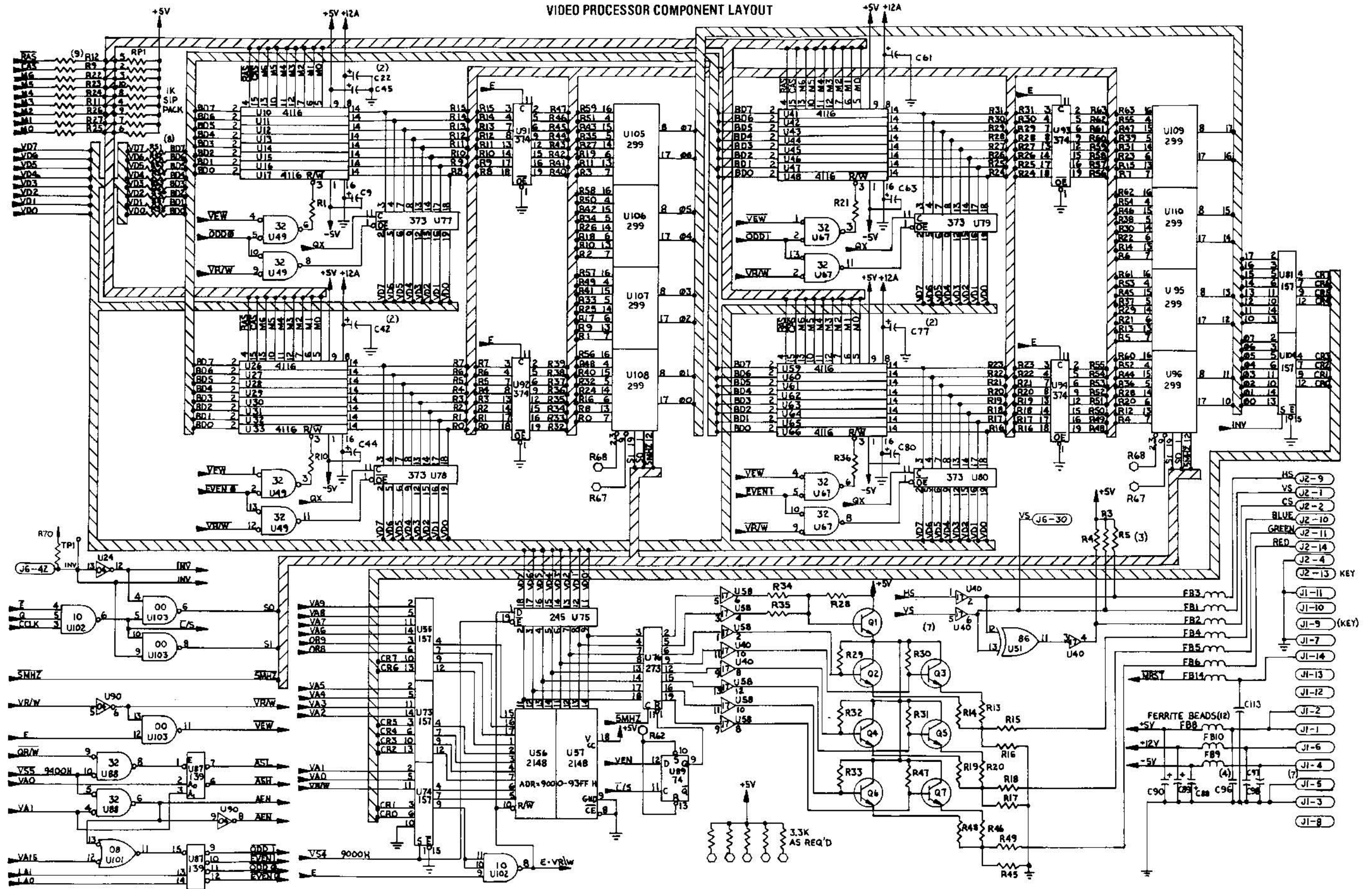

VIDEO PROCESSOR

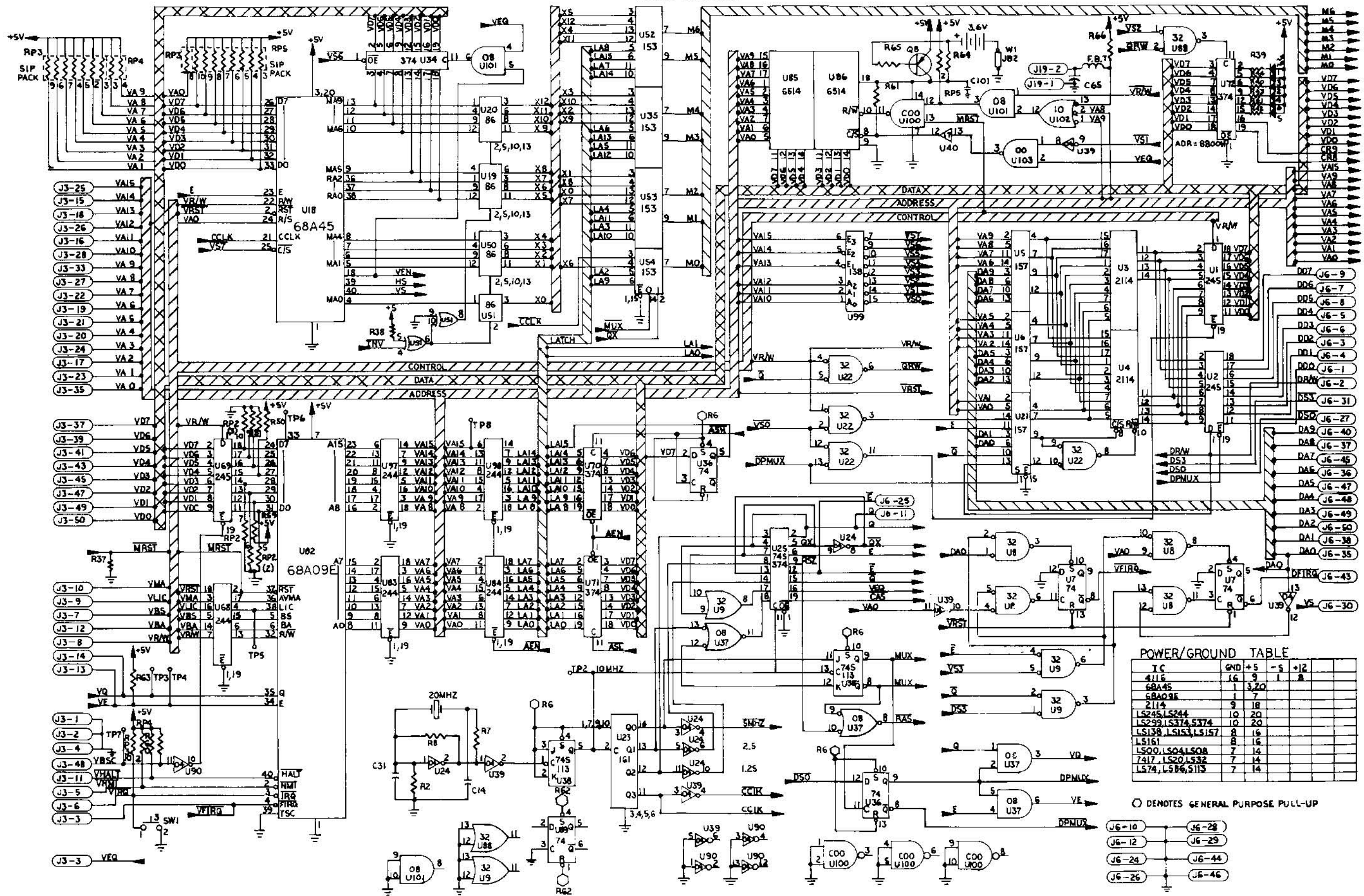

POWER/GROUND TABLE

IC	GND	+5	-5	+12
4116	16	9	1	8
68A45	1	3,20		
68A09E	1	7		
2114	9	18		
LS245,LS244	10	20		
LS299,LS374,LS374	10	20		
LS138,LS153,LS157	8	16		
LS161	8	16		
LS00,LS04,LS08	7	14		
7417,LS20,LS32	7	14		
LS74,LS86,LS113	7	14		

○ DENOTES GENERAL PURPOSE PULL-UP

- J6-10 J6-28
- J6-12 J6-29
- J6-24 J6-44
- J6-26 J6-46

ROM/I/O P.C. ASSEMBLY COMPONENT LAYOUT

MADE IN U.S.A.



08-00003-001

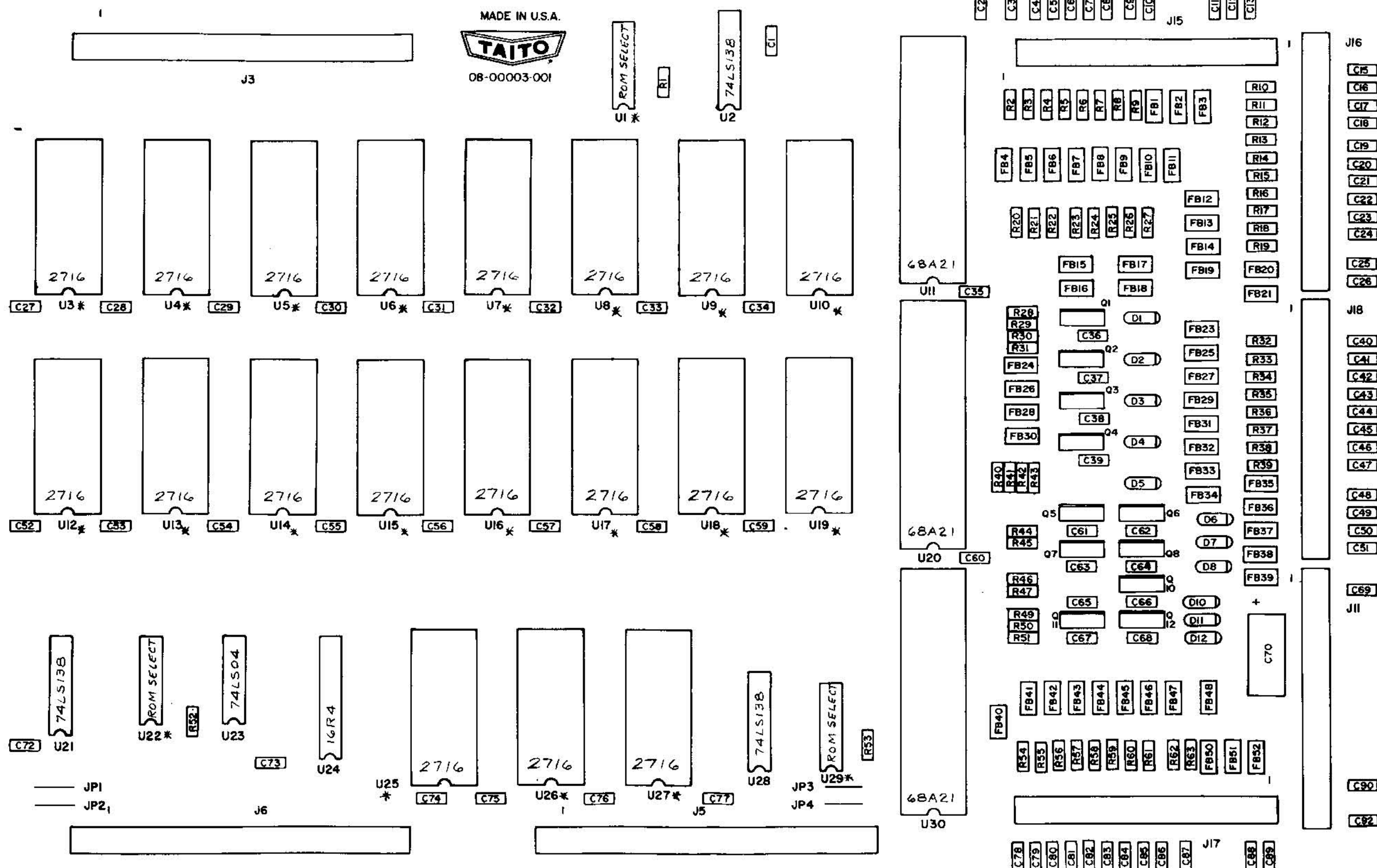

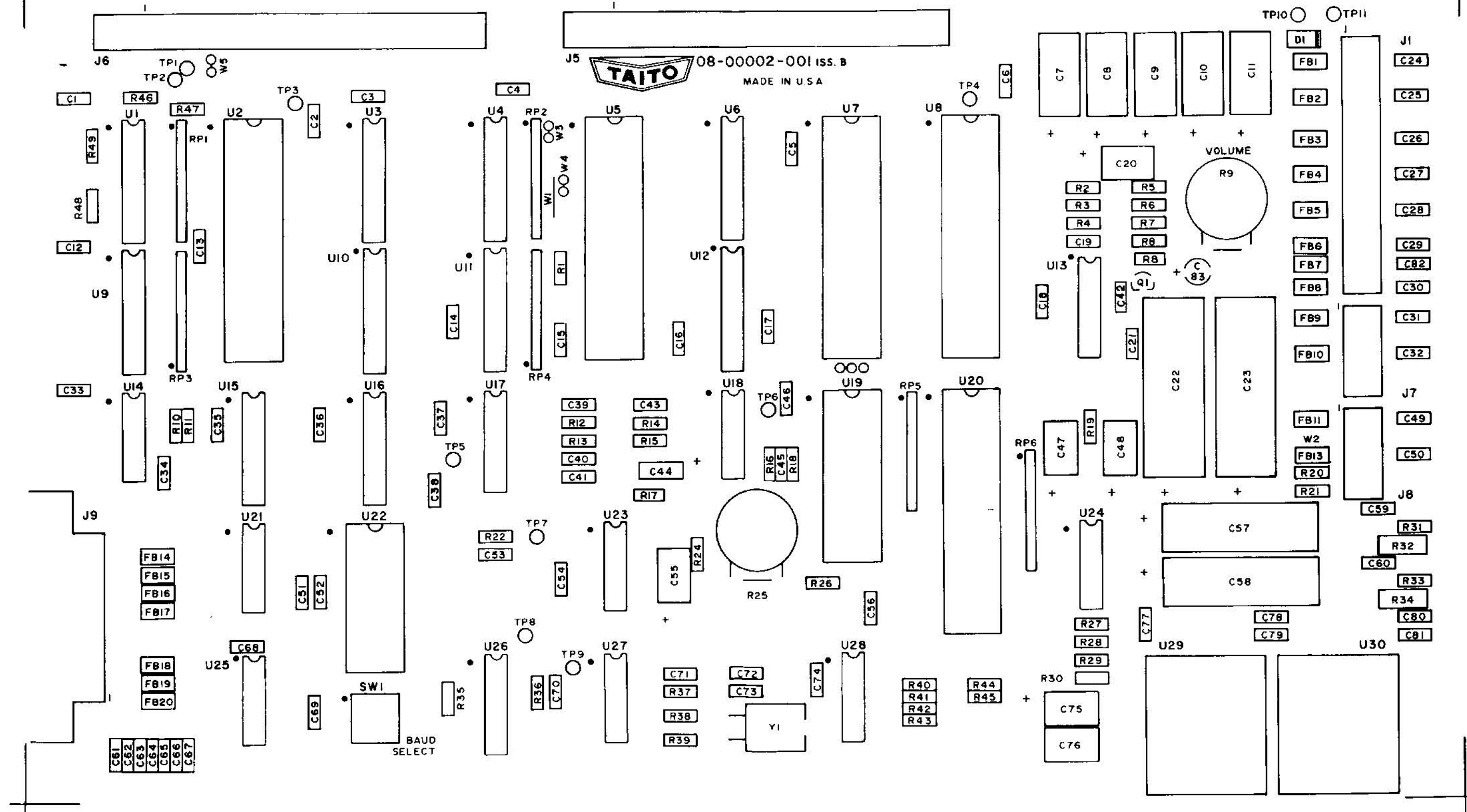

POWER SUPPLY SCHEMATIC

