

Bally/Midway's

LATARIAN

LICENSED FROM
ZACCARIA

Parts & Operating Manual



NO. 636 UPRIGHT

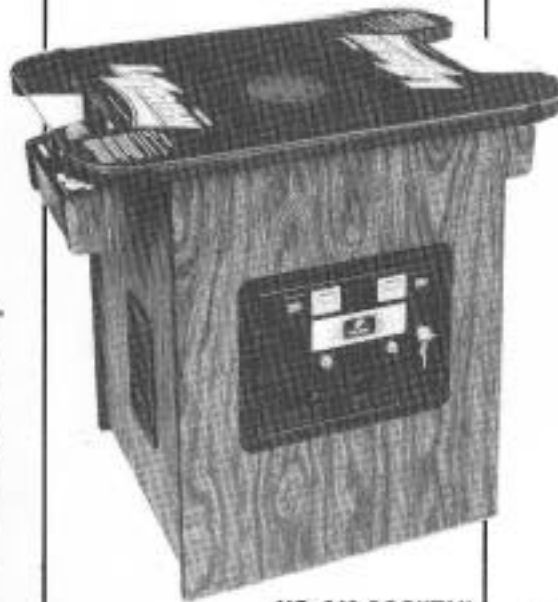

NO. 646 COCKTAIL



NO. 641 MINI

Bally

MIDWAY MFG. CO.

10750 W. Grand Avenue
Franklin Park, Illinois 60131
U.S.A.



Phone: (312) 451-1360

Cable Address: MIDCO

Telex No.: 72-1596

TABLE OF CONTENTS

DESCRIPTION	PAGE
I. Introduction	1-1
II. Location and Setup	
Inspection	2-1
Installation	2-1
Game Volume Adjustment Control	2-4
Option Switch Settings	2-4
III. Game Operation	
Calibration Mode	3-1
Attract Mode	3-1
Ready to Play Mode	3-1
Play Mode	3-1
Two Player Operation	3-3
IV. Maintenance and Repair	
Cleaning	4-1
Fuse Replacement	4-1
Opening the Control Panel	4-2
Removal of the Main Display Glass & T.V. Bezel	4-4
T.V. Monitor Replacement	4-5
Printed Circuit Board Replacement	4-8
Opening the Attraction Panel	4-10
V. Illustrated Parts Breakdown	
No. 636 — Lazarian Upright — Header Fluorescent Fixture Assy.	5-1
No. 636 — Lazarian Upright — Header Fluorescent Fixture Assy. — Parts List	5-1
No. 636 — Lazarian Upright — Front	5-2
No. 636 — Lazarian Upright — Front — Parts List	5-3
No. 636 — Lazarian Upright — Rear Access	5-4
No. 636 — Lazarian Upright — Rear Access — Parts List	5-5
No. 641 — Lazarian Mini — Front	5-6
No. 641 — Lazarian Mini — Front — Parts List	5-7
No. 641 — Lazarian Mini — Rear Access	5-8
No. 641 — Lazarian Mini — Rear Access — Parts List	5-9
No. 646 — Lazarian Cocktail — Front	5-10
No. 646 — Lazarian Cocktail — Front — Parts List	5-11
No. 646 — Lazarian Cocktail — Interior Access	5-12
No. 646 — Lazarian Cocktail — Interior Access — Parts List	5-13
Lazarian Transformer Board Assy. — All Versions — Parts List	5-15
Knob Control — All Versions	5-16
Knob Control — All Versions — Parts List	5-17
Front Door Assy. — U.S.A. 25¢	5-18
Front Door Assy. — U.S.A. 25¢ — Parts List	5-19

TABLE OF CONTENTS (cont'd)

DESCRIPTION	PAGE
VI. Technical Troubleshooting	6-1
Introduction	6-1
General Suggestions	6-1
Harness Component Troubleshooting	6-1
Transformer and Line Voltage Problems	6-2
A Glossary of Microprocessor Terms	6-3
Introduction to the Z80 CPU	6-3
General Purpose Registers	6-4
Arithmetic and Logic Unit (ALU)	6-4
Introduction Register and CPU Control	6-4
Z80 CPU Pin Description	6-4
VII. Coin Door Maintenance	7-1
Metal Coin Acceptor Mechanisms	7-1
Plastic Coin Acceptor Mechanisms	7-3
VIII. T.V. Monitor Manual	8-1
Introduction	8-1
Symptom Diagnosis	8-2
Guide to Schematic Symbols	8-3
Troubleshooting	8-5
Theory of Operation	8-6
IX. Schematics & Wiring Diagrams	
Wiring Diagram — Upright	9-1
Wiring Diagram — Mini	9-2
Wiring Diagram — Cocktail	9-3
Power Supply P.C.B. — Component Layout	9-4
Power Supply P.C.B. — Schematic	9-5
Game Board — Component Layout	9-6
Game Board — Schematic	9-7
Sound Board — Component Layout	9-8
Sound Board — Schematic	9-9
Monitor Interface P.C.B. — Component Layout	9-10
Monitor Interface P.C.B. — Schematic	9-11
Diode P.C.B. — Component Layout	9-12
Diode P.C.B. — Schematic	9-13
I.C. Functions	Inside Back Cover

TABLE OF FIGURES

FIGURE	PAGE
1-1 Assigned Point Values.....	1-2
2-1 Location of Serial No., Interlock Switch, On/Off Switch, & Major Sub-Assemblies	2-2
2-2 Major Sub-Assemblies (Cont. from Fig. 2-1)	2-3
2-3 Interlock Switch Operation	2-3
2-4 Game Volume Adjustment Control	2-4
2-5 Option Switch Locations	2-4
2-6 Option Switch Settings	2-5
4-1 Location of Fuses	4-1
4-2 Opening the Control Panel — Upright & Mini	4-2
4-3 Opening the Cocktail Game	4-3
4-4 Removing the Control Panel — Cocktail	4-3
4-5 Removing the Main Display Glass & T.V. Bezel — Upright	4-4
4-6 Removing the Main Display Glass & T.V. Bezel — Mini	4-4
4-7 Removing the Top Glass — Cocktail	4-5
4-8 Removing the Monitor — Upright	4-6
4-9 Removing the Monitor — Mini	4-6
4-10 Opening the Cocktail Game	4-7
4-11 Removing the Monitor — Cocktail	4-7
4-12 Replacing P.C.B.s — Upright.....	4-8
4-13 Replacing P.C.B.s — Mini.....	4-8
4-14 Replacing P.C.B.s — Cocktail	4-9
4-15 Opening the Attraction Panel — Upright	4-10
4-16 Replacing Fluorescent Tube Starter	4-11
4-17 Opening the Attraction Panel — Mini.....	4-11
7-1 Removing and Replacing the Coin Acceptor.....	7-1
7-2 Cleaning the Metal Coin Acceptor	7-2
7-3 Lubricating the Metal Coin Acceptor	7-2
7-4 Opening the Plastic Coin Acceptor.....	7-3
7-5 Changing the Plastic Coin Acceptor to Accept American or Canadian Quarters	7-4

Lazarian

IMPORTANT NOTE

DO NOT plug in your new game yet. Before you do anything to your game, we recommend that you read SECTIONS I and II of this manual completely. It will not take more than a few minutes and it may be very helpful.

I. Introduction

LAZARIAN is a one or a two player game. There are three models: the "UPRIGHT", "MINI", and "COCKTAIL TABLE". When the two player mode is selected on the Upright or Mini model, the players take turns at the controls to fly their space fighter(s) through the game course. If you have purchased the Cocktail Table model of this game, the rules of play are the same. The only **difference** is that in the two player mode of the Cocktail Table game, the picture flips to face you when it's your turn.

When playing this game, you are the pilot of a space fighter stationed in various places to rescue one of your stranded ships and to defend your sector of space against any and all types of hazards.

In the first phase of the first mission of game play, one of your sister ships is in trouble and sending out an SOS. It is completely surrounded by meteors which are held in a tight circle around it by separate interlocking force fields. Your task is to shoot the force fields as they turn yellow which causes them to release that particular meteor. You must release **ALL** the meteors **BEFORE** you will be able to rescue your sister ship.

After rescuing your sister ship, you must then avoid the meteorites coming at you and destroy all the

meteors circling around you **BEFORE** your fuel runs out. This will enable you to advance to the next phase of the first mission.

If you accomplished all of the above, your space ship is refueled and you are sent out on the second phase of your first mission — to rescue another ship which is in distress at the top left corner of your monitor's screen. To do this, you must face and surmount several different kinds of deadly obstacles while working your way through the four different levels of the tunnel. Again, you must do this **BEFORE** your fuel runs out.

When you have completed this latest rescue mission, your ship is refueled once more and you must face the one-eyed space leviathan in the third phase of your first mission. The only way to destroy it is by shooting its eye. This is not easy, to say the least. And again, you **MUST** do this **BEFORE** your fuel is exhausted.

As your skill level increases, and you advance farther and farther into the game, each successive mission becomes harder and harder to complete.

A bonus ship (this is switch selectable) may be awarded to you as you reach or pass a certain preselected point value. Each item which can be shot has an assigned point value as listed in Figure 1-1.

Major New Features

One new feature of your LAZARIAN game is the ability of your space ship to fire to the left, right, up, or down, giving you greatly increased fire power. Another new feature of your LAZARIAN game which will increase your ship's fire power to an even greater degree is the addition of optional switch selectable Laser Fire: Normal Manual Laser Fire (Laser fires as fast as you can press the FIRE buttons), and Auto-

matic Rapid Laser Fire (Laser fires at a high rate for as long as any of the FIRE buttons are held down).

Game Objective

The object of the game is to **HAVE FUN** and survive as long as possible while constantly improving your skills and destroying as many of the enemy as you can. As you do this, each successive mission will be harder to complete.

SCORING TABLE

FIRST PHASE OF EACH MISSION	
OBJECT	POINT VALUE
LIBERATED METEOR	VARIABLE — 10 TO 100 POINTS EACH
DESTROYED METEOR	VARIABLE — 10 TO 100 POINTS EACH
SECOND PHASE OF EACH MISSION	
OBJECT	POINT VALUE
ALIENS IN FIRST TUNNEL LEVEL	70 POINTS EACH
FORTS IN SECOND TUNNEL LEVEL	70 POINTS EACH
ALIENS IN THIRD TUNNEL LEVEL	70 POINTS EACH
DISTRESSED SISTER SHIP RESCUED	1000 POINTS
THIRD PHASE OF EACH MISSION	
OBJECT	POINT VALUE
PIECES OF LEVIATHAN	5 POINTS EACH
ALIENS IN THIS RACK	70 POINTS EACH
LEVIATHAN'S EYE RELEASED	1000 POINTS
1ST, 2ND, & 3RD LASER HITS ON EYE	500 POINTS EACH
4TH LASER HIT ON EYE (DESTROYS IT)	1000 POINTS

Figure 1-1 Assigned Point Values

II. Location and Setup

INSPECTION

1. Remove the game from its shipping crate.
2. Inspect the entire outside of it for any signs of damage.
 - Any scratches?, dents?, cracks?
 - Any broken controls?
 - Any broken glass or plastic?
 - Just look it over closely and make a note of any signs of damage.
3. Remove the shipping cleats from the bottom of the cabinet.
 - UPRIGHT MODELS ONLY: In order to help prevent easy theft of your game, you may wish to remove the Caster Wheel Assemblies from the bottom of your cabinet at this time.
4. Install the four levelers, one at each corner of the cabinet.
 - Level the cabinet.
5. Open the cabinet and inspect the inside of the game for any signs of damage. See Figure 2-1.
 - Also check to make sure all plug-in connectors on the wire harness are firmly seated.

NOTE: ALL connectors or plugs are keyed so they will only go together when all pins are properly lined up.

 - Replug any connectors found unplugged. DO NOT FORCE PLUGS ONTO CONNECTORS. DO NOT FORCE PLUGS TOGETHER. If it won't go on easily, assuming the keys are lined up, it either does not belong there or is damaged.
 - Make sure all printed circuit boards (P.C.B.'s) are firmly seated in their connectors. See Figure 2-1. These connectors are also keyed. The P.C.B.'s will only go into them one way without being damaged.
 - Note the location of the game's serial number. See Figure 2-1.
 - Check all major subassemblies to be sure they are mounted securely. These are called out in Figures 2-1 & 2-2.
 - Power supply.
 - Control panel(s).
 - T.V. monitor.
 - Other P.C.B.'s and/or P.C.B. rack, etc.
 - Power supply filter assembly.
 - Transformer board assembly.
6. Make a note of any problems that can't be easily corrected.
7. Call your distributor and/or service man about your problem list.

INSTALLATION

1. Location requirements:

- Power:**
 - Domestic 110 V @ 60 Hz
 - Foreign 200 V to 240 V @ 50 Hz
- Temperature:** 32° to 100° F (0° to 38° C)
- Humidity:** Not over 95% relative
- Space required:**
 - Upright 29" x 25" (73cm x 63cm)
 - Mini 20" x 24" (50cm x 60cm)
 - Cocktail 32" x 22" (81cm x 55cm)
- Game height:**
 - Upright 68" (170cm)
 - Mini 61" (153cm)
 - Cocktail 29" (73cm)

2. Voltage Selection:

Your game is designed to work properly on the line voltage where you are located. Check your line voltage with a meter to determine what its value is. Then check the power input wires to the main power supply transformer on your game to be sure they are connected to taps which correspond to your line voltage value.

If the power input wires to the main power supply transformer are not connected to taps which correspond to your local line voltage, move them to the proper taps.

If the line voltage in your area falls outside the upper or lower limits of the range of inputs covered by the main power supply transformer, **DO NOT PLUG YOUR GAME IN** until you have talked with your distributor and/or service man and obtained a solution to this problem. Otherwise you could damage your game.

3. Interlock and power ON/OFF switches. See Figure 2-1.

- To help prevent the possibility of getting an electric shock while working inside the game cabinet, interlock switches have been installed at each cabinet access door (this **DOES NOT** include the coin door in the Upright and Mini models).
- When any access door is opened, the interlock switch installed there turns off all power to the game.
- Check each interlock switch for proper operation.

After checking the line voltage in your area and determining that the input wires to the main power supply transformer of your game are connected properly — or — after obtaining a solution to your over or under voltage problem from your distributor and/or your service man, plug the game into your A.C. wall outlet.

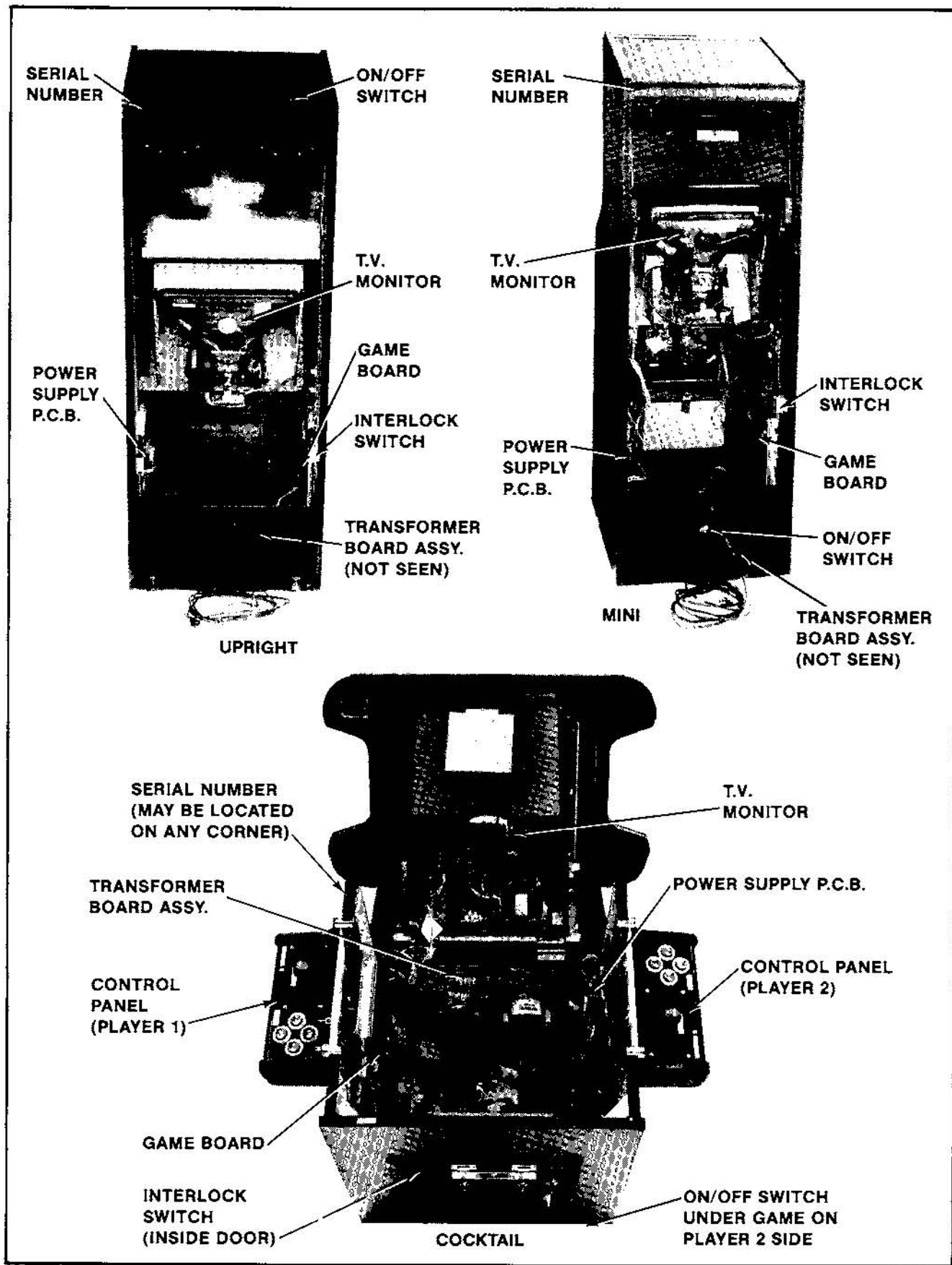

Figure 2-1 Location of Serial No., Interlock Switch, On/Off Switch & Major Sub-Assys.

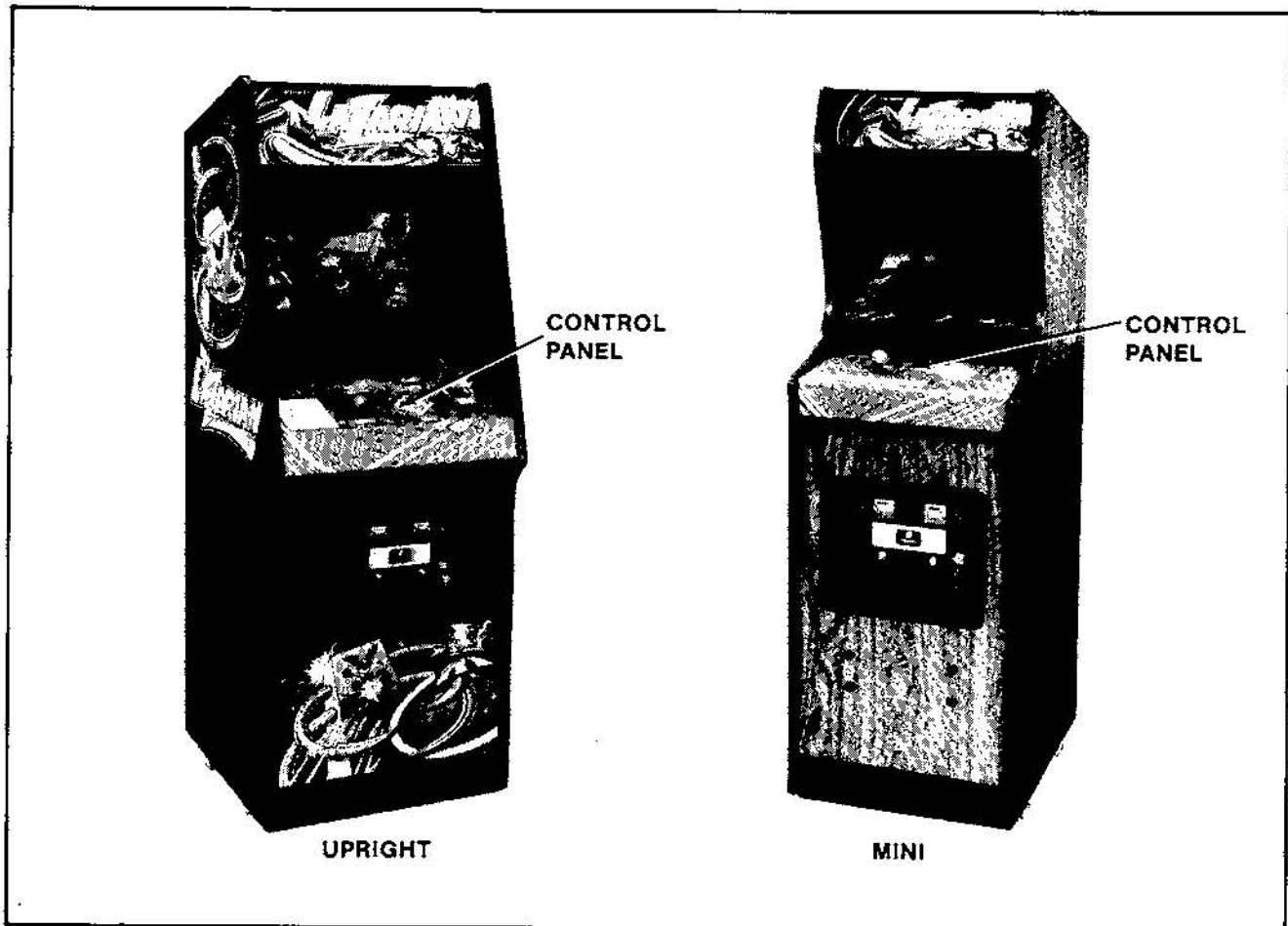

Figure 2-2 Major Sub-Assys. (cont. from Fig. 2-1)

The game ON/OFF switches for all models are located as shown in Figure 2-1. Turn the game on and allow it to warm up a few minutes.

Slowly open each access door to the game (this **does not** include the coin door on the Upright and Mini models).

As the door is opened approximately 1" (2.54cm) the power to the game should go off (the T.V. monitor, all the lights, and all sounds will stop).

If this does not happen, check the interlock switch by this door to see if it has broken loose from its mounting or if it is stuck in the "ON" position.

If the switch is found to be bad, turn the game off, unplug it, and replace the interlock switch. When done, plug the game back into the wall outlet, close the access door, and turn the game back on.

After the game has warmed up, repeat the above interlock switch test.

When the interlock switch is working properly and turns the power to the game off, power may be restored to the game with the access door(s) open. Take hold of the interlock switch plunger

and **gently** pull it out to its fully extended position. **THIS IS TO BE USED ONLY FOR SERVICING THE GAME.** See Figure 2-3.

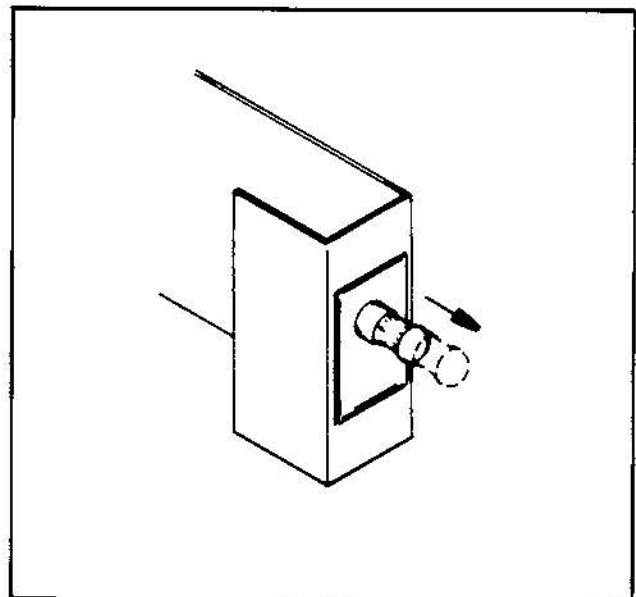

Figure 2-3 Interlock Switch Operation

GAME VOLUME ADJUSTMENT CONTROL.

See Figure 2-4. The volume control pot is located on the Sound board. This is a somewhat smaller P.C. Board than the main game P.C. Board. It may be reached through the coin door on the UPRIGHT models and through the rear access door on the MINI models. On the COCKTAIL TABLE models, you will have to open the table top to reach it.

To make the sounds louder, turn the pot clockwise as you face it (↻).

To make the sounds **less** loud, turn the pot counter-clockwise as you face it (↺).

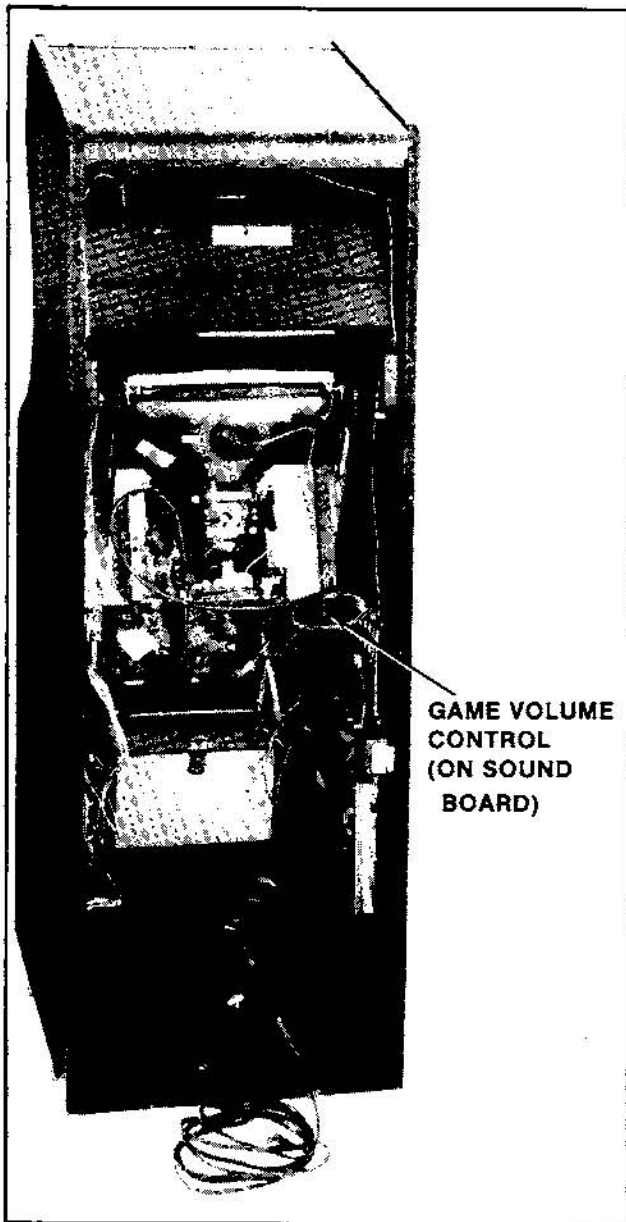

Figure 2-4 Game Volume Adjustment Control

OPTION SWITCH SETTINGS

To change the option switch settings, you DO NOT have to take the CPU board out of the game. They can be easily reached through the rear access door on the Upright and Mini models. On the Cocktail Table model, you do have to open the table top to reach them.

When changing any options, ALWAYS check the results by playing the game to be sure the switches have worked properly and that no switches were accidentally moved that were not meant to be. (These switches are small and this can happen.)

The option switch settings and what they will make the game do are shown in Figure 2-6. See Figure 2-5 for option switch locations.

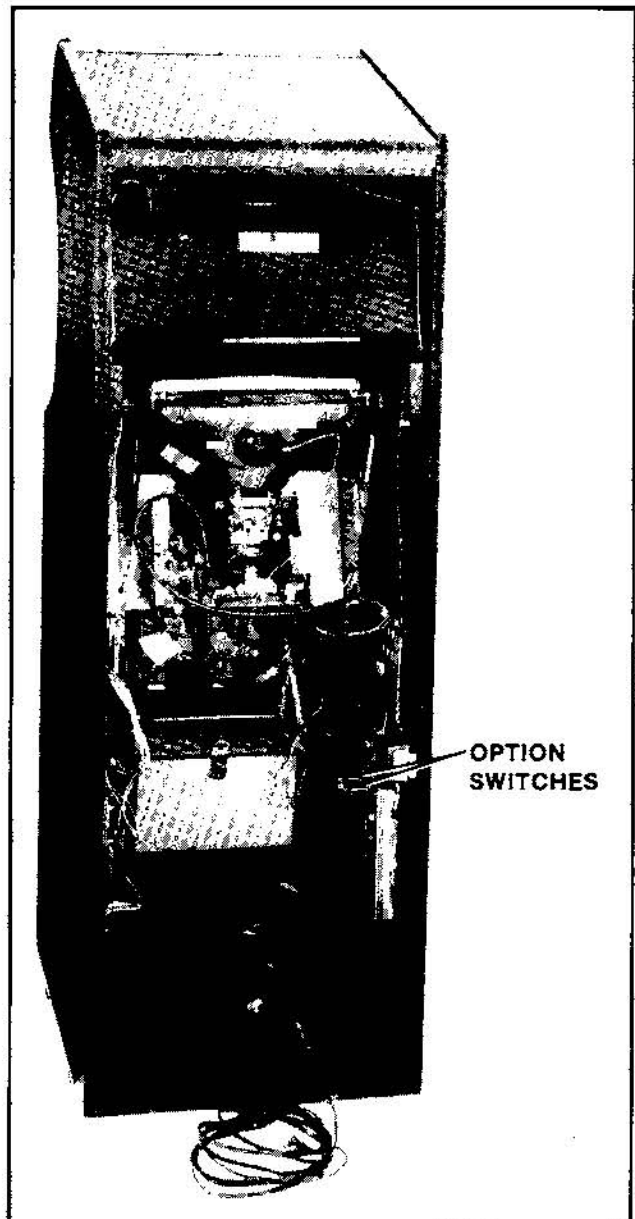

Figure 2-5 Option Switch Locations

LAZARIAN
OPTION SWITCH SETTINGS

DIP SWITCH SW-1	
<p style="text-align: center;">COINS PER PLAY</p> <p>2 COINS 1 PLAY *1 COIN 1 PLAY 1 COIN 2 PLAYS 1 COIN 3 PLAYS</p>	<p style="text-align: center;">SW#1 SW#2 SW#3 SW#4 SW#5 SW#6 SW#7 SW#8</p> <p>ON ON NOT NOT OFF ON USED USED ON OFF ON OFF</p>
<p style="text-align: center;">NUMBER OF SHIPS PER PLAY</p> <p>2 SHIPS *3 SHIPS 4 SHIPS 5 SHIPS</p>	<p style="text-align: center;">SW#1 SW#2 SW#3 SW#4 SW#5 SW#6 SW#7 SW#8</p> <p>ON ON OFF ON ON OFF OFF OFF</p>
SERVICE	
<p>*CALIBRATION GRID NOT DISPLAYED CALIBRATION GRID DISPLAYED</p> <p>"TEST" COLLISION DETECTION DISABLE **"GAME" COLLISION DETECTION NORMAL</p>	<p style="text-align: center;">SW#1 SW#2 SW#3 SW#4 SW#5 SW#6 SW#7 SW#8</p> <p>ON OFF</p> <p>ON OFF</p>
DIP SWITCH SW-2	
<p style="text-align: center;">LASER FIRING CONTROL</p> <p>NORMAL FIRE *RAPID FIRE</p>	<p style="text-align: center;">SW#1 SW#2 SW#3 SW#4 SW#5 SW#6 SW#7 SW#8</p> <p>NOT ON USED OFF</p>
<p style="text-align: center;">MONITOR CONTROL</p> <p>* NORMAL OPERATION FREEZE THE PICTURE</p>	<p style="text-align: center;">SW#1 SW#2 SW#3 SW#4 SW#5 SW#6 SW#7 SW#8</p> <p>ON OFF</p>
<p style="text-align: center;">DIFFICULTY LEVEL</p> <p>EASY GAME *MEDIUM GAME DIFFICULT GAME VERY DIFFICULT GAME</p>	<p style="text-align: center;">SW#1 SW#2 SW#3 SW#4 SW#5 SW#6 SW#7 SW#8</p> <p>ON ON OFF ON ON OFF OFF OFF</p>
<p style="text-align: center;">BONUS SHIPS AWARDED AT:</p> <p>NO BONUS SHIP AWARDED 10,000 POINTS — ONE SHIP ONLY *14,000 POINTS — ONE SHIP ONLY 18,000 POINTS — ONE SHIP ONLY</p>	<p style="text-align: center;">SW#1 SW#2 SW#3 SW#4 SW#5 SW#6 SW#7 SW#8</p> <p>ON ON OFF ON ON OFF OFF OFF</p>

*INDICATES FACTORY RECOMMENDED SETTINGS.

PART NO. M051-00636-A011

Figure 2-6 Option Switch Settings

III. Game Operation

LAZARIAN is a one or a two player game with a color T.V. monitor.

The game has five possible modes of operation: ATTRACT, READY-TO-PLAY, PLAY, HIGH SCORE/INITIAL, and SELF-TEST.

CALIBRATION MODE

To put the game into its CALIBRATION MODE the game MUST be "ON". Then slide **SW#7** of SWITCH PACK SW-1 to the "OFF" position (on UPRIGHT and MINI models, this Switch can be reached through the rear access doors — on COCKTAIL TABLE models, you will have to open the table top to reach it). At this time the game will display a GRID PATTERN on the monitor screen. This may be used for making any one of the number of adjustments to the game.

This GRID PATTERN will remain on the monitor screen until the above **SW#7** of SWITCH PACK SW-1 is returned to the "ON" position.

ATTRACT MODE

1. The Attract mode starts:

- Just after power has been turned on to the game.
- After a play has been finished, the score was not high enough to put the game into the High Score/Initial mode, and there are no more credits left in the game's memory.
- After the High Score/Initial mode when there are no more credits left in its memory.
- The next display in the series lists the five highest scoring individuals that have played the game to date.

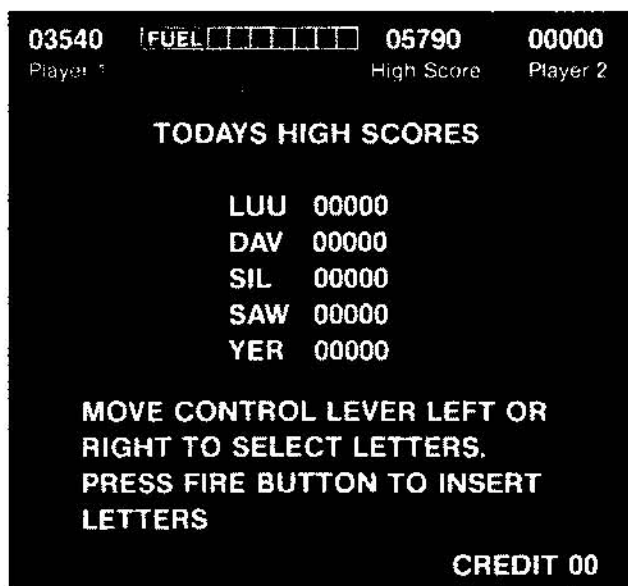

- When a game(s) has been paid for, the only difference in the game display is that the first display of the Attract Mode changes to that shown below:

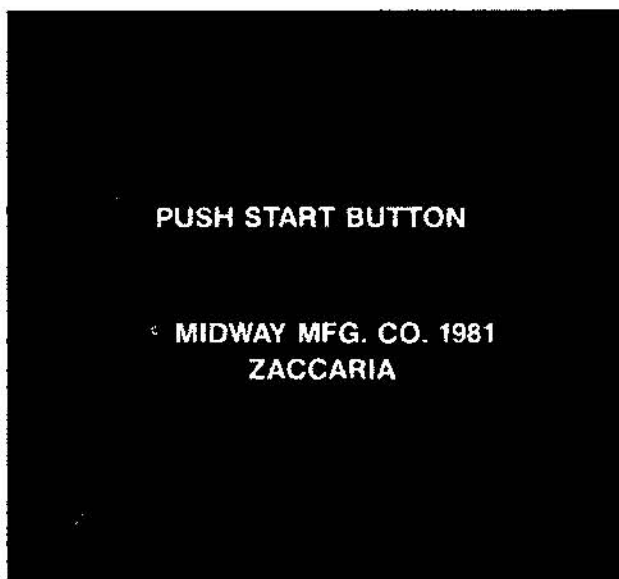

READY-TO-PLAY MODE

1. The Ready-To-Play mode starts when enough coins have been accepted for a 1 or a 2 player game.
2. The Ready-To-Play mode ends when either the "1 PLAYER" or the "2 PLAYER" push button is pressed.
3. In the Ready-To-Play mode, the game will give the above display in place of the first display of the Attract mode.
4. If no START button is pressed, the game will continue to run its Attract mode sequence of displays with the modified first display as shown above.

PLAY MODE

1. The Play mode begins when either the "1 PLAYER" or the "2 PLAYER" start button is pressed.
2. The Play mode ends when all of your space ships have been destroyed. When this happens, "GAME OVER" is written across the center of the monitor screen.
3. The game is made up of individual missions with three repeating phases each: two distressed space ships which it is your task to rescue (each rescue being more difficult than the one before) and a space leviathan (monster) which you must destroy. This sequence repeats throughout the

game. However, each time you go through it, it will be more difficult to complete than the last time you went through it.

The increased level of difficulty is accomplished by such means as shortening the range of your lazer and speeding up the timing of events within each phase of a mission. For instance, the period of time that any force field will stay yellow in the first phase of a mission is shortened.

After you complete each phase of the mission, your space ship moves to the point on the screen where it has to be to begin the next phase of the mission.

4. In the first phase of the first mission of game play, one of your sister ships is in trouble and sending out an SOS. It is completely surrounded by meteors which are held in a tight circle around it by separate interlocking force fields. Your task is to shoot the force fields as they turn yellow which causes them to release that particular meteor. You must release **ALL** the meteors **BEFORE** you will be able to rescue your sister ship. When the last meteor is released, your space ship is given another full load of fuel for completion of the rescue.

After rescuing your sister ship, you must then avoid the meteorites coming at you and destroy all the meteors circling around you **BEFORE** your fuel runs out. This will enable you to advance to the next phase of the first mission.

If you accomplished all of the above, your space ship is refueled and you are sent out on the second phase of your first mission — to rescue another ship which is in distress at the top left corner of your monitor's screen. To do this, you must face and surmount several different kinds of deadly obstacles while working your way through the four different levels of the tunnel. Again, you must do this **BEFORE** your fuel runs out.

When you have completed this latest rescue mission, your ship is refueled once more and you must face the one-eyed space leviathan in the third phase of your first mission. The only way to destroy it is by shooting its eye. This is not easy, to say the least. Because when your lazer first touches the leviathan's eye, it escapes from the dying monster. The escaped eye then moves about the monitor's screen in varying patterns and must be hit four times by your lazer before it will explode and die. Your space ship is also **NOT** given another full load of fuel upon the escape of the eye from the dying leviathan so you have **LESS** fuel to complete the mission and kill the eye. And again, you **MUST** do this **BEFORE** your fuel is completely exhausted in order to be able to advance to the next mission.

After completing the third phase of any mission — destroying the leviathan's eye, the screen is cleared, "GO FOR NEXT MISSION" is displayed

centered on monitor screen, the screen is then cleared again.

As your skill level increases, and you advance farther and farther into the game, each successive mission becomes harder and harder to complete.

When your **last** space ship is destroyed, the words "GAME OVER" are displayed **centered** on the monitor screen. (AT THIS POINT, SEVERAL DIFFERENT THINGS CAN HAPPEN DEPENDING ON WHAT YOUR SCORE WAS AND WHETHER OR NOT THERE ARE CREDITS STILL REMAINING IN THE GAME'S MEMORY.)

If you are still in the 1st MISSION when your **last** space ship was destroyed, the game will give you the opportunity to continue the game from the point where you lost this **last** space ship by displaying the following message on the screen.



PLAYER MAY CONTINUE GAME
BY INSERTING COIN WITHIN
10 SECONDS

This option is not offered by the game if your **last** space ship is lost in any MISSION beyond the 1st. If you lose your last space ship in a MISSION beyond the 1st, you must start your next game at the beginning of the 1st MISSION again.

If your score was high enough to be one of the five best scores, the game will go into the High Score/Initial mode immediately. If your score is not high enough to cause the game to go into the High Score/Initial mode, it will either go to the Attract mode (if there are no more credits left in its memory) or into the Ready-To-Play mode (if there are still credits left in its memory).

HIGH SCORE/INITIAL MODE:

In the High Score/Initial mode the game gives a display which looks like the following:

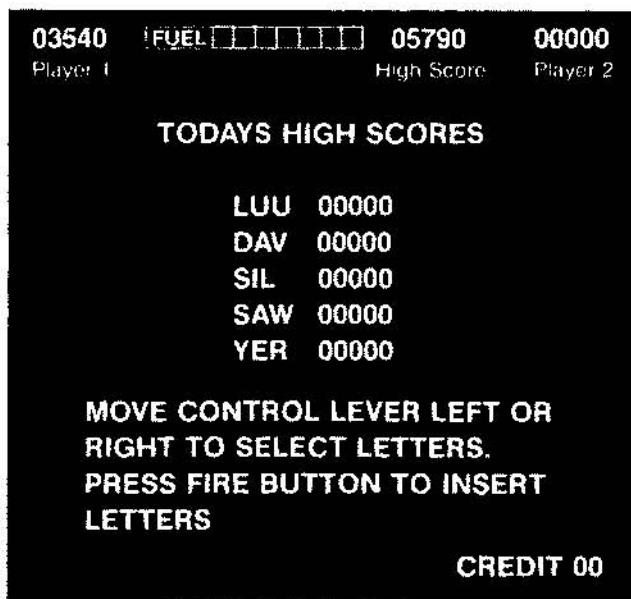

When in the High Score/Initial mode, YOUR SCORE has been positioned in its proper order among the other four high scores. The space at the left of your score is where you enter your initials. There will be an "A" in the first space and the other two spaces will be blank.

By moving the controller stick to the right, the letter can be made to sequence forward through the alphabet: "A", "B", "C", "D", etc. By moving the controller stick to the left, the letter can be made to sequence backward through the alphabet: "Z", "Y", "X", "W", etc.

When you reach your initial, release the controller and push any of the FIRE buttons. Your first initial is frozen in place and an "A" now appears in what was the blank space to the right of your first initial. You enter your second (and third) initial in the same manner as you did your first initial. If you do not wish to put your initials opposite your score, just press any of the FIRE buttons three times. Three "A"'s will appear opposite your score.

After the High Score/Initial mode, the game will either go to the Attract mode (if there are no more credits left in its memory) or into the Ready-To-Play mode (if there are still credits left in its memory).

Most of the above holds true in the "2 PLAYER" mode also. But there are a few minor differences.

TWO PLAYER OPERATION

The Upright, Mini, and Cocktail Table models all have two player operation.

In the two player mode, the rules of play are the same as in the single player mode. There are some additional rules however.

1. In the Upright and Mini models, the players must take turns at the controls.
2. In the Cocktail Table model, each player has his own set of individual controls. The picture will flip to face you when it is your turn. (When it is not your turn, your set of controls will have **NO** effect on the game.)
3. Your turn lasts until your space ship is destroyed. At this point, the game will do one of several things depending on whether or not the destroyed ship was your last or if you still have others remaining in reserve.

SPACE SHIP DESTROYED — OTHERS REMAINING IN RESERVE

- All movement stops.
- Next, the screen is cleared and the following display shown **centered** on the monitor screen:

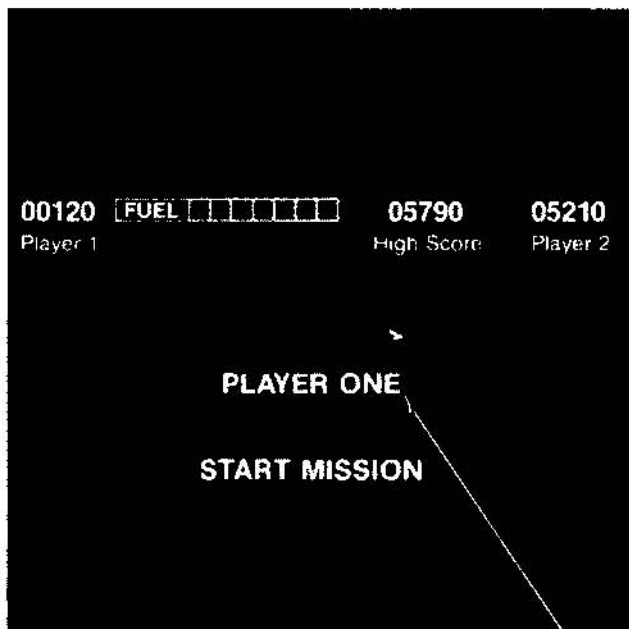

- The screen is cleared again and play begins for the other player.

**SPACE SHIP DESTROYED — NONE REMAINING
IN RESERVE**

- All movement stops and screen is cleared.
- Game displays "GAME OVER".
- Next, if your score was high enough to be one of the five best scores, the game will go into the High Score/Initial mode presentation immediately.
- After you have entered your initials, the screen is cleared and the following display shown **centered** on the monitor screen:



OR PLAYER TWO

- The screen is cleared again and play begins for the other player.
- If your score was not high enough to cause the game to go into the High Score/Initial mode, it will go right to the above display, the screen will be cleared, and play will begin for the other player.

IV. Maintenance and Repair

Your **NEW** game needs certain types of maintenance to keep it in good working order. **CLEAN**, well **MAINTAINED** games attract players and **EARN MORE PROFITS**.

The most important thing for you to remember is to play your game thoroughly **EVERY TIME** you collect money from the coin box. **JUST LOOKING** at your game **WILL NOT** tell you if all its controls and inside parts are working correctly. **ONLY** being familiar with and playing your game will inform you whether or not it is working the way it should.

The second most important thing you should remember is to clean the outside of the game and coin acceptor mechanisms on a regular basis.

CLEANING

The outside of the game cabinet plus the metal can be cleaned with any non-abrasive household cleaner. However, the front of the T.V. monitor tube and **both sides** of all other glass and plastic on or in the game **MUST** be cleaned with anti-static cleaner **ONLY**. For cleaning the coin acceptors: hot soapy water may be used on the plastic ones and any household cleanser may be used on the metal ones. If you wish, special coin machine cleaners that leave no residue may be purchased from your distributor.

DO NOT dry-wipe any of the plastic panels. This is because any dust that was on them can scratch their surfaces. If this has happened, anyone looking through this type of damaged plastic would feel he was looking at the game through a fog. This fogging

damage **CANNOT** be repaired or reversed. The **ONLY** solution is to **replace** the damaged piece of plastic.

FUSE REPLACEMENT

This game contains several fuses located as shown in Figure 4-1.

1. UPRIGHT MODEL:

As viewed from the back, facing the cabinet, with the rear access door removed; the fuses are located on the Transformer and the Power Supply Board Assemblies.

2. MINI MODEL:

As viewed from the back, facing the cabinet, with the rear access door removed; the fuses are located on the Transformer and the Power Supply Board Assemblies.

3. COCKTAIL TABLE MODEL:

As viewed from the coin door side of the cabinet, with the monitor tilted open to one side; the fuses are located on the Transformer and Power Supply Board Assemblies.

Replace fuses **ONLY** with the type and size listed in the Illustrated Parts Breakdown Section of this manual.

See the T.V. Monitor Manual (available on request from your Distributor or the Monitor manufacturer) and/or the T.V. Troubleshooting Section of this manual for information on these fuses.

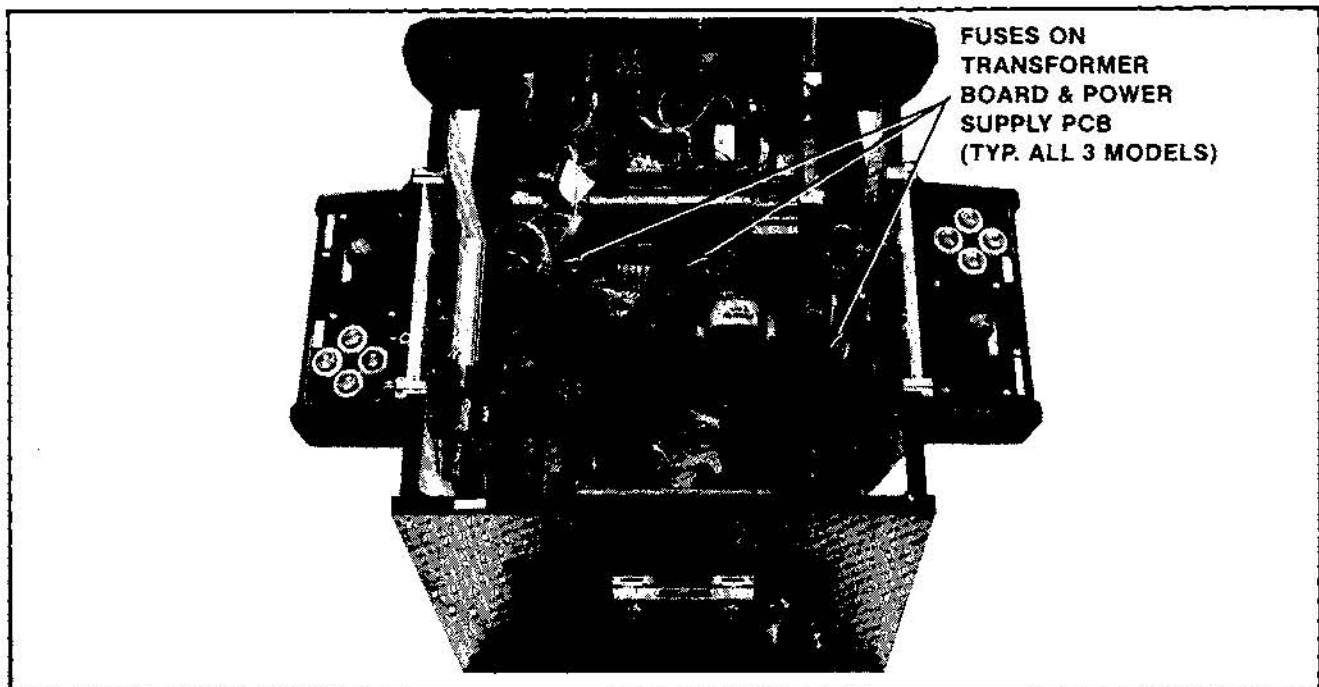

Figure 4-1 Location of Fuses

OPENING THE CONTROL PANEL. See Figure 4-2.

1. UPRIGHT MODEL:

- The control panel is held in place by three latches, one on the left side, one on the right side, and one on the front center. They are spring loaded to provide constant positive pressure on their latch plates. They can be reached through the coin door **AFTER turning power to the game off.** To release the latches, lift up and toward the front center of the control panel. Once they are released, unhook them from their latch plates.
- To remove the control panel: Raise it up and tilt it toward you until you can see the cable behind it. Cradling the control panel between yourself and the cabinet, disconnect it from its cabling. The control panel is now free and can be removed.
- To reinstall the control panel, reverse this procedure.

2. MINI MODEL:

- The control panel is held in place by two latches, one on the right side and one on the left side of the cabinet. They are spring loaded to provide constant positive pressure on their latch plates. They can be reached through the coin door **AFTER turning power to the game off.** To release the latches, lift up and toward the center of the control panel. Once they are released, unhook them from their latch plates.
- To remove the control panel: Raise it up and tilt it toward you until you can see the cable behind it. Cradling the control panel between yourself and the cabinet, disconnect it from its cabling. The control panel is now free and can be removed.
- To reinstall the control panel, reverse this procedure.

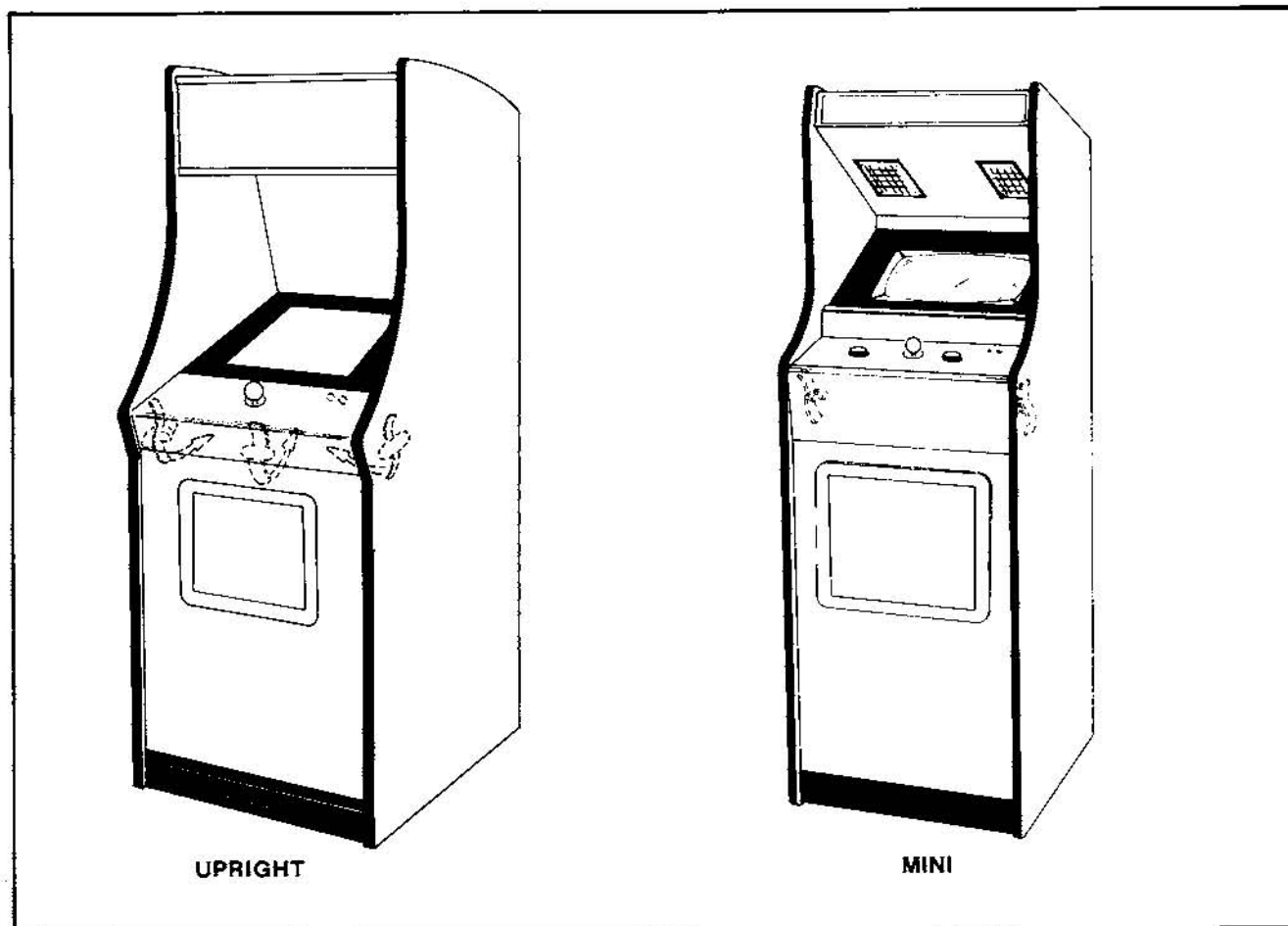

Figure 4-2 Opening the Control Panel — Upright & Mini

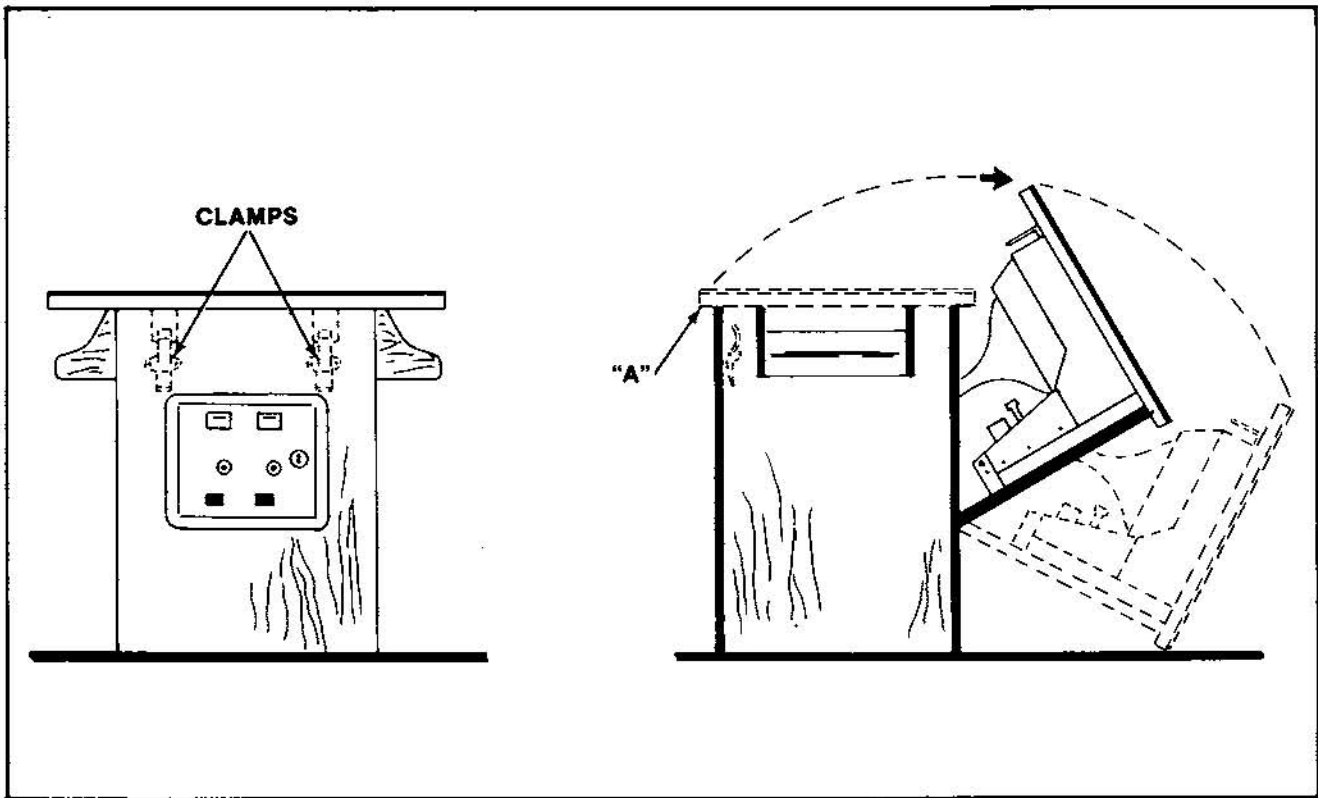

Figure 4-3 Opening the Cocktail Game

3. COCKTAIL TABLE MODEL:

- Each control panel is held in place by several screws, two on the inside of the cabinet and three along the outside bottom edge of the control panel.

Turn power to the game off.

Open the coin box door and release the two latches indicated in Figure 4-3.

CAUTION: The right hand latch is very close to the HIGH VOLTAGE on the monitor.

Once they're released, unhook them from their latch plates.

Grasp the table top at "A" and open it as indicated in Figure 4-3.

CAUTION: Due to the weight of the monitor, EXTREME CARE MUST be taken when opening the cabinet.

Remove the screws which secure the control panel in place. See Figure 4-4.

- To remove the control panel(s):
Disconnect it from its cabling.
The control panel is now free and can be removed.
- To reinstall the control panel, reverse this procedure.

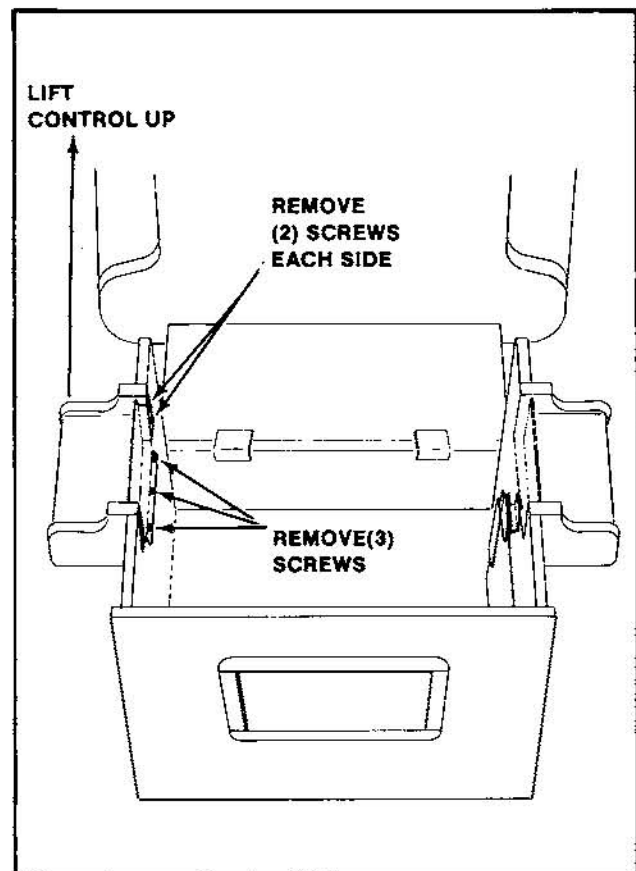

Figure 4-4 Removing the Control Panel — Cocktail

REMOVAL OF THE MAIN-DISPLAY-GLASS AND/OR THE T.V. BEZEL ASSEMBLY

1. UPRIGHT MODEL: See Figure 4-5.

NOTE: In order to do this, the control panel **MUST** be removed first. See the "Upright Model" procedure.

- Turn the power to the game off and remove the control panel. This frees the main-display-glass so it can be lifted up.
- By putting your finger in the hole in the middle of the main-display-glass support, you can lift it up and out.
- Loosen the screws which secure the T.V. bezel-glass-clamps in place. Move the clamps to the side and the bezel glass may be removed. Remove the above mentioned screws and the bezel with four bezel-glass-clamps may be removed.
- To reinstall the T.V. bezel assembly and the main-display-glass, reverse this procedure.

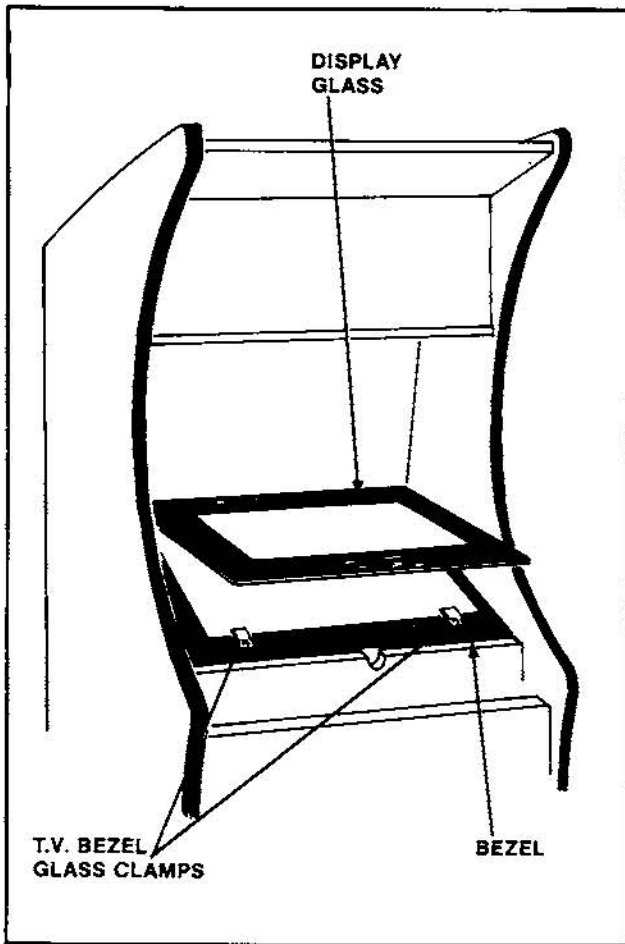

Figure 4-5 Removing Main Display Glass & T.V. Bezel
— Upright

2. MINI MODEL:

NOTE: In order to do this, the control panel **MUST** be removed first. See the "Mini Model" procedure.

- Turn the power off to the game and remove the control panel.
- Remove the screws which secure the glass clamping plate.
- Lift out the glass clamping plate. This frees the main-display-glass so it can be lifted up.
- By putting your finger in the hole in the middle of the main-display-glass support, you can lift it up and out.
- Remove the screws which secure the T.V. bezel assembly and lift it out.

NOTE: Use the hole in the center of the main-display-glass support to grasp it.

- Reverse this procedure to reinstall the T.V. bezel assembly and the main-display-glass.

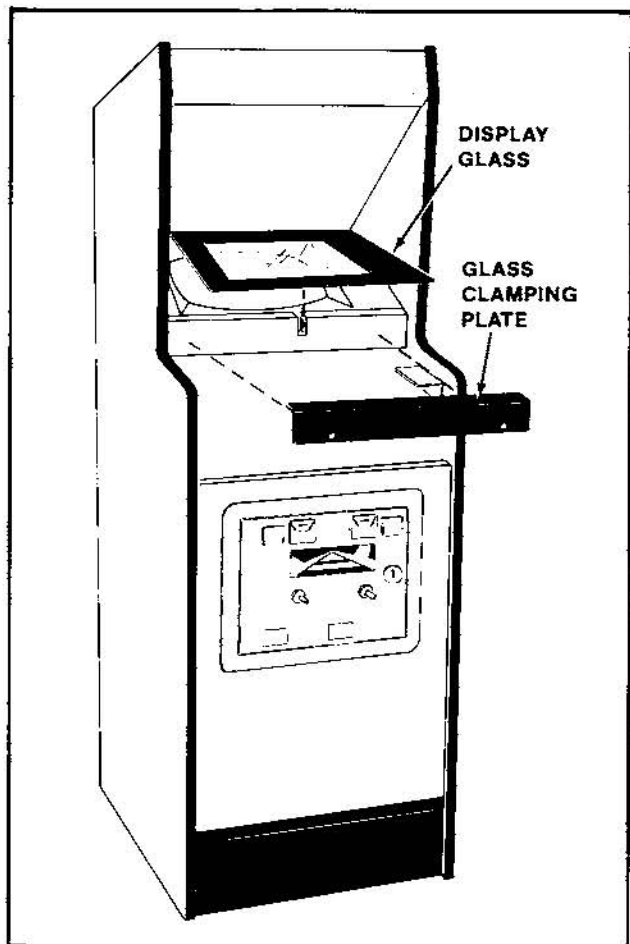

Figure 4-6 Removing Main Display Glass & T.V. Bezel
— Mini

3. COCKTAIL TABLE MODEL: See Figure 4-7.

NOTE: This may be done with the table top in the open or the closed position. If you decide to open the table top, **TURN THE POWER TO THE GAME OFF FIRST.**

- Remove the screws which secure the table top glass clamps in place.
- Remove the table top glass.
- Loosen the screws which secure the T.V. bezel-glass-clamps in place.
Move the clamps to the side and the bezel glass may be removed.
Remove the screws which secure the bezel assembly to the table top and the bezel with four bezel-glass-clamps may be removed.
- To reinstall the T.V. bezel assembly and the table top glass, simply reverse this procedure.

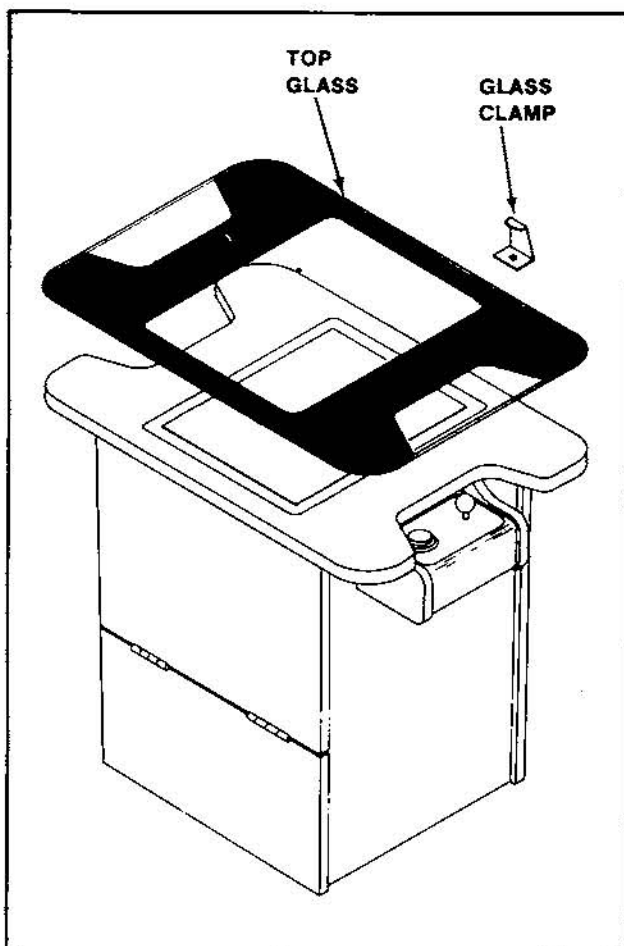

Figure 4-7 Removing Top Glass & T.V. Bezel
— Cocktail

T.V. MONITOR REPLACEMENT

CAUTION: High voltages may exist in any television unit, even with the power disconnected. Use **EXTREME CAUTION** and do not touch electrical parts or the T.V. yoke area with your hands or with metal objects held in your hands!

In addition, **BE SURE TO USE HEAVY GLOVES** when handling the monitor. You could cut your hands on the metal T.V. chassis without such protection.

DANGER: The T.V. monitor **DOES NOT** contain an isolation transformer on its chassis (it is mounted instead on the floor of the cabinet). When servicing the monitor on a test bench, **YOU MUST ISOLATE THE MONITOR FROM AC VOLTAGE WITH AN ISOLATION TRANSFORMER.**

1. UPRIGHT MODEL: See Figure 4-8.

- Turn power off to the game.
- Open the rear access door.
- Completely disconnect the T.V. monitor from all its cabling. **DON'T FORGET THE CHASSIS GROUND WIRE.**

Before removing the T.V. monitor, the main-display-glass and bezel **MUST** be removed. See above "Upright Model" procedure.

With the removal of only four bolts, the T.V. monitor and its mounting channels will be loose.

The monitor mounting channels slide on top of and against two metal guides mounted to the cabinet's right and left sides. The monitor is removed by sliding it out the back of the cabinet. See Figure 4-8.

- To reinstall the T.V. monitor, reverse this procedure.
- After replacing the T.V. monitor, be sure to run the game Self-Test.

2. MINI MODEL: See Figure 4-9.

- Turn the power off to the game.
- Open the rear access door.
- Completely disconnect the T.V. monitor from all its cabling. **DON'T FORGET THE CHASSIS GROUND WIRE.**

Before removing the T.V. monitor, the main-display-glass and bezel **MUST** be removed. See above "Mini Model" procedure.

With the removal of only four bolts, the T.V. monitor will be loose.

CAUTION: **BE SURE** to support the T.V. monitor from the rear while removing the four bolts so it will not fall out of the cabinet.

The monitor is removed by supporting it and pulling straight back as shown in Figure 4-9.

- To reinstall the T.V. monitor, reverse this procedure.

After replacing the T.V. monitor, be sure to run the game Self-Test.

3. COCKTAIL TABLE MODEL: See Figure 4-11.

- Turn the power off to the game.
- Open the coin box door and release the two latches indicated in Figure 4-10.

CAUTION: The right hand latch is very close to the **HIGH VOLTAGE** on the monitor.

- Once the latches are released, unhook them from their latch plates.
- Grasp the table top at "A" and open it as indicated in Figure 4-10.

CAUTION: due to the weight of the monitor, **EXTREME CARE MUST** be taken when opening the cabinet.

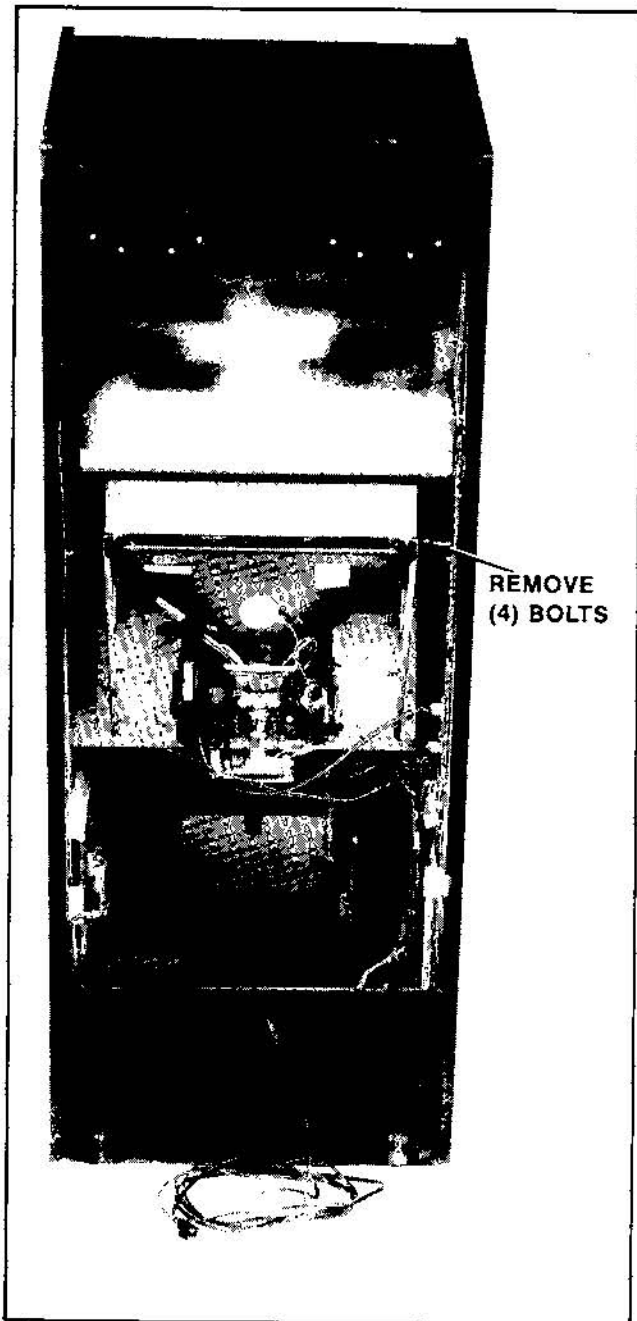

Figure 4-8 Removing Monitor — Upright

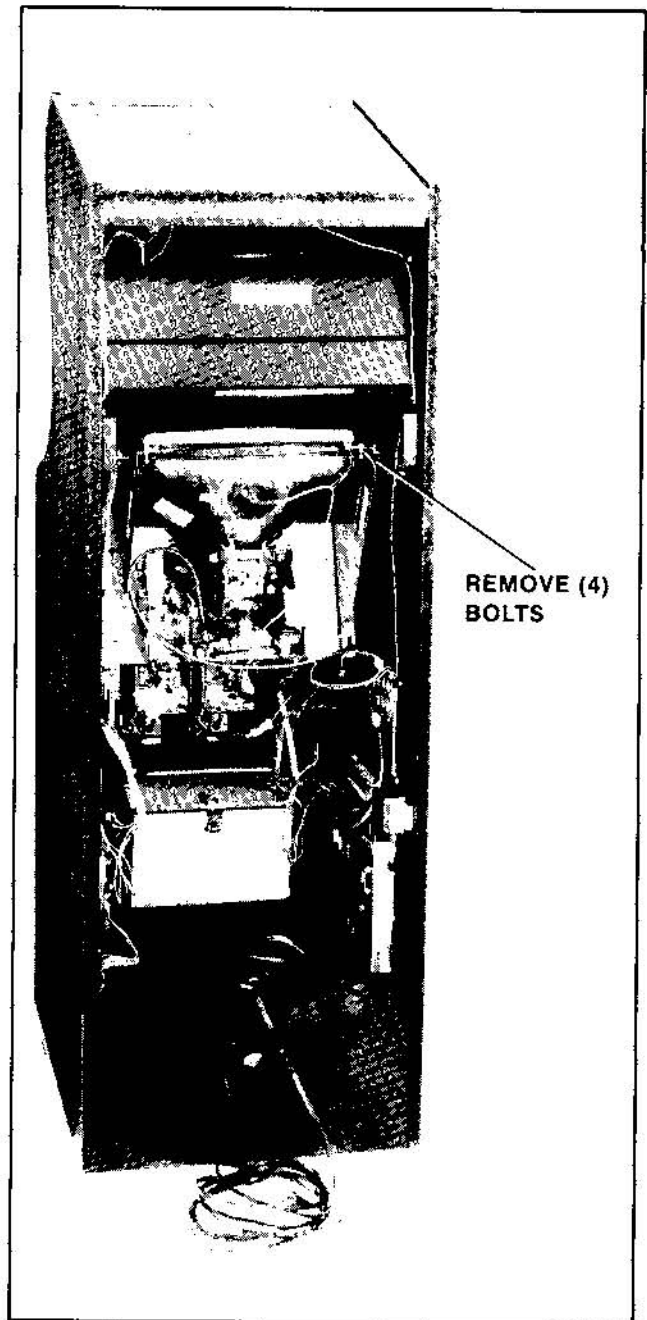

Figure 4-9 Removing Monitor — Mini

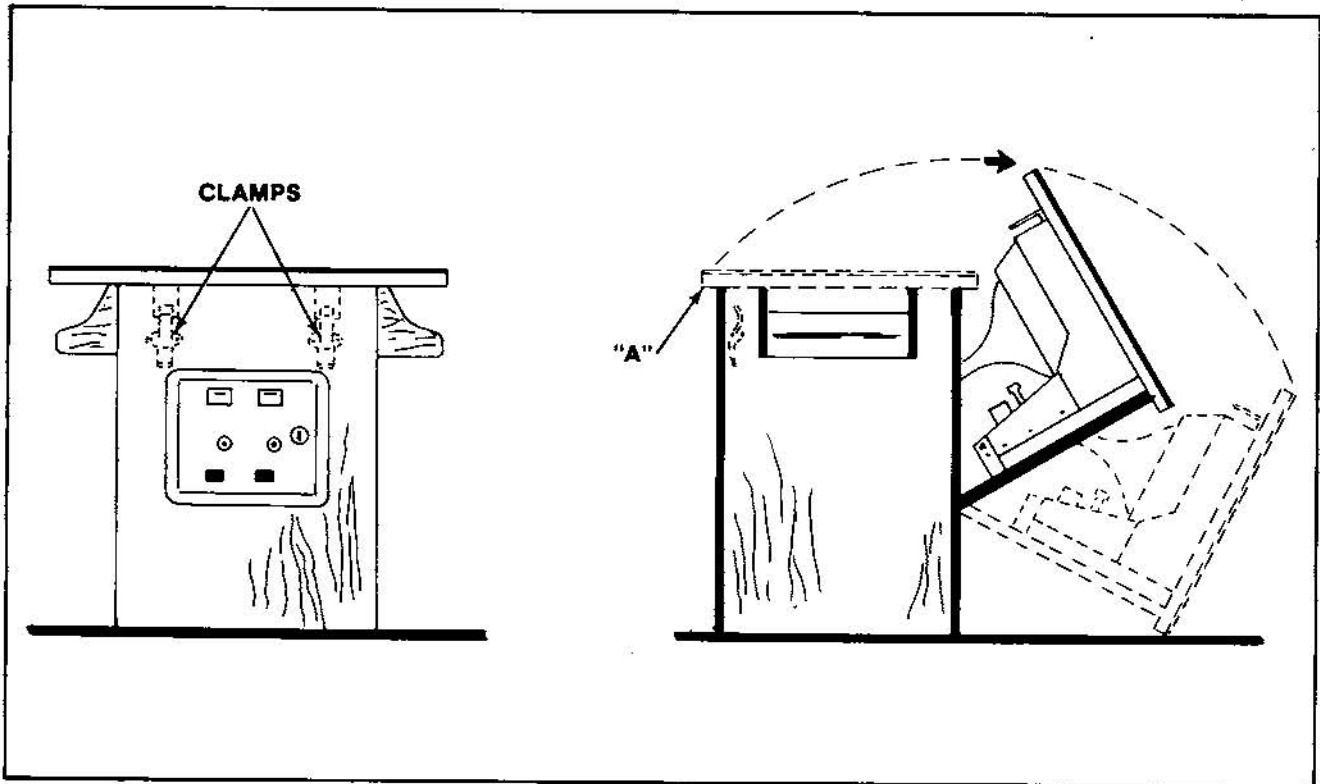

Figure 4-10 Opening the Cocktail Game

- Remove the screws which hold the table top glass clamps in place.
- Remove the table top glass.
- Lift out the T.V. bezel assembly.
- Completely disconnect the T.V. monitor from all its cabling. **DON'T FORGET THE CHASSIS GROUND WIRE.**
- Remove the screws holding the T.V. monitor chassis to the "L" by the door hinge(s). See Figure 4-11.
- Close the Cocktail Table and re-latch it.
- Remove the screws which secure the T.V. monitor mounting brackets to the edges of the slot cut in the table top. See Figure 4-11.
- Pry up the end of each monitor mounting bracket with a screwdriver or similar tool until you can grasp them both.
- Lift the T.V. monitor straight up and out of the table top being **VERY CAREFUL** not to bump the neck of the picture tube.
- To reinstall the T.V. monitor assembly, reverse this procedure.
- Be sure to check the clearance of the "L" brackets **BEFORE** setting the monitor into the table top.
- After replacing the T.V. monitor, be sure to run the game Self-Test.

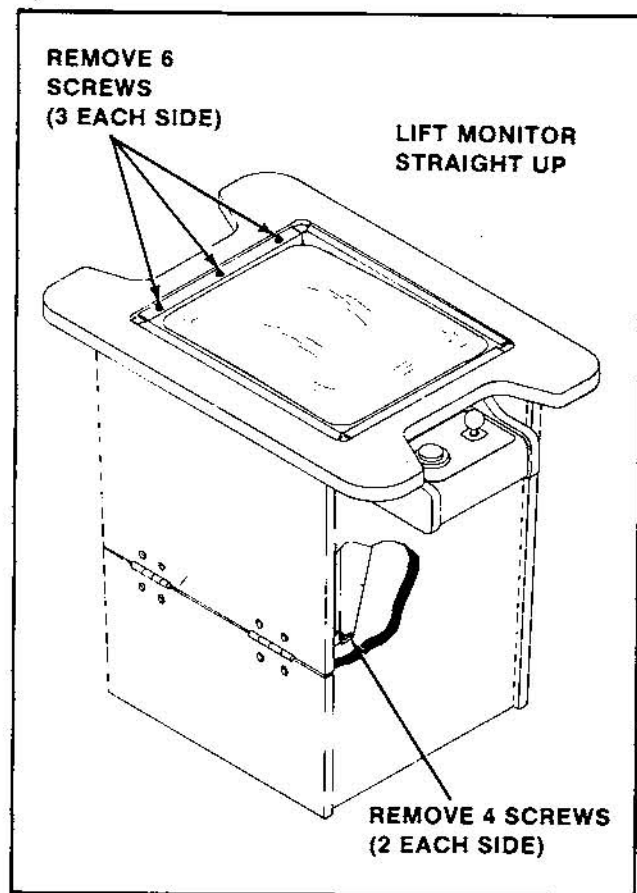

Figure 4-11 Removing Monitor — Cocktail

PRINTED CIRCUIT BOARD (P.C.B.) REPLACEMENT

1. UPRIGHT MODEL: See Figure 4-12.

- Turn the power to the game off.
- Unlock and open the rear access door (game board) and the coin door (sound board).
- Disconnect the game board from all its cabling.
- Disconnect the sound board from all its cabling.
- Remove the indicated P.C.B. supports and lift the above P.C.B.'s out the cabinet.

- Disconnect the power supply board from all its cabling, remove the P.C.B. supports indicated in Figure 4-12, and slide it out the back of the cabinet.
- To reinstall the above P.C.B.'s, reverse this procedure.

NOTE: P.C.B.'s are all keyed and will **ONLY** fit into their connectors one way without forcing them. The plugs on the cable harness which connect it to the P.C.B.'s are also keyed and will **ONLY** go onto their connectors one way without forcing them.

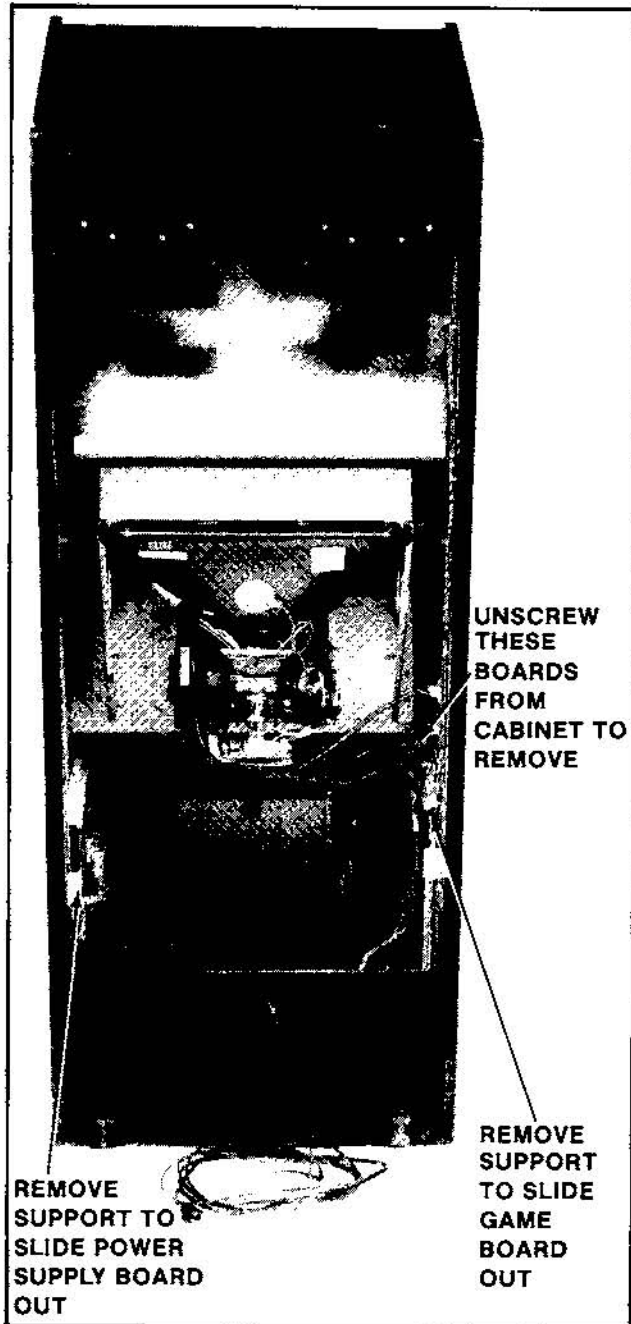

Figure 4-12 Removing P.C.B.s — Upright

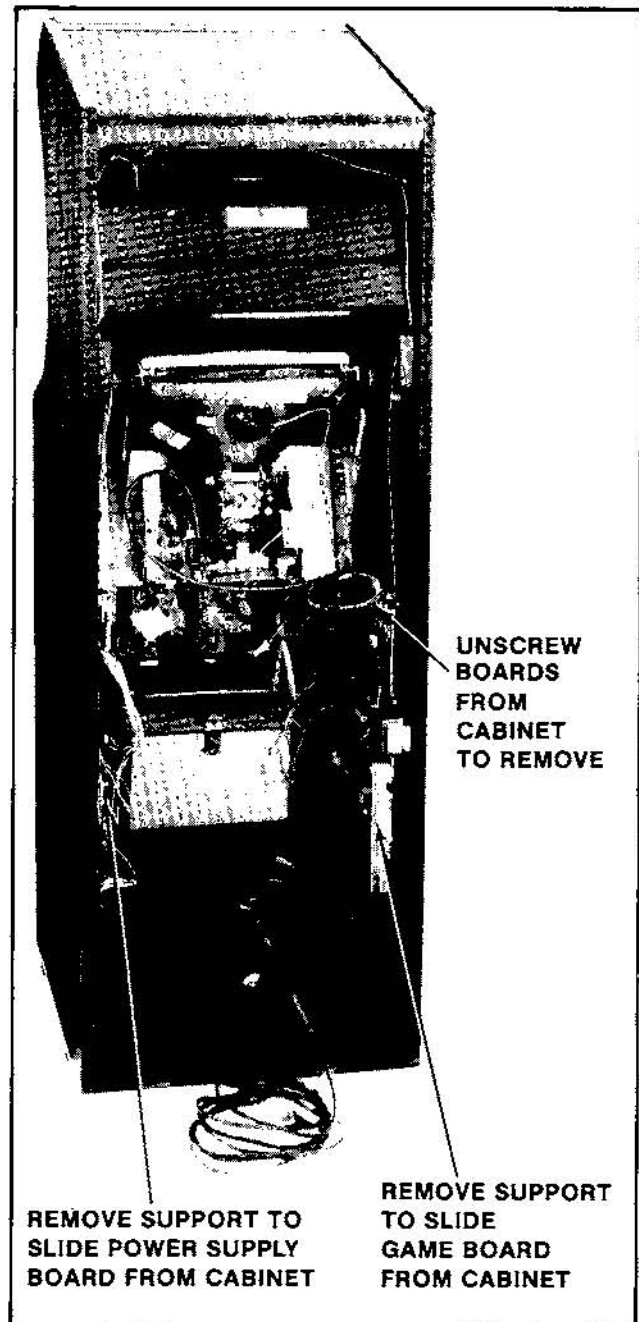

Figure 4-13 Removing P.C.B.s — Mini

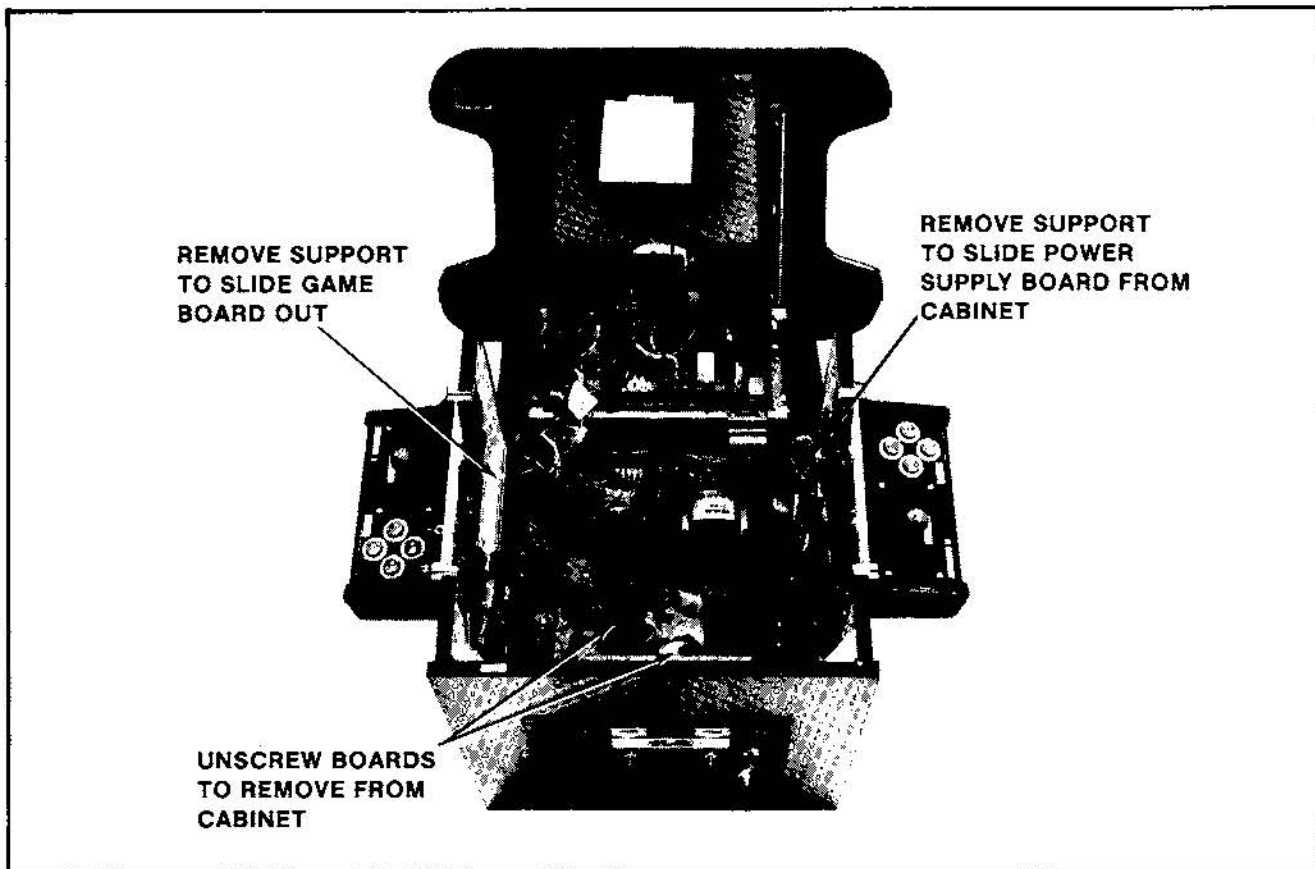

Figure 4-14 Removing P.C.B.s — Cocktail

2. MINI MODEL: See Figure 4-13.

- Turn the power off to the game.
- Unlock and open the rear access door.
- Disconnect the game board from all its cabling.
- Disconnect the sound board from all its cabling.
- Remove the indicated P.C.B. supports and lift the above P.C.B.'s out of the cabinet.
- Disconnect the power supply board from its cabling, remove the P.C.B. supports indicated in Figure 4-13, and slide it out the back of the cabinet.
- To reinstall the above P.C.B.'s, reverse this procedure.

3. COCKTAIL TABLE MODEL: See Figure 4-14.

- Turn the power off to the game.
- Open the cabinet:
Open the coin box door and release the two latches indicated in Figure 4-10.

CAUTION: The right hand latch is very close to the HIGH VOLTAGE on the monitor.

Once they're released, unhook them from their latch plates.

- Grasp the table top at "A" and open it as indicated in Figure 4-10.

CAUTION: Due to the weight of the monitor, EXTREME CARE MUST be taken when opening the cabinet.

- To remove the power supply board. See Figure 4-14.
Disconnect it from all its cabling.
Remove the two smallest P.C.B. supports.
Once these are removed, the power supply can be lifted out the top of the cabinet.
To reinstall the power supply board, reverse this procedure.
- To remove the game and Sound boards. See Figure 4-14.
Disconnect the game board from all its cabling.
Disconnect the sound board from all its cabling.
- Remove the indicated P.C.B. supports and lift the above P.C.B.'s out of the cabinet.
To reinstall the game and sound boards, reverse this procedure.

OPENING THE ATTRACTION PANEL:

1. UPRIGHT MODEL: See Figure 4-15.

- Turn the power to the game off.
- Opening the attraction panel:
 - Remove the screws which secure the top bracket in place. (They are on its top side.) See Figure 4-15.
 - Remove the top bracket and slide up the attraction panel. This exposes the attraction panel fluorescent light tube and its mounting bracket assembly.
 - To reinstall the attraction panel, reverse this procedure.
- The fluorescent light tube may be replaced at this time. BE CAREFUL NOT TO DROP IT.

WARNING: If you drop a fluorescent tube and it breaks, IT WILL IMplode! Shattered glass can fly six (6) feet or more from the implosion. Use care when replacing any fluorescent tube.

- Replacing the fluorescent light tube starter. See Figure 4-16.
 - Be sure the power to the game has been turned off.**
 - Grasp the starter (it is on the back of the mounting bracket), give it a quarter turn, and remove it from its socket.
 - To replace the fluorescent light tube starter, reverse this procedure.
- Replacement of the fluorescent tube mounting bracket assembly.
 - Be sure the power is off to the game.**
 - Disconnect it from its power cable.
 - Remove the screws which secure it and gently slide it out the front of the cabinet, being careful not to catch its power cable on anything.
 - To reinstall the fluorescent tube mounting bracket assembly, reverse this procedure.
- Replacing the speaker.
 - Be sure the power is off to the game.**
 - Remove the attraction panel and disconnect the speaker from its cabling.
 - Remove the nuts and bolts which secure the speaker and speaker grill in place and set them and the speaker grill aside.
 - Once the bolts which secure the speaker in place are removed, the speaker may be removed through the opening where the attraction panel was.
 - Reverse this procedure to reinstall the speaker.



Figure 4-15 Opening the Attraction Panel — Upright

2. MINI MODEL: See Figure 4-17.

- Turn the power off to the game.
- Remove the screws from the top and bottom of the formed attraction panel.
- Remove the formed attraction panel by pulling it straight away from the cabinet. This exposes the attraction panel light bulbs and their mounting board.

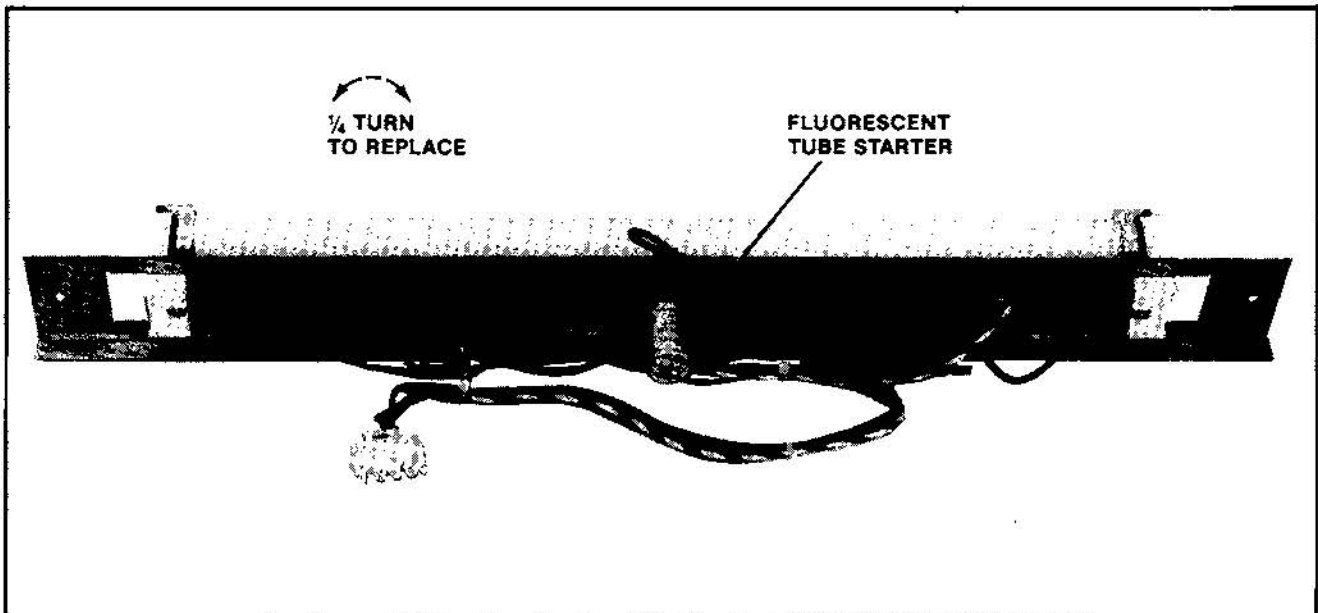

Figure 4-16 Replacing Fluorescent Tube Starter

- To service the light bulbs and their mounting board:

Turn the power to the game back on so you can see which bulbs are burnt out.

Mark the burnt out bulbs and **turn the power to the game back off again.**

To replace the burnt out bulbs, grasp them gently and pull straight out.

The new bulbs are gently pushed into the empty sockets.

To completely replace the light bulb mounting board:

Open the cabinet rear access door and unplug the mounting board from its power cable.

Remove the screws that hold the mounting board to the cabinet.

Gently slide the mounting board out the front of the cabinet being careful not to catch its cable on anything.

To reinstall the above removed items, reverse this procedure.

- To replace the speaker.

Be sure the power is off to the game.

Disconnect the speaker from its cabling.

Remove the nuts and bolts securing the speaker.

Slide the speaker out through the rear access door.

To reinstall the speaker, simply reverse this procedure.

3. THE COCKTAIL MODE HAS NO BACK-LIT ATTRACTION PANEL.

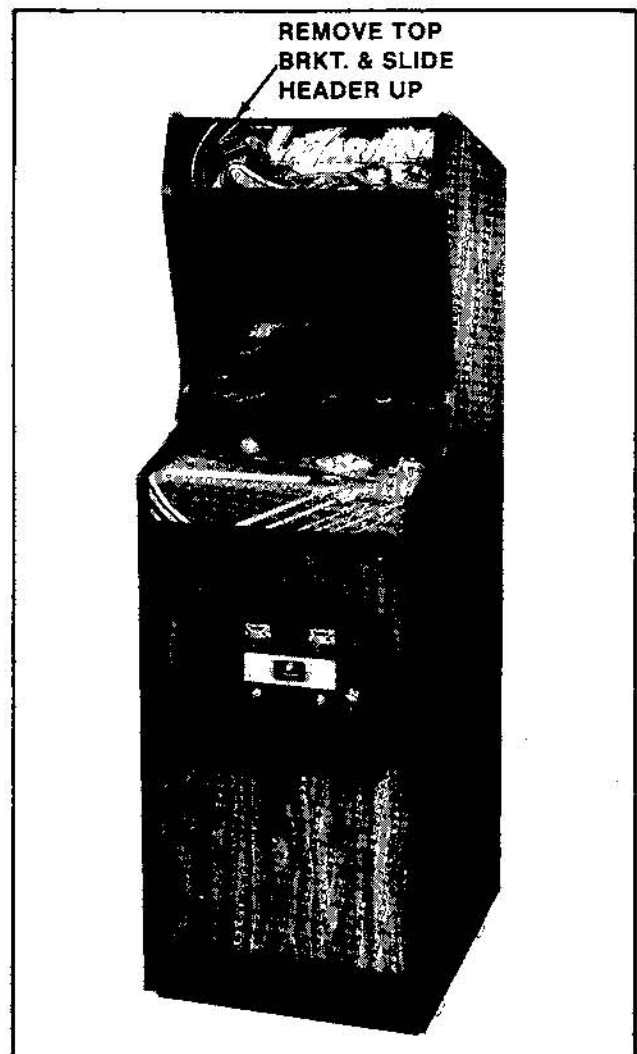
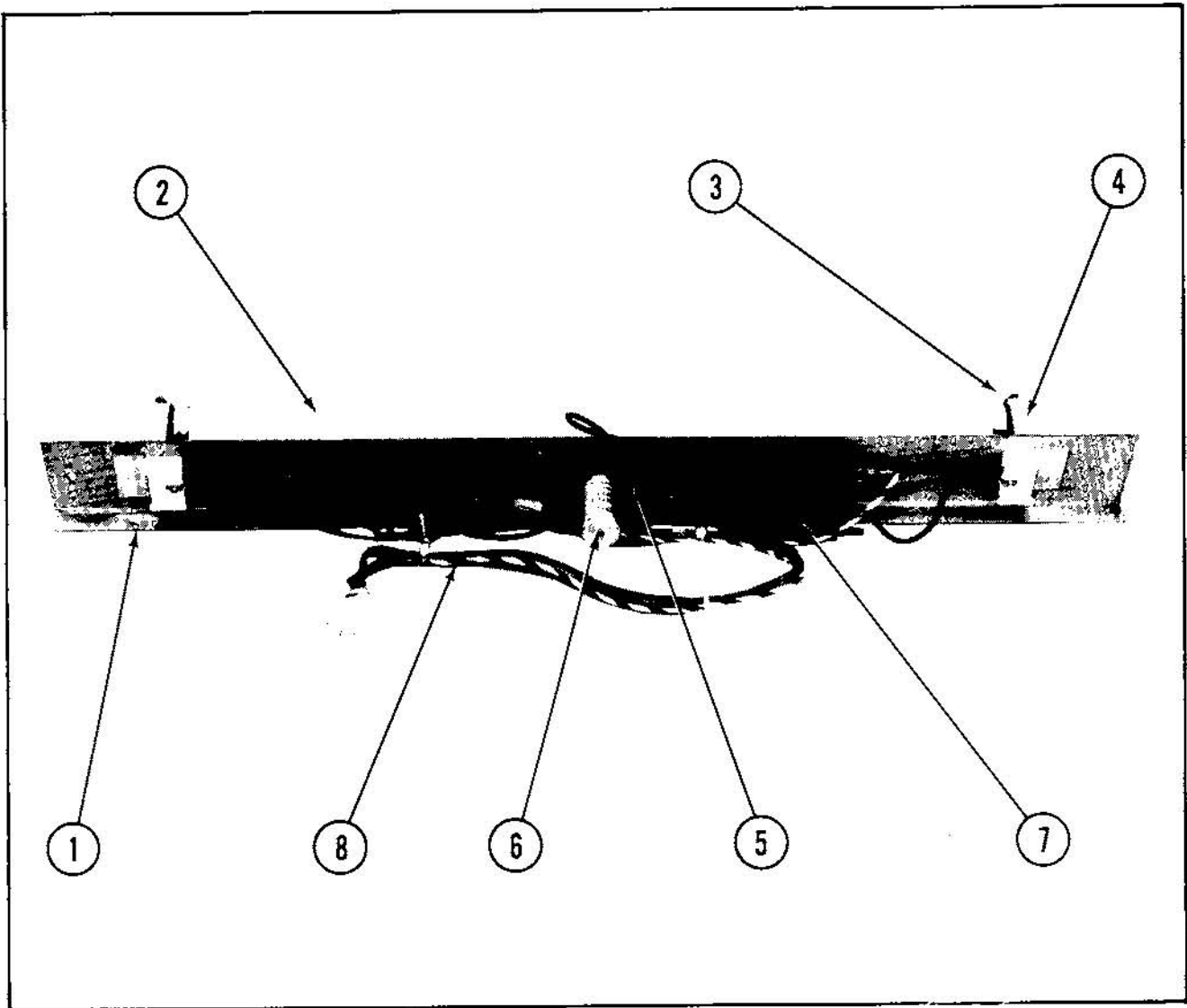

Figure 4-17 Opening the Attraction Panel — Mini

V Illustrated Parts Breakdown

NO. 636 — LAZARIAN UPRIGHT — HEADER FLUORESCENT FIXTURE ASSY.



NO. 636 — LAZARIAN UPRIGHT — HEADER FLUORESCENT FIXTURE ASSY. — PARTS LIST

ORDER BY PART NUMBER ONLY

ITEM	PART NO.	DESCRIPTION
1	0595-00105-0000	FLUORESCENT BRKT.
2	0017-00003-0043	18" COOL WHITE FLUORESCENT LAMP
3	0017-00003-0445	LAMP LOCKS (2 REQ'D.)
4	0017-00031-0036	FLUORESCENT SOCKET (2 REQ'D.)
5	0017-00003-0412	FLUORESCENT STARTER HOLDER W/WIRE LEADS
	0017-00101-0573	#6-32 x 1/2 PHIL. RND. HD. M.S. (4 REQ'D.)
	0017-00104-0009	#6 EXT. WASHER (4 REQ'D.)
6	0017-00003-0019	FLUORESCENT STARTER
7	0017-00003-0026	BALLAST
	0017-00101-0598	#8-32 x 5/16 SLT. HEX HD. SCREW (4 REQ'D.)
	A961-00042-0000	LINE FILTER ASSY. (NOT SHOWN)

NO. 636 — LAZARIAN UPRIGHT — FRONT

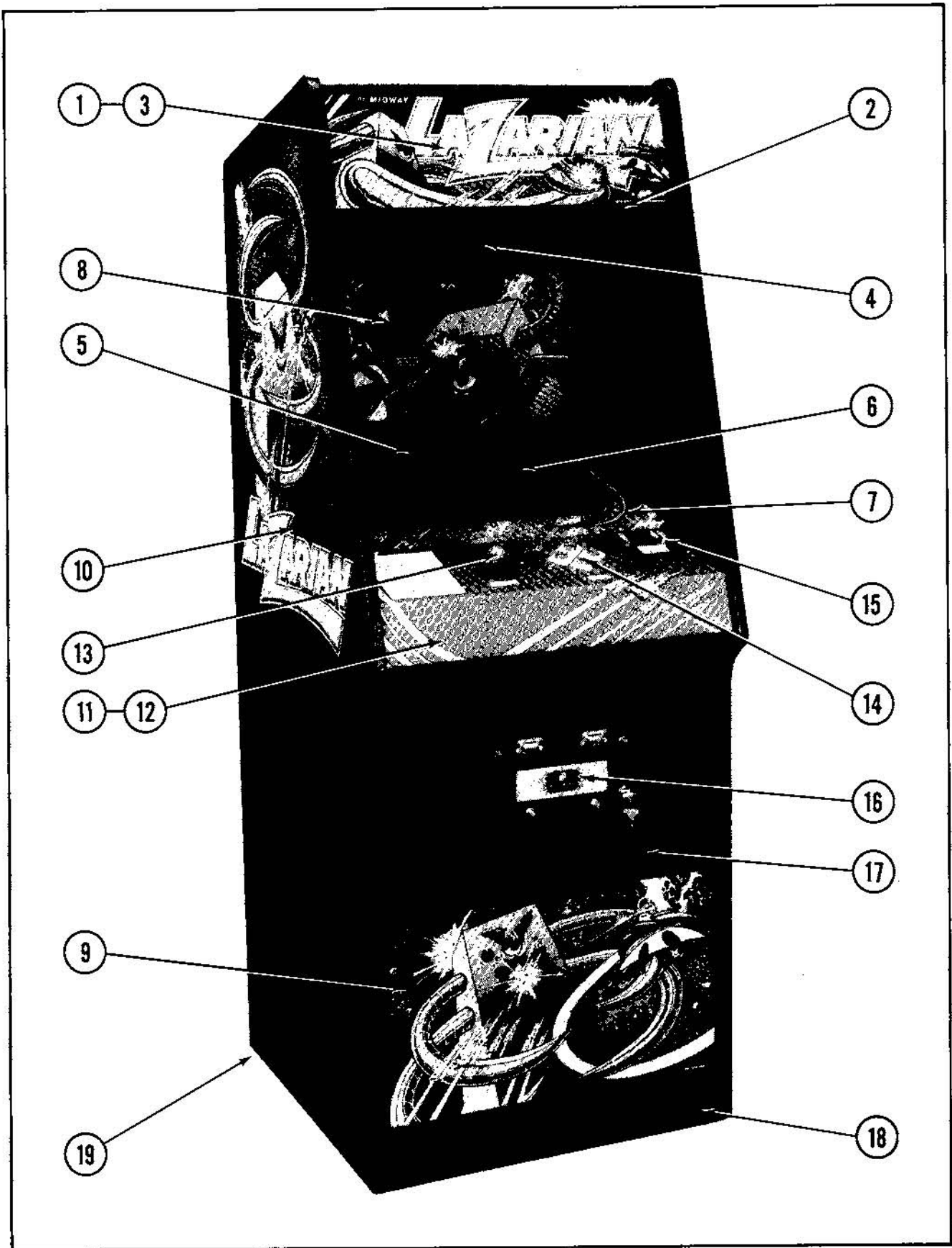

NO. 636 — LAZARIAN UPRIGHT — FRONT — PARTS LIST

ORDER BY PART NUMBER ONLY

ITEM	PART NO.	DESCRIPTION
1	0636-00900-00XF 0537-00903-0058	DISPLAY HEADER GLASS CHANNEL 6-15/16 (2 REQ'D.)
2	0636-00102-00XF 0017-00101-0138 0017-00009-0522	RETAINING BRKT. (2 REQ'D.) #8 x 5/8 TORX TAMPER RESISTANT SCREWS (6 REQ'D.) LONG ARM KEY T-20 (FOR ABOVE SCREW)
3	A595-00011-0000	HEADER FLUORESCENT LIGHT ASSY.
4	0017-00009-0393 0017-00003-0430 0017-00101-0136 0017-00103-0061	BLACK SPEAKER GRILLE W/SLOTS 6" x 9" SPEAKER 4 OHM 10W. #8-32 x 1-1/4 CARRIAGE BOLT (4 REQ'D.) #8-32 HEX NUT W/SEMS (4 REQ'D.)
5	0508-00900-0000	T.V. BEZEL
6	0508-00905-0000 0508-00901-0000 0017-00101-0017	T.V. PLEXI-GLASS (GRAYLITE #31) — 17-3/8" x 13-1/4" x 1/8" PLEXI-GLASS CLIPS (4 REQ'D.) #6 x 1/2 SLT. HEX HD. SCREW (4 REQ'D.)
7	0636-00901-00XF 0508-00108-0000 0017-00101-0027	MAIN VIEWING GLASS GLASS STOP BRKT. — CABINET REAR #8 x 3/4 SLT. HEX HD. SCREW (3 REQ'D.)
8	0636-00904-00XF	REAR SCENERY
9	0636-00905-0000	FRONT DECAL
10	0636-00906-0100 0636-00906-0200	LEFT SIDE DECAL RIGHT SIDE DECAL
11	A636-00006-0000 0961-00115-00XF 0017-00101-0620 0017-00103-0061 0017-00009-0033 0017-00101-0141 0550-00101-0100 0550-00101-0200 0555-00901-0000	STRIKE TO CONTROL PANEL ASSY. STRIKE (2 REQ'D.) #8-32 x 1/2 CARRIAGE BOLT (10 REQ'D.) #8-32 HEX NUT W/SEMS (12 REQ'D.) LATCH CLAMP (3 REQ'D.) #8 x 11/16 UNSLOT. HEX HD. SCREW (6 REQ'D.) CONTROL SHELF MTG. BRKT. — RIGHT CONTROL SHELF MTG. BRKT. — LEFT LOCATING PIN (4 REQ'D.)
12	0636-00903-0000	CONTROL SHELF OVERLAY — DECORATIVE
13	A557-00006-0000	CONTROL ASSY.
14	0017-00032-0093 0017-00042-0299 0017-00103-0054	PUSH BUTTON SWITCH W/HOLDER (4 REQ'D.) YELLOW/RED SQUARE PUSH BUTTON ASSY. (4 REQ'D.) 5/8-11 PAL NUT (4 REQ'D.)
15	0017-00032-0051	SMALL RED PUSH BUTTON SWITCH (2 REQ'D.)
16	A090-00300-10BK	U.S.A. 25¢ COIN DOOR ASSY.
17	0090-00002-04BK 0017-00101-0121	LARGE COIN DOOR FRAME #6-32 x 5/16 PHIL. TRS. HD. SCREW (3 REQ'D.) (MOUNTS COIN DOOR TO FRAME)
18	0935-00906-0100	KICK PLATE — 23" LONG
19	0017-00102-0048 0017-00103-0026	3/8-16 x 2" LEG LEVELERS (4 REQ'D.) 3/8-16 LEG LEVELER NUTS (4 REQ'D.)

NO. 636 — LAZARIAN UPRIGHT — REAR ACCESS

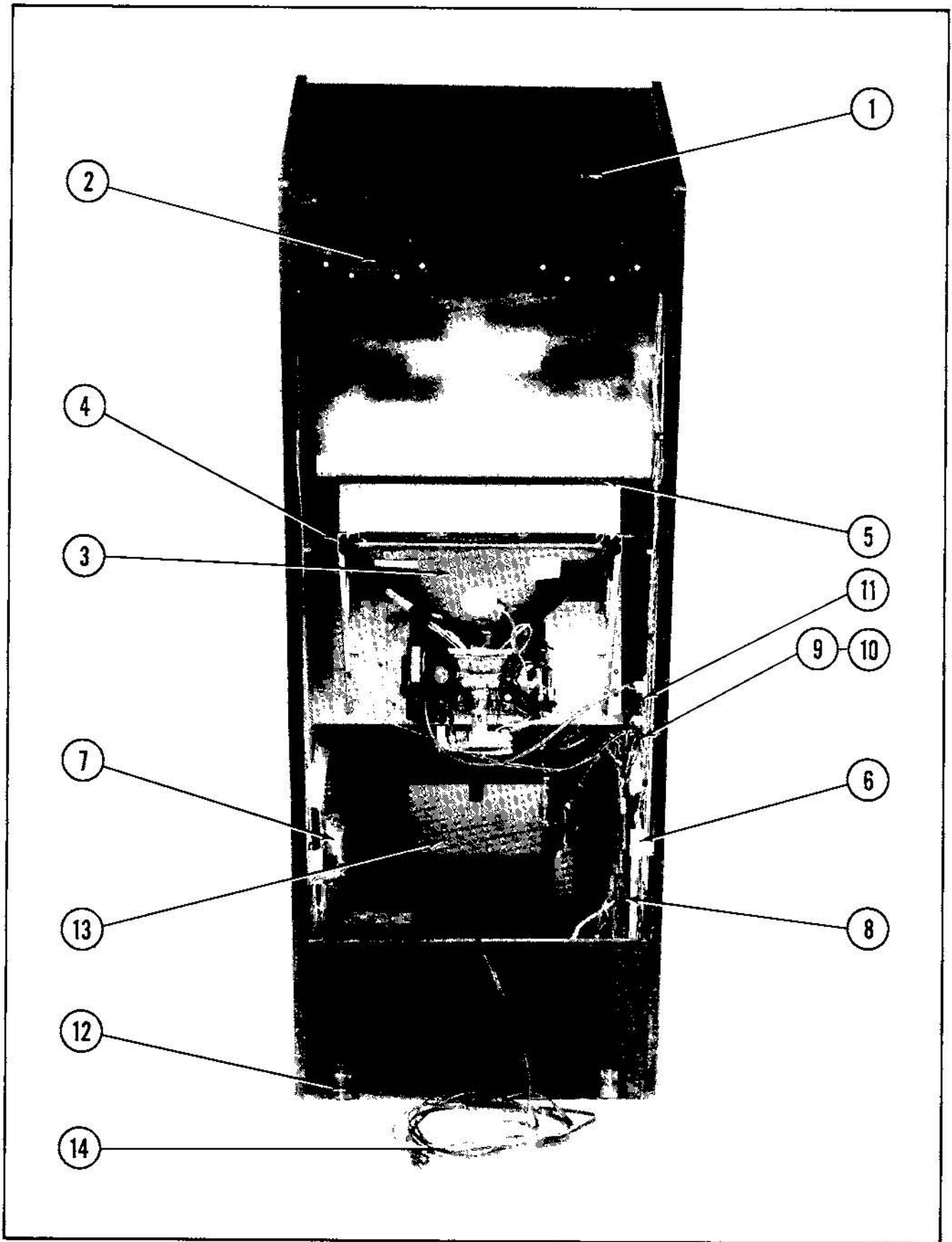

NO. 636 — LAZARIAN UPRIGHT — REAR ACCESS — PARTS LIST

ORDER BY PART NUMBER ONLY

ITEM	PART NO.	DESCRIPTION
1	A088-00013-0000	ON/OFF SWITCH AND BRKT. ASSY.
2	0894-00916-0000	PLASTIC PULL AND VENT (2 REQ'D.)
3	0017-00003-0339	ELECTROHOME 19" COLOR DUAL SYNC. HORIZ. MTG. MONITOR (OR)
3	0017-00003-0439	WELLS GARDNER 19" COLOR DUAL SYNC. HORIZ. MTG. MONITOR
4	0636-00101-0000	MONITOR RAIL (2 REQ'D.)
	0017-00102-0006	1/4-20 x 3/4 SQR. NECK BOLT (4 REQ'D.)
	0017-00104-0014	7/8 DISH WASHER (4 REQ'D.)
	0017-00103-0018	1/4-20 HEX NUT (4 REQ'D.)
	0017-00101-0141	#8 x 11/16 UNSLOT HEX HD. SCREW (8 REQ'D.)
	0555-00901-0000	LOCATING PIN (4 REQ'D.)
5	0508-00900-0000	T.V. BEZEL
6	A088-00015-0000	INTERLOCK SWITCH AND BRKT. ASSY.
7	A082-90421-B000	POWER SUPPLY PCB ASSY.
8	A084-91419-C636	GAME LOGIC BOARD ASSY.
	0624-00902-0100	P.C. SUPPORT BRKT. 12" LG (4 REQ'D.)
	0624-00902-0500	P.C. SUPPORT BRKT. 6-1/2" LG. (4 REQ'D.)
9	A084-90911-E636	SOUND BOARD ASSY.
10	A084-91421-C636	DIODE P.C. BOARD ASSY.
11	A084-91422-B636	MONITOR INTERFACE BOARD ASSY.
12	A961-00007-0000	CASTER ASSY. (2 REQ'D.)
	0961-00109-0000	WHEEL BRKT. (2 REQ'D.)
	0017-00042-0255	PLASTIC WHEEL (2 REQ'D.)
	0894-00702-00XF	SHAFT (2 REQ'D.)
	0017-00100-0037	3/8" E-RING (2 REQ'D.)
13	A950-00004-0000	COIN BOX ASSY.
	A950-00006-0000	COIN BOX CRADLE ASSY.
	0950-00105-0000	COIN BOX COVER
	0950-00104-0000	COIN BOX HANDLE
	0950-00101-0000	COIN DEFLECTOR (2 REQ'D.)
	0950-00900-0000	LARGE PLASTIC CASH BOX
	0017-00101-0142	1/4-20 x 1-3/8 RND. HD. BOLT (4 REQ'D.)
	0017-00104-0014	7/8 DISH WASHER (4 REQ'D.)
	0017-00103-0018	1/4-20 HEX NUT (4 REQ'D.)
14	A508-00023-0000	3 COND. LINE CORD ASSY.
		ADDITIONAL PARTS LIST
	A636-00013-0000	TRANSFORMER BOARD ASSY.
	A097-00009-0000	BACK DOOR LOCK ASSY.
	0017-00009-0490	5-5/8" SQR. VENT GRILLE (4 REQ'D.)
	3010-03003-0000	GROUNDING CLIP
	A636-00014-0000	VIDEO SIGNAL CABLE ASSY.
	A636-00017-0000	VIDEO SIGNAL ADAPTOR CABLE ASSY.
	A636-00018-0000	AUDIO ADAPTOR CABLE ASSY.
	A636-00012-0000	CONTROL SHELF CABLE ASSY.
	A636-00010-0000	MASTER CABLE ASSY.
	A636-00016-0000	COIN DOOR CABLE ASSY.
	A636-00015-0000	HIGH VOLTAGE CABLE ASSY.
	A641-00011-0000	LOW VOLTAGE CABLE ASSY.
	0508-00106-0000	T.V. BEZEL MTG. BRKT. (2 REQ'D.)
	0508-00108-0000	MAIN VIEWING GLASS STOP BRKT.
	0017-00101-0027	#8 x 3/4 SLT. HEX HD. SCREW (3 REQ'D.)

NO. 641 — LAZARIAN MINI — FRONT

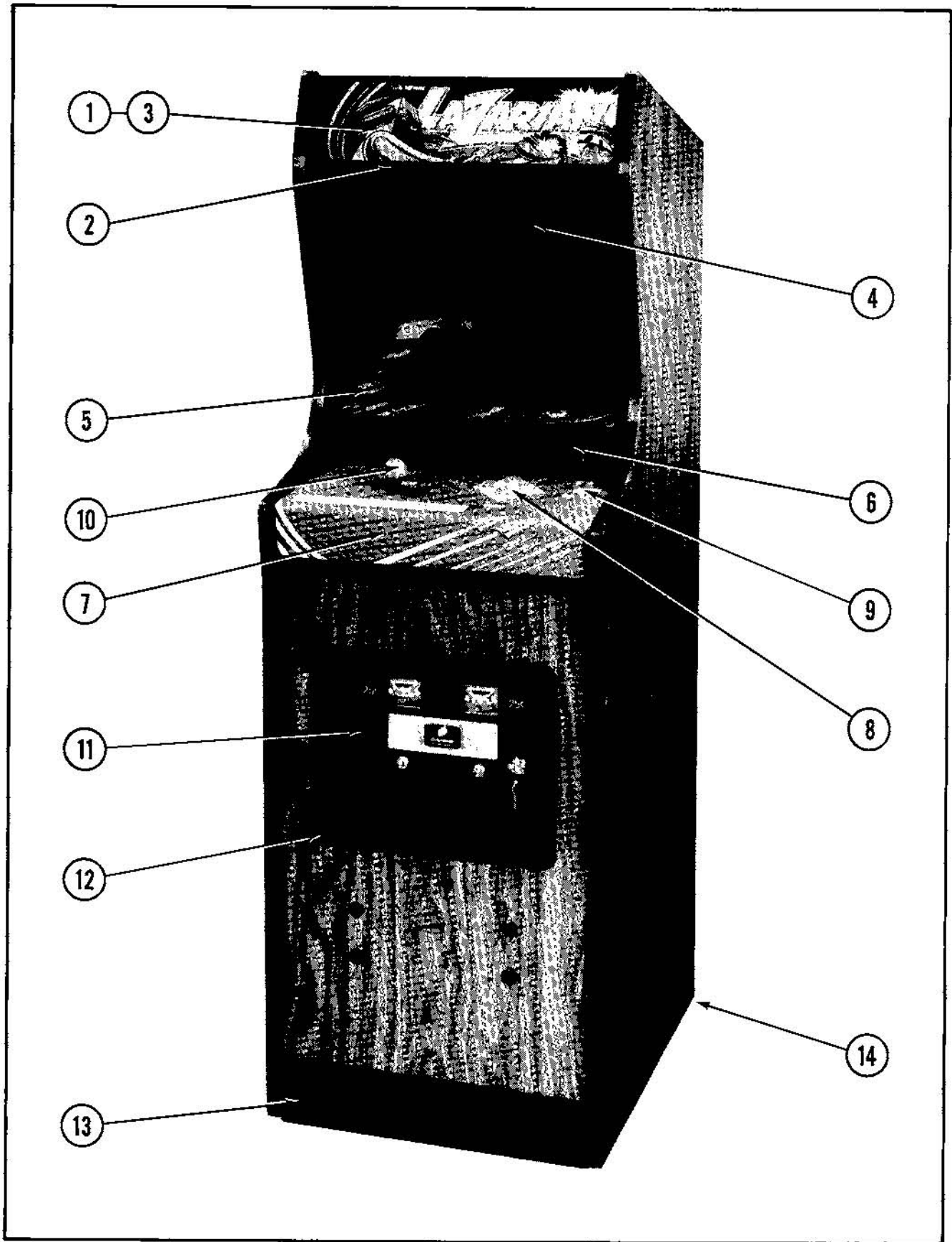

NO. 641 — LAZARIAN MINI — FRONT — PARTS LIST

ORDER BY PART NUMBER ONLY

ITEM	PART NO.	DESCRIPTION
1	0641-00901-00XF	DISPLAY HEADER
	0537-00903-0060	GLASS CHANNEL 4-1/2" (2 REQ'D.)
2	0574-00100-00XF	HEADER RETAINING BRKT. (2 REQ'D.)
	0017-00101-0138	#8 x 5/8 TORX TAMPER RESISTANT SCREWS (8 REQ'D.)
	0017-00009-0522	LONG ARM KEY T-20 (FOR ABOVE SCREW)
3	A574-00007-0000	INSERT ASSY.
	0017-00031-0030	WEDGE BASE LAMP SOCKET (5 REQ'D.)
	0017-00003-0219	#194 LAMP 14V., .27A. (5 REQ'D.)
4	0017-00009-0393	BLACK SPEAKER GRILLE W/SLOTS
	0017-00003-0430	6" x 9" SPEAKER 4 OHM, 10W.
	0017-00101-0127	#8-32 x 1-1/2 CARRIAGE BOLTS (4 REQ'D.)
	0017-00103-0061	#8-32 HEX NUT W/SEMS (4 REQ'D.)
5	0641-00900-00XF	VIEWING GLASS
	0537-00903-0056	GLASS CHANNEL 14-1/2" (2 REQ'D.)
6	A555-00016-0000	GLASS CLAMPING PLATE
7	0641-00100-0000	CONTROL SHELF PLATE
	0641-00902-0000	CONTROL SHELF OVERLAY
	0017-00101-0620	#8-32 x 1/2 CARRIAGE BOLT (8 REQ'D.)
	0017-00103-0061	#8-32 HEX NUT W/SEMS (8 REQ'D.)
	0550-00101-0100	CONTROL SHELF MTG. BRKT. — RIGHT
	0550-00101-0200	CONTROL SHELF MTG. BRKT. — LEFT
	0555-00901-0000	PLASTIC LOCATING PIN (8 REQ'D.)
	0017-00009-0033	LATCH CLAMP (2 REQ'D.)
	0961-00115-00XF	STRIKE (2 REQ'D.)
	0017-00101-0141	#8 x 11/16 UNSLOT HEX HD. SCREW (16 REQ'D.)
	8	0017-00032-0051
9	0017-00032-0093	PUSH BUTTON SWITCH W/HOLDER (4 REQ'D.)
	0017-00042-0299	YELLOW/RED SQUARE PUSH BUTTON ASSY. (4 REQ'D.)
	0017-00103-0054	5/8-11 PAL NUT
10	A557-00006-0000	CONTROL ASSY.
11	A090-00300-10BK	U.S.A. 25¢ COIN DOOR ASSY.
12	0090-00002-04BK	LARGE COIN DOOR FRAME
13	0935-00906-0400	KICK PLATE
14	0017-00102-0048	3/8-16 x 2 LEG LEVELERS (4 REQ'D.)
	0017-00103-0026	3/8-16 LEG LEVELER NUTS (4 REQ'D.)

NO. 641 — LAZARIAN MINI — REAR ACCESS

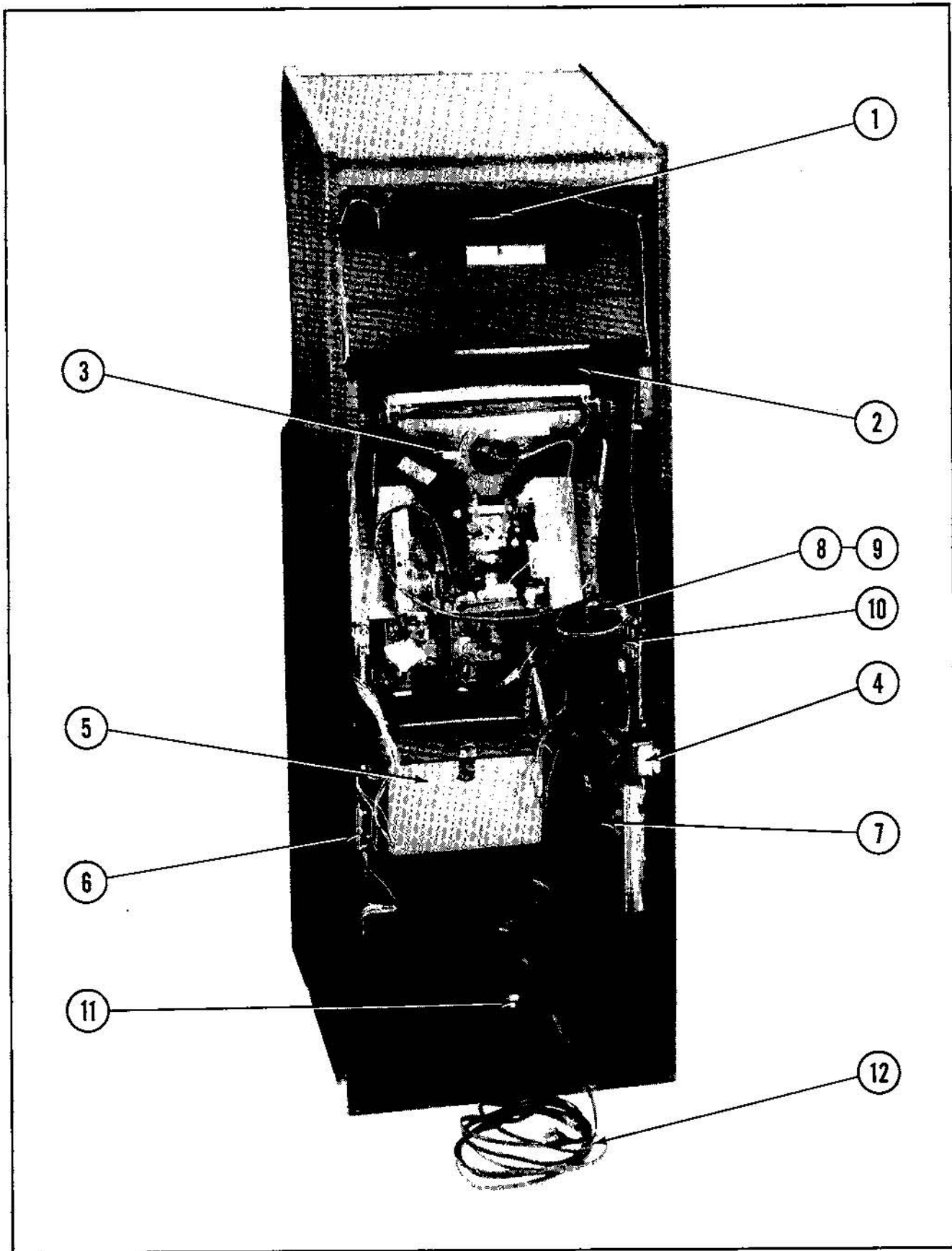

NO. 641 — LAZARIAN MINI — REAR ACCESS — PARTS LIST

ORDER BY PART NUMBER ONLY

ITEM	PART NO.	DESCRIPTION
1	0017-00003-0430	6" x 9" SPEAKER 4 OHM, 10W.
2	0931-00903-0000	T.V. BEZEL
	0934-00905-0000	PLEXI-GLASS
	A961-00026-0000	BEZEL MTG. BRKT. ASSY.
3	0017-00003-0340	ELECTROHOME — 13" COLOR DUAL SYNC. HORIZ. MTG. MONITOR (OR)
3	0017-00003-0435	WELLS GARDNER — 13" COLOR DUAL SYNC. HORIZ. MTG. MONITOR
	0555-00100-0000	MONITOR MTG. BRKT. (2 REQ'D.)
4	A088-00015-0000	INTERLOCK SWITCH & BRKT. ASSY.
5	A950-00006-0000	COIN BOX CRADLE ASSY.
	0950-00105-0000	COIN BOX COVER
	0950-00104-0000	COIN BOX HANDLE
	0950-00101-00XF	COIN DEFLECTOR (2 REQ'D.)
	0950-00900-0000	LARGE PLASTIC CASH BOX
	0017-00101-0142	1/4-20 x 1-3/8 RND. HD. BOLT (4 REQ'D.)
	0017-00104-0014	7/8 DISH WASHER (4 REQ'D.)
	0017-00103-0018	1/4-20 HEX NUT (4 REQ'D.)
6	A082-90421-B000	POWER SUPPLY P.C. ASSY.
7	A084-91419-C636	GAME LOGIC BOARD ASSY.
	0624-00902-0100	P.C. SUPPORT BRKT. 12" (4 REQ'D.)
	0624-00902-0300	P. C. SUPPORT BRKT. 2-1/2" (2 REQ'D.)
	0624-00902-0500	P.C. SUPPORT BRKT. 6-1/2" (2 REQ'D.)
8	A084-90911-E636	SOUND BOARD ASSY.
9	A084-91422-B636	MONITOR INTERFACE P.C. ASSY.
10	A084-91421-C636	DIODE P.C. ASSY.
11	A088-00013-0000	ON/OFF SWITCH & BRKT. ASSY.
12	0017-00009-0490	5-5/8" SQR. VENT GRILLE (4 REQ'D.)
ADDITIONAL PARTS LIST		
	A097-00009-0000	BACK DOOR LOCK ASSY.
	A641-00012-0000	CONTROL SHELF CABLE ASSY.
	A641-00007-0000	MASTER CABLE ASSY.
	A636-00014-0000	VIDEO SIGNAL CABLE ASSY.
	A636-00017-0000	VIDEO SIGNAL ADAPTOR CABLE ASSY.
	A636-00018-0000	AUDIO ADAPTOR CABLE ASSY.
	A641-00006-0000	HIGH VOLTAGE CABLE ASSY.
	A641-00011-0000	LOW VOLTAGE CABLE ASSY.
	A574-00015-0000	INSERT CABLE ASSY.
	A636-00016-0000	COIN DOOR CABLE ASSY.
	A508-00023-0000	3 COND. LINE CORD

NO. 646 — LAZARIAN COCKTAIL — FRONT

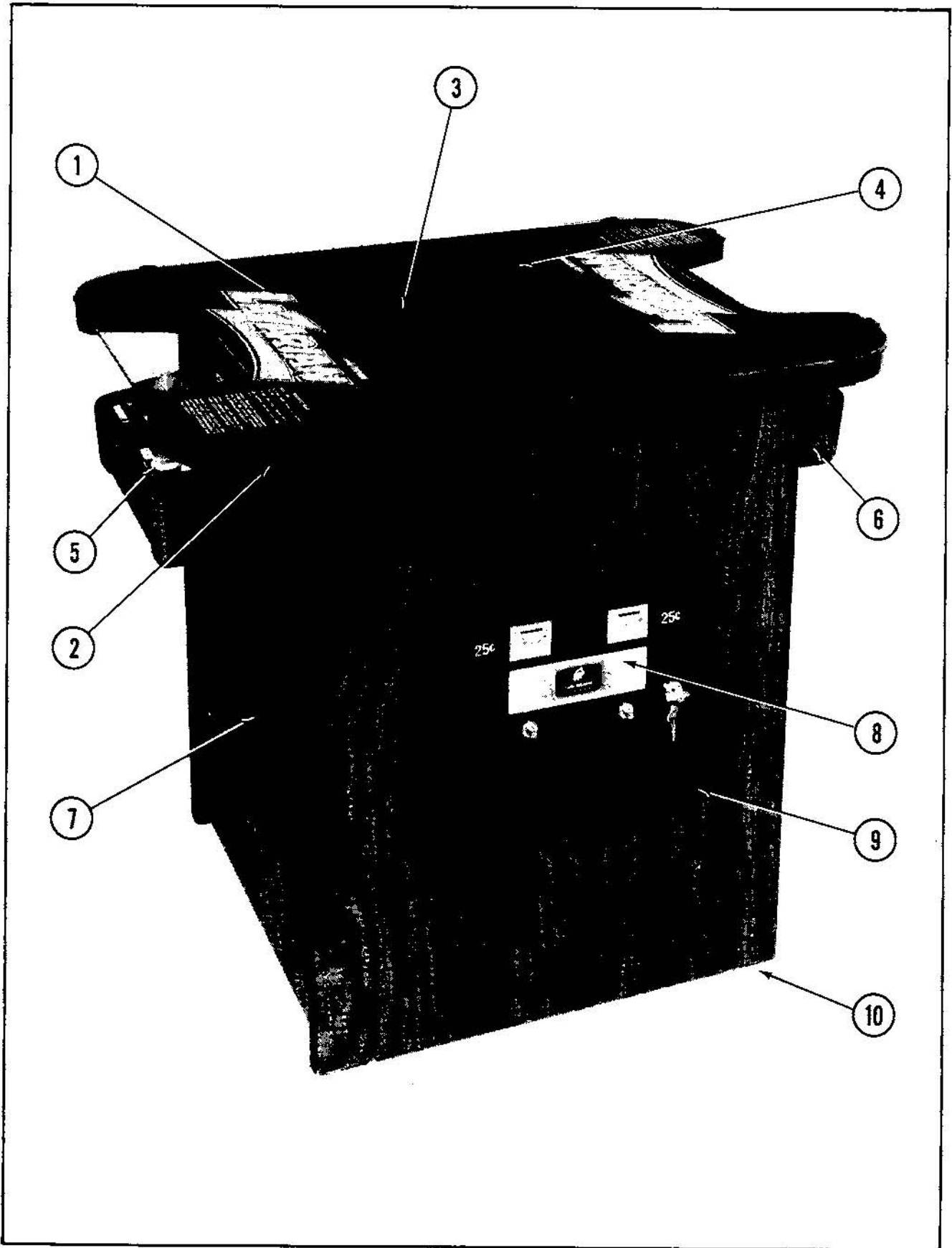

NO. 646 — LAZARIAN COCKTAIL — FRONT — PARTS LIST

ORDER BY PART NUMBER ONLY

ITEM	PART NO.	DESCRIPTION
1	0017-00009-0499 0646-00900-0000	COVER GLASS — 32" x 22" x 1/4" ARTWORK UNDERLAY
2	0775-00104-00XF 0017-00101-0117	GLASS CLIPS (8 REQ'D.) #8 x 5/8 PHIL. TRS. HD. SCREW (16 REQ'D.)
3	0508-00905-0000	T.V. PLEXI-GLASS (GRAYLITE #31) — 17-3/8" x 13-1/4" x 1/8"
4	0557-00900-0000	T.V. BEZEL
5	A646-00004-0100	CONTROL SHELF ASSY. — PLAYER #1
6	A646-00004-0200	CONTROL SHELF ASSY. — PLAYER #2
7	0017-00009-0393 0017-00003-0430 0017-00101-0136 0017-00103-0061	BLACK SPEAKER GRILLE W/SLOTS (2 REQ'D.) 6" x 9" SPEAKER 4 OHM, 10W. #8-32 x 1-1/4 CARRIAGE BOLT (8 REQ'D.) #8-32 HEX NUT W/SEMS (8 REQ'D.)
8	A090-00300-10BK	U.S.A. 25¢ COIN DOOR ASSY.
9	0090-00002-02BK 0017-00101-0121	LARGE COIN DOOR FRAME #6-32 x 5/16 PHIL. TRS. HD. SCREW (3 REQ'D.) (MOUNTS COIN DOOR TO FRAME)
10	0017-00102-0048 0017-00103-0026	3/8-16 x 2" LEG LEVELERS (4 REQ'D.) 3/8-16 LEG LEVELER NUTS (4 REQ'D.)

NO. 646 — LAZARIAN COCKTAIL — INTERIOR ACCESS

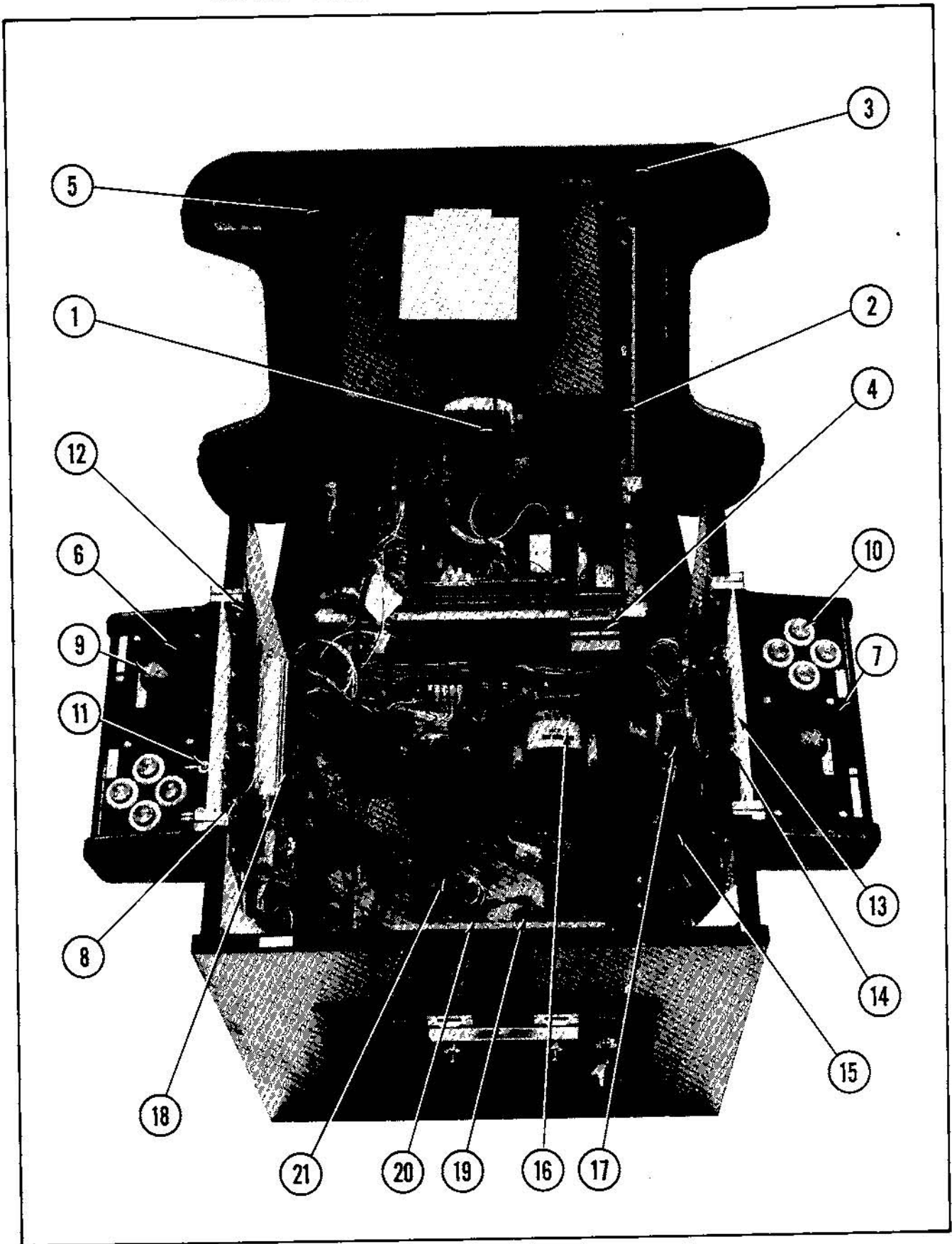

NO. 646 — LAZARIAN COCKTAIL — INTERIOR ACCESS — PARTS LIST

ORDER BY PART NUMBER ONLY

ITEM	PART NO.	DESCRIPTION
	0017-00003-0450	WELLS GARDNER — 19" COLOR DUAL SYNC HORIZ. MTG. MONITOR
2	A557-00004-00XF	MONITOR MTG. BRKT. ASSY. (2 REQ'D.)
	0017-00101-0127	#8-32 x 1-1/2 CARRIAGE BOLT (4 REQ'D.)
	0017-00104-0037	#8 FLAT WASHER (4 REQ'D.)
	0017-00103-0061	#8-32 HEX NUT W/SEMS (4 REQ'D.)
	0017-00102-0002	1/4-20 x 1/2 SLT. HEX HD. BOLT (4 REQ'D.)
	0017-00102-0052	1/4-20 x 1 UNSLOT HEX FLAT HD. BOLT (4 REQ'D.)
	0017-00104-0014	7/8 DISH WASHER (8 REQ'D.)
3	0921-00107-00XF	STRIKE (2 REQ'D.)
	0017-00101-0769	#10 x 3/4 SLT. HEX HD. SCREW (4 REQ'D.)
	0017-00009-0033	LATCH CLAMP (2 REQ'D.)
	0017-00101-0141	#8 x 11/16 UNSLOT HEX HD. SCREW (4 REQ'D.)
4	0017-00009-0514	2-1/2" HINGE (2 REQ'D.)
	0017-00101-0628	#8-32 x 3/4 CARRIAGE BOLT (4 REQ'D.)
	0017-00101-0639	#8-32 x 1-1/4 CARRIAGE BOLT (4 REQ'D.)
	0017-00103-0061	#8-32 HEX NUT W/SEMS (4 REQ'D.)
5	0557-00900-0000	BEZEL
6	0646-00102-01XF	CONTROL SHELF — PLAYER #1
7	0646-00102-02XF	CONTROL SHELF — PLAYER #2
8	0510-00101-00XF	BOTTOM PAN (2 REQ'D.)
9	A557-00006-0000	CONTROL ASSY. (2 REQ'D.)
	A646-00012-0100	CONTROL SHELF CABLE ASSY. — PLAYER #1
	A646-00012-0200	CONTROL SHELF CABLE ASSY. — PLAYER #2
10	0017-00042-0306	RED/YELLOW PUSH BUTTON ASSY. (8 REQ'D.)
	A646-00006-0000	SWITCH MTG. BRKT. ASSY. (2 REQ'D.)
	A646-00007-0000	SWITCH ASSY. (8 REQ'D.)
	0017-00103-0054	5/8-11 PAL NUT
11	0017-00032-0051	SMALL RED BUTTON SWITCH (2 REQ'D.) PLAYER #1 PANEL ONLY
12	0930-00104-0000	CONTROL PANEL LOCATING BRKT. (4 REQ'D.)
	0017-00101-0025	#8 x 1/2 SLT. HEX HD. SCREW (16 REQ'D.)
13	0930-00904-0000	LIGHT SHIELD (2 REQ'D.)
14	0017-00031-0044	WEDGE BASE LAMP SOCKET (4 REQ'D.)
	0017-00003-0219	#194 LAMP 14V., .27A. (4 REQ'D.)
	0017-00101-0555	#6-32 x 5/16 SLT. HEX HD. SCREW (4 REQ'D.)
15	0017-00003-0430	6" x 9" SPEAKER 4 OHM, 10W.
16	A646-00009-0000	TRANSFORMER BOARD ASSY.
17	A082-90421-B000	POWER SUPPLY PC ASSY.
18	A084-91419-C636	GAME LOGIC BOARD ASSY.
	0624-00902-0100	P.C. SUPPORT BRKT. 12" LG. (4 REQ'D.)
	0624-00902-0300	P.C. SUPPORT BRKT. 2-1/2" LG.
	0624-00902-0500	P.C. SUPPORT BRKT. 6-1/2" LG. (3 REQ'D.)
19	A084-90911-E636	SOUND BOARD ASSY.
20	A084-91421-C636	DIODE P.C. ASSY.
21	A084-91422-B636	MONITOR INTERFACE P.C. BOARD ASSY.

NO. 646 — LAZARIAN COCKTAIL — INTERIOR ACCESS — PARTS LIST (Continued)

ORDER BY PART NUMBER ONLY

ITEM	PART NO.	DESCRIPTION
		ADDITIONAL PARTS LIST
	A775-00013-0000	FAN ASSEMBLY
	0151-00081-0000	4" FAN
	0775-00110-00XF	FAN PLATE
	0749-00106-00XF	VENT SCREEN
	0017-00101-0347	#6-32 x 1/2 R.H.M.S. (4 REQ'D.)
	0017-00104-0009	#6 EXT. WASHER (4 REQ'D.)
	0017-00103-0005	#6-32 HEX NUT (4 REQ'D.)
	0017-00101-0026	#8 x 5/8 SLT. HEX HD. SCREW (4 REQ'D.)
	A088-00013-0000	ON/OFF SWITCH & BRKT. ASSY.
	A927-00019-0000	COIN BOX ASSY.
	A962-00004-0000	COIN BOX COVER ASSY.
	A962-00005-0000	COIN BOX SIDE CHANNEL ASSY. — SHORT
	0962-00101-0000	COIN BOX SIDE CHANNEL — SHORT
	0017-00101-0628	#8-32 x 3/4 CARRIAGE BOLT (4 REQ'D.)
	0017-00104-0022	#8 WASHER (4 REQ'D.)
	0017-00103-0061	#8-32 HEX NUT W/SEMS (4 REQ'D.)
	A088-00014-0000	INTERLOCK SWITCH & BRKT. ASSY.
	0927-00907-0000	HIGH VOLTAGE SHIELD — FORMED
	A646-00010-0000	MASTER CABLE ASSY.
	A646-00011-0000	HIGH VOLTAGE CABLE ASSY.
	A646-00014-0000	LOW VOLTAGE CABLE ASSY.
	A636-00016-0000	COIN DOOR CABLE ASSY.
	A636-00014-0000	VIDEO SIGNAL CABLE ASSY.
	A636-00017-0000	VIDEO SIGNAL ADAPTOR CABLE ASSY.
	A636-00018-0000	AUDIO ADAPTOR CABLE ASSY.
	A927-00005-0000	HIGH BASE LEG KIT ASSY. — OPTIONAL
	A508-00023-0000	3 COND. LINE CORD ASSY.

**LAZARIAN TRANSFORMER BOARD ASSY. — PARTS LIST
(NO PHOTOGRAPH)**

ORDER BY PART NUMBER ONLY

ITEM	PART NO.	DESCRIPTION
	MT00-00092-0000	TRANSFORMER — UPRIGHT & MINI
	MT00-00087-0000	POWER TRANSFORMER 120/240V. — UPRIGHT & MINI
	MT00-00091-0000	SHIELDED TRANSFORMER 115/220V. — COCKTAIL ONLY
	MT00-00093-0000	TRANSFORMER W/MAGNETIC SHIELD — COCKTAIL ONLY
	0720-00001-0200	2 POSITION FUSE CLIP ASSY. (1 REQ'D. U/R & C/T, 2 REQ'D. MINI)
	0720-00001-0300	3 POSITION FUSE CLIP ASSY. — UPRIGHT & COCKTAIL
	0017-00003-0002	SLO BLO FUSE 1/2A., 250V. — UPRIGHT & COCKTAIL
	0017-00003-0004	SLO BLO FUSE 2A., 250V. (3 REQ'D. U/R & MINI, 2 REQ'D. C/T)
	0017-00003-0217	SLO BLO FUSE 2-1/2A., 250V. (1 REQ'D. MINI, 2 REQ'D. C/T)
	0017-00003-0261	SLO BLO FUSE 1-1/2A., 250V. — UPRIGHT
	A151-00079-0000	115V. CONVENIENCE OUTLET
	A508-00037-0000	2 LEAD TRANSFORMER BOARD FILTER ASSY.
	0017-00003-0064	3 COND. LINE CORD
	3010-13106-0000	TERMINAL STRIP
	0017-00021-0370	MALE CONNECTOR — 5 PAIR
	3000-17246-0500	GROUND STRAP 5-1/2" — UPRIGHT
	3000-17246-1000	GROUND STRAP 36" — UPRIGHT
	3000-17246-0900	GROUND STRAP 48" — MINI
	3000-17246-1100	GROUND STRAP 30" — MINI
	3010-04237-0100	GROUND STRAP — MINI
	3000-17246-0200	GROUND STRAP — COCKTAIL
	3010-04044-0000	GROUND STRAP — 3" — COCKTAIL

LAZARIAN — CONTROL ASSEMBLY — ALL VERSIONS

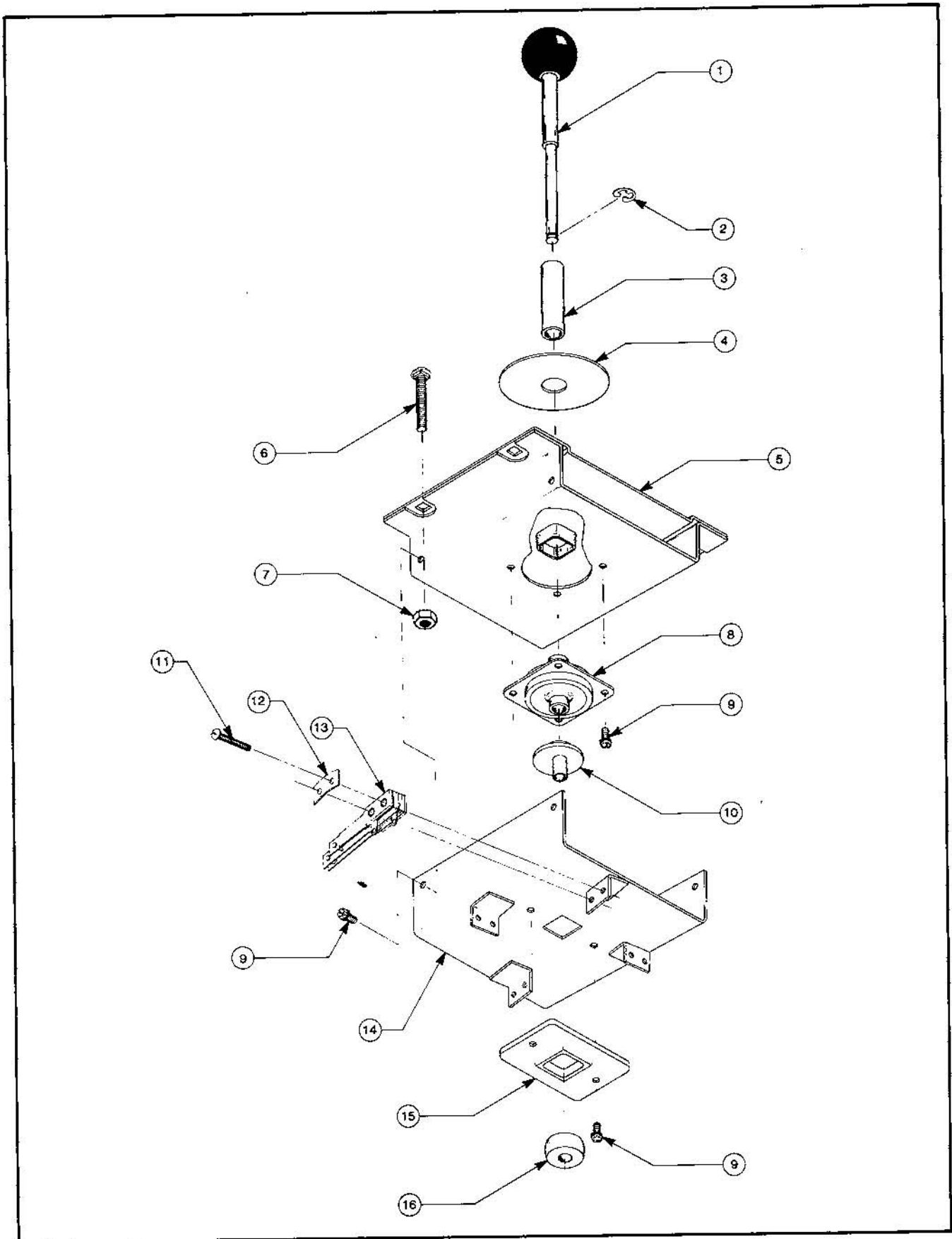

LAZARIAN — CONTROL ASSEMBLY — ALL VERSIONS — PARTS LIST

ORDER BY PART NUMBER ONLY

ITEM	PART NO.	DESCRIPTION
1	A932-00022-0000	BALL & SHAFT ASSEMBLY
2	0017-00100-0025	1/4" E-RING
3	0921-00702-0000	STOP SPACER
4	0921-00902-0000	SLIDE PLATE
5	A557-00005-0000	SPOT WELD ASSEMBLY
6	0017-00101-0637	#8-32 x 1" CARRIAGE BOLT (4 REQ'D.)
7	0017-00103-0061	#8-32 HEX NUT W/SEMS (4 REQ'D.)
8	0932-00902-0000	GROMMET
9	0017-00101-0598	#8-32 x 5/16 SLT. HEX HD. M.S. (10 REQ'D.)
10	0962-00904-0000	SLEEVE
11	0017-00101-0527	#5-40 x 5/8 SLT. RND. HD. SCR. (8 REQ'D.)
12	0020-00202-0000	SWITCH PLATE (4 REQ'D.)
13	A932-00009-0000	SWITCH ASSEMBLY (4 REQ'D.)
14	A921-00009-0000	STOP PLATE & SWITCH BRKT. ASSY.
15	0927-00908-0000	WEAR PLATE
16	0921-00700-0000	ACTUATOR

FRONT DOOR ASSEMBLY — U.S.A. 25c

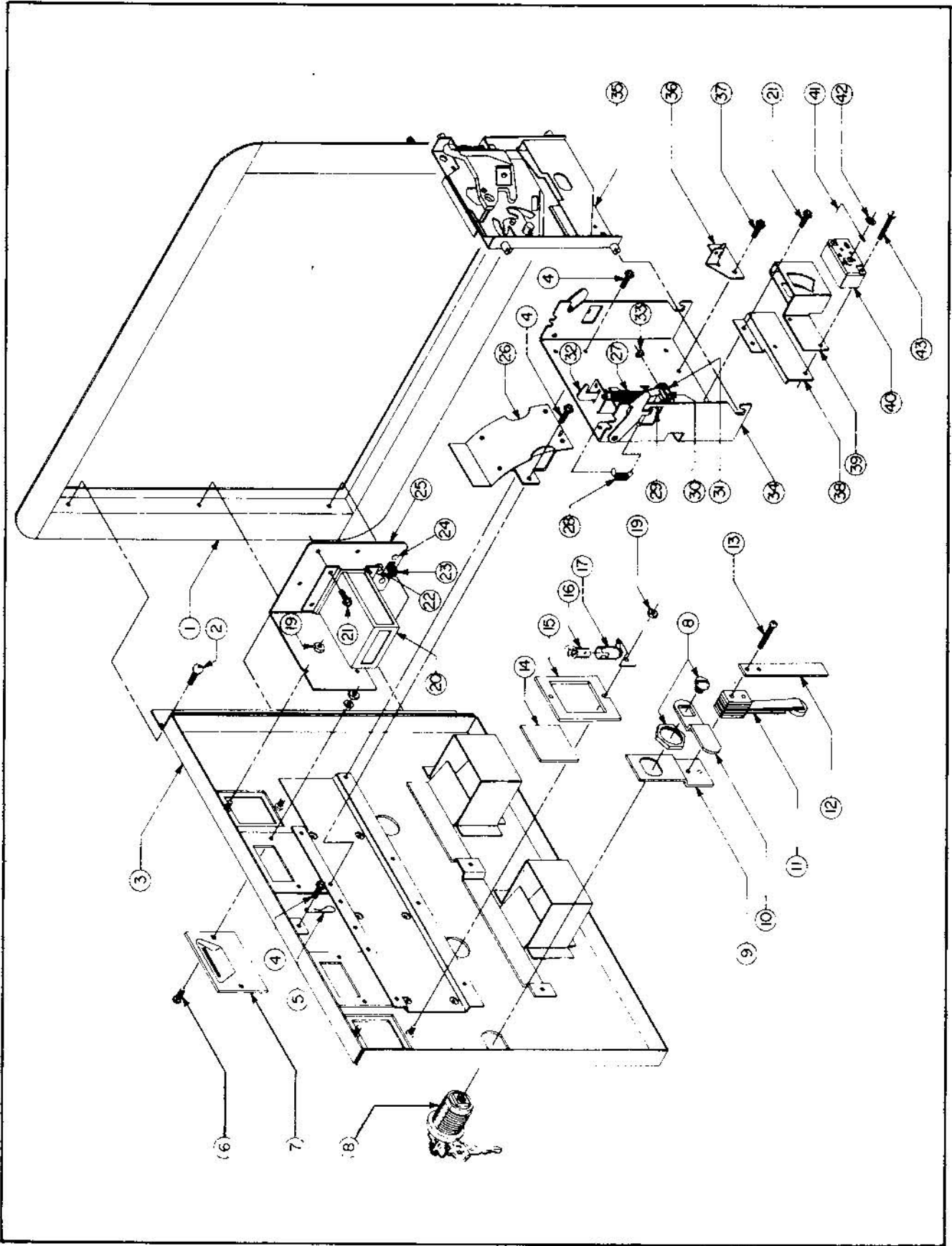

FRONT DOOR ASSEMBLY — U.S.A. 25¢

ORDER BY PART NUMBER ONLY

ITEM	PART NO.	DESCRIPTION
1	0090-00002-02BK	DOUBLE ENTRY COIN DOOR FRAME
2	0017-00101-0121	#6-32 x 5/16 PHIL. TRS. HD. SCR. (3 REQ'D.)
3	A090-00073-02BK	DOUBLE ENTRY COIN DOOR W/DRESS PLATE
4	0017-00101-0123	#8 x 1/4 UNSLOT. HEX HD. SCREW (4 REQ'D.)
5	0017-00007-0019	KEY HOOK
6	0017-00101-0552	#6-32 x 1/4 CARRIAGE BOLT (4 REQ'D.)
7	0090-00117-03XF	COIN ENTRY PLATE — 25¢ (2 REQ'D.)
8	A097-00005-0000	DOOR LOCK & KEY W/SCREW & NUT (OR)
8	A097-00006-0000	DOOR LOCK & KEY W/SCREW & NUT
9	0090-00128-00XF	DOOR TILT SWITCH BRKT.
10	0017-00005-0041	DOOR CAM
11	A090-00096-0000	DOOR TILT SWITCH
12	0090-00126-01XF	SWITCH BACK-UP PLATE
13	0017-00101-0525	#5-40 x 9/16" PHIL. HD. M.S. (2 REQ'D.)
	A090-00096-0000	DOOR TILT SWITCH & BRKT. ASSY. (ITEMS 9 & 11 THRU 13)
14	0090-00903-9500	25¢ WINDOW (2 REQ'D.)
15	0090-00143-00XF	COIN PLEX RETAINER
16	0017-00003-0219	12 VOLT LAMP — G.E. #194 (2 REQ'D.)
17	0017-00031-0048	WEDGE SOCKET W/BRKT. (2 REQ'D.)
19	0017-00103-0084	#6-32 HEX NUT W/SEMS (4 REQ'D.)
20	A090-00089-0000	COIN METER W/DIODE
21	0017-00101-0124	#6 x 1/4 UNSLOT. HEX HD. SCR. (8 REQ'D.)
22	0017-00032-0051	PUSH BUTTON SWITCH
23	0017-00032-0007	SLIDE SWITCH
24	0017-00072-0034	STEEL OVAL HD. RIVET
25	0090-00173-0000	COIN COUNTER MTG. BRKT.
	A090-00082-0100	TEST SWITCH & BRKT. ASSY. (ITEMS 23 THRU 25)
26	A090-00087-0000	COIN CHUTE & TOP ASSY. (2 REQ'D.)
27	0010-00134-0000	SPRING
28	0010-00181-0000	SPRING
29	0017-00007-0083	1/8 x 1-5/8 ROLL PIN
30	0090-00129-00XF	PIVOT POST
31	0090-00167-00XF	PIVOT LEVER
32	0093-00155-00XF	REJECT LEVER
33	0017-00100-0018	E-RING
	A090-00088-0000	REJECT LEVER ASSY. (2 REQ'D.) (ITEMS 30 THRU 33)
34	A090-00085-0000	COIN ACCEPTOR FRAME ASSY. (2 REQ'D.)
35	0017-00005-0003	COIN ACCEPTOR W/STRING CUTTER (2 REQ'D.) (OR)
35	0017-00005-0211	COIN ACCEPTOR W/ANTI STRING DEVICE (2 REQ'D.) (OR)
35	0017-00005-0214	COIN ACCEPTOR W/STRING CUTTER (2 REQ'D.)
36	A090-00064-0000	ANTI-PENNY DEVICE
37	0017-00101-0099	#6 x 1/4 SLT. HEX HD. M.S. (2 REQ'D.)
38	0090-00162-00XF	COIN SWITCH MTG. BRKT.
39	0017-00005-0203	COIN SWITCH CHUTE
40	0017-00005-0195	COIN SWITCH
41	0010-00599-0000	COIN SWITCH WIRE
42	0017-00007-0132	PUSH-ON RING
	A090-00059-0400	COIN SWITCH & WIRE ASSY. (ITEMS 40 THRU 42)
43	0017-00101-0698	#4-40 x 3/4 SLT. RND. HD. M.S. (2 REQ'D.)
	A090-00077-0000	COIN GUIDE & SWITCH ASSY. (ITEMS 38 THRU 43)

VI Technical Troubleshooting

Introduction

The most common problems occur in harness components such as the coin acceptor, player controls, interconnecting wiring, etc. The TV monitor and PCB computer cause their share of problems too, but not as much as the harness and its component parts. TV monitor troubleshooting will not be covered here because it is covered in that section of this manual.

As you already know, the PCB computer is a complex device with a number of different circuits. Some circuits remain basically the same among games, but overall there are a great many differences between them. PCB troubleshooting procedures, therefore, can be lengthy and will differ greatly among games. However, some basic Z-80 CPU information is involved in this section.

General Suggestions

The first step in any troubleshooting procedure is correctly identifying the malfunction's symptoms. This includes not only the circuits or features malfunctioning, but also those still operational. A carefully trained eye will pick up other clues as well. For instance, a game in which the computer functions fail completely just after money was collected may have a quarter shorting the PCB traces. Often, an experienced troubleshooter will be able to spot the cause of the problem even before opening the cabinet.

After all the clues are carefully considered, the possible malfunctioning areas can be narrowed down to one or two good suspects. Those areas can be examined by a process of elimination until the cause of the malfunction is discovered.

Harness Component Troubleshooting

Typical problems falling in this category are coin and credit problems, power problems and failure of individual features.

NO GAME CREDIT

For example, your prospective player inserts his quarter and is not awarded a game. The first item to check is if the quarter is returned. If the quarter is returned, the malfunction most certainly lies in the coin acceptor itself. First, use a set of test coins (both old and new) to ascertain that the player's coin is not undersize or underweight. If your test coins are also returned, coin acceptor servicing is indicated. Generally, the cause of this particular problem is a maladjusted magnet gate. Normally, this will mean slightly closing the magnet gate a little by turning the adjusting screw out a bit (see section on coin acceptor for more details).

If the quarter is not returned and there is no game credit, the cause of the malfunction may be in one of several areas. First try operating the coin return button; if the coin is returned, the problem is most likely in the magnet gate. Enlarge the gap according to the coin acceptor service procedures. If this does not cure the problem, remove the coin acceptor, clean it and perform the major adjustment procedure.

If the trapped coin is not returned when the wiper lever is actuated, you may have an acceptor jammed by a slug, gummed up with beer, a jammed coin chute, or mechanical failure of the acceptor mechanism. In this case, first check for the slug that will generally be trapped against the magnet. If so, simply remove the slug and test the acceptor. If the chute is blocked, remove the acceptor and remove the jammed coins. If there is actual failure of the acceptor, remove the unit and repair as indicated in the coin acceptor service procedures.

If the coin is making its way through the acceptor (that is, falling into the coin box), yet there is still no game credit, you either have a mechanical failure of the coin switch or electrical failure of the coin and credit circuits. The first place to begin is by checking the coin switch. Most of these switches are the make/break variety of micro switch, which is checked by testing for continuity between the NO, NC, and C terminals. When not actuated, the NC and C terminals should be continuous and the NO terminal open. When operated, the NO and C terminals should close and the NC should be open. If the coin switch checks out, examine the connections to the terminals to make sure there is good contact. If necessary, use the continuity tester and check from the terminal lug on the switch to the associated PCB trace. This will tell you if there is a continuous line all the way to the credit circuit.

If the coin switch wires do not check out, the problem is in the computer — most likely in the coin and credit circuitry.

If you do get game credit when a coin is deposited, but the game will not start when the start switch is pressed, you may have a problem in the start switch, the interconnecting wiring or in the computer. First check the switch. If the switch is OK, proceed to check the wiring. Again, make sure you go from the terminal lug on the switch to the PCB trace. This way, you will check the terminal contact as well as PCB edge connector contact. If the wiring is continuous, proceed to check the PCB credit circuit. If not, check each section of the wiring, until the discontinuity is located. If the wiring is OK, the problem must lie in the computer.

Transformer and Line Voltage Problems

Your machine must have the correct line voltage to operate properly. If the line voltage drops too low, a circuit in the computer will disable game credit. The point at which the computer will fail to work will vary some from game to game, but no game will work on line voltage that drops below 105 VAC.

Low line voltage may have many causes. Line voltage normally fluctuates a certain amount during the day as the total usage varies. Peak usage times occur mainly at dawn or dusk, so if your machine's malfunction seems to be related to the time of day, this may be a factor. A large load connected to the same line as the game (such as a large air conditioner or other device with an exceptionally large motor) may drop the line voltage significantly when starting up. This drop can result in an intermittent credit problem. In addition, poor connections in the location wiring, plug, or line cord may also cause a significant drop in power. Cold solder joints in the game's harness, especially in areas like the transformer connections, interlock switch, or fuse block, may also produce the same results, although probably on a more permanent basis.

Sometimes location owners (especially in bars) replace light switches with dimmer rheostats, and the game is sometimes on the same line. Obviously, the voltage available to the game is going to drop dramatically when the dimmer is turned.

In any case, the way to check for correct line voltage is with your VOM. Set the VOM to 250 VAC and stick the probes in the wall receptacle. If it's OK here, check the transformer primary connections. If you do not get 117 VAC, examine the solder joints on the transformer, fuse block, and interlock switch. If you do get 117 VAC, the problem must be either in the transformer, harness connections, or in the PCB power supply.

If you suspect the transformer, check its secondaries with the VOM set to 50 VAC and correlate the readings with the legend on the side of the transformer. The transformer must also be correctly grounded, so check the ground potential as well, especially if there is a hum bar rolling up or down the TV screen.

HARNESS PROBLEMS

Other harness problems include blowing fuses and malfunctioning controls. The repeating blown-fuse problem can sometimes be quite exasperating to solve, for short circuits have the tendency to occur in areas almost impossible to find. First, try inserting a new fuse, as old fuses age and blow without cause. If the new one also blows, you definitely have a short.

The best way to approach this problem is by turning the power off and disconnecting devices that may be causing the problem, such as the TV, transformer, and PCB. Disconnect the devices by pulling off their connectors, but do not allow them to touch. If necessary, insulate them with small pieces of electrical tape. Then, connect your VOM across the terminals of the fuse block (all electrical power shut off), and set it to one of the resistance scales. This will save blowing a fuse each time you want to check the circuit.

If the VOM reveals that disconnecting the devices removed the short, reconnect the devices one by one until the short returns. The last device connected is the one that is at fault. If the VOM reads a short even after the devices are disconnected, the fault must lie in the harness itself, and only patient exploration will reveal its location. First, carefully examine all the wiring, looking for terminals that may be touching, metal objects such as coins shorting connections or burned insulation. If necessary, use the VOM to check each suspected wire.

MALFUNCTIONING CONTROLS

One of the most common problems here is a bad potentiometer. Typically, a bad pot will cause the image to jump as it reaches a certain point. The only cure for this one is to install a new pot.

If a feature that is operated by a switch (for example, joysticks, foot pedals, control panel buttons) does not operate at all, check the switch with a VOM or continuity tester to verify its operation. If the switch does not check out, replace it. If the switch is OK, you should suspect the input to the switch from the PCB. In this case, get out the harness and logic schematics and check to see what kind of input it is. In many cases, the input will be +5 VDC. If so, use the VOM to check its presence. Normally, the switch is used to pull a +5 VDC line LOW to GND or to pull a LOW line HIGH. If the PCB output is missing, check the wire length from the PCB. If you find the signal at the PCB trace, the wire length or connection is at fault. If not, begin exploring the PCB using the logic schematics.

A Glossary of Microprocessor Terms

MICROPROCESSOR — one or several microcircuits that perform the function of a computer's CPU. Sections of the circuit have arithmetic and comparative functions that perform computations and executive instructions.

CPU — central-processing unit. A computing system's "brain", whose arithmetic, control and logic elements direct functions and perform computations. The microprocessor section of a microcomputer is on one chip or several chips.

PROM — programmable read-only memory. User permanently sets binary on-off bits in each cell by selectively fusing or not fusing electrical links. Non-erasable. Used for low-volume applications.

EPROM — erasable, programmable, read-only memory. Can be erased by ultraviolet light bath, then reprogrammed. Frequently used during design and

development to get programs debugged, then replaced by ROM for mass production.

ROM — read-only memory. The program, or binary on-off bit pattern, is set into ROM during manufacture, usually as part of the last metal layer put onto the chip. Nonerasable. Typical ROM's contain up to 16,000 bits of data to serve as the microprocessor's basic instructions.

RAM — random-access memory. Stores binary bits as electrical charges in transistor memory cells. Can be read or modified through the CPU. Stores input instructions and results. Erased when power is turned off.

LSI — large scale integration. Formation of hundreds or thousands of so-called gate circuits on semiconductor chips. Very large scale integration (VLS) involves microcircuits with the greatest component density.

MOS — metal-oxide semiconductor. A layered construction technique for integrated circuits that achieves high component densities. Variations in MOS chip structures create circuits with speed and low-power requirements, or other advantages (static will damage a MOS chip).

Introduction to the Z-80 CPU

The term "microcomputer" has been used to describe virtually every type of small computing device designed within the last few years. This term has been applied to everything from simple "microprogrammed" controllers constructed out of TTL MSI up to low end minicomputers with a portion of the CPU constructed out of TTL LSI "bit slices." However, the major impact of the LSI technology within the last few years has been with MOS LSI. With this technology, it is possible to fabricate complete and very powerful computer systems with only a few MOS LSI components.

The Zilog Z-80 family of components can be configured with any type of standard semiconductor memory to generate computer systems with an extremely wide range of capabilities. For example, as few as two LSI circuits and three standard TTL MSI packages can be combined to form a simple controller. With additional memory and I/O devices a computer can be constructed with capabilities that only a minicomputer could previously deliver.

New products using the MOS LSI microcomputer are being developed at an extraordinary rate. The Zilog Z-80 component set has been designed to fit into this market through the following factors:

1. The Z-80 is fully software compatible with the popular 8080A CPU.
2. Existing designs can be easily converted to include the Z-80.
3. The Z-80 component set is at present superior in both software and hardware capabilities to any other microcomputer system on the market today.
4. For increased throughput the Z80A operating at a 4 MHz clock rate offers the user significant speed advantages.

Microcomputer systems are extremely simple to construct using Z-80 components. Any such system consists of three parts:

1. **CPU (Central Processing Unit)**
2. **Memory**
3. **Interface Circuits to peripheral devices**

The CPU is the heart of the system. Its function is to obtain instructions from the memory and perform the desired operations. The memory is used to contain instructions and in most cases data that is to be processed. For example, a typical instruction sequence may be to read data from a specific peripheral device, store it in a location in memory, check the parity and write it out to another peripheral device. Note that the Zilog component set includes the CPU and various general purpose I/O device controllers, while a wide range of memory devices may be used from any source. Thus, all required components can be connected together in a very simple manner with virtually no other external logic.

General Purpose Registers

There are two matched sets of general purpose registers, each set containing six 8-bit registers that may be used individually as 8-bit registers or as 16-bit register pairs by the programmer. One set is called BC, DE and HL while the complementary set is called BC', DE' and HL'. At any one time the programmer can select either set of registers to work with through a single exchange command for the entire set. In systems where fast interrupt response is required, one set of general purpose registers and an accumulator/flag register may be reserved for handling this very fast routine. Only a simple exchange command need be executed to go between the routines. This greatly reduces interrupt service time by eliminating the requirement for saving and retrieving register contents in the external stack during interrupt or subroutine processing. These general purpose registers are used for a wide range of applications by the programmer. They also simplify programming, especially in ROM based systems where little external read/write memory is available.

Arithmetic & Logic Unit (ALU)

The 8-bit arithmetic and logical instructions of the CPU are executed in the ALU. Internally the ALU communicates with the registers and the external

data bus on the internal data bus. The type of functions performed by the ALU include:

Add	Left or right shifts or rotates (arithmetic and logical)
Subtract	Increment
Logical AND	Decrement
Logical OR	Set bit
Logical Exclusive OR	Reset bit
Compare	Test bit

Instruction Register and CPU Control

As each instruction is fetched from memory, it is placed in the instruction register and decoded. The control sections performs this function and then generates and supplies all of the control signals necessary to read or write data from or to the registers, control the ALU and provide all required external control signals.

Z-80 CPU Pin Description

The Z-80 CPU is packaged in an industry standard 40 pin Dual in-Line Package. The I/O pins are shown in the below figure and the function of each is described.

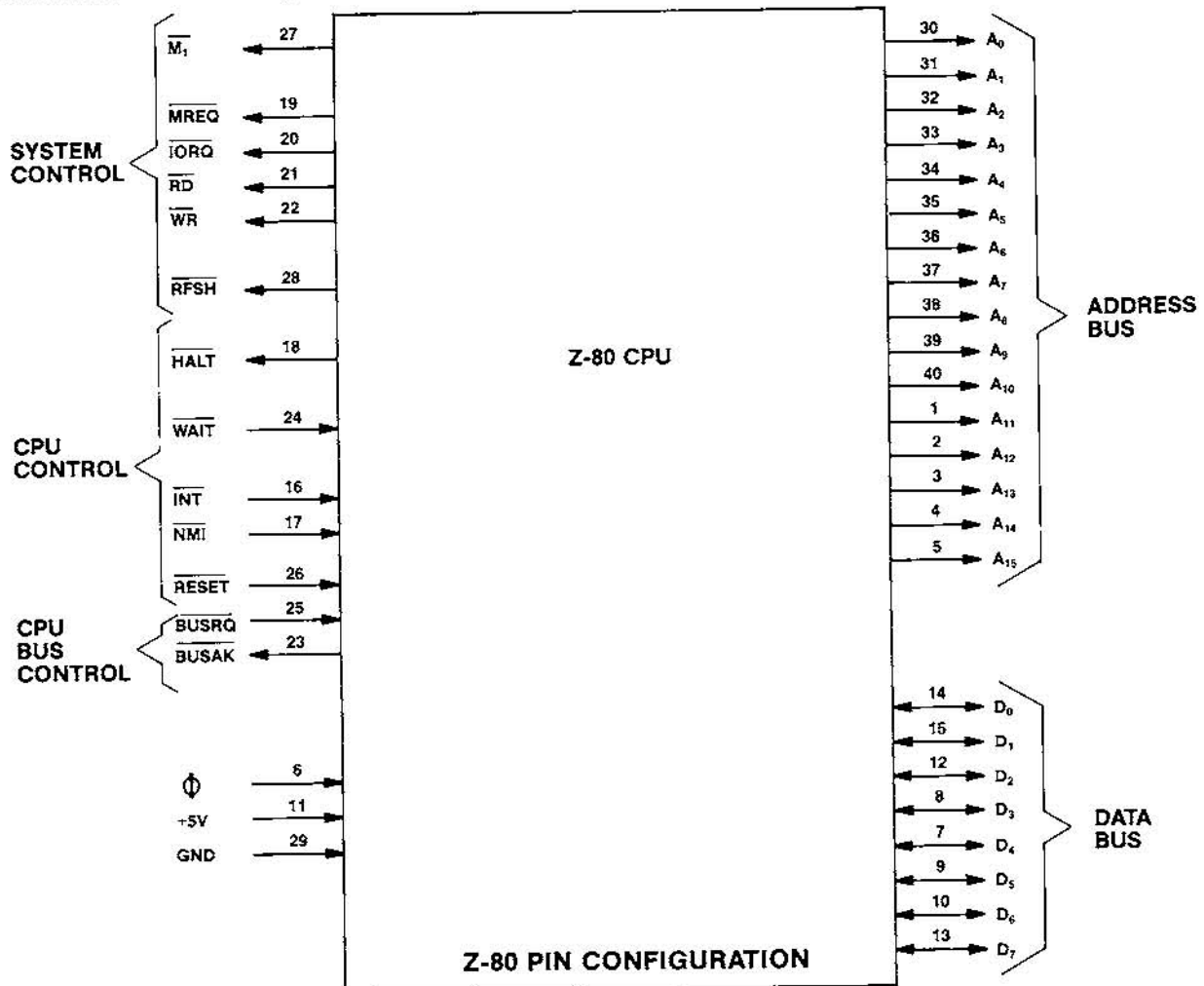

A₀-A₁₅**(Address Bus)**

Tri-state output, active high. A₀-A₁₅ constitute a 16-bit address bus. The address bus provides the address for memory (up to 64K bytes) data exchanges and for I/O device data exchanges. I/O addressing uses the 8 lower address bits to allow the user to directly select up to 256 input or 256 output ports. A₀ is the least significant address bit. During refresh time, the lower 7 bits contain a valid refresh address.

D₀-D₇**(Data Bus)**

Tri-state input/output, active high. D₀-D₇ constitute an 8-bit bidirectional data bus. The data bus is used for data exchanges with memory and I/O devices.

M₁**(Machine Cycle one)**

Output, active low. M₁ indicates that the current machine cycle is the OP code fetch cycle of an instruction execution. Note that during execution of 2-byte op-codes, M₁ is generated as each op code byte is fetched. These two byte op-codes always begin with CBH, DDH, EDH or FDH. M₁ also occurs with IORQ to indicate an interrupt acknowledge cycle.

MREQ**(Memory Request)**

Tri-state output, active low. The memory request signal indicates that the address bus holds a valid address for a memory read or memory write operation.

IORQ**(Input/Output Request)**

Tri-state output, active low. The IORQ signal indicates that the lower half of the address bus holds a valid I/O address for a I/O read or write operation. An IORQ signal is also generated with an M₁ signal when an interrupt is being acknowledged to indicate that an interrupt response vector can be placed on the data bus. Interrupt Acknowledge operations occur during M₁ time while I/O operations never occur during M₁ time.

RD**(Memory Read)**

Tri-state output, active low. RD indicates that the CPU wants to read data from memory or an I/O device. The addressed I/O device or memory should use this signal to gate data onto the CPU data bus.

WR**(Memory Write)**

Tri-state output, active low. WR indicates that the CPU data bus holds valid data to be stored in the addressed memory or I/O device.

RFSH**(Refresh)**

Output, active low. RFSH indicates that the lower 7 bits of the address bus contain a refresh address for dynamic memories and the current MREQ signal should be used to do a refresh read to all dynamic memories.

HALT**(Halt state)**

Output, active low. HALT indicates that the CPU has executed a HALT software instruction and is awaiting either a non maskable or a maskable interrupt (with the mask enabled) before operation can resume. While halted, the CPU executes NOP's to maintain memory refresh activity.

WAIT**(Wait)**

Input, active low. WAIT indicates to the Z-80 CPU that the addressed memory or I/O devices are not ready for a data transfer. The CPU continues to enter wait states for as long as this signal is active. This signal allows memory or I/O devices of any speed to be synchronized to the CPU.

INT**(Interrupt Request)**

Input, active low. The Interrupt Request signal is generated by I/O devices. A request will be honored at the end of the current instruction if the internal software controlled interrupt enable flip-flop (IFF) is enabled and if the BUSRQ signal is not active. When the CPU accepts the interrupt, an acknowledge signal (IORQ during M₁ time) is sent out at the beginning of the next instruction cycle. The CPU can respond to an interrupt in three different modes that are described in detail in section 5.4 (CPU Control Instructions).

NMI**(Non-Maskable Interrupt)**

Input, negative edge triggered. The non maskable interrupt request line has a higher priority than INT and is always recognized at the end of the current instruction, independent of the status of the interrupt enable flip-flop. NMI automatically forces the Z-80 CPU to restart to location 0066H. The program counter is automatically saved in the external stack so that the user can return to the program that was interrupted. Note that continuous WAIT cycles can prevent the current instruction from ending, and that a BUSRQ will override a NMI.

RESET

Input, active low. RESET forces the program counter to zero and initializes the CPU. The CPU initialization includes:

- 1) Disable the interrupt enable flip-flop

- 2) Set Register I = 00H
- 3) Set Register R = 00H
- 4) Set Interrupt Mode 0

During reset time, the address bus and data bus go to a high impedance state and all control output signals go to the inactive state.

BUSRQ

(Bus Request)

Input, active low. The bus request signal is used to request the CPU address bus, data bus and tri-state output control signals to go to a high impedance state so that other devices can control these buses. When BUSRQ is activated, the CPU will set these

buses to a high impedance state as soon as the current CPU machine cycle is terminated.

BUSAK

(Bus Acknowledge)

Output, active low. Bus acknowledge is used to indicate to the requesting device that the CPU address bus, data bus and tri-state control bus signals have been set to their high impedance state and the external device can now control these signals.

CLK

(Clock)

Single phase TTL level clock which requires only a 330 ohm pull-up resistor to +5 volts to meet all clock requirements.

IX Schematics and Wiring Diagrams

LAZARIAN GAME LOGIC BOARD DEVICES

(P.C. A084-91419-C636)

Chip Number	Function	Chip Number	Function
74LS00	Quad 2 Input NAND	74LS174	Hex D Type Flip-Flop
74LS02	Quad 2 Input NOR	74LS244	Octal Buffer — Tri State
74LS04	Hex Inverter	74LS245	
7406	Hex Inverter Buffers/Drivers	or 8T245	Octal Bus Transceiver
74LS08	Quad 2 Input AND	74LS283	4 Bit Binary Full Adder
74LS10	Triple 3 Input NAND	74LS373	Octal D Type Latches — Common Enable
74LS14	Hex Schmitt-Trigger Inverters	74LS374	Octal D Type Flip-Flop — Common Clock
74LS21	Dual 4 Input AND	2650	8 Bit CPU
74LS26	Quad 2 Input NAND — High Voltage	2732	4K x 8 EPROM
74LS27	Triple 3 Input NOR	2716	2K x 8 EPROM
74LS32	Quad 2 Input OR	2636	Programmable Video Interface
74LS74	Dual D Type Flip-Flop	2114	1K x 4 RAM
74LS85	4 Bit Magnitude Comparator	N82S100	Field Programmable Logic Array
74LS86	Quad 2 Input Exclusive — OR	2621	Universal Sync. Generator
74LS90	Decade Counter	CA3081	Transistor Array — NPN
74LS112	Dual J-K Flip-Flop	40097	Hex Buffer — Tri State — CMOS
74LS125	Quad Buffer — Tri State		
74LS139	Dual 2 to 4 Line Decoder		
74LS155	Decoder/Demultiplexer — Totem Pole		ADDITIONAL DEVICES
74LS156	Decoder/Demultiplexer — Open Collector	14.318	Xtal
74LS157	Quad 2 to 1 Line Multiplexer	BC548	NPN Transistor
74LS161	4 Bit Binary Counter	BC337	NPN Transistor
74LS164	8 Bit Parallel Output Shift Register	1N4148	Diode
74166	8 Bit Shift Register Parallel/Serial Input	1N4004	Diode

LAZARIAN SOUND BOARD DEVICES

(P.C. A084-90911-E636)

Chip Number	Function
74S04	Hex Inverters
7406	Hex Inverters Buffers/Drivers
74LS156	Decoder/Demultiplexer — Open Collector
74LS161	4 Bit Binary Counter
74LS374	Octal D Type Flip-Flops
4016	Quad Bilateral Switches — CMOS
TMS3615	Organ Tone Generator
SN76477	Complex Sound Generator
TDA 1010A	6 Watt Audio Power Amplifier
4.0000	Xtal
BC557	Transistor PNP
1N4148	Diode
1N4004	Diode

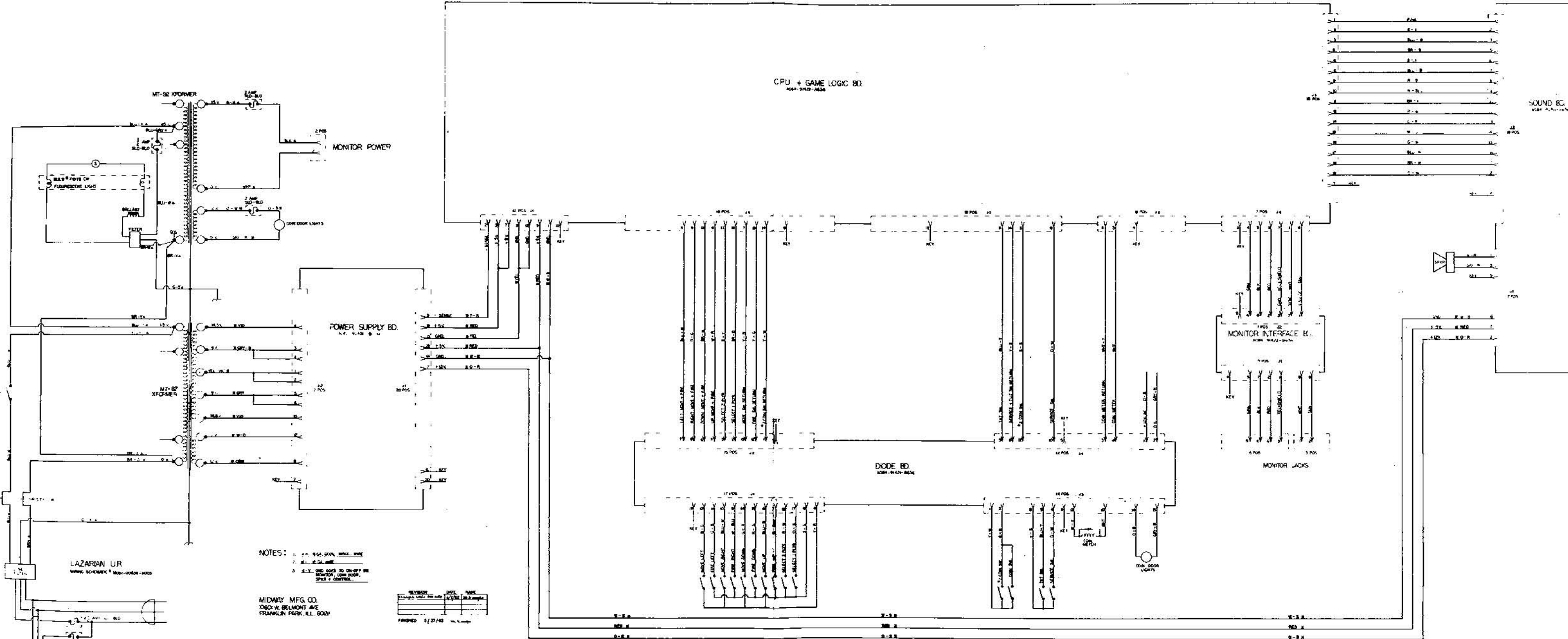

CPU + GAME LOGIC BD.
4064-1917-1636

POWER SUPPLY BD.
A.T. 1-18-61

DIODE BD.
4064-1942-1636

MONITOR INTERFACE BD.
4064-1942-1636

SOUND BD.
4064-1942-1636

LAZARIAN UR
WIRE SCHEMATIC 1 Rep. 0004-1002

- NOTES:
- 1. 2. 3. 4. 5. 6. 7. 8. 9. 10. 11. 12. 13. 14. 15. 16. 17. 18. 19. 20. 21. 22. 23. 24. 25. 26. 27. 28. 29. 30. 31. 32. 33. 34. 35. 36. 37. 38. 39. 40. 41. 42. 43. 44. 45. 46. 47. 48. 49. 50. 51. 52. 53. 54. 55. 56. 57. 58. 59. 60. 61. 62. 63. 64. 65. 66. 67. 68. 69. 70. 71. 72. 73. 74. 75. 76. 77. 78. 79. 80. 81. 82. 83. 84. 85. 86. 87. 88. 89. 90. 91. 92. 93. 94. 95. 96. 97. 98. 99. 100.

MIDWAY MFG. CO.
1000 W. BELMONT AVE.
FRANKLIN PARK, ILL. 60061

| REVISION | DATE | NAME |
|----------|------|------|
| | | |
| | | |
| | | |

FINISHED 5/27/62

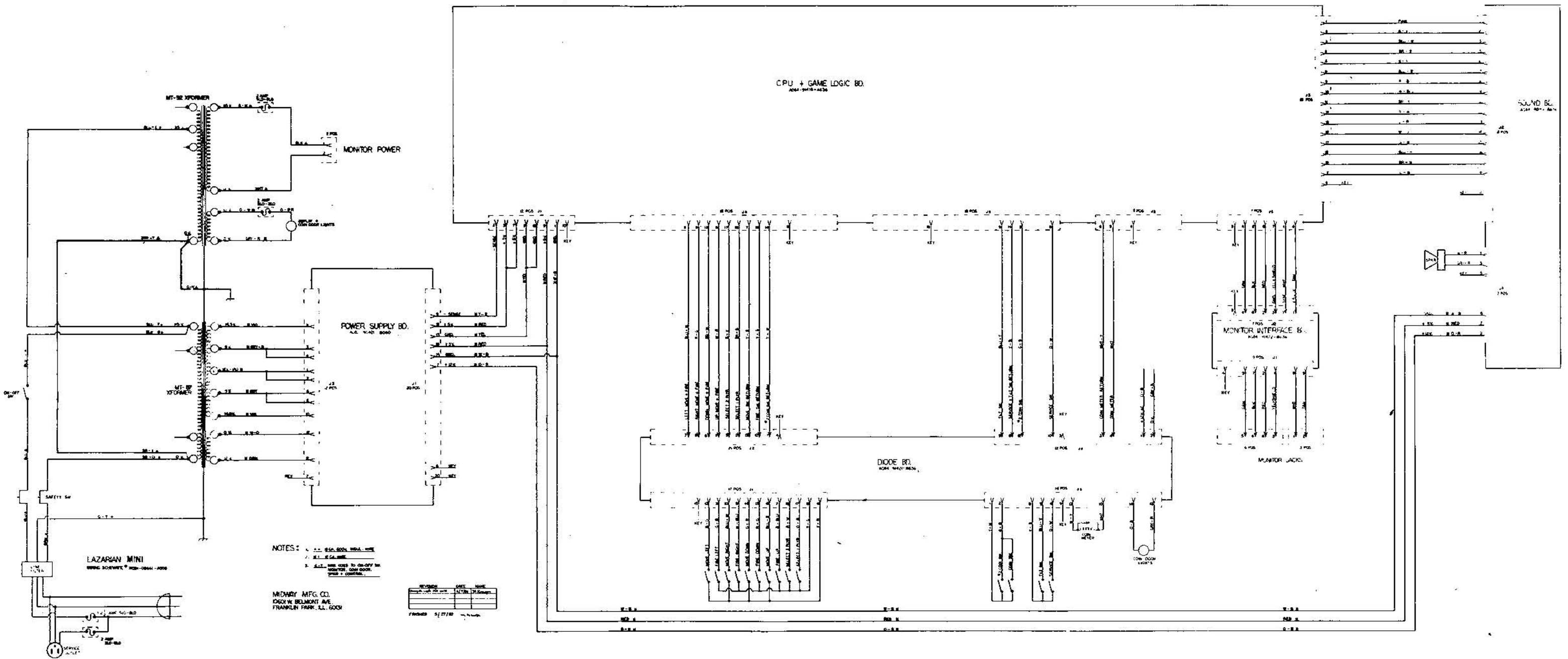

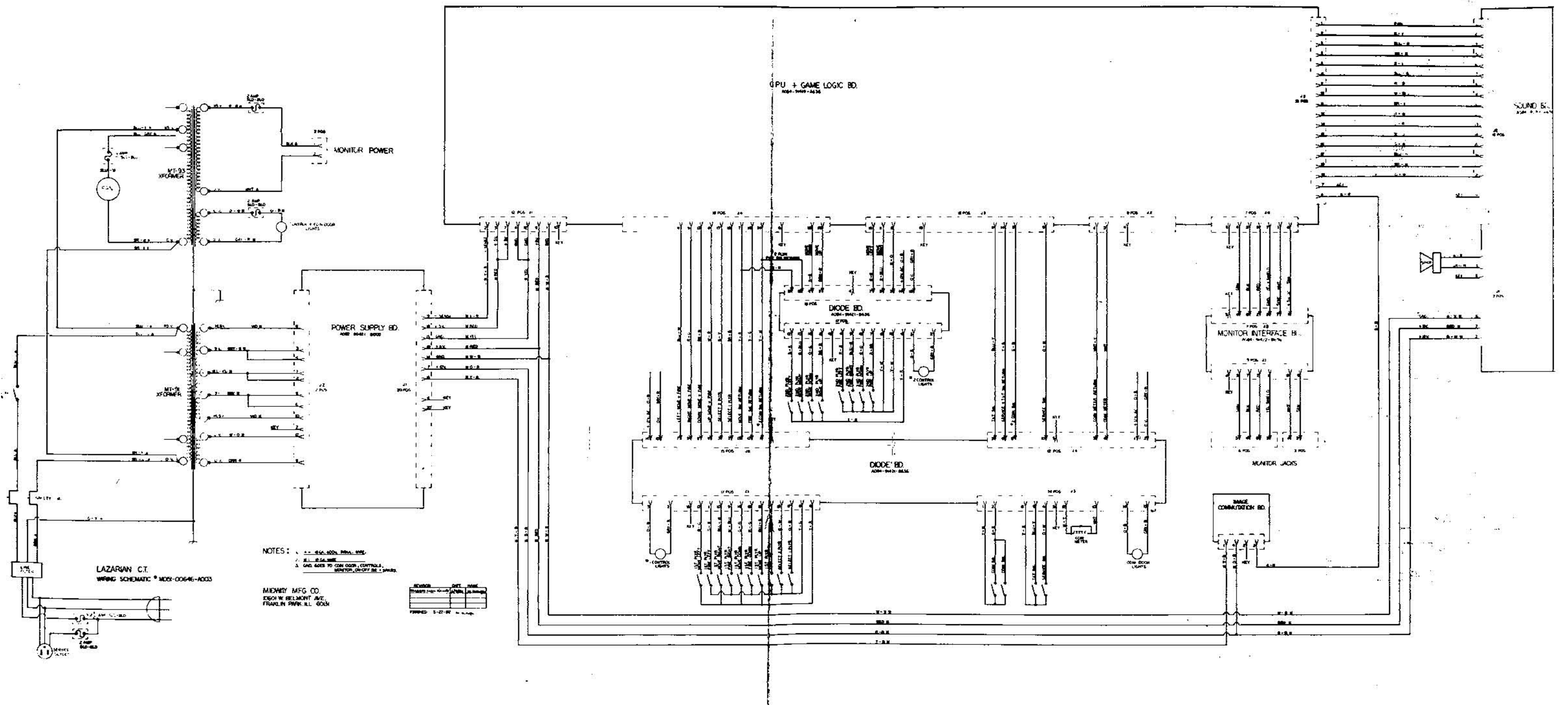

NOTES:
 1. ALL RESISTORS ARE 1/4W 5% TOL.
 2. ALL CAPS ARE 50V UNLESS NOTED OTHERWISE.
 3. GND AGES TO CASE DOOR CONTROLS.
 4. MONITOR CHECK SW 1 SW2.

MIDWAY MFG CO.
 2500 W. BELMONT AVE.
 FRANKLIN PARK, ILL. 60066

| REVISED | DATE | BY |
|---------|------|----|
| | | |
| | | |
| | | |

FORMED: 3-27-67

LAZARUS CT.
 WIRING SCHEMATIC # 4041-0046-0003

DESIGNATION LIST

| DESIGNATION | DESCRIPTION | DESIGNATION | DESCRIPTION | DESIGNATION | DESCRIPTION |
|-------------|----------------------|-----------------------------------|-----------------------|---------------|---------------------------|
| C100 | 10mf RD TANT | R126 | 10 OHM 1/4W 5% CRB | HSA1 | HEATSINK ASSY. |
| C101 | 0.47mf RD TANT 35V | R127 | 1K " | MHSA | HEATSINK ASSY MTO MI HW |
| C102 | 470mf AX ELEC | R128 | 8.2K " | | 2-4-40 X 10 SLT RND |
| | | R129 | 1K " | | 4- WASHER, 4, 120-250 O18 |
| C104 | 25,000mf AX ELEC | | | | 2-4-40 HEX NUT |
| C105 | 4.7mf RD TANT 35V | R132 | 150 OHM 2W 10% | | THERMAL COMPOUND |
| C106, C107 | 0.1mf | R134 | 68 OHM 1/2W 5% | | |
| C111 | 0.1mf | | | | |
| C113 | 40,000mf AX ELEC | | | | |
| C114 | 470mf AX ELEC | | | | |
| C115 | 2200mf AX ELEC 25V | | | | |
| C116 | 4700mf AX ELEC 25V | VR100, VR101, VR102 | 100 OHM POT | | |
| C117 | 47pf | | | | |
| C118 | 0.1mf | | | | |
| C121 | 0.1mf | D100, D101, D102 | 1N4148 | F1 | FUSE, 1/4A SLO-BLO |
| | | D103 | 1N4001 | F2 | FUSE, 1AMP |
| | | D106, D107 | MR750 | F1, F2 | FUSE CLIP W/STOP |
| | | D108, D109 | 1N4001 | | |
| | | D10, D11, D12, D13, D14, D15, D16 | A15F 50V 5A | | |
| R100 | 100 OHM 1/4W 5% CRB | | | J1 | 2 POS KK-156 |
| R101 | 470 " | | | J1, J2 | 5 POS " |
| R102 | 0.18 OHM 5W 5% | | | J1 | 13 POS " |
| R103 | 0.16 OHM 15W 5% | Q100, Q101 | 2N5772 | J2 | 6 POS " |
| R104 | 68 OHM 1/2W 5% CRB | Q102, Q104 | 2N2905 | | |
| R105 | 24 OHM 1/4W 5% CRB | | | | |
| R106 | 270 " | | | | |
| | | U2 | LM305 | JW1, JW2, JW3 | JUMPER WIRE |
| | | U5 | LM305 | | |
| R113 | 1.2K OHM 1/4W 5% CRB | | | TW1, TW2 | TIE WRAP |
| R114 | 560 " | | | TW3, TW4 | TIE WRAP |
| | | | | LB1 | TAG, FUSE 1/4A SLO-BLO |
| R120 | 1.2K OHM 1/4W 5% CRB | FBI, FB2 | FERRITE BEAD | LB2 | TAG, FUSE 1AMP |
| | | FBNH1, FBNH2 | FERRITE BEAD MTO HORN | LB3 | TAG, PWR SPLY I.D. |
| R124 | 25 OHM 5W 10% | | | | |
| R125 | 68 OHM 1/2W 5% CRB | | | | |

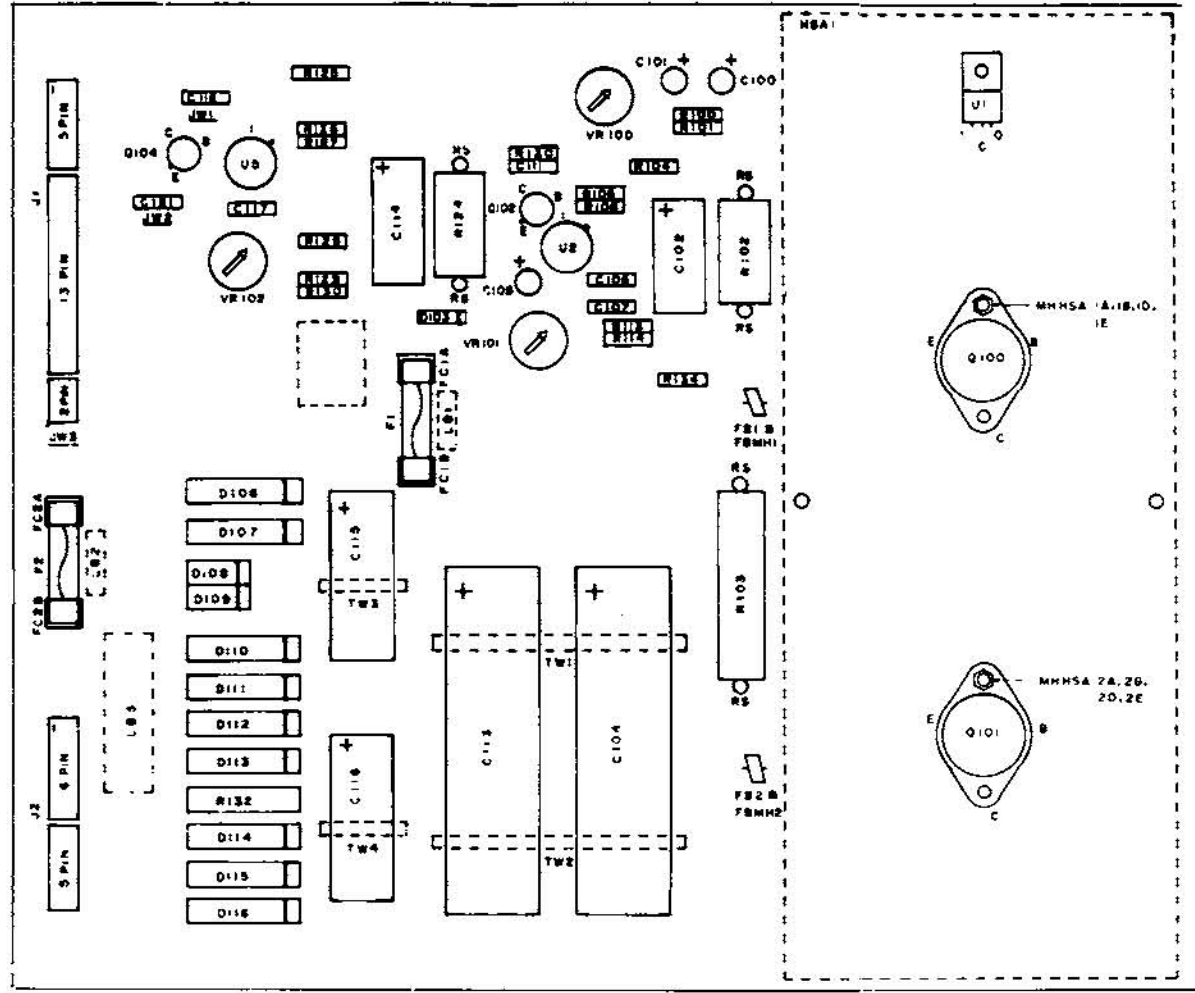

CROSS REFERENCE LIST

| DESCRIPTION | QTY | DESIG. NOS. | PART NOS. |
|------------------------|-----------|--------------------------------------|-----------------|
| 47 pf | 1 | C117 | 0945-00811-0100 |
| 0.1mf | 5 | C106, C107, C111
C118, C121 | 0945-00811-0200 |
| 0.47mf RD TANT 35V | 1 | C101 | 0945-00816-1100 |
| 4.7mf RD TANT 35V | 1 | C105 | 0945-00811-0400 |
| 10mf RD TANT | 1 | C100 | 0945-00816-1000 |
| 470mf AX ELEC. | 2 | C102, C114 | 0945-00816-0800 |
| 2200mf AX ELEC 25V | 1 | C115 | 0945-00816-1300 |
| 4700mf AX ELEC 25V | 1 | C116 | 0945-00813-0700 |
| 25000mf AX ELEC | 1 | C104 | 0945-00818-1700 |
| 40000mf AX ELEC. | 1 | C113 | 0945-00816-1800 |
| 16 OHM 15W 5% | 1 | R103 | 0945-00815-0100 |
| 18 " 5W 5% | 1 | R102 | 0945-00815-0200 |
| 10 " 1/4W 5% CRB | 1 | R126 | 0062-051B3-1XXX |
| 24 " " | 1 | R105 | 0062-065B3-1XXX |
| 25 " 5W 10% | 1 | R124 | 0945-00815-1000 |
| 68 " 1/2W 5% | 3 | R104, R125, R134 | 0062-098D3-1XXX |
| 100 " 1/4W 5% CRB | 1 | R100 | 0062-098D3-1XXX |
| 150 " 2W 10% | 1 | R132 | 0945-00812-0200 |
| 270 " 1/4W 5% | 1 | R106 | 0062-138B3-1XXX |
| 470 OHM 1/4W 5% | 1 | R101 | 0062-156B3-1XXX |
| 560 " " | 1 | R114 | 0062-162B3-1XXX |
| 1K " " | 2 | R127, R129 | 0062-179B3-1XXX |
| 12K " " | 2 | R113, R120 | 0062-183B3-1XXX |
| 6.2K OHM 1/4W 5% | 1 | R128 | 0062-217B3-1XXX |
| 100 OHM POT | 3 | VR100, VR101,
VR102 | 0945-00814-0000 |
| A15F 50V 5A DIODE | 7 | D10, D11, D12, D13,
D14, D15, D16 | 0945-00804-0200 |
| 1N4001 | 3 | D103, D106, D109 | 0945-00804-0300 |
| MR 750 | 2 | D106, D107 | 0945-00804-0800 |
| 2N2905 | 2 | Q102, Q104 | 0945-00808-0300 |
| 2N3772 | 2 | Q100, Q101 | 0945-00808-0100 |
| LM305 | 2 | U2, U5 | 0945-00813-0100 |
| FERRITE BEAD | 2 | FBI, FB2 | 0017-00009-0225 |
| FERRITE MTG HARDWARE | 2 | FBNH1, FBNH2 | 0017-00033-0139 |
| 20G SOLID WIRE | 2 | FBNH1, FBNH2 | 0017-00033-0139 |
| HEAT SINK ASSY | 1 | HSA1 | A945-00008-0100 |
| HEAT SINK MTG HARDWARE | 1 | MHSA | |
| 4-40 X 10 SLT RND | 2 | HSA1 | 0017-00101-0727 |
| WSH, 4, 120-250-O18 | 4 | HSA1 | 0017-00104-0071 |
| 4-40 HEX NUT | 2 | HSA1 | 0017-00103-0002 |
| THERMAL COMPOUND | BASE REQD | HSA1 | 0017-00009-0204 |
| FUSE, 1/4A SLO-BLO | 1 | F1 | 0017-00003-0446 |
| FUSE, 1AMP | 1 | F2 | 0017-00003-0001 |
| FUSE CLIP W/STOP | 4 | F1, F2 | 0017-00003-0214 |
| 2 POS KK-156 CONN | 1 | J1 | 3000-16387-0200 |
| 5 POS " " | 2 | J1, J2 | 3000-16387-0500 |
| 6 POS " " | 1 | J2 | 3000-16387-0600 |
| 13 POS " " | 1 | J1 | 3000-16387-1300 |
| 22 AWG 2 1/2 IN | 3 | JW1, JW2, JW3 | 0151-00087-0000 |
| TIE WRAP 7/8 IN | 2 | TW3, TW4 | 0945-00814-0300 |
| TIE WRAP 10 3/4 IN | 2 | TW1, TW2 | 0945-00814-0400 |
| TAG, FUSE 1/4A SLO-BLO | 1 | LB1 | M051-00945-A020 |
| TAG, FUSE 1AMP | 1 | LB2 | M051-00945-A021 |
| TAG, PWR SPLY I.D. | 1 | LB3 | M051-00945-A022 |
| 70 VA PWR SPLY P.C | 1 | | A080-90421-C000 |

PROJ ENG: J. JARON

| | | | |
|-------------------------|---------------|-----------------|------------------|
| DO NOT SCALE DRAWING | DATE: 6/22/82 | BY: J. JARON | APP: [Signature] |
| FULL SCALE (ONE) PER | | MIDWAY MFG. CO. | |
| ASSEMBLY DRAWING MEDIUM | | 70VA PWR SUPPLY | |
| A082-90421-C000 | | M051-00945-A031 | |

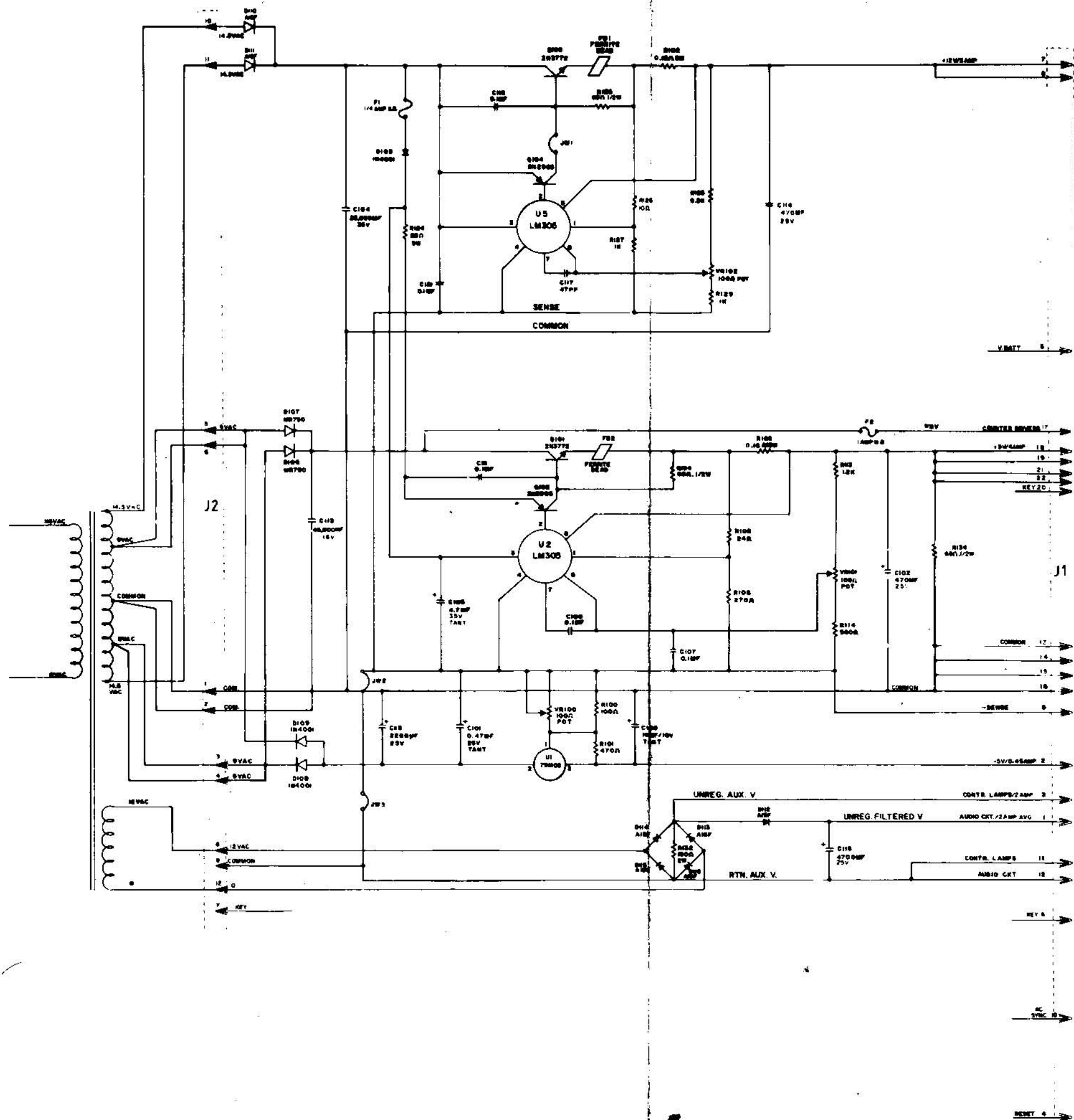

| | | | | | | | |
|---------------------------|--|---------------|------|-----------------|----------|--------------------------|---------|
| REVISED SCALE 50% | | DATE | NONE | DESIGNED BY | LAZARIAN | DATE | 6/22/62 |
| MEDIUM POWER SUPPLY 70 VA | | NO. OF SHEETS | 1 | MIDWAY MFG. CO. | | PART NO. MO51-00945-A032 | |
| A082-90421-0000 | | | | | | | |

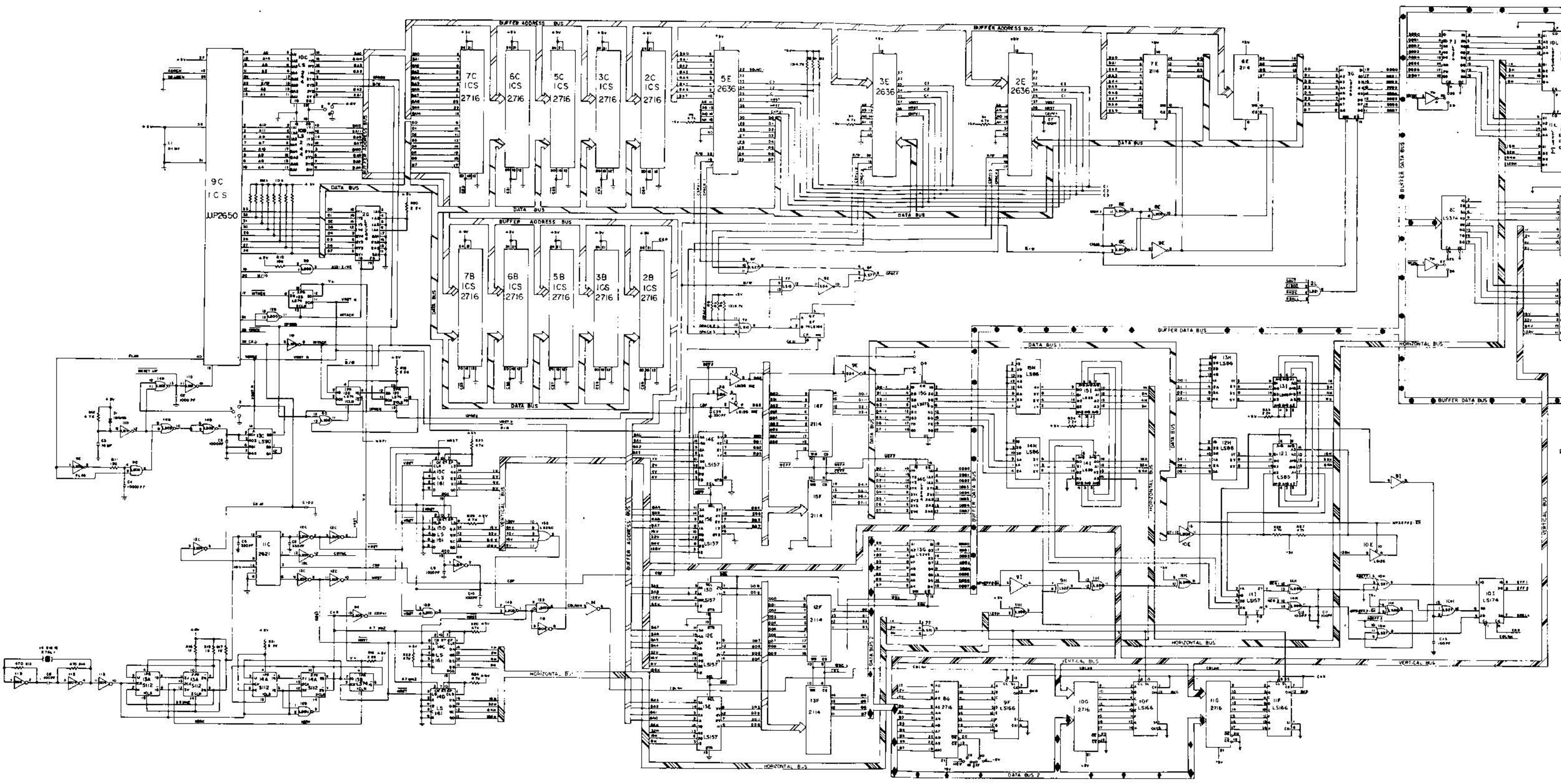

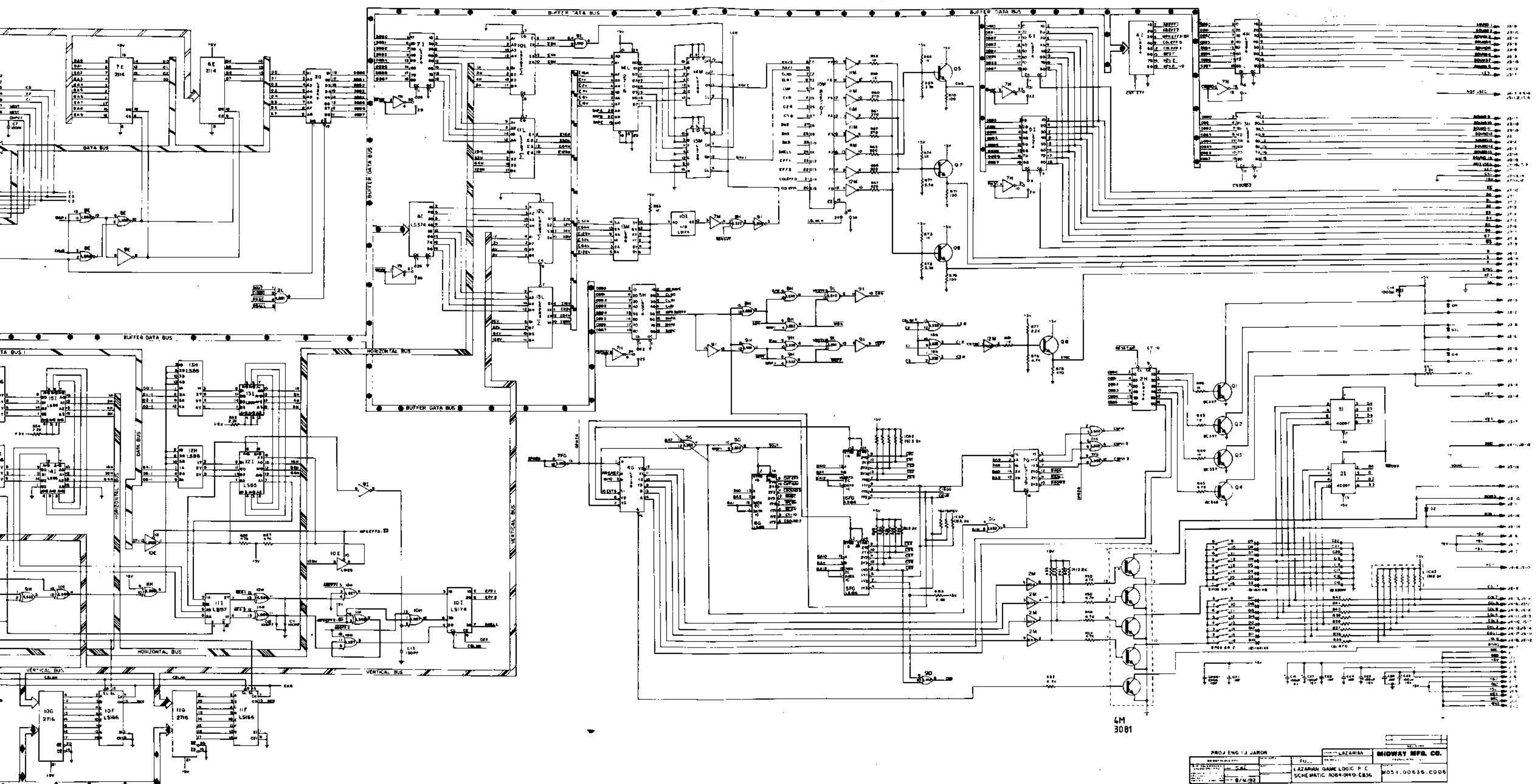

| | | |
|--------------------|-------------------------|-----------------|
| PROJ ENG: J. JARON | LAZARUS | MIDWAY MFG. CO. |
| DATE: 8/11/52 | LAZARUS GAME LOGIC P.C. | MD51-00635-0006 |
| REV: 1 | SCHEMATIC 408-949-0836 | |

DESIGNATION LIST

| DESIGNATION | DESCRIPTION | DESIGNATION | DESCRIPTION |
|-------------|-------------------|-------------|---------------------|
| C1-C4 | 1MF CER. DISC. | U1 | TDA 1010 |
| C5 | 100MF AX. ELEC. | U3 | 76477 |
| C6 | 1MF CER. DISC. | U4-U5 | TMS 3615 |
| C7 | 1000PF CER. DISC. | U6 | 74S04 |
| C8 | 1000MFRD. ELEC. | U7 | 74LS161 |
| C9 | 1MF CER. DISC. | U8 | 74LS156 |
| C10 | 1000MFRD. ELEC. | U9-U15 | 7408 |
| C13 | 100MF AX. ELEC. | U14 | 4018 |
| C14 | 1MF CER. DISC. | U15-U16 | 74LS156 |
| C15 | 330PF CER. DISC. | U17-U20 | 74LS374 |
| C16 | 8-8MF TANT. | | |
| C17 | 10MF TANT. | MHHS | HEATSINK |
| C18 | 01MF CER. DISC. | ICSU3-U5 | 28 PIN IC SOCKET |
| C19 | 1MF CER. DISC. | J2 | 2 PIN CONNECTOR |
| C20 | 01MF CER. DISC. | J3 | 3 " |
| C21 | 1000PF CER. DISC. | J1 | 4 " |
| C22 | 047MF POLY. | J4 | 14 " |
| C23 | 1MF CER. DISC. | JW1-JW3 | JUMPER WIRE |
| C24 | 4.7MF TANT. | JW4 | " |
| C25 | 1MF CER. DISC. | MHHS | HEATSINK MTG. HRDW. |
| C26 | 10MF TANT. | MHHS | SCREW, 5-40 X 6 |
| C27-C28 | 1MF CER. DISC. | MHHS | WSH 6-145-313-019 |
| C29 | 1MF RD. TANT. | MHHS | NUT, 5-40 HET |
| C30 | 1MF CER. DISC. | MHHS | HEATSINK COMPOUND |
| C31 | 1000MFRD. ELEC. | AS REQ. | |
| C32-C39 | 1MF CER. DISC. | XTAL1 | 4MHZ CRYSTAL |
| C40 | 01MF CER. DISC. | MHI-MH4 | SNAPBUSHINGS, 1/8 |
| R1 | 100K OHM 1/4W 5% | | |
| R5 | 33K " | | |
| R6 | 10K " | | |
| R7 | 1K " | | |
| R8-R9 | 6.8K " | | |
| R10-R11 | 1K " | | |
| R12 | 4.7 " | | |
| R13 | 330K " | | |
| R14-R15 | 470 " | | |
| R16-R17 | 4.7K " | | |
| R18-R19 | 2.2K " | | |
| R20-R21 | 47K " | | |
| R22 | 4.7K " | | |
| R23 | 220K " | | |
| R24 | 150K " | | |
| R25 | 120K " | | |
| R26 | 33K " | | |
| R27 | 47K " | | |
| R28 | 68K " | | |
| R29 | 82K " | | |
| R30 | 270K " | | |
| R31 | 6.8K " | | |
| R33 | 1K " | | |
| R34-R35 | 4.7K " | | |
| R36 | 10K " | | |
| R37-R39 | 4.7K " | | |
| R40 | 27K " | | |
| R41 | 22K " | | |
| R42 | 15K " | | |
| R43 | 4.7K " | | |
| R44 | 6.8K " | | |
| R45 | 8.2K " | | |
| R46 | 12K " | | |
| R47 | 47K " | | |
| R48 | 10K " | | |
| R49 | 1K " | | |
| R50 | 47K " | | |
| R51 | 12K " | | |
| R52-R53 | 22K " | | |
| R54 | 27K " | | |
| R55-R79 | 1K " | | |
| R80 | 3.9K " | | |
| R81 | 22K " | | |
| R82 | 10K " | | |
| R83 | 6.8K " | | |
| VR1 | 10K POT. | | |
| D1-D2 | 1N4148 | | |
| D3-D4 | 1N4004 | | |
| D5 | 1N4148 | | |
| Q1 | BC 557 | | |

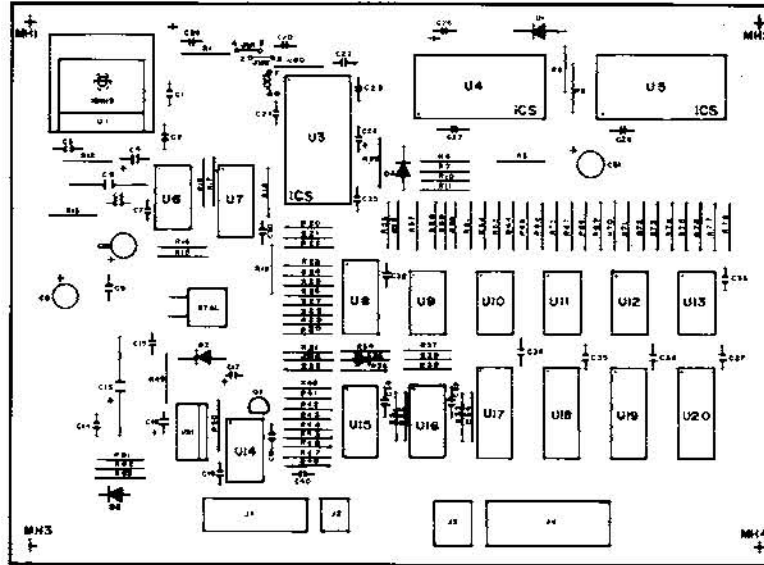

CROSS REFERENCE LIST

| DESCRIPTION | QUANTITY | DESIGNATION | PART NOS. |
|---------------------|----------|---|-----------------|
| 330pf CER. DISC. | 1 | C15 | 0636-00800-0900 |
| 1000pf " | 2 | C7,C21 | 0636-00800-1000 |
| .01mf " | 3 | C18,C20,C40 | 0636-00800-1100 |
| .047mf POLY. | 1 | C22 | 0636-00800-1200 |
| 1mf CER. DISC. | 21 | C1-C4,C6,C9,
C14,C19,C23,C25,
C27,C28,C30,
C32-C39 | 0636-00800-1300 |
| 1mf 50 TANT | 1 | C29 | 0636-00800-1500 |
| 4.7mf TANT | 1 | C24 | 0636-00800-1400 |
| 6.8mf " | 1 | C16 | 0636-00800-1600 |
| 10mf " | 2 | C17,C26 | 0636-00800-1700 |
| 100mf AX. ELECT. | 2 | C5,C13 | 0636-00800-1800 |
| 1000mfrd. ELECT. | 3 | C8,C10,C31 | 0636-00800-1900 |
| 4.7 OHM 1/4W 5% | 1 | R12 | 0062-04283-1XXX |
| 470 " | 2 | R14,R15 | 0062-15683-1XXX |
| 1K " | 30 | R7,R10,R11 | 0062-17983-1XXX |
| 2.2K " | 2 | R33,R40,R55-R79 | |
| 3.9K " | 1 | R18,R19 | 0062-19683-1XXX |
| 4.7K " | 9 | R80 | 0062-20783-1XXX |
| 6.8K " | 5 | R16,R17,R22,
R34-R35,R37-R39,
R43 | 0062-2183-1XXX |
| 8.2K " | 1 | R8,R9,R31,R44,R83 | 0062-21983-1XXX |
| 10K " | 4 | R45 | 0062-22383-1XXX |
| 12K " | 1 | R6,R36,R48,R82 | 0062-22783-1XXX |
| 15K " | 2 | R46,R51 | 0062-23183-1XXX |
| 22K " | 4 | R42 | 0062-23583-1XXX |
| 27K " | 2 | R41,R52,R53,R81 | 0062-24383-1XXX |
| 33K " | 2 | R40,R54 | 0062-24783-1XXX |
| 47K " | 5 | R5,R26 | 0062-25183-1XXX |
| 68K " | 1 | R20,R21,R27,R47,R50 | 0062-25983-1XXX |
| 82K " | 1 | R28 | 0062-26783-1XXX |
| 100K " | 1 | R29 | 0062-27183-1XXX |
| 120K " | 1 | R1 | 0062-27583-1XXX |
| 150K " | 1 | R25 | 0062-27983-1XXX |
| 220K " | 1 | R24 | 0062-28383-1XXX |
| 270K " | 1 | R23 | 0062-29183-1XXX |
| 330K " | 1 | R30 | 0062-29583-1XXX |
| 4018 | 1 | U14 | 0636-00803-3900 |
| 74S04 | 1 | U6 | 0636-00803-4400 |
| 7408 | 5 | U9-U13 | 0636-00803-4100 |
| 74LS156 | 3 | U8,U15,U16 | 0636-00803-4200 |
| 74LS161 | 1 | U7 | 0636-00803-4300 |
| 74LS374 | 4 | U17-U20 | 0636-00803-4000 |
| 76477 | 1 | U3 | 0636-00803-4600 |
| TDA 1010 | 1 | U1 | 0636-00803-4700 |
| TMS 3615 | 2 | U4,U5 | 0636-00803-4500 |
| 10K POT | 1 | VR1 | 0636-00805-3500 |
| 1N4004 | 2 | D3,D4 | 0636-00801-0300 |
| 1N4148 | 3 | D1,D2,D5 | 0636-00801-0400 |
| BC557 | 1 | Q1 | 0636-00802-0300 |
| 4MHZ | 1 | XTAL | 0636-00804-1900 |
| HEATSINK | 1 | MHHS | 0636-00804-2000 |
| 28 PIN IC SOCKET | 3 | ICSU3-U5 | 0636-00804-1800 |
| 2 PIN CONNECTOR | 1 | J2 | 0636-00804-1400 |
| 3 " | 1 | J3 | 0636-00804-1500 |
| 4 " | 1 | J1 | 0636-00804-1600 |
| 14 " | 1 | J4 | 0636-00804-1700 |
| JUMPER WIRE | 3 | JW1-JW3 | 0017-00033-0388 |
| " | 1 | JW4 | 0017-00033-0389 |
| HEATSINK MTG. HRDW. | 1 | JW4 | |
| SCREW, 5-40 X 6 | 1 | MHHS | 0017-00101-0821 |
| WSH 6-145-313-019 | 1 | MHHS | 0017-00104-0009 |
| NUT, 5-40 HET | 1 | MHHS | 0017-00103-0003 |
| HEATSINK COMPOUND | AS REQ. | MHHS | |
| SNAPBUSHIN, S, 1/8 | 4 | MHI-MH4 | 0017-00042-0014 |
| LAZARIAN SMD. P.C. | 1 | | A080-90911-E836 |

PROJ. ENG.: J. JARON

USED ON LAZARIAN

MIDWAY MFG. CO.

| | | | |
|---|------------|--------|----------------------|
| DO NOT SCALE DWG | HEAT TREAT | SCALE | NO REQ'D ONE (1) |
| DIM TOLERANCES UNLESS SPECIFIED | MAT'L | FINISH | PART NO. |
| CONVERTIBILITY FOR DEC. FRACTIONAL INCH | | | LAZARIAN SOUND BOARD |
| DECIMAL EQUIVALENT | | | COMPONENT DRAWING |
| | | | A084-90911-E636 |
| | | | M051-00636-E007 |

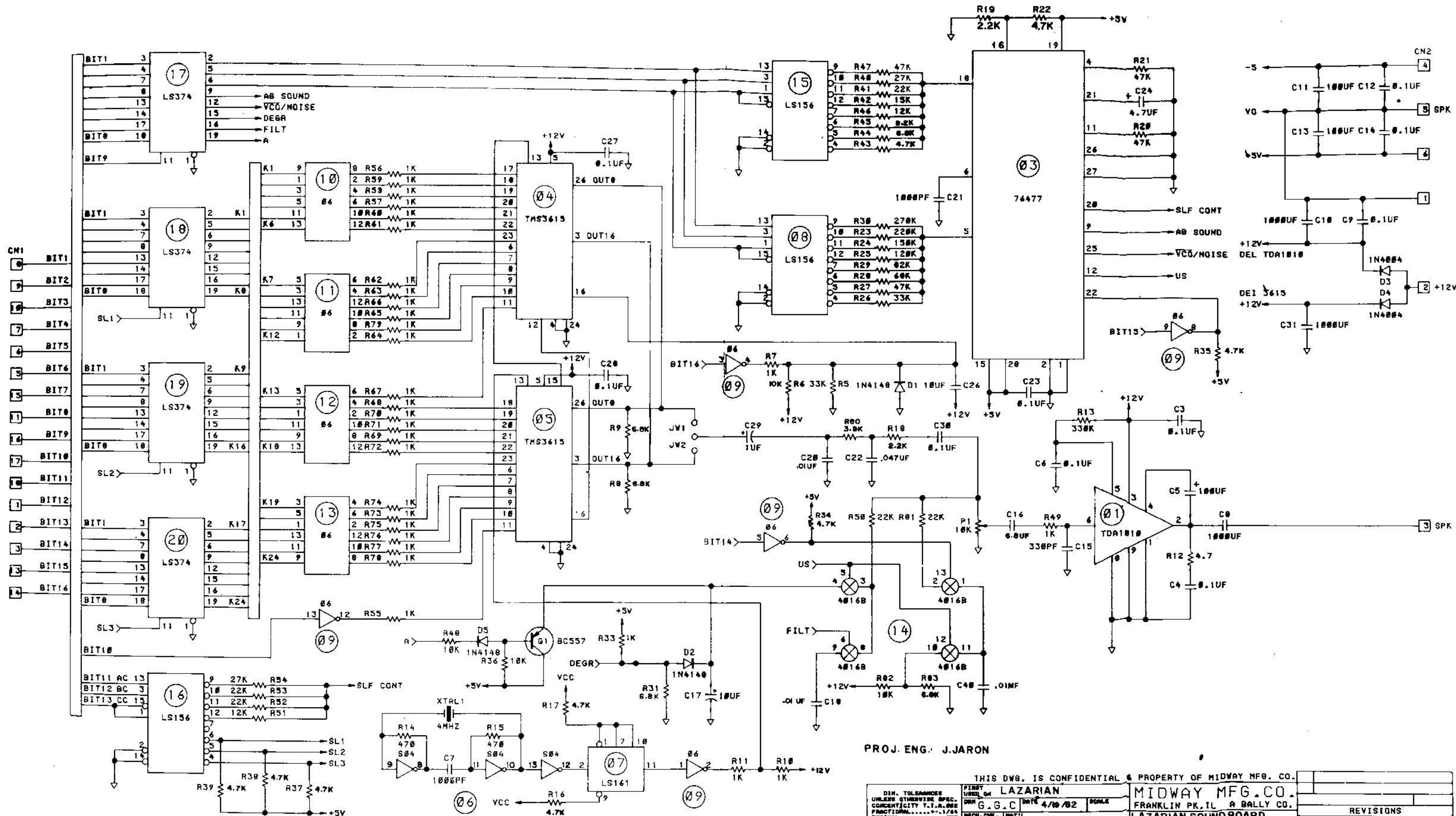

PROJ. ENG. J.JARON

THIS DWG. IS CONFIDENTIAL & PROPERTY OF MIDWAY MFG. CO.

| | | | | | |
|--|--|---|--|---|--|
| DTH. TOLERANCES UNLESS OTHERWISE SPEC. CONCENTRICITY 7.1, 8.000 FRACTIONAL .0005 DECIMAL .0005 HOLE DIA. .002-.005 ANGLE 1/2" DO NOT SCALE DWG | | LAZARIAN
DWN G.G.C DATE 4/10/82 SCALE | | MIDWAY MFG. CO.
FRANKLIN PK. IL A BALLY CO. | |
| MECH. CHK. NAT'L | | ELEC. CHK. FINISH | | REVISIONS
PART NO. M051-00636-E008 | |

LAZARIAN SOUNDBOARD SCHEMATIC A084-90911-F636

DESIGNATION LIST

| DESIGNATION | DESCRIPTION |
|-------------|-----------------------|
| C1 - C3 | 10MF 16V |
| C4 - C6 | .1 MF 50V |
| C7 - C9 | 10MF 16V |
| C10 - C12 | 22PF 50V 5% |
| C13 | 15MF 20V 20% |
| R1 - R3 | 6.8K 1/4W 5% |
| R4 - R6 | 3.3K " " |
| R7 - R9 | 1K " " |
| R10 - R11 | 300Ω " " |
| R12 | 270Ω " " |
| Q1 - Q3 | MPS A 20 |
| J1 | 3 POS. CONN.
5 " " |
| J2 | 2 POS. CONN.
4 " " |
| MH1 - MH4 | SNAPBUSHINGS |

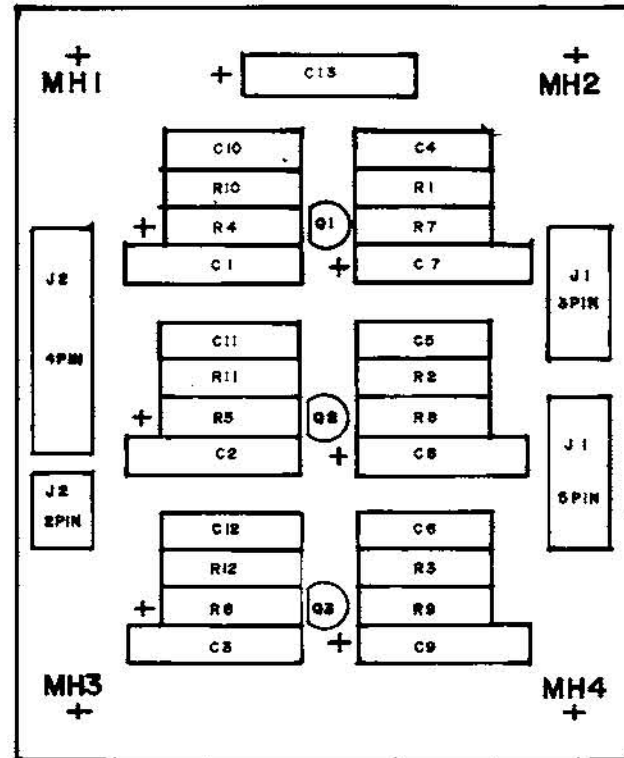

CROSS REFERENCE LIST

| DESCRIPTION | QUANTITY | DESIGNATION | PART NOS. |
|----------------------------|----------|-------------|----------------|
| 10MF 16V | 3 | C1 - C3 | 0636-00800-210 |
| .1 MF 50V | 3 | C4 - C6 | 0636-00800-200 |
| 10MF 16V | 3 | C7 - C9 | 0636-00800-210 |
| 22PF 50V 5% | 3 | C10 - C12 | 0636-00800-230 |
| 15MF 20V 20% | 1 | C13 | 0636-00800-220 |
| 6.8K 1/4W 5% | 3 | R1 - R3 | 0062-219B3-1XX |
| 3.3K " " | 3 | R4 - R6 | 0062-203B3-1XX |
| 1K " " | 3 | R7 - R9 | 0062-179B3-1XX |
| 300Ω " " | 2 | R10 - R11 | 0062-141B3-1XX |
| 270Ω " " | 1 | R12 | 0062-138B3-1XX |
| MPSA 20 | 3 | Q1 - Q3 | 0636-00802-04 |
| 3 POS. CONN. | 1 | J1 | 3000-16387-03 |
| 5 POS. CONN. | 1 | J1 | 3000-16387-05 |
| 2 POS. CONN. | 1 | J2 | 3000-16387-02 |
| 4 POS. CONN. | 1 | J2 | 3000-16387-04 |
| SNAPBUSHINGS | 4 | MH1 - MH4 | 0017-00042-00 |
| MONITOR INTERFACE P.C. BD. | | | A080-91422-B6 |

| REVISIONS |
|-----------|
| |

PROJ. ENG.: J. JARON

| | | | | | |
|---------------------------------|----------------|------------|---|----------------------|---|
| DO NOT SCALE DWG. | | HEAT TREAT | SCALE | USED ON LAZARIAN | MIDWAY MFG. CO.
FRANKLIN PK. ILL. |
| DIM TOLERANCES UNLESS SPECIFIED | | | FULL | NO. REQ'D 1(ONE) PER | |
| CONCENTRICITY T1R 003 | DRN <i>sgl</i> | MAT'L | LAZARIAN MONITOR INTERFACE ASSEMBLY DRAWING | | PART NO. |
| FRACTIONAL 1/64 | CKD | FINISH | A084-91422-B636 | | M051-00636-B016 |
| DECIMAL 005 | DATE 5/27/82 | | | | |
| HOLE DIA +002 000 | | | | | |

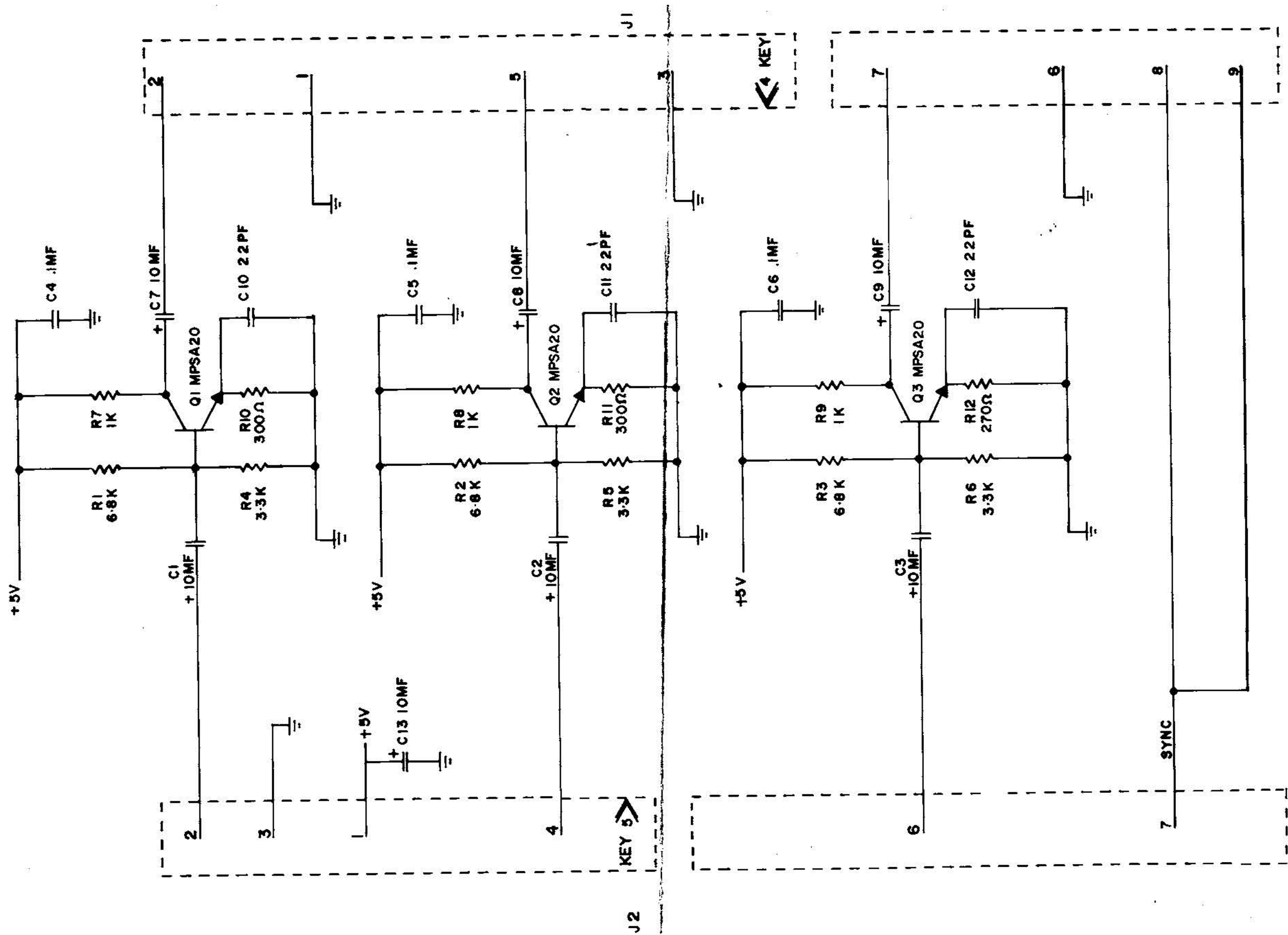

PROJ. ENG.: J. JARON

THIS DWG. IS CONFIDENTIAL & PROPERTY OF MIDWAY MFG CO

| | |
|--|---------------|
| DIM. TOLERANCES
UNLESS OTHERWISE SPEC | |
| CONCENTRICITY T.J.R. | .002 |
| FRACTIONAL | ± 1/64 |
| DECIMAL | ± .005 |
| HOLE DIA. | ± .002 - .000 |
| ANGLE | ± 1/2° |

| | | | |
|---------------|----------|--------|---------|
| FIRST USED ON | LAZARIAN | SCALE | FULL |
| DRN | SGJ | DATE | 3/16/82 |
| MECH. CHR. | | MAT'L | |
| ELEC. CHR. | | FINISH | |

MIDWAY MFG. CO.
FRANKLIN PK., ILL. 60131 A SALLY CO.

LAZARIAN MONITOR INTERFACE P.C.
A084-01422-8686
SCHEMATIC

| | |
|-----------|--------------------|
| REVISIONS | |
| PART NO | M05-1-00636-B-01-7 |

DESIGNATION LIST

| DESIGNATION | DESCRIPTION |
|-------------|-----------------------------|
| D1-D16 | IN4004 |
| J1 | 2 POS. KK156
14 POS. " " |
| J2 | 3 POS. KK156
11 POS. " " |
| J3 | 5 POS. KK156
8 POS. " " |
| J4 | 4 POS. KK156
7 POS. " " |
| MH1-MH4 | SNAP BUSHING |

CROSS REFERENCE LIST

| DESCRIPTION | QTY. | LOCATION | PART NOS. |
|--------------|------|----------|------------------|
| IN4004 | 16 | D1-D16 | 0064-030XX-XXXX |
| 2 POS. KK156 | 1 | J1 | 3000-16387-0200 |
| 3 POS. " " | 1 | J2 | 3000-16387-0300 |
| 4 POS. " " | 1 | J4 | 3000-16387-0400 |
| 5 POS. " " | 1 | J3 | 3000-16387-0500 |
| 7 POS. " " | 1 | J4 | 3000-16387-0700 |
| 8 POS. " " | 1 | J3 | 3000-16387-0800 |
| 11 POS. " " | 1 | J2 | 3000-16387-1100 |
| 14 POS. " " | 1 | J1 | 3000-16387-1400 |
| SNAP BUSHING | 4 | MH1-MH4 | .0017-00042-0014 |

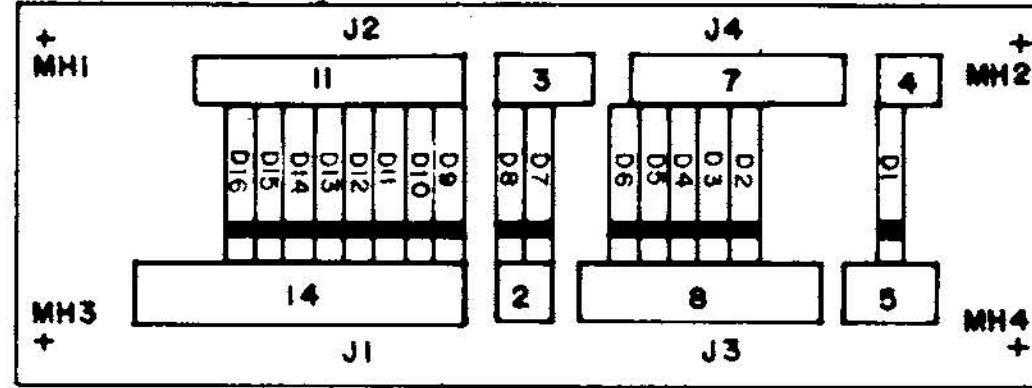

PROJ. ENG.: J. JARON

THIS DWG IS CONFIDENTIAL & PROPERTY OF MIDWAY MFG CO

| | | | | |
|--|---|--|---|--|
| DIM. TOLERANCES
UNLESS OTHERWISE SPEC
CONCENTRICITY T/R .002
FRACTIONAL ± .004
DECIMAL ± .005
HOLE DIA. ± .002 .000
ANGLE ± 12°
DO NOT SCALE DWG | DESIGNED BY: LAZARIAN
DRAWN: <i>SAL</i> DATE: 6/24/82 SCALE: FULL | | MIDWAY MFG. CO.
FRANKLIN PK., IL 60131 A BALLY CO | REVISIONS
PART NO
M051-00636-C015 |
| | CHECKED BY: <i>J.J.</i> | | | |

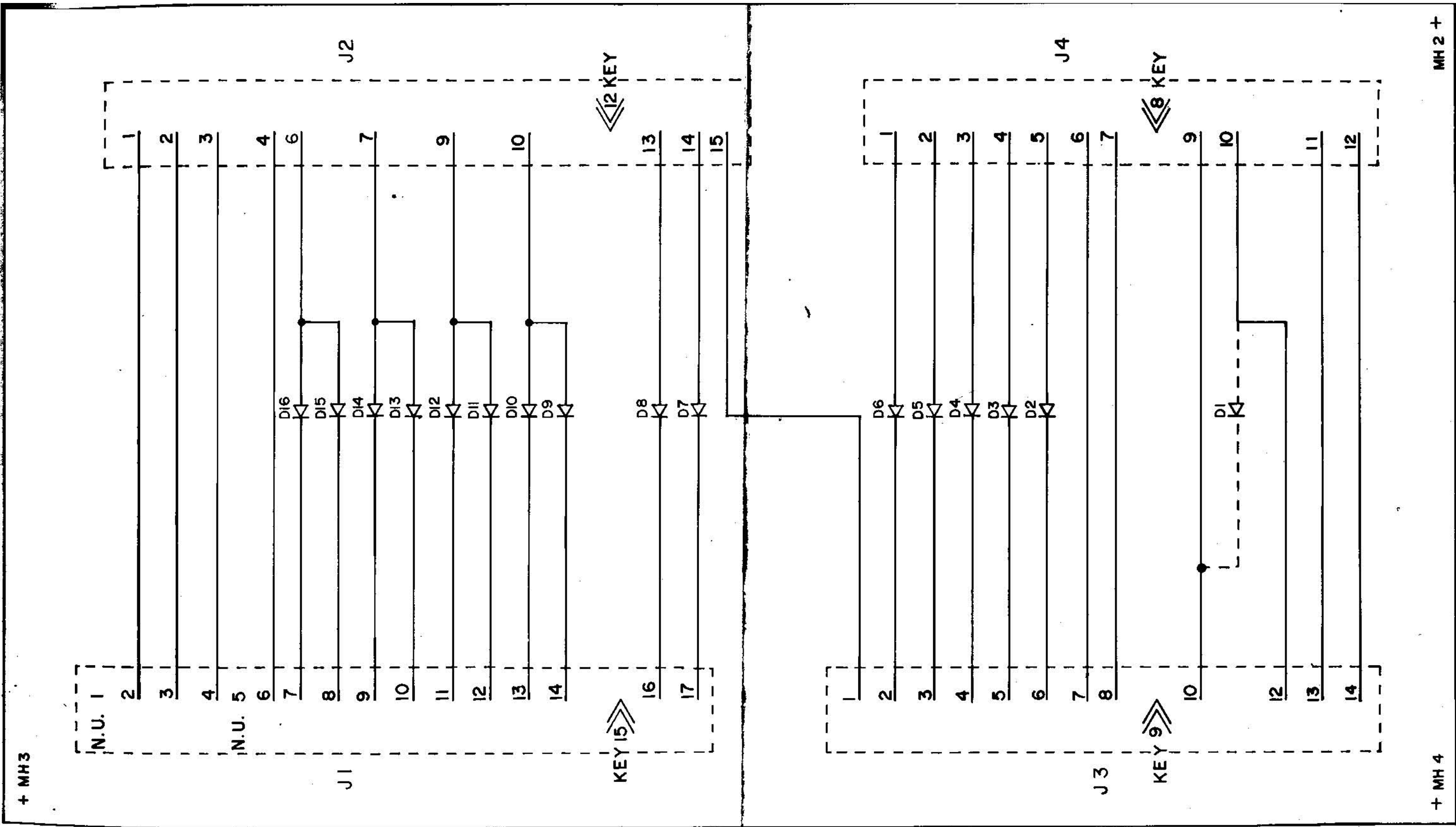

+ MH3

+ MH4

ALL DIODES ARE IN4004

PROG. ENG.: J. JARON

THIS DWG. IS CONFIDENTIAL & PROPERTY OF MIDWAY MFG. CO.

DIM. TOLERANCES
 UNLESS OTHERWISE SPEC.
 CONCENTRICITY T.I.R.002
 FRACTIONAL ... ± .1/64
 DECIMAL ... ± .005
 HOLE DIA. ... +.002-.000
 ANGLE ... ± 1/2°

FIRST USED ON: LAZARIAN
 DRN: *Sgt* DATE: 6/1/82 SCALE: FULL
 MECH. CHK: MAT'L:
 ELEC: FINISH:

MIDWAY MFG. CO.
 FRANKLIN PK., IL. 60131 A BALLY CO.
 LAZARIAN DIODE P.C. SCHEMATIC
 A084-91421-C636

| REVISIONS | |
|-----------|------------------|
| PART NO. | M-051-00636-C014 |