

THE MADALLEN E CHOPMAN UP-5 MANUAL

S-1 CAUTIONS	E MN-50001-0
A-1 SPECIFICATIONS	E MN-50028-0
B-1 MAINTENANCE	E MN-50029-0
B-2 CRT MONITOR	E MN-50029-0
B-3 DIP SWITCH SETTING	E MN-50030-0
B-4 SCREEN	E MN-50030-0
B-5 COIN SELECTOR	E MN-50005-0
B-6 SERVICE SWITCH	E MN-50005-0
C-1 HOW TO PLAY	E MN-50025-0
C-2 ON SCREEN LAYOUT	E MN-50026-0
D-1 CABINET ASSEMBLY	E MN-50031-0
D-2 ELECTRICAL PARTS	E MN-50032-0
D-3 CONTROL PANEL	E MN-50033-0
D-4 P.C.B. ASSEMBLY	E MN-50034-0
D-5 PARTS LIST	MN-50035-0
D-5 PARTS LIST	MN-50036-0

A-1 SPECIFICATIONS

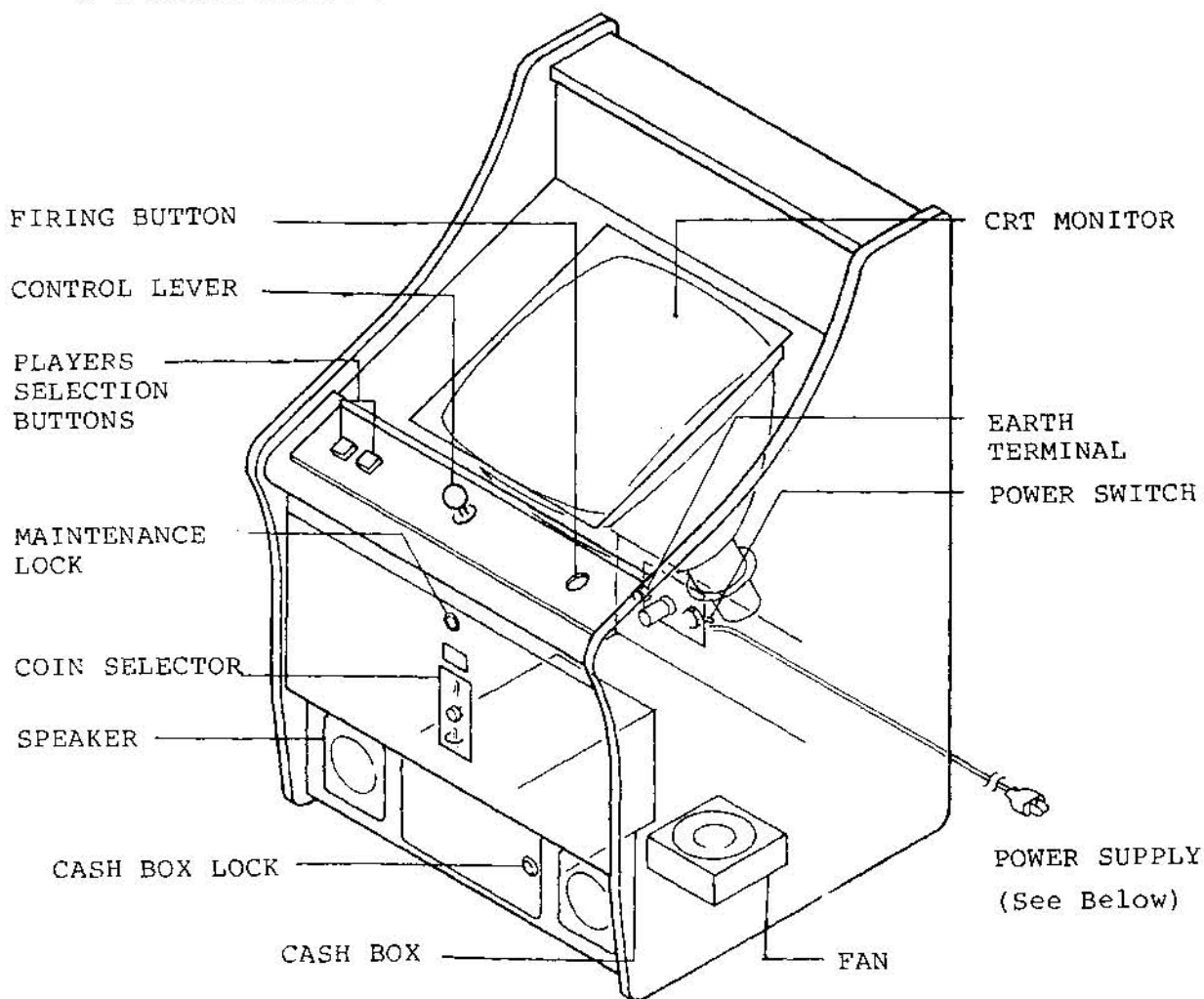

POWER SUPPLY:
 Please check that your machine is adjusted to your local voltage. If not consult your nearest repair center as the power supply unit and cord must be replaced.

POWER SUPPLY	AC115V, 220V, 240V \pm 10%
POWER CONSUMPTION	About 95W
GAME CHARGE	Adjustable (B-3)
DIMMENSIONS (m,m)	WxDxH=570x595x910
Weight (kg)	About 45kg
CASH BOX CAPACITY	About 1500 coins of 100yen
CRT	14 inch colour

These specifications may be changed without notice.

E MN-50028-0

B-1 MAINTENANCE

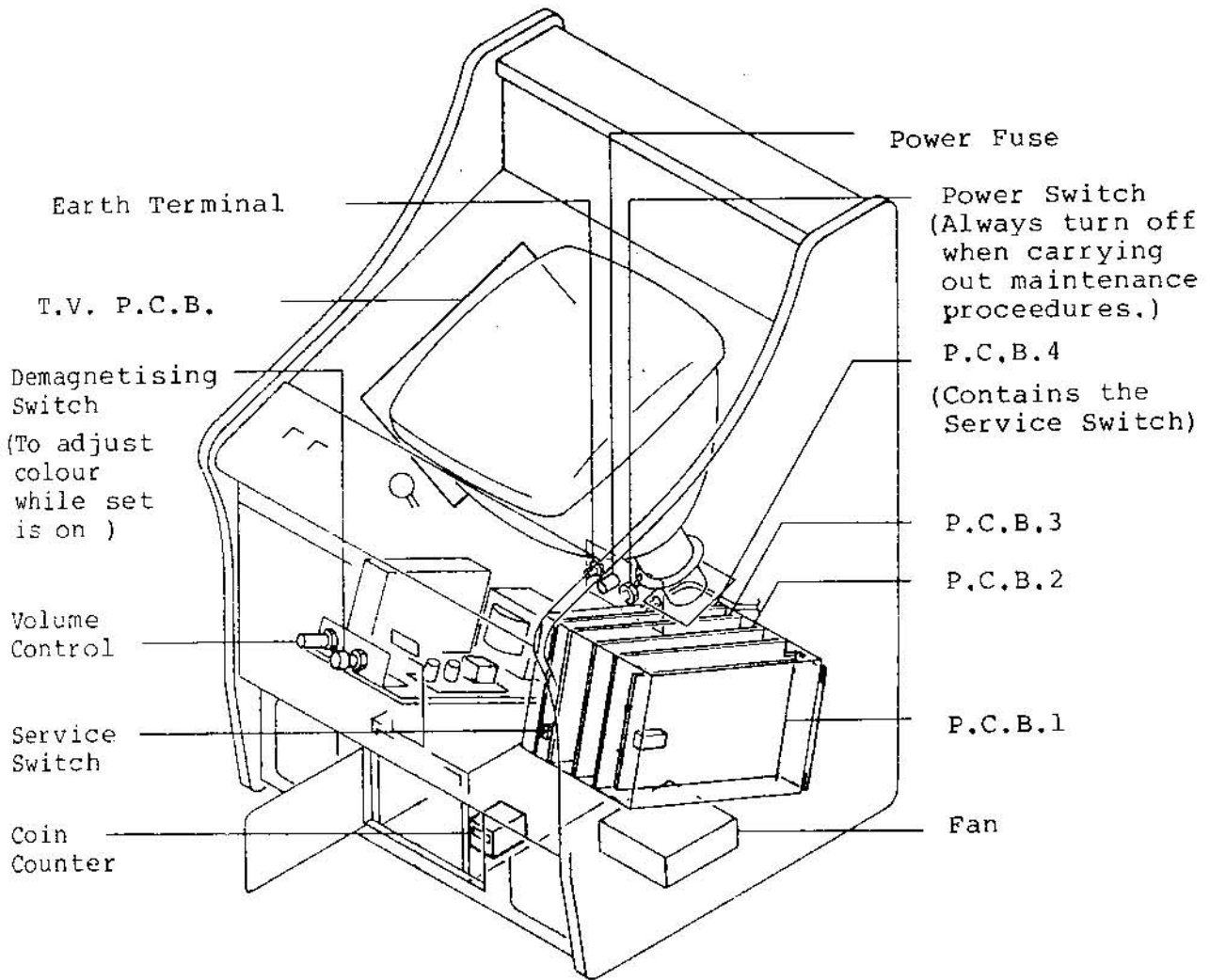

B-2 CRT MONITOR

To Adjust screen brightness to match room light. Usually this should not be necessary but if so, refer to the following chart.

1. The image is too small or too big.
2. The image flickers.
3. is not synchronised.
4. is too dark.

Turn the power off, and adjust according to the diagram below. If this does not improve the image then you will need to replace the T.V. assembly.

5. Colour Harmony
This will need to be adjusted by a qualified technician.

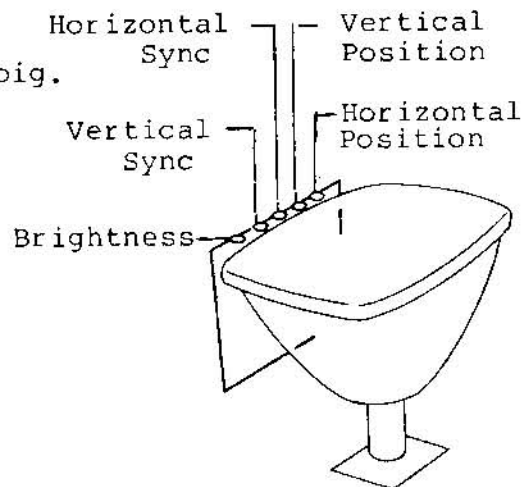

E MN-50029-0

B-3 DIP SWITCH SETTING

Turn power off and take out P.C.B.1 and adjust your game on the dip switch.

See setting diagram.

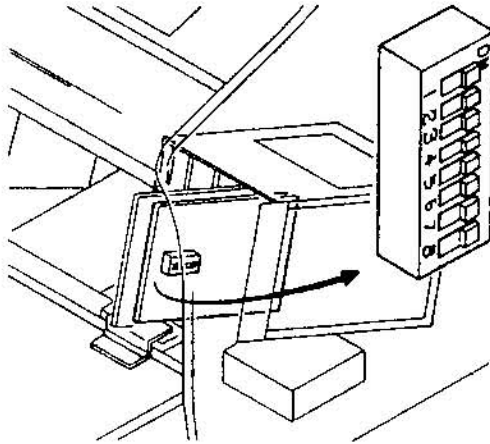

B-4 SCREEN

When you turn your set on.

1. If the screen does not light.
2. The screen lights but no image appears or the image remains motionless.
3. The colour is uneven.
4. The image moves to the side.

Check if the cord is plugged in firmly.
 Check the current at the consent. Turn power off and check the line fuse.
 Check if the set's service socket is unplugged.

Turn power off.
 Check if the game P.C.B. is set in firmly. If so replace it with a spare and switch on.
 If the image is normal, the original P.C.B. is faulty.

Depress the demagnetising switch for 3-4 seconds. (See B-1)
 This will be caused by a strong magnet placed too close to the set.

		B-5			
No	Set	Functions			
1	ON	OFF	ON	OFF	Number Of Car!
2	ON	ON	OFF	OFF	
		3	4	5	6
3	ON	OFF	ON	OFF	Game Charge
4	ON	ON	OFF	OFF	
		1 1	1 2	2 Coins 1 Play	
5	ON	OFF	ON	OFF	Bonus Points
6	ON	ON	OFF	OFF	
		3000	5000	7000	
7	ON				
	OFF				
8	ON	Prevent Turning			Game Screen
	OFF	To Turn			

B-6

B-5 COIN SELECTOR

1. A coin cannot be inserted. First check to see if the coin box is full. If not a coin may be jammed. Pull the lever to release. Next clean the coin slot entry thoroughly with alcohol. If the problem continues then the selector is faulty and the selector assembly will need replacing.
2. Coin does not register. Replace the service switch. If still faulty please see B-6,1. If the game can be played, turn power off and check the microswitch. If there is no fault in the micro switch, the fault is with the P.C. Board.
3. Coin is not counted. Check the coin counter, and see if the wire-lead inside is broken or not.

B-6 SERVICE SWITCH

Depress the service switch

1. If you press 1 player button and the game doesn't start. Turn the power switch off and check the service switch, and the single player switch. If there is no fault there then the fault is in the P.C. Board.
2. Sound. Use the volume control inside the cabinet to adjust sound by turning it right to increase. No sound. Turn power off and check the volume control. If there is no fault, the fault will be in the P.C.B..
3. Missiles are not fired. Turn power off and check the missile button. Otherwise the fault is in the P.C.B..
4. If the player's car does not move. Turn the power off and check the micro switch (See page 11). Otherwise the fault is in the P.C. Board.

E MN-50005-0

C-1 HOW TO PLAY

1. Insert coin.
2. Press the 1 player or 2 players button to start.
3. THE MAD ALIENS appear in a group at the top of the screen racing away from your car.
 - * Watch out, MAD ALIENS may leave the group and turn back to attack your car.
4. Use your lever on the left to move your car left or right across screen.
 - * Sometimes the road narrows making it difficult to dodge the MAD ALIENS.
 - * Dodge or destroy the obstacle cars -their purpose is to ram you -you must hit their tires to explode them.-
5. Lightly push the button on the right to fire.
 - * Your rockets can explode MAD ALIEN rockets in mid-flight.
6. Don't forget that if you destroy a MAD ALIEN as he circles back to attack you You will receive double points -and a chance to strike mystery bonus points.
 - * If you don't destroy the attacking MAD ALIENS they will return to play. You'll see them rejoin the group soon after they pass off the bottom screen.
7. When you enter a tunnel, beware as you cannot see the attacking MAD ALIENS until they come within range of your headlights.
8. If you collide with the enemy your car will explode.
 - * If all of your cars are destroyed, Your game is over. You'll need to insert another coin to play again.

E MN-50025-0

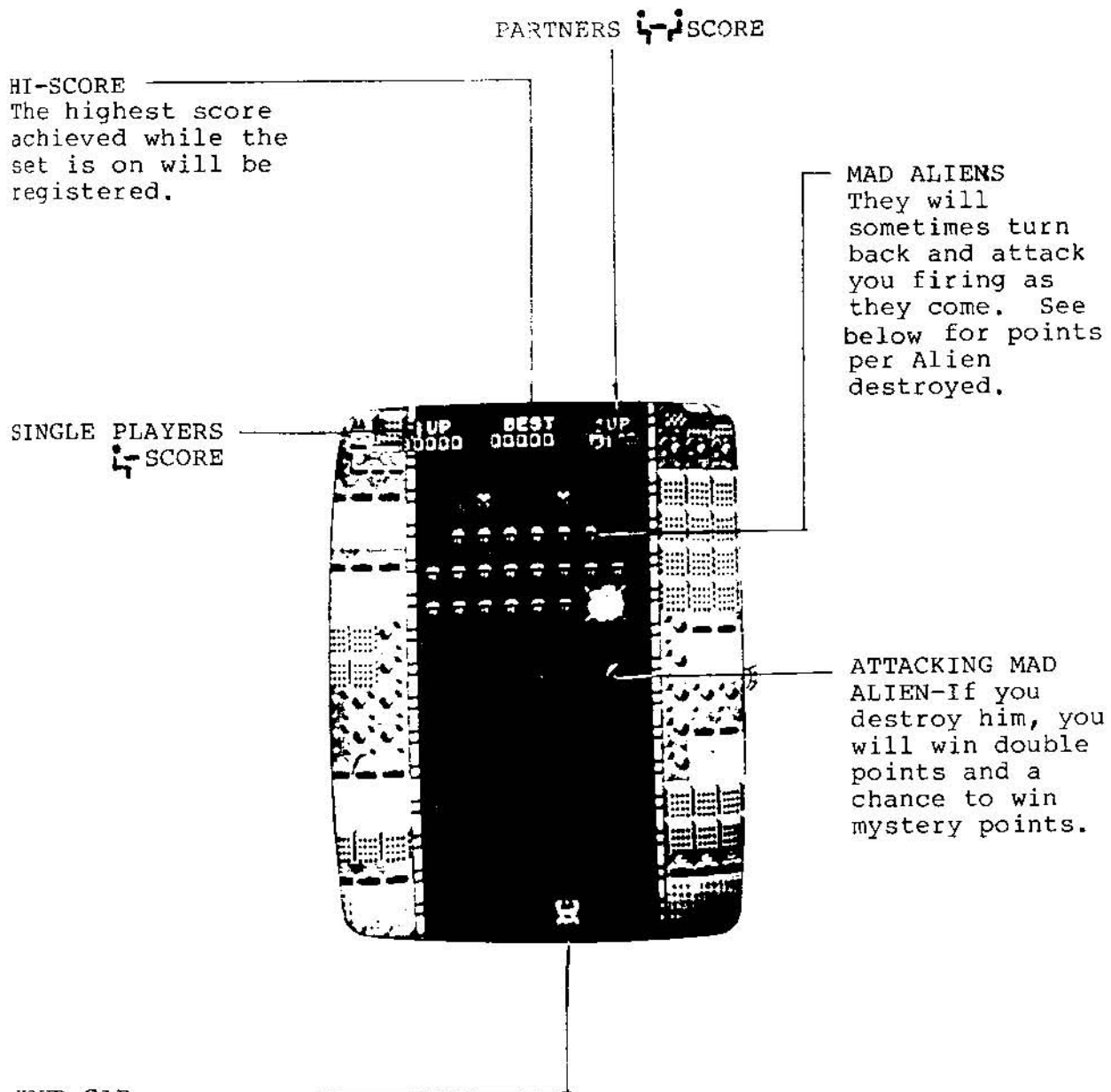



HI-SCORE
The highest score achieved while the set is on will be registered.

MAD ALIENS
They will sometimes turn back and attack you firing as they come. See below for points per Alien destroyed.

SINGLE PLAYERS SCORE

ATTACKING MAD ALIEN-If you destroy him, you will win double points and a chance to win mystery points.

YOUR CAR
Use the lever to move right or left across screen. Press the missile button to fire.

-  80 points
-  40 points
-  20 points

D-1 CABINET ASSEMBLY

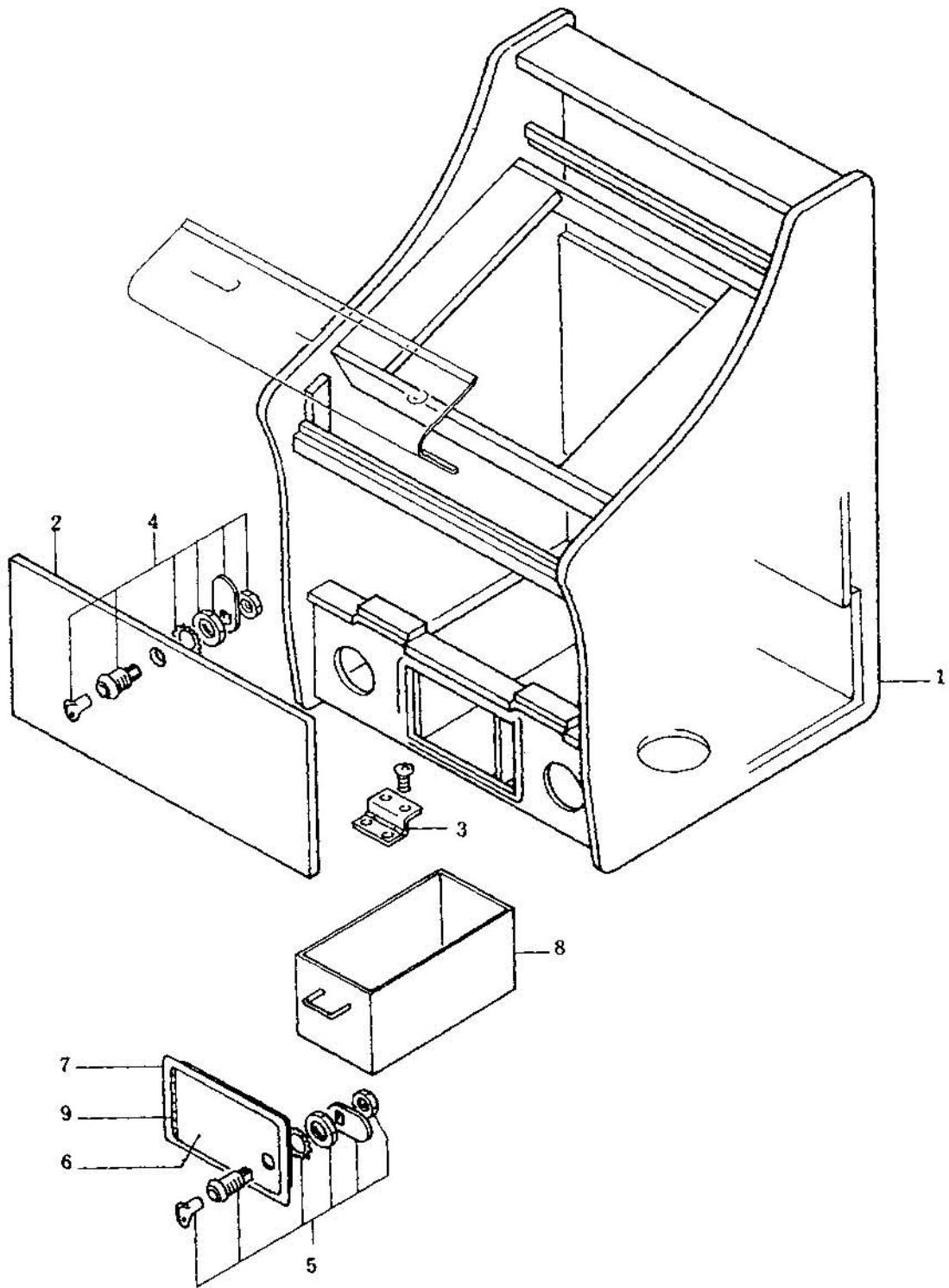

E MN-50031-0

D-2 ELECTRICAL PARTS

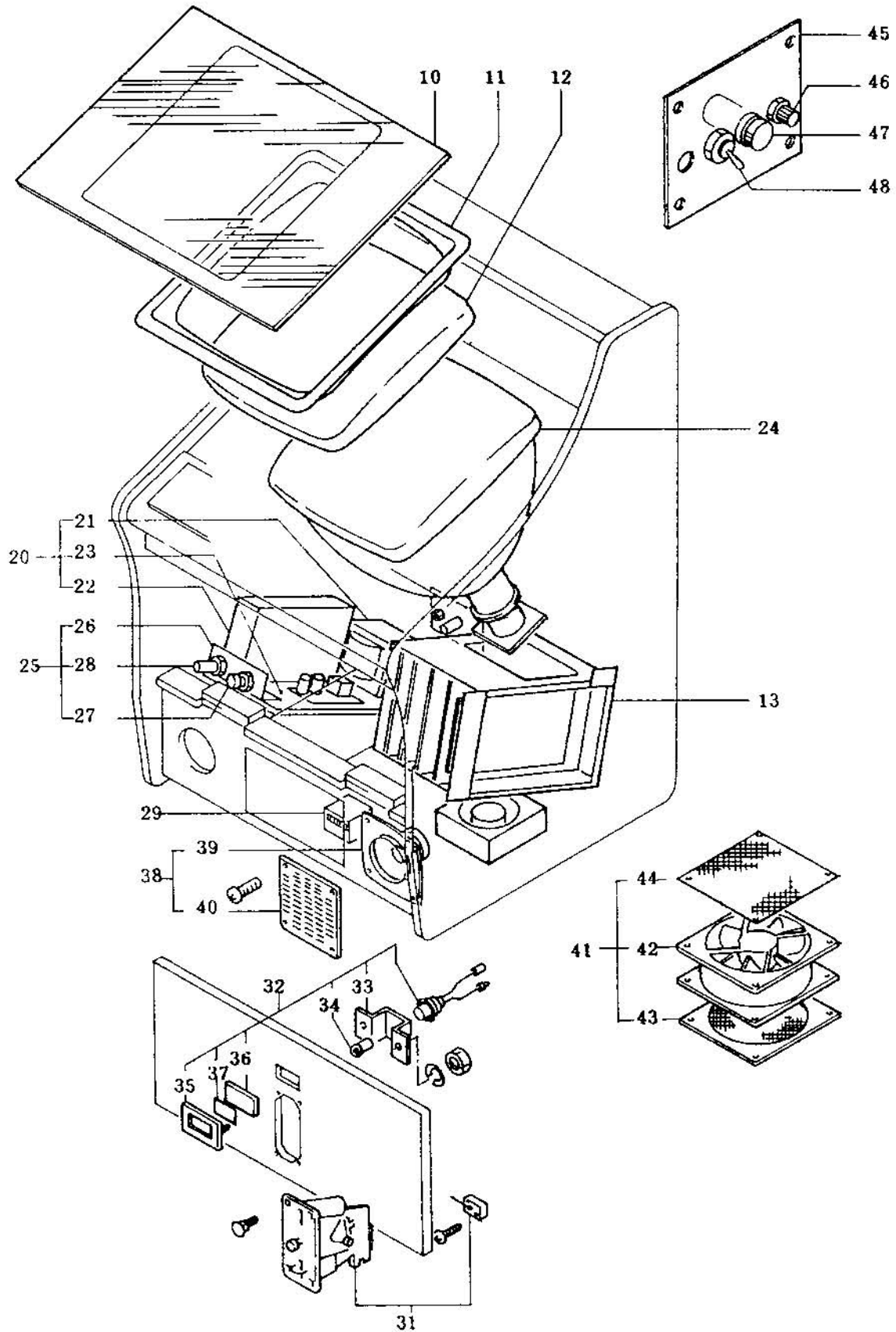

E MN-50032-0

D-3 CONTROL PANEL

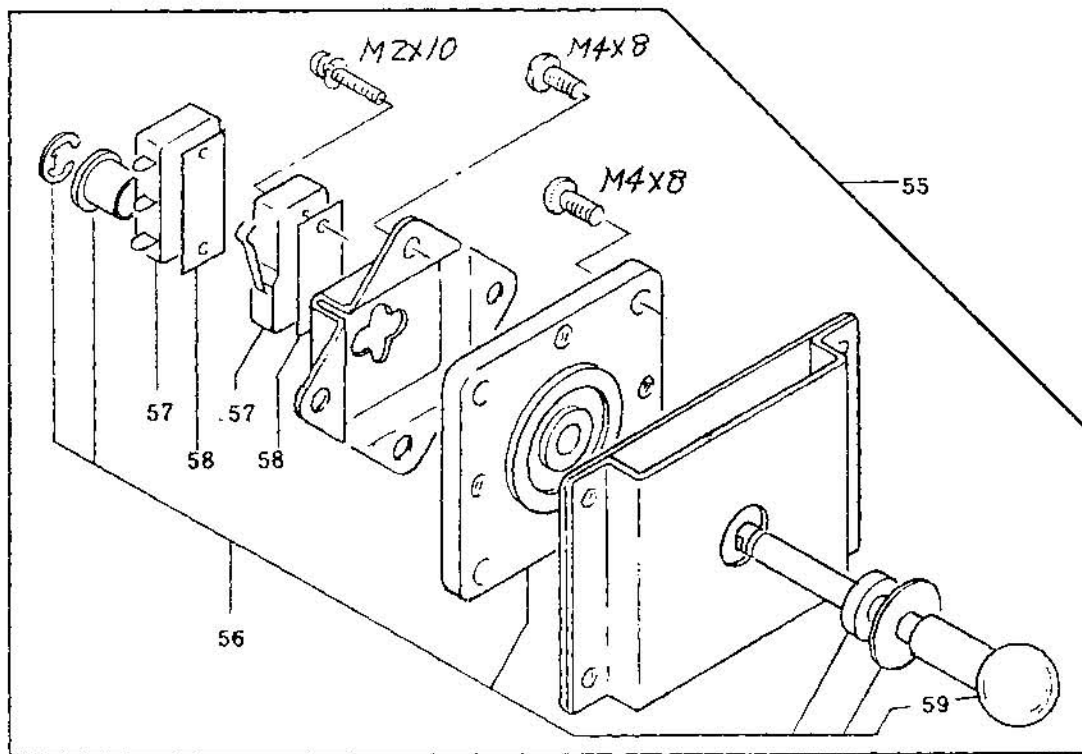
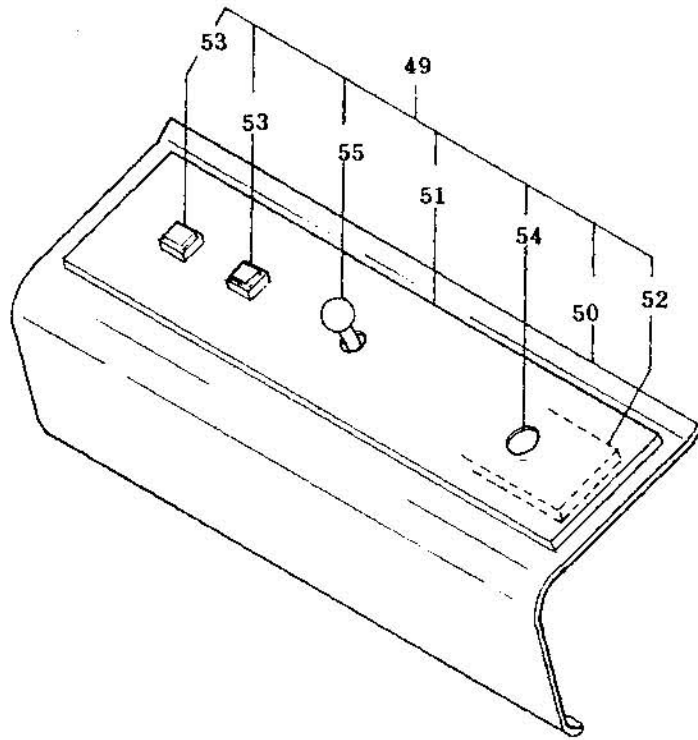

E. MN-50033-0

D-4 P.C.B. ASSEMBLY

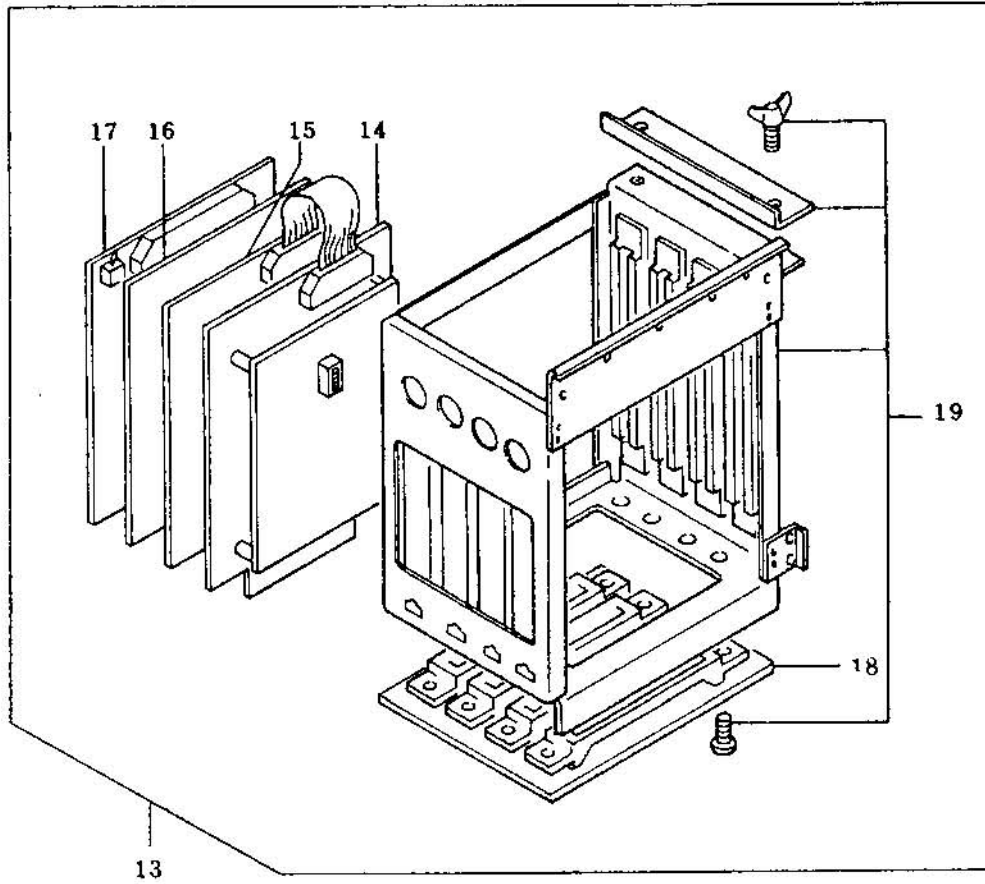

E MN-50034-0

Mini Up-5

Key No.	Description	Qty	Parts No.	Remarks	Price
1	Cabinet Ass'y (Wood)		ML-50194		
2	Maintenance Door	1	E-50010-0		
3	Hinge	1	G-50053-0		
4	Maintenance Key	1		D-6420	
5	Cashbox Key	1			
6	Cashbox Door	1	K-50171-0		
7	Door Frame	1	G-50055-0		
8	Cashbox	1	K-50173-0		
9	Hinge	1	K-50505-0		
10	Plastic Shield	1	P-50502-0		
11	Escutcheon	1	P-50042-0		
12	Plastic Light Filter	1	8033436-0		
13	PCB Wrack	1			
14	PCB 1	1			
15	PCB 2	1			
16	PCB 3	1			
17	PCB 4	1			
	Service Switch	1			
18	Mother Board	1			
19	PCB Wrack	1	ML-50197-1		
20	Power Unit Ass'y	1			
21	Transformer	1			
22	Regulator	1			
23	Chassis	1	G-50054-0		
	Fuse	1			
24	CRT Monitor Ass'y	1		14" Colour	
25	Switch Panel Ass'y	1			
26	Switch Panel	1	P-50237		
27	Demagnetizing Switch	1			
28	Volume Control	1			
29	Coin Counter	1			
	Counter Bracket	1	P-50444-0		
30					
31	Coin Selector Ass'y	1		720-D	
	Micro Switch	1			
32	Lamp Ass'y	1			
33	Lamp Bracket	1	P-50400-0		
34	Lamp	1			
35	Lamp Panel	1	P-50499-0		
36	Panel	1	P-50503-0		
37	Sticker (Coin Display)	1	P-50489-0		

MN-50035-0

Mini Up-5					
Key No.	Description	Qty	Parts No.	Remarks	Price
38	Speaker Ass'y	2			
39	Speaker	2			
40	Mask	2	P-50108-2		
41	Fan Ass'y	1			
42	Fan	1			
43	Fan Panel	1	P-50238-0		
44	Air Net	1			
45	Switch Panel	1	P-50390-0		
46	Earth Terminal	1			
47	Main Fuse	1			
48	Main Power Switch	1			
49	Control Panel Ass'y	1	G-50056-0		
50	Panel Chassis	1	P-50405-0		
51	Panel	1	K-50169-0		
52	Frame	1			
53	Switch Ass'y (Button)	1			
54	Switch Ass'y (Button)	1			
55	Lever Switch Ass'y	1	ML-50148-0		
56	Lever Ass'y	1			
57	Micro Switch	2			
58	Insulator	2	P-50093-0		
59	Knob	1			

MN-50036-0

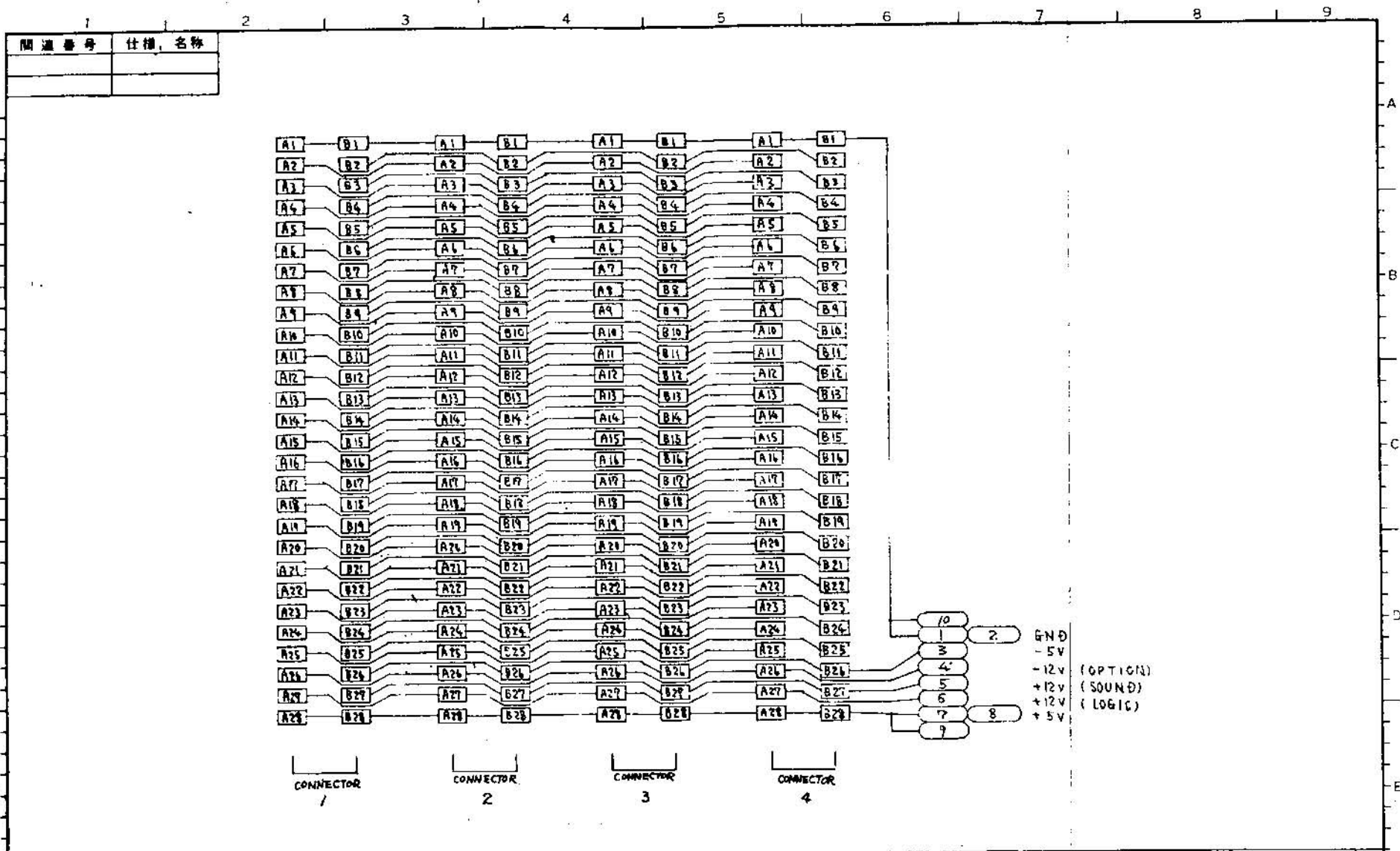

記号	年月日	改訂	個所	符号	部品、図面番号	名称	仕様、材質	3/4
材質					公差	名称	(DE-0037)	
					單位 mm	MOTHER BOARD		
承認					尺規	図番	K-10092	1/1

記 事

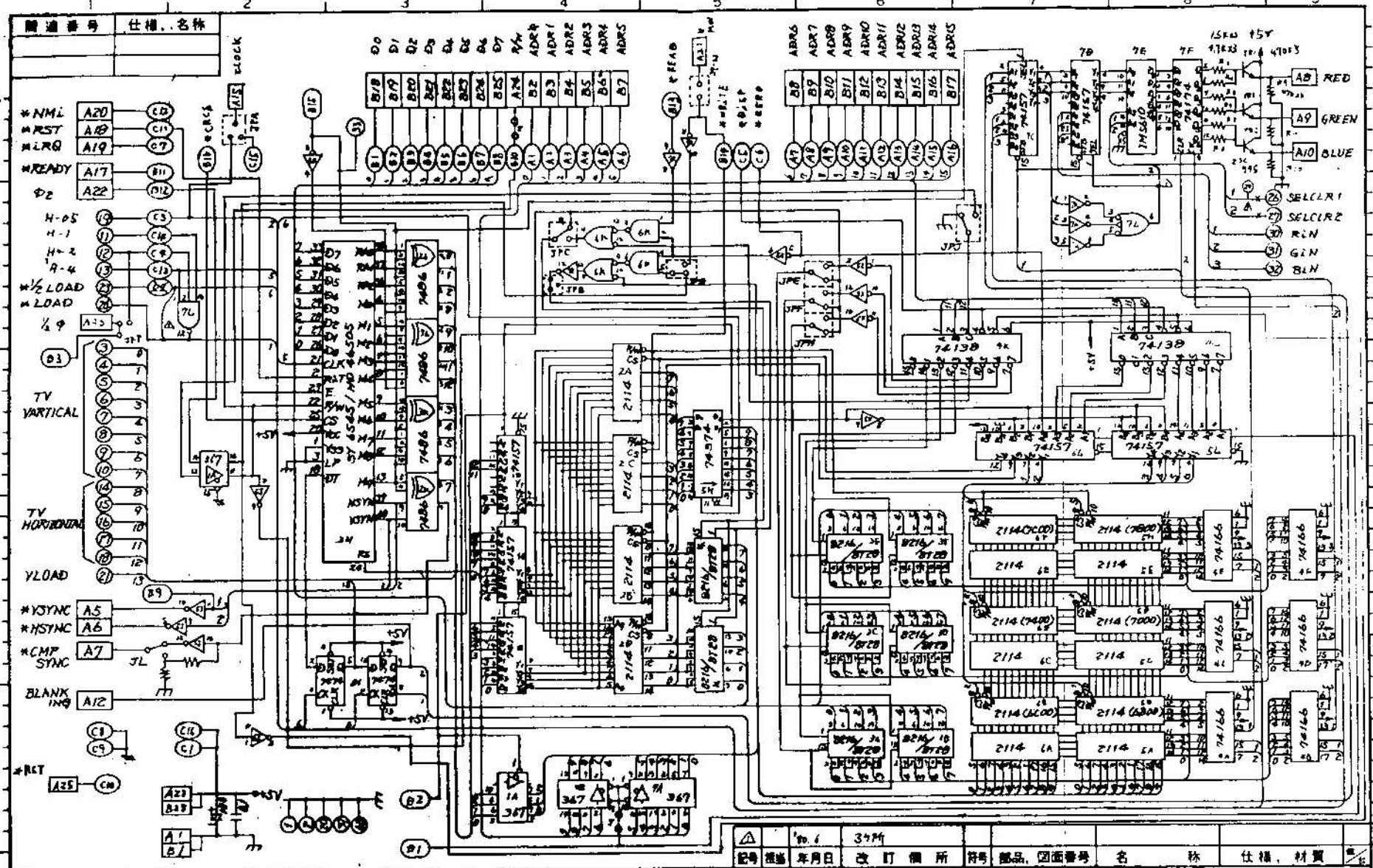

記事

記号	年月日	改訂	備所	符号	部品	図面番号	名称	仕様	材質
							MAD ALIEN		
							DSP-1		
							DE-0044-1		
							K-10141		

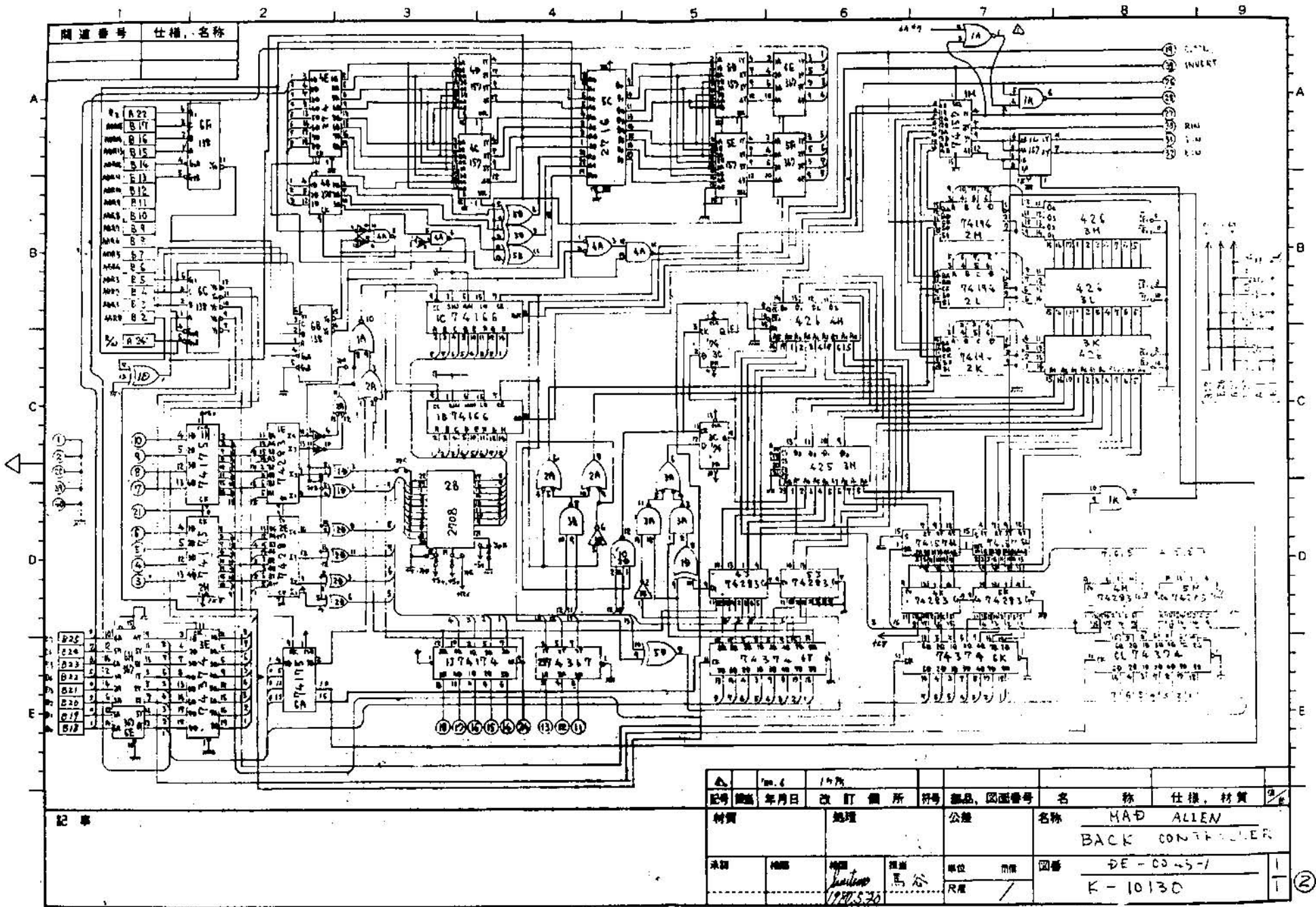

△	№. 4	1/4%							
記号	年月日	改訂	個所	符号	部品、図番番号	名称	仕様、材質		
材質						名称	MAD ALIEN BACK CONTROLLER		
承認	日期	署名	位置	単位	階層	図番	DE-0345-1 K-10130		②

