



Megatouch Ion Hard Drive Upgrade

Visit the AMI Entertainment Network Web site
<http://www.amientertainment.com>



PM0590-24

Table of Contents

Motherboard and Hard Drive Diagrams	p. 1-2
Hard Drive Removal and Installation	p. 3-13
eVo, eVo Walleto and Elite Edge Games	p. 3-4
Fusion Games	p. 5-8
Rx Games	p. 9
Standard Aurora Games	p. 10-11
Aurora Widescreen Games	p. 12-13
Software License Agreements	p. 14-19
English	p. 14-15
French	p. 16-17
German	p. 18-19

© 2010 AMI Entertainment Network, Inc.

Ion, MegaNet, Megatouch, TournaMAXX and TournaCHAMP are registered trademarks of AMI.

Reproduction of this manual, in any form or by any means, is strictly forbidden without the written permission of AMI.

Megatouch Ion Edition Hard Drive Upgrade

NOTE: This hard drive upgrade kit comes with software discs as well, in the event that the software needs to be reloaded at any time.

IMPORTANT!

Since we have switched to SATA hard drives, this hard drive installation will differ depending on your cabinet type. For **eVo**, **Elite Edge**, **eVo Wallethe/Entertainer**, and **Fusion** games with **PATA** hard drives, you must know what kind of motherboard is in your game in order to correctly install this kit. These games require a SATA to PATA adapter (part number SB0679-01 for Fusion games, and SB0676-01 for all other games).

This information is not needed for Aurora, Rx or games that already have SATA hard drives. Use the motherboard diagrams below to identify your motherboard.

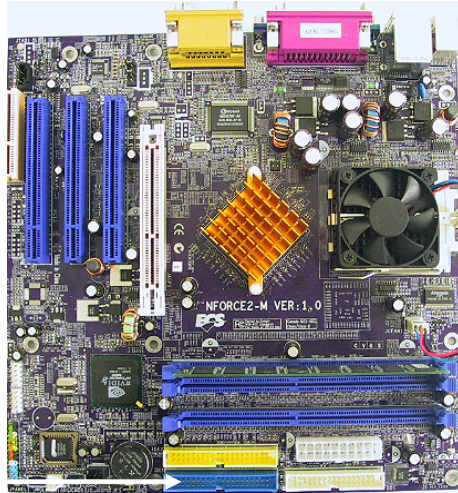

HARD DRIVE
CONNECTION
(PRIMARY IDE)

FIGURE 1 - ION ECS MOTHERBOARD

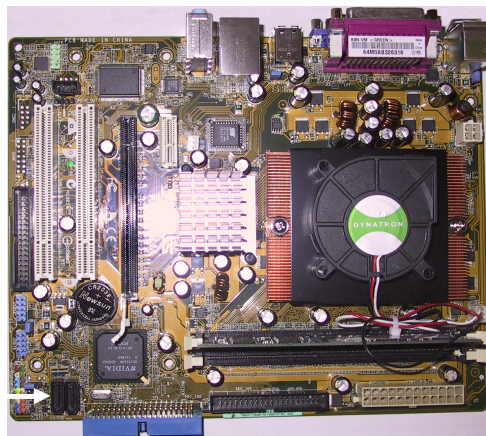

HARD DRIVE
CONNECTION
("SATA 1")

FIGURE 2 - ION ASUS MOTHERBOARD

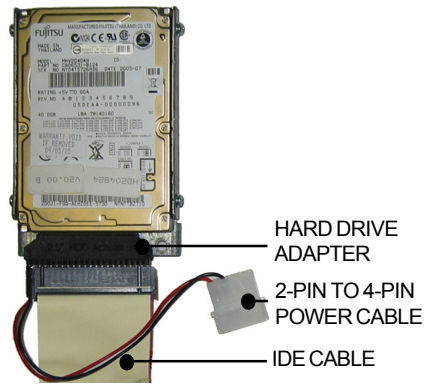

FIGURE 3 - OLD **PATA** HARD DRIVE ASSEMBLY

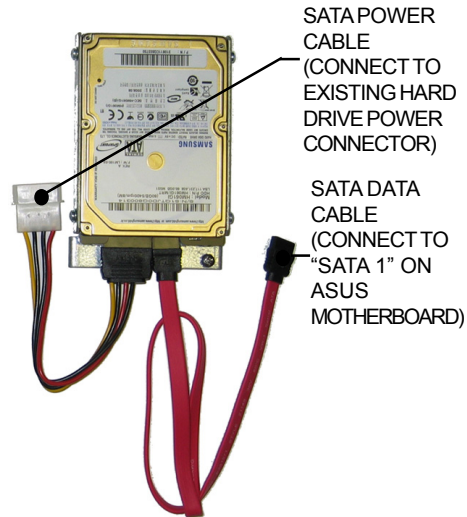

FIGURE 4 - NEW **SATA** HARD DRIVE ASSEMBLY FOR GAMES WITH **ASUS** MOTHERBOARDS, AND FOR WIDESCREEN AURORAS AND RX GAMES

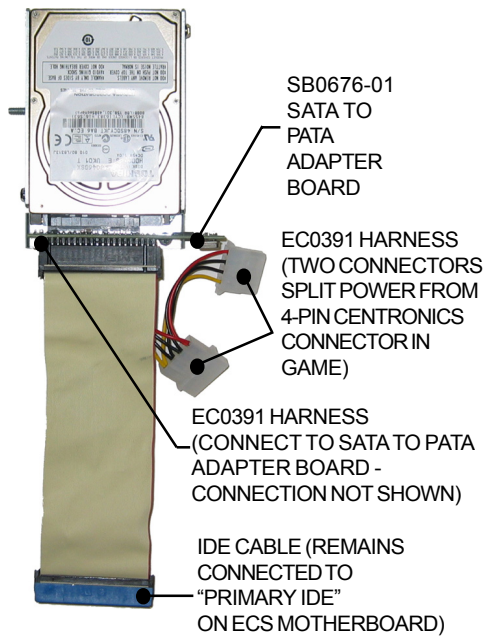

FIGURE 5 - NEW **SATA** HARD DRIVE ASSEMBLY FOR **EVO, EDGE, & WALLETT/ENTERTAINER** GAMES WITH **ECS** MOTHERBOARDS



FIGURE 6 - NEW **SATA** HARD DRIVE ASSEMBLY FOR **FUSION** GAMES WITH **ECS** MOTHERBOARDS (SEE FIGURE 9 FOR CONNECTIONS)

eVo, eVo Wallete / Entertainer and Elite Edge Games

1. If you are connected to TournaMAXX or TournaCHAMP, you must perform an **Update From Server** before removing the hard drive so that no information is deleted.
2. Turn off and unplug the game.
3. Unlock and open the CPU section.
4. Using Figures 3-4, determine which hard drive assembly you currently have in your game. If you have a PATA hard drive, continue with step 5a; if you have a SATA hard drive, continue with step 6a.

PATA hard drives ONLY:

- 5a. Disconnect the hard drive adapter (with its attached cabling) from the hard drive (see Figures 3 and 7).
- 5b. Use Figures 1-2 to determine what kind of motherboard is in your game. For ECS motherboards, continue with step 5c, for ASUS, continue with 5d.
- 5c. **If you have an ECS motherboard,** disconnect and remove the hard drive adapter and the 2-pin to 4-pin power cable from the IDE cable, leaving the other end of the IDE cable connected to the motherboard (see Figure 3).
- 5d. **If you have an ASUS motherboard,** disconnect the 2-pin to 4-pin power cable and the IDE cable and remove them both from the game (they will not be reused). Connect one end of the provided SATA power cable to this now free 4-pin power connector in the game (see Figures 3 and 4).
- 5e. Remove the screw securing the hard drive mounting bracket to its mounting

plate (see Figure 7). Remove the hard drive from its mounting plate by sliding the assembly down and off the bracket.

- 5f. Slide the new hard drive assembly onto the game's mounting plate. Be sure that the hard drive is flush to the mounting plate when doing so. Align the hole in the mounting bracket with the hole on the mounting plate, then secure the assembly with the supplied screw.
- 5g. **ECS motherboards ONLY:** Referring to Figure 5, connect the mating connector on the supplied EC0391 harness to the provided SATA to PATA adapter board. Connect the free end of the IDE cable inside the game to the SATA to PATA adapter board. Then, connect the provided SATA to PATA adapter board to the hard drive.

Locate the 4-pin connection from the centronics upgrade connector inside the game (see Figure 7). Disconnect this 4-pin connection and connect each of the mating connectors on the EC0391 harness to these two 4-pin connectors (see Figure 5). Skip to step 7.

- 5h. **ASUS motherboards ONLY:** Connect the free end of the SATA power cable (installed in step 5d) to the hard drive as shown in Figure 4. Connect the provided SATA data cable to the hard drive as shown in Figure 4 and connect the other end of this cable to the "SATA 1" header on the motherboard (see Figure 2). Skip to step 7.

SATA hard drives ONLY:

- 6a. Disconnect the SATA power cable and SATA data cable from the hard drive (see Figure 4).
- 6b. Remove the screw securing the hard drive mounting bracket to its mounting

- plate (see Figure 7) and remove the hard drive by sliding the assembly down and off the bracket.
- 6c. Reconnect the SATA power and data cables to the new hard drive as shown in Figure 4.
- 6d. Slide the new hard drive assembly onto the game's mounting plate. Be sure that the hard drive is flush to the mounting plate when doing so. Align the hole in the mounting bracket with the hole on the mounting plate, then secure the assembly with the supplied screw.
-
7. If you are **not** installing a security key, skip to step 10.
8. Locate the security key (the button-shaped disc with the handle) on the OSD board (see Figure 7). Remove the existing security key from the OSD board by sliding it out of place. Slide the new security key into place.
9. Close and lock the CPU section.
10. Remove the three Allen screws securing the marquee cover using a 1/16" Allen wrench. Replace the existing marquee with the supplied marquee and re-secure the cover.
11. Plug in and turn on the game. The game will reboot twice to configure the hardware. When prompted, perform a touch-screen calibration.
12. If you are connected to TournaMAXX or TournaCHAMP, you must re-enter the dial-in settings after completing the software upgrade. After entering the settings, make the initial call into the server, and then perform two **Updates From Server**. Refer to the MegaNet manual for information on how to perform these functions.

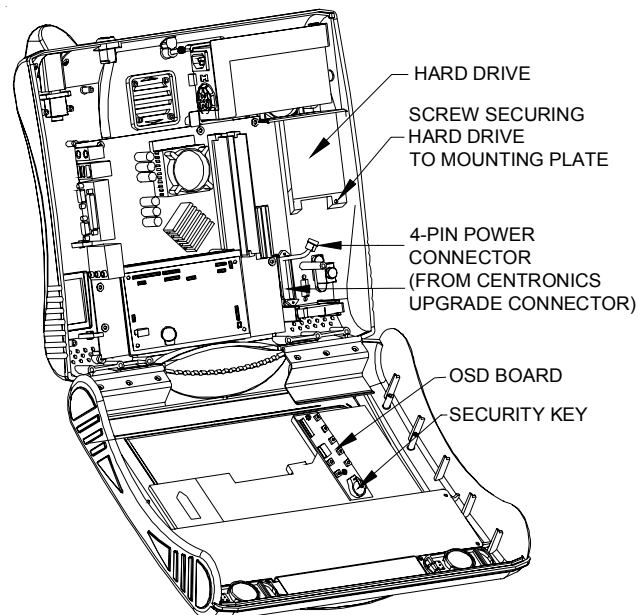

FIGURE 7 - EVO, EVO WALLETTTE / ENTERTAINER, AND ELITE EDGE WITH CPU SECTION OPEN

Fusion Games

1. If you are connected to TournaMAXX or TournaCHAMP, you must perform an **Update From Server** before removing the hard drive so that no information is deleted.
2. Turn off and unplug the game.
3. Unlock and open the front bezel.
4. Using Figures 3-4, determine which hard drive assembly you currently have in your game. If you have a PATA hard drive, continue with step 5a; if you have a SATA hard drive, continue with step 6a.
- 5a. To remove the electronics box cover, disconnect the 2 or 3 fan connections on the face of the electronics box. Also, disconnect the 2 OSD board connections and route the wires back into the electronics box through the access hole to the right of the hard drive (see Figure 8). Remove the 2 screws securing the electronics box cover and carefully remove the cover (see Figure 8).
- 5b. Use Figures 1-2 to determine what kind of motherboard is in your game. For ECS motherboards, continue with step 5d; for ASUS, continue with step 5m.

PATA hard drives ONLY:

- 5a. Remove the screw on the hard drive support bracket (this bracket and screw will not be reused). Then, disconnect the hard drive adapter (with its attached cabling) from the hard drive (see Figure 3). Remove the screw securing the hard drive assembly to the electronics box (see Figure 8) and remove the hard drive assembly. Route the hard drive cabling into the electronics box through the access hole to the left of the now-absent hard drive.

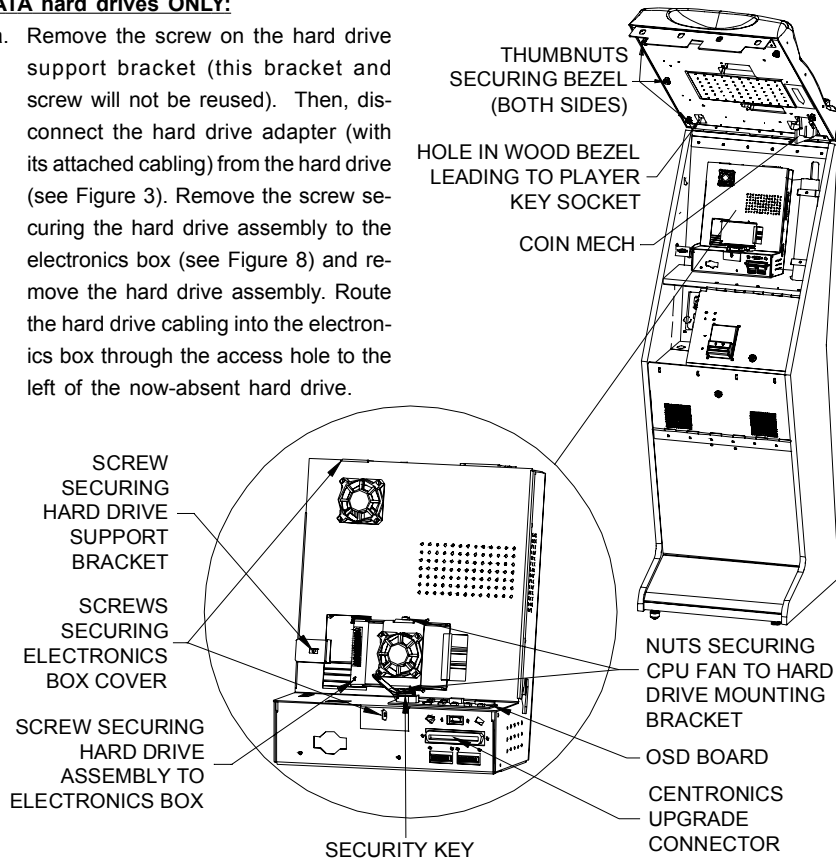

FIGURE 8 - FUSION GAME WITH DETAIL VIEW OF ELECTRONICS BOX

- 5d. **If you have an ECS motherboard,** Disconnect the 4-pin power cable (currently attached to the IDE cable) from its connection inside the electronics box and connect this 4-pin connector to the provided EC0358 SATA power cable. See Figure 9.
- 5e. Connect the provided EC0391-01 harness and the SATA data cable to the provided adapter board as shown in Figure 9.
- 5f. Disconnect and remove the IDE cable from the motherboard (this cable, along with the 2-pin to 4-pin power cable will not be reused). Connect the mating connector on the provided adapter board to the "IDE1" header on the motherboard (where the IDE cable was previously connected). See Figure 9.
- 5g. Locate the 4-pin connection coming from the centronics upgrade connector inside the electronics box (see Figure 8). Disconnect this 4-pin connection and connect each of the mating connectors on the EC0391 harness to these two 4-pin connectors (see Figure 9). Hold the electronics box cover up to the electronics box and route the free end of the SATA data cable and the EC0358 harness through the access hole in the electronics box cover to the left of the absent hard drive (see Figure 8). Route the two OSD board connectors through the access hole to the right of the absent hard drive.
- 5h. Separate the CPU fan mounting plate from the old hard drive by removing the one or two nuts. Reattach the CPU fan assembly to the new hard drive with the same nut(s).
- 5i. Connect the free ends of the EC0358 (SATA power cable) and the SATA data cable to the new hard drive as shown in Figure 9.
- 5j. Slide the new hard drive assembly into place on the electronics box cover. Align the hole in the mounting bracket with the hole on the mounting plate, and then secure it with the screw.
- 5k. Replace the cover on the electronics box and secure it with the two screws. Reconnect the two or three fan connections you removed. Reconnect the two OSD board connections (see Figure 8).
- 5l. Continue with step 7a to install a marquee, or step 8 to install the security key.

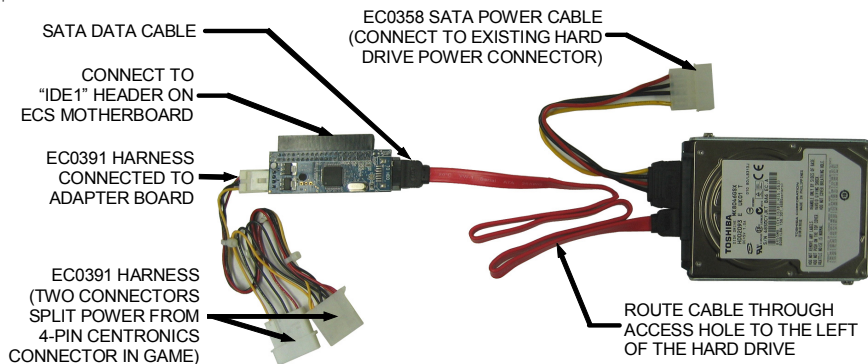

FIGURE 9 - SATA TO PATA ADAPTER BOARD AND CABLING (ECS MOTHERBOARDS ONLY)

- 5m. **If you have an ASUS motherboard,** disconnect the 2-pin to 4-pin power cable and the IDE cable and remove them from the game (they will not be reused). Connect one end of the provided SATA power cable to this now free 4-pin power connector in the game (see Figures 3 and 4).
- 5n. Separate the CPU fan mounting plate from the hard drive mounting bracket by removing the 2 nuts (see Figure 8). Reattach the CPU fan mounting plate to the provided hard drive assembly with these 2 nuts.
- 5o. Slide the new hard drive assembly into place on the electronics box cover. Align the hole in the mounting bracket with the hole on the mounting plate, and then secure it with the supplied screw.
- 5p. Connect one end of the provided SATA data cable to the "SATA 1" header on the motherboard (see Figure 2). Hold the electronics box cover up to the electronics box and route the free ends of both the SATA power cable (connected in step 5e) and data cable through the access hole to the left of the hard drive. Also route the 2 OSD board connections through the access hole to the right of the hard drive. Then, connect the hard drive cables to the hard drive as shown in Figure 4.
- 5q. Replace the cover on the electronics box and secure it with the 2 screws. Reconnect the 2 or 3 fan connections that you removed. Reconnect the 2 OSD board connections. Continue with step 7.
- SATA hard drives ONLY:**
- 6a. Disconnect the SATA power cable and SATA data cable from the hard drive (see Figure 4).
- 6b. Remove the screw securing the hard drive mounting bracket to its mounting plate (see Figure 8). Slide the hard drive assembly off the electronics box cover.
- 6c. Separate the CPU fan mounting plate from the hard drive mounting bracket by removing the 2 nuts (see Figure 8).
- 6d. Reattach the CPU fan mounting plate to the provided hard drive assembly with the 2 existing nuts (see Figure 8).
- 6e. Reconnect the SATA power and data cables to the new hard drive as shown in Figure 4.
- 6f. Slide the new hard drive assembly into place on the electronics box cover. Align the hole in the mounting bracket with the hole on the mounting plate, then secure in place with the supplied screw.

- 7a. To install the marquee, first remove the 6 thumbnuts, located on the underside of the wooden bezel, which fasten the plastic bezel to the game (see Figure 8).
- 7b. Disconnect the 2-pin wire coming from the player key socket at the top-left of the bezel (see Figure 8). Remove the 2 fast-on connectors attached to the coin mech on the opposite side of the bezel.
- 7c. Lift the plastic bezel only enough to gain access to the wires underneath, then disconnect the joystick harness and remove the wires from the plastic mounting clip on the wood bezel. Remove the plastic bezel.
- 7d. Remove the 6 nuts and washers securing the plastic sign holder on the inside of the plastic bezel, remove the sign holder, and replace the sign. Replace the 6 nuts and washers to re-secure the plastic sign holder.
- 7e. Replace the plastic bezel on top of the wood bezel, making sure that the wire coming from the player key socket drops through the hole in the wood bezel (see Figure 8).
- 7f. Lift the plastic bezel just enough to re-connect the joystick harness wire and slide it back into place under the plastic mounting clip on the wood bezel.
- 7g. Reattach the 2 fast-on connectors to the coin mech, and reattach the 2-pin wire coming from the player key socket (see Figure 8). Resecure the 6 thumbnuts securing the bezel. If you are **not** installing a security key, skip to step 9.
8. Locate the security key (the button-shaped disc with the handle) on the OSD board (see Figure 8). Remove the existing security key from the OSD board by sliding it out of place, and replace it with the supplied security key.
9. Close and lock the bezel.
10. Plug in and turn on the game. The game will reboot twice to configure the hardware. When prompted, perform a touch-screen calibration.
11. If you are connected to TournaMAXX or TournaCHAMP, you must re-enter the dial-in settings after completing the software upgrade. After entering the settings, make the initial call into the server, and then perform two **Updates From Server**. Refer to the MegaNet manual for information on how to perform these functions.

Rx Games

1. If you are connected to TournaMAXX or TournaCHAMP you must perform an **Update From Server** before removing the hard drive so that no information is deleted.
2. Turn off and unplug the game.
3. Unlock the game and open it by pulling the rear of the top bezel forward.
4. Disconnect the hard drive data cable and hard drive power cable from the hard drive (see Figure 10).
5. Remove the screw securing the hard drive mounting bracket to its mounting plate (see Figure 10). Remove the hard drive from its mounting plate by sliding the assembly toward the front of the system.
6. Reattach the hard drive data and power cables to the new hard drive (see Figure 10).
7. Slide the hard drive assembly back onto the mounting plate and secure in place with the supplied screw (see Figure 10). If you are **not** installing a security key, skip to step 9.
8. Locate the security key (the button-shaped disc with the handle) on the I/O board (see Figure 10). Remove the existing key from the I/O board by sliding it out of place. Slide the new security key into place.
9. Press the button on the monitor support arm to release the arm, then close and lock the top bezel.
10. Plug in and turn on the game. The game will reboot twice to configure the hardware. When prompted, perform a touchscreen calibration.
11. If you are connected to TournaMAXX or TournaCHAMP you must re-enter the dial-in settings after completing the software upgrade. After entering the settings, make the initial call into the server and then perform two **Updates From Server**. Refer to the MegaNet manual for information on how to perform these functions.

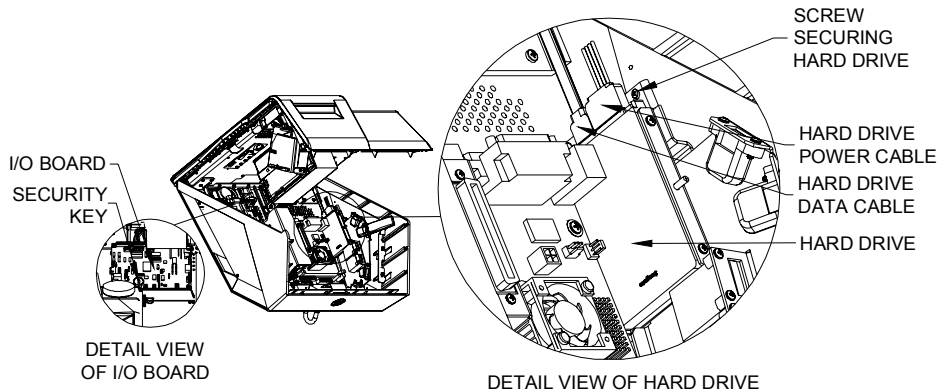

FIGURE 10 - OPENED RX CABINET

Standard Aurora Games

(for Widescreen games, skip to page 12)

1. If you are connected to TournaMAXX or TournaCHAMP, you must perform an **Update From Server** before removing the hard drive so that no information is deleted.
2. Turn off and unplug the game.
3. Unlock and remove/open the rear door.
4. Using Figures 3-4, determine which hard drive assembly you currently have in your game. If you have a PATA hard drive, continue with step 5a; if you have a SATA hard drive, continue with step 6a.

PATA hard drives ONLY:

- 5a. Disconnect the hard drive adapter (with its attached cabling) from the hard drive (see Figures 3 and 11).
- 5b. Disconnect and remove the IDE cable and the 2-pin to 4-pin power cable from the game (they will not be reused). Connect one end of the provided SATA power cable to this now free 4-pin power connector in the game.
- 5c. Remove the screw securing the hard drive mounting bracket to its mounting plate (see Figure 11) and slide the hard drive up and off the mounting plate.
- 5d. Install the new hard drive onto the mounting plate and secure it with the provided screw.
- 5e. Connect the free end of the SATA power cable (installed in step 5b) to the hard drive as shown in Figure 4. Connect the provided SATA data cable to the hard drive (see Figure 4) and connect the other end of this cable to the "SATA 1" header on the motherboard (see Figure 2). Continue with step 7.

SATA hard drives ONLY:

- 6a. Disconnect the SATA power cable and SATA data cable from the hard drive (see Figure 4).
 - 6b. Remove the screw securing the hard drive mounting bracket to its mounting plate (see Figure 11) and slide the hard drive up and off the mounting plate.
 - 6c. Install the new hard drive onto the mounting plate and secure it with the provided screw.
 - 6d. Reconnect the SATA power and data cables as shown in Figure 4.
-
7. If you are **not** installing a security key skip to step 9.
 8. Locate the security key (the button-shaped disc with the handle) on the OSD board (see Figure 11). Remove the existing security key from the OSD board by sliding it out of place. Replace it with the supplied security key.
 - 9a. To install the new marquee, reach under the center of the top rear cover of the unit and turn the latch counterclockwise to disengage. Loosen the thumbscrew securing the bottom of the rear cover (see Figure 11).
 - 9b. Slowly lift the cover and disconnect the ground wire attached to the inside.
 - 9c. **For 19" models** - remove the nut and washer on the center security bolt inside the chassis (see Figure 11).
For 17" models - remove the center security screw inside the chassis (see Figure 11).
 - 9d. Use a Phillips screwdriver to remove the screw at the top-middle of the marquee, then use 7/64" Allen wrench to remove the two screws on the rear of the monitor bezel. Open the bezel away from the chassis (see Figure 11).

- 9e. Remove the remaining two torx screws from the marquee (size T9). This will loosen the LED bracket on the inside of the bezel. **On 17" models** this will also disconnect the strain relief cord, so be sure to support the bezel while removing the screws. Also, please note that the nut securing the strain relief cord to the LED bracket on 17" models will come undone when the screws are loosened.
 - 9f. Replace the marquee with the new one, then tighten the two side screws on the marquee, securing the LED bracket (and the strain relief cord on 17" models). Close the bezel and replace the middle screw on the marquee.
 - 9g. Replace the two screws on the rear of the bezel, then replace the center security screw inside 17" models, or the washer/nut inside 19" models.
 - 9h. Reconnect the ground wire to the rear cover and lower the cover into place, carefully lining up the 2 tabs on the cover with the 2 mating holes on the sides of the game. Make sure that the plastic lip on the bottom of the rear cover is behind the metal base. Tighten the thumbscrew securing the bottom of the rear cover. Turn the wing on the draw latch under the rear hood clockwise to engage the latch.
 - 9i. Close (or reattach) and lock the rear door.
10. Plug in and turn on the game. The game will reboot twice to configure the hardware. When prompted, perform a touch-screen calibration.
 11. If you are connected to TournaMAXX or TournaCHAMP, you must re-enter the dial-in settings after completing the software upgrade. After entering the settings, make the initial call into the server, and then perform two **Updates From Server**. Refer to the MegaNet manual for information on how to perform these functions.

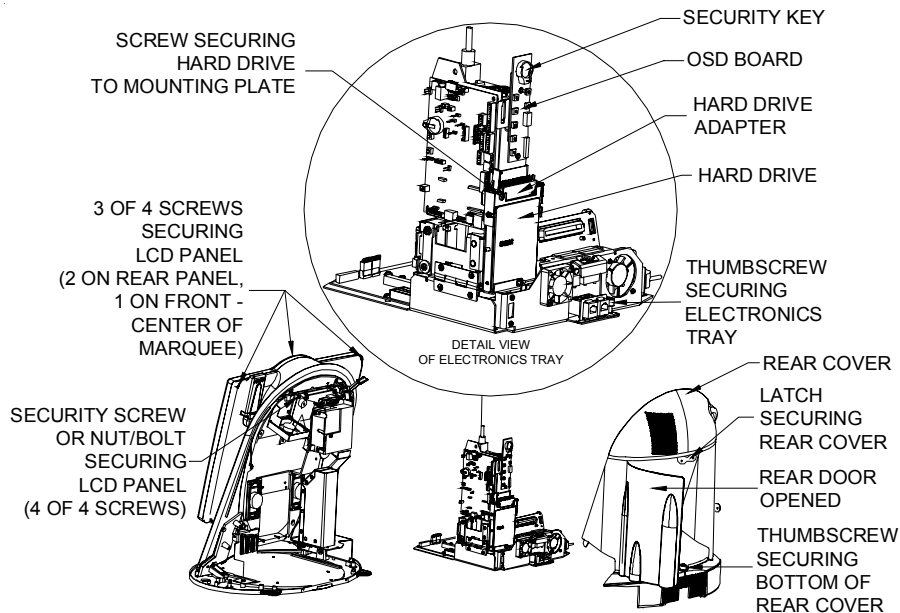

FIGURE 11 - REAR VIEW OF AURORA GAME

Aurora Widescreen Games

1. If you are connected to TournaMAXX or TournaCHAMP, you must perform an **Update From Server** before removing the hard drive so that no information is deleted.
2. Turn off and unplug the game.
3. Unlock and open the rear door.
4. Remove the screw securing the hard drive mounting bracket to its mounting plate (see Figure 12). This screw will not be reused.
5. Remove the hard drive from its mounting plate by sliding the assembly up and off the mounting plate. Disconnect the data cable and power cable from the hard drive (see Figure 4).
6. Attach the hard drive data cable and hard drive power cable in the game to the new hard drive. See Figure 4.
7. Slide the new hard drive assembly onto the game's mounting plate. Be sure that the hard drive is flush to the mounting plate when doing so. Align the hole in the mounting bracket with the hole on the mounting plate, then secure the hard drive assembly with the provided screw. If you are **not** installing a security key skip to step 10.
8. Locate the security key (the button-shaped disc with the handle) on the OSD board (see Figure 12).
9. Remove the existing security key from the OSD board by sliding it out of place. Replace it with the supplied security key.
- 10a. To install the new marquee, reach under the center of the top rear cover of the unit and turn the latch counterclockwise to disengage. Loosen the thumbscrew securing the bottom of the rear cover (see Figure 12).
- 10b. Slowly lift the cover and disconnect the ground wire attached to the inside.
- 10c. Remove the nut and washer on the center security bolt inside the chassis (see Figure 12).
- 10d. Use a Phillips screwdriver to remove the screw at the top-middle of the marquee, then use 7/64" Allen wrench to remove the two screws on the rear of the monitor bezel. Open the bezel away from the chassis (see Figure 12).
- 10e. Remove the remaining two torx screws from the marquee (size T9). This will loosen the LED bracket on the inside of the bezel.
- 10f. Replace the marquee with the new one, then tighten the two side screws on the marquee, securing the LED bracket. Close the bezel and replace the middle screw on the marquee.
- 10g. Replace the two screws on the rear of the bezel, then replace the washer/nut inside the unit (see Figure 12).

- 10h. Reconnect the ground wire to the rear cover and lower the cover into place, carefully lining up the 2 tabs on the cover with the 2 mating holes on the sides of the game. Make sure that the plastic lip on the bottom of the rear cover is behind the metal base. Tighten the thumbscrew securing the bottom of the rear cover. Turn the wing on the draw latch under the rear hood clockwise to engage the latch.
- 10i. Close and lock the rear door.
11. Plug in and turn on the game. The game will reboot twice to configure the hardware. When prompted, perform a touch-screen calibration.
12. If you are connected to TournaMAXX or TournaCHAMP, you must re-enter the dial-in settings after completing the software upgrade. After entering the settings, make the initial call into the server, and then perform two **Updates From Server**. Refer to the MegaNet manual for information on how to perform these functions.

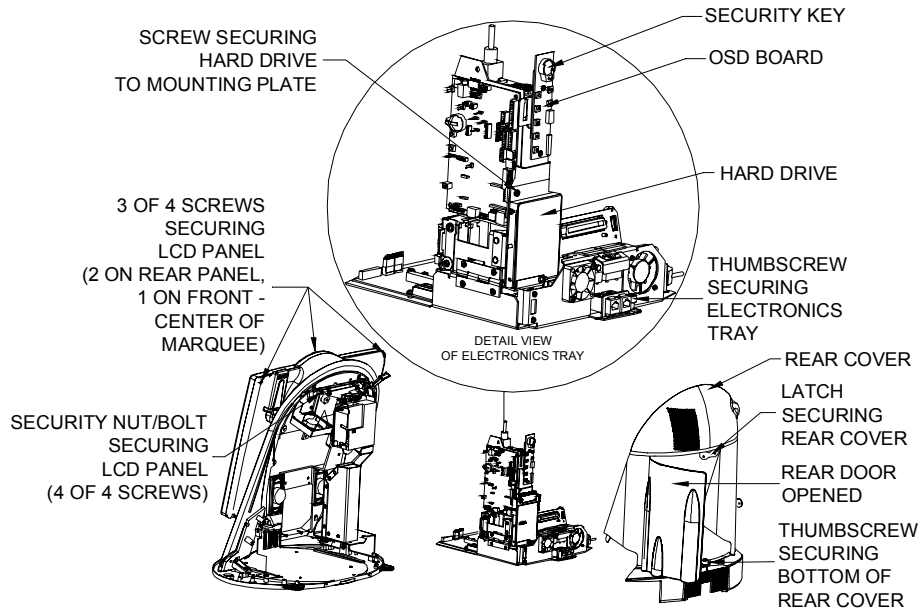

FIGURE 12 - REAR VIEW OF AURORA WIDESCREEN GAME

AMI Entertainment Network, Inc. Software License Agreement

AMI Entertainment Network, Inc. ("Licensor") is willing to license the enclosed software to you only if you accept all of the terms in this license agreement ("Agreement").

Ownership of the Software

1. The enclosed Megatouch® product, which may include but is not limited to the Megatouch software program ("Software") and the accompanying written materials, are owned by Licensor and are protected by United States copyright laws, patent laws and other intellectual property laws, by laws of other nations, and by international treaties.

Restrictions on Use and Transfer

2. If this Software package contains multiple media types (such as CDs, flash cards, hard drives, etc), then you may use only the type of media appropriate for your Machine. You may not use the other media types on another Machine, or transfer, or assign them to another user except as part of the permanent transfer of the Software and all written materials (as provided for below in paragraph 4).
3. You may make one copy of the software for backup purposes only. You may not copy or make backup copies of any software security key or software security device under any circumstances.
4. You may permanently transfer the right to use the Software and accompanying written materials (including the most recent update and all prior versions) if you retain no copies and the transferee agrees in writing to be bound by the terms of this Agreement. Such a transfer of this license to another party immediately terminates your license. You may not otherwise transfer or assign the right to use the Software, except as stated in this paragraph.
5. You may not operate or allow the operation of the Software at locations where the operation of such Software does not comply with all local, state, and other governmental body laws and regulations. You agree to not use or permit the use of the Software in violation of any U.S. Federal, state, or local laws or regulations or any foreign law or regulation, including laws regarding gaming, gambling or intellectual property rights in or concerning the Software.
6. You may not modify, adapt, translate, reverse engineer, decompile, disassemble the Software or create derivative works from the Software or any component thereof; nor may you remove, modify or hide or otherwise make unreadable or non-viewable any notice, legend, advice, watermark or other designation contained on the Software, component thereof, or output therefrom.
7. You agree that the Software and the authorship, systems, ideas, inventions methods of operation, documentation and other information contained therein, and all versions, modifications and adaptations thereto are proprietary intellectual properties of Licensor and are protected by civil and criminal law, and by copyright, trade secret, trademark and the patent laws of the United States and other countries.

Limited Warranty

8. Licensor warrants, solely for your benefit, that the Software will function in material conformity, with its accompanying documentation for a period outlined in Licensor's standard product warranty period after your receipt of the Software.

Licensor's Obligations Under Warranty

9. Licensor's sole obligation under the aforesaid warranty shall be to utilize commercially reasonable efforts to correct or modify such portion of the Software as to make it materially conform with the applicable documentation.

Grant Of License

10. Licensor grants to you a limited, non-exclusive license to distribute and/or use one copy of the Software on a single Megatouch ("Machine") accompanied by a single licensor factory authorized security key. Licensor reserves the right to update versions of the software and the content to the Machine as deemed appropriate by the Licensor. You are entrusted to maintain and protect your single licensor factory authorized security key, password, or other identification from being utilized by any third party, and you agree to be responsible for any use of the Software provided herein by a third party utilizing your identification. Licensor maintains the right to immediately terminate your License for reasons related to misuse or other non-conformity with the rules expressed herein. While Licensor does not routinely inspect Machines, Licensor also reserves the right to inspect or audit the Software from time to time in Licensor's sole discretion. To the extent that Licensor's access to the Software requires that Licensor also gain access to a Machine in which the Software is installed, you agree to promptly provide Licensor, when requested, with permission and aid in Licensor gaining access to the Machine.

Disclaimers

11. EXCEPT AS PROVIDED IN THE SECTION ENTITLED "LIMITED WARRANTY", LICENSOR MAKES NO OTHER PROMISES, REPRESENTATIONS OR WARRANTIES, WHETHER EXPRESSED OR IMPLIED, REGARDING OR RELATING TO THE SOFTWARE OR CONTENT THEREIN OR TO ANY OTHER MATERIAL FURNISHED OR PROVIDED TO YOU PURSUANT TO THIS AGREEMENT OR OTHERWISE AND LICENSOR SPECIFICALLY DISCLAIMS ALL IMPLIED WARRANTIES OF MERCHANTABILITY AND FITNESS FOR A PARTICULAR PURPOSE WITH RESPECT TO SAID MATERIALS OR THE USE THEREOF. TO THE MAXIMUM EXTENT ALLOWABLE BY LAW THE UNIFORM COMMERCIAL CODE OR OTHER UNIFORM LAWS SHALL NOT APPLY TO THIS AGREEMENT.

Limitation on Liability

12. IN NO EVENT SHALL LICENSOR BE LIABLE UNDER ANY CLAIM, DEMAND OR ACTION ARISING OUT OF OR RELATING TO THE SOFTWARE, ITS USE, INSTALLATION OR LICENSOR'S PERFORMANCE OR LACK THEREOF UNDER THIS AGREEMENT FOR ANY SPECIAL, INDIRECT, INCIDENTAL, EXEMPLARY OR CONSEQUENTIAL DAMAGES, WHETHER OR NOT LICENSOR HAS BEEN ADVISED OF THE POSSIBILITY OF SUCH CLAIM, DEMAND OR ACTION. IN ADDITION, WITHOUT LIMITING THE FOREGOING, IN ALL EVENTS THE REMEDIES AVAILABLE TO YOU SHALL BE LIMITED TO THE AMOUNT PAID BY YOU TO LICENSOR FOR THE SOFTWARE.
13. IN NO EVENT WILL LICENSOR BE LIABLE TO YOU FOR DAMAGES, INCLUDING ANY LOSS OF PROFITS, LOST SAVINGS, OR OTHER INCIDENTAL OR CONSEQUENTIAL DAMAGES ARISING OUT OF YOUR USE, MISUSE, BREACH OF THIS AGREEMENT OR INABILITY TO USE THE SOFTWARE.

General

14. The validity and construction of this Agreement and of the rights and obligations herein shall be determined and governed by the laws of the State of New York. By accepting the terms of this Agreement, you acknowledge and accept that the courts of New York, New York shall have exclusive jurisdiction and venue regarding any disputes arising with regard to this Agreement or arising out of activity or misuse of the Software.
15. AMI Entertainment Network, Inc. in its sole discretion, may assign this agreement or any of its rights and obligations hereunder.
16. If you have any questions concerning this Agreement or wish to contact Licensor for any reason, please write: AMI Entertainment Network, Inc., 155 Rittenhouse Circle, Bristol, PA 19007, USA.

Contrat de licence de logiciel de AMI Entertainment Network, Inc.

AMI Entertainment Network, Inc. (ci-après le "Concédant") est disposé à vous accorder la licence d'utilisation du logiciel ci-inclus, à condition que vous vous engagiez à respecter tous les termes, clauses et conditions du présent contrat de licence (Contrat).

Droit de Propriété

1. Le produit Megatouch® ci-joint contenant, mais ne s'y limitant pas, le logiciel Megatouch (ci-après le "logiciel") et toute la documentation écrite, restent la propriété du Concédant et sont protégés par : les lois de droits d'auteur des Etats-Unis, les lois s'appliquant aux brevets déposés et à la propriété intellectuelle, ainsi que par celles des autres pays et les traités internationaux.

Restriction d'Utilisation et Transfert

2. Si le présent logiciel comprend plusieurs types de composants (tels que CD-ROM, cartes flash, disques durs, etc), vous ne pouvez utiliser que ceux qui conviennent à votre appareil. Il est strictement interdit de les utiliser sur un autre appareil, les transférer -ou les céder à un autre utilisateur, sauf en cas de transfert permanent du logiciel et de toute la documentation écrite (comme indiqué ci-dessous au paragraphe 4).
3. Il est interdit de copier le logiciel, à l'exception d'une copie de sauvegarde. Il est aussi interdit de reproduire -ou faire des copies de sauvegarde des programmes de clé de sécurité ou autres fichiers de sécurité, quelles que soient les circonstances.
4. Vous pouvez céder en permanence à un tiers -le droit d'utiliser le LOGICIEL et toute la documentation écrite l'accompagnant, (ainsi que la plus récente mise à jour et toutes autres anciennes versions) seulement si vous n'en gardez aucune copie, et si le cessionnaire s'engage, par écrit, à respecter les termes, clauses et conditions du présent Contrat. Cette cession à un tiers met fin à votre licence immédiatement. Autrement, vous n'avez pas la permission de transférer ou d'accorder à un tiers le droit d'utiliser le présent logiciel, excepté que tel que décrit dans le présent paragraphe.
5. Il est interdit d'utiliser le présent logiciel ou de permettre son utilisation dans des emplacements où l'utilisation du présent logiciel n'est pas conforme aux lois et réglementations locales, nationales ou réglementations d'autres organismes gouvernementaux. Vous acceptez de ne pas utiliser ou d'autoriser l'utilisation du logiciel d'une manière enfreignant les lois ou réglementations s'appliquant à la propriété intellectuelle et au jeu, en vigueur aux Etats-Unis ou dans les autres pays du monde, y compris les lois de l'ensemble du logiciel.
6. Il est interdit de modifier, adapter, traduire, démonter, décompiler, désassembler le logiciel ou créer du matériel dérivé du logiciel ou de tout composant de celui-ci ; vous ne pouvez pas enlever, modifier ou cacher ou rendre illisible ou non-visible toute instruction, légende, information ou filigrane ou autre désignation qui apparaît dans le logiciel, composant dudit logiciel ou résultant dudit logiciel.
7. Vous convenez que le logiciel et les droits d'auteur, les systèmes, les idées, les inventions, les méthodes d'utilisation, la documentation et autre information incluse, ainsi que toutes les versions, modifications et adaptations qui s'y rattachent sont les propriétés intellectuelles du Concédant et sont protégées par le droit civil et pénal et par le droit d'auteur, le secret commercial, la marque déposée et le brevet aux Etats-Unis et dans les autres pays du monde.

Limite de Garantie

8. Le Concédant garantit seulement à votre intention, que le logiciel permettra une utilisation conforme, avec la documentation l'accompagnant, pendant la période de temps indiquée dans la période de garantie du produit standard du Concédant, à compter de la date de livraison du logiciel.

Responsabilité du Concédant aux termes de la Garantie

9. La seule obligation du Concédant aux termes de la garantie susmentionnée sera de faire tous les efforts commercialement raisonnables pour corriger ou modifier la partie du logiciel pour le rendre matériellement conforme aux spécifications de la documentation.

Concession de Licence

10. Le Concédant vous accorde le droit d'utiliser une seule copie par appareil Megatouch (ci-après "Appareil") accompagné d'une seule clé de sécurité autorisée en usine et fournie par le Concédant. Le Concédant se réserve le droit de mise à jour des versions du logiciel et du contenu de l'Appareil, quand il juge nécessaire de le faire. Il vous appartient également d'empêcher que les mots de passe ou autres codes et la clé de sécurité soient utilisés par un tiers. Vous acceptez d'assumer la responsabilité dans le cas de l'utilisation du logiciel par un tiers. Le Concédant se réserve le droit de résilier votre contrat de licence à tout moment dans l'éventualité d'une utilisation non-conforme aux clauses stipulées. Bien que le Concédant ne contrôle pas les appareils périodiquement, il se réserve toutefois le droit de contrôler le logiciel à tout moment et sans préavis de sa part. De surcroît, dans l'éventualité où le logiciel n'est accessible qu'à travers la machine dans laquelle il est installé, le licencié s'engage à donner libre accès au Concédant, ou ses représentants, à la machine et dans les plus brefs délais.

Exclusion de toute autre garantie

11. EXCEPTÉ COMME PRÉVU DANS LA SECTION INTITULÉE "LIMITE DE GARANTIE", LE CONCEDANT N'ASSURE AUCUNE AUTRE GARANTIE DE QUELQUE NATURE ET À QUELQUE TITRE QUE CE SOIT, EXPLICITE OU IMPLICITE, EN RAPPORT AVEC LE LOGICIEL ET LES COMPOSANTS QUI L'ACCOMPAGNENT OU, LE CAS ÉCHÉANT, TOUT SUPPORT OU MATÉRIEL FOURNI CONFORMÉMENT AU PRÉSENT CONTRAT EN PARTICULIER, LE CONCEDANT NE PEUT DONNER AUCUNE GARANTIE, DE QUELQUE NATURE QUE CE SOIT, POUR LA COMMERCIALISATION DE TOUS LES PRODUITS EN RAPPORT AVEC LE LOGICIEL OU AVEC L'UTILISATION DE CELUI-CI. DANS LA MESURE OU CELA EST PERMIS PAR LA LOI, LE CODE UNIFORME COMMERCIAL OU AUTRE LOI UNIFORME NE S'APPLIQUE PAS AU PRÉSENT CONTRAT.

Limite de Responsabilité

12. LE CONCEDANT NE SERA EN AUCUN CAS RESPONSABLE DE TOUTE RECLAMATION, DEMANDE OU ACTION RESULTANT DE OU EN RAPPORT AVEC LE LOGICIEL, SON UTILISATION OU SON INSTALLATION, OU LA PERFORMANCE OU MANQUE DE PERFORMANCE DU CONCEDANT EN VERTU DU PRÉSENT CONTRAT POUR TOUS DOMMAGES D'UNE NATURE QUI N'EST PAS PRÉSUMÉE PAR LA LOI ET QUI DOIVENT ÊTRE EXPRESSEMENT Prouvés, DOMMAGE INDIRECTS, DOMMAGES-INTERETS POUR PRÉJUDICE MORAL, QUE LE CONCEDANT AIT ÉTÉ AVISÉ OU NON DE LA POSSIBILITÉ D'UNE TELLE RECLAMATION, DEMANDE OU ACTION. DE PLUS, SANS LIMITER CE QUI PRÉCÈDE, LES DÉDOMMAGEMENTS À VOTRE DISPOSITION SERONT LIMITÉS AU MONTANT QUE VOUS AUREZ PAYÉ AU CONCEDANT POUR LE LOGICIEL.
13. LE CONCEDANT NE SERA EN AUCUN CAS RESPONSABLE : D'UNE RUPTURE DE CONTRAT, DES DOMMAGES, Y COMPRIS TOUTE PERTE DE PROFIT, PERTES D'ÉCONOMIE OU TOUS AUTRES DOMMAGES INDIRECTS OU DOMMAGES-INTERETS ACCESSOIRES DECOULANT DE LA MAUVAISE UTILISATION OU DE L'IMPOSSIBILITÉ D'UTILISATION DU LOGICIEL.

Dispositions Générales

14. La validité et la construction du présent Contrat et les droits et obligations ci-inclus seront déterminés et régis par les lois de l'état de New York aux États-Unis. En acceptant les dispositions du présent contrat, vous acceptez également que tous litiges ou revendications relatives seront réglés par voie d'arbitrage par un tribunal de l'état de New York, aux États-Unis.
15. AMI Entertainment Network, Inc. réserve le droit de transférer le présent Contrat à un tiers ainsi que ses droits et obligations ci-après.
16. Pour toutes questions concernant le présent Contrat -ou si vous désirez contacter le Concédant pour une raison quelconque, veuillez écrire à : AMI Entertainment Network, Inc., 155 Rittenhouse Circle, Bristol, PA 19007, États-Unis.

AMI Entertainment Network, Inc. Softwarelizenzabkommen

AMI Entertainment Network, Inc. („Lizenzgeber“) ist nur dann bereit Ihnen eine Lizenz für die beiliegende Software zu erteilen, wenn Sie alle Bestimmungen dieses Lizenzabkommens („Abkommen“) akzeptieren.

Eigentumsvorbehalt der Software

1. Das beiliegende Megatouch®-Produkt, welches das Megatouch Softwareprogramm („Software“) beinhalten kann, aber nicht darauf beschränkt ist, und die schriftlichen Unterlagen sind Eigentum des Lizenzgebers und sind durch die Gesetze der Vereinigten Staaten und anderer Länder und durch internationale Verträge urheberrechtlich geschützt.

Beschränkungen im Gebrauch und Transfer

2. Sollte diese Softwarelieferung mehrere Medien enthalten (z.B. CD, Karten, Festplatten usw.), dürfen Sie nur die für Ihre Maschine angebrachte Medienart verwenden. Die anderen Medienarten dürfen nicht auf anderen Maschinen verwendet werden oder an Dritte übergeben werden, abgesehen von einem endgültigen Transfer der Software und aller schriftlichen Unterlagen (wie im untenstehenden Paragraphen 4 beschrieben).
3. Sie dürfen nur eine Sicherungskopie der Software herstellen. Unter keinen Umständen dürfen Sie einen Softwaresicherungsschlüssel oder Sicherungsmaßnahmen kopieren oder davon Sicherungskopien herstellen.
4. Sie dürfen das Nutzungsrecht für die Software und die schriftlichen Unterlagen (einschließlich der aktuellen Version und aller vorhergehenden Versionen) an Dritte übertragen, wenn Sie keine Kopie behalten und wenn der Empfänger die Bestimmungen dieses Abkommens in schriftlicher Form akzeptiert. Bei einem solchen Transfer der Lizenz an Dritte erlischt Ihre Lizenz umgehend. Abgesehen von den Bestimmungen dieses Paragraphen sind alle anderen Transfers oder Übertragungen der Nutzungsrechte für diese Software unerlaubt.
5. Sie dürfen die Software nicht benutzen oder eine Nutzung gestatten, wenn eine solche Nutzung der Software irgendwelche Gesetze und Verordnungen der kommunalen oder staatlichen Behörden verletzen würde. Sie verpflichten sich die Software nicht so zu nutzen oder nutzen zu lassen, dass sie damit gegen staatliche, Bundes- oder Lokalgesetze oder Bestimmungen der USA oder gegen ausländische Gesetze oder Bestimmungen, einschliesslich aller Gesetze bezüglich Glücksspiels, Spielens oder geistigen Eigentumsrechts der Software, verstossen.
6. Es ist Ihnen nicht gestattet, die Software abzuändern, zu verändern, zu übersetzen, rückumzuwandeln, zu dekompileieren oder zu zerlegen, oder aus der Software oder eines Teils davon andere Werke abzuleiten. Sie dürfen auch aus der Software, einem Bestandteil der Software oder aus den Datenausgaben der Software keine Hinweise, Bemerkungen, Ratschläge, Wasserzeichen oder andere Markierungen entfernen, verändern, verbergen oder auf andere Art unlesbar machen.
7. Sie akzeptieren, dass die Software und die Urheberschaft, die Systeme, die Ideen, Erfindungen, die Arbeitsweisen, die Dokumentation und alle anderen darin enthaltenen Informationen und alle Versionen, Veränderungen, und Bearbeitungen davon das geistige Eigentum des Lizenzgebers sind, und dass sie durch Straf- und Zivilgesetzgebung und durch die Copyright-, Geschäftsgeheimnis-, Warenzeichen- und die Patentgesetze der Vereinigten Staaten und anderer Länder geschützt sind.

Beschränkte Garantie

8. Der Lizenzgeber garantiert zu Ihren Gunsten, dass die Software für die angegebene normale Garantiezeit des Lizenzgebers nach Ihrer Annahme der Software in erheblicher Übereinstimmung mit der beiliegenden Dokumentation laufen wird.

Verpflichtung des Lizenzgebers im Rahmen der Garantie

9. Die ausschließliche Pflicht des Lizenzgebers im Rahmen der vorstehenden Garantie besteht darin, alle geschäftlich vertretbaren Schritte zu unternehmen, um Teile der Software zu berichtigen oder abzuändern, bis sie mit der beiliegenden Dokumentation erheblich übereinstimmen.

Übertragung der Lizenz

10. Der Lizenzgeber gewährt Ihnen eine beschränkte, nicht-ausschliessbare Lizenz zur Vertreibung und/oder Benutzung einer Kopie der Software auf einem einzelnen Megatouch („Gerät“) mit einem einzelnen werksmässig gestatteten Sicherheitsschlüssel. Der Lizenzgeber behält sich das Recht vor, nach eigenem Ermessen die Software und den Inhalt der Maschine zu verbessern. Sie sind dafür verantwortlich ihren individuellen, vom Lizenzgeber werksmässig gestatteten Sicherheitsschlüssel, ihr Passwort oder anderweitigen Identifikationsmechanismus instandzuhalten und abzusichern gegen die Nutzung durch eine dritte Partei, und sie akzeptieren die Verantwortung für jegliche Nutzung der besagten Software durch eine dritte Partei mithilfe ihres Identifikationsmechanismus. Obwohl der Lizenzgeber nicht regelmässig Maschinen inspiziert, behält sich der Lizenzgeber das Recht vor, ihre Lizenz umgehend zu kündigen aus Gründen des Missbrauchs oder bei Nichtbefolgung der Bestimmungen in diesem Vertrag. Der Lizenzgeber behält sich ebenfalls das Recht vor, die Software von Zeit zu Zeit nach eigenem Ermessen zu inspizieren oder zu überprüfen. Im Falle, dass der Lizenzgeber Zugang zu dem Gerät wünscht, in dem besagte Software installiert ist, erklären Sie sich bereit, dass sie dem Lizenzgeber, wenn nötig, Erlaubnis und Hilfe beim Zugang zum Gerät verschaffen.

Beschränkungen

11. ABGESEHEN VON DEN BESTIMMUNGEN DES PARAGRAPHEN „BESCHRÄNKTE GARANTIE“ GIBT DER LIZENZGEBER KEINE SONSTIGEN VERSPRECHEN, VERPFLICHTUNGEN ODER GARANTIEEN, OBAUSDRÜCKLICH ODER STILLSCHWEIGEND, FÜR DIE SOFTWARE ODER IHRE BESTANDTEILE ODER FÜR ALLE ANDEREN MATERIALIEN, DIE IHNEN IM RAHMEN DIESES ABKOMMENS ZUR VERFÜGUNG GESTELLT ODER ÜBERLASSEN WERDEN, UND DER LIZENZGEBER LEHNT AUSDRÜCKLICH ALLE ANSPRÜCHE AUF MARKTFÄHIGKEIT UND EIGNUNG DER BESAGTEN MATERIALIEN FÜR DEN GEWÖHNLICHEN GEBRAUCH AB. SOWEIT GESETZESMÄSSIG ZUGELASSEN, SOLLEN DIE HANDELSRECHTLICHE GESETZGEBUNG AUS DEM UNIFORM COMMERCIAL CODE ODER ANDERE GESETZE AUF DIESES ABKOMMEN NICHT ANWENDBAR SEIN.

Haftungsbeschränkung

12. DER LIZENZGEBER HAT KEINERLEI HAFTUNG BEI EINEM ANSPRUCH, EINER FORDERUNG ODER EINER KLAGE, DIE AUF NUTZUNG DER SOFTWARE, DEREN INSTALLIERUNG, DER LEISTUNG DES LIZENZGEBERS ODER DESSEN VERSAGEN IM RAHMEN DIESES ABKOMMENS FÜR JEGLICHE FOLGE-, INDIREKTE, SONDER- ODER NEBENSCHÄDEN BERUHEN, SELBST WENN DER LIZENZGEBER AUF DIE MÖGLICHKEIT EINES SOLCHEN ANSPRUCHES, EINER FORDERUNG ODER EINER KLAGE HINGEWIESEN WURDE. WEITERHIN UND OHNE BESCHRÄNKUNG DES LETZTEN SATZES, DÜRFEN IN ALLEN FÄLLEN DIE IHNEN ZUR VERFÜGUNG STEHENDEN ABHILFEN DIE VON IHNEN FÜR DIE SOFTWARE AN DEN LIZENZGEBER GEZAHLTE SUMME NICHT ÜBERSCHREITEN.
13. DER LIZENZGEBER HAT IN KEINEM FALLE EINE HAFTUNG IHNEN GEGENÜBER FÜR SCHÄDEN, EINSCHLIESSLICH ETWAIGER GEWINNVERLUSTE, NICHT REALISIERTE EINSPARUNGEN ODER ANDERER NEBEN- ODER FOLGESCHÄDEN, DIE AUS IHRER VERWENDUNG, MISSBRAUCH, VERLETZUNG DIESES ABKOMMENS ODER GEBRAUCHSUNFÄHIGKEIT DER SOFTWARE ENTSTEHEN.

Allgemein

14. Die Rechtsgültigkeit und Provisionen dieses Abkommens und der darin enthaltenen Rechte und Pflichten werden durch die Gesetze des Staates von New York bestimmt. Sollten sie diese Vereinbarungen annehmen, dann akzeptieren Sie, dass der ausschliessliche Erfüllungsort und Gerichtsstand bei den Gerichten von New York im Staat New York liegen hinsichtlich aller Streitigkeiten, die diesen Vertrag betreffen, oder die durch Leistung oder Missbrauch der besagten Software entstehen.
15. AMI Entertainment Network, Inc. kann nach eigenem Ermessen dieses Abkommen oder jedes der darin enthaltenen Rechte und Pflichten an Dritte abtreten.
16. Bei Rückfragen über dieses Abkommen oder wenn Sie den Lizenzgeber aus einem anderen Grund kontaktieren wollen, bitte schreiben an: AMI Entertainment Network, Inc., 155 Rittenhouse Circle, Bristol, PA 19007, USA.

Please read the enclosed license agreement. Operation of this game constitutes acceptance of the AMI Software License Agreement.

Veillez lire le contrat de licence d'utilisation ci-inclus. Si vous utilisez ce jeu, vous vous engagez à respecter les termes et conditions du contrat de licence d'utilisation du logiciel de AMI.

Bitte beiliegendes Lizenzabkommen durchlesen. Das AMI Software Lizenzabkommen tritt in Kraft, sobald dieses Spiel verwendet wird.