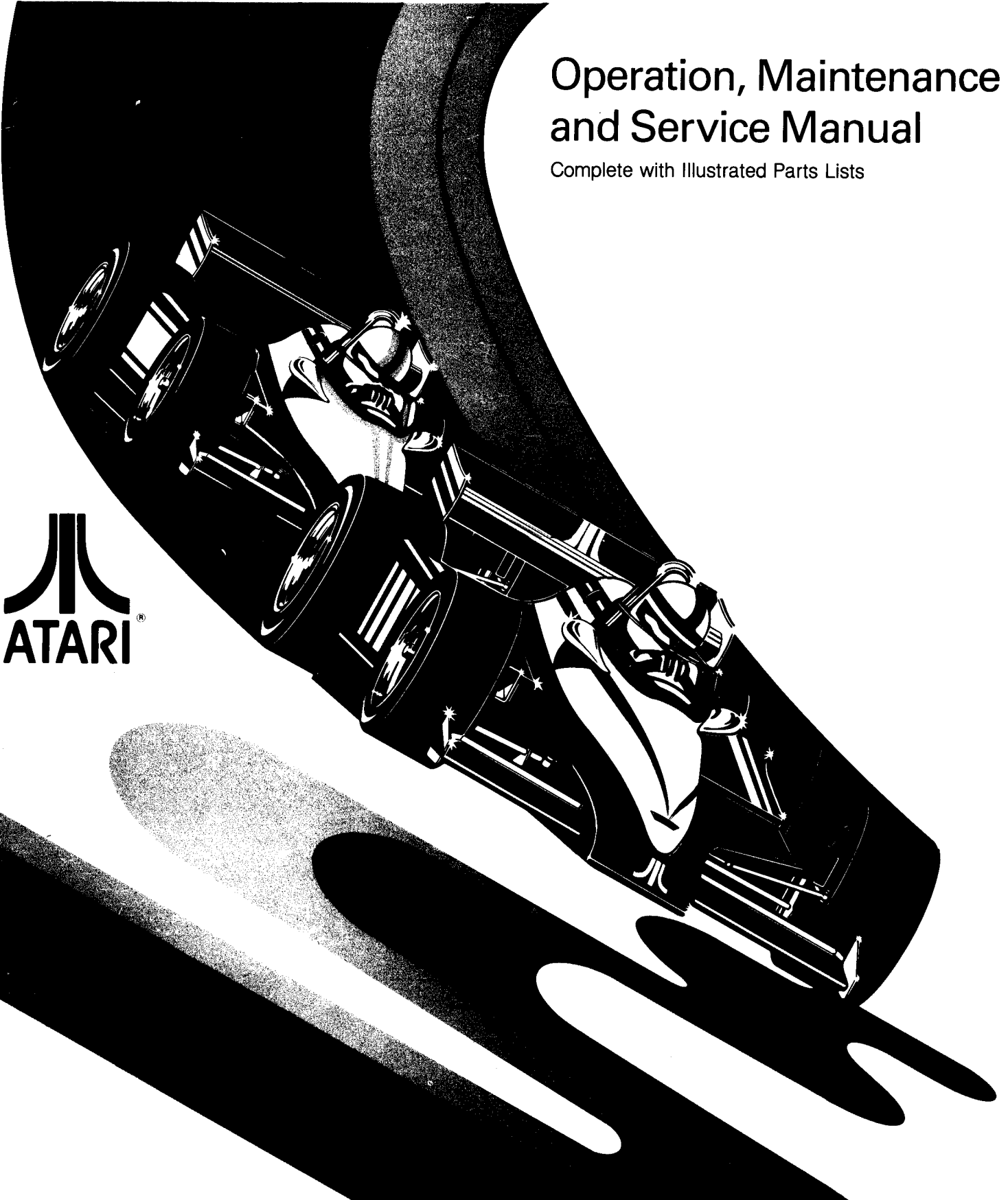
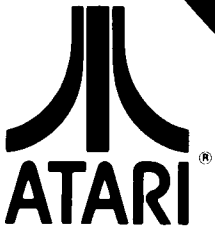


# Monte Carlo™

## Operation, Maintenance and Service Manual

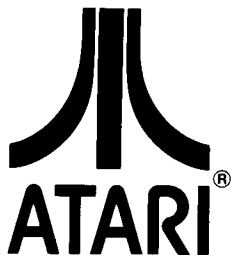
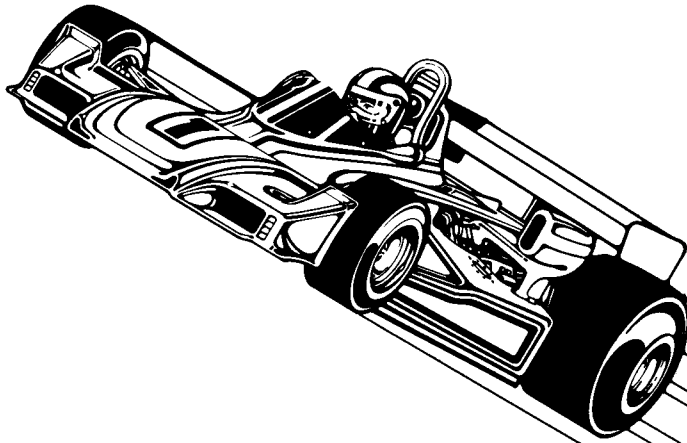
Complete with Illustrated Parts Lists



# MONTÉ CARLO™

## Operation, Maintenance and Service Manual

Complete with Illustrated Parts Lists



Published by:  
**ATARI INC**  
1265 Borregas Avenue  
P. O. Box 427  
Sunnyvale, California 94086

Copyright © 1980 by Atari, Inc. All rights reserved.

No part of this publication may be reproduced by any mechanical, photographic, or electronic process, or in the form of a phonographic recording, nor may it be stored in a retrieval system, transmitted, or otherwise copied for public or private use, without permission from the publisher.

Lithographed in the U.S.A. 4J

 A Warner Communications Company

# Table of Contents

## 1 Location Setup

A. New Parts .....	1
B. Game Inspection .....	3
C. Game Installation .....	3
1. Voltage Selection .....	3
2. Interlock and Power On/Off Switches .....	4
D. Self-Test Procedure .....	4
E. Game Play .....	9
1. Attract Mode .....	9
2. Ready-to-Play Mode .....	9
3. Play Mode .....	9

## 2 Maintenance and Repair

A. Cleaning .....	13
B. Fuse Replacement .....	13
C. Opening the Control Panel .....	13
1. Steering Wheel Maintenance and Repair .....	13
2. LED Switch Replacement .....	13
3. Gear Shifter Maintenance and Repair .....	13
D. TV Monitor Replacement .....	16
E. Printed Circuit Board Replacement .....	17
F. Fluorescent Tube Replacement .....	18
G. Foot Pedal Maintenance and Repair .....	19
H. Coin Door Repairs .....	20
I. Game Operation .....	22

## 3 Illustrated Parts Lists

# List of Illustrations

Figure 1	Overview of Game . . . . .	2
Figure 2	Installation Requirements . . . . .	3
Figure 3	Power Supply . . . . .	4
Figure 4	Interlock and Power On/Off Switches . . . . .	5
Figure 5	Location of Self-Test Switch, Volume Control and Option Switches . . . . .	6
Figure 6	Self-Test Procedure . . . . .	7
Figure 7	Option Switch Settings . . . . .	8
Figure 8	Opening the Control Panel . . . . .	12
Figure 9	Steering Wheel Maintenance and Repair . . . . .	14
Figure 10	LED Switch Testing and Replacement . . . . .	14
Figure 11	Gear Shifter Maintenance and Repair . . . . .	15
Figure 12	TV Monitor Removal . . . . .	16
Figure 13	PCB Replacement . . . . .	17
Figure 14	Fluorescent Tube Replacement . . . . .	18
Figure 15	Foot Pedal Maintenance and Repair . . . . .	19
Figure 16	Removing Coin Mechanism . . . . .	20
Figure 17	Switch and Trip Wire Replacement . . . . .	21
Figure 18	Coin Door Lamp Replacement . . . . .	22
Figure 19A	Monte Carlo wiring Diagram . . . . .	24
Figure 19B	Coin Door Wiring Diagram . . . . .	25
Figure 19C	Fluorescent Light Wiring Diagram . . . . .	27
Figure 20A	Steering PCB Schematic Diagram . . . . .	27
Figure 20B	Power Supply Schematic Diagram . . . . .	28
Figure 20C	Regulator/Audio II PCB Schematic Diagram . . . . .	29
Figure 20D	Game PCB Schematic Diagram . . . . .	30
Figure 21	Final Assembly . . . . .	44
Figure 22	Control Panel Assembly . . . . .	46
Figure 23	Game PCB Assembly . . . . .	47
Figure 24	Regulator/Audio II PCB Assembly . . . . .	52
Figure 25	Steering Wheel Assembly . . . . .	54
Figure 26	Gear Shifter Assembly (“H” Pattern) . . . . .	56
Figure 27	Foot Pedal Control . . . . .	58
Figure 28	Type B Power Supply Assembly . . . . .	60
Figure 29	Fluorescent Light and Speaker . . . . .	62
Figure 30	New Coin Door (2 or 3 Mechanisms) . . . . .	64

## NOTE

If reading through this manual does not lead to solving a certain maintenance problem, call Tele-Help™ at the Atari Customer Service office in your geographical area, as shown in one of the two maps below. Order all parts from the California office.

### WEST and CENTRAL U.S.A.

Parts for all Atari Customers. Sales and Service

Atari Coin-Op Customer Service  
1344 Bordeaux Drive, Sunnyvale, CA 94086  
Telex 17-1103

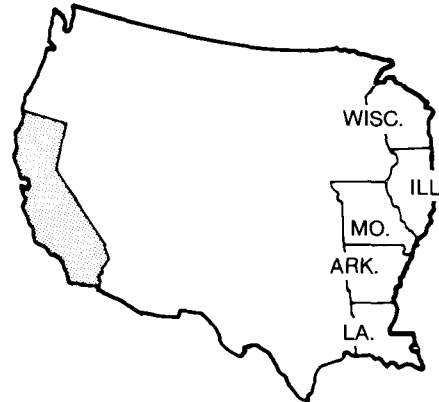
(Monday - Friday, 7:30 - 4:00 pm Pacific Time)



From California, Alaska or Hawaii  
(408) 745-2900



From anywhere else in this area  
toll-free (800) 538-1611



### EAST U.S.A.

Sales and Service Only

Atari Inc.  
New Jersey Customer Service Office  
Cottontail Lane, Somerset, NJ 08873  
Telex 37-9347

(Monday - Friday, 8:30 - 5:00 pm Eastern time)

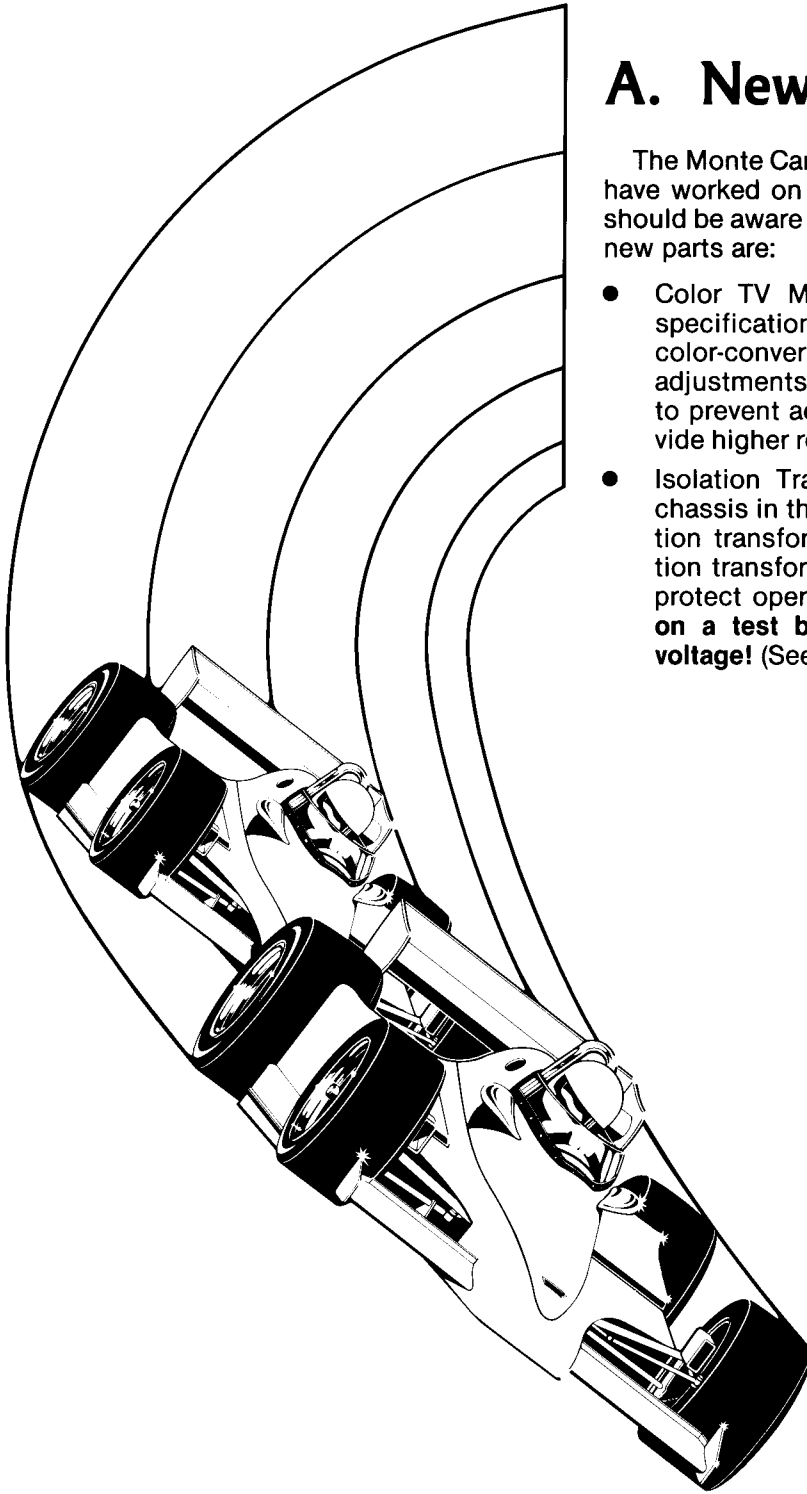


From New Jersey  
(201) 469-5993



From anywhere else in this area  
toll-free (800) 526-3849

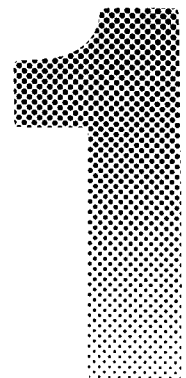




## A. New Parts

The Monte Carlo™ game has five new parts. If you have worked on Atari games in the past, then you should be aware of these important differences. The new parts are:

- Color TV Monitor. Made especially to Atari specifications, the 19-inch monitor has been color-converged at the factory. All convergence adjustments are cemented and locked in place, to prevent accidental changes. This helps provide higher reliability for the service technician.
- Isolation Transformer. The color TV monitor chassis in this game does not contain an isolation transformer. Atari has mounted an isolation transformer on the floor of the cabinet to protect operators. **If you service this color TV on a test bench, you must isolate the line voltage!** (See instructions on pages 16 and 17.)



# Location Setup

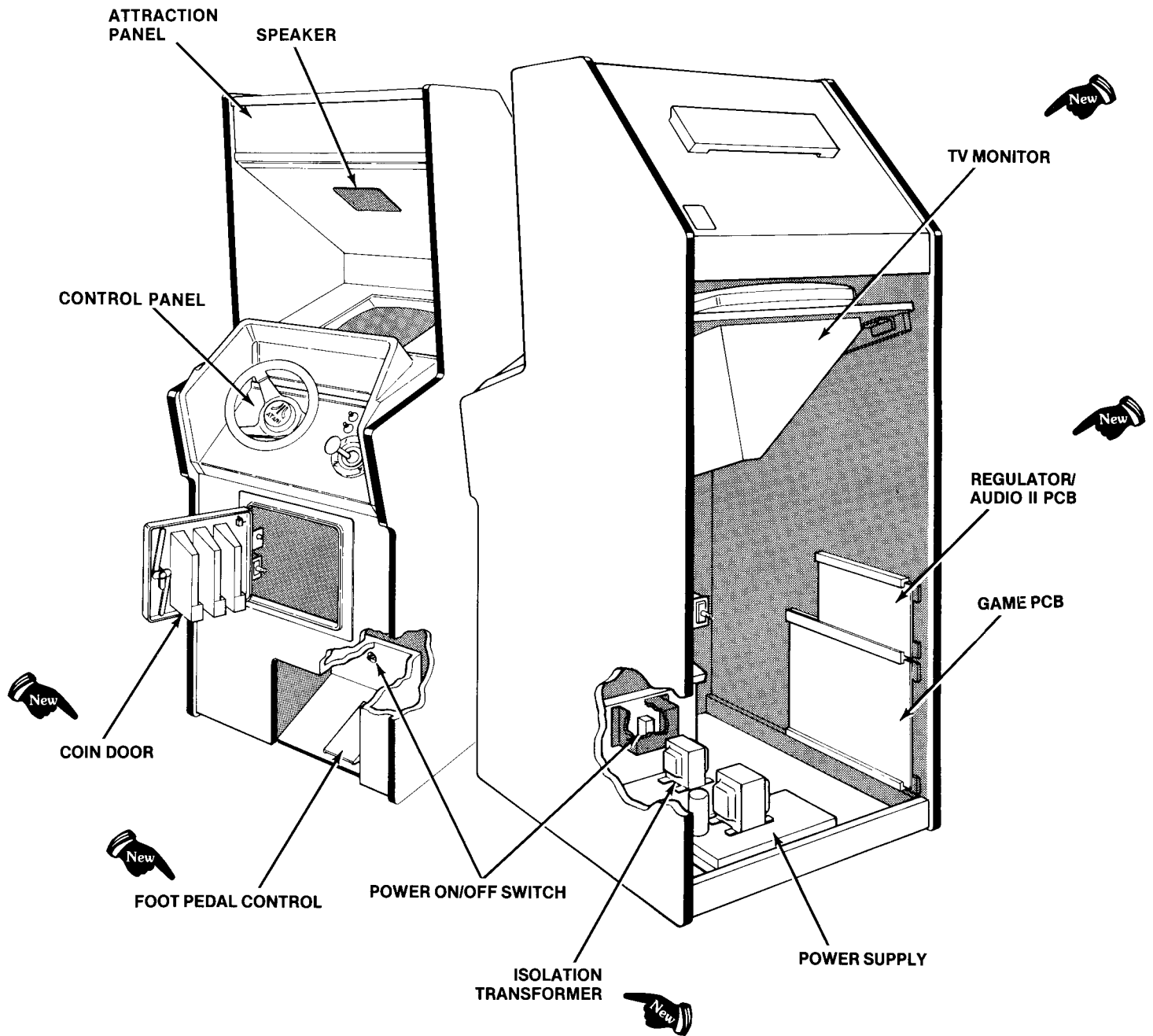


Figure 1 Overview of Game

- **Foot Pedal Assembly.** This redesigned control will universally fit Monte Carlo and all future games with foot pedal controls. It functions more smoothly and quietly because the hinge is built to tighter tolerances; the whole control is also more compact and less expensive to replace than the old style. In addition, the control's switch actuator is stronger—it is now a flat blade, not a thin wire.
- **New Coin Door.** This door will accommodate two or three mechanisms, and up to four coin counters. Its triple-arm locking bar provides added security. For greater ease of access, the self-test switch is now mounted on the door, rather than inside the cabinet. Also, for simpler maintenance the door's coin mechanisms require no adjustments.
- **Regulator/Audio II PCB.** This slightly redesigned printed-circuit board has two additional voltage regulators for games using 2708 EPROM memory chips. The board's new +12V and -5V regulators are both mounted on the heat sink. Otherwise this board is the same as past Regulator/Audio PCBs.

These new parts, as well as all other major parts in the game, are illustrated in Figure 1. Throughout this manual, wherever one of these new parts is mentioned, you will see this symbol:



## B. Game Inspection

This new game is ready to play upon removal from the shipping carton. However, your careful inspection is needed to supply the final touch of quality control. Please follow these steps to help us insure that your new game was delivered to you in good condition.

### NOTE

Do not plug the game in yet!

1. Examine the exterior of the game cabinet for dents, chips, or broken parts.
2. Unlock and open the access panel of the cabinet and inspect the interior of the game as follows:
  - Check that all plug-in connectors (on the game harness) are firmly seated. Replug any connectors found unplugged. **DON'T FORCE CONNECTORS TOGETHER.** The connectors are keyed so they only go on in the proper orientation. **A reversed edge connector will damage a PCB.**

### WARNING

To avoid possible unpleasant electrical shock, do not touch internal parts of the TV monitor with your hands or metal objects held in your hands!

- Check that all plug-in integrated circuits on the game PCB are firmly seated in their sockets.
- Note the location of the game's serial number—it is printed on the special label on the outside of the game cabinet. Verify that the serial numbers also stamped on the Game PCB, Regulator/Audio II PCB and TV Monitor are all identical. A drawing of the serial number locations is on the inside front cover of this manual. Please mention this number whenever you call your distributor for service.
- Check all major subassemblies such as the power supply, control panel and TV monitor for secure mounting. For the safety of players, be certain that all green ground wires are secured at their terminations.

## C. Game Installation

### Figure 2 Installation Requirements

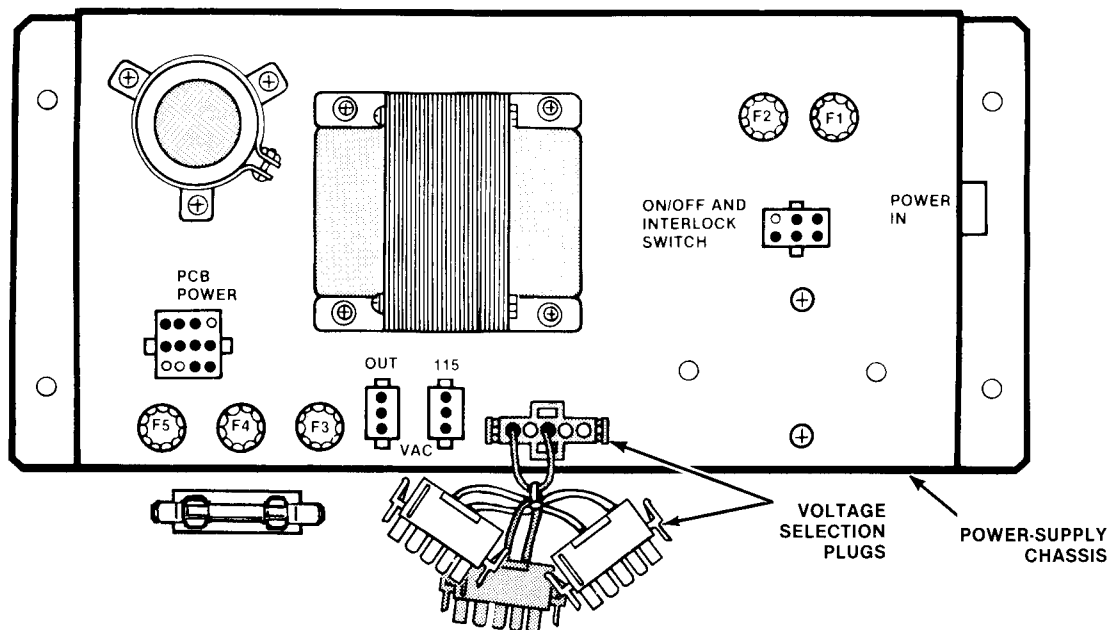
Power	125 watts
Temperature	0 to 38°C (32 to 100°F)
Humidity	Not over 95% relative
Space Required	64 × 99 cm (25¼ × 39 in.)
Game Height	179 cm (70½ in.)

### 1. Voltage Selection

Before plugging in your game, make sure that the voltage selection plug on the power supply (see Figure 3) is correct for your location's line voltage. Check the wire color on the plug and see if it is correct per the list below.

Line Voltage Range	Voltage Selection Plug Color
86-104 VAC (95)	Black
100-125 VAC (110)	Orange
190-220 VAC (205)	Green
210-240 VAC (220)	Red





**Figure 3 Power Supply**

## 2. Interlock and Power On/Off Switches

To minimize the hazard of electrical shock while working on the inside of the game cabinet, two interlock switches have been installed (see Figure 4). One is located behind the access panel and one is behind the coin door. These switches remove all AC line power from the game circuitry when a door or panel is opened. The power on/off switch is installed in a recessed area above the foot pedal.

Check for proper operation of the interlock switches by performing the following steps:

- Unlock and open the access panel and the coin door.
- Plug the AC line power cord into an AC outlet.
- Close the access panel and coin door.
- Set the power on/off switch to the on position. Within approximately 30 seconds the TV monitor should display a picture.
- Slowly open the access panel. The TV monitor picture should disappear when the panel is opened approximately 2.5 cm (1 inch). Close and lock the access panel and repeat this step with the coin door.

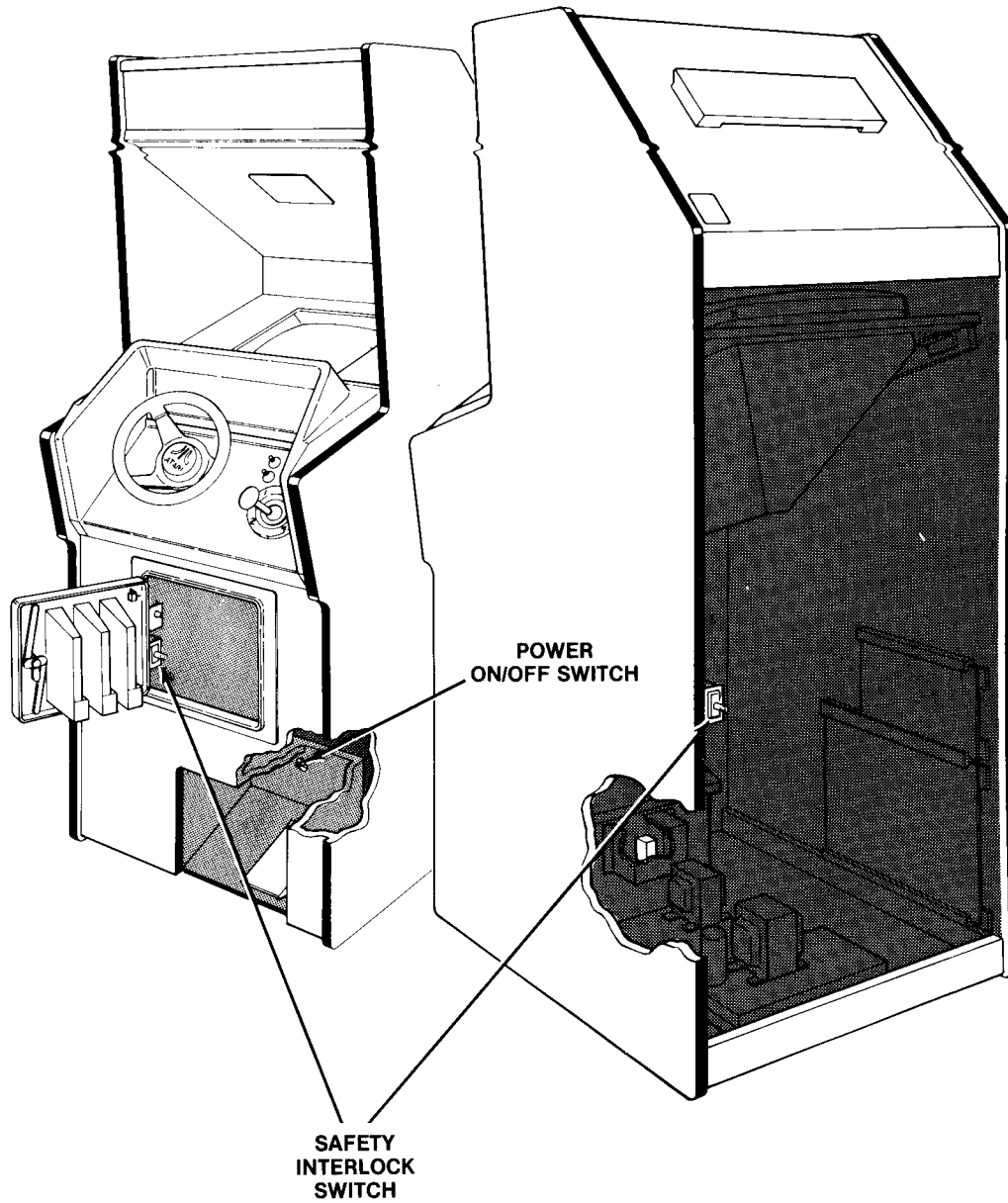
- If the results of the previous step are satisfactory, the interlock switches are operating properly. If the TV monitor doesn't go off as described, check to see if the corresponding interlock switch is broken from its mounting or stuck in the "on" position.

## D. Self-Test Procedure

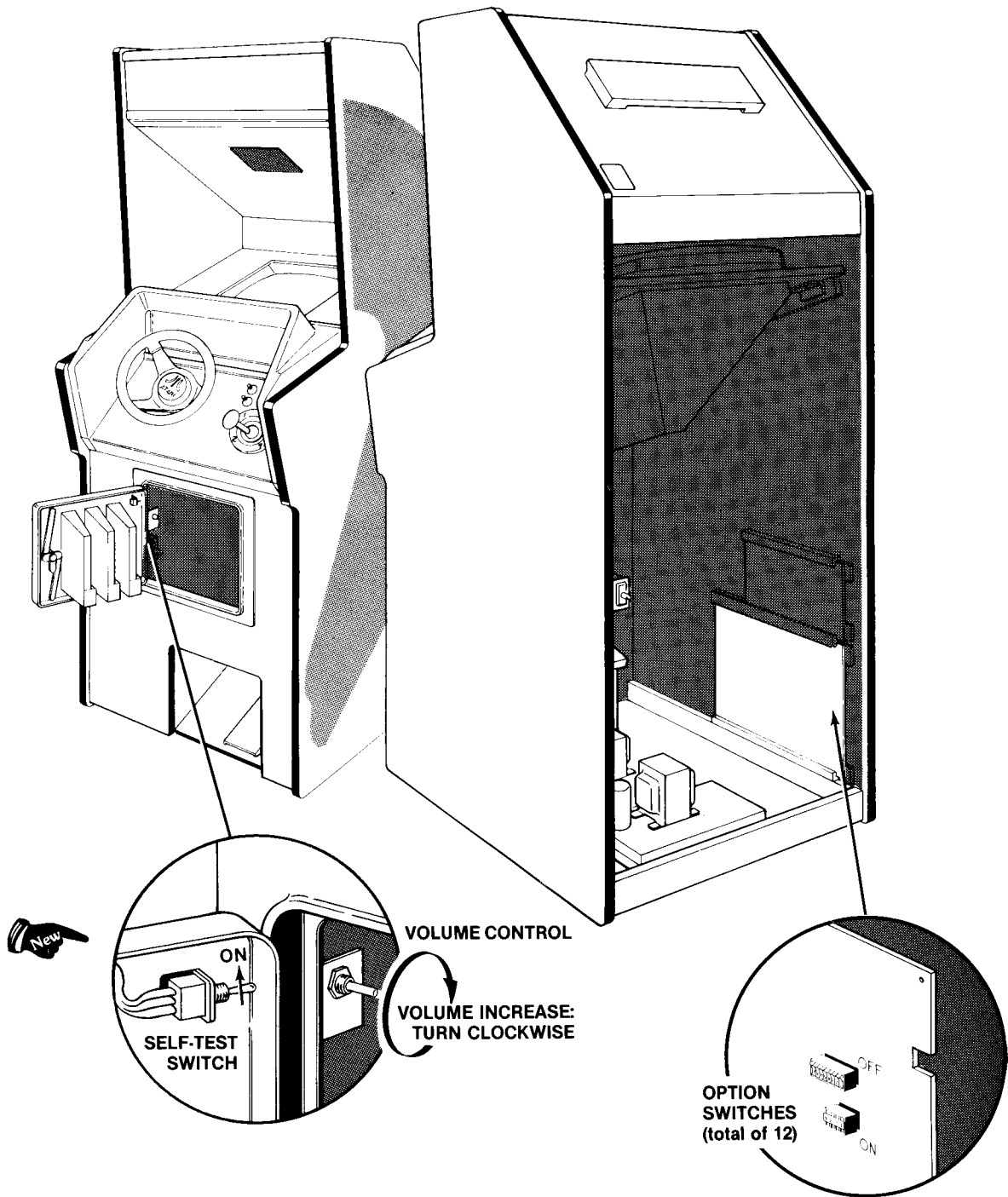
This game will test itself and provide data to demonstrate that the game's circuitry and controls are operating properly. The data is provided on the TV monitor and the game speaker; no additional equipment is necessary.

Part of the self-test procedure includes a display of the operator-selectable game options. Therefore, we suggest you run the self-test procedure anytime you need to change the game's options.

To run the self-test, follow the instructions outlined in Figure 6.

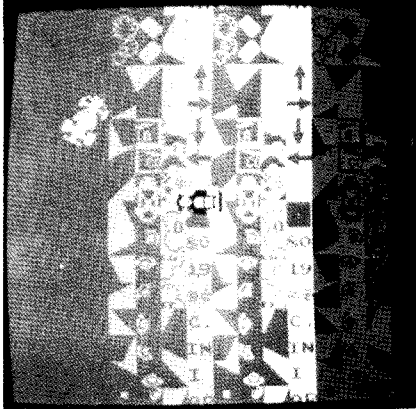


**Figure 4 Interlock and Power On/Off Switches**



**Figure 5 Location of Self-Test Switch, Volume Control and Option Switch**

**Figure 6 Self-Test Procedure**

Instruction	Result if Test Passes	Result if Test Fails
<p>1. Set self-test switch to <b>on</b> position (see Figure 5).</p>	<p>Game displays the following in the lower right corner of the TV monitor screen:</p>  <p><b>RAM 1 OK</b>                      <b>RAM 2 OK</b></p> <p><b>ROM OK</b></p>	<p><i>RAM 1 Test:</i> Screen shows “garbage” (scrolling sideways) and you hear a constantly repeated series of 8 crashes and/or skids. Crash sound(s) during any of the <b>first</b> four tones: bad RAM at L3 or its associated circuitry. Crash sound(s) during any of the <b>last</b> four tones: bad RAM at K3 or its associated circuitry. Crash sound during <b>all</b> eight tones: address line problems. Self-test will always stop here until you replace the proper RAM.</p> <p>Note: If self-test displays “garbage” (the playfield objects scroll sideways) and no series of crash and skid sounds occurs, then PROM at location J/K1 or ROM at location C1 is probably bad. These chips contain the self-test program.</p> <p><i>RAM 2 Test:</i> <b>RAM 2 OK</b> message is replaced by one of these messages:  <b>BAD RAM 2 H</b>    or  <b>BAD RAM 2 L</b>    or  <b>BAD RAM 2 HL</b></p> <p>“H” means a bad RAM at location K6. “L” means a bad RAM at L6. Both letters H &amp; L displayed means both chips are bad.</p> <p><i>ROM Test:</i> <b>ROM OK</b> message is replaced by <b>BAD ROM</b>, plus one or more of the letters <b>A</b> thru <b>H</b>. See Figure 23 for location and part number of bad ROM(s) that must be replaced.</p>
<p>2. Activate the switches in all of the following controls:</p> <ul style="list-style-type: none"> <li>• Gas pedal</li> <li>• 1st, 2nd, 3rd gears</li> <li>• Track select button</li> <li>• Start button</li> <li>• Steering wheel (left and right movement)</li> <li>• All coin trip wires</li> <li>• Slam switch</li> </ul>	<p>A very short skid sound is produced, and track select and start buttons light up in unison when each switch is opened and closed. Note: activating the coin trip wires <b>during self-test</b> will not increment the coin counters, so your accounting will still be accurate.</p>	<p>No skid sound is produced, and track select/start buttons don’t light up when control or switch is activated. This indicates a bad switch, loose harness wires or connectors, or a bad steering PCB on the steering wheel control. Note: If <b>all</b> of the switches produce no sound but light the start and track select buttons, then the speaker, its wiring, or the audio circuitry on the Regulator/Audio II or game PCB is bad. If <b>all</b> of the switches being activated cause the track select/start buttons to remain dark, then the light-emitting diodes in these buttons have burned out, or their wiring is loose.</p>
<p>3. Set the self-test switch to <b>off</b> position. For diagnostic procedures, see schematic drawings.</p>		

## Figure 7 Option Switch Settings

To change toggle positions on the switch assemblies, you need not remove the game PCB. The switches, usually colored blue, are easily accessible when the game PCB is mounted in place.

When changing the options, verify proper results on the TV monitor display during self-test. A switch toggle in the **on** position is indicated by a 1 for that switch on the TV monitor display. A

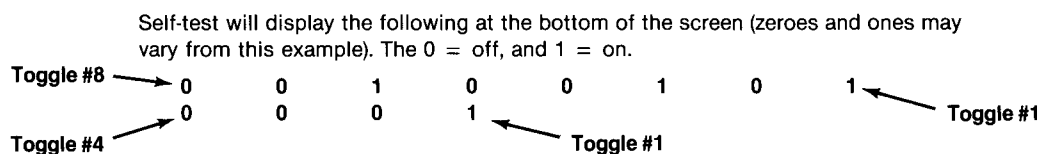
switch in the **off** position is indicated by the number 0 (see example given at bottom of this figure).

All switch settings are displayed on the monitor exactly as you view the corresponding switches on the game PCB, with toggles #1 on the right and toggles #4 and #8 on the left.

Toggle Settings of 8-Toggle Switch on Game PCB								
8	7	6	5	4	3	2	1	Option
						Off	Off	Free play
						Off	On	1 coin* for 1 play
						On	Off	1 coin* for 2 plays
						On	On	2 coins* for 1 play
								Bonus Level (bonus = 40 fuel units):
				Off	Off			No bonus
				On	Off			Liberal
				Off	On			Moderate
				On	On			Conservative
								Time (always equals 90 fuel units):
		Off	Off					1 minute per play
		On	Off					1½ minutes per play
		Off	On					2 minutes per play
		On	On					2½ minutes per play
Off	Off							English language
On	Off							French language
Off	On							Spanish language
On	On							German language

\* Note: In the U.S. and Germany only, a "coin" is defined as 25¢ or 1 DM. If your game also has \$1, 2 DM or 5 DM mechanisms, you must set the center and right coin mechanism multipliers as per your choice.

Toggle Settings of 4-Toggle Switch on Game PCB					Option
4	3	2	1		
U		Off	Off	Right coin mech × 1	
N		Off	On	Right coin mech × 4	
U		On	Off	Right coin mech × 5	
S		On	On	Right coin mech × 6	
E					
D	Off			Center coin mech × 1 (Both settings are for left	
	On			Center coin mech × 2 mech, if a 2-mech door)	



## E. Game Play

Atari's Monte Carlo™ is a one-player video game that simulates driving in a grand prix race. Various video-display phrases indicate score, time elapsed ("FUEL"), speed, and which track was selected at the beginning of the game (eight different ones ranging from easy to hard). Players drive the grand prix car thru the streets, while spectators observe from the side. Bales of hay, cola stands, trees, and bushes also line the roadway.

Four computer-controlled cars provide challenge: they pass the player's car at high speed and may cause it to skid or even crash. However, the computer cars are not infallible and may also skid or crash occasionally. Realistic engine revving, screeching tires and crash sounds accompany game play.

The Monte Carlo™ game has four possible modes of operation: Attract, Ready-to-Play, Play, and Self-Test. Self-test is a special mode for checking the game switches and computer functions. You may enter this mode at any time. When entered, all game credits are cancelled and the high score today is zeroed.

### 1. Attract Mode

The attract mode begins when power is applied to the game, after a play mode, or after self-test. This mode is continuous and is only interrupted when a game is paid for and accepted or when in self-test. In this mode, the TV monitor displays a simulated game with the computer cars zipping by and the player's car in the center of the screen. In addition, this mode shows the last player's score, the high score today for the current track being displayed, and the score required for bonus play.

### 2. Ready-to-Play Mode

This mode begins when sufficient coins have been accepted for a game. It ends when the START pushbutton is pressed. When this mode begins, the messages *SELECT TRACK* and *PUSH START* flash at the bottom of the screen. At this point the player may choose from eight tracks that vary in difficulty,

by repeatedly pushing the TRACK SELECT pushbutton (the numbers 1 thru 8 will appear in the lower right corner of the screen). The monitor pictures are otherwise the same as those shown in the attract mode.

### 3. Play Mode

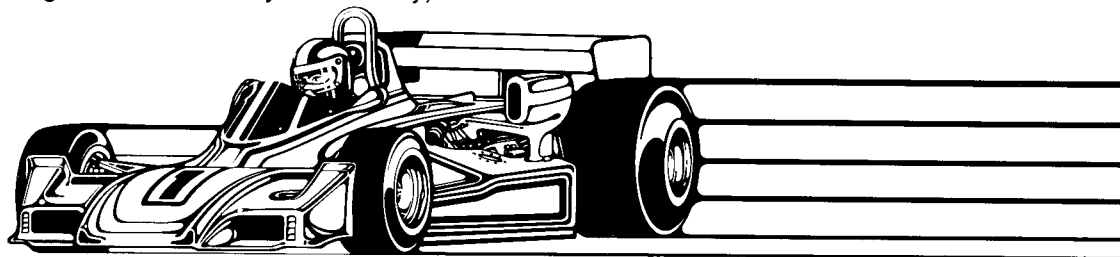
The play mode begins when the START pushbutton is pressed. The mode ends when the player's fuel has run out, including any earned for bonus play. After pressing the START button, the game will set the player's car behind the checkerboard start line, 90 fuel units are granted, and the steering wheel, gear shifter and accelerator are immediately enabled. Note that regardless of the operator option setting for game time, players will always be granted 90 fuel units, to make all Monte Carlo games appear equal in game length.

As the player rounds the turns, he or she is permitted to drive somewhat off the road without crashing. However, this will cause a screeching sound and will slow down the car. Touching an obstacle on the side, such as a tree or bale of hay, will, however, cause a crash. To continue, you must straighten out the car, shift into first gear and accelerate back onto the roadway.

Bottlenecks and hairpin curves in the road provide added challenge to the player, in addition to the computer cars that constantly pass by. Scoring is automatically calculated: each track has many invisible checkpoints that players must drive over, in order to increment their scores.

When the fuel reaches "0", the computer checks the score and compares it with the bonus level (operator-adjustable to three levels, or can be eliminated entirely). If this score has been achieved, then extra time of 40 fuel units is instantaneously awarded. All colors are reversed: the dark road turns light and the landscape turns dark. (Game play goes on continuously while all this is happening.)

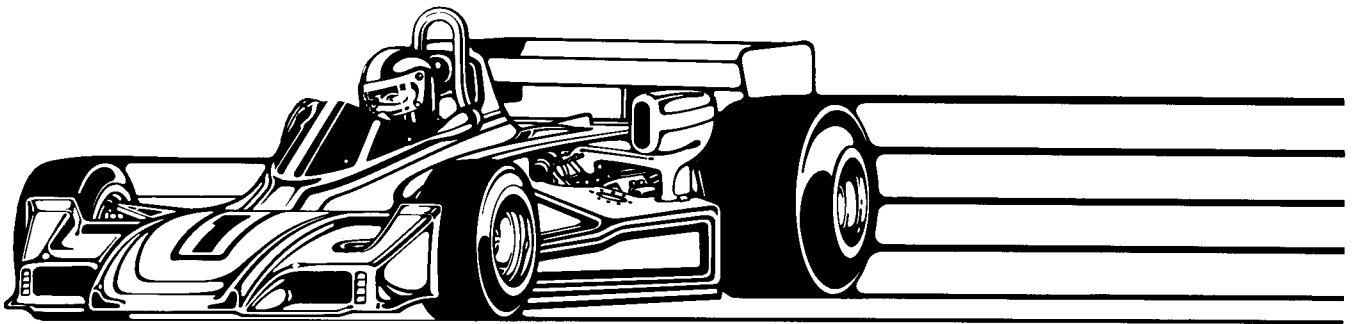
In addition, six beeps notify the player of achieving this bonus level. Only one bonus play per game is granted, i.e., another bonus cannot be earned on top of the first bonus.



All games require certain maintenance to keep them in good working order. Clean, properly maintained games will attract players and earn more profits.

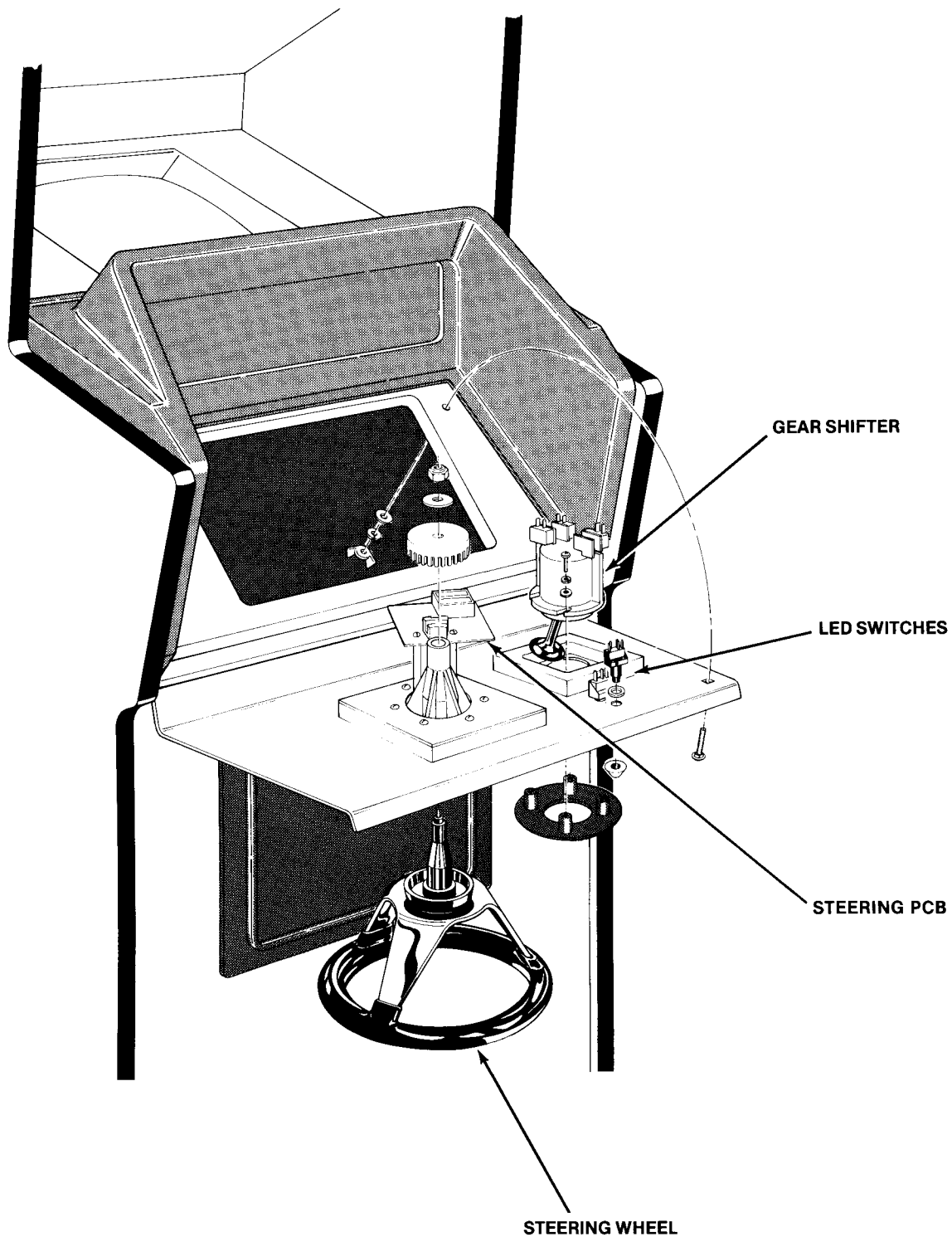
The most important maintenance item is running the self-test every time you collect money from the cash box. Just looking at a game will not tell you if the foot pedal, steering wheel or gear shifter controls, LED switches or coin door switches are broken, or if LEDs have burned out. The self-test will inform you of any of these possible problems.

Second, you should regularly clean the outside of the game and the coin mechanisms. In addition, you will need to regularly lubricate the steering wheel, foot pedal, and gear shifter—for details see this chapter.



# Maintenance and Repair





**Figure 8 Opening and Removing Parts from the Control Panel**



## A. Cleaning

The exterior of the game cabinet and the metal and acrylic surfaces may be cleaned with any non-abrasive household cleaner. If desired, special coin machine cleaners that leave no residue can be obtained from your distributor. **Do not** dry-wipe any of the acrylic panels, because any dust can scratch the surface and result in fogging the plastic.

## B. Fuse Replacement

This game contains six fuses—all on or near the power supply assembly (not including the TV monitor fuses). Replace fuses only with the same type as listed in Chapter 3 of this manual: the single fuse mounted on the floor of the cabinet and the five fuses on the power supply are all described in Figure 28. See the color TV monitor manual, TM-148, for the monitor fuse data.

## C. Opening the Control Panel

Prior to repairing or replacing any item on the control panel or prior to removing the TV monitor, unplug the game. Then open the coin door.

Reach through the opening and remove both sets of carriage bolts, wing nuts, split lock washers, and flat washers, located on the underside of the control panel (see Figure 8).

Lift up on the control panel and swing it down towards you. The three different types of controls (steering wheel, gear shifter, and LED switches) on this panel are now easily accessible for maintenance or repair. Figure 8 also provides details on how to remove the three controls.

### 1. Steering Wheel Maintenance and Repair

#### *Lubrication*

Depending on usage, your game's steering wheel will need lubrication approximately every 3 to 6 months. To do so, open the control panel as described previously. Refer to Figure 9 and unplug the harness connector on the small steering printed-circuit board (PCB). Then remove the hex nut on the end of the wheel, along with the large washer and toothed wheel.

Pull the steering wheel out of the control panel (towards the floor).

Apply a light coat of Shell Alvania #EPRO lithium-based lubricant (Atari part no. 78-1707) to the friction-producing surfaces of both white bearings—Figure 9 shows these areas in detail.

Then reassemble the steering wheel in the control panel, making sure the notches in the bearings, housing, and toothed hub all match up. **Be certain that the hub can spin freely in the slot of the optical coupler on the PCB!** Carefully plug the connector back onto the small PCB, but do not exert too much pressure, or you will break the board. Close the control panel.

#### *Repair*

Probably the only repair this control would normally require is replacement of the steering PCB. Simply remove the two small cross-recessed screws and split lock washers that mount this board onto the black housing (the toothed hub must be off first). Replace the board, mount the hub, large washer and hex nut back on the shaft, and then plug the harness connector onto the PCB.

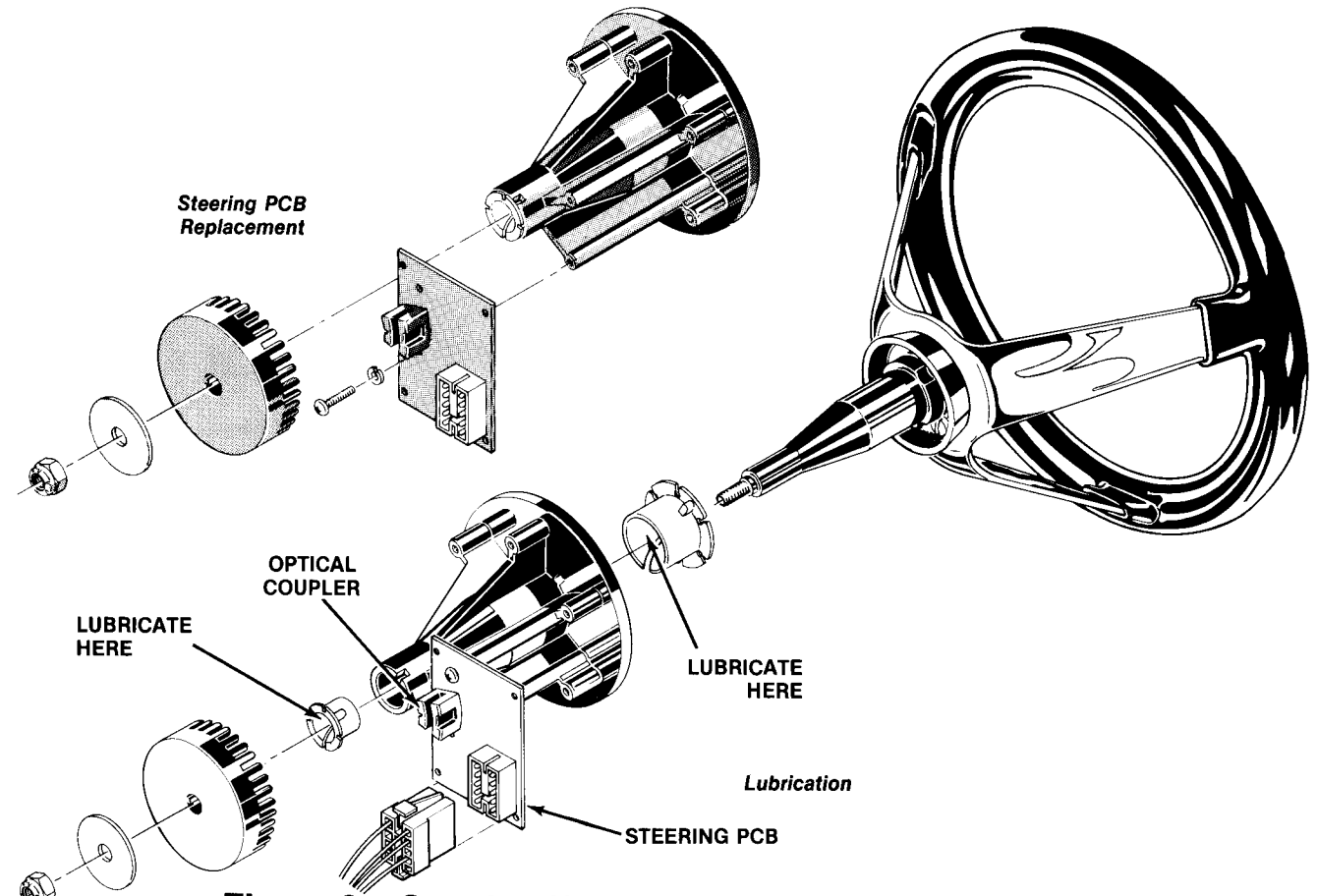
### 2. LED Switch Replacement

The light-emitting-diode (LED) switches on the control panel have a very low failure rate. In case a switch should ever be suspect, first test it per the description that follows. To replace the switch, refer to Figure 10.

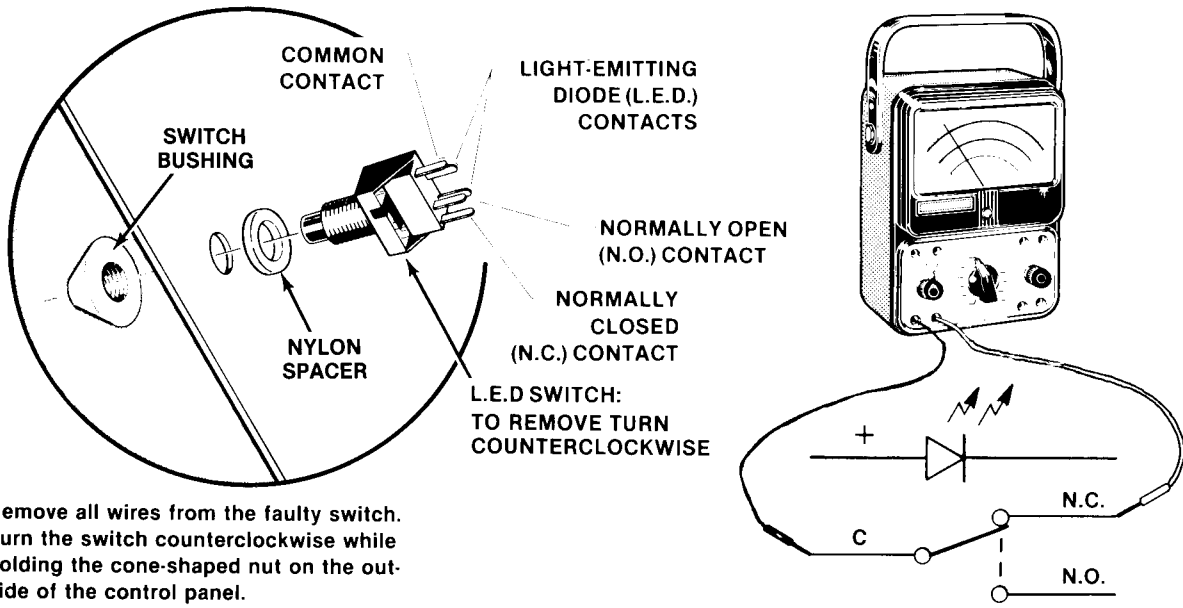
- Remove the wires from the suspected switch.
- Set multimeter to ohms scale. Set ohms scale to  $R \times 1$ , then zero the meter.
- Connect multimeter leads to appropriate LED switch contacts (see Figure 10 for designation of switch contacts and meter lead placement).
- Check contacts (push and release the switch button) for closed and open continuity.
- If the contacts do not operate sharply or always remain closed or open, then replace the LED switch as outlined in Figure 10.

### 3. Gear Shifter Maintenance and Repair

Normal maintenance involves lubricating two parts in the shifter every three to six months (this requires removing the control). First open the control panel as described previously in Figure 8. Then



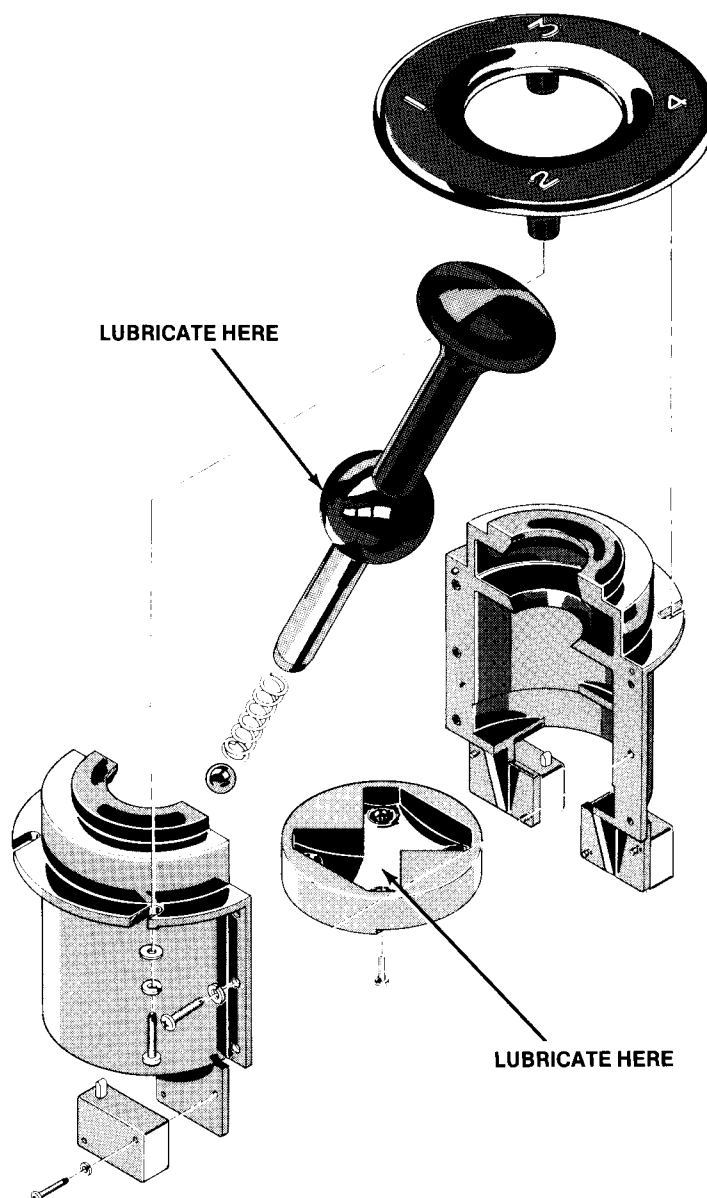
**Figure 9 Steering Wheel Maintenance and Repair**



- Remove all wires from the faulty switch.
- Turn the switch counterclockwise while holding the cone-shaped nut on the outside of the control panel.
- Install a new switch using the reverse procedure.
- Reconnect the harness wires.

**SINGLE-POLE DOUBLE-THROW (SPDT) SWITCH WITH INTERNAL LED**

**Figure 10 LED Switch Testing and Replacement**



**Figure 11 Gear Shifter Maintenance and Repair**

unplug the “quick-disconnect” connectors on the shifter’s three switches.

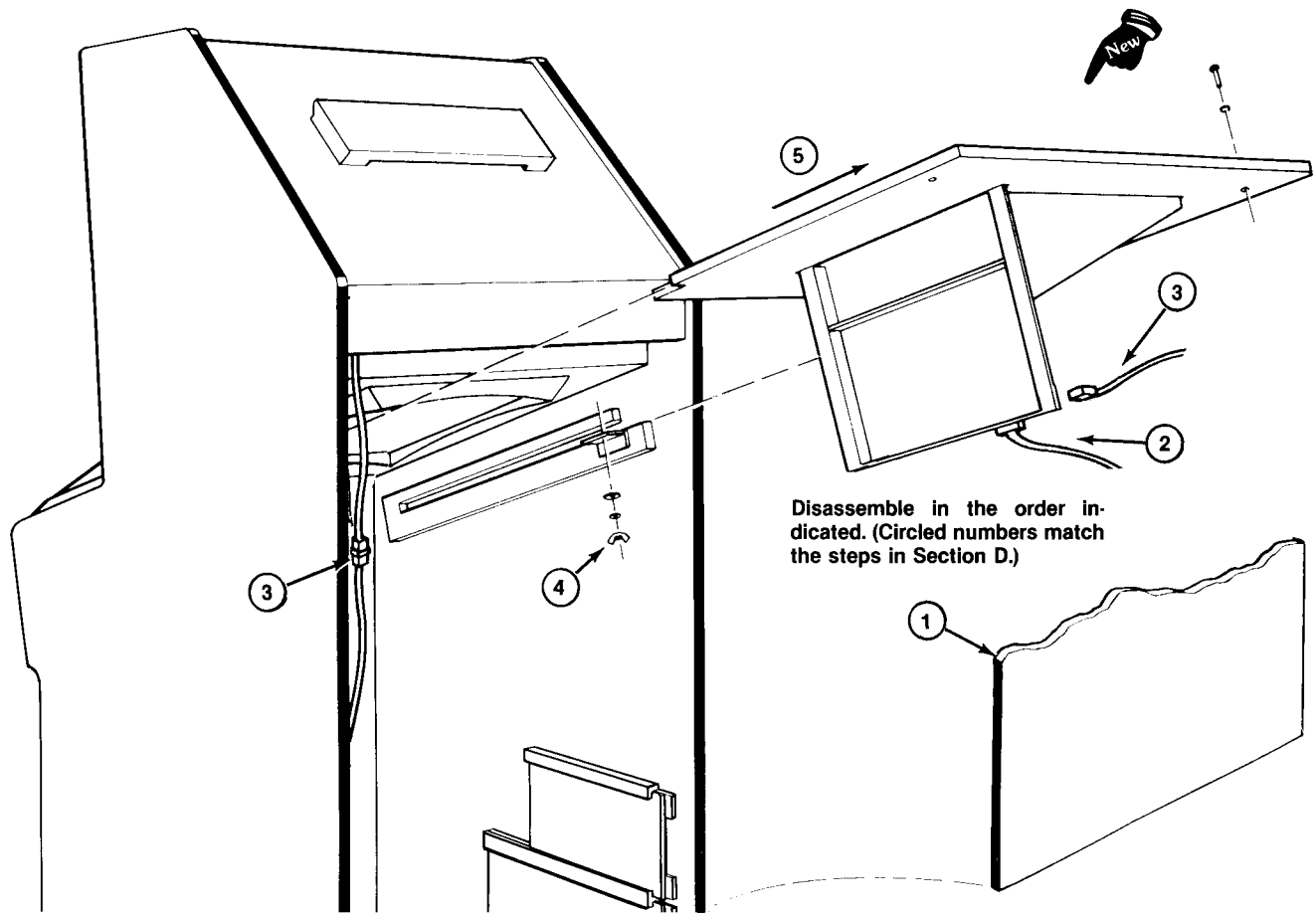
From the inside of the control panel, remove the four flat and lock washers and four screws that mount the gear shifter onto the panel and the gear-numbers bezel. Then open up the shifter assembly by removing the six split lock washers and screws (see Figure 11).

Lubricate the spherical part of the handle and the H-pattern recess of the black detent, as shown in Figure 11. Use only Dow Corning silicone compound #5 (Atari part no. 78-16002) on these surfaces.

Reassemble the gear shifter control and reinstall it in the control panel. Reconnect the harness wires as follows, making sure the right colors go to each switch:

- Black wires—one terminal on each switch (doesn’t matter which terminal)
- White/brown wire—1st gear
- White/black wire—2nd gear
- White/red wire—3rd gear

Repairs on the gear-shifter control would probably only involve replacement of switches. When removing a switch, be careful not to lose the small



Disassemble in the order indicated. (Circled numbers match the steps in Section D.)

**Figure 12 TV Monitor Removal**

rivet that sits above the white switch actuator. Note: the flat head of the rivet must always face towards the switch actuator.

## D. TV Monitor Replacement

### ⚠ WARNING ⚠

High voltages may exist in any television unit, even with power disconnected. Use extreme caution and do not touch electrical parts or the TV yoke area with your hands or with metal objects in your hands!  
If you drop the TV monitor and it breaks, it **will implode!** Shattered glass and the yoke can fly 6 feet or more from the implosion. Use care when replacing any TV monitor.

If you should need to remove the television monitor, follow steps 1 thru 4 as listed on this page. Refer to Figure 12 above.

1. Open the access panel. **Be sure the game is unplugged from its wall outlet!**
2. **If Color Monitor:** Unplug the harness connectors as follows: one is a 2-pin connector in the harness, the other is a 6-pin connector on the monitor's printed-circuit board.

### ⚠ DANGER ⚠

The color TV monitor does not contain an isolation transformer on its chassis (it is mounted instead on the floor of the cabinet). When servicing the color monitor on a test bench, **you must isolate the monitor from AC voltage with an isolation transformer.**

**If B&W Monitor:** Unplug the 12-pin harness connector on the rear of the TV monitor chassis.

3. **Be extremely careful and never touch the red anode wire or the high-voltage tube on the rear of the monitor!** Then unscrew the green ground wire that is attached to the TV monitor chassis. Also unplug the harness connector for the fluorescent light (located at the left side of the cabinet's rear opening).
4. Remove the wing nuts and washers underneath the wood television shelf. (This hardware is attached to the metal "L" brackets.)
5. Carefully slide the TV monitor chassis, still on its wood shelf, out towards the rear of the game. After replacing a monitor, be sure to run the self-test.
6. **To Change from Color to B&W Monitor:** Buy the larger cardboard bezel and install it. Buy the black-and-white TV assembly and install it; plug other 12-pin connector into its chassis. Reattach ground wire. Remove isolation transformer; buy shorting plug and install it where transformer connector used to be. (B&W monitor will not work if you leave transformer connected.)
7. **To Change from B&W to Color Monitor:** Buy the smaller cardboard bezel and install it. Buy the

color TV assembly and install it; plug the other 2-pin and 6-pin connectors into it. Reattach ground wire. Remove the small monitor shorting plug. Buy the isolation transformer and install it; plug its harness connectors together. **The isolation transformer is mandatory with the color TV—for your own safety and for the safety of all players.**

## E. Printed Circuit Board Replacement

You may wish to remove the game printed circuit board (PCB) or the Regulator/Audio II PCB for service or inspection. To do this, refer to Figure 13 and proceed as follows:

1. Open the access panel.
2. Locate the securing screw and fiber washer that hold down the PCB in its slots, and remove them.
3. If you are removing the game PCB, first remove the two tie wraps that fasten the edge connector to the game PCB. Then unplug the edge con-

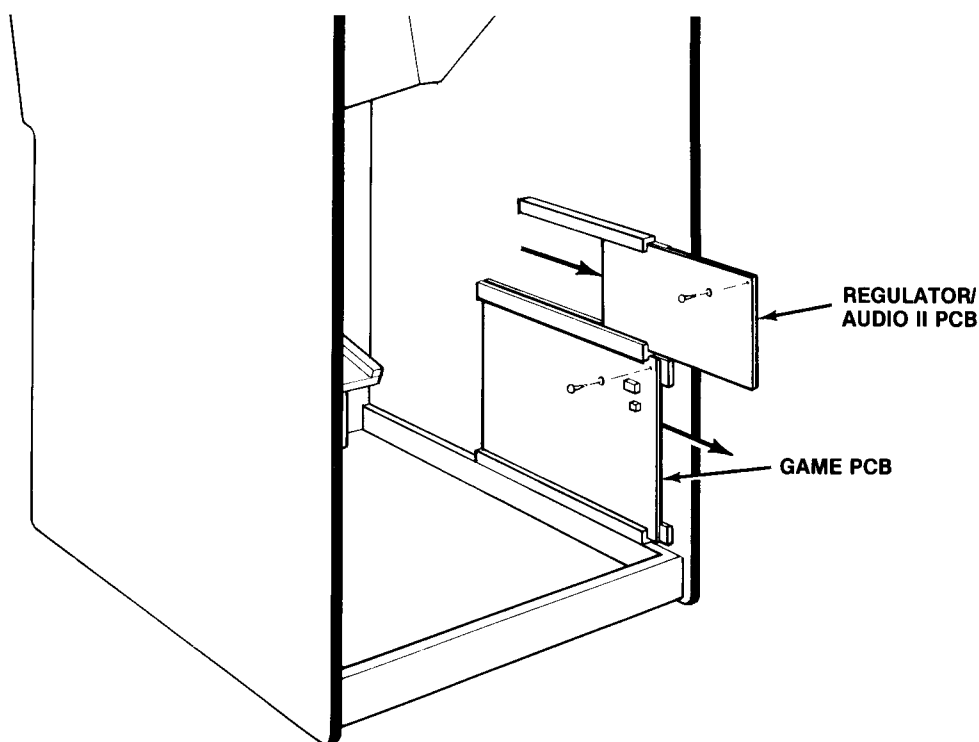


Figure 13 PCB Replacement

necter from the game PCB. If you are removing the Regulator/Audio II PCB, simply disconnect the five small harness connectors on this board.

4. Carefully slide either PCB straight out of its slots. Be careful not to twist the board, as this may loosen connections or components. Replace or repair as required.
5. Reinstall the PCB, making sure that the connectors are properly plugged in. Note that they are keyed to fit on only one way, so if they don't slip on easily, don't force them! **A reversed connector will probably damage your game and will void the warranty.**
6. Replace the securing screws and fiber washers in the PCB. If reinstalling the game PCB, secure the edge connectors with tie wraps. Close and lock the rear access panel.
7. Check that the operation of the game is correct **by performing the self-test.** This is especially important with any game when you replace a PCB. Normally the **only** adjustments on the Monte Carlo™ game are option switch changes (made on the 4- and 8-toggle DIP switches). Unless you are a qualified technician, **do not attempt to turn the small knob on the Regulator/Audio II PCB.** For information pertaining to

these controls, refer to the schematic drawings DP-149-01 and -02.

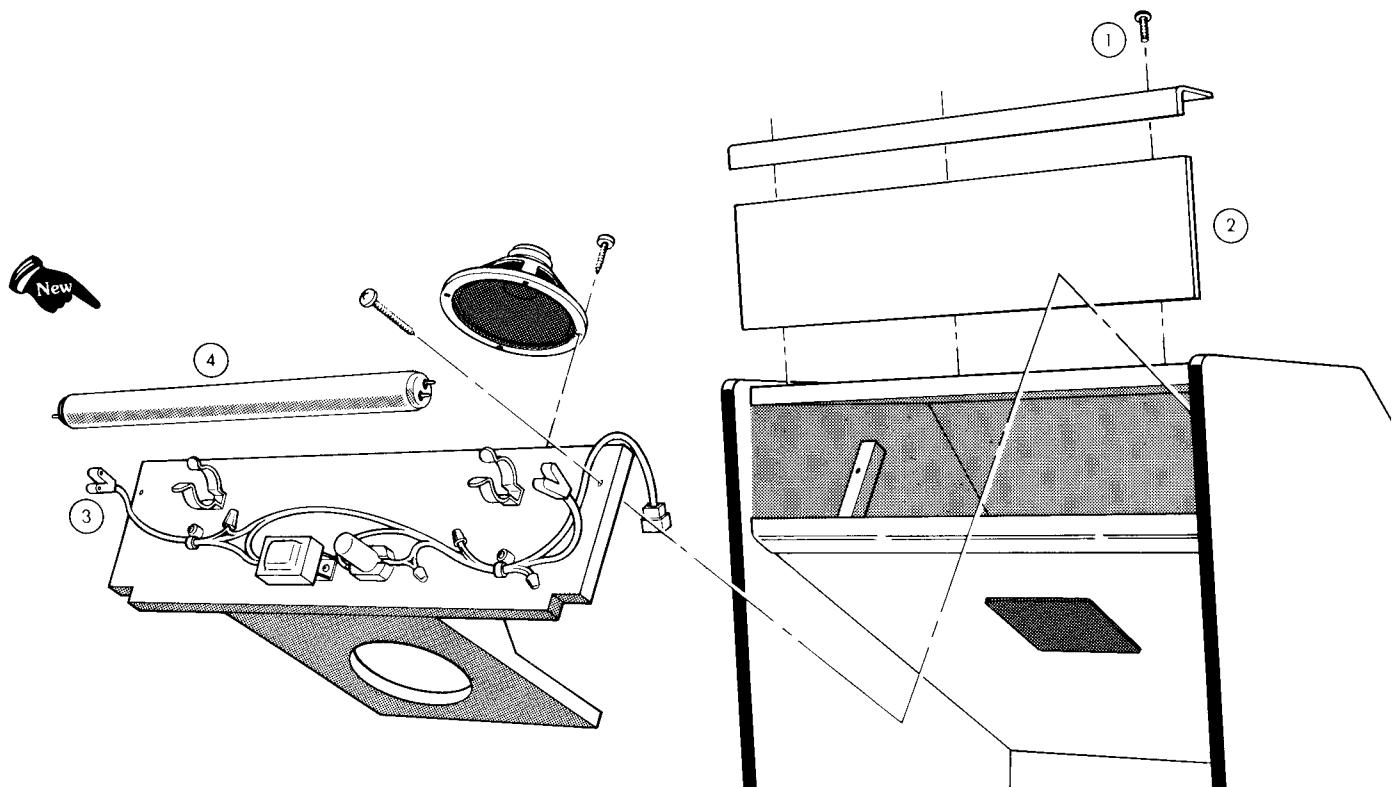
## F. Fluorescent Tube Replacement

**⚠ WARNING ⚠**

If you drop a fluorescent tube and it breaks, **it will implode!** Shattered glass can fly 6 feet or more from the implosion. Use care when replacing any fluorescent tube.

To replace the white fluorescent tube behind the graphics attraction panel, follow this procedure (see Figure 14).

1. Remove the three Allen-head screws at the top of the game. They secure the metal retainer for the silk-screened panel. Remove the retainer completely.



**Figure 14 Fluorescent Tube Replacement**

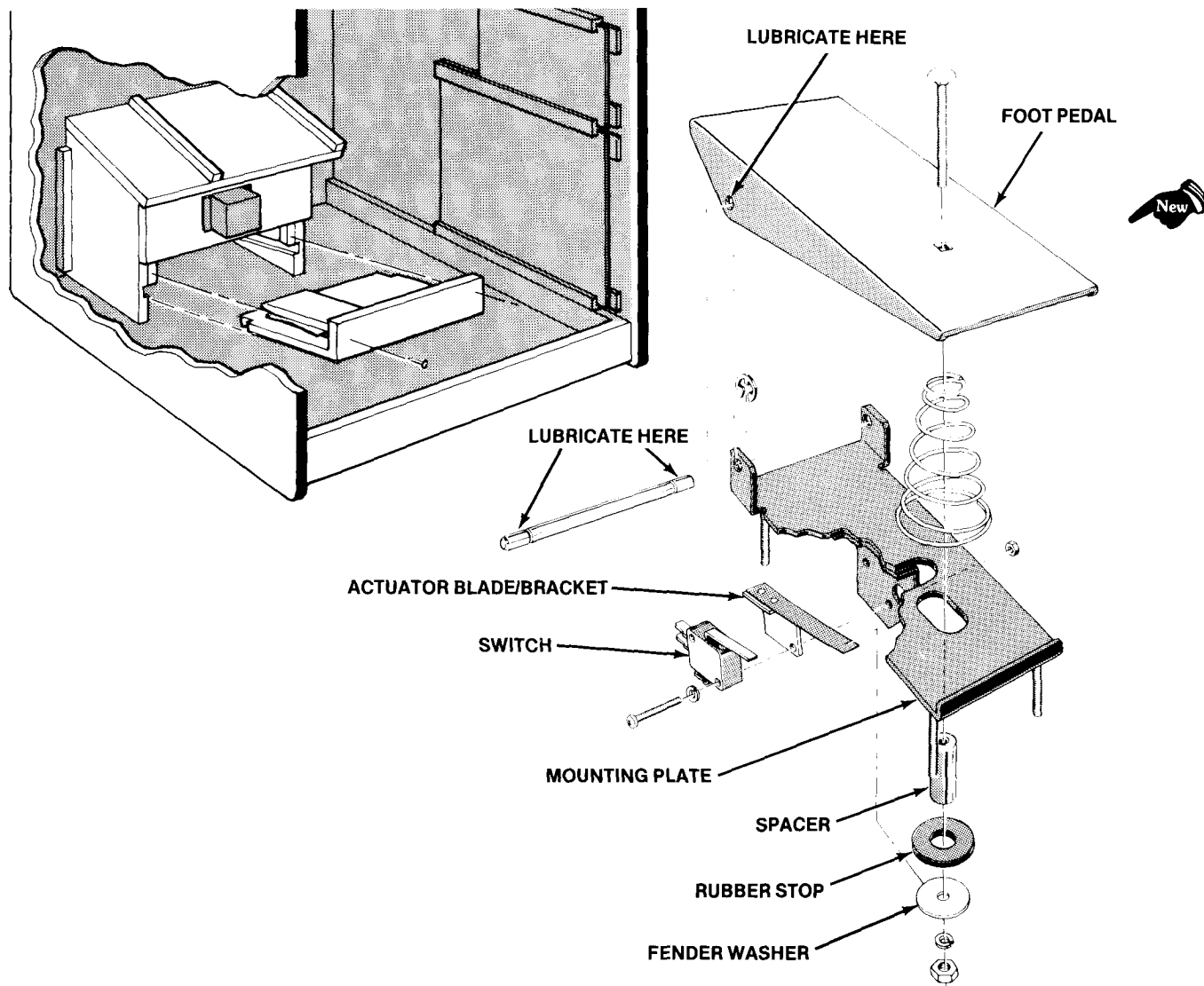


Figure 15 Foot Pedal Maintenance and Repair

2. Tilt the top of the attraction panel towards you, then lift it up and out of the bottom retainer.
3. Remove the two Y-shaped connectors from the ends of the fluorescent tube. Now carefully remove the tube from its clamps by pulling it towards you.
4. Replace with a new tube. Do not snap the tube in vigorously—you may break it, causing an implosion!
5. Close up the game by following Section F in reverse order.

## G. Foot Pedal Maintenance and Repair

The only maintenance required on this newly designed foot pedal control is lubrication. Every 3 to 6 months, or whenever the pedal becomes squeaky, you should apply a small amount of Dow Corning Molykote G-n paste to the wearing surfaces of the steel pin. Also apply this lubricant to the flat surfaces around the pin holes on the pedal.

See Figure 15 for details on how to remove the pedal from the wood enclosure and exactly where to lubricate it.

The most likely repair would be replacing the switch; perhaps the spring or the blue tempered-steel actuator may also break from abuse. Again, refer to Figure 15 for details on how to replace these items.

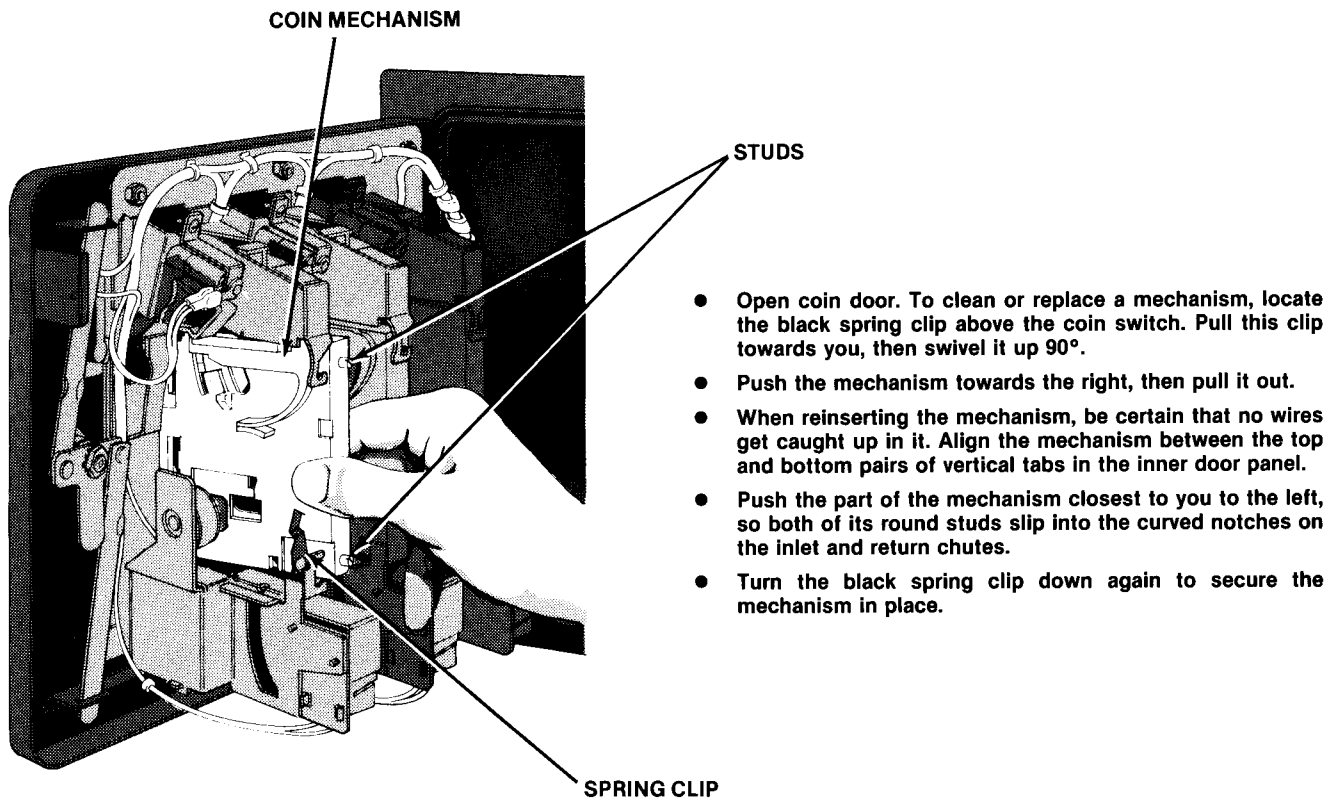


## H. Coin Door Repairs

The new Atari coin door has been totally redesigned, as described on page 3 of this manual. For

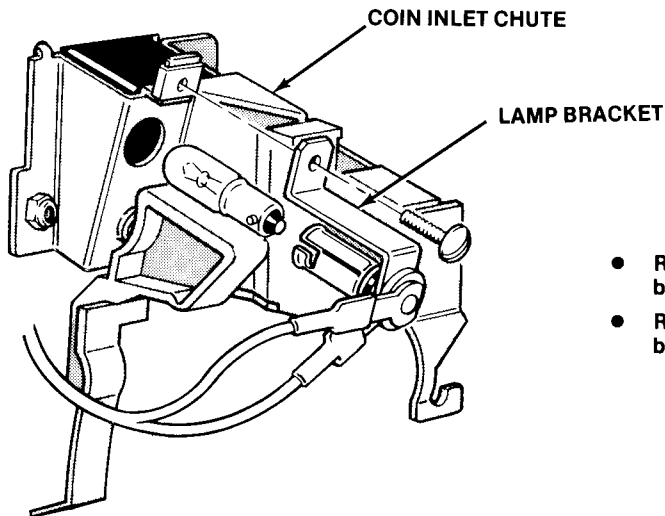
ease of maintenance, the coin door mechanisms require no adjustments. For plastic mechs, use only hot soapy water to clean them: boiling water is not needed nor even recommended, as this would soften the plastic.

To remove any mechanisms, or to replace the small lamps, switches or trip wires, follow the illustrations and instructions given in Figures 16 through 18. To obtain part numbers for ordering purposes, refer to the detailed exploded drawing of the coin door and parts list in Figure 30.



**Figure 16 Removing Coin Mechanism**





- Remove the screw that secures the lamp and its “Z” bracket to the coin inlet chute.
- Replace the burned-out bulb. Then mount the lamp holder bracket back on the coin inlet chute.

**Figure 18 Coin Door Lamp Replacement**

## I. Game Operation

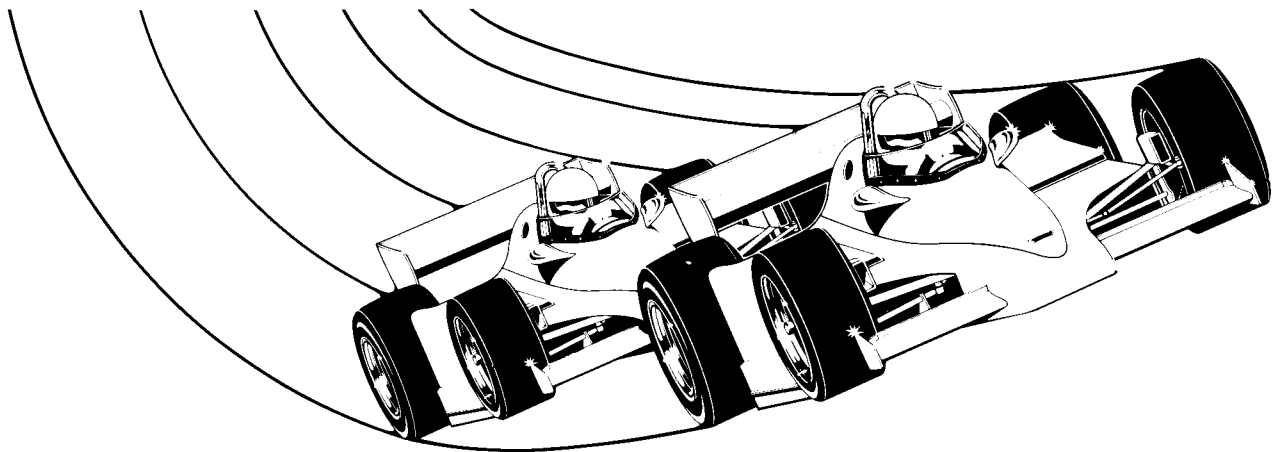
Monte Carlo™ is a microprocessor-controlled game. The microprocessor is mounted on the game PCB. The game PCB receives switch inputs from the control panel, foot pedal and coin door. These inputs are processed by the game PCB and output to the TV monitor, loudspeaker, Regulator/Audio II PCB, and control panel.

The Regulator/Audio II PCB performs two functions: first, it regulates the + 10 VDC from the power supply to + 5 VDC, the 6.3 VAC is regulated to - 5 VDC, and 25 VAC is regulated to + 12 VDC. Second, it amplifies the audio output from the game PCB. The + 5 VDC from the Regulator/Audio II PCB pro-

vides most logic power to the game PCB. The audio output from the Regulator/Audio II PCB directly drives the game speaker and is controlled by the volume control, mounted inside the coin door.

The power supply is the source of all voltages in the game. These voltages are protected by three fuses (F3, F4, and F5) on the power supply chassis. The primary winding of the power supply transformer is protected by the fuses F1 and F2 on the power supply chassis.

Figures 19A thru 19C are the wiring diagrams that show the electrical connections of the Monte Carlo game. Figures 20A thru 20D are the schematic diagrams of the Monte Carlo game.



# **WIRING AND SCHEMATIC DIAGRAMS**

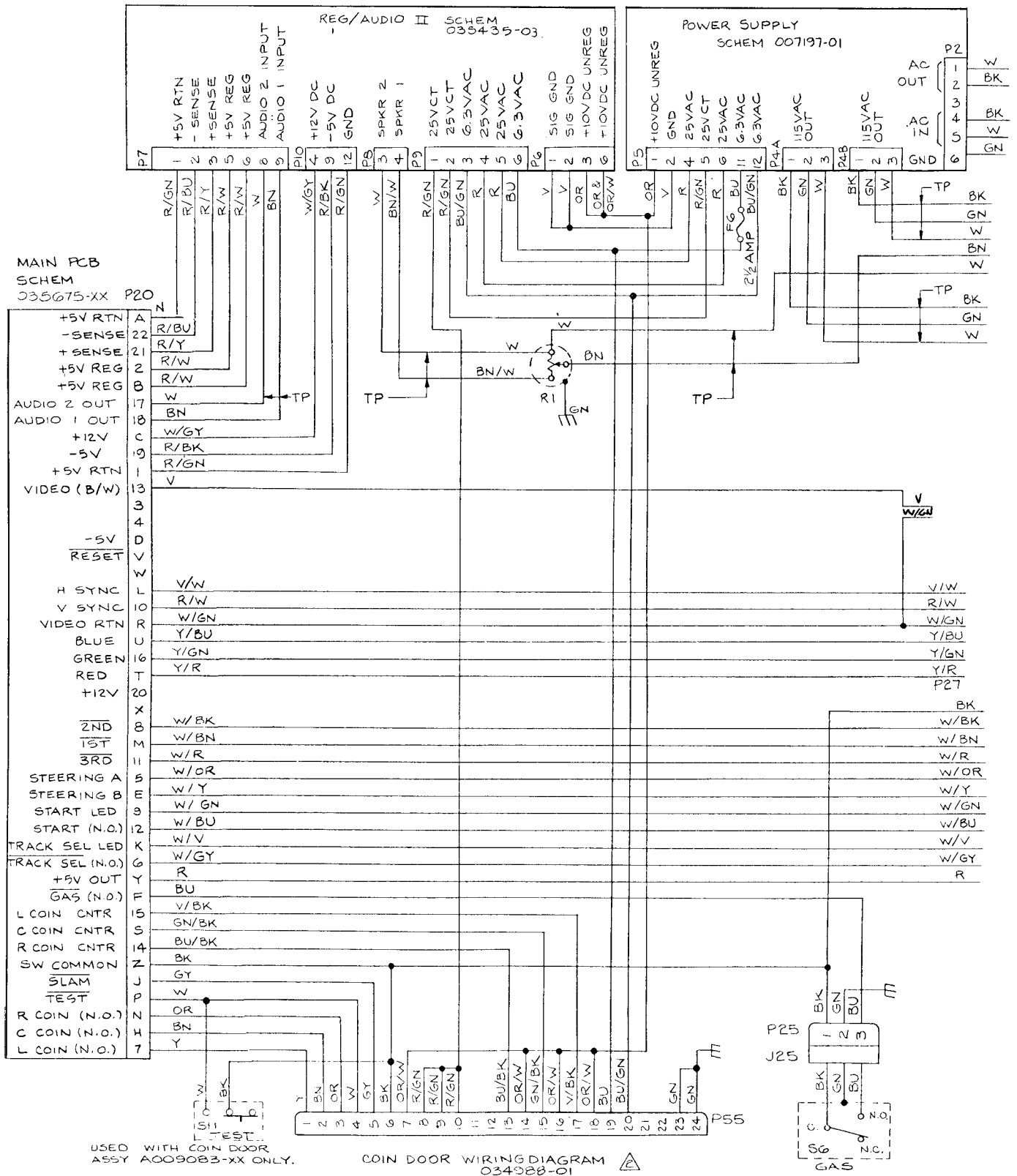
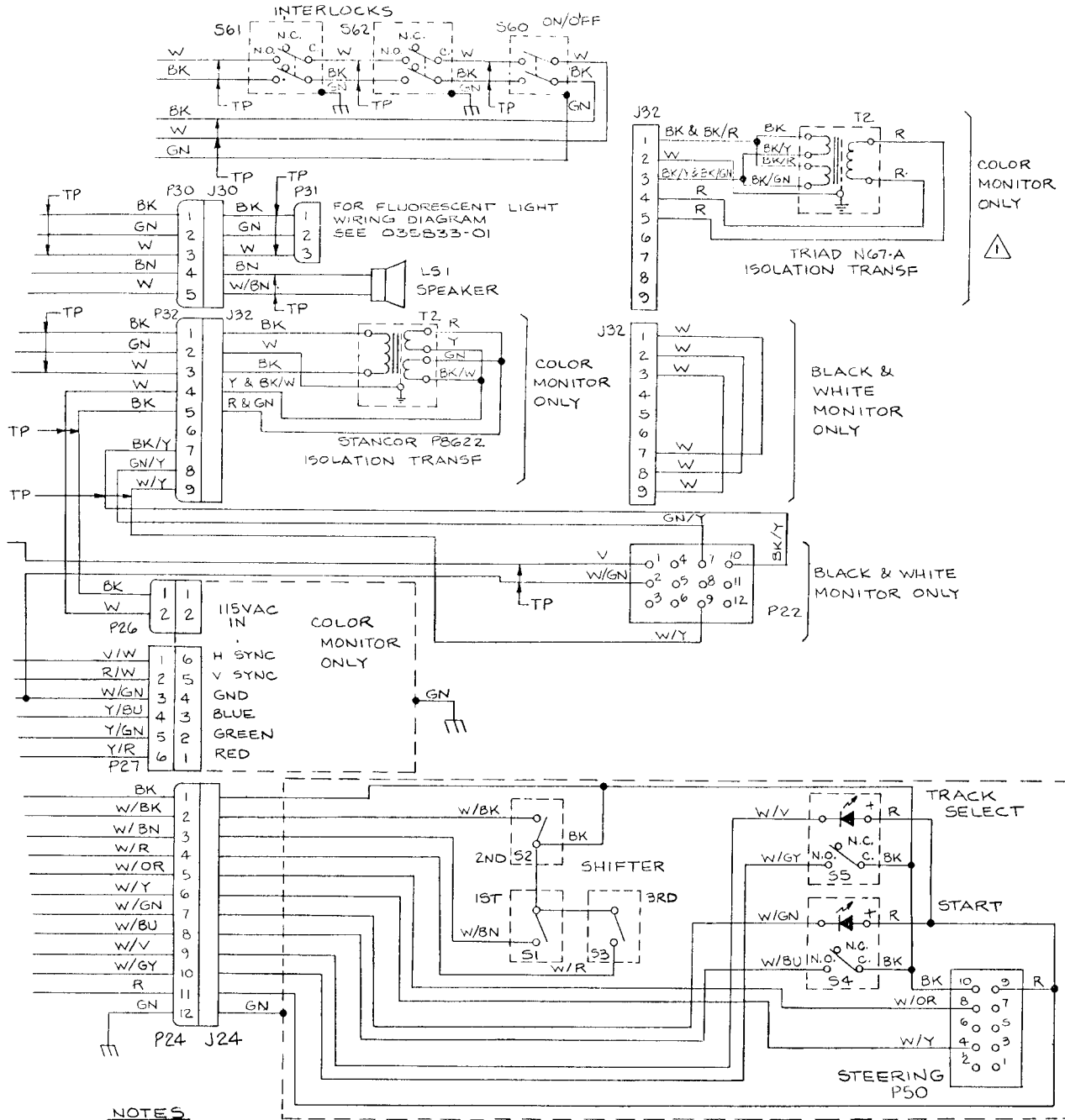


Figure 19A Monte Carlo Game Wiring Diagram



- NOTES**
- ⚠ THE TRIAD NG7-A TRANSFORMER IS AN ALTERNATE FOR THE STANCOR PB622.
  - ⚠ FOR GAMES EQUIPPED WITH A009083-XX COIN DOOR SEE COIN DOOR WIRING DIAGRAM 030401-01 AND COIN DOOR ADAPTER HARNESS ASSY/WIRING DIAGRAM A035319-01.

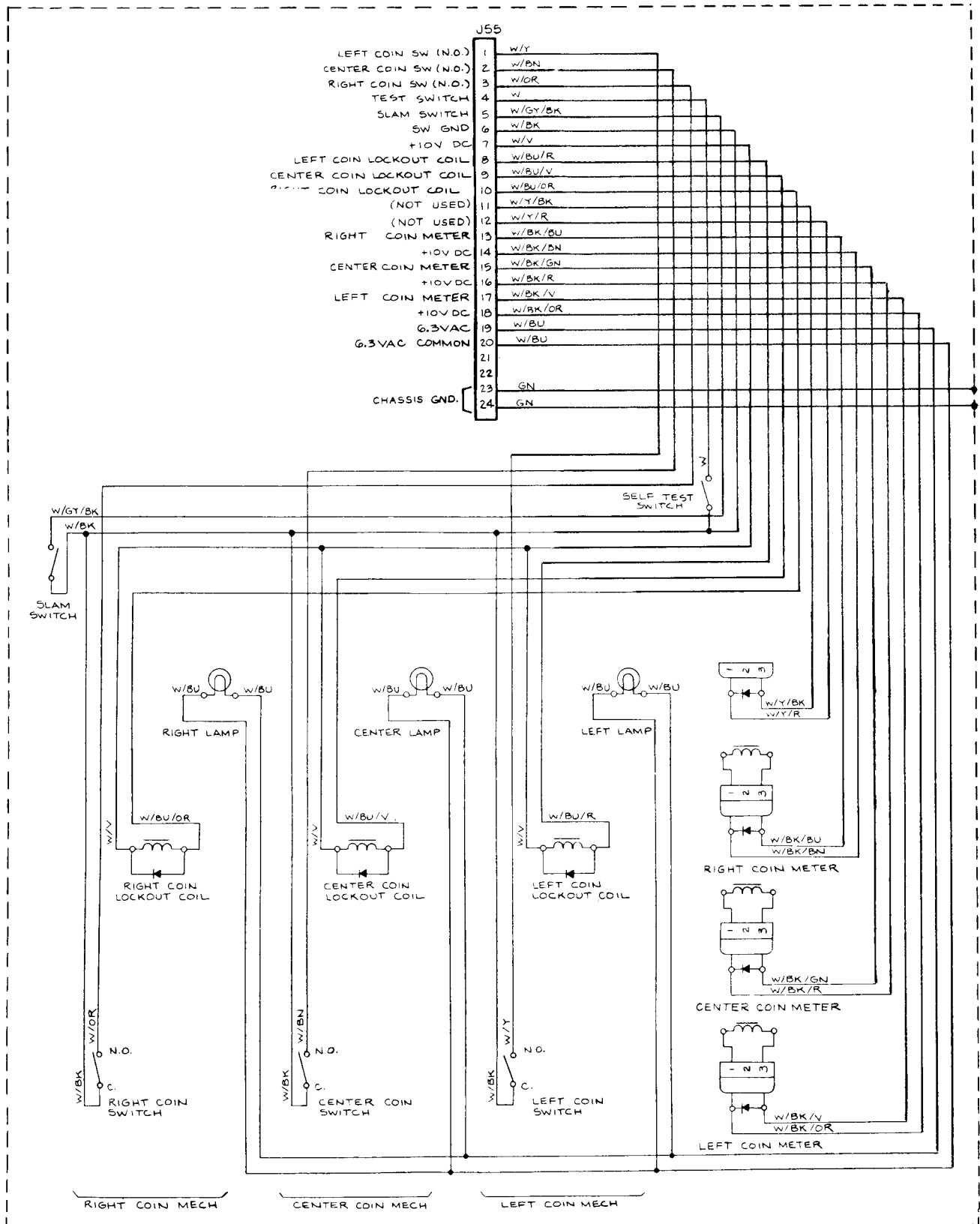
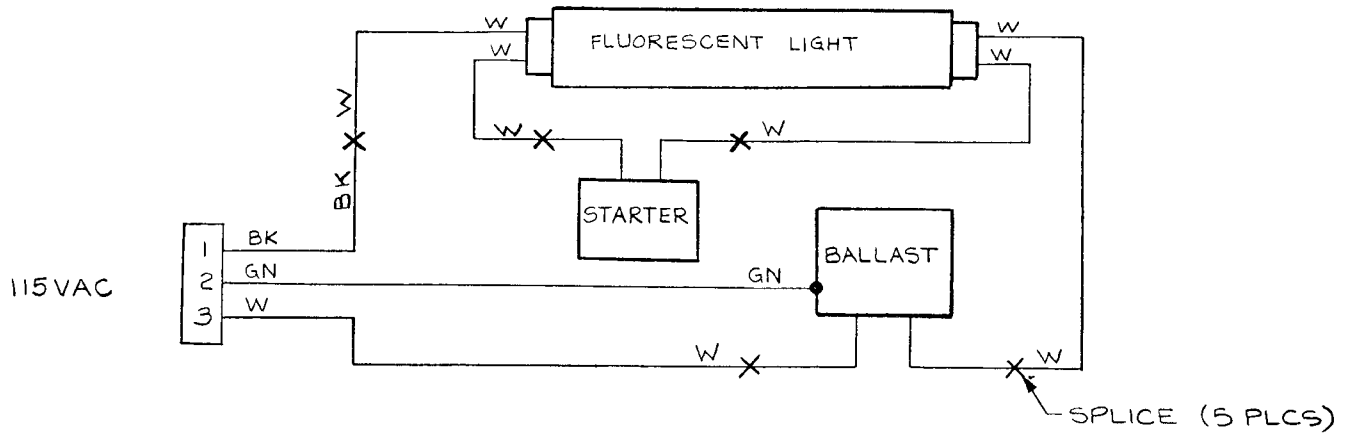
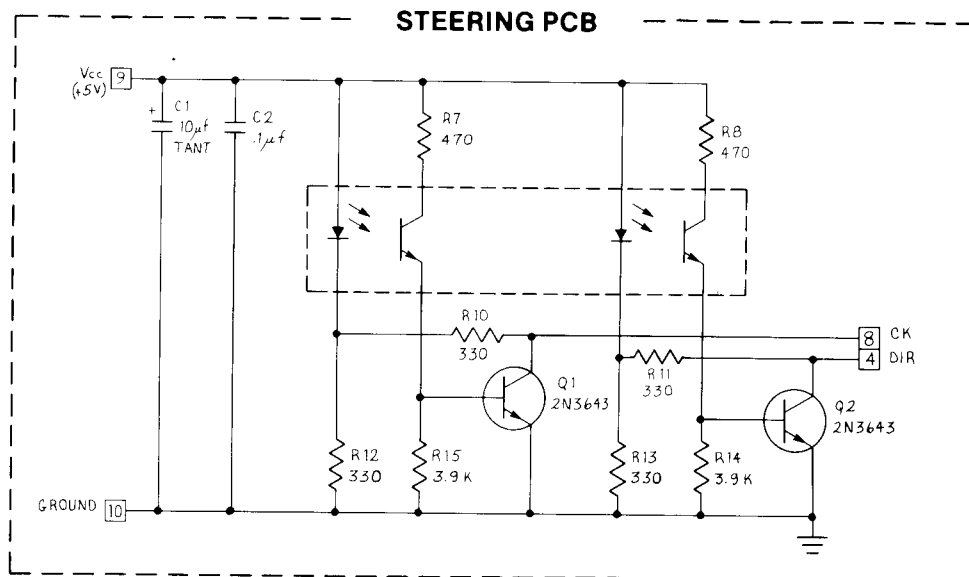


Figure 19B Coin Door Wiring Diagram



**Figure 19C Fluorescent Light Wiring Diagram**



**Figure 20A Steering PCB Schematic Diagram**

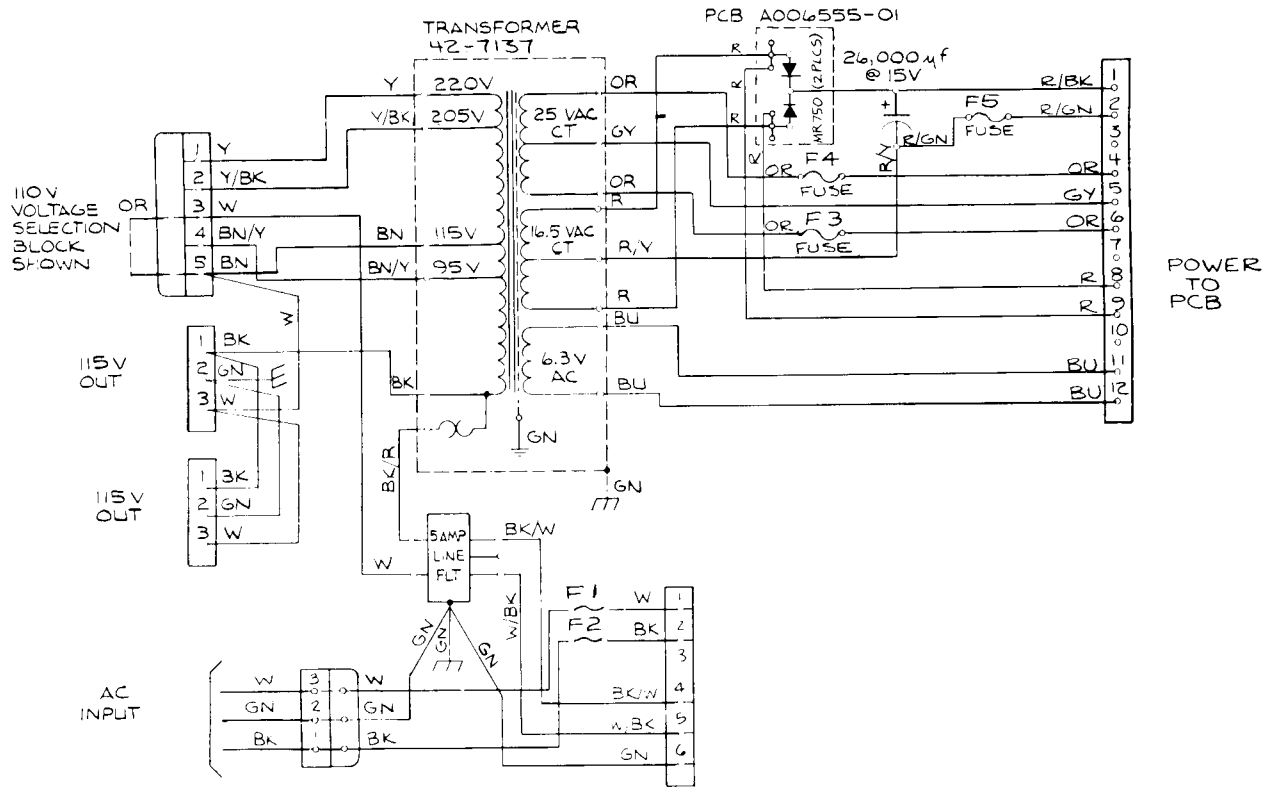


Figure 20B Power Supply Schematic Diagram

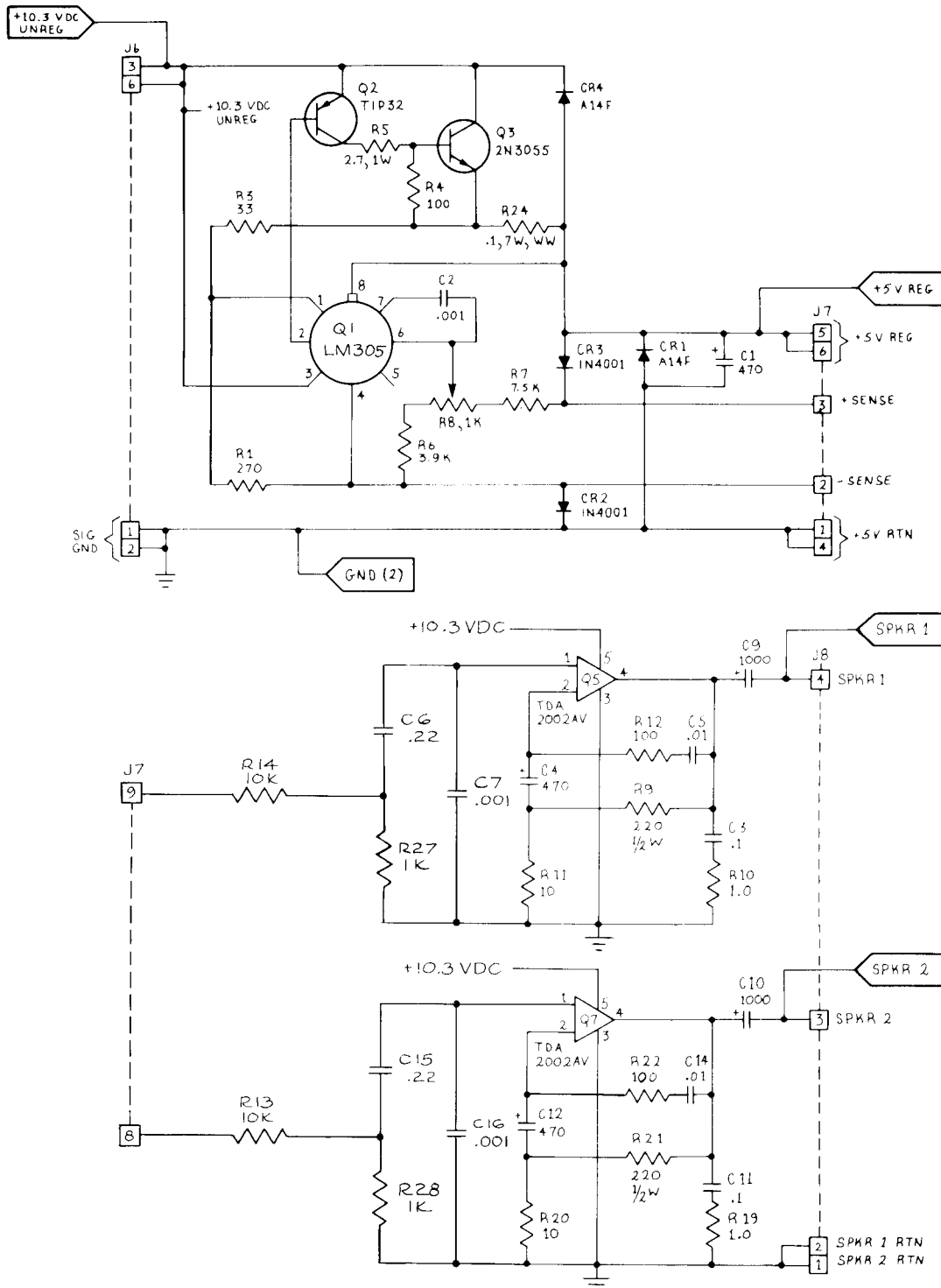


Figure 20C Regulator/Audio II PCB Schematic Diagram



## Diagnostics

The Monte Carlo™ diagnostics are a subsection of the self-test procedure. Start the series of 13 diagnostics by first entering the self-test. Then simultaneously hold slam switch on coin door closed while pressing START button. Letter **A** will appear on the screen below last digit of option switch display—meaning Test A is in progress. This letter increments with each press of START button.

To advance to next test, press START button. To freeze the screen image during any test, put the gear shifter into 1st gear (exception: image will not be frozen in Tests G and M). To unfreeze the image, shift into any other gear or “neutral.”

### Test A, Horizontal Playfield Scrolling

Playfield characters and colors are displayed scrolling smoothly.

### Test B, Vertical Playfield Scrolling

### Test C, Player Car Rotation

Car in center of screen rotates clockwise (playfield will be blanked out).

### Test D, Drone Car Vertical Scrolling

The drone or computer-controlled car will scroll across the screen.

### Test E, Drone Car Horizontal Scrolling

### Test F, Drone Car Rotation and Colors

The drone car rotates clockwise and jumps to all 4 corners of the screen while rotating. After each complete revolution, its color will change (4 colors in all).

### Test G, Video Invert and Beeper Sound

The solid background will alternate between normal and a lighter value of grey or a lighter color. The beeper sound will go on and off.

### Test H, Player Car Motor Frequency

This sound will start at a high frequency or pitch and gradually go to a low frequency, then repeat. (You will also hear the player car sound in Tests I, J, K, and L.)

### Test I, Drone Car Motor Frequency

### Test J, Drone Car Motor Loudness

This sound will start at a high volume and gradually go to silence, then repeat. *Do not adjust the volume control during this test.*

### Test K, Skid Sound

### Test L, Crash Sound

### Test M, Convergence Pattern

The convergence pattern is used to adjust color convergence on games with color monitors. For instructions on how to converge your monitor, refer to the service manual for this color TV, TM-148. *Do not attempt to perform any color TV adjustments unless you are a qualified technician!*

Push the START switch one more time to return game to self-test. Then set self-test switch to “off” to return to the attract mode.

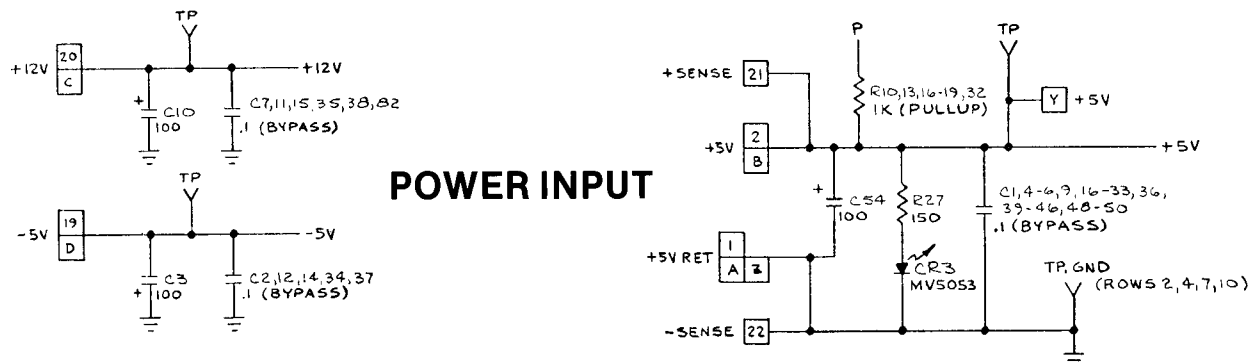
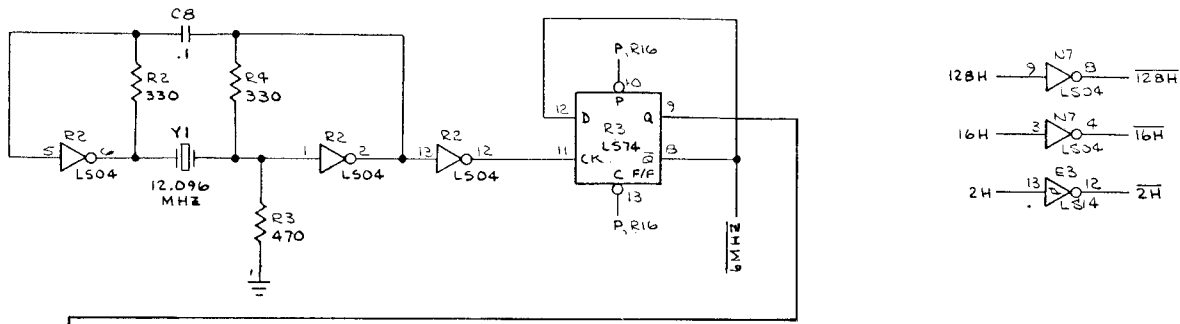
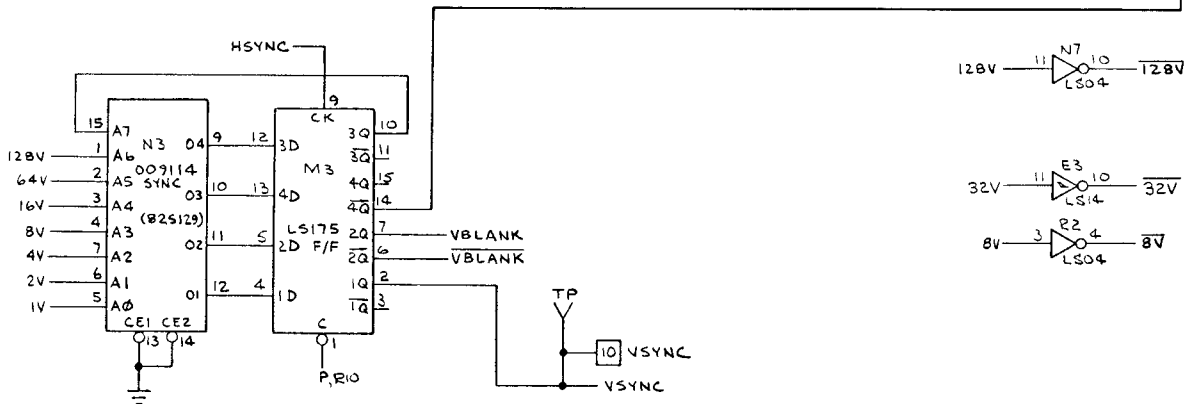
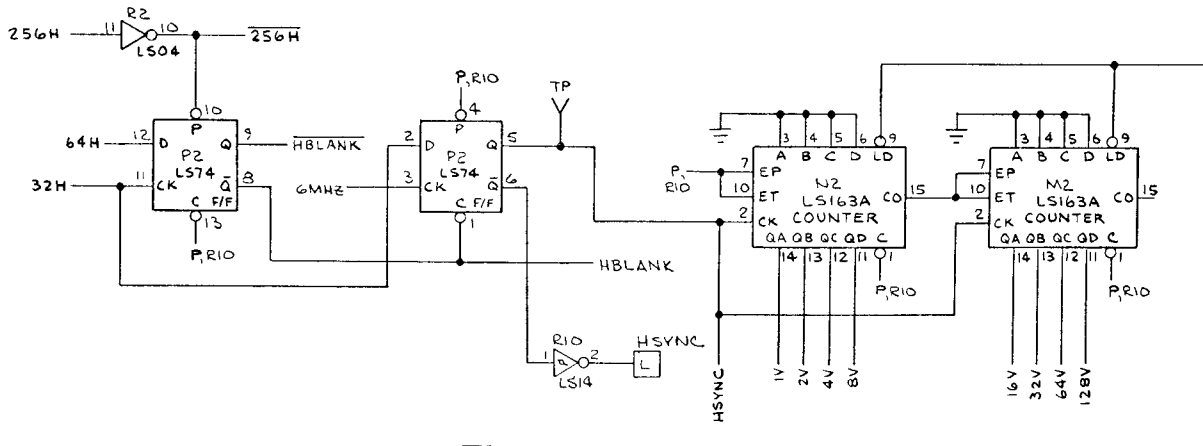
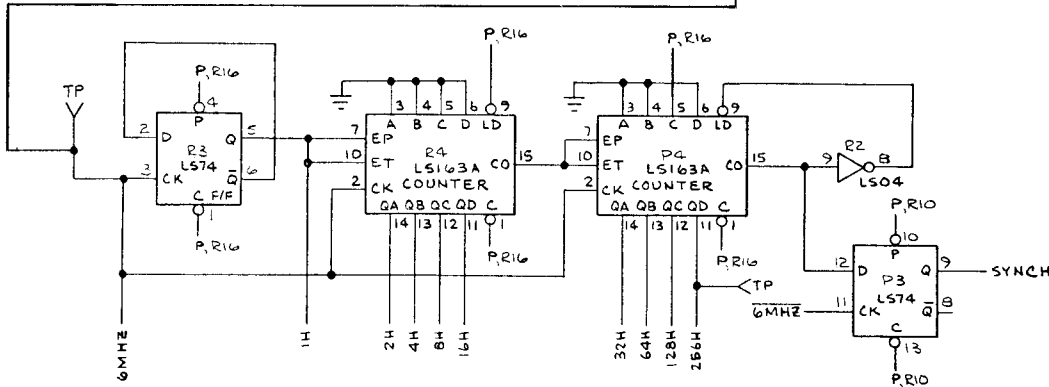


Figure 20D Game PCB Schematic Diagram



**SYNC**



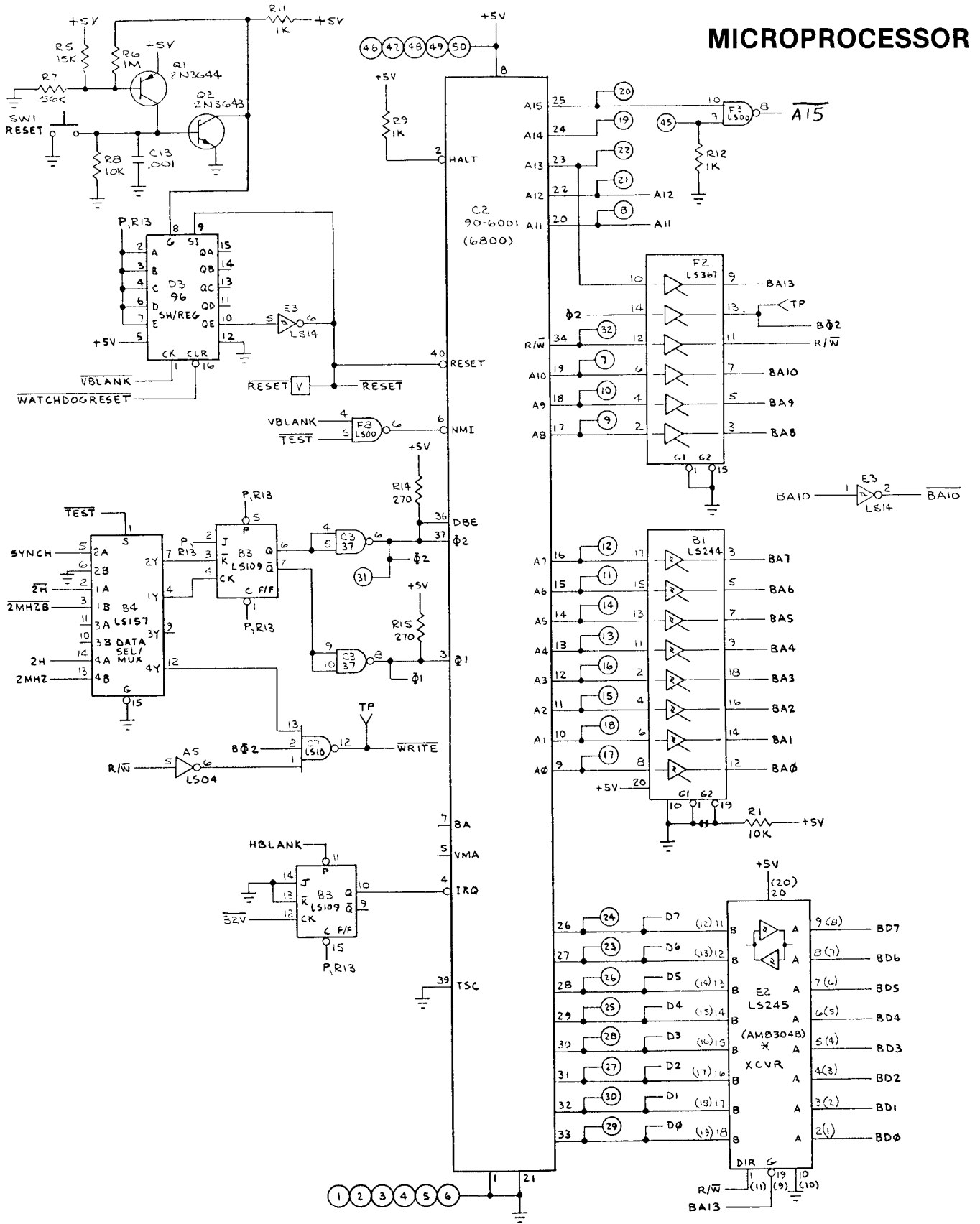
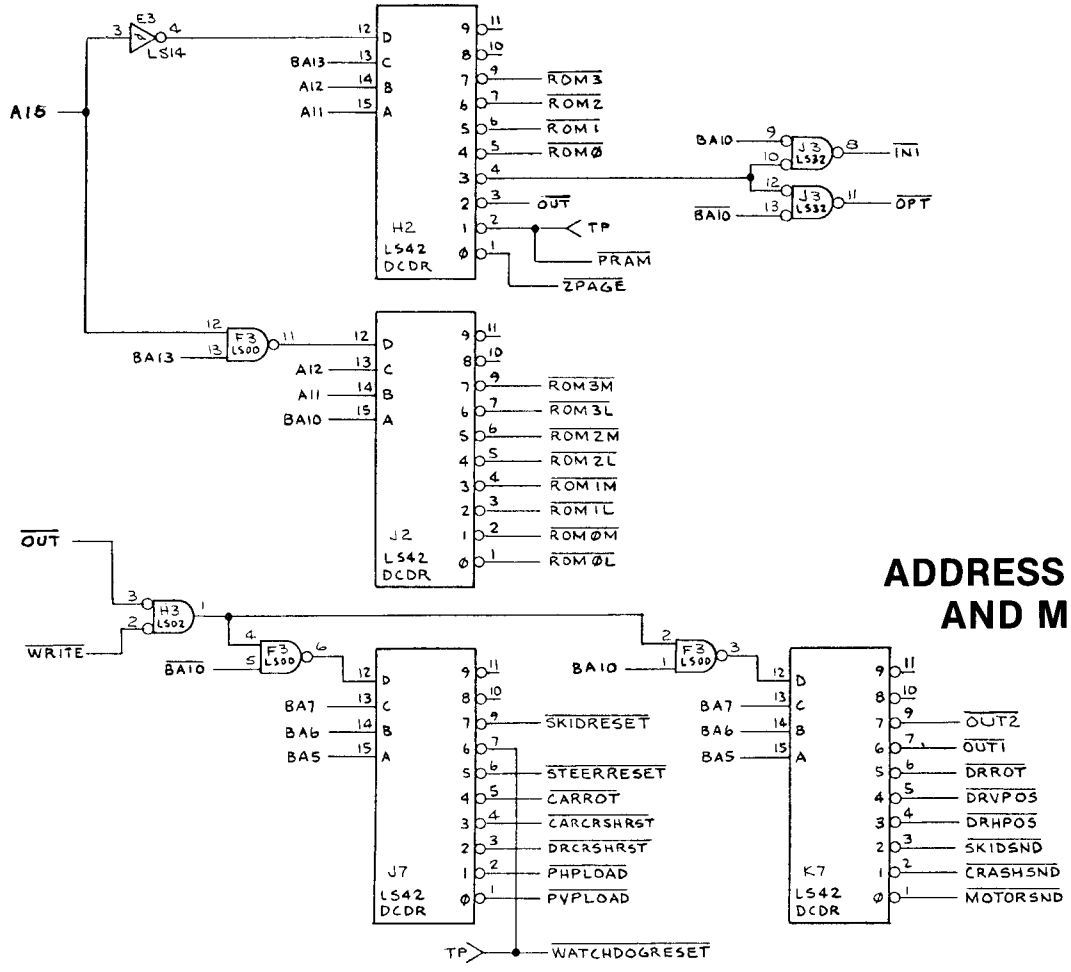


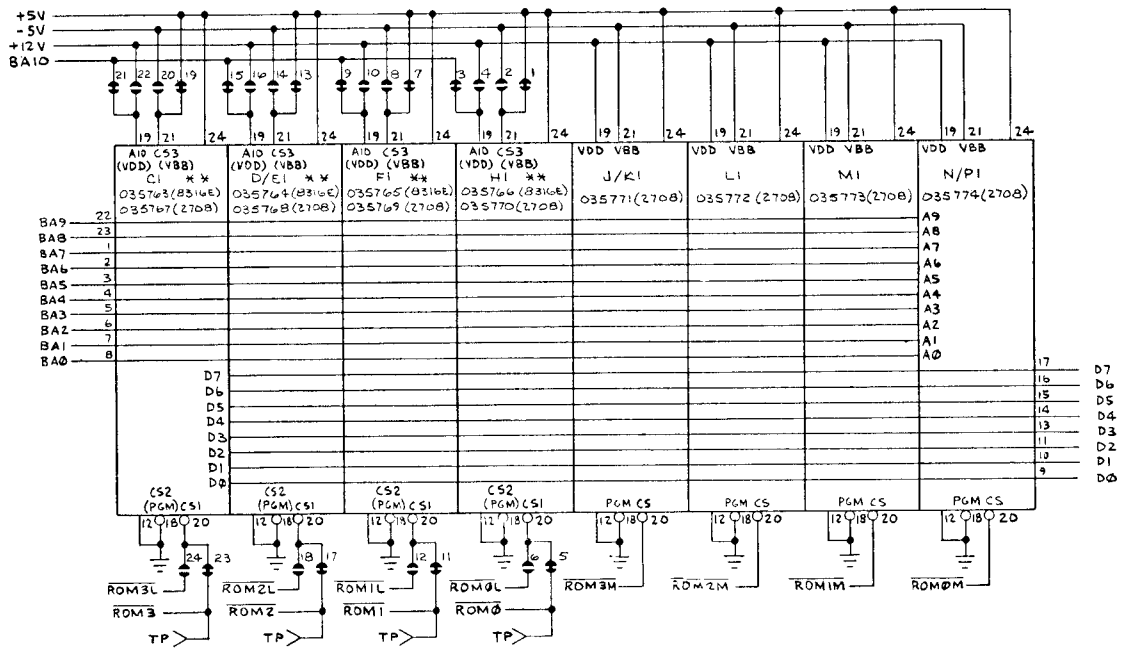
Figure 20D Game PCB Schematic (Continued)

# MEMORY MAP

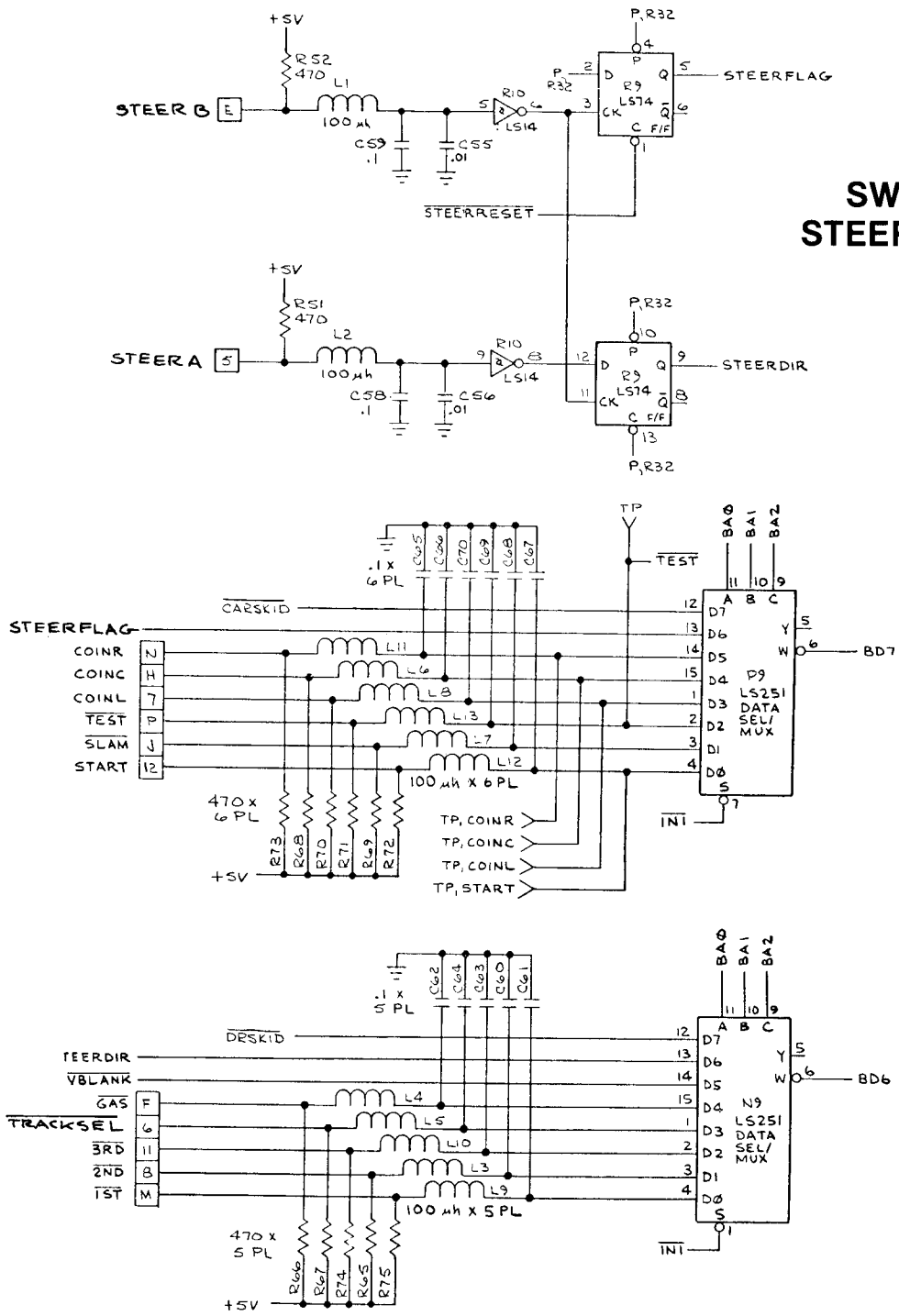
HEXADECIMAL	ADDRESS																R/W	DATA								FUNCTION
	A15	A14	A13	A12	A11	A10	A9	A8	A7	A6	A5	A4	A3	A2	A1	A0		D7	D6	D5	D4	D3	D2	D1	D0	
0000-00FF	0	0	0						A	A	A	A	A	A	A	A		D	D	D	D	D	D	D	D	PAGE ZERO RAM
00FE-003F	0	0	0						0	0	A	A	A	A	A	A		D	D	D	D	D	D	D	D	ALPHA-NUMERICS
0800-08FF	0	0	1						A	A	A	A	A	A	A	A		D	D	D	D	D	D	D	D	PLAYFIELD RAM
1000	0	1	0	0					0	0	0						W	D	D	D	D	D	D	D	D	PLAYFIELD VERT POS
1020	0	1	0	0					0	0	1						W	D	D	D	D	D	D	D	D	PLAYFIELD HORIZ POS
1040	0	1	0	0					0	1	0						W									DRONE CRASH RESET
1060	0	1	0	0					0	1	1						W									CAR CRASH RESET
1080	0	1	0	0					1	0	0						W									DRONE COLOR 2, CAR ROTATION
10A0	0	1	0	0					1	0	1						W									STEER RESET
10C0	0	1	0	0					1	1	0						W									WATCHDOG RESET
10E0	0	1	0	0					1	1	1						W									SKID RESET
1400	0	1	0	1					0	0	0						W	D	D	D	D	D	D	D	D	MOTOR SOUNDS
1420	0	1	0	1					0	0	1						W	D	D	D	D					CRASH SOUNDS
1440	0	1	0	1					0	1	0						W									SKID SOUND ON
1460	0	1	0	1					0	1	1						W	D	D	D	D	D	D	D	D	DRONE HORIZ POS
1480	0	1	0	1					1	0	0						W	D	D	D	D	D	D	D	D	DRONE VERT POS
14A0	0	1	0	1					1	0	1						W	D	D	D	D	D	D	D	D	DRONE COLOR 1, ROTATION
14C0	0	1	0	1					1	1	0						W	D	D	D						COIN COUNTERS (L.C.R.—1 = ON)
14C0	0	1	0	1					1	1	0						W					D				ATTRACT (0 = ATTRACT)
14C0	0	1	0	1					1	1	0						W						D			TRACK SEL LAMP (0 = ON)
14C0	0	1	0	1					1	1	0						W							D		START LAMP (0 = ON)
14E0	0	1	0	1					1	1	1						W	D		D					D	VIDEO INVERT (1 = ON) BEEPER (0 = ON)
14E0	0	1	0	1												W					D	D	D	D	DRONE MOTOR LOUDNESS	
1800	0	1	1	0							0	0	0				R	D								START SW (1 = ON)
1800	0	1	1	0							0	0	0				R	D								1st GEAR (1 = ON)
1800	0	1	1	0							0	0	0				R							D		CAR CRASH IN (1 = CRASH)
1800	0	1	1	0							0	0	0				R							D	D	DRONE CRASH IN (1 = CRASH)
1801	0	1	1	0							0	0	1				R	D								SLAM SW (1 = ON)
1801	0	1	1	0							0	0	1				R	D	D							2nd GEAR (1 = ON)
1802	0	1	1	0							0	1	0				R	D								TEST SW (1 = ON)
1802	0	1	1	0							0	1	0				R	D	D							3rd GEAR (1 = ON)
1803	0	1	1	0							0	1	1				R	D								COIN SW (LEFT) (1 = ON)
1803	0	1	1	0							0	1	1				R	D								TRACK SEL SW (1 = ON)
1804	0	1	1	0							1	0	0				R	D								COIN SW (CENTER) (1 = ON)
1804	0	1	1	0							1	0	0				R	D	D							GAS SW (1 = ON)
1805	0	1	1	0							1	0	1				R	D								COIN SW (RIGHT) (1 = ON)
1805	0	1	1	0							1	0	1				R	D	D							VBLANK (1 = TRUE)
1806	0	1	1	0							1	1	0				R	D								STEER FLAG (0 = TRUE)
1806	0	1	1	0							1	1	0				R	D	D							STEER DIR
1807	0	1	1	0							1	1	1				R	D								CAR SKID (1 = ON)
1807	0	1	1	0							1	1	1				R	D	D							DRONE SKID (1 = ON)
1C00	0	1	1	1							0	0					R		D	D	D	D				OPTION
1C00	0	1	1	1							0	0					R						D	D		OPTION
1C01	0	1	1	1							0	1					R						D	D		OPTION
1C02	0	1	1	1							1	0					R						D	D		OPTION
1C03	0	1	1	1							1	1					R						D	D		OPTION
2000-3FFF	1	A	A	A	A	A	A	A	A	A	A	A	A	A	A	A	R	D	D	D	D	D	D	D	D	8K PROGRAM ROM/PROM

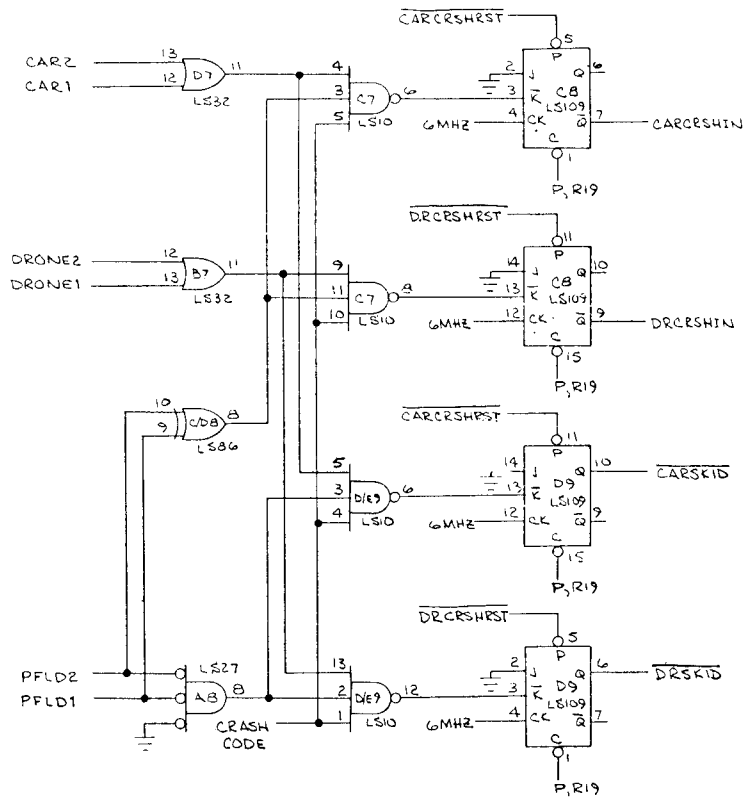
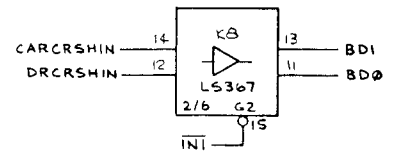
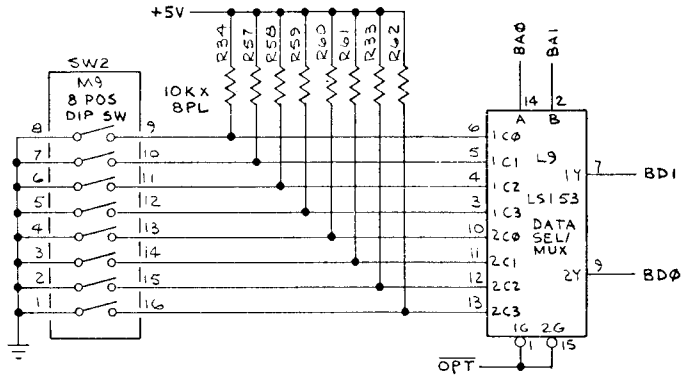
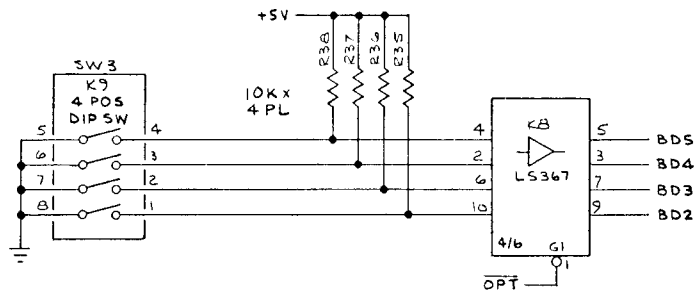


### ADDRESS DECODER AND MEMORY



## SWITCH AND STEERING INPUTS

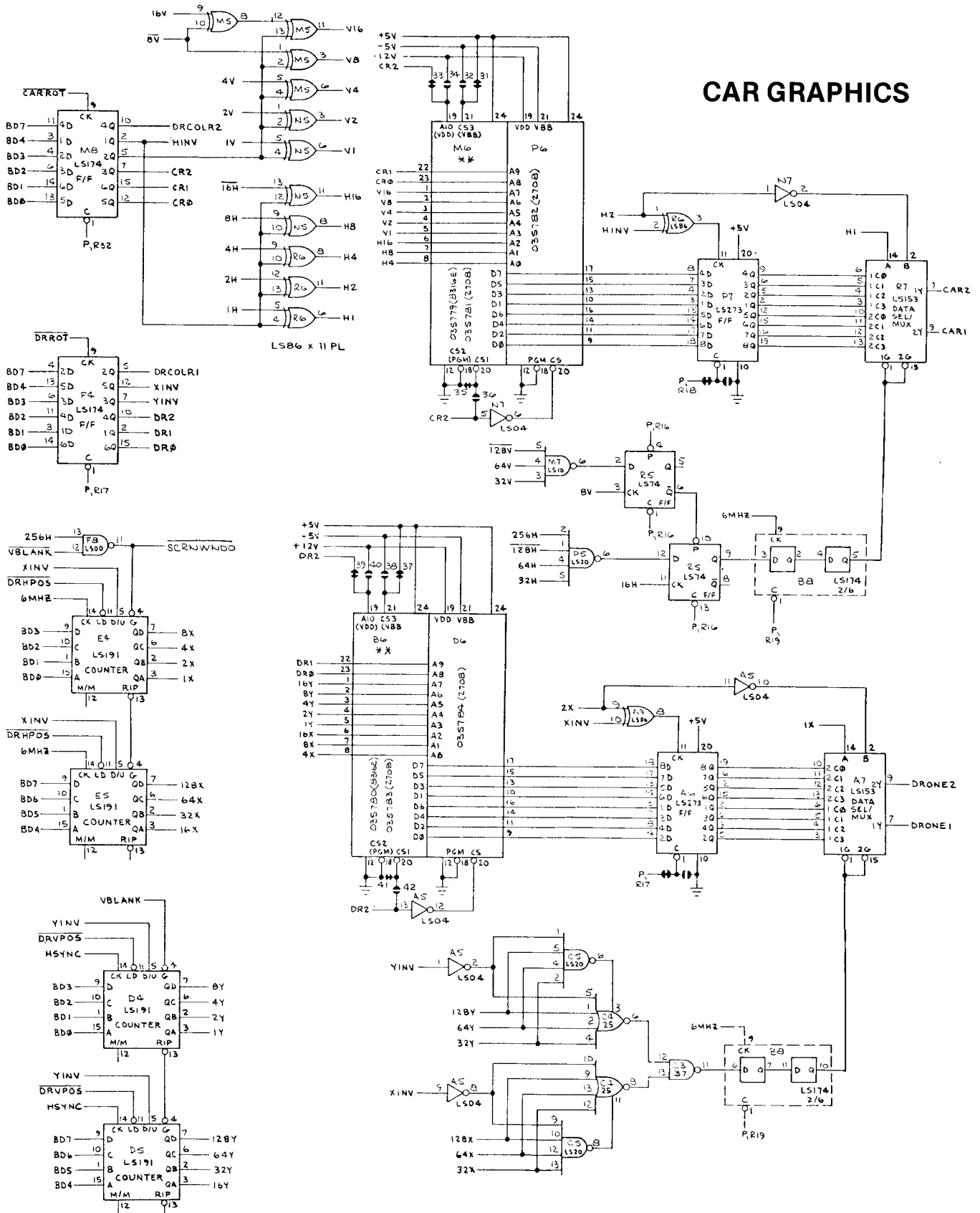




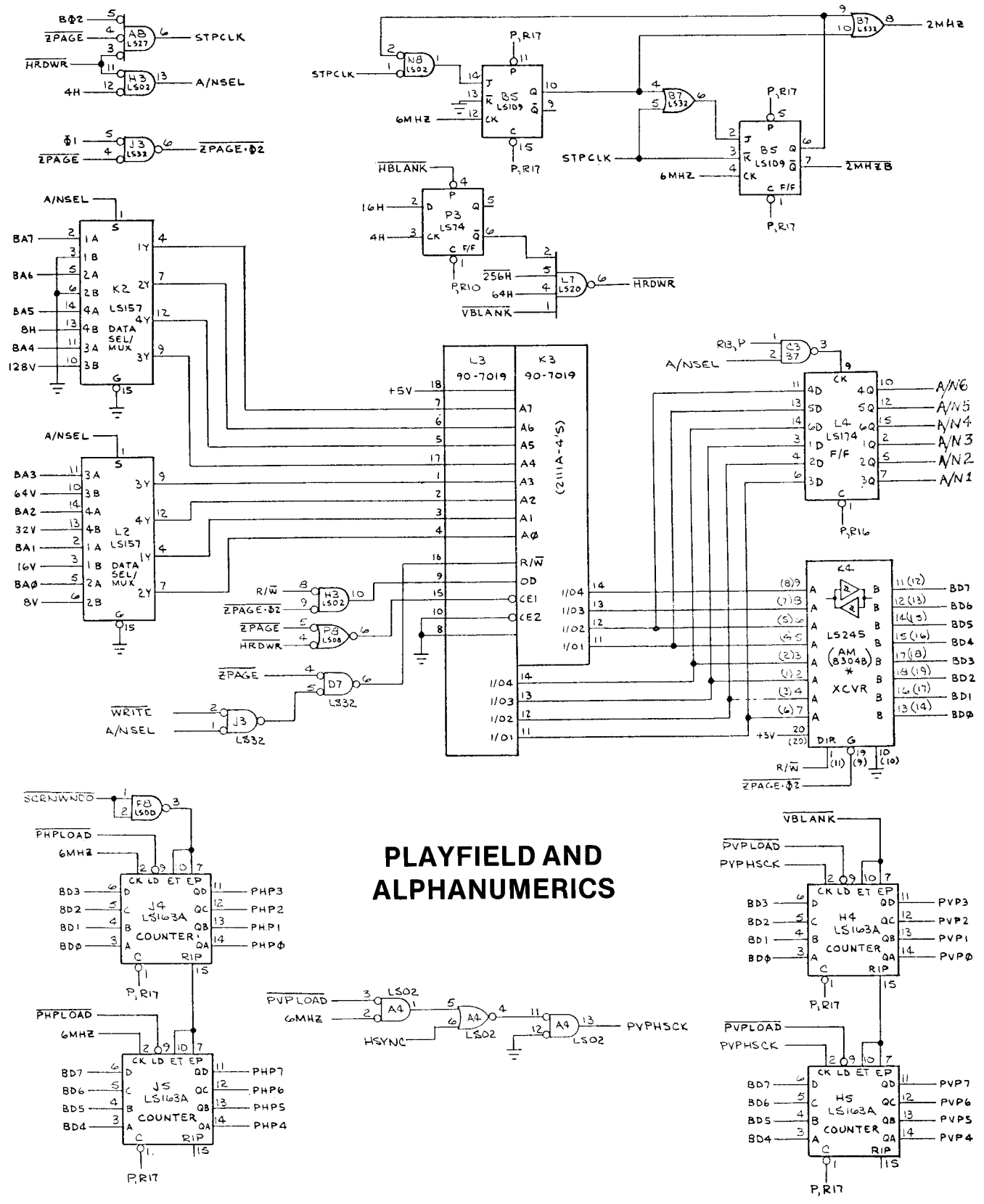
**OPTION AND  
CRASH DETECTOR  
INPUTS**

**Figure 20D Game PCB Schematic (Continued)**

# CAR GRAPHICS

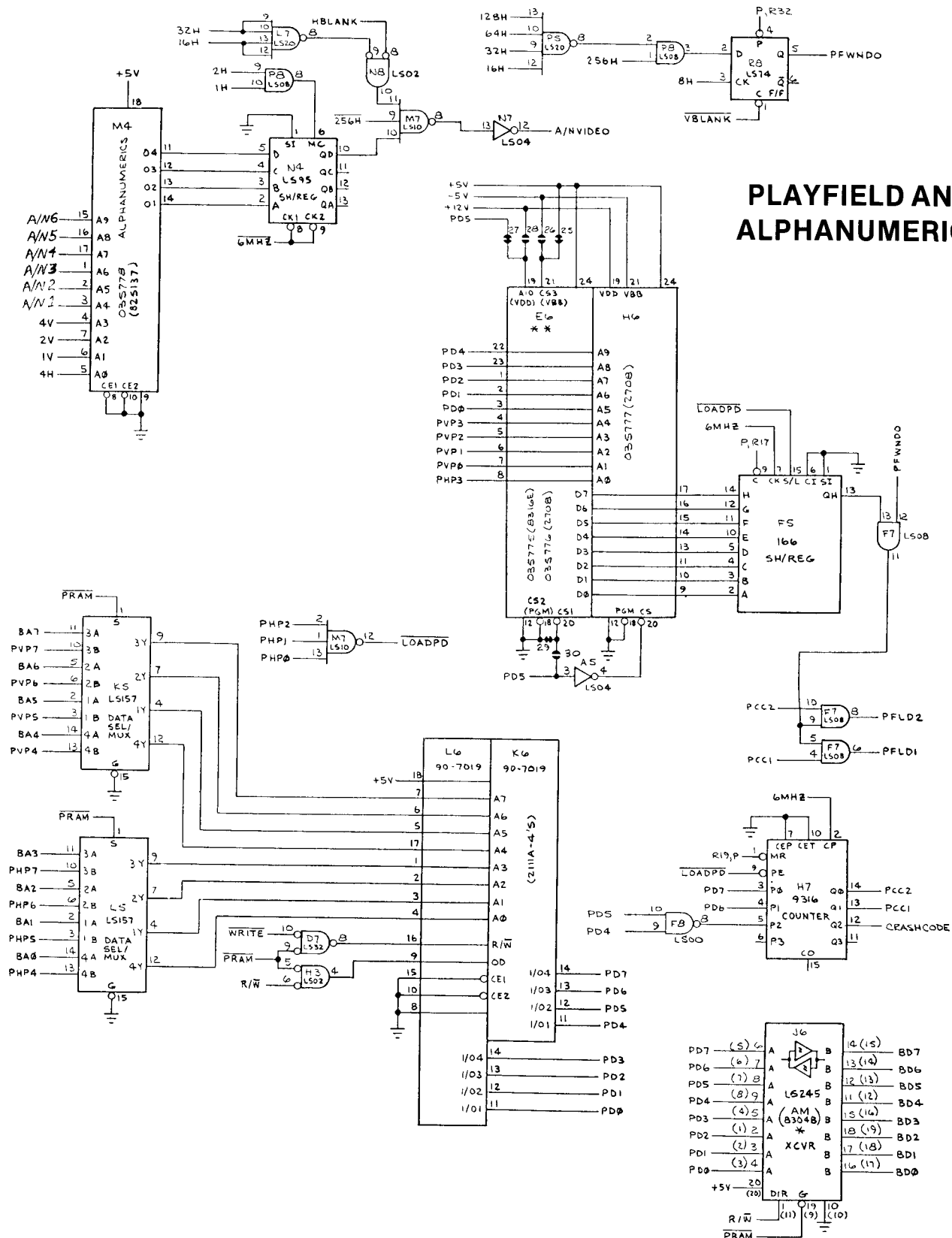






### PLAYFIELD AND ALPHANUMERIC

Figure 20D Game PCB Schematic (Continued)



# AUDIO

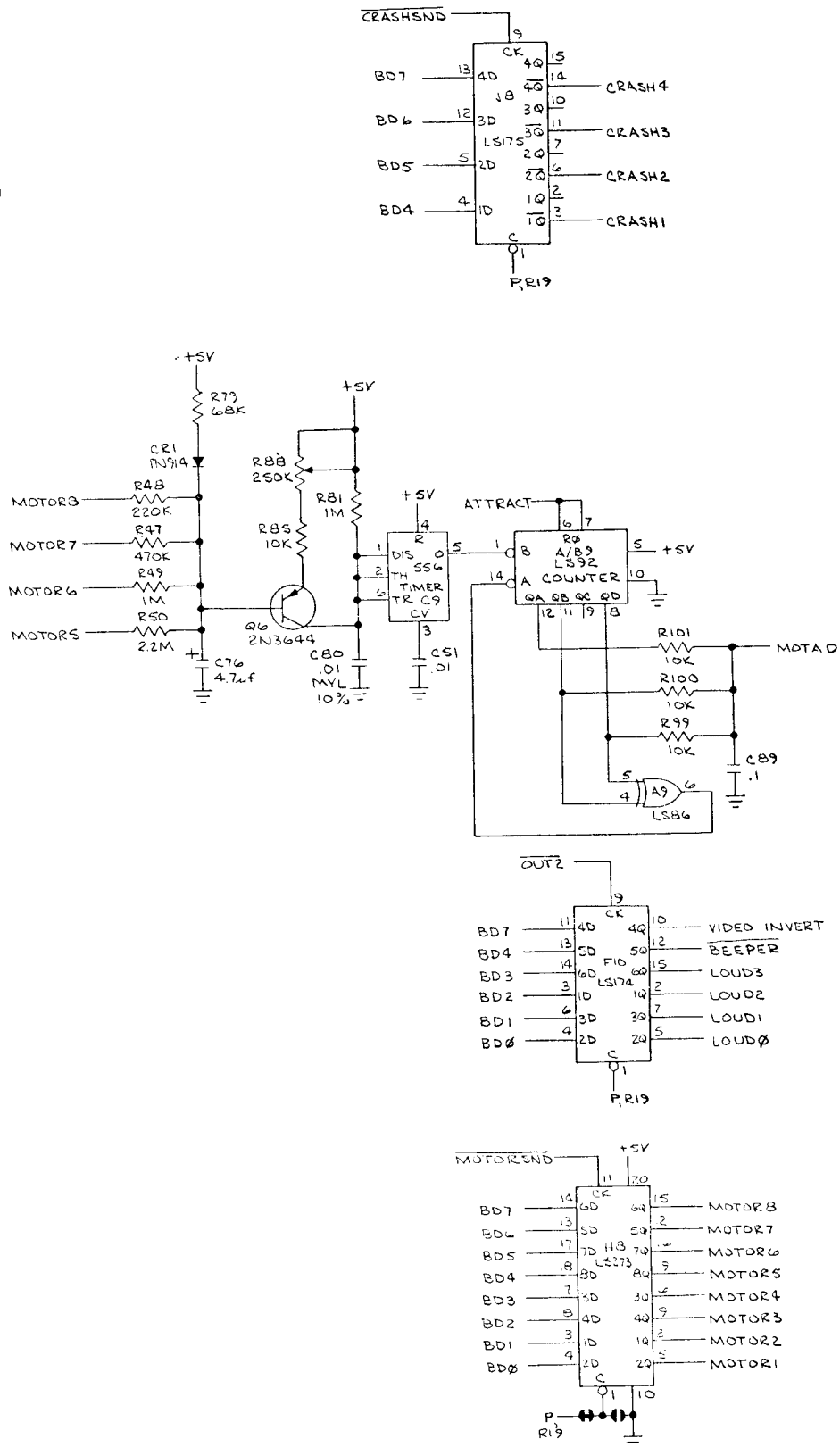
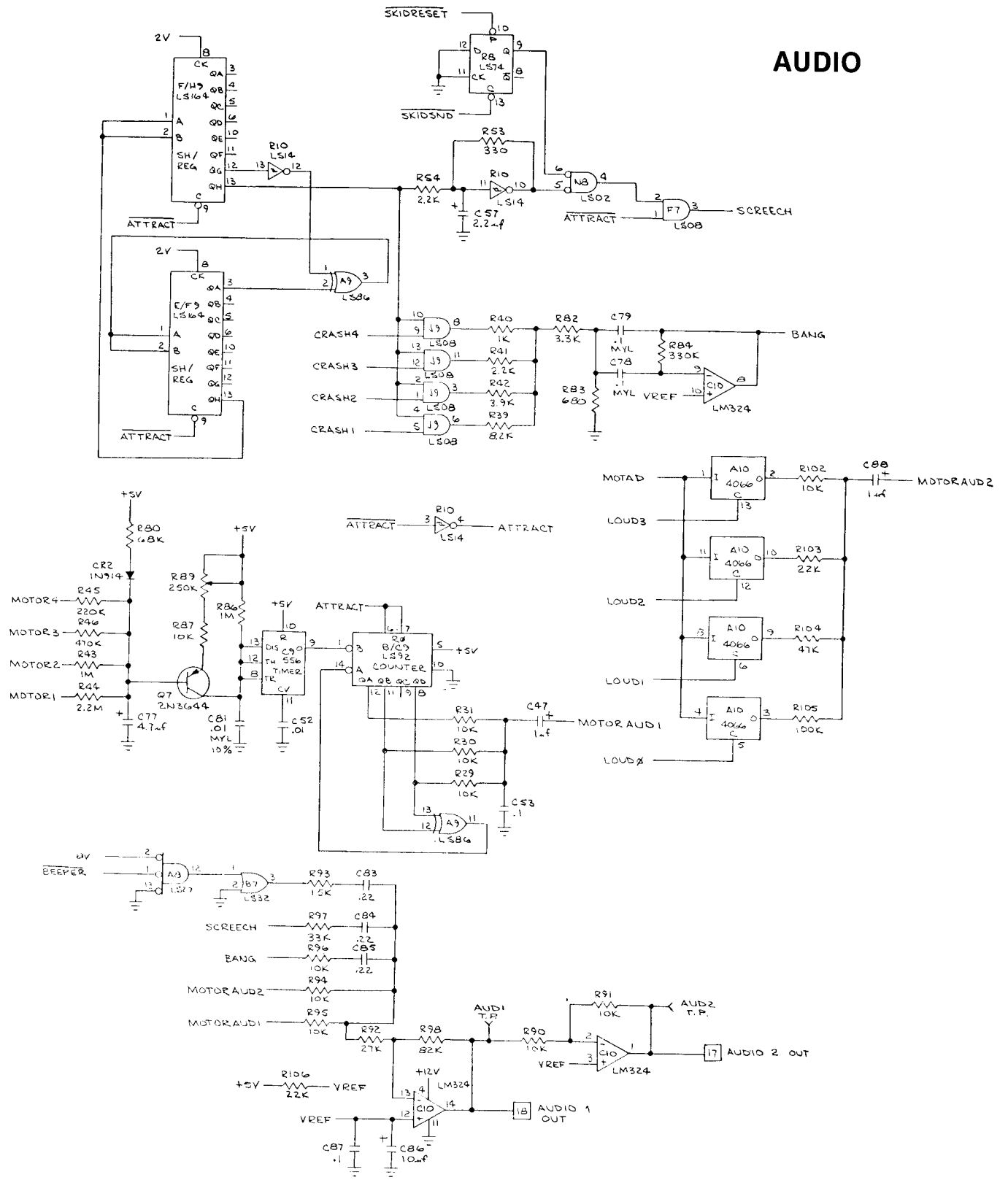
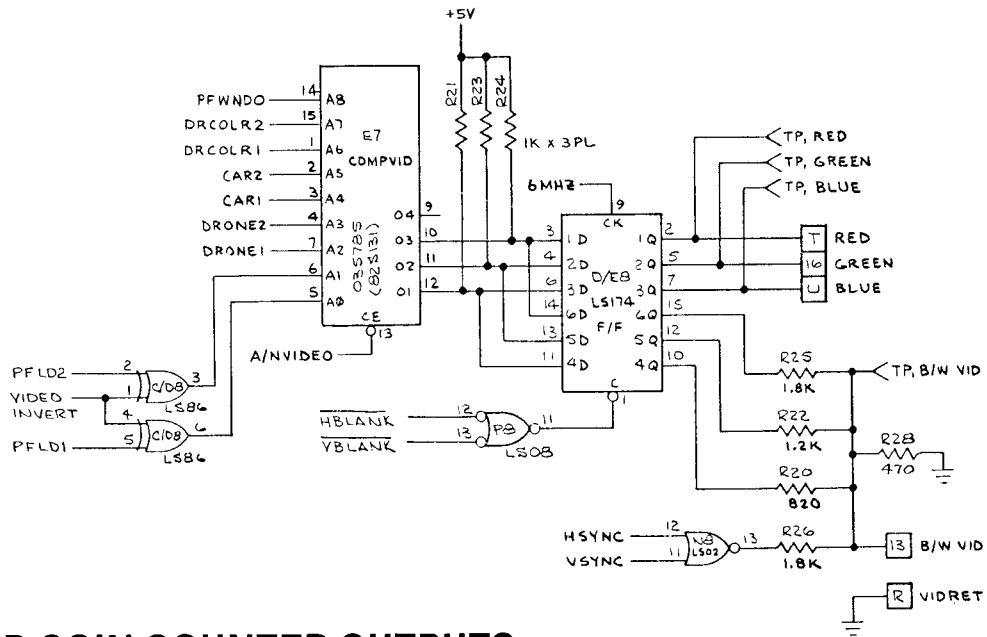


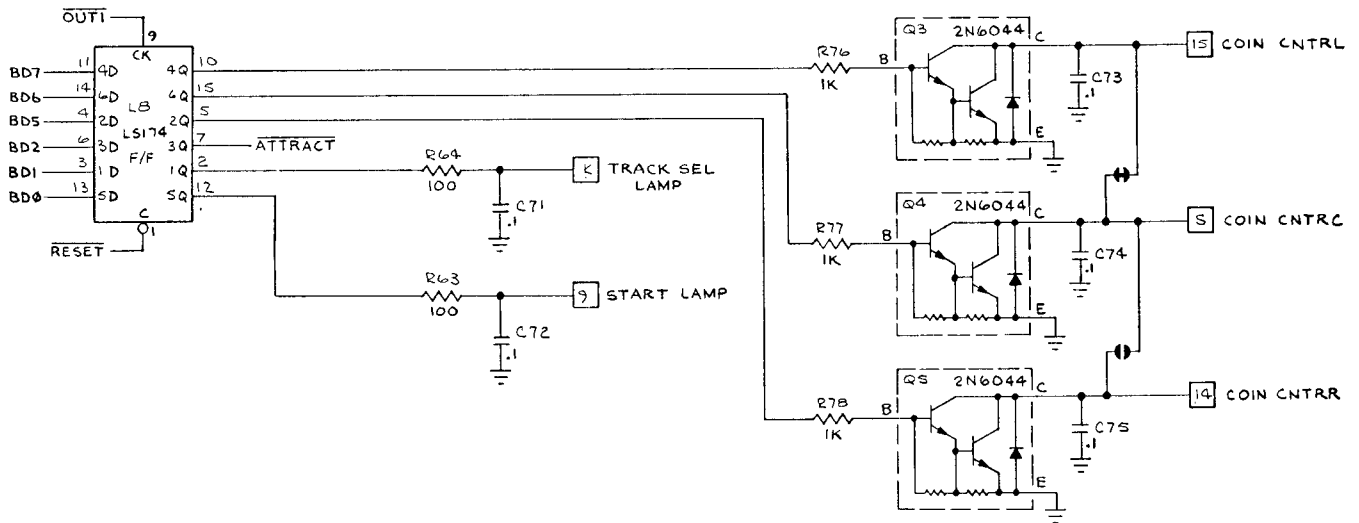
Figure 20D Game PCB Schematic (Continued)

# AUDIO





**VIDEO AND COIN COUNTER OUTPUTS**

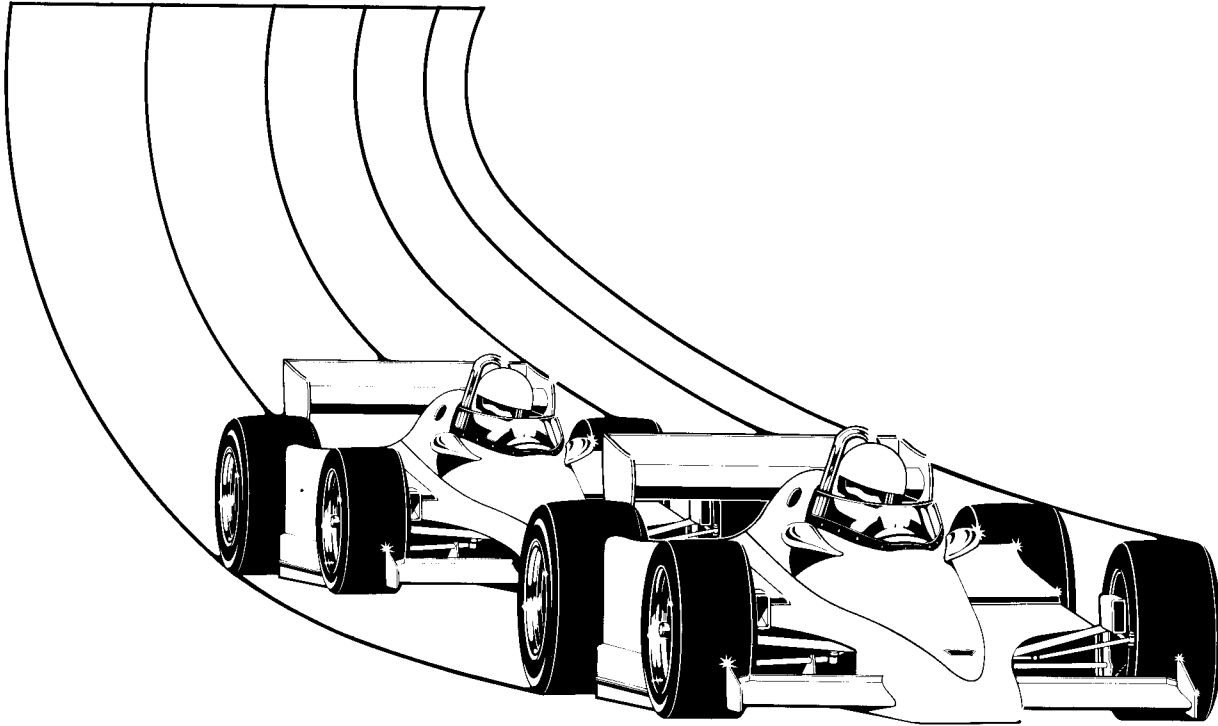


**Figure 20D Game PCB Schematic (Continued)**

The purpose of this chapter is to provide you with the necessary information for ordering replacement parts for your game. Please note that, for simplicity, **common hardware has been deleted** from some of these parts lists. This includes screws, nuts, bolts, washers, etc.

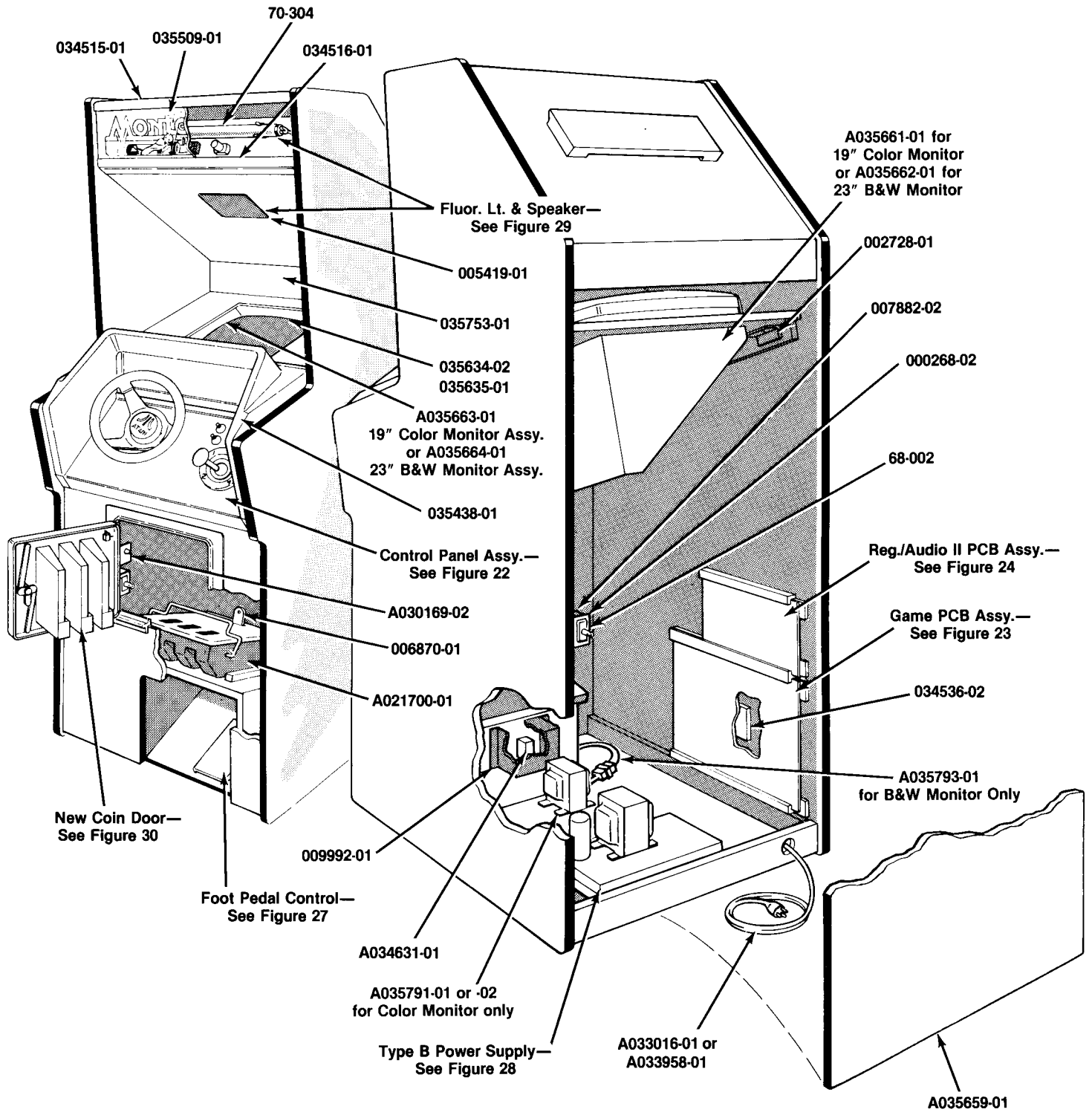
The parts lists have been arranged in alphanumeric order. For example, all "A-" prefix numbers come first. Following this are numbers in sequence evaluated up to the hyphen, namely 00-thru 99-, then 000598- thru approximately 110000-.

When ordering parts from your distributor, give the part number, part name, applicable figure number of this manual, and serial number of your game. This will help to avoid confusion and mistakes in your order. We hope the results will be less downtime and more profit from your game.



## Illustrated Parts Lists





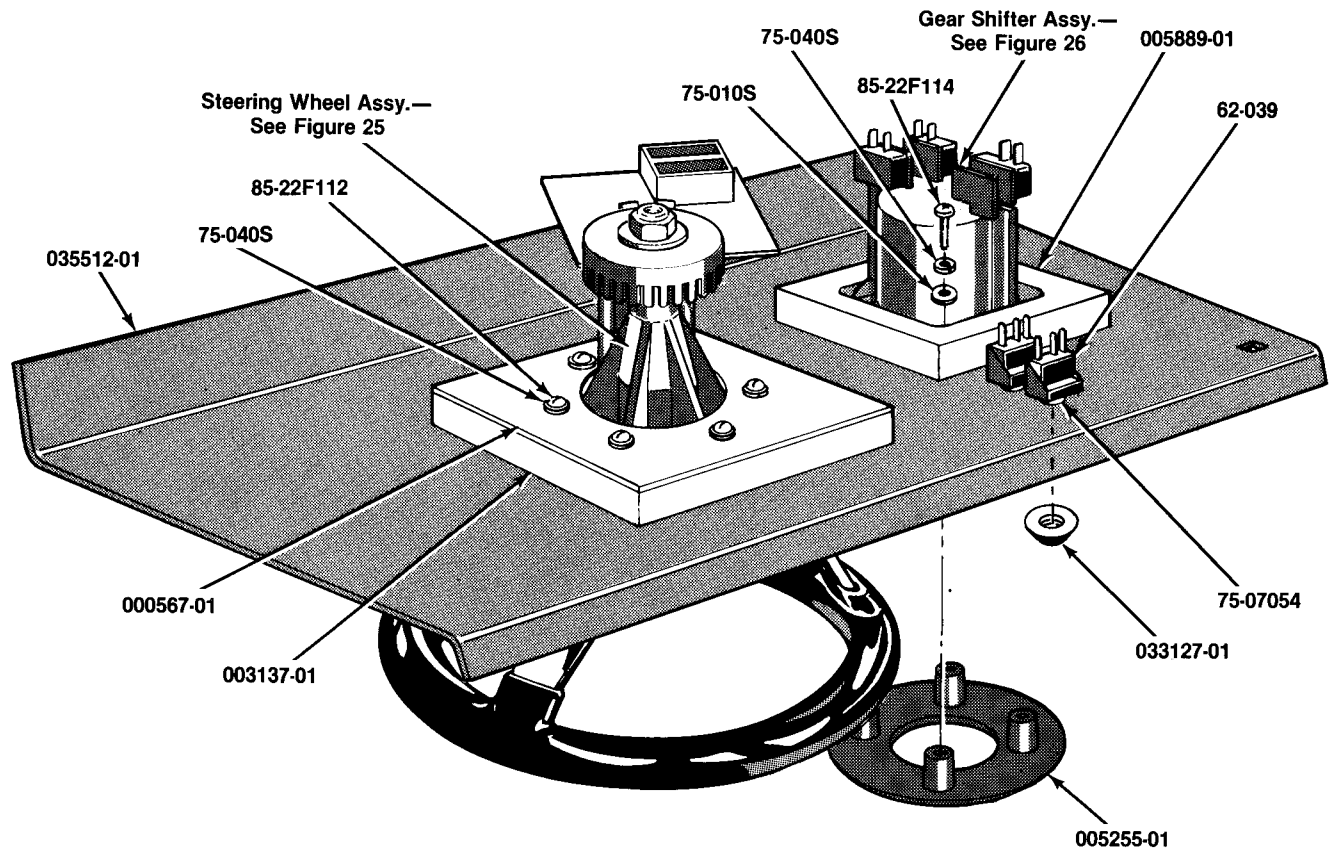
**Figure 21 Final Assembly  
A035656-xx B and A035667-xx B**

## Figure 21 Final Assembly Parts List

Part No.	Description
	Control Panel Assembly—see Figure 22
	Game PCB Assembly—see Figure 23
	Regulator/Audio II PCB Assembly—see Figure 24
	Foot Pedal Control—see Figure 27
	Type B Power Supply Assembly—see Figure 28
	Fluorescent Light and Speaker—see Figure 29
	New Coin Door—see Figure 30
A021700-01	Coin Box Assembly (3 holes)
A030169-02	Volume Control/Bracket Assembly
A030268-01	Coin Box Assembly (2 holes)
A033016-01	Strain Relief Power Cord (domestic)
OR	
A033958-01	Strain Relief Power Cord (German)
A034631-01	On/Off Switch Assembly
A035659-01	Access Panel Assembly
A035663-01	19" Color TV Monitor Assembly (includes wood shelf)
A035664-01	23" Black-and-White TV Monitor Assembly (includes wood shelf)
A035791-01 or -02	Isolation Transformer (for color monitor only)
A035793-01	Monitor Shorting Plug (for b&w monitor only)
DP-149-01	Monte Carlo™ Schematic Drawings, Sheet 1
DP-149-02	Monte Carlo Schematic Drawings, Sheet 2
TM-149	Monte Carlo Operation, Maintenance, Service Manual
TM-148	Instruction and Service Manual for G07-901 R.G.B. Color Monitor
68-002	Interlock Switch (two per game)
70-304	18" 15-Watt Cool White Fluorescent Lamp
71-2114	Panel Cartridge Lock Mechanism (for access panel)
75-07017	Spacer for Mounting Printed-Circuit Boards
78-24012	5" Beaded Nylon Tie Wrap (for Game PCB edge connector)
79-3210	Single-Pole Fuse Block, with ¼" × 1/32" Tab
000268-02	Interlock Switch Mounting Bracket
002728-01	Control-Panel Mounting Bracket
005419-01	Speaker Grille
006870-01	Coin Box Bracket
007882-02	Interlock Switch Cover
009992-01	On/Off Switch Cover
034515-01	Upper Retainer Strip
034516-01	Lower Retainer Strip
034536-02	Foam Vibration Damper
035438-01	Molded Dashboard
035509-01	Attraction Panel with Graphics
035634-02	Monitor Shield without Graphics (smoke color)
035635-01	Monitor Shield with Graphics
035661-01	Cardboard Bezel (for 19" color monitor)
035662-01	Cardboard Bezel (for 23" black-and-white monitor)
035723-01	Product Identification Label
035753-01	Graphics Panel with "GO" Design

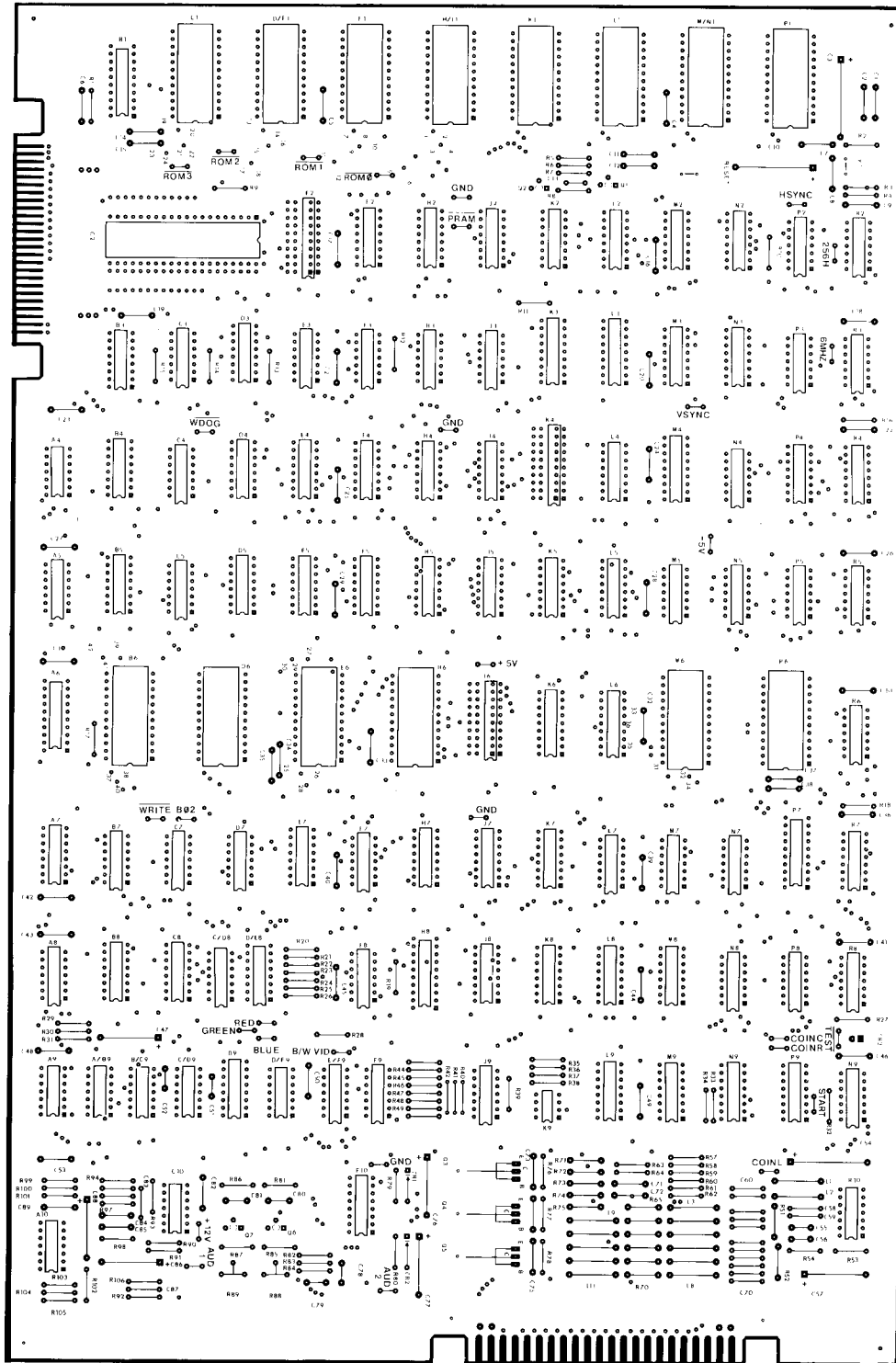






**Figure 22 Control Panel Assembly  
A035657-01 A  
Parts List**

<i>Part No.</i>	<i>Description</i>
	Steering Wheel Assembly—see Figure 25
	Gear Shifter Assembly—see Figure 26
62-039	SPDT Momentary Pushbutton Switch, with Red Cap and Light-Emitting Diode
75-010S	#10 Plain Flat Regular-Pattern Steel Washer
75-040S	#10 Steel Split Lock Washer
75-07054	Flat Nylon Washer, 0.470" inside diameter × 0.968" outside diameter × 0.075" thick
85-22F112	#10-24 × ¾" Pan-Head Phillips Self-Threading Type F Steel Machine Screw
85-22F114	#10-24 × 7/8" Pan-Head Phillips Self-Threading Type F Steel Machine Screw
000567-01	Metal Backup Plate for Steering Wheel
003137-01	Wood Backup Panel for Steering Wheel
005255-01	Shift Bezel ("H" Pattern)
005889-01	Wood Backup Panel for Gear Shifter
033127-01	Black Molded Switch Bushing
035512-01	Control Panel with Graphics



**Figure 23 Game PCB Assembly  
A035675-01 and -02 A**

## Figure 23 Game PCB Assembly Parts List

<i>Part No.</i>	<i>Description (Reference Designations and Locations in Bold)</i>
10-5225	2.2M Ohm, $\pm 5\%$ , 1/4W Resistor <b>(R44, 50)</b>
19-315254	250K Ohm Vertical PCB-Mounting Cermet Trimpot <b>(R88, 89)</b>
21-101103	.01 uf, $\pm 10\%$ , Radial-Lead Epoxy-Dipped 100V Mylar Capacitor <b>(C80, 81)</b>
21-101104	.1 uf, $\pm 10\%$ , Radial-Lead Epoxy-Dipped 100V Mylar Capacitor <b>(C78, 79)</b>
24-250105	1 uf Aluminum Electrolytic Fixed Axial-Lead 25V Capacitor <b>(C47, 88)</b>
24-250106	10 uf Aluminum Electrolytic Fixed Axial-Lead 25V Capacitor <b>(C86)</b>
24-250107	100 uf Aluminum Electrolytic Fixed Axial-Lead 25V Capacitor <b>(C3, 10, 54)</b>
24-250225	2.2 uf Aluminum Electrolytic Fixed Axial-Lead 25V Capacitor <b>(C57)</b>
24-250475	4.7 uf Aluminum Electrolytic Fixed Axial-Lead 25V Capacitor <b>(C76, 77)</b>
27-250102	.001 uf Ceramic-Disc 25V Radial-Lead Capacitor <b>(C13)</b>
27-250103	.01 uf Ceramic-Disc 25V Radial-Lead Capacitor <b>(C51, 52, 55, 56)</b>
27-250224	.22 uf Ceramic-Disc 25V Radial-Lead Capacitor <b>(C83-85)</b>
29-088	.1 uf Ceramic-Disc 25V Radial-Lead Capacitor <b>(C1, 2, 4-9, 11, 12, 14-46, 48-50, 53, 58-75, 82, 87, 89)</b>
31-1N914	75V 1N914 Switching Diode <b>(CR1, 2)</b>
33-2N3644	Type 2N3644 PNP 25V Transistor <b>(Q1, 6, 7)</b>
34-2N3643	Type 2N3643 NPN Switching Transistor <b>(Q2)</b>
34-2N6044	Type 2N6044 NPN Darlington Transistor <b>(Q3-5)</b>
37-LM324	Type LM324 Integrated Circuit <b>(C10)</b>
37-4066	Type 4066 Integrated Circuit <b>(A10)</b>
37-556	Type 556 Timer Integrated Circuit <b>(C9)</b>
37-74LS00	Type 74LS00 Integrated Circuit <b>(F3, F8)</b>
37-74LS02	Type 74LS02 Integrated Circuit <b>(H3, N8, A4)</b>
37-74LS04	Type 74LS04 Integrated Circuit <b>(R2, A5, N7)</b>
37-74LS08	Type 74LS08 Integrated Circuit <b>(F7, P8, J9)</b>
37-74LS10	Type 74LS10 Integrated Circuit <b>(C7, M7, D/E9)</b>
37-74LS14	Type 74LS14 Integrated Circuit <b>(E3, R10)</b>
37-74LS20	Type 74LS20 Integrated Circuit <b>(C5, P5, L7)</b>
37-74LS27	Type 74LS27 Integrated Circuit <b>(A8)</b>
37-74LS32	Type 74LS32 Integrated Circuit <b>(J3, B7, D7)</b>
37-74LS42	Type 74LS42 Integrated Circuit <b>(H2, J2, J7, K7)</b>
37-74LS74	Type 74LS74 Integrated Circuit <b>(P2, P3, R3, R5, R8, R9)</b>
37-74LS86	Type 74LS86 Integrated Circuit <b>(M5, N5, R6, C/D8, A9)</b>
37-74LS92	Type 74LS92 Integrated Circuit <b>(A/B9, B/C9)</b>
37-74LS95	Type 74LS95 Integrated Circuit <b>(N4)</b>
37-74LS109	Type 74LS109 Integrated Circuit <b>(B3, B5, C8, D9)</b>
37-74LS153	Type 74LS153 Integrated Circuit <b>(A7, R7, L9)</b>
37-74LS157	Type 74LS157 Integrated Circuit <b>(K2, L2, B4, K5, L5)</b>
37-74LS163A	Type 74LS163A Integrated Circuit <b>(M2, N2, P4, R4, H4, J4, H5, J5)</b>
37-74LS164	Type 74LS164 Integrated Circuit <b>(E/F9, F/H9)</b>
37-74LS174	Type 74LS174 Integrated Circuit <b>(F4, L4, B8, D/E8, L8, M8, F10)</b>
37-74LS175	Type 74LS175 Integrated Circuit <b>(M3, J8)</b>
37-74LS191	Type 74LS191 Integrated Circuit <b>(D4, E4, D5, E5)</b>
37-74LS244 †	Type 74LS244 Integrated Circuit <b>(B1)</b>
37-74LS245 ‡	Type 74LS245 Integrated Circuit <b>(E2, K4, J6)</b>
37-74LS251	Type 74LS251 Integrated Circuit <b>(N9, P9)</b>
37-74LS273 §	Type 74LS273 Integrated Circuit <b>(A6, P7, H8)</b>
37-74LS367	Type 74LS367 Integrated Circuit <b>(F2, K8)</b>
37-74166	Type 74166 Integrated Circuit <b>(F5)</b>
37-7425	Type 7425 Integrated Circuit <b>(C4)</b>
37-7437	Type 7437 Integrated Circuit <b>(C3)</b>
37-7496	Type 7496 Integrated Circuit <b>(D3)</b>
37-9316	Type 9316 Integrated Circuit <b>(H7)</b>

† This item may be substituted by part no. 37-74LS241, a type 74LS241 Integrated Circuit **(B1)**

‡ This item may be substituted by part no. 37-8304B, a type 8304B Integrated Circuit **(E2, K4, J6)**

§ This item may be substituted by part no. 37-74LS374, a type 74LS374 Integrated Circuit **(A6, P7, H8)**

## Figure 23 Game PCB Assembly Parts List

<i>Part No.</i>	<i>Description (Reference Designations and Locations in Bold)</i>
37-MV5053	Type MV5053 Light-Emitting Diode <b>(CR3)</b>
41-3003	100 uH, ± 5%, Hot-Molded Plastic Fixed R.F. Choke <b>(L1-L13)</b>
62-001	SPST Pushbutton Switch <b>(SW1)</b>
66-114P1T	4-Station Single-Throw, Dual-Inline-Package Bit Switch <b>(SW3)</b>
66-118P1T	8-Station Single-Throw, Dual-Inline-Package Bit Switch <b>(SW2)</b>
79-42C40	40-Contact Medium-Insertion-Force Integrated Circuit Socket <b>(C2)</b>
81-4302	Nylon Snap-In Fastener
90-102	12.096 MHz, ± .005%, Crystal <b>(Y1)</b>
90-6001	Microprocessor <b>(C2)</b>
90-7019	Random-Access Memory <b>(K3, L3, K6, L6)</b>
009114-01	Programmable Read-Only Memory—Sync <b>(N3)</b>
020670-01	Test Point
035778-01	Programmable Read-Only Memory—Alphanumerics <b>(M4)</b>
035785-01	Programmable Read-Only Memory—Grey Levels and Color Video <b>(E7)</b>
110000-101	100 Ohm, ± 5%, ¼ W Resistor <b>(R63, 64)</b>
110000-102	1K Ohm, ± 5%, ¼ W Resistor <b>(R9-13, 16-19, 21, 23, 24, 32, 40, 76-78)</b>
110000-103	10K Ohm, ± 5%, ¼ W Resistor <b>(R1, 8, 29-31, 33-38, 57-62, 85, 87, 90, 91, 94-96, 99-102)</b>
110000-104	100K Ohm, ± 5%, ¼ W Resistor <b>(R105)</b>
110000-105	1M Ohm, ± 5%, ¼ W Resistor <b>(R6, 43, 49, 81, 86)</b>
110000-122	1.2K Ohm, ± 5%, ¼ W Resistor <b>(R22)</b>
110000-151	150 Ohm, ± 5%, ¼ W Resistor <b>(R27)</b>
110000-153	15K Ohm, ± 5%, ¼ W Resistor <b>(R5, 93)</b>
110000-182	1.8K Ohm, ± 5%, ¼ W Resistor <b>(R25, 26)</b>
110000-222	2.2K Ohm, ± 5%, ¼ W Resistor <b>(R41, 54)</b>
110000-223	22K Ohm, ± 5%, ¼ W Resistor <b>(R103, 106)</b>
110000-224	220K Ohm, ± 5%, ¼ W Resistor <b>(R45, 48)</b>
110000-271	270 Ohm, ± 5%, ¼ W Resistor <b>(R14, 15)</b>
110000-273	27K Ohm, ± 5%, ¼ W Resistor <b>(R92)</b>
110000-331	330 Ohm, ± 5%, ¼ W Resistor <b>(R2, 4, 53)</b>
110000-332	3.3K Ohm, ± 5%, ¼ W Resistor <b>(R82)</b>
110000-333	33K Ohm, ± 5%, ¼ W Resistor <b>(R97)</b>
110000-334	330K Ohm, ± 5%, ¼ W Resistor <b>(R84)</b>
110000-392	3.9K Ohm, ± 5%, ¼ W Resistor <b>(R42)</b>
110000-471	470 Ohm, ± 5%, ¼ W Resistor <b>(R3, 28, 51, 52, 65-75)</b>
110000-473	47K Ohm, ± 5%, ¼ W Resistor <b>(R104)</b>
110000-474	470K Ohm, ± 5%, ¼ W Resistor <b>(R46, 47)</b>
110000-563	56K Ohm, ± 5%, ¼ W Resistor <b>(R7)</b>
110000-681	680 Ohm, ± 5%, ¼ W Resistor <b>(R83)</b>
110000-683	68K Ohm, ± 5%, ¼ W Resistor <b>(R79, 80)</b>
110000-821	820 Ohm, ± 5%, ¼ W Resistor <b>(R20)</b>
110000-822	8.2K Ohm, ± 5%, ¼ W Resistor <b>(R39)</b>
110000-823	82K Ohm, ± 5%, ¼ W Resistor <b>(R98)</b>

*For remaining memory components and their  
part numbers, see list below.*

## Figure 23 Game PCB Assembly, continued Parts List

### *Memory Components and Their Equivalents (Locations Shown in Bold)*

If PROM is bad, self-test will display the following:	-01 P.C. Boards (PROMs)	-02 P.C. Boards (ROMs)	If ROM is bad, self-test will display the following:
<b>G</b>	035767-01 <b>C1</b>	035763-01 <b>C1</b>	<b>G H</b> (If self-test portion of this chip is bad, bottom area of screen shows garbage and test pattern will scroll sideways.)
<b>H</b> (If self-test portion of this chip is bad, bottom area of screen shows garbage and test pattern will scroll sideways.)	035771-01 <b>J/K1</b>		
<b>E</b>	035768-01 <b>D/E1</b>	035764-01 <b>D/E1</b>	<b>E F</b>
<b>F</b>	035772-01 <b>L1</b>		
<b>C</b>	035769-01 <b>F1</b>	035765-01 <b>F1</b>	<b>C D</b>
<b>D</b>	035773-01 <b>M1</b>		
<b>A</b>	035770-01 <b>H1</b>	035766-01 <b>H1</b>	<b>A B</b>
<b>B</b>	035774-01 <b>N/P1</b>		
Incomplete test pattern of people, cola stands, trees, bushes, hay bales, Atari copyright notice, etc. (for the correct test pattern see Figure 6).	035776-01 <b>E6</b> 035777-01 <b>H6</b>	035775-01 <b>E6</b>	Incomplete test pattern of people, cola stands, trees, bushes, hay bales, Atari copyright notice, etc. (for the correct test pattern see Figure 6).
Incomplete red player car (in center of screen). For correct test pattern see Figure 6.	035781-01 <b>M6</b> 035782-01 <b>P6</b>	035779-01 <b>M6</b>	Incomplete red player car (in center of screen). For correct test pattern see Figure 6.
Incomplete computer car (labeled number "0"). For correct test pattern see Figure 6.	035783-01 <b>B6</b> 035784-01 <b>D6</b>	035780-01 <b>B6</b>	Incomplete computer car (labeled number "0"). For correct test pattern see Figure 6.

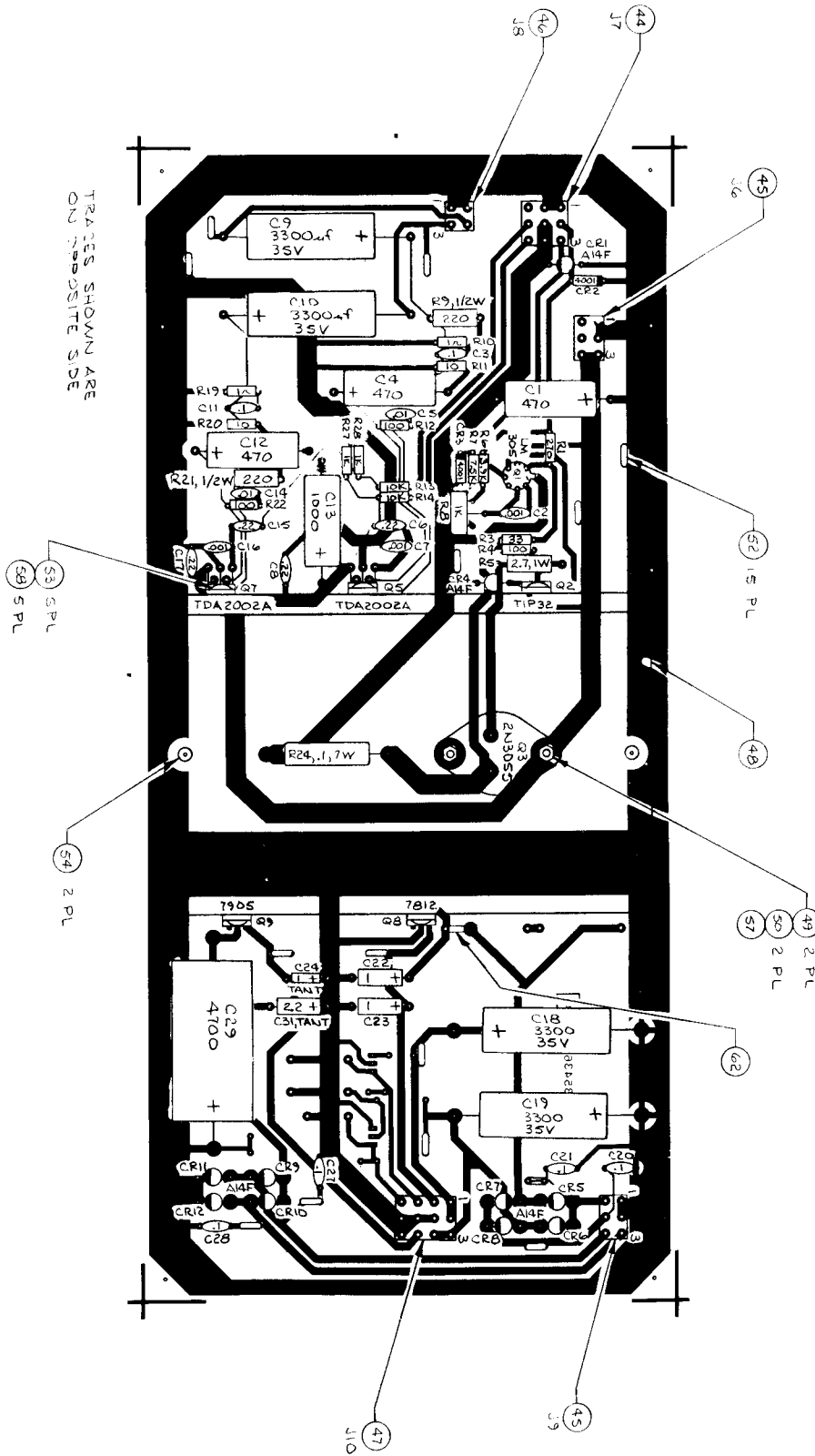
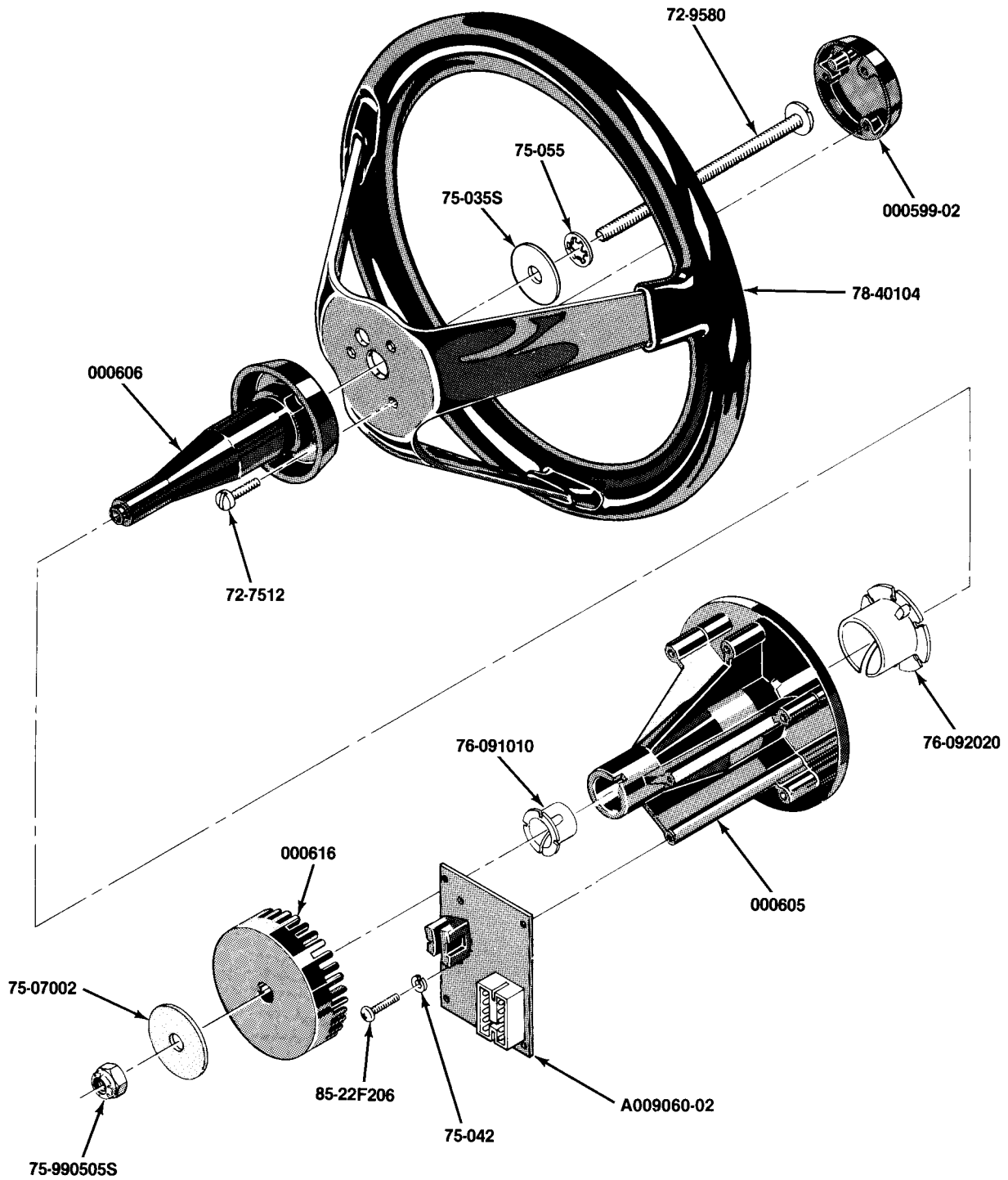


Figure 24 Regulator/Audio II PCB Assembly  
A035435-03 A



## Figure 24 Regulator/Audio II PCB Assembly Parts List

Part No.	Description (Reference Designations and Locations in Bold)
12-52P7	2.7 Ohm, $\pm$ 5%, 1W Resistor <b>(R5)</b>
19-100P1015	.1 Ohm, $\pm$ 3%, 7W Wirewound Resistor <b>(R24)</b>
19-315102	1K Ohm Vertical PCB-Mounting Cermet Trimpot <b>(R8)</b>
24-250108	1000 uf Aluminum Electrolytic Fixed Axial-Lead 25V Capacitor <b>(C13)</b>
24-250477	470 uf Aluminum Electrolytic Fixed Axial-Lead 25V Capacitor <b>(C1, 4, 12)</b>
24-250478	4700 uf Aluminum Electrolytic Fixed Axial-Lead 25V Capacitor <b>(C29)</b>
24-350338	3300 uf Aluminum Electrolytic Fixed Axial-Lead 35V Capacitor <b>(C9, 10, 18, 19)</b>
24-500105	1 uf Aluminum Electrolytic Fixed Axial-Lead 50V Capacitor <b>(C22, 23)</b>
27-250102	.001 uf Ceramic-Disc 25V Radial-Lead Capacitor <b>(C2, 7, 16)</b>
27-250103	.01 uf Ceramic-Disc 25V Radial-Lead Capacitor <b>(C5, 6, 14, 15)</b>
27-250104	.1 uf Ceramic-Disc 25V Radial-Lead Capacitor <b>(C3, 11, 20, 21, 27, 28)</b>
27-250224	.22 uf Ceramic-Disc 25V Radial-Lead Capacitor <b>(C8, 17)</b>
29-006	1 uf Tantalum 35V Capacitor <b>(C24)</b>
31-A14F	50V 2.5A Miniature Axial-Lead High-Current Rectifier <b>(CR1, 4-12)</b>
31-1N4001	50V Silicon Rectifier 1N4001 Diode <b>(CR2, 3)</b>
33-TIP32	PNP Power Transistor, Type TIP32 <b>(Q2)</b>
34-2N3055	NPN Silicon Transistor, Type 2N3055 <b>(Q3)</b>
34-2N3904	NPN Silicon Transistor, Type 2N3904 <b>(Q4, 6)</b>
37-LM305	5V Linear Voltage Regulator <b>(Q1)</b>
37-TDA2002A	Type TDA2002A 8W Linear Audio Amplifier Integrated Circuit <b>(Q5, 7)</b>
37-7812	+ 12V Voltage Regulator, Type 7812 <b>(Q8)</b>
37-7905	- 5V Voltage Regulator, Type 7905 <b>(Q9)</b>
52-004	Teflon-Insulated Solder-Plated Solid Copper PCB-Mounting Jumper Wire with .3" Centers
72-1608C	#6-32 $\times$ 1/2" Cross-Recessed Pan-Head Corrosion-Resistant Steel Machine Screw
75-F60405	#6-32 $\times$ 1/4" Binder-Head Nylon Screw
75-99516	#6-32 Nut/Washer Assembly
78-16008	Thermally Conductive Compound <b>(Q3)</b>
78-16014	Thermally Conductive Compound <b>(Q2, 5, 7-9)</b>
79-58306	6-Position Connector Receptacle <b>(J6, J9)</b>
79-58308	9-Position Connector Receptacle <b>(J7)</b>
79-58346	12-Position Connector Receptacle <b>(J10)</b>
79-58354	4-Position Connector Receptacle <b>(J8)</b>
020670-01	Test Point
034531-01	Heat Sink
110000-010	1 Ohm, $\pm$ 5%, 1/4W Resistor <b>(R10, 19)</b>
110000-100	10 Ohm, $\pm$ 5%, 1/4W Resistor <b>(R11, 20)</b>
110000-101	100 Ohm, $\pm$ 5%, 1/4W Resistor <b>(R4, 12, 22)</b>
110000-102	1K Ohm, $\pm$ 5%, 1/4W Resistor <b>(R27, 28)</b>
110000-103	10K Ohm, $\pm$ 5%, 1/4W Resistor <b>(R13, 14)</b>
110000-271	270 Ohm, $\pm$ 5%, 1/4W Resistor <b>(R1)</b>
110000-330	33 Ohm, $\pm$ 5%, 1/4W Resistor <b>(R3)</b>
110000-392	3.9K Ohm, $\pm$ 5%, 1/4W Resistor <b>(R6)</b>
110000-752	7.5K Ohm, $\pm$ 5%, 1/4W Resistor <b>(R7)</b>
110001-221	220 Ohm, $\pm$ 5%, 1/2W Resistor <b>(R9, 21)</b>
122000-225	2.2 uf Tantalum 35V Capacitor <b>(C31)</b>



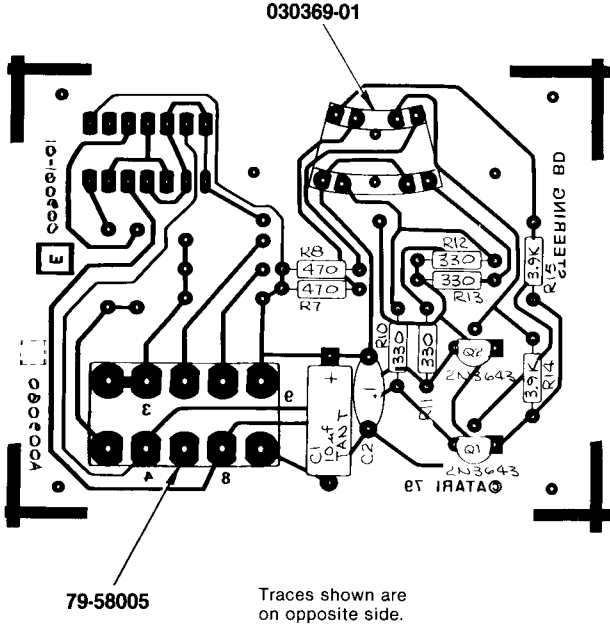
**Figure 25 Steering Wheel Assembly  
A000598-08 U**

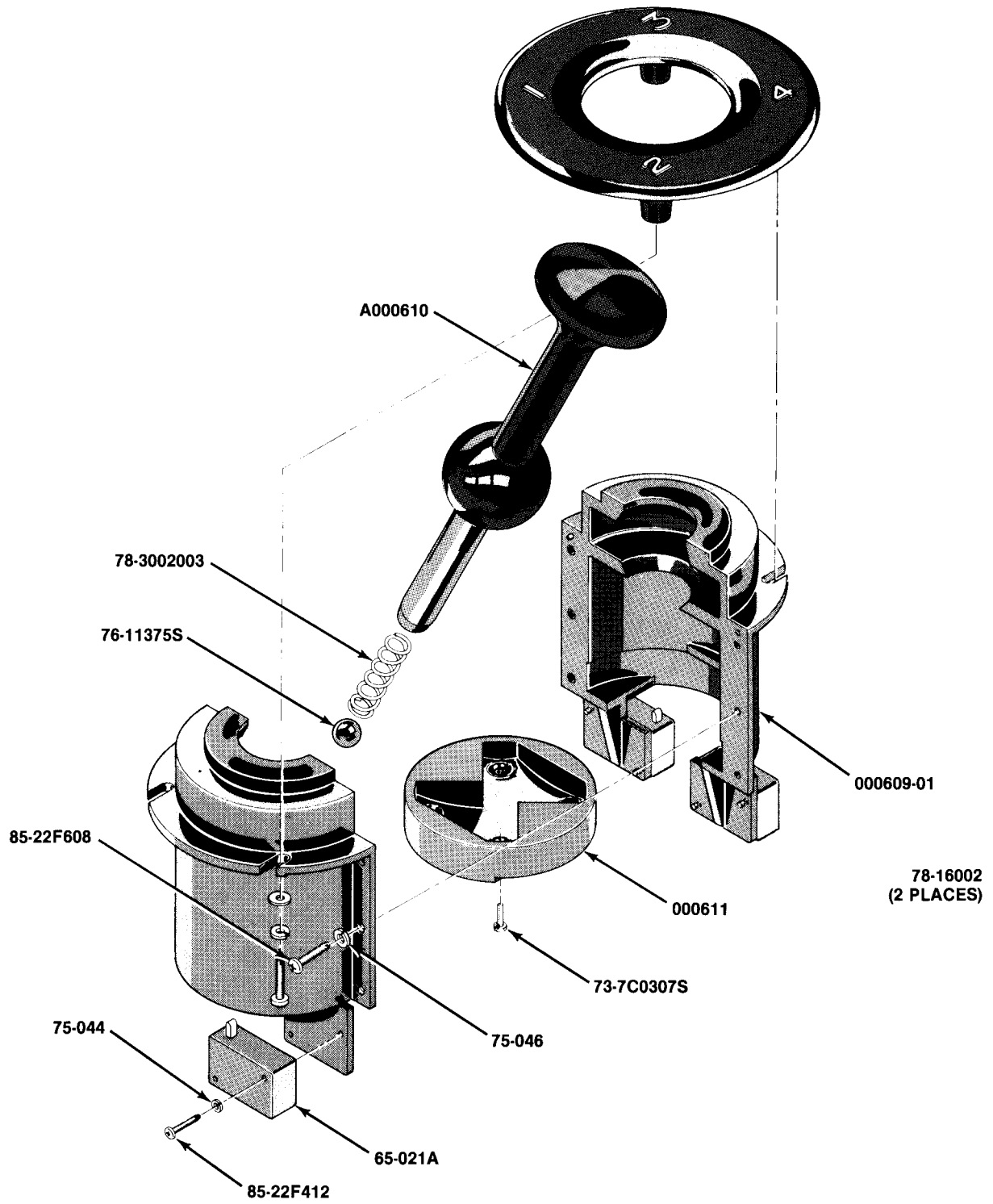


## Figure 25 Steering Wheel Assembly Parts List

Part No.	Description (Reference Designations and Locations in Bold)
A009060-02	Steering Printed-Circuit Board Assembly, consisting of the following eight items:
10-5331	330 Ohm, ± 5%, ¼W Carbon Composition Resistor <b>(R10-13)</b>
10-5392	3.9K Ohm, ± 5%, ¼W Carbon Composition Resistor <b>(R14, 15)</b>
10-5471	470 Ohm, ± 5%, ¼W Carbon Composition Resistor <b>(R7, 8)</b>
27-250104	.1uf 25V Radial-Lead Ceramic-Disc Capacitor <b>(C2)</b>
29-046	10uf 20V Axial-Lead Tantalum Capacitor <b>(C1)</b>
34-2N3643	Type 2N3643 NPN Silicon Transistor <b>(Q1, 2)</b>
79-58005	10-Position Header Connector
030369-01	Radial Optical Coupler
72-7512	#¼-20 × ¾" Fillister-Head Slotted Machine Screw
72-9580	#¼-20 × 5" Truss-Head Slotted Machine Screw
75-042	#2 Corrosion-Resistant Steel Split Lock Washer
75-055	#¼ Internal-Tooth Steel Lock Washer
75-07002	Steel Flat Washer, .281" inside diameter × 1.25" outside diameter × .059" thick
75-990505S	#¼-20 Self-Locking Prevailing-Torque Shallow-Pattern Steel Hex Nut
76-091010	5/8" Inside Diameter Dual-Shouldered Keyed Nylon Journal Bearing
76-092020	1¼" Inside Diameter Dual-Shouldered Keyed Nylon Journal Bearing
78-40104	10" Steering Wheel
85-22F206	#2-56 × 3/8" Pan-Head Phillips Type F Self-Tapping Machine Thread Screw
000599-02	Atari-Logo Cover
000605	Housing
000606	Shaft
000616	Hub Light

*Detail of Steering PCB Assembly, A009060-02, Rev. C:*



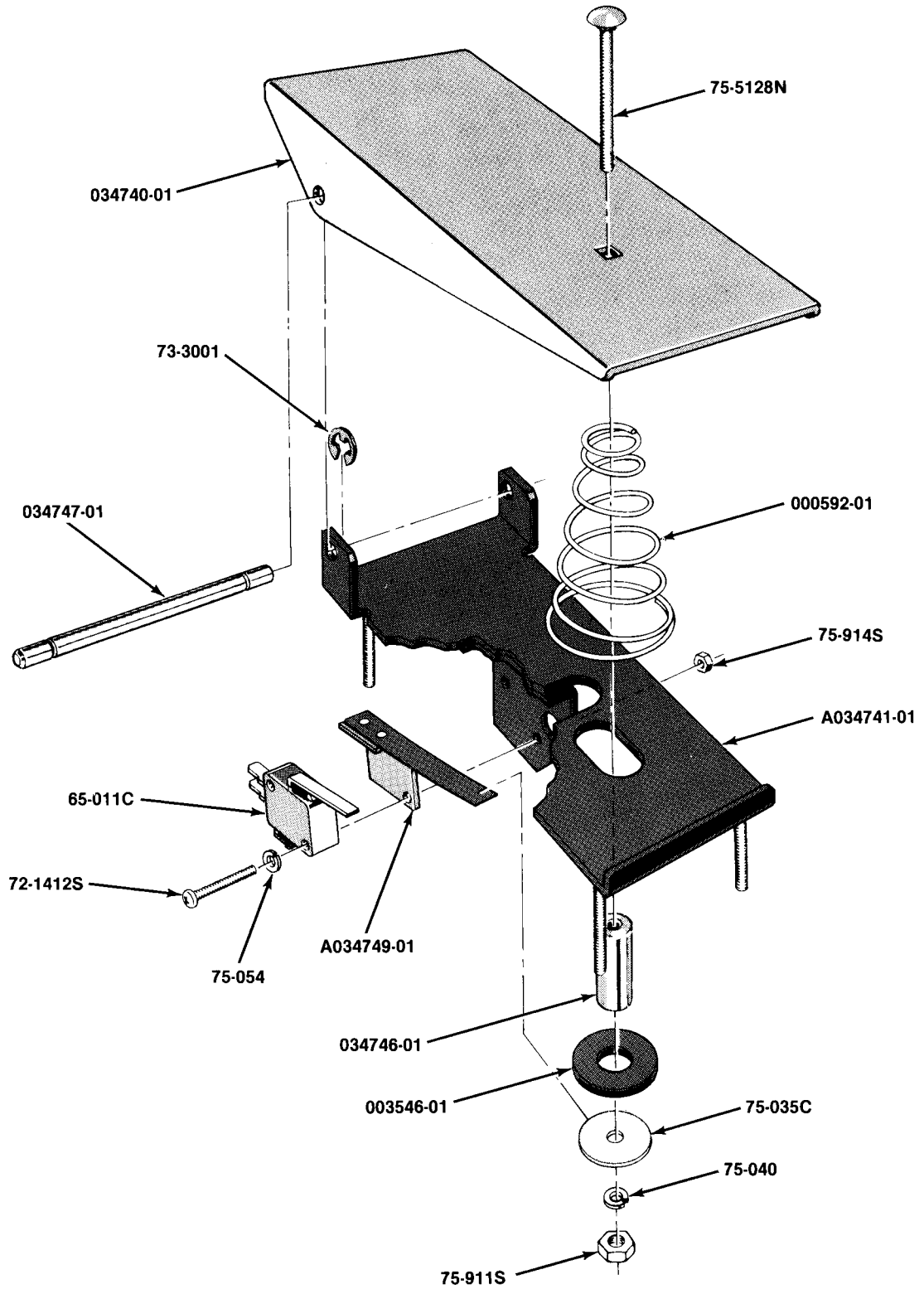


**Figure 26 Gear Shifter Assembly ("H" Pattern)**  
**A000608-03 S**

## Figure 26 Gear Shifter Assembly Parts List

<i>Part No.</i>	<i>Description</i>
A000610	Shifter Handle
65-021A	Single-Pole Single-Throw Low-Force Miniature Switch
73-7C0307S	Steel Flat Flange-Head Solid-Shank Rivet, 3/32"-Diameter Shank × 3/16"-Diameter Head × 7/16"-Long Shank
75-044	#4 Internal-Tooth Steel Split Lock Washer
75-046	#6 Internal-Tooth Steel Split Lock Washer
76-11375S	3/8" Diameter Bearing-Grade Steel Ball
78-16002	Dow Corning Silicone Compound #5
78-3002003	Spring
85-22F412	#4-40 × 3/4" Pan-Head Phillips Self-Threading Type F Steel Machine Screw
85-22F608	#6-32 × 1/2" Pan-Head Phillips Self-Threading Type F Steel Machine Screw
000609-01	Gear Shifter Housing ( <i>two of these required per gear shifter</i> )
000611	Shift Detent

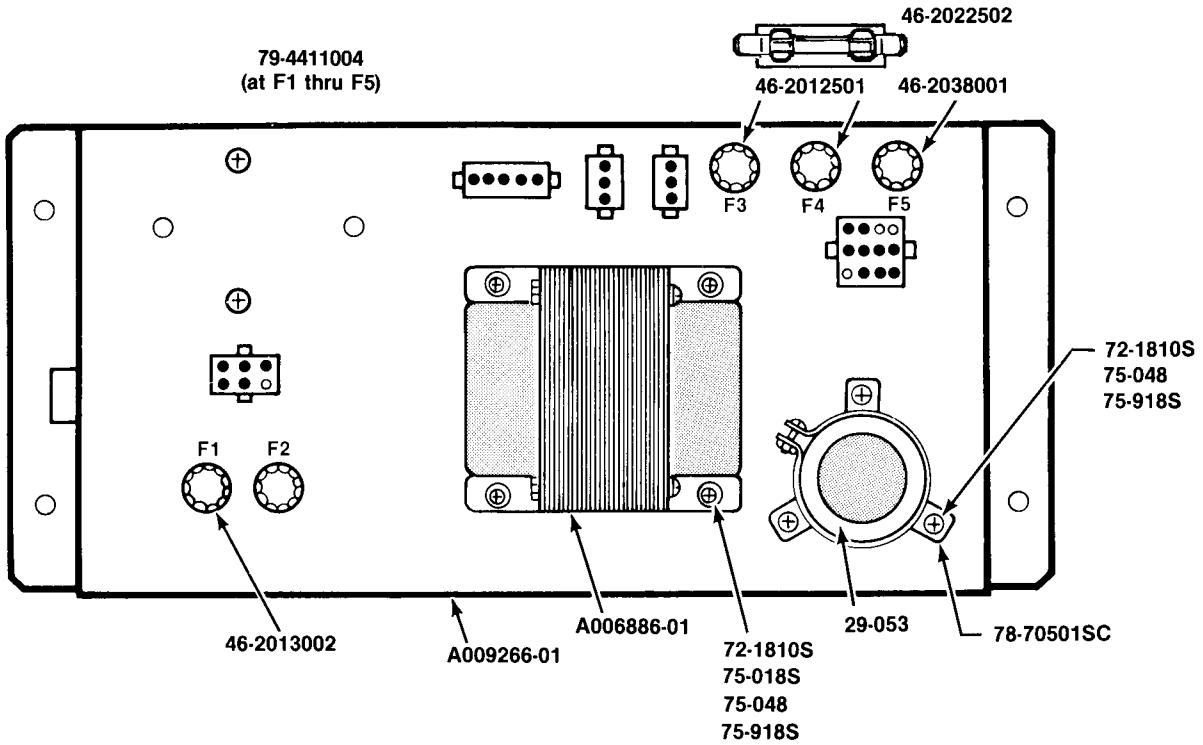
*Note: The "H"-pattern shift bezel (with the four numbers stamped on it) is not part of the gear shifter. It is shown instead in Figure 22, Control Panel Assembly.*



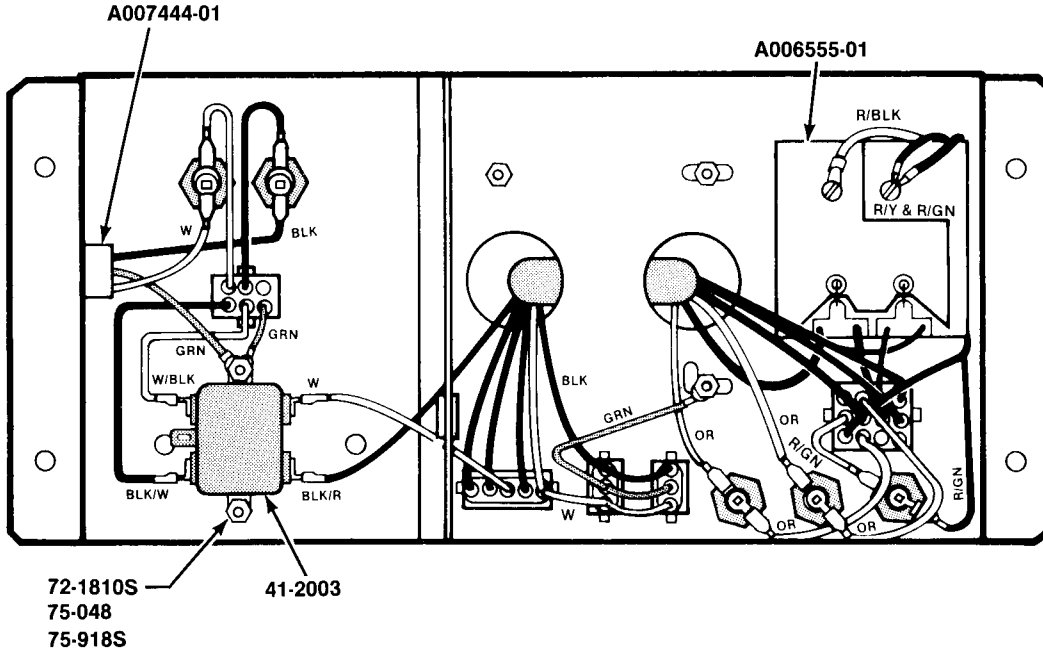
**Figure 27 Foot Pedal Control  
A034748-01 A**

## Figure 27 Foot Pedal Control Parts List

<i>Part No.</i>	<i>Description</i>
A034741-01	Foot Pedal Base with Bolts
A034749-01	"L" Bracket with Actuator Blade
65-011C	Single-Pole Double-Throw Low-Force Miniature Switch
72-1412S	#4-40 × ¾" Cross-Recessed Pan-Head Cadmium-Plated Steel Machine Screw
73-3001	Carbon Spring Steel External Retaining Ring, for ¼" shaft diameter
75-035C	#¼ Plain Flat Wide-Pattern Corrosion-Resistant Steel Washer
75-040	#10 Stainless-Steel Split Lock Washer
75-054	#4 Zinc-Plated Steel Internal-Tooth Lock Washer
75-5128N	#10-24 × 1¾" Round-Head Square-Neck Nickel-Plated Steel Carriage Bolt
75-911S	#10-24 Standard Hex-Pattern Cadmium-Plated Steel Machine Nut
75-914S	#4-40 Standard Hex-Pattern Cadmium-Plated Steel Machine Nut
78-1709	Dow Corning Molykote G-n Paste Lubricant
000592-01	Spring
003546-01	Rubber Stop
034740-01	Foot Pedal
034746-01	Metal Spacer
034747-01	Pivot Pin



**NOTE: Fuses F1, F2, and F6 are not part of this power supply assembly and must be purchased separately. They have been listed here for your convenience.**

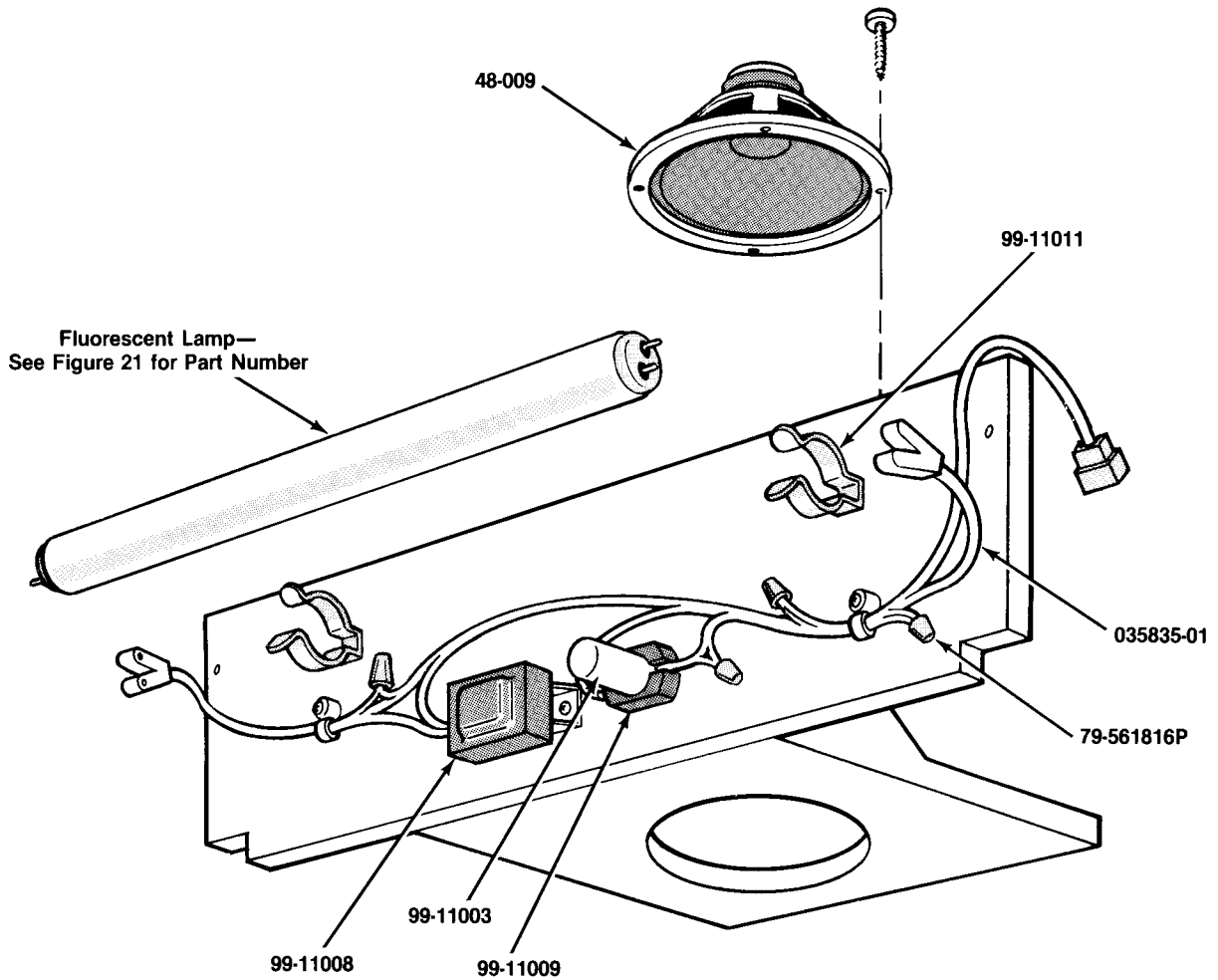


**Figure 28 Type B Power Supply Assembly  
A007197-01 K**

**Figure 28 Type B Power Supply Assembly**  
**A007197-01 K**  
**Parts List**

<i>Part No.</i>	<i>Description (Reference Designations in Bold)</i>
A006555-01	Rectifier P.C. Board Assembly
A006858-01	Voltage Selection Plug (95V—Black)
A006858-02	Voltage Selection Plug (110V—Orange)
A006858-03	Voltage Selection Plug (205V—Green)
A006858-04	Voltage Selection Plug (220V—Red)
A006886-01	Type B Transformer Termination Assembly
A007192-01	Power Switch Termination
A007444-01	Power-In Harness
A009266-01	Power Supply Base Assembly
29-053	26,000 uf 15V Electrolytic Capacitor
41-2003	5-Amp Power Line Filter
46-2012501	2½-Amp, 125-Volt Slow-Acting Type 3AG Fuse <b>(F3, F4)</b>
46-2013002	3-Amp, 250-Volt Slow-Acting Type 3AG Fuse <b>(F1*, F2*)</b>
46-2022502	2½-Amp, 250-Volt Slow-Acting Type 3AG Fuse <b>(F6*)</b>
46-2038001	8-Amp, 125-Volt Normal-Acting Type 3AG Fuse <b>(F5)</b>
72-1810S	#8-32 × 5/8" Cross-Recessed Pan-Head Cadmium-Plated Steel Machine Screw
75-018S	#8 Flat SAE-Standard Zinc-Plated Steel Washer
75-048	#8 Zinc-Plated Steel Split Lock Washer
75-918S	#8 Standard Cadmium-Plated Steel Machine Hex Nut
78-70501SC	2" Diameter Capacitor Mounting Bracket
79-4411004	Panel-Mounted Non-Indicating 3AG Cartridge-Type Fuse Post

*\*NOTE: Fuses F1, F2, and F6 are not part of this power supply assembly and must be purchased separately. They have been listed here for your convenience.*

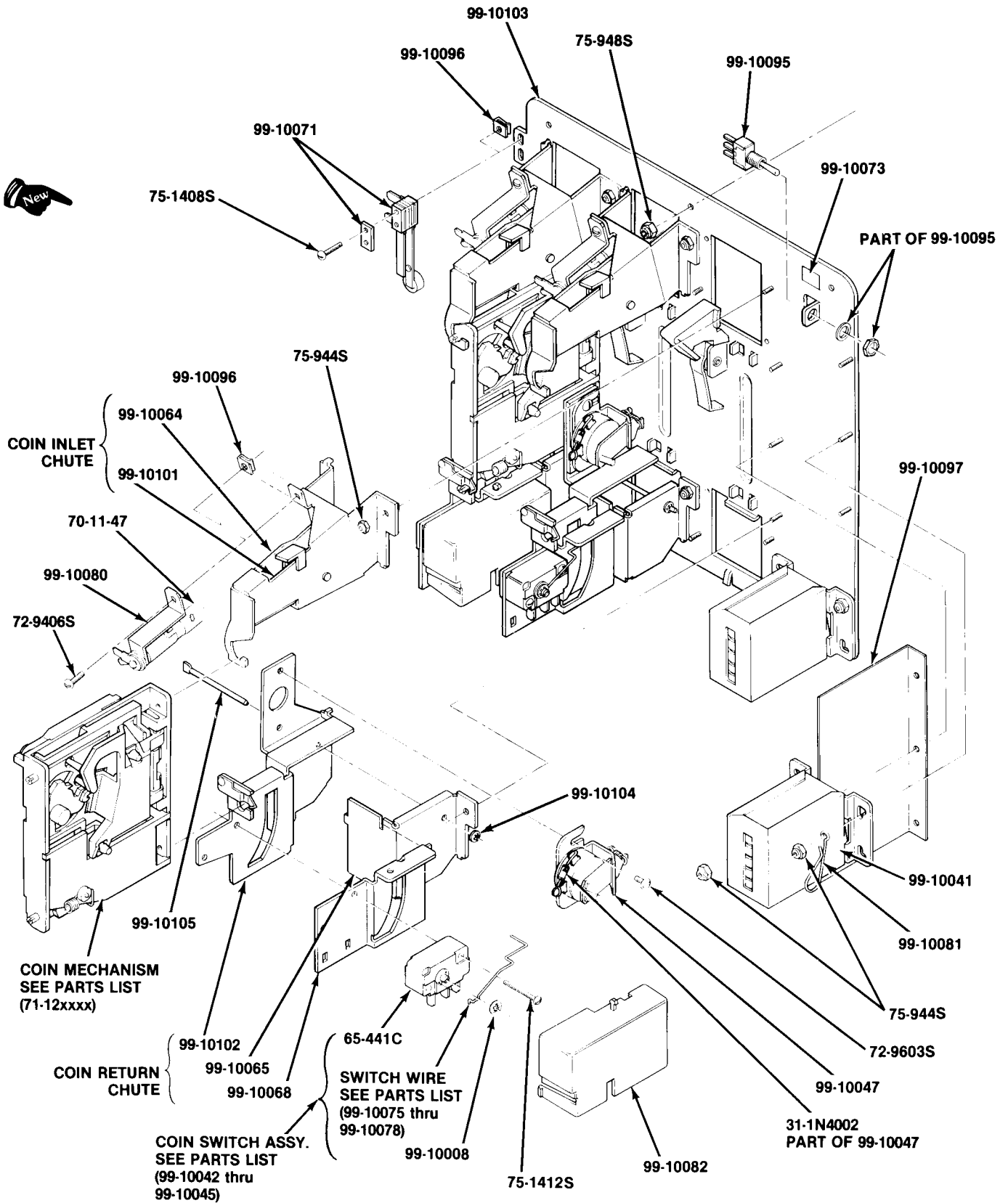


**Figure 29 Fluorescent Light and Speaker  
A035658-01 A**

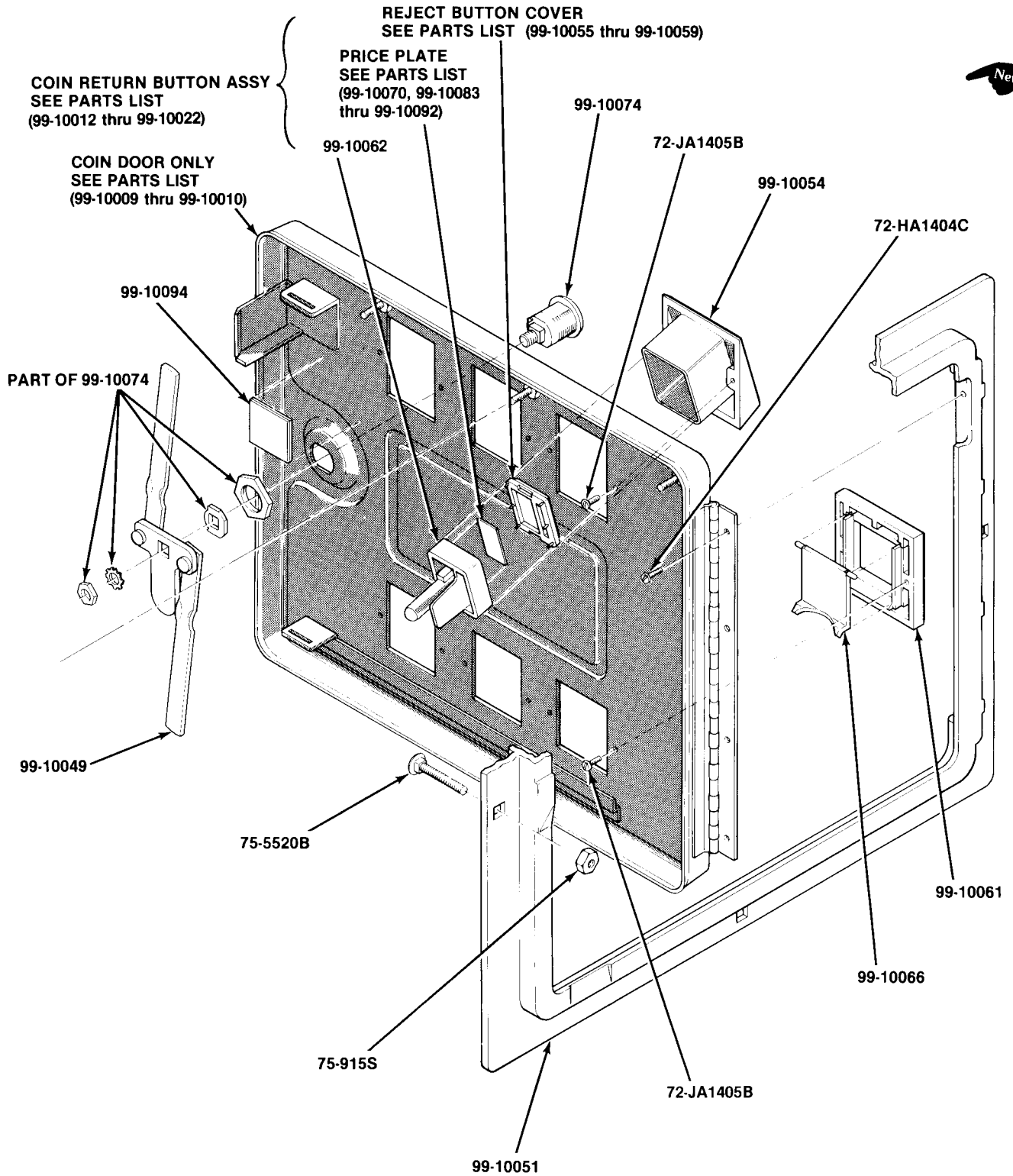
**Parts List**

<i>Part No.</i>	<i>Description</i>
48-009	8" 8-Ohm 8-Watt High-Fidelity Speaker
79-561816P	Wire Nut for 16- to 18-Guage Wires
99-11003	Fluorescent Lamp Starter
99-11008	Ballast Transformer
99-11009	Starter Socket
99-11011	1½" Clamp
035835-01	Y-Lead Connector





**Figure 30 New Coin Door  
71-10XXXX**



**Figure 30 New Coin Door  
71-10XXXX**



## Figure 30 New Coin Door, continued Parts List

<i>Part No.</i>	<i>Description</i>
31-1N4002	100V Silicon Rectifier 1N4002 Diode
65-441C	General-usage low-force miniature switch
70-11-47	Miniature bayonet-base incandescent lamp, type #47
71-1201ADU	U.S. \$1.00 coin mechanism
71-1201FCH	Swiss 1 Fr coin mechanism
71-1201MG	German 1 DM coin mechanism
71-1202MG	German 2 DM coin mechanism
71-1205FB	Belgian 5 Fr coin mechanism
71-1205MG	German 5 DM coin mechanism
71-1210PE	U.K. 10 P coin mechanism
71-1220CA	Australian 20¢ coin mechanism
71-1225CU	U.S. 25¢ coin mechanism
71-12100LI	Italian 100 Lire coin mechanism
71-12100YJ	Japanese Y100 coin mechanism
72-HA1404C	#4x1/4" Slotted pan-head thread-rolling tri-fluted "Taptite" cadmium-plated screw
72-JA1405B	#4x5/16" Slotted pan-head thread-rolling tri-fluted "Plastite" black screw
72-9406S	#4-40x3/8" Slotted truss-head steel machine screw
72-9603S	#6-32x3/16" Slotted truss-head steel machine screw
75-915S	#1/4-20 Standard pattern cadmium-plated steel hex nut
75-918S	#8-32 Standard pattern cadmium-plated steel hex nut
75-944S	#4-40 Polymer self-locking steel hex nut
75-948S	#8-32 Polymer self-locking steel hex nut
75-1408S	#4-40x1/2" Slotted pan-head steel machine screw
75-1412S	#4-40x3/4" Slotted pan-head steel machine screw
75-5520B	#1/4-20x1 1/4" Round-head square-neck steel bolt with black finish
99-10008	Switch wire retainer
99-10009	2-Mech coin door only
99-10010	3-Mech coin door only
99-10011	Inner panel
99-10012	U.S. 25¢ coin return button assembly
99-10013	U.S. \$1.00 coin return button assembly
99-10014	German 1 DM coin return button assembly
99-10015	German 2 DM coin return button assembly
99-10016	German 5 DM coin return button assembly
99-10017	Belgian 5 Fr coin return button assembly
99-10018	Swiss 1 Fr coin return button assembly
99-10019	Japanese Y100 coin return button assembly
99-10020	U.K. 10 P coin return button assembly
99-10021	Australian 20¢ coin return button assembly
99-10022	Italian 100 Lire coin return button assembly
99-10040	Coin inlet chute assembly
99-10041	Coin counter assembly
99-10042	Coin switch assembly for U.S. 25¢ and Belgian 5 Fr coins (silver wire)
99-10043	Coin switch assembly for German 1 DM, Swiss 1 Fr, and Japanese Y100 coins (black wire)
99-10044	Coin switch assembly for U.S. \$1.00, German 2 DM, and Italian 100 Lire coins (gold wire)

## Figure 30 New Coin Door, continued Parts List

<i>Part No.</i>	<i>Description (Reference Designations and Locations in Bold)</i>
99-10045	Coin switch assembly for German 5 DM, U.K. 10 P, and Australian 20¢ coins (green wire)
99-10047	Lockout coil assembly
99-10048	Coin door harness assembly
99-10049	Locking arm assembly
99-10051	Coin door frame
99-10054	Coin button housing
99-10055	Coin return button cover for Japanese Y100 coin
99-10056	Coin return button cover for German 1 DM and Swiss 1 Fr coins
99-10057	Coin return button cover for U.S. 25¢ and Belgian 5 Fr coins
99-10058	Coin return button cover for U.S. \$1.00, German 2 DM, and Italian 100 Lire coins
99-10059	Coin return button cover for German 5 DM, U.K. 10 P, and Australian 20¢ coins
99-10061	Coin return bezel
99-10062	Coin return button
99-10063	Right half of coin inlet chute
99-10064	Left half of coin inlet chute
99-10065	Coin return box
99-10066	Coin return cover
99-10070	U.S. 25¢ price plate
99-10071	Slam switch assembly
99-10073	Test switch decal
99-10074	Lock assembly
99-10075	Black switch wire—for German 1DM, Swiss 1Fr and Japanese Y100 coins
99-10076	Silver switch wire—for U.S. 25¢ and Belgian 5Fr coins
99-10077	Gold switch wire—for U.S. \$1.00, German 2DM and Italian 100 Lire coins
99-10078	Green switch wire—for German 5DM, U.K. 10P and Australian 20¢ coins
99-10080	Miniature bayonet-base lamp socket
99-10081	Wire key holder
99-10082	Switch cover
99-10083	U.S. \$1.00 price plate
99-10084	German 1 DM price plate
99-10085	German 2 DM price plate
99-10086	German 5 DM price plate
99-10087	Belgian 5 Fr price plate
99-10088	Swiss 1 Fr price plate
99-10089	Japanese Y100 price plate
99-10090	U.K. 10 P price plate
99-10091	Australian 20¢ price plate
99-10092	Italian 100 Lire price plate
99-10094	Fish paper insulation
99-10095	Toggle switch
99-10096	“U”-type fastener
99-10097	Fish paper insulation
99-10101	Coin inlet chute sub-assembly
99-10102	Switch and lockout coil bracket sub-assembly
99-10103	Inner panel with levers sub-assembly
99-10104	Anti-penny-flip bar retainer
99-10105	Anti-penny-flip bar