

7-101-00

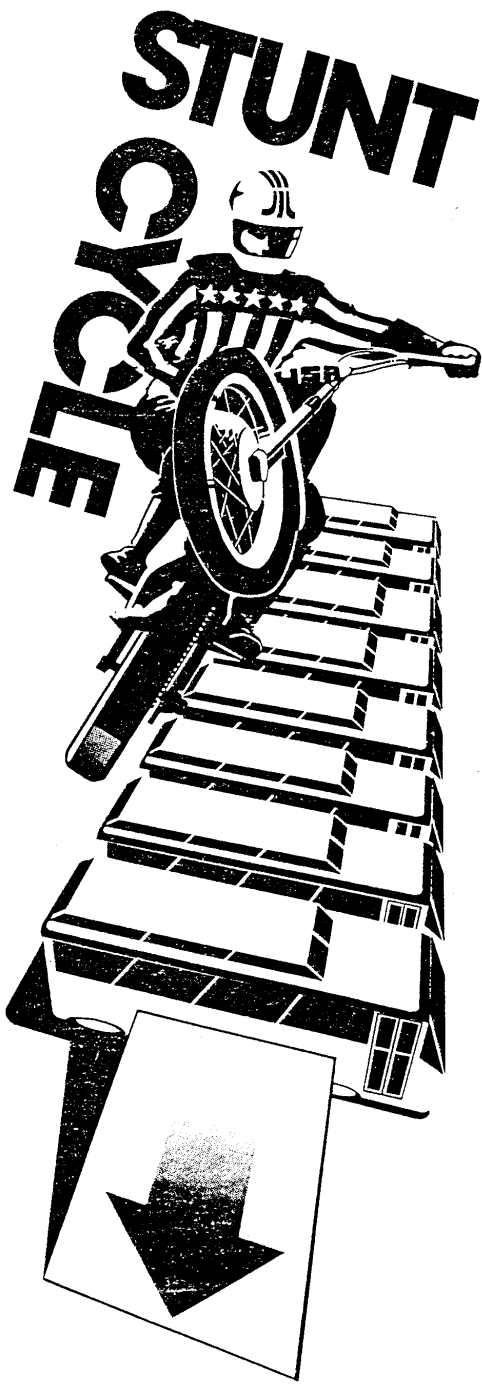

OPERATION  
MAINTENANCE  
SERVICE  
MANUAL



ATARI INC. 14600 WINCHESTER BLVD, LOS GATOS, CA 95030 • (408) 374-2440 • TELEX 357-488

Copyright © 1976 by Atari, Inc.

# TABLE OF CONTENTS

<i>Subject</i>	<i>Page</i>		
I. INTRODUCTION		IV. INSTALLATION INSTRUCTIONS	
1.1 Physical Description of Game	1	4.1 Unpacking Instructions	15
1.2 Brief Description of Play	1	4.1.1 Examination for Shipping Damage	15
II. SPECIFICATIONS		4.1.2 Mechanical Inspection	15
2.1 General	3	4.2 Energizing the Game	15
2.2 Electrical	3	4.2.1 Application of AC Power	15
2.3 Environmental	3	4.2.2 Check on Operation of Interlock Switch	15
2.4 Owner/Operator Options for Structuring of Play	3	4.3 Game Structuring	15
2.5 Accessories Available on Separate Order	3	4.3.1 Adjustment of Credits-Per-Coin Option	16
III. THEORY OF OPERATION		4.3.2 Adjustment of Free-Game Option	16
3.1 Major Functional Parts	5	4.3.3 Adjustment of Free-Game-Control Option	16
3.2 General Information	5	4.3.4 Adjustment of Number-of-Misses Option	16
3.2.1 Energizing the Game	5	V. MAINTENANCE AND ADJUSTMENTS	
3.2.2 TV Monitor	5	5.1 Routine Maintenance	19
3.2.3 Picture on TV Screen	5	5.1.1 Cleaning	19
3.3 Game Sequence	5	5.1.2 Lubrication	19
3.3.1 Operating Modes	5	5.2 Adjustments on TV Monitor	19
3.3.2 Attract Mode	5	5.3 Adjustment of Speaker Volume	19
3.3.3 Play Mode	5	VI. TROUBLESHOOTING AND REPAIR	
3.3.4 Owner/Operator Options	5	6.1 General Procedure	21
3.4 Detailed Technical Description of Operation	8	6.1.1 Identifying the Trouble Area	21
3.4.1 General Information	8	6.1.2 Locating the Trouble Cause	21
3.4.2 Summary of Technical Features	8	6.1.3 Correcting the Trouble Cause	21
3.4.3 Horizontal Motion Control	8	6.1.4 Verifying Correct Game Operation	21
3.4.4 Vertical Motion Control	9	6.2 Test Equipment	22
3.4.5 Cycle Video Generation	9	6.2.1 Basic Test Equipment	22
3.4.6 Bus (Object) Video Generation	10	6.2.2 Optional Test Equipment	23
3.4.7 Score Counting	10	6.3 Specific Troubleshooting Information	23
3.4.8 Score Display	10	6.3.1 Antenna Static Modification	23
3.4.9 Ramp Generation	10	6.3.2 TV Monitor	23
3.4.10 Bus (Object) Zone	11	6.3.3 Coin Mechanism	24
3.4.11 Miss Counter	11	VII. SCHEMATICS, DRAWINGS AND PARTS LISTS	25
3.4.12 Direction Circuit	11		
3.4.13 Cycle Angle Control	11		
3.4.14 Flip Circuit	12		
3.4.15 Cycle Reset	12		
3.4.16 Good or Bad Jump	12		
3.4.17 Throttle Disable	12		
3.4.18 Return Throttle "Window"	12		
3.4.19 Roadway Circuit	12		
3.4.20 Video Generation	12		
3.4.21 Gravity Generator	13		
3.4.22 Power Supplies	13		
3.4.23 Sound Circuits	13		

# I. INTRODUCTION

## 1.1 PHYSICAL DESCRIPTION

Atari's "Stunt Cycle" is a motorcycle video action game designed for one or two players. The game is packaged in its own distinctively styled upright cabinet that rests directly on the floor. (Drawing number A004807 in Section VII of this manual shows an external view of the game.) A 19-inch black-and-white TV monitor is mounted at the top front of the cabinet and players stand in front, facing the TV screen.

A horizontal strip of transparent material is affixed to the picture tube. This strip covers the normally black area near the top of the screen. Its left half reads "Extended Play"; the right half reads "Return Hand Throttle to Idle". In addition, two other small transparent strips, one next to each score, read "Player 1" and "Player 2".

The player-operated controls are located on a horizontal flat panel, beneath the TV monitor. The controls consist of the one-player start and two-player start push buttons, plus a set of handlebars with a "throttle" on the right grip.

Two identical coin mechanisms are located below the player-operated controls. They accept quarters only, and are connected so that either one can initiate play. The Stunt Cycle game features an owner/operator-adjustable option that permits on-site game structuring for either one or two credits per coin. The cash box is located behind the coin mechanism access door. A speaker mounted inside the cabinet, to the left of the coin mechanism, will produce a variety of game sounds during play.

## 1.2 BRIEF DESCRIPTION OF PLAY

In the Stunt Cycle game, a player tries to jump as many buses as possible. Each successful jump increases the row by one bus. After an operator-selected number of buses is reached, the player receives a free game and continues jumping, as long as no more than a pre-set number of crashes occur. There is no game timer: the game ends when the player tries to jump a given set of buses and is unsuccessful after a pre-set number of attempts.

A player must "rev up" to the proper speed by the time he or she has reached the take-off ramp: too slow a speed will cause the stunt cyclist to descend too early and crash. Too fast a speed will also cause the cyclist to crash (see next paragraph). For an illustration of the game in progress, see Figure 1-1.

Regardless of the number of buses to be jumped, the game always has the same degree of difficulty. There is a certain zone beyond the landing ramp within which one must land. Should the player be going too fast over the buses and land beyond this safe-landing zone, the jump is considered a crash.

In addition to proper speeds required for jumping the buses, one must not accelerate too much on the two approach tracks (the two uppermost black lines on the monitor). Doing so will cause the player's cycle to do "wheelies"; in extreme cases the bike will flip over backwards, which counts the same as a crash while jumping. However, driving too slowly in this stretch will not impair the player's score. The scoring is simple: one point is gained for each successful jump.

Along with the video action just described, the following sounds produced by the speaker during play add to the game's excitement:

Upon acceleration, the motor sound increases in pitch. Doing "wheelies" at controlled speeds without flipping produces no special sound other than the regular motor sound. Doing "wheelies" and flipping over backwards, however, produces a screeching sound.

Performing a successful jump produces a crowd cheer sound. And finally, performing an unsuccessful jump and landing on a bus produces a twang with each bounce; then a crash sound is made as the stunt cyclist lands on the ground beyond the ramp.

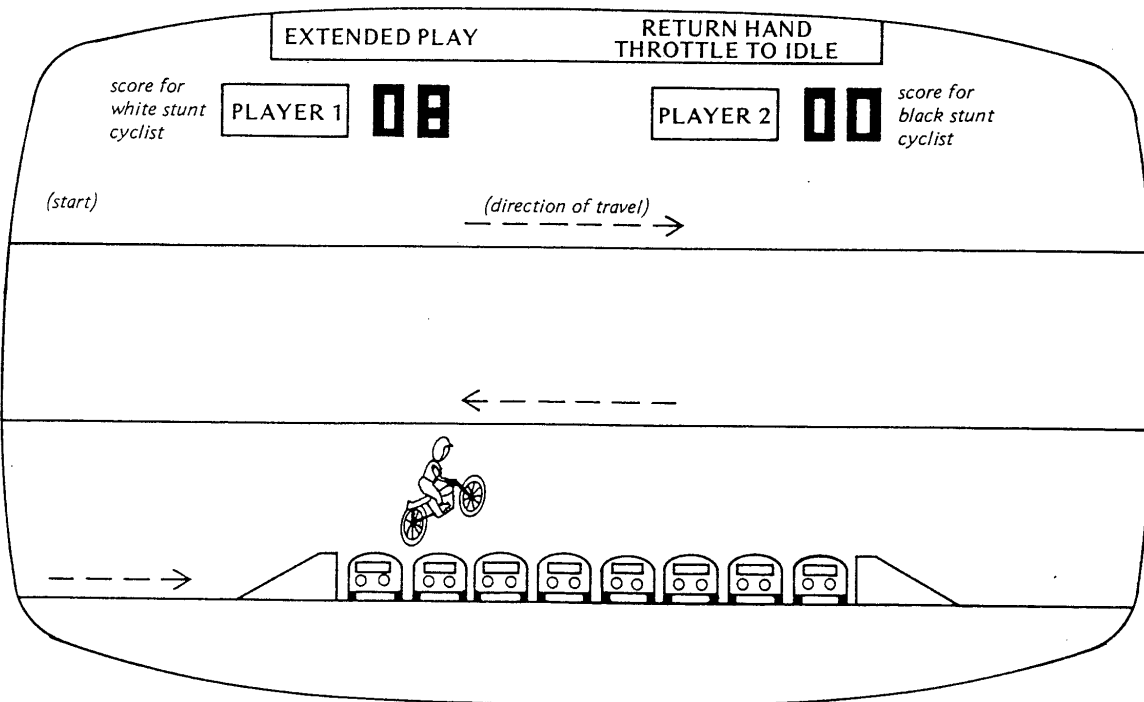

Figure 1-1 Typical Picture Partway Through a Stunt-Cycle Jump

## II. SPECIFICATIONS

---

3

### 2.1 GENERAL

Cabinet Dimensions:	Height 65 inches, Width 25¼ inches, Depth 26½ inches
TV Monitor:	Motorola Model XM501, black and white, with 19-inch screen
Coin Mechanisms:	Two identical mechanisms (connected in parallel); accept quarters only
Cash Box:	Removable, located behind locked access door to coin mechanism assembly
Power Cord:	Approximately 6 ft. long, extending from rear of cabinet and having grounded three-prong plug for conventional wall outlets

### 2.2 ELECTRICAL

Power Requirement:	Uses conventional wall outlet providing 60-cycle AC (60-Hz, single-phase) at 110 volts; power consumption rated at 175 watts
Fusing:	All fuses located inside cabinet; TV monitor has two 1-amp. fuses and remainder of game is protected by one 2-amp. slow-blow fuse
Power Interrupt Switch:	This is a safety switch located inside the cabinet. It causes the AC power to the game to be interrupted whenever the rear service access door is unlocked and opened.

### 2.3 ENVIRONMENTAL

Operating and Storage Temperature Range:	From 32°F to 120°F (ambient temperature)
Relative Humidity:	From 0% to 80% without condensation

### 2.4 OWNER/OPERATOR OPTIONS FOR STRUCTURING OF PLAY

- Choice of 1 or 2 credits per quarter
- From 1 to 7 unsuccessful jumping attempts possible before player's game ends
- From 12 to 27 successful jumps required before free game is given
- Choice of free game or not
- Variable speaker volume

### 2.5 ACCESSORIES AVAILABLE ON SEPARATE ORDER

Video Probe:	Order from Atari, Inc.
Universal Test Fixture for Stunt Cycle Game:	Order from Atari, Inc., catalog no. TF101

# III. THEORY OF OPERATION

## 3.1 MAJOR FUNCTIONAL PARTS

The simplified block diagram in Figure 3-1 shows the major functional parts of the Stunt Cycle game and how they are interconnected. Note that the speaker is separate from the TV monitor.

## 3.2 GENERAL INFORMATION

The general information about the Stunt Cycle game given in this paragraph provides a background for understanding the Installation Instructions in Section IV of this manual, and the description of game operation in paragraphs 3.3 and 3.4.

**3.2.1 ENERGIZING THE GAME:** The Stunt Cycle game does not have an external "power on" switch. Instead the game is energized as soon as the power cord is plugged into an active AC wall outlet. This outlet must provide the AC power listed in the Specifications (Section II of this manual).

**3.2.2 TV MONITOR:** The TV monitor is a self-contained transistorized television monitor supplied to Atari, Inc., by Motorola. Because the composite video signal supplied to the monitor by the game's electronic control circuitry differs in certain important respects from the signal derived from commercial TV broadcasts, the monitor does not produce any sound, and the picture appearing on its screen is unlike that of a home TV set. The game's sound is produced by a speaker mounted separately from the monitor and driven directly by the game's electronic control circuitry. (The separate "audio" and composite video connections shown in Figure 3-1 point out this difference.)

**3.2.3 PICTURE ON TV SCREEN:** The game's composite video is constructed to produce three video levels (gray, black, and white). The horizontal "scan lines" on the game TV screen will be more noticeable than those on a home TV set. This is explained by the fact that the composite video contains synchronization information that causes the TV monitor to produce only 260 horizontal scans, without interlace, from top to bottom of the screen, rather than the home TV's 525 lines with interlace.

The game's TV screen is divided into three horizontal approach tracks, with the buses to be jumped on the bottom track, as shown in Figure 1-1. The stunt cyclist image is either black or white video level, depending on which player's turn is up, and the background is a gray video level.

The words "Player 1" and "Player 2" are silk-screened on the acetate overlays placed on the TV screen. Rectangular-shaped "windows" of white video level provide backlighting to identify which player is presently using the motorcycle.

In addition, the words "Extended Play" and "Return Hand Throttle to Idle" are silk-screened on acetate overlays

placed at the topmost edge of the TV screen. A long rectangular "window" of white video level provides separate backlighting to each of these halves, to indicate a free game was acquired and to inform the player that the throttle must be returned before starting each run, respectively.

## 3.3 GAME SEQUENCE

**3.3.1 OPERATING MODES:** During use, the Stunt Cycle game can be described as operating in either of two modes, attract or play. Plugging the power cord into an active AC outlet energizes the game and it starts out in the attract mode. It remains in this mode until a player deposits a coin and the coin clears the coin mechanism and a start button is pushed at which point signals derived from the mechanism and the start switch cause the game to go into the play mode. The game remains in this mode until the stunt-cycle competition ends (by either a cyclist crashing too many times over the buses or flipping over backwards while doing "wheelies" too many times or a combination of both). At this point the game reverts back to the attract mode.

**3.3.2 ATTRACT MODE:** During the attract mode, the stunt cyclist moves over the approach tracks and jumps a given distance. (A crash may or may not occur, depending on the number of buses.) The cyclist continuously repeats this series of actions. This pattern appears both after the game is energized and after completion of a play mode.

During the attract mode, none of the push button switches on the player control panel are lighted, depressing either start push button produces no response from the game, actuating the handbar throttle produces no variation in the cyclist's speed, and no sound is produced by the speaker. The winning score in a two-player game will not be blinking as in other Atari games: a quick comparison of the two scores shows who is the winner.

**3.3.3 PLAY MODE:** A player causes the game to change over from the attract to the play mode when depositing a coin that clears the coin mechanism and pushing a start button. Signals from the coin mechanism and start switch go to the electronic control circuitry and produce the following responses:

Game set for 1 credit/coin:

- (a) ONE PLAYER START button lights up; if two coins were inserted, both this and the TWO PLAYER START button light up.
- (b) Cyclist continues as in the attract mode.

Game set for 2 credits/coin:

- (a) Both start push buttons light up.
- (b) Cyclist continues as in the attract mode.

To continue the game sequence, a player must next depress the appropriate start push button. One may only

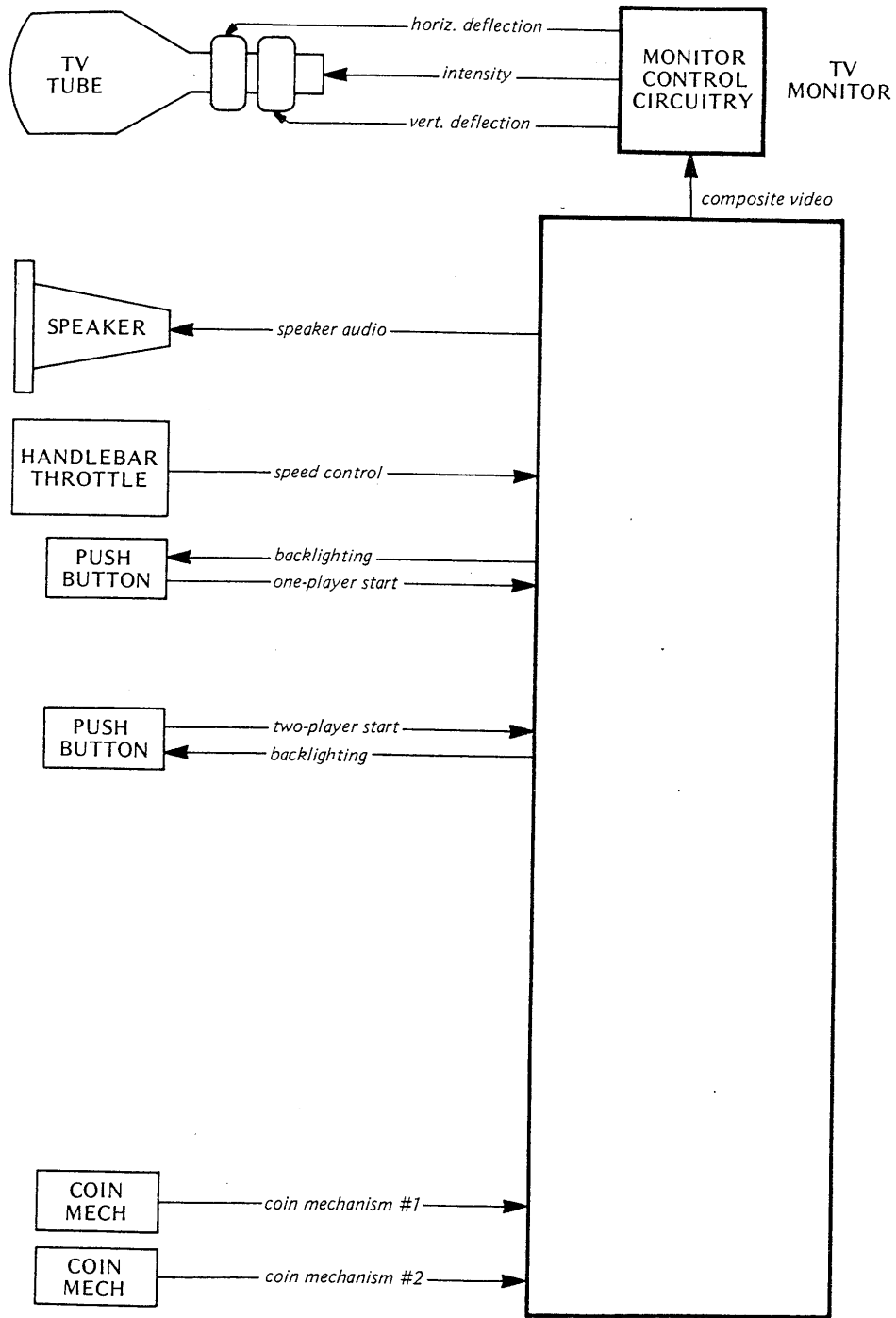

FRONT PANEL Figure 3-1 Block Diagram of Stunt Cycle Game

press a lighted button; depressing an unlighted one has no effect on the game. A signal from the start switch goes to the electronic control circuitry and produces the following responses:

Game set for 1 credit/coin:

- (a) Cyclist is reset to starting point and slowly moves forward to the right at idle speed.
- (b) Motor sound hums at a low level.
- (c) Handlebar throttle (right-hand part of the handlebar only) becomes functional.
- (d) With one coin deposited: one game for one player only.  
With two coins deposited: two games for one player or one game for two players, depending on which start button was pushed.\*

Game set for 2 credits/coin:

- (a) Cyclist is reset to starting point and slowly moves forward to the right at idle speed.
- (b) Motor sound hums at a low level.
- (c) Handlebar throttle becomes functional.
- (d) With each coin deposited, the following is granted: either two games for one player or one game for two players, depending on which start button was pushed.

At this point, the (first) player may begin the game by turning the throttle control towards the body or counter-clockwise, as seen from the side. This increases the speed of the stunt cyclist image as it advances towards the right, in addition to raising the pitch of the motor sound. A spring inside the grip automatically returns it to the idle position, if released. After running off the right edge of the TV screen, the image "turns around" and reappears at the right edge of the middle approach track, heading towards the left. The opposite happens as the image reaches the left edge of this track and wraps around to the bottom track.

If the player applies slightly excessive throttle, the cyclist image will stand on its rear wheel (doing "wheelies"). This is accompanied by the normal motor sound. However, when very excessive throttle is applied, the image will flip over its back, continue down the track for short stretch in this mode, and be accompanied by a screeching sound. Then the image automatically returns to the starting position and resumes its approach once more. Such a move is counted just as a crash onto or beyond the buses would be.

Next, the cyclist image attempts jumping the buses. Running up the takeoff ramp, its momentum is determined by its previous speed. If the proper speed had been achieved prior to takeoff, then the stunt cyclist will land in an area

\*Note that with one player, the stunt cyclist image will be white video level. In the case of the two-player game, the second cyclist image will be black video level.

extending about 3/4 inch beyond the landing ramp. This successful jump will be accompanied by a crowd cheer sound from the speaker. Thereafter the cyclist returns to the start position, and one bus will be added to the right of the last bus. That player's score is also increased by one point.

Lastly, the cyclist may not have gained enough momentum by the time the takeoff ramp was reached. This could be due to either too slow a speed over all the approach tracks, or else deciding too late that acceleration was necessary. In either case, the cyclist will take off and descend too early, landing on the buses. With each bounce onto the buses, a twanging sound is produced by the speaker. Then a final crash into the "safe landing" zone produces a repeated crashing sound. The cyclist image returns to the start position to attempt the jump again.

The owner/operator can set the Stunt Cycle game for a limit of one through seven attempts, inclusive. Thus, if the game were set to four attempts maximum, then that player's game would end when four unsuccessful tries were made. See Section 4.3 of this manual on how to perform this adjustment. In essence, the player determines the end of his or her own game by how skilled the player is. There is no game timer that ends play after a predetermined number of seconds.

If you watch the game carefully, you will notice that the headlights on all buses flash on and off. This blinking is synchronized with the spinning of the motorcycle wheels, and both create added realism.

Each player's turn comes up (in a two-player game) when one jump is missed. However, the above-mentioned rule still holds whereby games end after a certain number of unsuccessful jumps or spills while doing "wheelies". When the second player's turn comes up, the cyclist image turns from white to black, the backlighting behind PLAYER 1 disappears, and it appears behind PLAYER 2.

The owner/operator may also decide whether to grant a free game. A switch on the printed circuit board provides the means for regulating this option. See Section 4.3 on how to perform this adjustment. Free play is defined as credit for another game after a predetermined point score has been reached; see the paragraph below. If no free game is permitted, then the game ends when the player misses a jump the preset number of times.

If a free game has been allowed via this switch, then the owner/operator must decide at what score value such free play should occur. This option is also adjusted on the printed circuit board (see Section 4.3 for details) and is available from 12 to 27 buses, inclusive. For instance, if the PCB switch has been set for 15 points or buses, then a player must first successfully jump 15 buses before receiving credit for another game.

At this point, one is able to start a new game jumping buses, provided no more than the maximum allowable



crashes have previously occurred. In addition, at this point the backlighting will illuminate the "window" behind the EXTENDED PLAY half of the long horizontal rectangle. The number of buses will not be increased after 27, resulting in a maximum possible score of 27. However one can still continue jumping 27 buses forever, if no more than the preset number of crashes occur. The minimum possible score, incidentally, is 8 because the game begins with eight buses lined up.

**3.3.4 OWNER/OPERATOR OPTIONS:** The Stunt Cycle game has four option features that allow the owner/operator to alter game structuring. These options are as follows:

The two-position Credits-Per-Coin Switch mounted on the printed circuit board will structure the game for one credit per coin when in its "1P" position, and for two credits per coin when in its "2P" position. Paragraph 4.3.1 of this manual gives the procedure for adjusting this switch.

Another two-position switch, called S2, is mounted on the printed circuit board. It will structure the game for permitting or prohibiting free games. When in its "FG" position, it will allow free play; in its "FG" position it prohibits free games. Paragraph 4.3.2 gives further details for adjusting this switch.

The right-hand hexadecimal (sixteen-position) dip switch mounted in position F-7 on the printed circuit board will structure the game to grant a free game at a given point value. Paragraph 4.3.3 gives a detailed illustration of this switch, plus a chart linking the various point values to their proper switch settings.

The final option, the left-hand hexadecimal dip switch, is also mounted on the printed circuit board in position F-5 and will structure the game to end after a given number of crashes. Paragraph 4.3.4 again gives a detailed illustration of this switch, plus another chart linking the various number of misses to their proper switch settings.

### 3.4 DETAILED TECHNICAL DESCRIPTION OF OPERATION

**3.4.1 GENERAL INFORMATION:** This subsection gives a technical description of the game's electronic circuitry. Drawing number 004128 is a three-sheet schematic diagram of the circuitry on the printed circuit board, and drawing number A004128 is the PCB assembly drawing showing the locations of the components called out on the schematic. The position of each integrated circuit device is identified by a column letter designation (A through N), and by a row number designation (1 through 9). Drawing number 004772 is a schematic of the harness wiring inside the game cabinet. These drawings and a schematic diagram of the TV monitor's circuitry are included in Section VII of this manual.

On the PCB schematic the symbol *P* (appearing at various inputs to logic gates and other integrated circuits) indicates a connection to +5 volts through a pull-up resistor.

In the subsections that follow, the portions of the circuitry being described can be located on the PCB schematic by finding the intersection of the zone letters (A, B, C or D) and the zone numbers (1 through 8). For example, the designation *Sheet 1, Zone A 8* refers to the extreme lower left corner of sheet 1 of the schematic.

### 3.4.2 SUMMARY OF TECHNICAL FEATURES:

- Oscillator -- H.F. Clock: Typical of other games; frequency, 14.318 MHz
- Clock: Oscillator divided by 2
- Horizontal Sync Counter: Synchronous; divides clock frequency by 457
- Vertical Sync Counter: Asynchronous; divides horizontal sync frequency by 260
- Horizontal Sync Pulse: Flip-flop circuit set by horizontal reset and reset by 32H; pulse width, 4.6  $\mu$ sec
- Vertical Sync Pulse: Flip-flop circuit set by vertical reset and reset by 8V; pulse width, 0.5 msec
- Comp sync: Combination of horizontal and vertical sync
- Horizontal Motion Counter: Synchronous; divides H.F. clock by 914 $\pm$ 1; counts  $\pm$ 1, depending on horizontal motion control
- Vertical Motion Counter: Synchronous; counts 248 horizontal sync pulses per frame; counting is disabled for 12 horizontal sync pulses per frame; counts  $\pm$ 7, depending on vertical motion control

**NOTE:** The Atari motion circuit is protected by U.S. patent no. 3,793,483.

**3.4.3 HORIZONTAL MOTION CONTROL (SHEET 3, ZONES C & D6):** The position of the throttle pot sets up the voltage level to which the 22- $\mu$ f capacitor will eventually charge or discharge. The effective resistance that the cap charges through depends on the status of the two analog switches. If the switches are both on, then the effective resistance is derived from the parallel combination of the 120K, 150K, and 68K resistors. If both switches are off, the effective resistance is 120K. The voltage level at the 22- $\mu$ f cap goes to the base of the emitter follower circuit (Q15).

The 2N3644 transistor and the 3.9K, 100K, and 150K resistors make up the variable current source. The amount of current supplied is directly proportional to emitter voltage of Q15. This variable current source supplies current to the speed pulses oscillator. As the current supplied increases, so does the frequency of oscillation increase. The current that flows through the 1N914 diode and 47K resistor sets the minimum speed.

When the cycle is in the stop mode, N5 pin 11 is high. This causes pin 5 of the speed pulse oscillator to increase to +5 volts. This disables the current coming in to pin 6 of the speed pulse oscillator, and oscillation stops. The rising edge of each speed pulse clocks the flip-flop at C2. This changes the data being loaded into the horizontal motion counter, causing the cycle position to move one count to the left or right.

**3.4.4 VERTICAL MOTION CONTROL (SHEET 1, ZONES D3 & D4):** The motion control is performed by up/down counter L8. The control data is in signals AV, BV, CV, and DV. When the counter is reset, the control data is a binary 8. This is a vertical stop code. When the control data is greater than 8, vertical motion goes up. When the control data is less than 8, vertical motion goes down.

When the cycle comes in coincidence with the fixed ramp, the LOAD signal becomes active. This loads the parallel data into the up/down counter, causing the control data to be greater than 8, and thus causing upward cycle movement.

The counter now begins to count down at the rate of gravity. When the control data counts down to 8, upward motion stops, and as control data continues to count down, the cycle moves downward until it comes in coincidence with the track, causing the counter to reset and yielding a vertical stop code.

If the jump is not far enough, then the cycle comes in coincidence with the object (bus) zone before it meets the track. This causes a bus hit or crash, which in turn causes the LOAD signal to become active. Such a crash loads the up/down counter, causing cycle motion to go upward and giving the appearance of bouncing back up from the buses. This type of motion is the same as jump motion, except that the cycle doesn't bounce off the buses as high as when it jumps them.

What controls the bounce is parallel data being loaded into the counter. The data that is present is dependent on the fixed ramp zone. When the LOAD signal goes active inside the fixed ramp zone, it loads in data for the upward motion to be higher. This is where the cycle first takes off from the fixed ramp. If LOAD goes active outside of the fixed ramp zone, then the data loaded into the counter will cause the upward motion to be less as in the case of bouncing off the buses.

After such a bounce, the cycle will land on the track and again reset the up/down counter -- yielding a vertical stop code. This reset function is supplied by the JUMP signal. The JUMP signal is the output of the RS flip-flop at gates N9 pins 3 and 11. The JUMP signal is set when the cycle comes in coincidence with the fixed ramp, and reset when the cycle meets the road. The cycle meeting the track is detected by flip-flop N7.

The only other type of vertical motion is when the cycle moves from one level of the approach track down to the next level. This is controlled by the dual flip-flop circuit at J2. This circuit will disable vertical motion counting for 32 horizontal lines every time the cycle direction changes. This causes the vertical cycle position to move down 32 lines from one track to the next.

**3.4.5 CYCLE VIDEO GENERATION (SHEET 1, ZONES A 1-4 AND B 1-4):** The cycle picture data is stored in the 4K ROM (82S115). The eight data outputs are loaded into shift registers E1 and E2. These registers are capable of shifting left or right. When the cycle is reset, so is the direction signal. This causes the registers to shift right and display a picture of the cycle pointing towards the right. When the direction signal switches, it causes the registers to shift left and display a mirror image of the cycle.

The different functions of the shift registers are controlled by the two select lines MS1 and MS2. When both select lines are high, the data is loaded into the registers. When MS1 is high and MS2 is low, the registers shift right. When MS2 is high and MS1 is low, the registers shift left.

In order for both select lines to go high and load the registers, the common input to these two gates B2 pins 3 and 11 must go low. This load pulse will occur three times during the display of the cycle. The horizontal position of these three pulses is a function of the horizontal motion window. The three pulses are generated by the two flip-flops and the gate A8 pin 13 following the horizontal window.

When the first of these three pulses occurs, the data for the first horizontal third of the cycle is loaded into the register. When the second pulse occurs, the middle third is loaded. When the third pulse occurs, the last third is loaded.

The address to the ROM will have to change in order to supply the correct data to the registers at each of these three pulses. Addresses A4 and A5 of the ROM are used for this function. If the direction signal is reset, then the gating network feeding these two addresses will yield the following: A4 = 0 and A5 = 0 on the first load pulse, A4 = 1 and A5 = 0 on the second load pulse, and A4 = 0 and A5 = 1 on the third load pulse.

If the direction signal is set, then the data at the third pulse becomes the data at the first pulse and vice versa. The four address lines A0, A1, A2, and A3 are controlled by the vertical motion counter. This selects the data for each individual line in the cycle picture. The status of address lines A6, A7 and A8 will determine which picture of the cycle will be selected in the ROM. There are eight different pictures of the cycle programmed into the ROM. These pictures show both wheels on the track, the cycle performing half-wheelies, full wheelies, and crash pictures.

**3.4.6 BUS (OBJECT) VIDEO GENERATION (SHEET 1, ZONES A 1-4 AND B 1-4):** The bus picture data is also in the 4K ROM. This data is accessed during the horizontal sync pulse and loaded into shift register F2. The output of this register is connected back into the serial input. This causes the object data to be recirculated through the register so that more than just one bus picture can be displayed. The serial picture information is clocked through by flip-flop D2, and is enabled by the bus zone signal.

The ROM is addressed in a fashion similar to cycle addressing. The four address lines A0-A3 again are used to select the data for each individual line in the bus picture. In the case of cycle addressing, these four addresses were controlled by the vertical motion counter. In the case of the bus addressing, these signals are controlled by the vertical sync counter. Multiplexer J1 selects between vertical sync signals or vertical motion signals. For cycle addressing, A4 and A5 were used to select each horizontal third of the cycle picture. The one possibility left for addresses A4 and A5 is to have both high. When A4 and A5 are both high, the bus picture data in the ROM is selected.

**3.4.7 SCORE COUNTING (SHEET 2, ZONES A 6-8 AND B 6-8):** Each time a good jump is performed, the score increments one count for the player who made the good jump. At the beginning of the game, both players start with an initial score of 8 and have eight buses to jump.

Score counting for the first player is performed by counter B8 and flip-flop A9 pin 9. Score counting for the second player is by means of counter B9 and flip-flop A9 pin 5. At the start of the game, the flip-flops are both reset and the counters are both loaded with a count of 8. The signal common to gates A8 pin 5 and B5 pin 4 determines which score will be incremented. When flip-flop C5 is in a set condition, it will enable the other input to each of these two gates, causing the output of the appropriate gate to clock its counter. This will increment the score by one.

Flip-flop C5 pin 11 is clocked at the end of each good jump. The data coming into the flip-flop is MAX. SCORE. The maximum score possible for either player is 27. When a player reaches a score of 27, this MAX. SCORE signal will prevent his or her score from counting any further.

**3.4.8 SCORE DISPLAY (SHEET 2, ZONES A 3-5 AND B 3-5):** The first player's score is displayed on the left side of the screen; the second player's score is on the right. The data A-F of the first player's score is multiplexed with data G-M of the second player's score by multiplexers B7 and A7. The output data is in the form of signals S1 - S6. During the upper half of the screen, the data A-F is selected on the left side and the data G-M is selected on the right. This selecting is done by the 256H signal. During the lower half of the screen, the data is selected by the player control signal. The upper and lower halves of the screen are selected by 128V.

From here the S1 - S6 signals are sent to another multi-

plexer. This multiplexer selects either S1 - S4 or S5 - S6. The data in signals S1 - S4 tell the value of the number in the ones digit, and data in signals S5 and S6 the value in the tens digit. These signals are selected by 16H.

This data is now transferred to a seven-segment decoder that will turn on the required segments for the given binary number (see Figure 3-2 below). The seven-segment decoder is enabled by the SCORE WINDOW signal. The random gating network that makes up the score window will yield the vertical position and the two horizontal positions of the score. The seven-segment decoder controls which segments are turned on or off. The actual position of each number segment is generated by the two 9312 decoders B6 and A6. The segment video information is then clocked out through flip-flop A5.

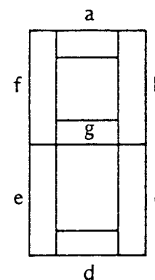

Figure 3-2 Seven-Segment Decoder Display

**3.4.9 RAMP GENERATION (SHEET 2, ZONES B 1-3):** There are two different ramps. The first one is called the fixed ramp, which is used for takeoff during a jump. The second ramp is called the movable ramp. Each time another bus is added for the player to jump, this ramp will move out to the next position to allow room for adding one more bus.

The vertical position of both ramps is controlled by the V RAMP signal. This signal is created by random gating to produce the required vertical location. The horizontal location of the fixed ramp is also produced by random gating. The horizontal location of the movable ramp is variable and depends on the score count.

The score count is introduced to the circuit in the form of signals S1 - S5 (mentioned earlier in paragraph 3.4.8 of this manual). These signals address the score translator ROM D7. This memory takes the decade-counting scheme of the score and translates it into a binary-counting scheme to be used for comparison with the horizontal sync counts. This memory also performs the decoding of the MAX. SCORE signal (mentioned earlier in paragraph 3.4.7). The data coming from this ROM is also used to determine when a free game is achieved.

The number of buses that have to be jumped successfully in order to win a free game is selected by means of a hexadecimal dip switch. The binary code from this switch is

compared to the binary code of the ROM outputs. When the two codes are equal, FREE GAME becomes active. The horizontal position of the movable ramp is determined in a similar fashion.

When the binary code of the ROM outputs equals the binary code of the horizontal sync counts, the  $A = B$  output of comparator E6 becomes active. This data is then clocked through by flip-flop F6. The output of this flip-flop loads the movable ramp window counter, which causes the MOVABLE RAMP WINDOW signal to become active. This signal will remain active until the counter reaches terminal count, at which time the counter will be disabled until it is reloaded at the next comparison. The time required between loading the counter and the counter reaching its terminal count will set up the horizontal width of the movable ramp.

The physical shape of the ramps is created by the comparator circuit at location N2. The counter at N1 will be enabled to count either during the fixed or the movable ramp zone. The binary code of this counter will be compared to the binary code of the vertical sync counts. Where the two codes are equal will form a diagonal line. Where one code is greater in value than the other will yield the area above or below the diagonal line. This fills in the area within the ramp.

The fixed ramp points in the opposite direction from the movable one. This is the reason for having the four exclusive OR gates used to invert the vertical counter data and comparator output data. The output data is clocked through by flip-flop M1.

**3.4.10 BUS (OBJECT) ZONE (SHEET 2, ZONE C3):** The bus zone comes from flip-flop J7. This flip-flop is clocked at the end of the fixed ramp zone. When the V RAMP signal is high at the end of the fixed ramp zone, the data will be clocked in and the OBJECT ZONE signal will become active. It will remain so until the movable ramp resets the OBJECT ZONE flip-flop.

**3.4.11 MISS COUNTER (SHEET 2, ZONES A 6-8 AND B 6-8):** The number of misses allowed each game is switch-selectable from 0 to 7 misses. This is done by setting the switch F5 to the desired position. A chart is supplied on the schematic. See also the detailed instructions for changing the settings on this switch in paragraph 4.3.4 of this manual.

The data from the switch is loaded into the miss counter at the start of the game. This counter will then count down from the count that was loaded into it.

Each time that the  $\overline{BAD\ JUMP}$  signal or the  $\overline{FLIP}$  signal goes low, it will set the RS flip-flop at gates A3 pin 3 and C4 pin 6. This RS flip-flop will reset when CYCLE RESET goes low. The output of the flip-flop will then go high, clocking the D flip-flop at C5. The Q output of the D flip-flop will go low, causing the miss counter to count

down by one count or point. The output of the D flip-flop will then be set by the  $\overline{COMP\ SCORE}$  signal. This series of events occurs in the two-player mode each time there is a miss.

In the one-player mode, the miss counter has to clock twice each time in order to yield the same number of misses as in the two-player mode. In order to accomplish this, the first output of the miss counter is fed back to enable V RESET to reset the D flip-flop C5 pin 1, causing the miss counter to be clocked an extra time. When the miss counter counts down to zero and borrows, this will cause the  $\overline{END\ GAME}$  signal to become active.

**3.4.12 DIRECTION CIRCUIT (SHEET 1, ZONES D4 AND D5):** The two flip-flops at N4 and M3 and the NAND gate at N5 pin 6 make up the direction circuit. Each time the cycle reaches the end of the track, it should reverse its direction. When the horizontal sync pulse is high during the rising edge of H WINDOW, the Q output of the first flip-flop will go high and  $\overline{Q}$  will go low. The  $\overline{Q}$  output is fed back into the set input. This causes the flip-flop to remain in the set condition until the horizontal window comes in coincidence with the fixed ramp zone, causing the flip-flop to reset. When the Q output of the first flip-flop went high, it clocked the second flip-flop, causing the direction to change states.

**3.4.13 CYCLE ANGLE CONTROL (SHEET 3, ZONES C 4-6 AND D 4-6):** This is actually a function of ROM addressing to select the different cycle pictures (mentioned earlier in paragraph 3.4.5). The signals used to select the pictures are R2 and R3. When these are both 0 and 0, the cycle is in the position with both wheels on the road. When R2 and R3 are 1 and 0, the cycle has raised its front wheel slightly (half-wheelie). When R2 and R3 are 0 and 1, the front wheel of the cycle is raised higher (full wheelie). When R2 and R3 are 1 and 1, the cycle is in the flipped position. These signals R2 and R3 are outputs from an up/down counter.

If the counter is reset to zero, it starts with the first picture. As the counter counts up, it rotates through the different angles of the cycle. The counter depends on the throttle for its upward or downward counting. If you apply a lot of throttle without having much momentum, you will cause the cycle to do a wheelie. If you decrease throttle, you will cause the front wheel to come back down again. These throttle functions are monitored by the two comparators at L10. The momentum signal being compared is the common signal going into both comparators. The instantaneous throttle change will be present at the other comparison inputs. When the up comparator output goes high, it will enable a gate to clock the counter up a rate of gravity. When the output of the down comparator goes low, it will turn on a gate, which in turn will enable another gate to clock the counter down at a rate of gravity.

This counter will also count down whenever a bad jump occurs, only at a faster rate (64V). This gives the effect of the cycle flipping back and forth when it crashes.

In addition, this counter is reset by CYCLE RESET. When the cycle jumps, the counter is loaded so that R2 and R3 are 1 and 0. This holds the cycle in a half-wheelie position as it jumps over the buses.

**3.4.14 FLIP CIRCUIT (SHEET 3, ZONES C 2-4):** The flip circuit is at flip-flop N4 and at gate N8 pin 6. When the inputs to the gate R2 and R3 are both high, the cycle is in the flip position. This data is clocked into the flip-flop and the circuit is now in the flip mode. The cycle will remain in this mode until cycle reset occurs. When FLIP is active and the cyclist has not had a bad jump, the data will cause the gravity counter to reset. This will keep the cycle angle counter from changing the state of R2 or R3, keeping the cycle in the flip position after FLIP has been set. When FLIP goes high, it will also trigger the flip timer. This timer will allow the cycle to skid for a short time before it triggers CYCLE RESET.

**3.4.15 CYCLE RESET (SHEET 3, ZONES D 1-3):** The cycle reset pulse is generated by the one-shot N6 pin 10. This one-shot is triggered by any one of the following: start of the game, end of flip time, jump occurring with screech (a skid), sequence reset, or out-of-sequence reset.

The cycle reset pulse resets the horizontal and vertical motion counters. This pulse causes the cycle to start off at the beginning of the top track. It also resets the direction in which the cycle will point at the beginning of each run. It resets the cycle angle counter to zero, causing the cycle to start off with both wheels on the track. It also resets the cycle after various sequences have occurred, such as a flip, bad jump, or good jump. A sequence reset will occur when the cycle reaches the end of the last track. An out-of-sequence reset will occur if the cycle isn't down on the road while traveling over the first and second tracks.

**3.4.16 GOOD OR BAD JUMP (SHEET 2, ZONES B 3 & 4):** This circuit consists of the four flip-flops K7 pins 5 and 9, J7 pin 5, and A5 pin 8. The last two of these flip-flops detect where H WINDOW is with respect to the movable ramp zone. The data from this detector circuit is sampled at the end of the jump by the other two flip-flops. If the data at the GOOD JUMP flip-flop is high when JUMP goes high, then GOOD JUMP becomes active. If the data at the BAD JUMP flip-flop is high when JUMP goes high, then BAD JUMP becomes active. Or, if the cycle comes in coincidence with the buses, a bus hit results, causing BAD JUMP to be set.

**3.4.17 THROTTLE DISABLE (SHEET 3, ZONES C 7-8):** Throttle disable is controlled by transistor Q14. When a flip or a jump occurs, it will turn off this transistor, releasing the negative potential to the throttle pot. Because of this feature, no matter what position the pot is in, the

voltage will be the same as the side of the pot with the positive potential.

The throttle is also disabled during the attract mode. This is done by turning off analog switch K11 pin 10. In the attract mode, the cycle speed is set by the 220K, 100K, and 330K resistor voltage divider from ground to +5V.

**3.4.18 RETURN THROTTLE "WINDOW" (SHEET 3, ZONES D 7-8):** At the end of each run, CYCLE RESET will go low. This will set the RS flip-flop at N5 pin 11 and M5 pin 6. This flip-flop controls SPEED KILL and RETURN THROTTLE. The SPEED KILL signal will disable any counting by the cycle angle counter. RETURN THROTTLE will enable the lighted rectangle at the upper right corner of the screen. When the RS flip-flop is set, it will turn on transistor Q17, charging the 22- $\mu$ f capacitor to +5V. This resets the starting speed to minimum. Also, when the flip-flop is set, it will turn off the speed pulse oscillator by applying +5V to pin 5 (mentioned earlier in paragraph 3.4.3). The RS flip-flop is reset in the attract mode or when the throttle is returned. The throttle being returned is detected by transistor Q16. This transistor will turn off when throttle voltage is greater than +4.3V.

**3.4.19 ROADWAY CIRCUIT (SHEET 1, ZONES A 4-5 AND B 4-5):** This circuit consists of two D flip-flops at location H3 and the NAND gate H4 pin 6. The RS flip-flop creates the vertical zone for the RETURN THROTTLE and EXTENDED PLAY "windows", and also disables the uppermost track in that vertical position. The D flip-flop, in combination with the NAND gate, yields one line every 32V. The 1H input to the NAND gate cause the track to be a dotted line.

**3.4.20 VIDEO GENERATION (SHEET 1, ZONES A 1-5 AND B 1-5):** Video is the combination of comp sync with black video and white video. Comp sync has already been explained in paragraph 3.4.2.

The black video level is represented by all of the dark information displayed on the screen. The white video level consists of all the light information. The two rectangles at the top of the screen, the two squares beside the two scores, and the cycle are all capable of being either black or white video level. This is controlled through the gating of BLACK VIDEO or WHITE VIDEO. For example, if the cycle is white, it is enabled through the WHITE VIDEO gating and disabled through the BLACK VIDEO gating. If the cycle is black, it is enabled through the black gating and disabled through the white gating.

Other video levels in this game are as follows: the first player's score is always white, and the second player's black. The track or roadway is always black, as are the ramps. The buses are always white. The remaining background is gray video level.

**3.4.21 GRAVITY GENERATOR (SHEET 3, ZONES B 1-2 AND C 1-2):** This circuit consists of a counter at L5, a flip-flop at F6, and a gate at L6. GRAVITY is a pulse that occurs once every 16 V RESET pulses. The counter counts V RESET pulses; the flip-flop and gate shape the gravity pulse.

**3.4.22 POWER SUPPLIES (SHEET 2, ZONES C 1-3 AND D 1-3):** The +5V supply uses the standard 16.5V secondary of the transformer. The center tap of the secondary is grounded. The two alternating-current outputs are 180° out of phase, and are positively rectified through the two A14U diodes. This gives full-wave rectification.

Next, there is an 8000- $\mu$ f filter capacitor. This capacitor will be charged through the A14U diodes, causing an unregulated voltage of approximately +10V. The LM309 will then take this voltage and regulate it down to 5 volts. This 4 $\Omega$  10W resistor will act as an additional current source, passing current around the LM309.

The -5V power supply is similar to the +5V supply in the use of a center-tapped secondary. However, the polarity of the diodes is reversed, causing the 200- $\mu$ f filter capacitor to charge negatively. This secondary is of the 25V winding type.

A zener diode and a 470 $\Omega$  resistor are connected in series from ground to the 200- $\mu$ f capacitor. This part of the circuit will set up a 5.6-volt reference point. This reference voltage is connected to the base of the emitter follower circuit at Q2. -5 volts will be supplied at the emitter of this circuit. The reason is that at such a voltage, the emitter-base junction of Q2 will be forward-biased and current will be supplied through the collector.

The last supply is the +18V supply. It is unregulated and hence similar to the voltage present at the 8000- $\mu$ f capacitor, except the capacitance here is 2000 $\mu$ f and the voltage is greater.

**3.4.23 SOUND CIRCUITS (SHEET 3, ZONES A 2-8 AND B 208):** The Stunt Cycle game has five different types of sounds. They are motor sound, screech (or skid) sound, bounce sound, crash sound, and crowd cheer. These five are summed together through resistors and then amplified by the LM380.

All sounds are turned off in the attract mode by transistor Q1. This transistor pulls the bypass voltage on the LM380 down to ground, which turns off the LM380.

The motor sound is generated by half of 556 (at E9 pin 5) and by one of four operational amplifiers (op amps) at F11 pin 4. The 556 is a non-retriggerable one-shot with a constant output pulse width. This device is triggered by the motor pulses, which come from counter C1. They are equal to the frequency of the speed pulses divided by two. The pulse output from the one-shot is then sent through the bandpass filter made by the op amp. This bandpass filter will take the square pulse from the one-shot and shape it

into something closer to a sine wave.

As the frequency of the motor pulses increases, the time between each pulse decreases. When the time between each motor pulse becomes less than the time of the one-shot, the latter will trigger on every other motor pulse. The reason is that the one-shot must completely time out before it can be retriggered. The result is an illusion of shifting gears.

The screech sound is generated by half of the 556 (at E9 pin 9). This device is used in the astable mode of operation (self-oscillating). What gives this oscillator the randomness of a screech sound is the change in the control voltage. This voltage depends on the noise generator. The source of noise is the transistor Q13. The emitter-base junction of this transistor is reverse-biased. The reverse breakdown voltage of this junction is 5 volts. At small current levels this breakdown can be used to generate noise without damage to the transistor.

The noise is then amplified by an op amp. This op amp has two diodes connected from input to output. The amplifier will yield maximum gain, until either diode is forward-biased, giving negative feedback current to the input. At this time the amplifier will yield unity gain. The two diodes serve as an automatic gain control (AGC) circuit. The output from this op amp is amplified by the 4001 gate with a one-meg-ohm feedback resistor. The output of this resistor then feeds the control voltage of the screech oscillator.

The whistle sound in the crowd cheer is generated by the two halves of 556, at C9. The first 556 controls how long the whistle sound lasts and the length of time between each reoccurrence. The other half of the device is used in the self-oscillating mode.

The frequency of oscillation depends on the voltage level at the 100- $\mu$ f capacitor. This capacitor is discharged each time the oscillator is reset. As the capacitor charges, the frequency of oscillation decreases.

The roar of the crowd in this sound is made up of bandpassed noise. The op amp at F11 pin 3 is used as a bandpass filter. The output of this filter goes to another 4001 gate. This input to the gate is used as an amplifier. The other input is the control to crowd cheer sound. When the GOOD JUMP signal goes high, transistor Q12 will discharge the 1 $\mu$ f capacitor on the input to the 4001 gate. At this time the gate is in the amplifier mode. As the 1 $\mu$ f capacitor charges, it will eventually turn off the gate, and the crowd cheer sound will stop.

The crash sound is also made from bandpassed noise. The bandpass filter is again made from one of the four op amps at F11 pin 10. The output of this filter is amplified by another 4001 gate. From here the signal goes to a voltage-controlled amplifier (VCA). When the crash signal goes high, it turns on transistor Q8. This discharges the

10 $\mu$ f capacitor, causing the VCA to turn on. As the 10 $\mu$ f capacitor charges, the output of the VCA decreases to nothing.

The bounce sound is produced the same way as the crash sound. Instead of processed noise, a digital signal is derived from the game electronics to go into the VCA.

**3.4.24 COIN CIRCUIT (SHEET 1, ZONES A & B 5-8 PLUS C 7-8):** The coin circuit is capable of storing up to 15 credits. A switch on the PCB sets the game for either one or two credits per coin. The part of the circuit with the two KJ flip-flops discriminates between one or two credits per coin. If the 1P/2P switch is in the 1P or high position when the coin switch is pushed, the J input to the second flip-flop will be high. This will cause the dual JK flip-flop circuit to produce only one coin pulse. If the 1P/2P switch is in the 2P or low position, it will disable the 7450 gate.

This means that the J input to the second flip-flop will not go high when the coin switch is pushed. This will cause the COIN signal to pulse low two times, giving two credits.

Credit is stored in the credit counter. Each COIN pulse will cause the credit counter to increment one count. When the game is started, the counter will be decremented either one or two credits, depending on whether the player selects a one- or two-player game.

The two inverters at K8 are used to debounce the coin switch. The flip-flop H8 will test the width of the coin pulse for a valid coin. When a free game is achieved, credit will be added in the same way a coin increases credit. The FREE COIN signal will be gated with the 2 PLAYER MODE signal to determine if one credit or two credits should be added. This is the same way that the coin switch was gated with the 1P/2P switch to determine one or two credits.

The free coin circuit consists of the two flip-flops at F8 and NAND gate at H9 pin 8. When FREE GAME goes high with the free game switch in the high position, it will reset the first flip-flop. This will clock in a free coin. Another free coin will not be allowed until after the next game is played or another coin is put in the machine. A start occurs when the player has credit and depresses a start switch. If the player has only one credit, only a one-player start will be enabled. If the player has more than one credit, the 2 PLAYER CREDIT signal will become active and enable a two-player start, if such is desired. Having a two-player or one-player start will set or reset the two-player mode flip-flop.

The 2 PLAYER MODE signal will control the game in functioning as a one- or two-player game. This signal also controls the counting down of either one or two credits.

If the 2 PLAYER MODE signal is high, it will enable the V RAMP signal to apply an extra down clock pulse to the credit counter. This clocks off two credits instead of just one. When the start signal goes high, it will be clocked into the ATTRACT flip-flop by 256V. The ATTRACT flip-flop will remain in the set condition until it is reset by the end of the game. The circuit that consist of transistors Q10 and Q11 is a type of flip-flop circuit. This circuit is made to power on in the reset state. The output of this circuit is the Q signal. This signal resets the ATTRACT flip-flop, so that when power is applied to the circuitry, it will not start in the same mode. The Q signal will also clear the credit counter when powering up.

The first coin that is put into the machine after power is applied will set the transistor flip-flop, enabling credit and the start of the game. The transistor flip-flop can also be reset by transistor Q9. This should occur only if a static spark occurs near the game and is received by the antenna. The credit lamps are turned on the SCRs, which are controlled by the CREDIT and 2 PLAYER CREDIT signals.

## IV. INSTALLATION INSTRUCTIONS

15

### 4.1 UNPACKED INSTRUCTIONS

**4.1.1 EXAMINATION FOR SHIPPING DAMAGE:** Before shipment from the factory, components and sub-assemblies of each game are carefully checked for proper operation. However, during shipment some adjustments may have changed or parts may have been damaged. Upon initial removal of the game from the shipping container, examine the exterior of the cabinet; then open the rear panel access doors and also examine the interior. Any shipping damage such as a dented, cracked or broken cabinet, sub-assemblies broken loose, etc., should be reported immediately to the shipper and to Atari, Inc.

**4.1.2 MECHANICAL INSPECTION:** Once it has been determined that the game has been received in good condition, next carefully inspect the interior parts and verify the following:

- (a) All slip-on and plug-in connectors are firmly seated (particularly the PCB edge connector)
- (b) The fuses are all seated in their holders
- (c) No loose foreign objects are present (especially metal objects which could cause electrical short circuits)
- (d) No harness wires have become disconnected or pulled loose. Be sure *all* major assemblies have been checked — the TV monitor, the printed circuit board, the push-button switches and lamps on the front panel, the speaker assembly, the coin mechanism, and the interlock switches activated by the rear panel access doors.

Do not go on to the remaining paragraphs in this section until the above material inspection has been thoroughly performed.

### 4.2 ENERGIZING THE GAME

**4.2.1 APPLICATION OF AC POWER:** Close the rear panel access doors, making sure that they are completely shut at the bottom, and remove the locking key. Plug the power cord into an AC outlet providing the AC power listed in the Specifications (Section II of this manual). The wall outlet must accept a three-prong plug and the receptacle must be connected to a good earth ground. After the power cord has been plugged in, the proper response from the game is that images appear on the TV screen.

If there is no response from the game, unplug the power cord and check the AC wall outlet. A simple, safe way to check for presence of AC power at the wall outlet is to plug in an appliance known to be working properly, such as a table lamp, radio, or an electric clock. If the wall outlet passes the check, then presume that the trouble is with the game and refer to Section VI of this manual.

*(CAUTION: No trouble-shooting steps should be attempted inside the cabinet by anyone not familiar with safety measures and repair procedures on electrical equipment.)*

Do not go on to the remaining paragraphs in this section until the proper response described above has been observed.

**4.2.2 CHECK ON OPERATION OF INTERLOCK SWITCH:** The interlock switch is a safety switch connected to the AC power circuit. It is mounted inside the cabinet, towards the bottom of the rear panel access door. At the factory this switch is mechanically adjusted so that it will automatically transfer to its "off" position (switch contacts open) whenever the access door is opened. While the door is closed, the switch is transferred to the "on" position (switch contacts closed). With this arrangement only while the door is fully closed is the AC power allowed to reach the game's power supply, meaning that the game can operate.

After application of AC power per paragraph 4.2.1 above, correct operation of the interlock switch can be checked as follows:

Step 1) Unlock and open the rear panel access door. The correct response is that by the time the edge of the door has moved about 2 to 3 inches away from the cabinet, the TV screen should go dark, verifying that the interlock switch has automatically transferred to "off". While opening the access door, do not insert fingers inside the cabinet, and do not allow foreign objects to fall inside.

Step 2) If images are still present on the TV screen even after the door has been opened, immediately close and lock the door, and unplug the power cord from the wall outlet. Then refer to Section VI of this manual to replace and/or adjust the interlock switch. If the correct response was obtained, then close and lock the access door.

Do not go on to the remaining paragraphs in this section until the operation of the interlock switch has been checked and found to be correct.

### 4.3 GAME STRUCTURING

Before putting the game into operation at the game site, the game structuring should be defined by the owner/operator. The term *game structuring* refers to the rules governing play. Paragraph 3.3.4 in this manual covers the owner/operator options provided and describes their effect on game structuring.

Adjustment of the Credits-Per-Coin option consists of manually changing the position of a two-position switch mounted on the printed circuit board inside the cabinet. The same technique is also used on another two-position switch right beside it, namely for the Free Game option. The Free Game Control option and the Number-of-Misses option are both implemented on two separate hexadecimal dip switches also on the PCB. These are adjusted by using a small screwdriver.



Before performing any of the four adjustments, the game should be de-energized or not operating. Further, it is also recommended that the power cord be unplugged beforehand.

Unlock and open the rear panel access door; doing this should cause the interlock switch to de-energize the game, as described in paragraph 4.2.2. If the interlock switch fails to de-energize the game, then immediately close and lock the door, unplug the power cord, and refer to Section VI of this manual to adjust and/or replace the switch.

While being careful to avoid touching any parts of body against the TV chassis components or other wiring connections inside the cabinet, find the printed circuit board. For ease in making the adjustments, it may be necessary to remove this board. To do so, unplug the edge connector and slide the board out gently along its guides.

**4.3.1 ADJUSTMENT OF CREDITS-PER-COIN OPTION:** On the PCB find the switch S1 mounted nearest the large black heat sink, in the upper right corner if you hold the board component side facing you and edge connector at the right. For this and the remaining three options, see the simplified drawing in Figure 4-1 below. The location of this switch is also shown on drawing number A004128. Note the letters "1P" and "2P" engraved on the board's surface, alongside the switch.

To structure the game for one credit per coin, manually slide the switch stud toward the letters "1P" as far as it will go. To structure the game for two credits per coin, manually slide the switch stud toward the letters "2P" as far as it will go. For more detailed information on the meaning of credits in one-player and two-player games, see paragraph 3.3.3 of this manual.

After doing this, make sure that no foreign objects have been dropped inside the cabinet, and then close and lock the access door.

**4.3.2 ADJUSTMENT OF FREE-GAME OPTION:** On the PCB find the switch S2 mounted to the left of the Credits-Per-Coin Switch, described above. The location of this switch is also shown on drawing number A004128. Note the letters "FG" and "FG" engraved on the board's surface, alongside the switch.

To structure the game for allowing free play, manually slide the switch stud toward the letters "FG" as far as it will go. To structure the game for prohibiting any free play, manually slide the switch stud toward the letter "FG" as far as it will go. For more detailed information on the exact definition of free play, see paragraph 3.3.3 of this manual.

**4.3.3 ADJUSTMENT OF FREE-GAME-CONTROL OPTION:** Remove the PCB from inside the cabinet by unplugging its edge connector and sliding the board all the way out of its guides. Then find the hexadecimal dip switch located in position F-7. Such a device has never been used before in Atari games; some owners/operators may therefore be unfamiliar with this type of switch. We suggest using a small flat-head screwdriver to change the settings of the switch; the switch itself should not be removed from the integrated-circuit socket. When turning the screwdriver, be sure that gentle, even pressure is used; do not let the tool slip and possibly scratch the PCB surface or damage other components. See Figure 4-1 for a detailed view of the switch's markings.

Each setting of the switch represents a certain number of buses to be jumped successfully before a free game will be allowed. See the table below for exact settings.

**4.3.4 ADJUSTMENT OF NUMBER-OF-MISSES OPTION:** Remove the PCB from inside the cabinet as described in the paragraph above. Then find the hexadecimal dip switch located in position F-5. The guidelines regarding changing the switch's settings (paragraph 4.3.3) plus the illustration in Figure 4-1 are equally applicable here. Each setting of the switch represents a certain number of misses (i.e., unsuccessful attempts at jumping a row of buses) permitted before a player's game will end. See the table below for exact settings.

Switch Position	0	1	2	3	4	5	6	7
	-OR-							
	8	9	A	B	C	D	E	F
Number of Misses Allowed	0	1	2	3	4	5	6	7

Table 4-2 Settings of Switch Governing Number of Misses Allowed (Switch Located in PCB Position F-5)

Switch Position	0	1	2	3	4	5	6	7	8	9	A	B	C	D	E	F
Number of Buses to Jump for Free Game	12	13	14	15	16	17	18	19	20	21	22	23	24	25	26	27

Table 4-1 Settings of Free-Game-Control Switch (Switch Located in PCB Position F-7)

---

After the adjustments have all been made, replace the PCB inside the cabinet. Make sure that the PCB edge connector is plugged in securely and in the correct orientation. Also make sure that no foreign objects have been dropped inside the cabinet. Then close and lock the access door.

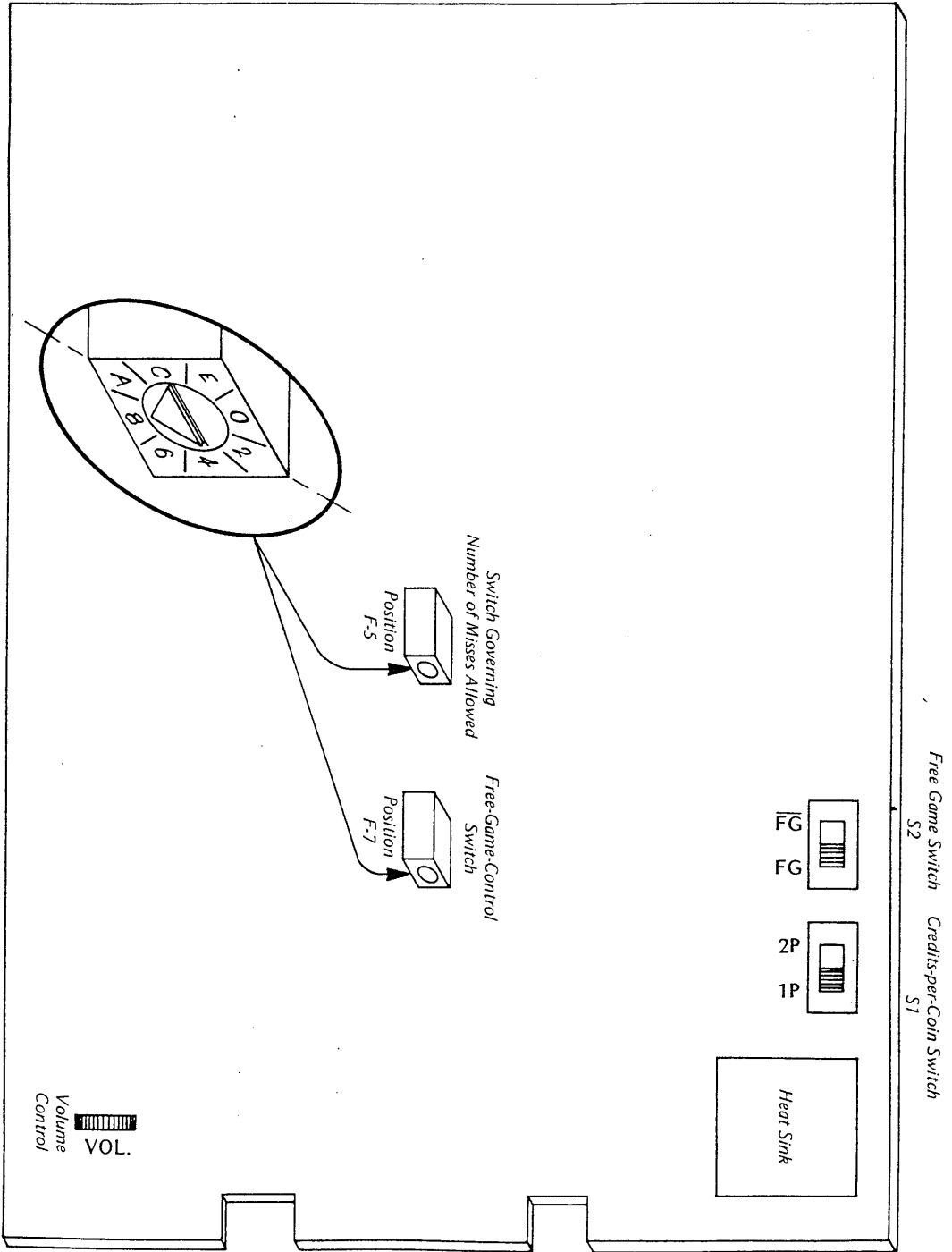

Figure 4-1 Locations of Owner/Operator-Adjustable Options on PCB

## V. MAINTENANCE AND ADJUSTMENTS

### 5.1 ROUTINE MAINTENANCE

Due to its solid-state electronic circuitry, the Atari Stunt Cycle game should require very little periodic maintenance and only occasional adjustment.

**5.1.1 CLEANING:** Game cabinets and glass may be cleaned with any non-abrasive household cleaner. If desired, special coin machine cleaners which leave no residue can be obtained from distributors.

**5.1.2 LUBRICATION:** About once every three months lightly spray the rejector linkage portion of the coin acceptor inside the coin mechanism. Use WD-40® or similar lubricant, and *avoid* spraying the entire coin acceptor. Potentiometer shafts must *never* be lubricated in any way.

### 5.2 ADJUSTMENTS ON TV MONITOR

The TV monitor need be adjusted *only* when the picture is distorted, or if contrast or brightness seems out of adjustment.

*NOTE: Access to the TV monitor is possible only from inside the cabinet, and these adjustments are made while the game is energized. Therefore only those familiar with safety measures and repair procedures on electrical equipment should make these adjustments.*

The TV monitor's adjustments function like those of a conventional commercial TV set, except that the volume adjustment has no effect. The Stunt Cycle game produces

its sound in a speaker separate from the TV monitor. Figure 5-1 shows the location of these adjustments on the rear of the TV monitor chassis. The following are general guidelines to follow while making these adjustments:

**BRITE (Brightness)**—This should be adjusted before the contrast. Adjust the brightness so that the white lines covering the screen just barely disappear when the brightness is turned up.

**CONT (Contrast)**—Adjust so that the images are as bright as possible against the dark background without being blurred.

**HORIZ HOLD (Horizontal Hold)**—Adjust if the picture is slightly off-center horizontally, if the picture is broken up into a series of diagonal lines. Adjust for a stable, centered picture.

**VERT HOLD (Vertical Hold)**—This needs adjustment only if the picture appears to be rolling up or down the screen. Adjust for a stable, centered picture.

### 5.3 ADJUSTMENT OF SPEAKER VOLUME

The loudness of the sounds produced during game play can be adjusted with the potentiometer R91, as illustrated in Figure 4-1 of this manual. The adjustment is done by manually moving the stud on top of the potentiometer body, as shown in Figure 5-2. This potentiometer is mounted on the printed circuit board inside the cabinet. Drawing number A004128, the PCB assembly drawing included in Section VII of this manual, shows this potentiometer in the lower right corner of the board.

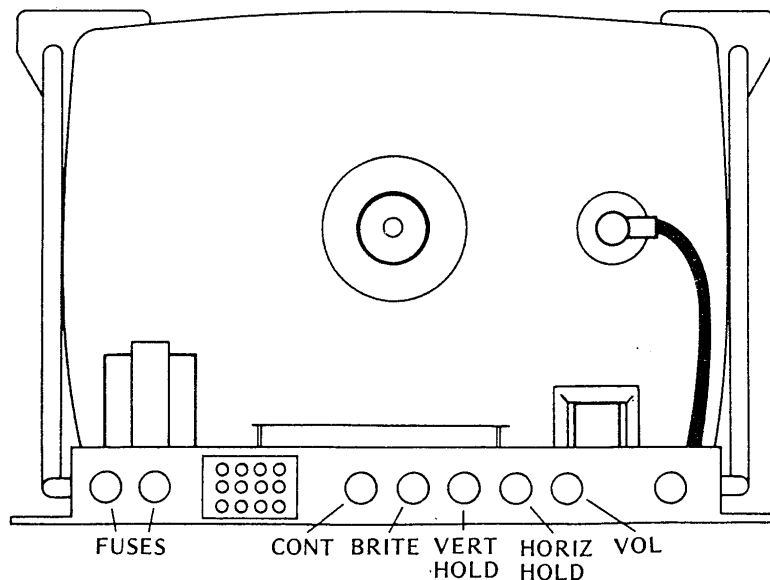

Figure 5-1 Location of Adjustments on TV Chassis

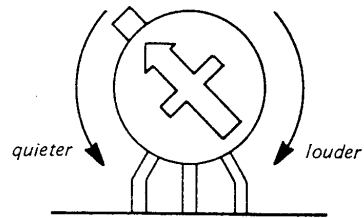

Figure 5-2 Speaker Volume Potentiometer

# VI. TROUBLESHOOTING AND REPAIR

## 6.1 GENERAL PROCEDURE

*This section describes troubleshooting procedures in detail sufficient for a person with moderate technical ability to understand. However, for those interested in gaining more information on video game technology, especially the electronics, we recommend reading the Video Game Operator's Handbook, manual no. TM-043. This book is available from Atari, Inc., attn. Customer Service Dept., 2175 Martin Avenue, Santa Clara, CA 95050, for \$5.00 each, or from your distributor.*

**6.1.1 IDENTIFYING THE TROUBLE AREA:** The first troubleshooting step should be to note all observable trouble symptoms. Examples of symptoms are: depositing a coin produces no game response, no sound coming out of the speaker at any time, no picture on the TV screen. At the same time also note the game features that still work. A systematic way of checking game operation is to perform the functional check given in Section IV of this manual. Carefully train your eye to pick up all clues; by doing this an experienced troubleshooter can often spot the cause of a trouble even before he opens the cabinet.

Keeping these observations in mind, use the understanding of game operation gained from the Theory of Operation (Section III) and the schematic drawings (Section VII). Next narrow down the suspected cause of the trouble to a specific area or areas of the game: the coin mechanism, TV monitor, harness and front panel components (switches, lamps, LEDs, pistol assembly), electronics tray, printed circuit board, and power cord. Be careful not to overlook possible trouble areas that may seem too obvious: a power cord plug that has worked loose from the wall outlet and is no longer fully seated in the receptacle, or a rear panel access door that is not fully closed (thus causing the interrupt switch to block the AC power path to the game).

**6.1.2 LOCATING THE TROUBLE CAUSE:** Once a problem has been narrowed down to one or more areas, the next step is to perform various tests and measurements to isolate a specific cause of the trouble. Remember that sometimes a very complicated problem, such as erratic game operation, can be traced to a simple cause—the printed circuit board not being fully seated in its edge connector. Start with the most suspect area and trace backwards from the point where the trouble is first observable, using a process of elimination to eventually locate the faulty component, connection, etc. For example, if no sound is audible during game play, first check for a signal at the speaker leads. If no signal is present there, go back through the wiring harness connections to the printed circuit board. If there is still no signal, then systematically check back through the various components of the sound generation circuit.

Substitution of parts is a legitimate and easy way to isolate the cause. For instance, if the PCB is the suspected trouble area, remove it and substitute a known-to-be-good PCB. Then check for correct game operation. Similarly, to check the TV monitor, connect the game to a known-to-be-good monitor. The harness can often be checked by substitution also. Substitute both a known-to-be-good PCB and TV monitor. If the trouble still persists, the harness must be at fault.

While locating the trouble cause, use the technical descriptions in Section III as guides for correct circuit-level operation, and the schematic drawings of Section VII as roadmaps for tracing signal flow paths.

The test equipment for use in troubleshooting is discussed in paragraph 6.2.

**6.1.3 CORRECTING THE TROUBLE CAUSE:** In practice, the steps required to correct troubles can range from simple adjustments (fully seating the PCB in its edge connector, changing the setting on a potentiometer, adjusting the picture controls on the TV monitor) to repair of loose connections and replacement of defective parts. Extreme care should be exercised when removing integrated circuit devices and discrete components. Use a 40-watt soldering iron with a small tip designed especially for IC work. To remove an IC device, follow this procedure:

Remove all solder from *both* sides of the PCB, first melting it with the hot iron and then sucking up the molten solder with a Soldapull® solder sucker. After all the solder is gone, remove the IC device by gently prying up. Afterwards clean the area thoroughly, using an approved PCB cleaning solution to remove any traces of flux and dirt. Alcohol will do in a pinch, if necessary.

Insert the new IC device using an IC insertion tool, making sure that the reference notch is oriented correctly and that the device's leads are not bent during insertion into the board. Afterwards, be sure to solder each lead on *both* sides of the PCB, using as little solder as possible. After soldering, clean the area thoroughly to remove the flux.

Observe the same removal and insertion procedures when replacing discrete components. Trim the leads as close as possible and be sure to orient diodes and capacitors correctly.

**6.1.4 VERIFYING CORRECT GAME OPERATION:** After locating and correcting the cause of a trouble, re-energize the game and perform a final check on correct game operation. Doing this will verify that your troubleshooting was correct. If the game operation is still not correct, go back and double-check your work. Make sure that any replaced components were installed correctly. If this was done properly, then start the troubleshooting steps over again. Keep in mind that there may be more than one trouble at a time, and that correcting one trouble can some-

times bring previously undetectable troubles to light.

This verification is especially important when the original trouble had been intermittent, that is, was not happening all the time.

## 6.2 TEST EQUIPMENT

Electronic troubleshooting of a video game essentially consists of checking for the presence of various signals and of examining their condition. A signal can be thought of as acting like a "messenger" that carries instructions from one unit or circuit to another. Many different types of signals are produced in a video game, and for this reason several unusual and perhaps unfamiliar types of test instruments are used during troubleshooting. Each instrument has its own set of advantages and disadvantages for examining a given type of signal, and both the depth of the intended troubleshooting capability and budget will determine what instruments will be needed. Some instruments are basic and essential, no matter what size of service facility, while other optional instruments are desirable because they make troubleshooting easier and quicker.

### 6.2.1 BASIC TEST EQUIPMENT:

(a) *The Video Probe.* This is a simple but invaluable instrument having two leads—a test-clip lead and a test-probe lead. During troubleshooting of video signals the test-clip lead is left connected to the game side of the video coupling capacitor. On the Stunt Cycle game this point is the junction of resistors R13, R14, and R15 on the PCB.

When the test-probe lead is then connected to any video developmental signal, that signal will be coupled to the video signal going to the TV monitor and a video probe picture will appear on the TV screen. The shape and other characteristics of this picture will give information about the signal being probed. The video probe is suited for troubleshooting synchronization and image signals, but will not be useful for extremely fast signals (such as the clock) or for very slow analog or digital signals.

A video probe can be constructed in a few minutes from these common electrical components: a length of 20 AWG (American Wire Gauge) rubber-coated wire, a 4.7K-ohm, ¼-watt carbon resistor, and two test leads. For the leads, use a single Mouser test clip (Mouser #131C 301 or 302) attached to one end of the wire, and a test prod containing the resistor on the other.

To assemble the video probe, proceed as follows: Remove the cap from the test clip and strip 3/16 inch off each end of the wire. Solder one end to the post in the test clip, thread the other end through the hole in the cap, and snap on the cap. Next unscrew the plastic body of the test prod from the point and trim both leads of the resistor to a 3/16-inch length. Solder one resistor lead to the inside of the point. Thread the other end of the wire through the hole in the body and solder it to the other

resistor lead; screw the body back onto the point.

(b) *The Logic Probe.* This is a test instrument designed for fast verification of digital IC outputs. It is small, convenient to carry, easy to read, and relatively inexpensive. The logic probe derives its power from the system under test; it has two power leads, one for connection to ground and the other to +5 volts DC. When the logic probe's tip is held against a digital signal point, three colored lamps in the tip will indicate the signal's condition or state, as follows:

- The red lamp lit indicates a high or logic level 1 (for TTL components, this is +2.4 to +5 volts)
- The white lamp lit indicates a low or logic level 0 (for TTL components, this is 0 to +0.8 volt)
- The blue lamp lit indicates that the signal is changing states
- No lamps lit indicate the grey region between 0 and 1 (for TTL this is between +0.8 and +2.4 volts)

A circuit shorted to ground will illuminate the white lamp and an open circuit will illuminate the red lamp.

This logic probe is readily available from electronic supply sources; a commercial model found satisfactory is the Kurz-Kasch model LP 520.

(c) *The Logic Pulser.* This test instrument is similar in size and shape to the logic probe, and it also derives its power from the system under test. When the logic pulser's tip is held against a digital signal point, the source and sink capabilities of the pulser override any IC output and the point is driven to the opposite logic level. If the point that the logic pulser is held against is low, pressing the switch on the side of the pulser will introduce a high pulse. Conversely, pulsing a high line will pull that line low momentarily.

During troubleshooting the logic pulser allows stimulation of in-circuit ICs with a shaped digital pulse. For example, a certain feature of the game may not be working and you suspect that a circuit is not receiving the necessary signal. Use the pulser to imitate that signal and if the circuit begins working, you have proved that the signal was in fact missing and you can begin tracking it down. This technique is very similar to jumping coils in electromechanical games such as pinball machines.

In addition to the regular "pulse" button, there is another switch mounted on the logic pulser. When this switch is set in the "rep" mode, the instrument pulses the digital signal point at a 5-Hz rate or 5 times per second. This extremely low rate is slow enough to allow watching events initiated by the pulser. Counter outputs, for example, are more easily observed when the counter is pulsed or clocked at this rate.

The logic pulser is also readily available from electronic supply sources; a commercial model found satisfactory is the Kurz-Kasch model HL 583.

(d) *Oscilloscope.* The most versatile test instrument, and also the most expensive, is the oscilloscope. The high-speed TTL integrated circuits used in video games produce fast-rise-time signals. The oscilloscope should have a 50-MHz bandwidth, dual trace and dual time base capability. These latter features allow examination of both input and output signals simultaneously, so that precise timing relationships can be checked. The oscilloscope should also have provision for internal or external sync.

Of the newer, solid-state oscilloscopes, a satisfactory model is the Tektronix 465.

(e) *VOM or Volt-Ohmmeter.* This common measuring instrument is extremely useful in video game troubleshooting. It can be used to check line voltage, transformer secondary windings, continuity, resistance, power supply voltages, and to some extent used for measurements in the analog circuitry.

One commercial model found satisfactory is the Simpson 260.

#### 6.2.2 OPTIONAL TEST EQUIPMENT:

(a) *The Logic Comparator.* This test instrument's main benefit is that it can be used to check the functioning of an integrated circuit device while the device is still in place on the printed circuit board. The logic comparator performs the check by comparing the suspect ICs functioning with that of an identical-type reference IC mounted in the instrument itself. Suppose that the functioning of a type-74193 device on the PCB is suspected to be defective. First insert a program card with a known-to-be-good 74193 into the logic comparator, and then clip the comparator test leads onto the leads of the suspect device. If there are any logic state differences between the reference IC and the suspect IC under test, then an LED on the logic comparator will light up to indicate which output is not functioning correctly. Once a defective IC has been located, it should be replaced.

Logic comparators are readily available from electronic supply sources.

(b) *Atari Universal Test Fixture.* In situations where a large number of video games are being serviced, investment in the Universal Test Fixture will be justified. This item of test equipment forms a test station for troubleshooting printed circuit boards after they have been removed from the game cabinet. The Universal Test Fixture has a full set of controls for operating the game and also has its own TV monitor. The game's PCB is plugged into an edge connector mounted on the side of the Fixture; with this arrangement the PCB is positioned in a convenient way for connecting probes and other test instruments.

A program card inserted into a receptacle in the top of fixture takes the place of the game's interconnect wires. The program card thus sets up the Fixture for each particular game; the game's name is clearly printed on the program

card itself.

With the Universal Test Fixture the method of troubleshooting via substitution of known-to-be-good parts is made fast and convenient. For example, suppose that the TV picture in a game is completely broken up and you want to determine whether the game or monitor is causing the problem. Remove the PCB and plug it into the Fixture's edge connector, and also insert the correct program card for that game. If the picture on the Fixture's monitor is correct, then you know that the problem lies in the game's monitor.

### 6.3 SPECIFIC TROUBLESHOOTING INFORMATION

The following subparagraphs give additional troubleshooting information about certain areas of the Stunt Cycle game.

**6.3.1 ANTENNA STATIC MODIFICATION:** The antenna is a wire inside the cabinet, approximately one foot long, with one end connected to pin 17 of the PCB edge connector and the other end intentionally left not connected. The antenna's function is to prevent a player from getting free games by inducing a static electric charge in the coin entrance plate or any other metal part of the game—provided that the wire has been cut to optimum length.

When a static discharge occurs, an electric current is induced in this wire and an impulse is transmitted to the credit latch circuit. This impulse resets the latch, turning off game credit and switching the game over to the attract mode. To test the static modification feature, touch the end of the antenna wire with your finger. The human body usually has enough capacitance to trigger the circuitry.

Sensitivity of the static modification feature may be adjusted by changing the length of the antenna wire. Sheet 1 of drawing number A004128, the PCB assembly drawing included in Section VII of this manual, shows the location of the antenna wire's pin-out on the edge connector of the PCB. Lengthening the antenna wire increases sensitivity, so that a lesser charge will turn off game credit. Cutting the wire shorter decreases sensitivity, so that larger charge is required for triggering the circuit.

If there are problems with static charges accidentally shutting off the game, try cutting the wire shorter, in increments of  $\frac{1}{2}$  inch at a time. Be aware, however, that if the antenna wire is cut too short, players may be able to get free games by inducing a static charge in the game.

**6.3.2 TV MONITOR:** The TV monitor is a self-contained unit housed in its own chassis. A trouble's cause may be narrowed down to the monitor—either by the substitution method using a known-to-be-good monitor, or by verifying presence of AC power to the monitor power supply and presence of the *correct* composite video signal. The entire monitor can then be removed from the game



cabinet. Doing this facilitates troubleshooting steps, because all monitor components will then be accessible.

A schematic diagram of the monitor circuitry is included in Section VII of this manual. After disconnecting and removing the monitor from the game, standard TV troubleshooting techniques are adequate for locating causes of trouble. Additional servicing information is available from the monitor manufacturer (Motorola).

**6.3.3 COIN MECHANISM:** If a player inserts a coin and the game does not respond, first check the coin mechanism. If pressing the coin rejector button forces the rejector mechanism to return the coin, then examine the coin to make sure that it is genuine. If it is, then use a set of your own test coins (which should include both very new and very old, worn coins) to determine whether or not the player's coin is undersize or underweight. If your test coins are also returned, this indicates that servicing of the coin acceptor portion of the coin mechanism is called for. Generally the cause of this particular problem is an improperly adjusted magnet gate.

Inside the coin mechanism a magnet is used to test the metallic composition of the coin. Highly magnetic coins, such as those made of steel or iron, will be retained by the magnet and can be returned by actuating the wiper operating lever. Coins having comparatively high magnetic

properties will be slowed down by the magnet, and will drop off the end of the rail short of the "accept" entrance and be returned. Coins having little or no magnetic properties, such as brass or zinc coins, will pass through the magnetic field so fast that they will overshoot the "accept" entrance and be returned.

A magnetic gate adjusted with too large a gap may pass both genuine and counterfeit coins. An adjustment with too small a gap can lead to rejection of some or even all coins. Over a period of time, the screw that adjusts the magnet gate has a tendency to work loose, resulting in a gradual narrowing of the gate. At first, only the thickest (i.e., newest) coins are rejected. As time passes, more and more coins are rejected until finally player complaints lead to the calling of the game repairman.

If pressing the coin rejector button does not cause the coin to be returned, and if the game still does not respond, then check the coin mechanism to see if the coin is jammed inside.

If you are certain that the coin is genuine, and that the coin passes through the coin mechanism and into the cash box, then the lack of game response is probably due to some kind of electrical trouble. Check for signals at the electrical contacts of the coin mechanism before moving on to the harness and other parts of the circuitry.

## VI. SCHEMATICS, DRAWINGS & PARTS LISTS

---

25

<i>Number</i>	<i>Title</i>
004807	Parts List, Top Assembly
A004807	Top Assembly
004782	Parts List, Control Panel Assembly
A004782	Control Panel Assembly
003417	Parts List, Handlebars Assembly
A003417	Handlebars Assembly
004772	Harness Schematic
004775	Parts List, Electronics Tray Assembly
A004775	Electronics Tray Assembly
004128	PCB Schematic
004128	Parts List, PCB Assembly
A004128	PCB Assembly
[none]	Motorola XM501 Monitor Schematic

STUNT CYCLE



ASSEMBLY TITLE / TOP ASSEMBLY P/L A004807

PARTS LIST SPECIFICATION

Page 1 of 1

Drawn		
Checked	Mech. Eng.	
Proj. Eng.	Elec. Eng	REV. A

Rev.	Description	Date	Apprv.	Rev.	Description	Date	Apprv.
A							

Item	Part Number	Qty.	DESCRIPTION
1	A004060	1	Cabinet Assembly
2	A004782	1	Control Panel Assembly
3	A004814	1	T.V. Shelf Assembly
4	A004775	1	Electronics Tray Assembly
5	A004286-05	1	R.F. Shielding Box Assembly
6	A003637-08	1	Coin Door Assembly
7	A003102	1	Fluorescent Light Assembly
8	004072	1	Screen, Plex w/Artwork
9	002611	2	Plex Retainer
10	001638	2	Panel Mtg. Bracket
11	000869	1	Speaker Grill
12	71-2114	1	Lock Mech., Barrel Cartridge
13	004816	1	Bezel, Cardboard
14	004815-01	1	Instruction Card - Single Play
15	004815-02	1	Instruction Card - Double Play
*16	005130-01	2	Game End Card
17	70-304	1	18" Fluorescent Tube, F15T12
18	005131-01	1	Extended Play Decal
19	005131-02	2	Boob Tube Decal
20	005131-03	1	One-way Sign Decal
21	005131-04	2	House Decal
22	75-5520N	4	Bolt, Carriage, # $\frac{1}{4}$ -20 x 1.25" Lg.
23	75-015S	6	Washer, Flat, $\frac{1}{2}$ "
24	75-045	6	Washer, Split Lock, $\frac{1}{2}$ "
25	75-915S	6	Nut, Machine Hexagon, $\frac{1}{4}$ -20
26	72-5532	2	Screw, Machine, Hex Hd., # $\frac{1}{4}$ -20 x 2" Lg.
27	75-5120B	14	Bolt, Carriage, 10-24 x 1.25" Lg, Black
28	75-010S	18	Washer, Flat, #10
29	75-040	18	Washer, Split Lock, #10
30	75-911S	18	Nut, Hex, #10-24
31	72-6812	6	Screw, Sht. Mtl., Pan Hd., Phil, #8 x .75" Lg.
32	72-6608	1	Screw, Sht. Mtl., Pan Hd., Phil, #6 x .50 Lg.
33	73-77001	4	Pop Rivet
34	75-5120	2	Screw, Machine, Hex Hd., #10-24 x 1.25" Lg.
*35	005130-02	2	Game End Card

\*To be put in plastic bag and shipped in coin box.

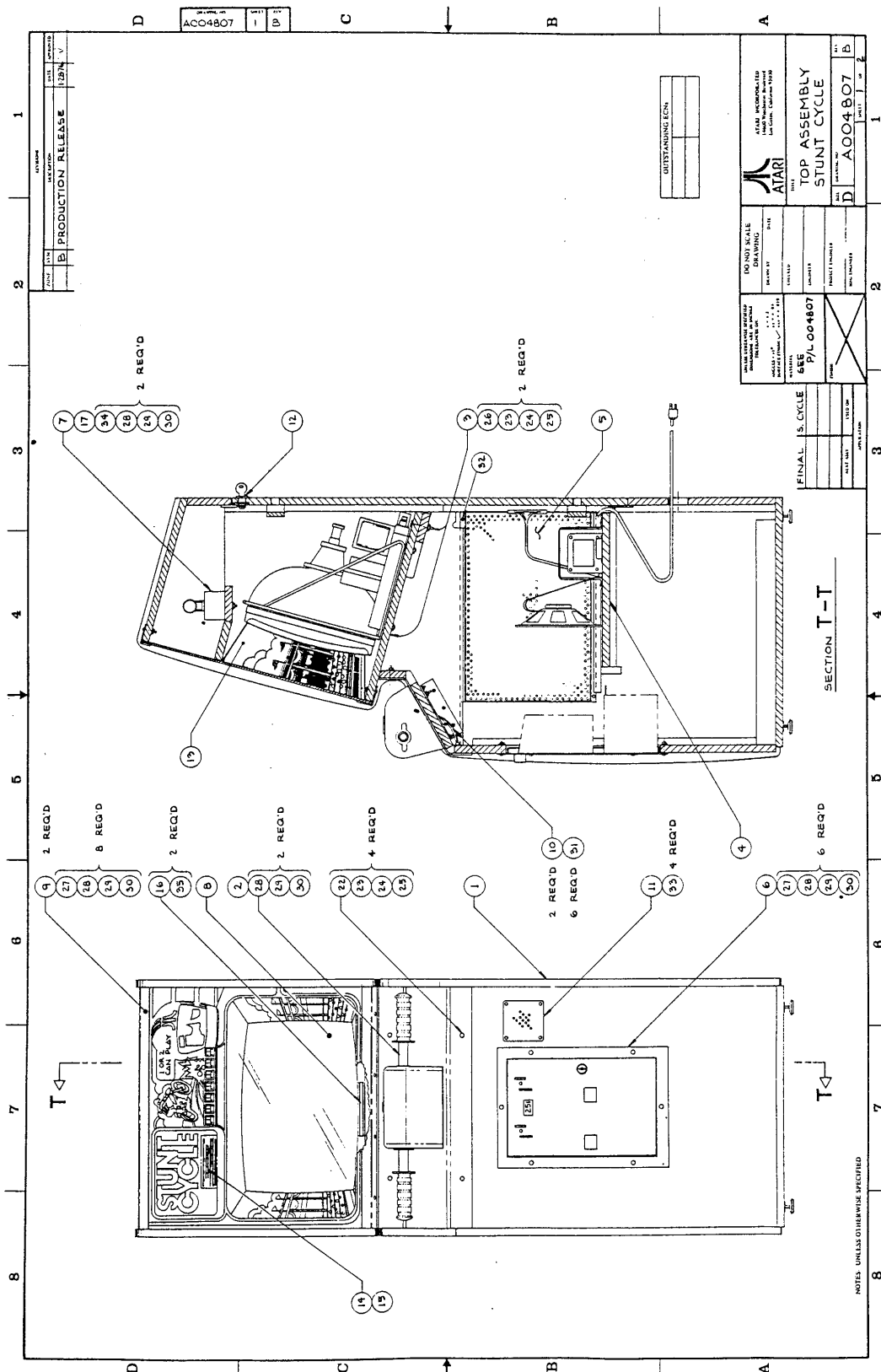

REV	DATE	BY	CHKD
1	12/24/78	V	
E. PRODUCTION RELEASE			

ACO4807 - 1 - 12

ATARI  
 ATARI INCORPORATED  
 500 AVENUE OF THE STARS  
 BERKELEY, CALIFORNIA 94705

TOP ASSEMBLY  
 STUNT CYCLE

REV. NO. ACO4807

DATE 12/24/78

BY V

CHKD

DO NOT SCALE DRAWING

DATE

DESIGNED BY

DATE

ENGINEER

DATE

FINAL: 5. CYCLE

SEE P/L 004807

UNLESS OTHERWISE SPECIFIED, ALL DIMENSIONS ARE IN INCHES AND DECIMALS THEREOF.

SCALE: 1" = 1/2" (AS SHOWN)

DATE

BY

CHKD

OUTSTANDING ECN

NOTES: UNLESS OTHERWISE SPECIFIED

STUNT CYCLE



ASSEMBLY TITLE / CONTROL PANEL ASSEMBLY P/L A004782

PARTS LIST SPECIFICATION Page 1 of 1

Drawn	
Checked	Mech. Eng
Proj. Eng.	Elec. Eng
	REV. A

Rev.	Description	Date	Apprv.	Rev.	Description	Date	Apprv.
A							

Item	Part Number	Qty.	DESCRIPTION
1	004077	1	Panel, Cover
2	A003417	1	Handlebar Assembly
3	A004304-09	1	Double Light Switch Assembly - 1 Player
4	A004304-10	1	Double Light Switch Assembly - 2 Player
5	004080	1	Board, Cover Panel
6	75-5124N	2	Bolt, Carriage #10 - 24 x 1.50" Long
7	75-010S	2	Washer, Flat #10
8	75-911S	2	Nut, Hex #10 - 24
9	75-5524N	4	Bolt, Carriage # $\frac{1}{2}$ - 20 x 1.50" Long
10	75-015S	4	Washer, Flat, $\frac{1}{4}$ "
11	75-045	4	Washer, Split Lock, $\frac{1}{4}$ "
12	75-915S	4	Nut, Machine, Hexagon

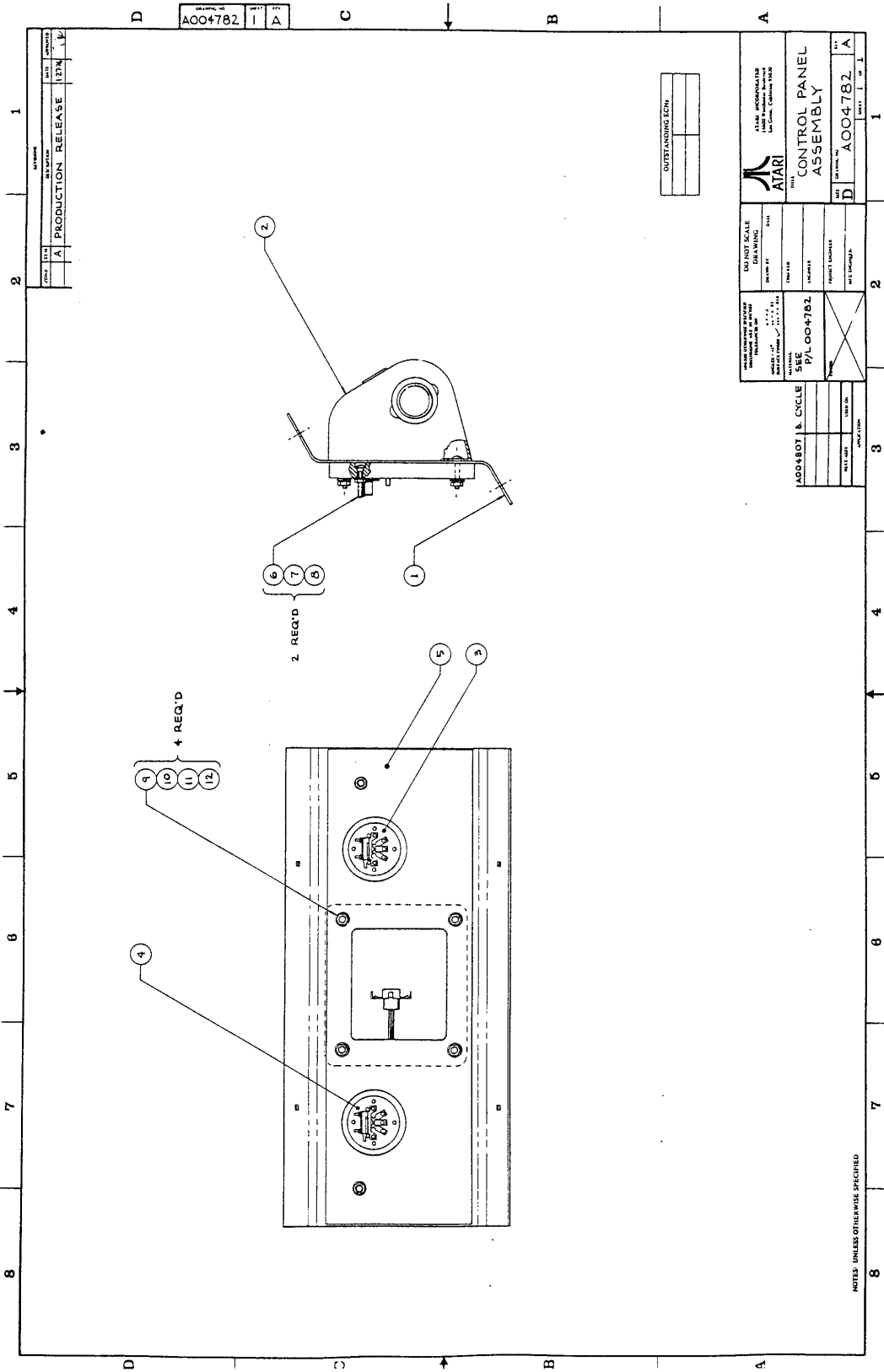

REV.	DATE	DESCRIPTION
1		PRODUCTION RELEASE

PROJECT NO. AOO4782  
 SHEET NO. 1  
 OF 1

OUTSTANDING ECN

<b>CONTROL PANEL ASSEMBLY</b>	
PROJECT NO. AOO4782	
SHEET NO. 1 OF 1	
DO NOT SCALE DRAWING	
SEE P/L OOO4782	
ADD 480T 8. CYCLE	

NOTES: UNLESS OTHERWISE SPECIFIED

STUNT CYCLE

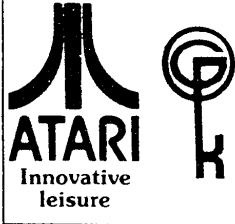

ASSEMBLY TITLE / HANDLEBAR ASSEMBLY P/L003417

PARTS LIST SPECIFICATION Page 1 of 1

Drawn	
Checked	Mech. Eng.
Proj. Eng.	Elec. Eng
	REV. B

Rev.	Description	Date	Apprv.	Rev.	Description	Date	Apprv.
A	PROD REL						
B	Rev per ECN 1881						

Item	Part Number	Qty.	DESCRIPTION
1	A003414	1	Left Handlebar Assembly
2	A004616	1	Potentiometer- Bracket Assembly
3	003416	1	Shaft - Right Handlebar
4	003423	1	Housing - Casting M/C
5	003424	1	Soc. Hd. Cap Screw Modified
6	003425	1	Stop - Rubber
7	75-5520	3	#10-24 x 1 1/4 Long C/Bolt
8	75-040	5	#10 Lockwasher
9	75-911S	3	#10-24 Nut - Std. Pattern
10	75-5156N	2	#10-24 x 3 1/2" Long C/Bolt
11	75-921S	2	#10-24 Nut - Small Pattern
12	75-5548N	1	1/4-20 x 3.0 Long C/Bolt
13	75-045	1	1/4 Lockwasher
14	75-915S	1	1/4-20 Nut - Std. Pattern
15	76-041218	2	Nylon Bearing #12L12-F (Thomson)
16	73-3004	1	E-Ring .750 Dia. Shaft
17	78-3001009	1	Spring, Extension
18	78-40202	2	Handlebar Grip - Black Waffle Style 7/8"
19	004776	2	Spacer
20	76-06122002	1	Thrust Washer (3/4" 1.250 Dia x .060/.063 Thick)

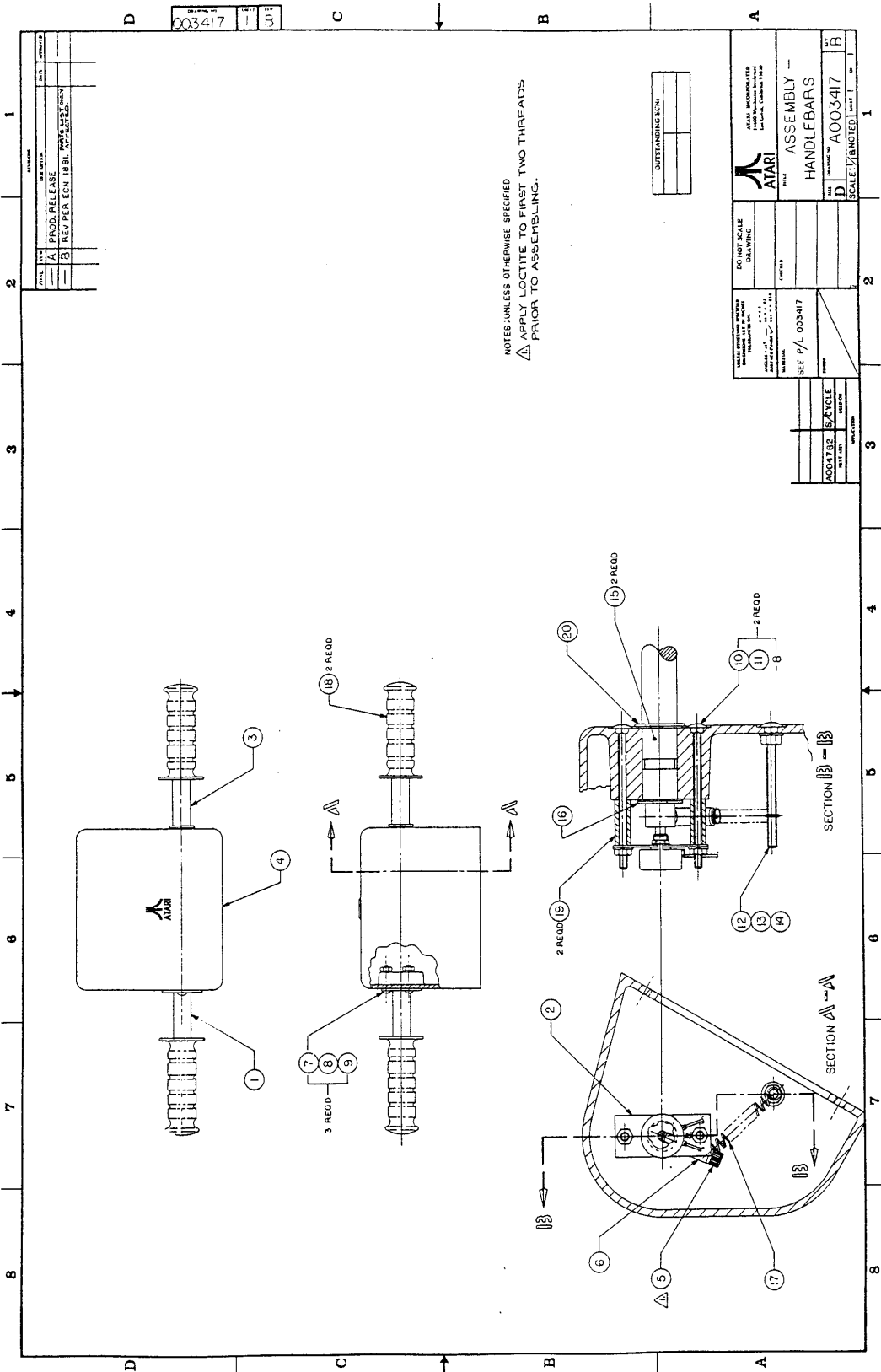

NOTES UNLESS OTHERWISE SPECIFIED  
 △ APPLY LOCITE TO FIRST TWO THREADS  
 PRIOR TO ASSEMBLING.

OUTSTANDING LCN

DO NOT SCALE DRAWING	SEE P/L 003417
ATARI	ASSEMBLY
ATARI CORPORATION	HANDLEBARS
10000 NE ALAMOSA AVE.	REV. 1
REDWOOD CITY, CALIF. 94065	REV. 2
REV. 3	REV. 4
REV. 5	REV. 6
REV. 7	REV. 8
REV. 9	REV. 10
REV. 11	REV. 12
REV. 13	REV. 14
REV. 15	REV. 16
REV. 17	REV. 18
REV. 19	REV. 20
REV. 21	REV. 22
REV. 23	REV. 24
REV. 25	REV. 26
REV. 27	REV. 28
REV. 29	REV. 30
REV. 31	REV. 32
REV. 33	REV. 34
REV. 35	REV. 36
REV. 37	REV. 38
REV. 39	REV. 40
REV. 41	REV. 42
REV. 43	REV. 44
REV. 45	REV. 46
REV. 47	REV. 48
REV. 49	REV. 50
REV. 51	REV. 52
REV. 53	REV. 54
REV. 55	REV. 56
REV. 57	REV. 58
REV. 59	REV. 60
REV. 61	REV. 62
REV. 63	REV. 64
REV. 65	REV. 66
REV. 67	REV. 68
REV. 69	REV. 70
REV. 71	REV. 72
REV. 73	REV. 74
REV. 75	REV. 76
REV. 77	REV. 78
REV. 79	REV. 80
REV. 81	REV. 82
REV. 83	REV. 84
REV. 85	REV. 86
REV. 87	REV. 88
REV. 89	REV. 90
REV. 91	REV. 92
REV. 93	REV. 94
REV. 95	REV. 96
REV. 97	REV. 98
REV. 99	REV. 100

DATE	BY	APP'D	REV.	DESCRIPTION
			A	PROD. RELEASE
			B	REV PER ECH INBL

003417



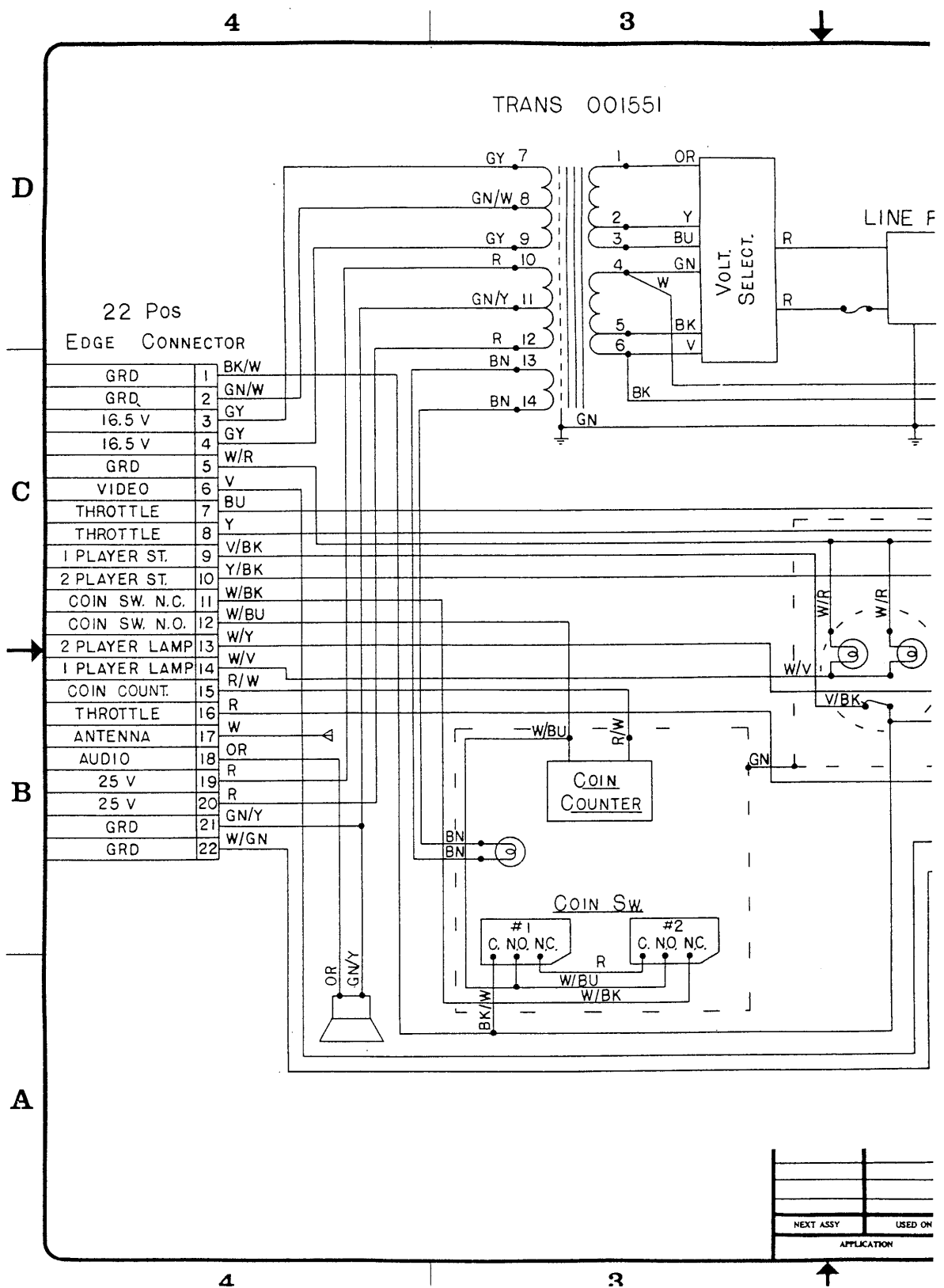

NEXT ASSY	USED ON
APPLICATION	

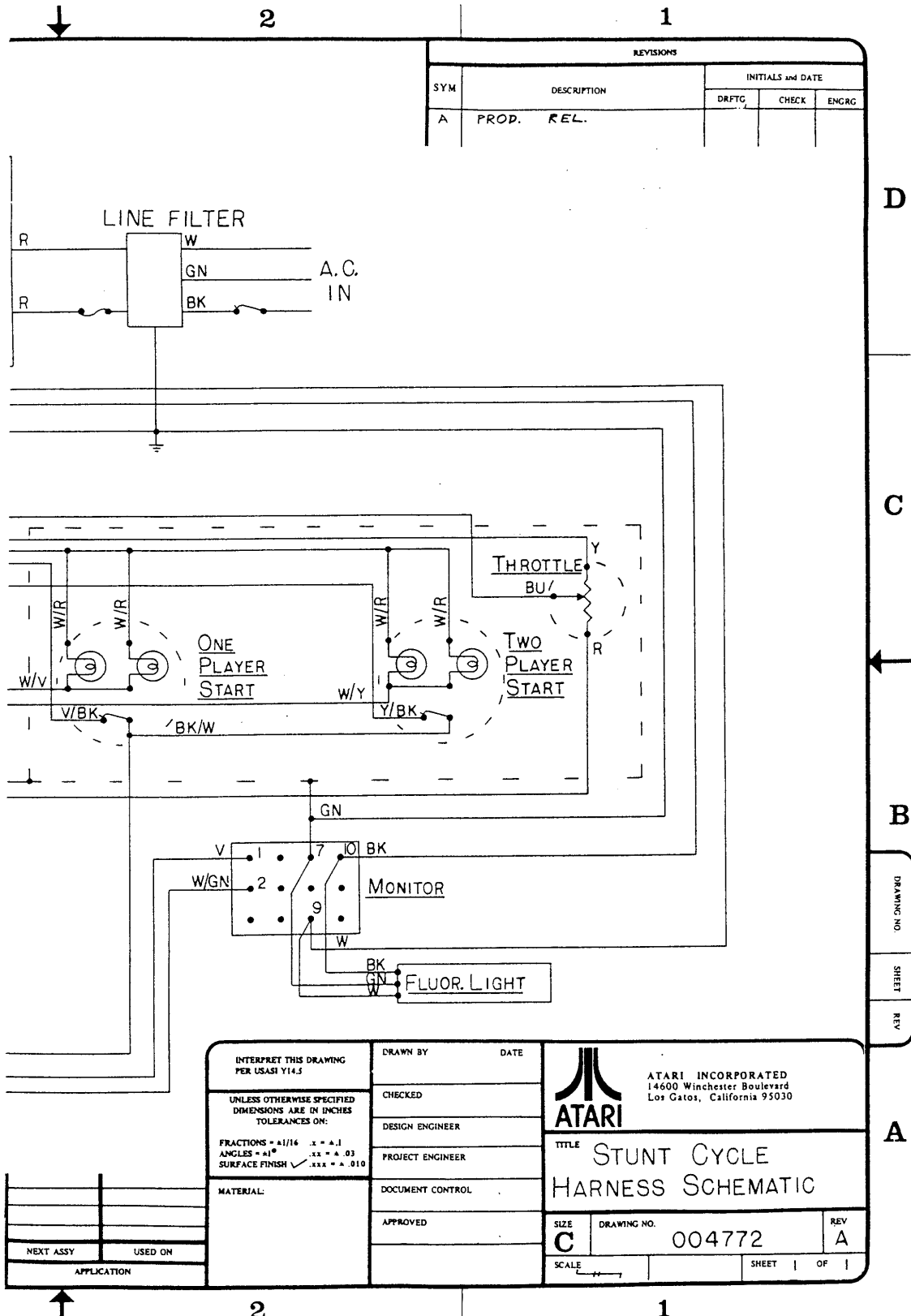

STUNT CYCLE

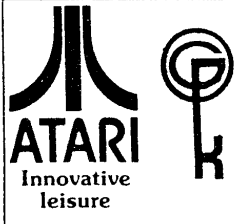

ASSEMBLY TITLE / ASSEMBLY, ELECTRONICS TRAY P/L 004775

PARTS LIST SPECIFICATION Page 1 of 1

Drawn	
Checked	Mech. Eng.
Proj. Eng.	Elec. Eng
	REV. B

Rev.	Description	Date	Apprv.	Rev.	Description	Date	Apprv.
A	PROD REL	1-19-76					
B	REV / ECN 1915	1-22-76					

Item	Part Number	Qty.	DESCRIPTION
1	004068	1	Tray, Electronics
2	001551	1	Transformer
3	72-6608	15	Screw, Sht. Metal, Pan Hd., Phil., #6 x 1/2 Lg.
4	000622	1	Cover, Transformer
5	79-3201	1	Fuse Holder
6	46-201201	1	Fuse, 2 AMP, Slo Blo
7	90-3001	1	Filter, Power Line
8	68-001	1	A.C. Power Interlock Switch
9	000268	1	Bracket, Switch Mtg.
10	A004244	1	Power Cord 8' Assembly
11	A002808-03	1	Interlock Switch Jumper
12	72-6812	4	Screw, SM, Pan Hd., Phil., #8 - 3/4 Lg.
13	A004773-01	1	Harness
14	A001920	1	Harness, Voltage Selection
15	A001921-01	A/R	Shorting Block, 95V
16	A001921-02	"	Shorting Block, 110V
17	A001921-03	"	Shorting Block, 220V H
18	A001921-04	"	Shorting Block, 220V L
19	A003100-04	1	Fuse Jumper Harness
20	000871	1	Label
21	001977	1	Bracket, Speaker
22	48-001	1	Speaker, 8"
23	73-77004	4	3/16 x 5/8" Blind Rivet
24	75-07019	4	Back up Washer

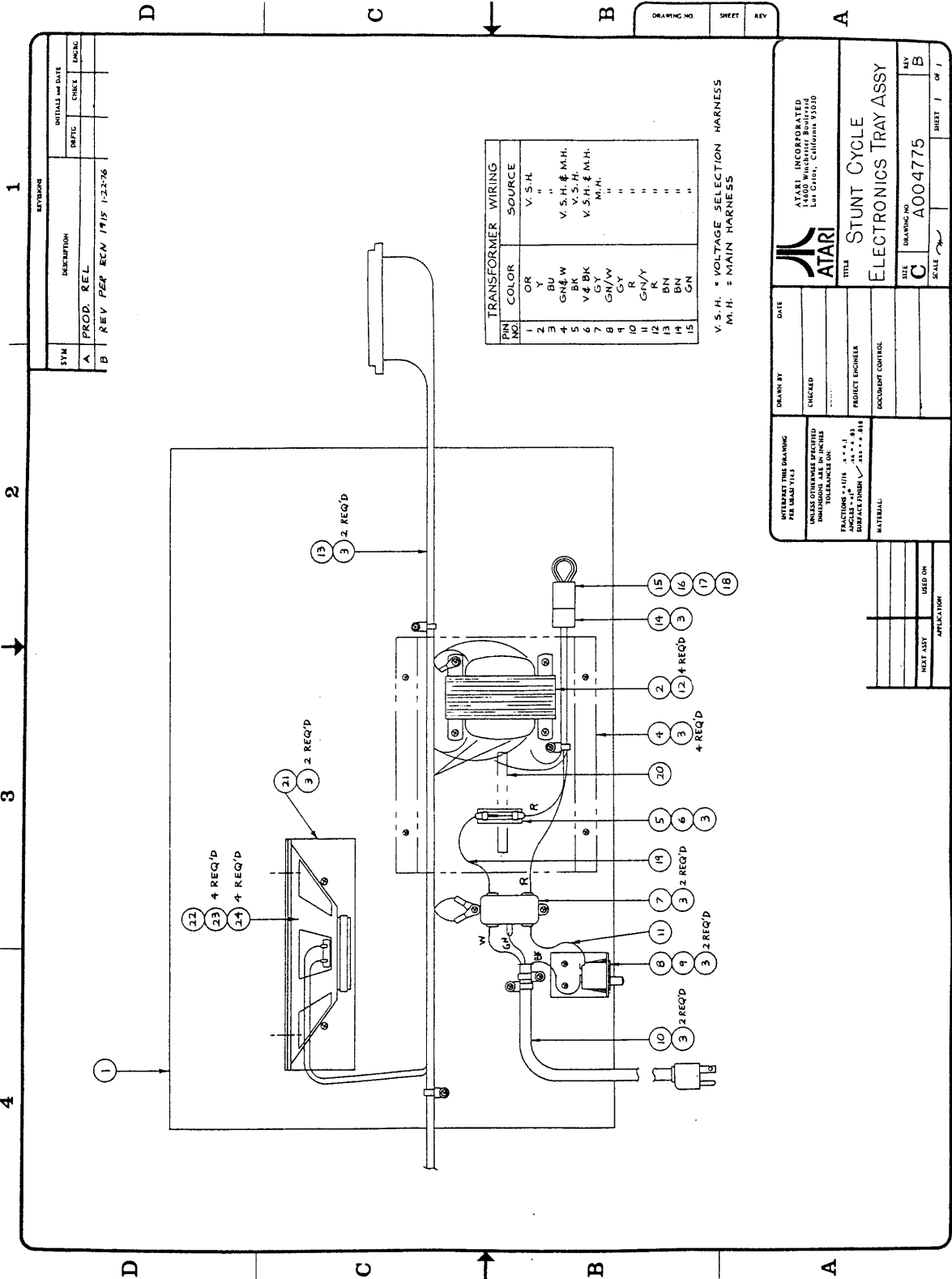

PIN NO.	COLOR	SOURCE
1	OR	V. S.H.
2	Y	"
3	BU	"
4	GN/W	V. S.H. & M.H.
5	BK	V. S.H.
6	GY	V. S.H. & M.H.
7	GY	"
8	GN/W	"
9	GY	"
10	R	"
11	GN/Y	"
12	K	"
13	BN	"
14	GN	"
15	GN	"

V. S. H. = VOLTAGE SELECTION HARNESS  
 M. H. = MAIN HARNESS

SYMBOLS		INITIALS and DATE	
SYMBOL	DESCRIPTION	DATE	CHECK
A	PROD. REL.		
B	REV PER ECN 1715 11-22-76		

		ATARI INCORPORATED 10100 N. DE SOTO AVE. LOS GATOS, CALIFORNIA 95030	
<b>TITLE</b> STUNT CYCLE ELECTRONICS TRAY ASSY			
DATE	DRAWN BY	PROJECT ENGINEER	SCALE
CHECKED		DOCUMENT CONTROL	DRAWING NO.
			A004775
			SHEET 1 OF 1

UNLESS OTHERWISE SPECIFIED DIMENSIONS ARE IN INCHES TOLERANCES ON: FRACTIONS - ± 0.015 DECIMALS - ± 0.005 ANGLES - ± 1° SURFACE FINISH - SEE FIG. 314	MATERIAL:  NEXT ASSEMBLY USED ON: APPLICATION:
---	---

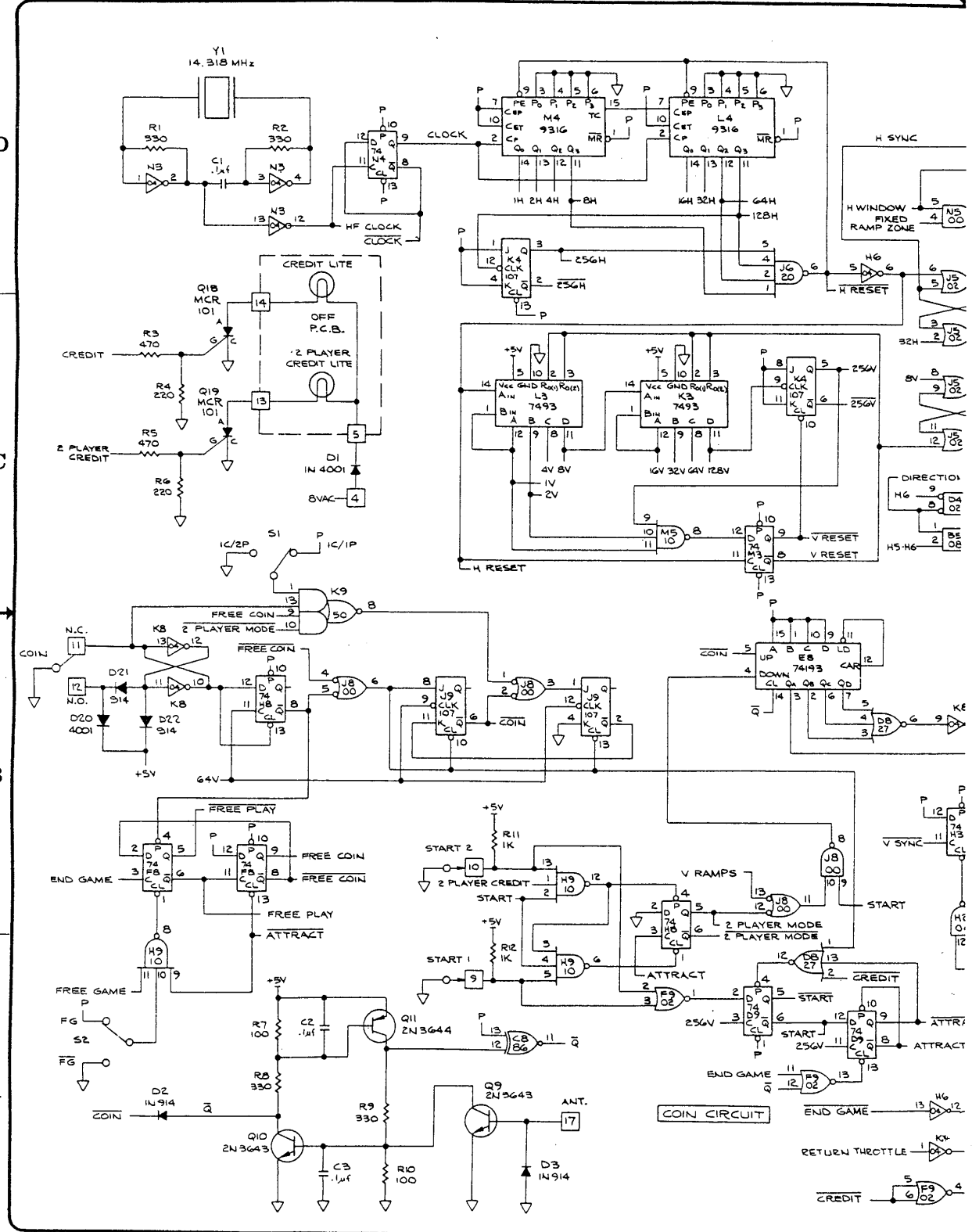

8

7

6

5

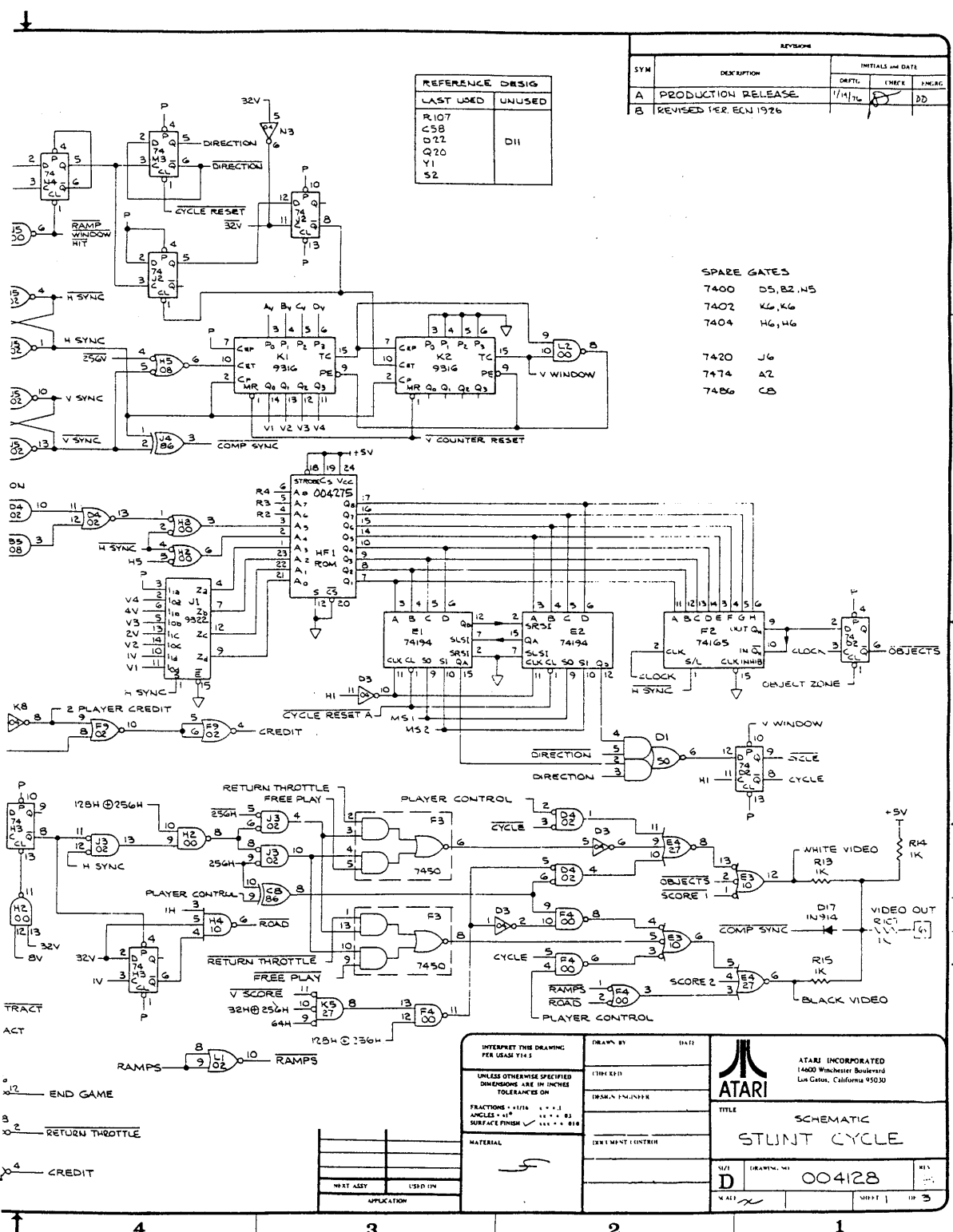

REFERENCE DRISIG	
LAST USED	UNUSED
R107	
C58	
Q12	D11
Q20	
V1	
S2	

REVISION			
SYM	DESCRIPTION	INITIALS AND DATE	
A	PRODUCTION RELEASE	1/1/74	DD
B	REVISED PER ECN 1926		

- SPARE GATES
- 7400 DS, B2, N5
  - 7402 K6, K6
  - 7404 H6, H6
  - 7420 J6
  - 7474 A2
  - 7486 CB

- END GAME
- RETURN THROTTLE
- CREDIT

INTERPRET THIS DRAWING PER USAGE Y14.1 UNLESS OTHERWISE SPECIFIED DIMENSIONS ARE IN INCHES TOLERANCES ON FRACTIONS = +.010 - .005 ANGLES = 18° SURFACE FINISH = .0005 ± .010	DRAWN BY: D143 DATE: 12/1/73 DESIGN ENGINEER:	ATARI INCORPORATED 14600 Monroeville Boulevard Los Gatos, California 95030
MATERIAL:		TITLE: SCHEMATIC STUNT CYCLE
PART ASSY: 1500 1/1 APPLICATION:		SIZE: D DRAWING NO: 004128 REV: 1 SHEET: 1 OF 3

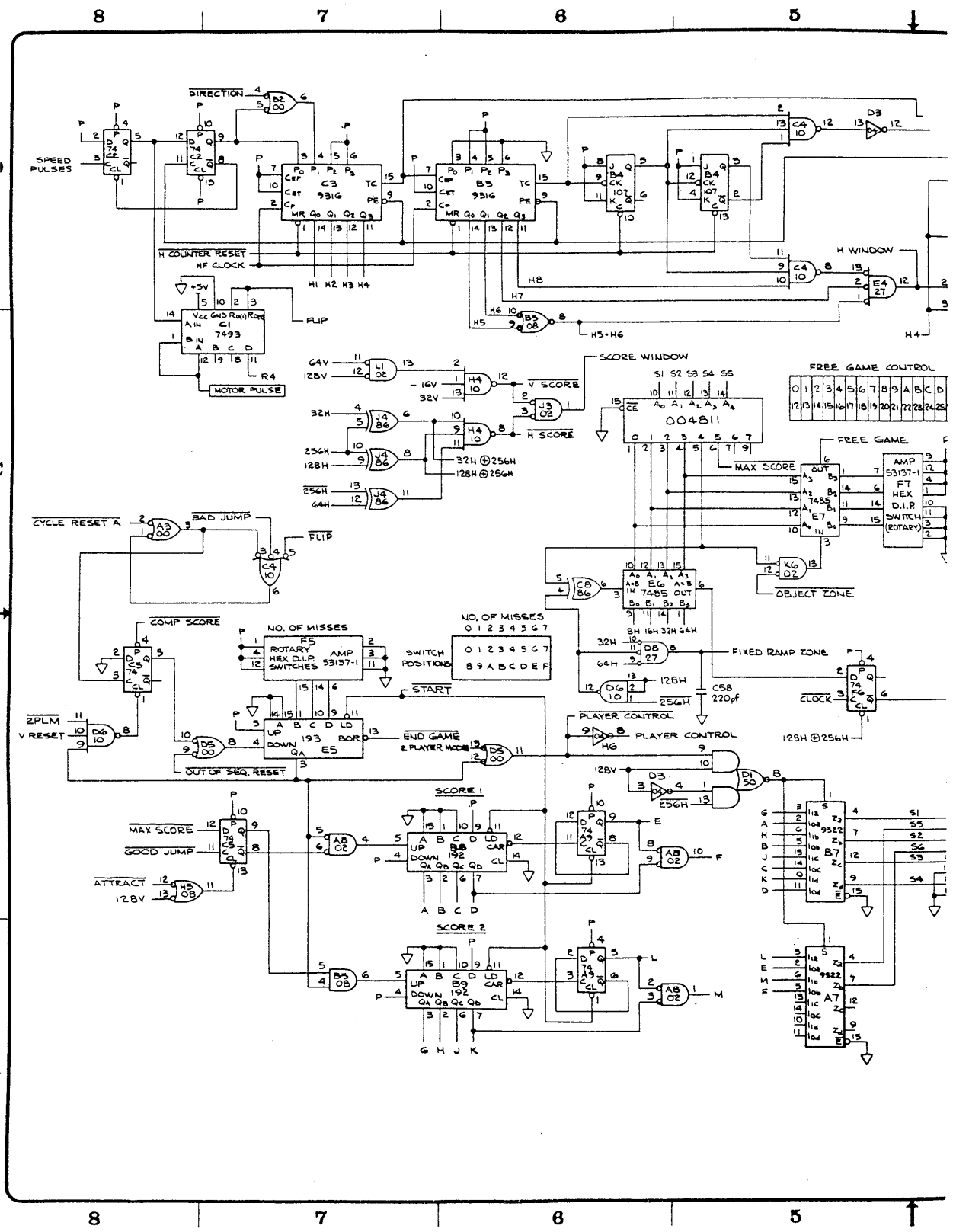

8

7

6

5

8

7

6

5

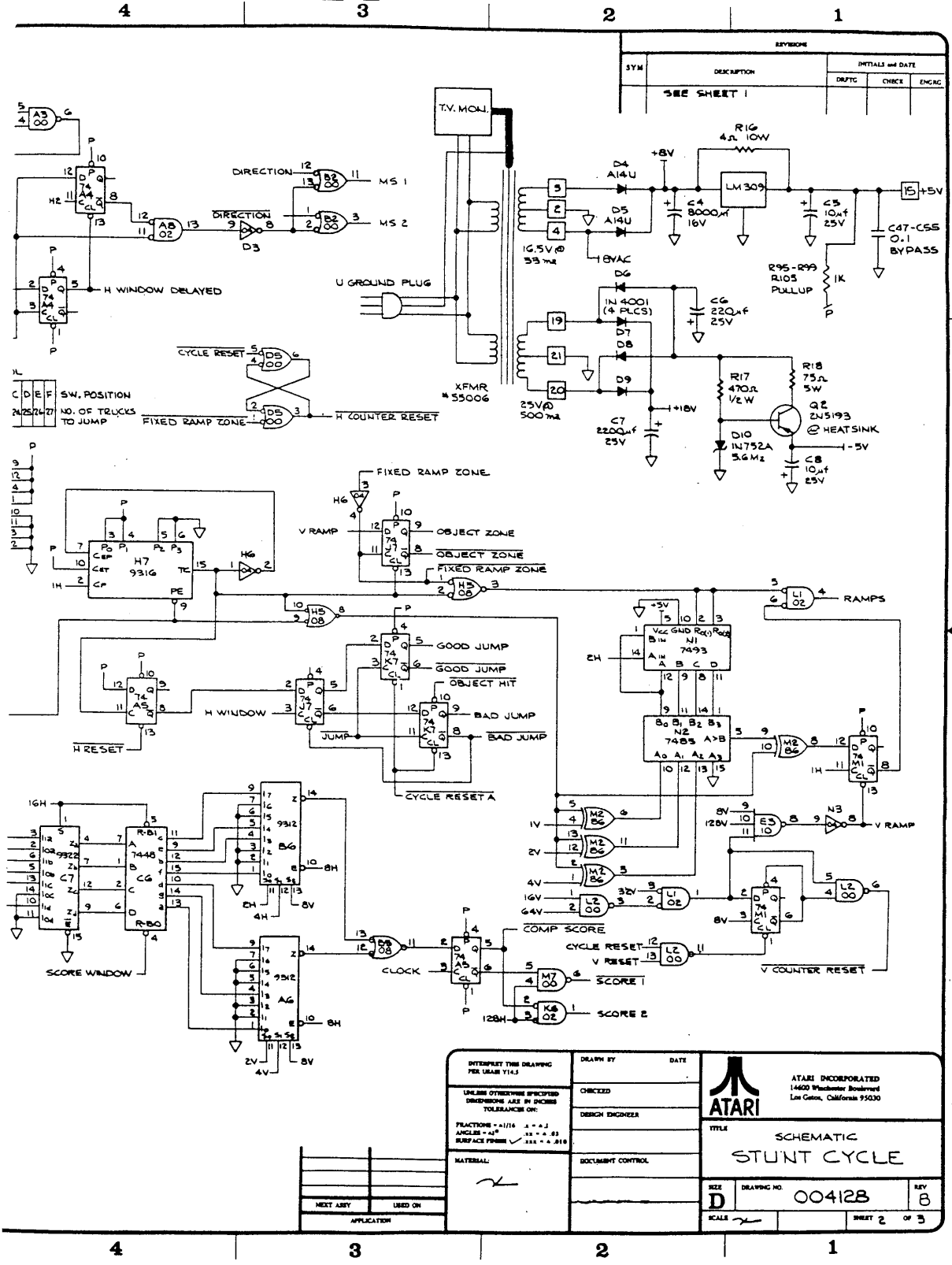

SYMBOL		DESCRIPTION	INITIALS and DATE		
SEE SHEET 1			DRFTC	CHECK	ENGR

SW. POSITION	NO. OF TRUCKS TO JUMP
C	1
D	2
E	3
F	4

INTERPRET THIS DRAWING PER URBAN Y14.3	DRAWN BY	DATE	ATARI INCORPORATED 14600 Washington Boulevard Los Gatos, California 95030
UNLESS OTHERWISE SPECIFIED DIMENSIONS ARE BY DIMENSION TOLERANCES ON:	CHECKED		
FRACTIONS = 1/16 A = ±.1	DESIGN ENGINEER		
ANGLES = 45° .15 ± .01	DOCUMENT CONTROL		
SURFACE FINISH ✓ 32 ± .01			TITLE SCHEMATIC STUNT CYCLE
MATERIAL:			SIZE D
			DRAWING NO. 00412B
			REV B
			SCALE
			SHEET 2 OF 3



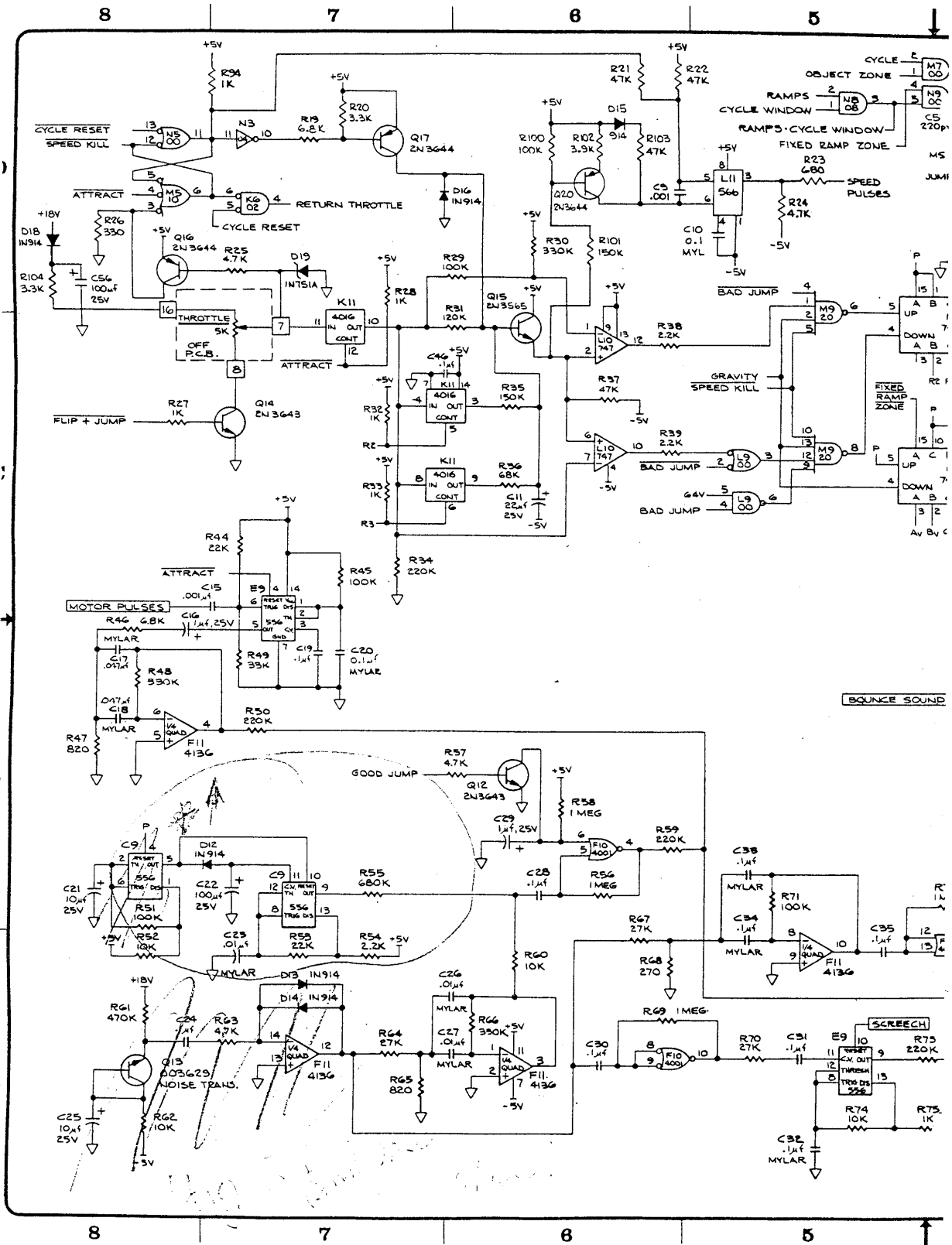

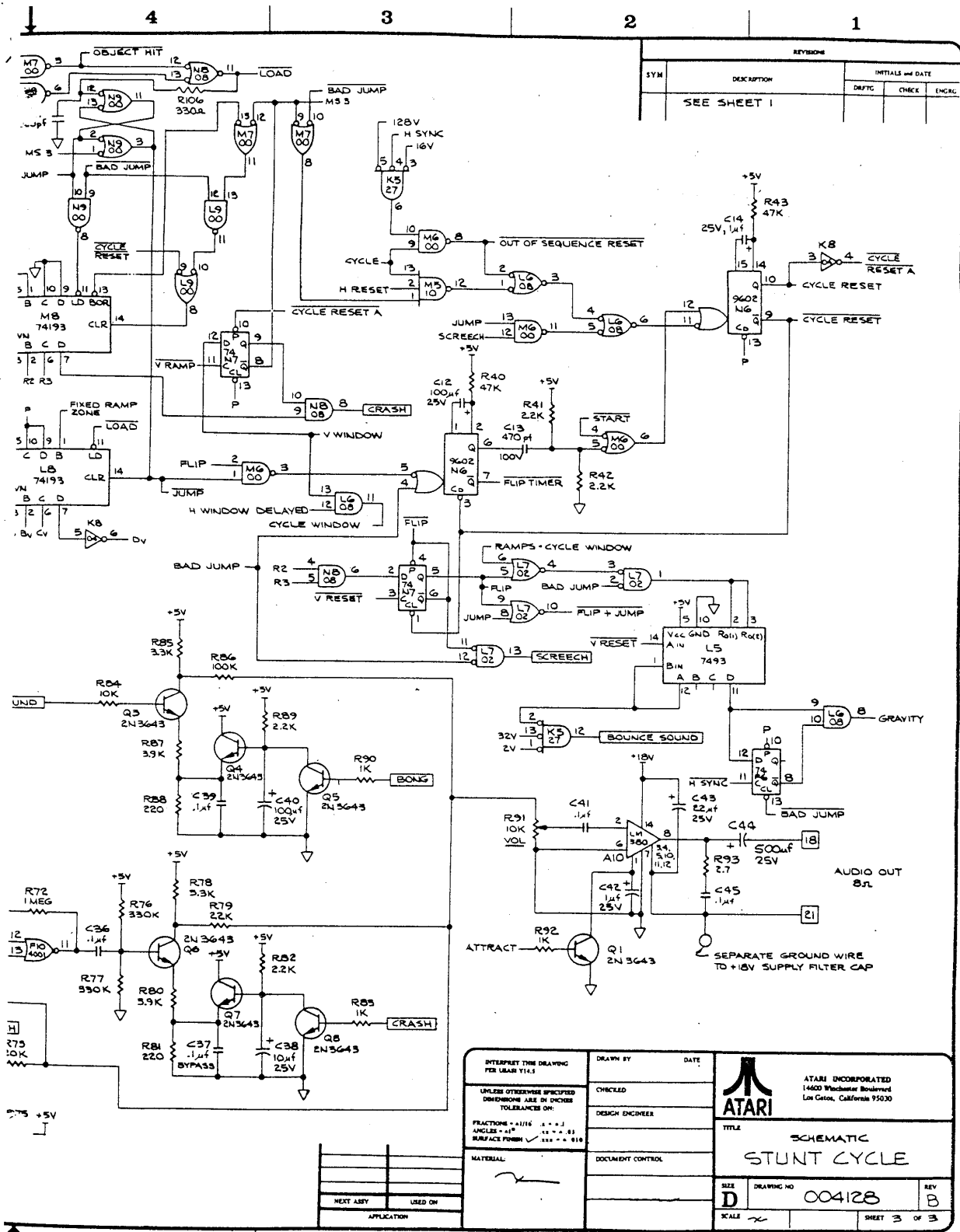

REVISIONS			
SYM	DESCRIPTION	INITIALS AND DATE	
		DRAFT	CHECK
		ENGR	
	SEE SHEET 1		

INTERPRET THIS DRAWING PER UG41-1.1	DRAWN BY	DATE	 ATARI INCORPORATED 1400 Franklin Boulevard Los Gatos, California 95030
UNLESS OTHERWISE SPECIFIED DIMENSIONS ARE IN INCHES TOLERANCES ON:	CHECKED		
FRACTIONS - 1/16 3/32 1/8	DESIGN ENGINEER		TITLE
ANGLES - 45° 90° 135° 180°	DOCUMENT CONTROL		SCHMATIC
MATERIAL:			STUNT CYCLE
			SIZE D DRAWING NO 004128 REV B
			SCALE SHEET 3 OF 3

STUNT CYCLE



ASSEMBLY TITLE	STUNT CYCLE P.C. ASSY.	P/LA004128
----------------	------------------------	------------

PARTS LIST SPECIFICATION	Page 1 of 3
--------------------------	-------------

Drawn Mike Steele	
Checked	Mech. Eng.
Proj. Eng.	Elec. Eng
	REV. B

Rev.	Description	Date	Apprv.	Rev.	Description	Date	Apprv.
A	PROD. REL.	1/19/76					
B							

Item	Part Number	Qty.	DESCRIPTION				
1	004129	1	Printed Circuit Board				
2	10-5101	2	Res., Carbon, 5%, 1/4W, 100 ohm R7,10				
3	10-5102	21	" " " " 1K ohm R11,12,13,15,27,28, R32,33,75,83,90,92, R14,94,95,96,97,98, 99, 105,107				
4	10-5103	5	" " " " 10K ohm R52,60,62,74,84				
5	10-5104	6	" " " " 100K ohm R29,45,51,71,86,100				
6	10-5105	4	" " " " 1Meg ohm R56,58,69,72				
7	10-5124	1	" " " " 120K ohm R31				
8	10-5154	2	" " " " 150K ohm R35, 101				
9							
10	10-5221	4	" " " " 220 ohm R4,6,81,88				
11	10-5222	7	" " " " 2.2K ohm R38,39,41,42,82, R89,54				
12	10-5223	3	" " " " 22K ohm R44,79,53				
13	10-5224	4	" " " " 220K ohm R34,50,59,73				
14	10-52P7	1	" " " " 2.7 ohm R93				
15	10-5271	1	" " " " 270 ohm R68				
16	10-5273	3	" " " " 27K ohm R64,67,70				
17	10-5331	6	" " " " 330 ohm R1,2,8,9,26,106				
18	10-5332	4	" " " " 3.3K ohm R78,85,20,104				
19	10-5333	1	" " " " 33K ohm R49				
20	10-5334	5	" " " " 330K ohm R30,48,66,76,77				
21	10-5392	3	" " " " 3.9K ohm R80,87,102				
22	10-5471	2	" " " " 470 ohm R3,5				
23	10-5472	4	" " " " 4.7K ohm R24,25,57,63				
24	10-5473	6	" " " " 47K ohm R37,40,43,21,22,103				
25	10-5474	1	" " " " 470K ohm R61				
26	10-5681	1	" " " " 680 ohm R23				
27	10-5682	2	" " " " 6.8K ohm R46,19				
28	10-5683	1	" " " " 68K ohm R36				
29	10-5684	1	" " " " 680K ohm R55				
30	10-5821	2	" " " " 820 ohm R47,65				
31							
32	11-5471	1	" " " 1/2W 470 ohm R17				

## PARTS LIST SPECIFICATION

Page 2 of 3

Item	Part Number	Qty.	DESCRIPTION	
33	16-5750	1	Res., Carbon, 5%, 5W, 75 ohm	R18
34	19-805W4p0	1	Res., Carbon, 5%, 10W, 4 ohm	R16
35	19-315103	1	Trimpot, 10K	R91
36				
37	21-101104	5	Cap., Mylar, .1uf	C32,33,34,10,20
38	21-101473	2	" " .047uf	C17,18
39	21-101103	3	" " .01uf	C26,27,23
40	24-250507	1	Cap., Electrolytic, 500uf, 25V	C44
41	24-250105	4	" " 1uf, 25V	C14,16,29,42
42	24-250106	5	" " 10uf, 25V	C5,8,21,25,38
43	24-250107	4	" " 100uf, 25V	C12,22,40,56
44	24-250226	2	" " 22uf, 25V	C11,43
45	24-250227	1	" " 220uf, 25V	C6
46	24-250228	1	" " 2200uf, 25V	C7
47	24-160808	1	" " 8000uf, 16V	C4
48	27-250102	2	Cap., Ceramic Disc, .001uf, 25V	C15,9
49	27-250104	24	" " .1uf, 25V	C1,2,3,19, 24,28, C30,31,35,36,37,39, C41,45,46,47,48,49, 50,51,52,53,54,55
50	28-101221	2	Cap., Dipped Mica, 220pf, 100V	C57,58
51	28-101471	1	Cap., Dipped Mica, 470pf, 100V	C13
52	31-A14U	2	Diode, A14U	D4,5
53	31-1N914	11	Diode, 1N914	D2,3,12,13,14,15, D16,17,18,21,22
54	31-1N4001	6	Diode, 1N4001	D1,6,7,8,9,20
55	32-1N752A	1	Diode, Zener, 1N752A	D10
56	33-2N3644	4	Transistor, 2N3644	Q11,16,17,20
57	34-2N3643	11	Transistor, 2N3643	Q10,9, 14, 12, Q3,4,5,6,7,8,1
58	33-2N5193	1	Transistor, 2N5193	Q2
59	35-MCR101	2	Transistor, MCR101	Q18,19
60	37-7400	12	Integrated Circuit, 7400	N5,L2,H2,A3,B2,D5, J8, M7,L9,N9, M6,F4
61	37-7404	4	" " 7404	N3,H6,D3,K8
62	37-7402	8	" " 7402	J5,D4,A8,L1,J3,K6, L7,F9
63	37-7408	4	" " 7408	B5,H5,N8,L6
64	37-7410	6	" " 7410	M5,C4,D6,H4,E3,H9
65	37-7420	2	" " 7420	J6, M9
66	37-7427	3	" " 7427	E4,K5,D8
67	37-7448	1	" " 7448	C6
68	37-7450	3	" " 7450	D1,K9,F3

## PARTS LIST SPECIFICATION

Page 3 of 3

Item	Part Number	Qty.	DESCRIPTION	
69	37-7474	18	Integrated Circuit, 7474	N4,M3,J2,D2,C2,C5, A4,H8,D9,A9,F6,J7, K7,A5,M1,N7,F8,H3
70	37-7485	3	"	E6,E7,N2
71	37-7486	3	"	J4,C8,M2
72	37-7493	5	"	L3,K3,C1,N1,L5
73	37-74107	3	"	K4,B4, J9
74	37-74165	1	"	F2
75	37-74192	2	"	B8,B9
76	37-74193	4	"	E5,L8,M8,E8
77	37-74194	2	"	E1,E2
78	37-9312	2	"	A6,B6
79	37-9316	7	"	M4,L4,K1,K2,C3,B3, H7
80	37-9322	4	"	J1,A7,B7,C7
81	37-9602	1	"	N6
82	37-556	2	"	E9,C9
83	37-566	1	"	L11
84	37-747	1	"	L10
85	37-4001	1	"	F10
86	37-4016	1	"	K11
87	37-4136	1	"	F11
88	37-LM380	1	"	A10
89				
90				
91	37-LM309K	1	Regulator, LM309K	
92	69-001	2	Switch, Slide, DPDT	S1,S2
93	72-1406C	1	Screw, Pan Hd, Phil, 4-40 x 3/8" Lg CRES	
94	72-1608C	2	Screw, Pan Hd, Phil, 6-32 x 1/2" Lg CRES	
95	75-016S	2	Washer, Flat, Reg Pattern, #6, STEEL	
96	75-054	1	Washer, Lock, Int. Star, #4	
97	75-056	2	Washer, Lock, Int. Star, #6	
98	75-914C	1	Nut, Hex, #4-40, CRES	
99	75-916C	2	Nut, Hex, #6-32, CRES	
100	78-06001	1	Heatsink,	
101				
102				
103	90-101	1	Crystal, 14.31818mhz	Y1
104	34-2N3565	1	Transistor, 2N3565	Q15
105	32-1N751A	1	Diode, Zener, 1N751A	D19
106	66-014P2T	2	Switch, Rotary Hex	F5,F7
107	78-16005	1	Silpad	
108	004275	1	ROM, Motorcycle & Bus	HF1
109	004811	1	ROM, Score Translator	D7
110	003629	1	Transistor noise source	Q13

8

7

6

5

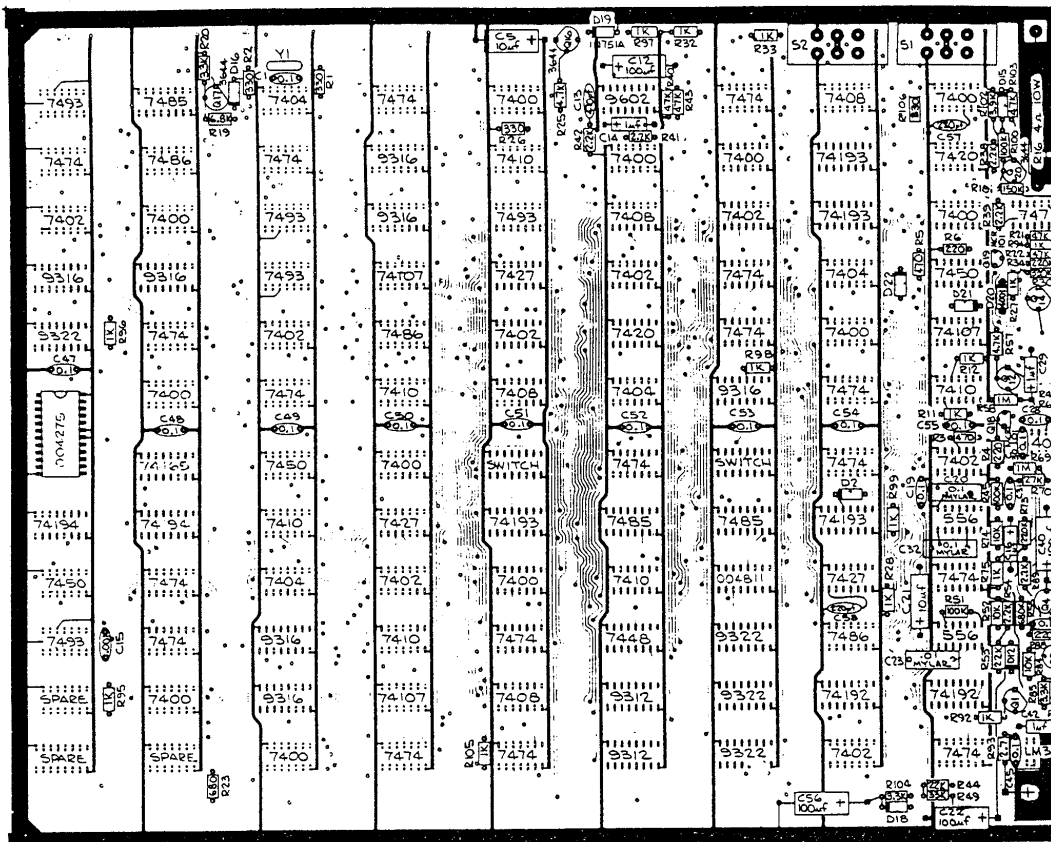

8

7

6

5

4 3 2 1

REVISIONS				
SYM	DESCRIPTION	INITIALS AND DATE		
		DESIGN	CHECK	ENGR.
A	PRODUCTION RELEASE	1/19/76	[Signature]	[Signature]
B	REVISED PER ECN 926			

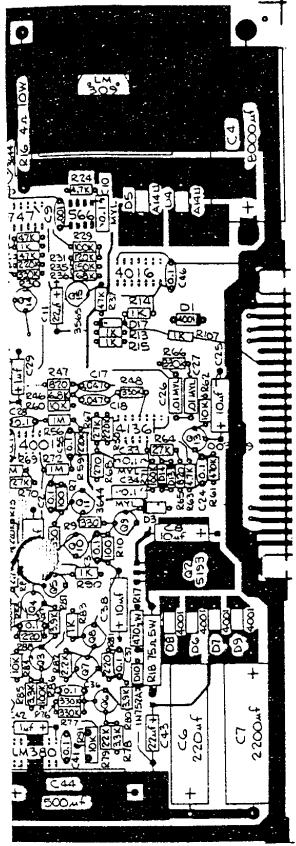

- NOTES:
1. ALL UNMARKED TRANSISTORS ARE 2N3643.
  2. ALL UNMARKED DIODES ARE 1N914.

- MODIFICATIONS TO REVISION "C" PC BOARD 004129:
1. CUT TRACE TO CATHODE OF D22 (1N914) ON CIRCUIT SIDE OF BOARD.
  2. JUMPER CATHODE OF D22 TO +5V BUSS.
  3. CUT TRACE TO PIN 2 OF M2 ON COMPONENT SIDE OF BOARD.
  4. JUMPER PIN 2 OF M2 TO PIN 8 OF H5.
  5. JUMPER PIN 9 OF H5 TO PIN 15 OF H7.
  6. JUMPER PIN 10 OF H5 TO PIN 9 OF H7.
  7. CUT BASE PAD OF Q20 ON CIRCUIT SIDE (SHORTED TO TRACE).
  8. CUT TRACE FROM CATHODE OF D19 TO BASE OF Q16 ON CIRCUIT SIDE.
  9. JUMPER CATHODE OF D19 TO END OF R25 (4.7K) NOT CONNECTED TO Q16.
  10. CUT TRACE RUNNING BETWEEN PINS 4 & 5 OF L6 TO PIN 11 OF L6.
  11. CUT TRACE TO PIN 1 OF N8 ON CIRCUIT SIDE OF BOARD.
  12. JUMPER PIN 1 OF N8 TO PIN 11 OF L6.
  13. CUT AND LIFT PIN 1 OF F6.
  14. JUMPER LIFTED PIN 1 OF F6 TO PIN 8 OF J4.
  15. CUT TRACE BETWEEN TWO FEEDTHROUS (BEHIND PIN 8 OF N9). TRACE RUNS TO PIN 12 OF N9.
  16. INSTALL A 330Ω RESISTOR INTO THE TWO FEEDTHRU HOLES.
  17. INSTALL A 220pF CAPACITOR FROM PIN 12 OF N9 TO GROUND BUSS.
  18. CUT TRACE TO CONNECTOR PIN 6 ON CIRCUIT SIDE OF BOARD.
  19. INSTALL A 1K RESISTOR FROM ANODE OF D17 TO CONNECTOR PIN 6 ON COMPONENT SIDE OF BOARD.
  20. CHANGE C20 (0.1 CERAMIC) BETWEEN E9 & F9 TO A 0.1 MYLAR (21-101104).
  21. INSTALL A 220pF CAPACITOR FROM PIN 8 OF D6 TO GROUND BUSS.

	STUNT CYCLE
NEXT ASSY	SECTION
OPERATION	

INTERPRET THIS DRAWING PER UNAS 514.5	DESIGNED BY	DATE	 ATARI INCORPORATED 14400 Winchester Boulevard Los Gatos, California 95030
UNLESS OTHERWISE SPECIFIED DIMENSIONS ARE IN INCHES TO 3 DECIMALS	DRAWN BY		
FRACTIONS 1/16 1/8 1/4 3/8 1/2 5/8 3/4 7/8	CHECKED BY		
DECIMALS .125 .25 .375 .5 .625 .75 .875	DATE		
MATERIAL	TOLERANCE CONTROL		TITLE <b>ASSEMBLY,          STUNT CYCLE</b>
	SIZE	DRAWING NO.	REV.
	D	4004128	B

4 3 2 1

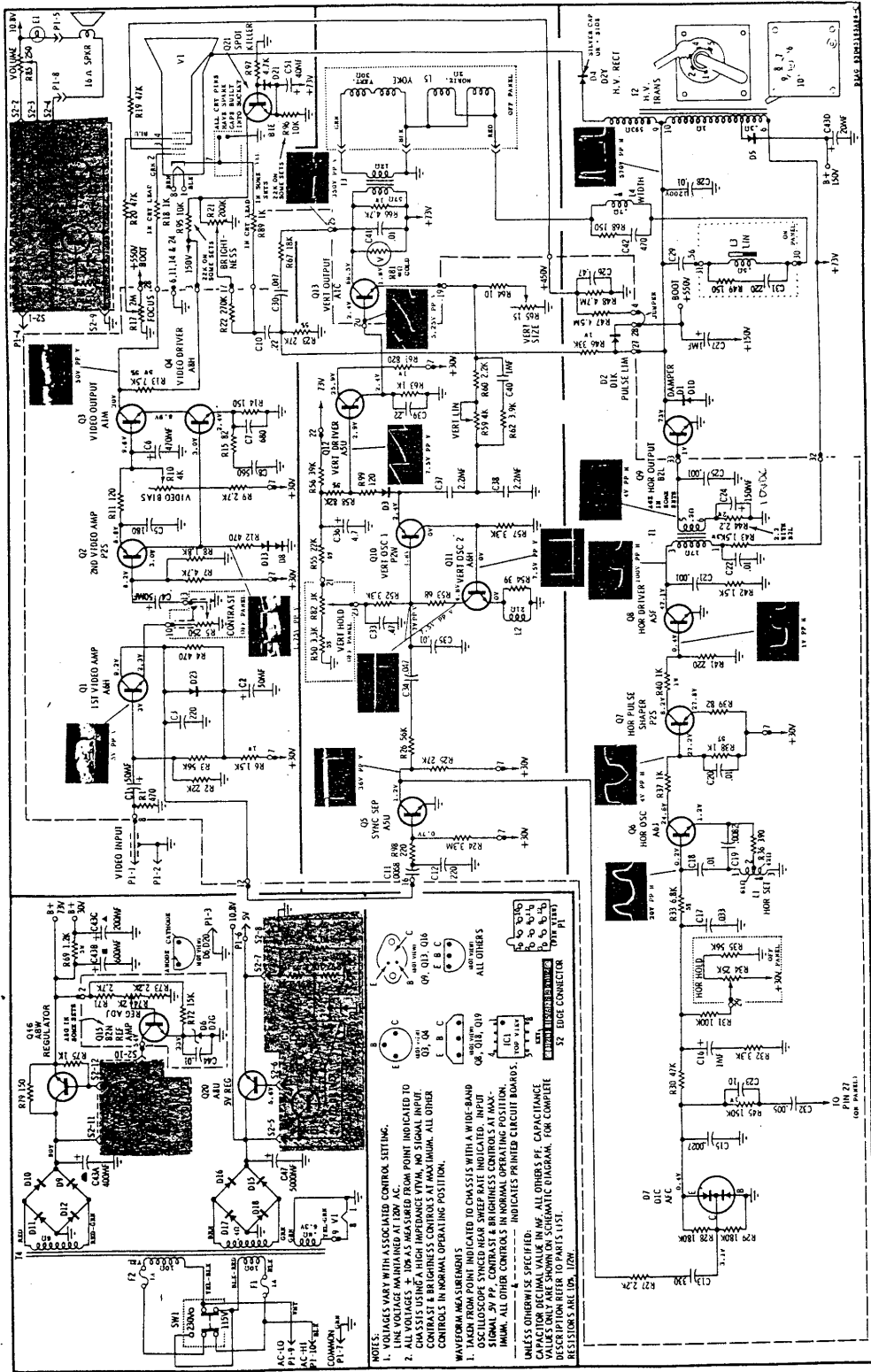

Schematic, Motorola XM501/XM701 Monitor  
 XM501-10 Not XM501-10B



