

SEGA[®]

SEGA CORPORATION
Nissay Aroma Building, 5-37-1, Kamata, Ohta-ku, Tokyo 144-8721, Japan
Phone: +81-3-5480-6582 Facsimile: +81-3-5480-6584

© SEGA CORPORATION, 2005

1ST PRINTING

MANUAL NO. 420-6805-02

DINOSAUR KING
OWNER'S MANUAL

MANUAL NO. 420-6805-02

SEGA[®]



OWNER'S MANUAL



- Before using this product, read this MANUAL carefully to understand the contents herein stated.
- After reading this manual, be sure to keep it available nearby the product or elsewhere convenient for referring to it anytime when necessary.

SEGA CORPORATION

TABLE OF CONTENTS

BEFORE USING THE PRODUCT, BE SURE TO READ THE FOLLOWING:

TABLE OF CONTENTS

INTRODUCTION

1. HANDLING PRECAUTIONS	1
2. PRECAUTIONS REGARDING INSTALLATION LOCATION	3
2 – 1 LIMITATIONS OF USAGE	3
2 – 2 OPERATION AREA	4
3. PRECAUTIONS REGARDING PRODUCT OPERATION	5
3 – 1 BEFORE OPERATION	5
3 – 2 DURING OPERATION (PAYING ATTENTION TO CUSTOMERS)	6
4. PART DESCRIPTIONS	7
5. ACCESSORIES	8
6. ASSEMBLY AND INSTALLATION	9
7. MANAGEMENT CHIP AND DINOSAUR KING CARDS	17
7 – 1 INSTALLING MANAGEMENT CHIP	17
7 – 2 MANAGEMENT CHIP ERROR CODES	19
7 – 3 REFILLING CARDS	21
7 – 4 DEALING WITH JAMMED CARDS	23
8. PRECAUTIONS WHEN MOVING THE MACHINE	26
9. GAME DESCRIPTION	27
10. SystemSP BOARD	31
10 – 1 EXTERNAL VIEW	31
10 – 2 MONITOR PLACEMENT AND HORIZONTAL SCANNING FREQUENCY	32
10 – 3 ERROR MESSAGES	33
10 – 4 REMOVING THE BOOT ROM	35
10 – 5 REMOVING THE LITHIUM BATTERY	36
10 – 6 INSERTION/REMOVAL OF THE LITHIUM BATTERY	37
10 – 7 SOFTWARE UPGRADE	38
10 – 8 KEY CHIP	40
11. EXPLANATION OF TEST AND DATA DISPLAY	41
11 – 1 MAINTENANCE SWITCH UNIT AND COIN METER	42
11 – 2 COIN/CREDIT ASSIGNMENTS	43
11 – 3 SYSTEM TEST MODE	44
11 – 4 GAME TEST MODE	59
12. CARD DISPENSER	67
13. CARD READER (CONTROL PANEL)	68
13 – 1 HOW TO CLEAN THE CARD READER	68
13 – 2 HOW TO REMOVE THE CARD READER (METALLIC TYPE)	69
13 – 2 HOW TO REMOVE THE CARD READER (MOLDED TYPE)	71
14. POWER UNIT	73
14 – 1 HOW TO REMOVE THE POWER UNIT	73
14 – 2 COMPOSITION OF THE POWER UNIT	74
15. COIN SELECTOR AND BILL ACCEPTOR	75
16. MONITOR	77
16 – 1 CAUTIONS/WARNINGS REGARDING SAFETY FOR HANDLING THE MONITOR	77
16 – 2 CLEANING THE CRT SURFACES AND THE MONITOR COVER	78
16 – 3 MONITOR ADJUSTMENT	79
17. PERIODIC INSPECTION	81
18. TROUBLESHOOTING	82
19. GAME BOARD	84
19 – 1 REMOVING THE GAME BOARD	84
19 – 2 COMPOSITION OF THE GAME BOARD	86
20. DESIGN-RELATED PARTS	87
21. PARTS LIST	88
22. WIRE COLOR CODE TABLE	118
23. WIRING DIAGRAM	119

1

2

3

4

5

6

7

8

9

10

11

12

13

14

15

16

17

18

19

20

21

22

23

INTRODUCTION

This manual is intended to provide detailed descriptions together with all the necessary information covering the general operation of electronic assemblies, electro-mechanicals, servicing control, spare parts, etc. for the product, "**Dinosaur King.**"

This manual is intended for the owners, personnel and managers in charge of operation of the product.

Operate the product after carefully reading and sufficiently understanding the instructions.

In the unlikely event that the product does not function correctly, DO NOT allow anyone other than a technician to touch the internal system. Turn off the power to the machine, making sure to unplug the electrical cord from the outlet, and contact the office listed below or the point-of-purchase for this product.

Use of this product is unlikely to cause physical injuries or damage to property. However, points that require special attention are indicated by thick underlining, the word "IMPORTANT" and the symbol below.



Indicates important information that, if ignored, may result in the mishandling of the product and cause faulty operation or damage to the product.

IMPORTANT

SEGA AMUSEMENTS U.S.A., INC.

901 Cambridge Drive, Elk Grove Village, IL 60007, U.S.A.

TEL: (847) 364-9787

TOLL FREE: (888) 877-2669

FAX: (847) 439-7968

SPECIFICATIONS

Installation space:	719 mm (28.3 in.) [Width] × 730 mm (28.7 in.) [Depth]
Height [POP assembled]:	1,290 mm (50.8 in.); [1,618 mm (63.7 in.)]
Weight:	94 kg (207.2 lbs.)
Power, maximum current:	86 W, 1.1 A (AC 120 V, 60 Hz Area)
Card capacity:	600 (Max.)
Monitor:	14 Type Color Monitor

Definition of 'Site Maintenance Personnel or Other Qualified Individuals'



Procedures not described in this manual or marked as 'to be carried out by site maintenance personnel or other qualified professionals' should not be carried out by personnel without the necessary skill or technology. Work carried out by unqualified persons may cause serious accidents, including electrocution.

Parts replacement, maintenance inspections and troubleshooting should be carried out by site maintenance personnel or other qualified professionals. This manual includes directions that potentially dangerous procedures should only be carried out by professionals with the appropriate specialized knowledge.

The 'site maintenance personnel or other qualified professionals' mentioned in this manual are defined as follows:

Site maintenance personnel:

Individuals with experience in maintaining amusement equipment, vending machines, etc., working under the supervision of the owner/operator of this product to maintain machines within amusement facilities or similar premises by carrying out everyday procedures such as assembly, maintenance inspections, and replacement of units/ expendable parts.

Activities to be carried out by site maintenance personnel:

Amusement equipment/vending machine assembly, maintenance inspection and replacement of units/ expendable parts.

Other qualified professionals:

Persons employed by amusement equipment manufacturers, or involved in design, production, testing or maintenance of amusement equipment. The individual should have either graduated from technical school or hold similar qualifications in electrician/electronics/mechanical engineering.

Activities to be carried out by other qualified professionals:

Amusement equipment/vending machine assembly, repair/adjustment of electrical/electronic/mechanical parts.

1. HANDLING PRECAUTIONS

When installing or inspecting the machine, be very careful of the following points and pay attention to ensure that the player can enjoy the game safely.

Non-compliance with the following points or inappropriate handling running counter to the cautionary matters herein stated can cause personal injury or damage to the machine.



- Before performing work, be sure to turn power off. Performing the work without turning the power off can cause electric shocks or short circuits. In the case that work should be performed with the power ON, this will be clearly stated in the manual.
- To avoid electric shocks and short circuits, do not plug in or unplug the machine too quickly.
- To avoid electric shocks, do not plug in or unplug the machine with wet hands.
- Do not leave power cords and earth wires exposed on the surface (floor, passage, etc.). If exposed, the power cords and earth wires are susceptible to damage. Damaged cords and wires can cause electric shocks or short circuits.
- To avoid causing a fire or electric shock, do not put things on or damage power cords.
- During or after installation of the product, do not unnecessarily pull the power cord. If damaged, the power cord can cause a fire or electric shock.
- In case the power cord is damaged, ask for replacement from the point-of-purchase or the office herein stated. Using a damaged cord can cause fire, electric shock or leakage.
- Be sure to perform grounding appropriately. Inappropriate grounding can cause electric shocks.
- Be sure to use fuses meeting the specified rating. Using fuses exceeding the specified rating can cause a fire or electric shock.
- Ensure that connectors for IC BD and others are properly inserted. Insufficient insertion can cause an electric shock.
- Specification changes, removal of equipment, conversion and/or additions not designated by SEGA are not permitted.
 - Failure to observe this may cause a fire or an electric shock. Non-compliance with this instruction can have a bad influence upon the physical condition of the players or the onlookers, or result in injury during play.
 - SEGA shall not be held responsible for damage, or compensation for damage to a third party, caused by specification changes not designated by SEGA.
- Be sure to perform the periodic maintenance inspections herein stated.



- For the IC board circuit inspections, only the logic tester is allowed. The use of a multiple-purpose tester is not permitted, so be careful in this regard.
- When cleaning the CRT surfaces, use a soft and dry cloth. Do not apply chemicals such as thinner, benzene, etc.
- Static electricity from your body may damage some electronics devices on the IC board. Before handling the IC board, touch a grounded metallic surface so that the static electricity can be discharged.
- Do not turn the power on and off continuously. Repeatedly turning the power on and off may cause product malfunction or parts damage.
- Some parts are not specifically designed and manufactured for this game machine. The manufacturers may discontinue, or change the specifications of, such general-purpose parts. If this is the case, SEGA cannot repair or replace the damaged game machine, whether or not the warranty period has expired.

CONCERNING THE STICKER DISPLAY

This SEGA product has stickers attached describing the product manufacture No. (Serial No.) and Electrical Specifications. It also has a Sticker describing where to contact for repair and for purchasing parts.

When inquiring about or asking for repairs, mention the Serial No. and Name of Machine indicated on the Sticker. The Serial Number indicates the product register. Identical machines could have different parts depending on the date of production. Also, improvements and modifications might have been made after the publication of this manual. In order to ensure you order the correct parts, mention the Serial No. when contacting the applicable places.

CONCERNING WARNING DISPLAYS

This SEGA product has warning displays on stickers, labels and/or printed instructions adhered/attached to or incorporated in the places where a potentially hazardous situation could arise. The warning displays are intended for accident prevention for customers and for avoiding hazardous situations relating to maintenance and servicing work. Some portions of the cabinet contain high voltage and may cause accidents if touched. When performing maintenance, be very careful of the warning displays. It is especially important that any complex repair and replacement work not mentioned herein should be performed by those technical personnel who have knowledge of electricity and technical expertise. In order to prevent accidents, caution any customer ignoring the warnings to cease and desist immediately.

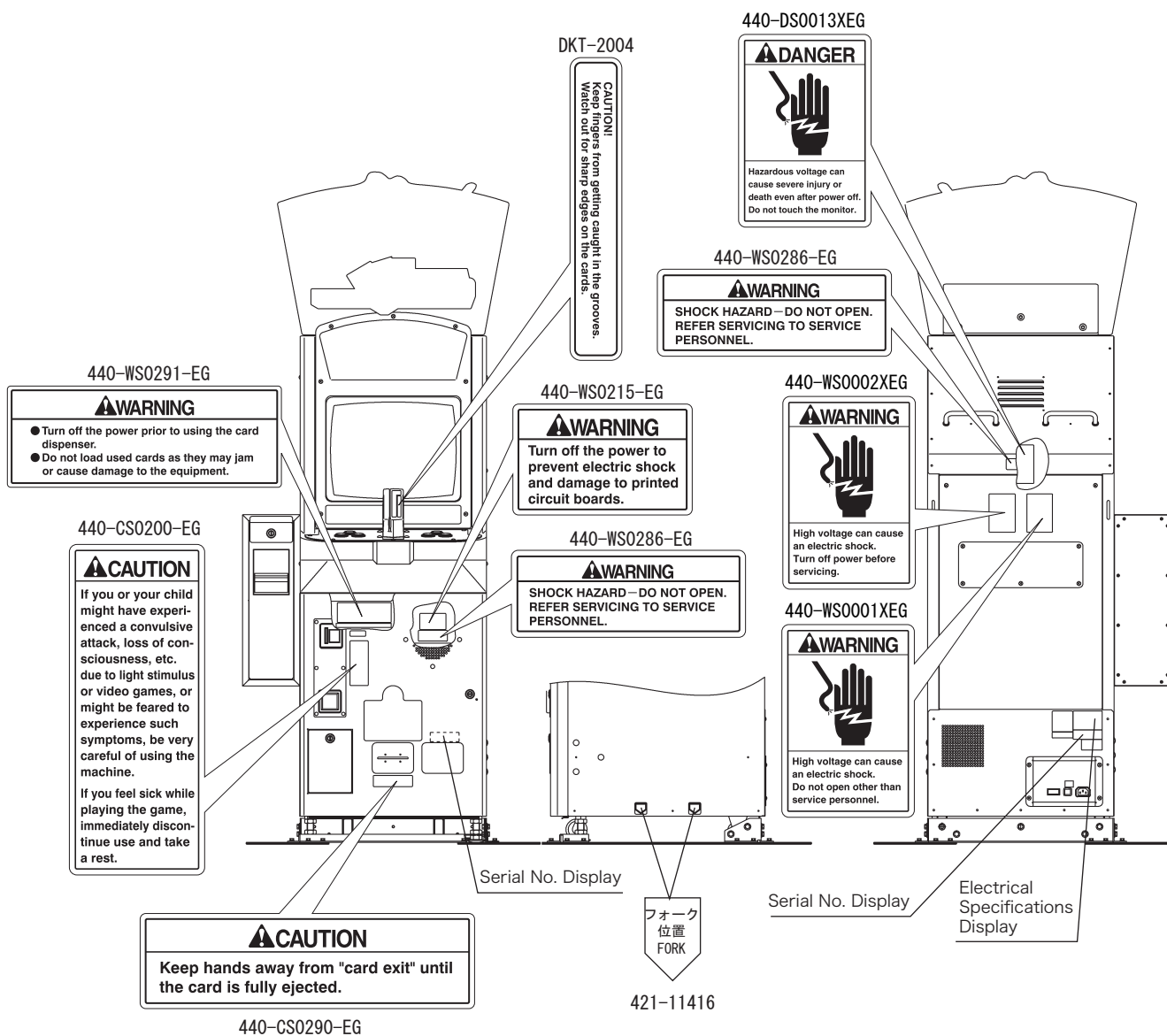

2. PRECAUTIONS REGARDING INSTALLATION LOCATION

2



WARNING

This product is an indoor game machine. Do not install it outside. Even indoors, avoid installing in places mentioned below so as not to cause a fire, electric shock, injury and/or malfunction.

- Places subject to rain or water leakage, or places subject to high humidity in the proximity of an indoor swimming pool and or shower, etc.
- Places subject to direct sunlight, or places subject to high temperatures in the proximity of heating units, etc.
- Places filled with inflammable gas or vicinity of highly inflammable/volatile chemicals or hazardous matter.
- Dusty places.
- Sloped surfaces.
- Places subject to any type of violent impact.
- Vicinity of anti-disaster facilities such as fire exits and fire extinguishers.
- The operating (ambient) temperature range is from 5°C to 30°C.

2-1 LIMITATIONS OF USAGE



WARNING

- Be sure to check the Electrical Specifications. Ensure that this product is compatible with the location's power supply, voltage and frequency requirements. A plate describing Electrical Specifications is attached to the product. Non-compliance with the Electrical Specifications can cause a fire and electric shock.
- This product requires a breaker and earth mechanism as part of the location facilities. Using the product without these can cause a fire and electric shock.
- Ensure that the indoor wiring for the power supply is rated at 7A or higher (AC single phase 100V~120V area), and 4A or higher (AC 220V~240V area). Non-compliance with the Electrical Specifications can cause a fire and electric shock.
- Be sure to use an independent power supply equipped with a surge-suppressor. Using a power supply without a surge-suppressor can cause an outbreak of fire if a power surge occurs.
- Putting many loads on one electrical outlet can cause generation of heat and a fire resulting from overload.
- When using an extension cord, ensure that the cord is rated at 7A or higher (AC 100V ~ 120V area) and 4A or higher (AC 220V~240V area). Using a cord rated lower than the specified rating can cause a fire and electric shock.

2



- For the operation of this machine, secure a minimum area of 0.75 m (W) x 1.2 m (D). In order to prevent injury resulting from falls/accidents during game play, be sure to secure the minimum area for operation.
- Be sure to provide sufficient space (150 mm minimum) so as to allow this product's ventilation fan to function efficiently. To avoid machine malfunctions or fires, do not place any obstacles near the ventilation opening.
- Do not allow objects to block the ventilation ports. It can cause generation of heat and a fire.
- SEGA shall not be held responsible for damage or compensation for damage to a third party, resulting from the failure to observe this instruction.

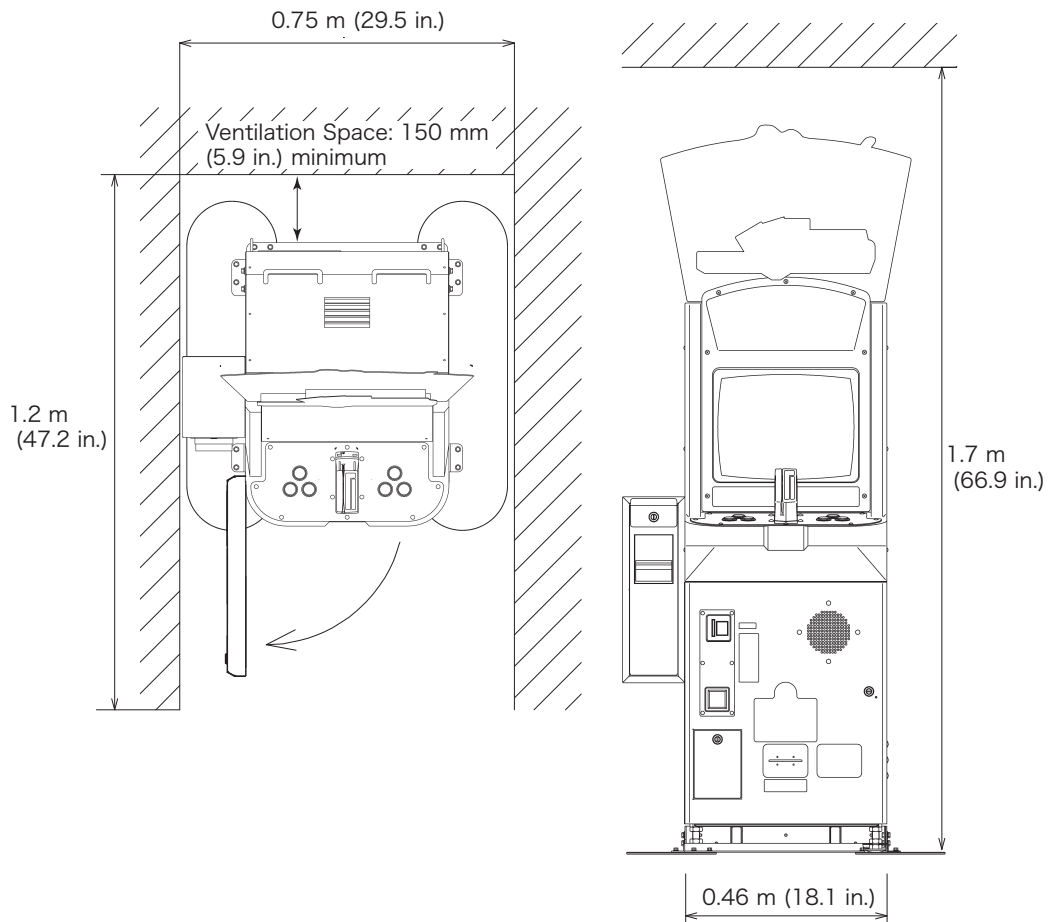

In order to transport the machine into a building, the minimum necessary dimensions of the opening (of doors, etc.) are 0.5 m (19.7 in.) [W] and 1.3 m (51.2 in.) [H].

Electricity Consumption:

MAX. 1.1 A (AC 120 V, 60 Hz)

3. PRECAUTIONS REGARDING PRODUCT OPERATION

To avoid injury and trouble, be sure to pay attention to the behavior of visitors and players.

3-1 BEFORE OPERATION



In order to avoid accidents, check the following before starting the operation:

- To ensure maximum safety for the players and the customers, ensure that where the product is operated has sufficient lighting to allow any warnings to be read. Operation under insufficient lighting can cause players to bump into each other, causing trouble between customers.
- Be sure to perform appropriate adjustment of the monitor (projector). Do not leave the machine operating with the monitor flickering or malfunctioning. Failure to observe this can have a negative effect upon the players' or the customers' physical condition.
- It is suggested to ensure a space for players who feel sick while playing the game to take a rest.
- Check if all of the adjusters are in contact with the surface. If they are not, the cabinet can move and cause an accident.
- Do not put any heavy items on this product. Placing heavy items on the product can cause accidents or damage to parts.
- Do not climb on the product. Climbing on the product can cause accidents. To check the top portion of the product, use a stepladder.
- To avoid electric shock, check that none of the door & cover parts are damaged or missing.
- To avoid electric shock, short circuit and or parts damage, do not put the following items on or in the periphery of the product. Flower vases, flowerpots, cups, water tanks, cosmetics, and receptacles/containers/vessels containing chemicals or water.

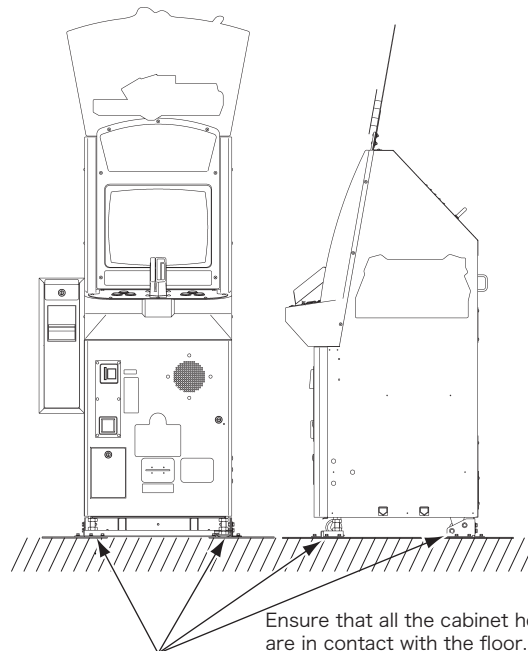

To avoid injury, be sure to provide sufficient space by considering the crowd situation at the installation location. Insufficient installation space can cause customers to bump into each other, causing trouble.

3-2 DURING OPERATION (PAYING ATTENTION TO CUSTOMERS)

To avoid injury and trouble, be sure to pay attention to the behavior of visitors and players.

3



- To avoid injury and accidents, those who fall under the following categories are not allowed to play the game.
 - Those who need assistance such as the use of an apparatus when walking.
 - Those who have high blood pressure or a heart problem.
 - Those who have experienced muscle convulsion or loss of consciousness when playing video games, etc.
 - Those who have neck or spinal cord problems.
- * Intoxicated persons.
- * Pregnant women or those who could be pregnant.
- * Persons susceptible to motion sickness.
- * Persons who disregard the product's warning displays.
- Even players who have never been adversely affected by light stimulus might experience dizziness or headache depending on their physical condition when playing the game. Small children are especially likely to experience these symptoms. Caution guardians of small children to keep watch on their children during play.
- It is suggested to provide a space for players who feel sick while playing the game to take a rest.
- Instruct those who feel sick during play to have a medical examination.
- To avoid injury from falls and electric shocks due to spilled drinks, instruct the player not to place heavy items or drinks on the product.
- To avoid electric shocks and short circuits, do not allow customers to put hands and fingers or extraneous matter in the openings of the product or small openings in or around the doors.
- To avoid falls and resulting injury, immediately stop the customer from leaning against or climbing on the product, etc.
- To avoid electric shocks and short circuits, do not allow customers to unplug the power plug without a justifiable reason.



Immediately stop such violent acts as hitting and kicking the product. Such violent acts can cause parts damage or cause the cabinet to fall over, resulting in injury.



Make sure to avoid disturbing customers when moving/removing the machine from its current location.

4. PART DESCRIPTIONS

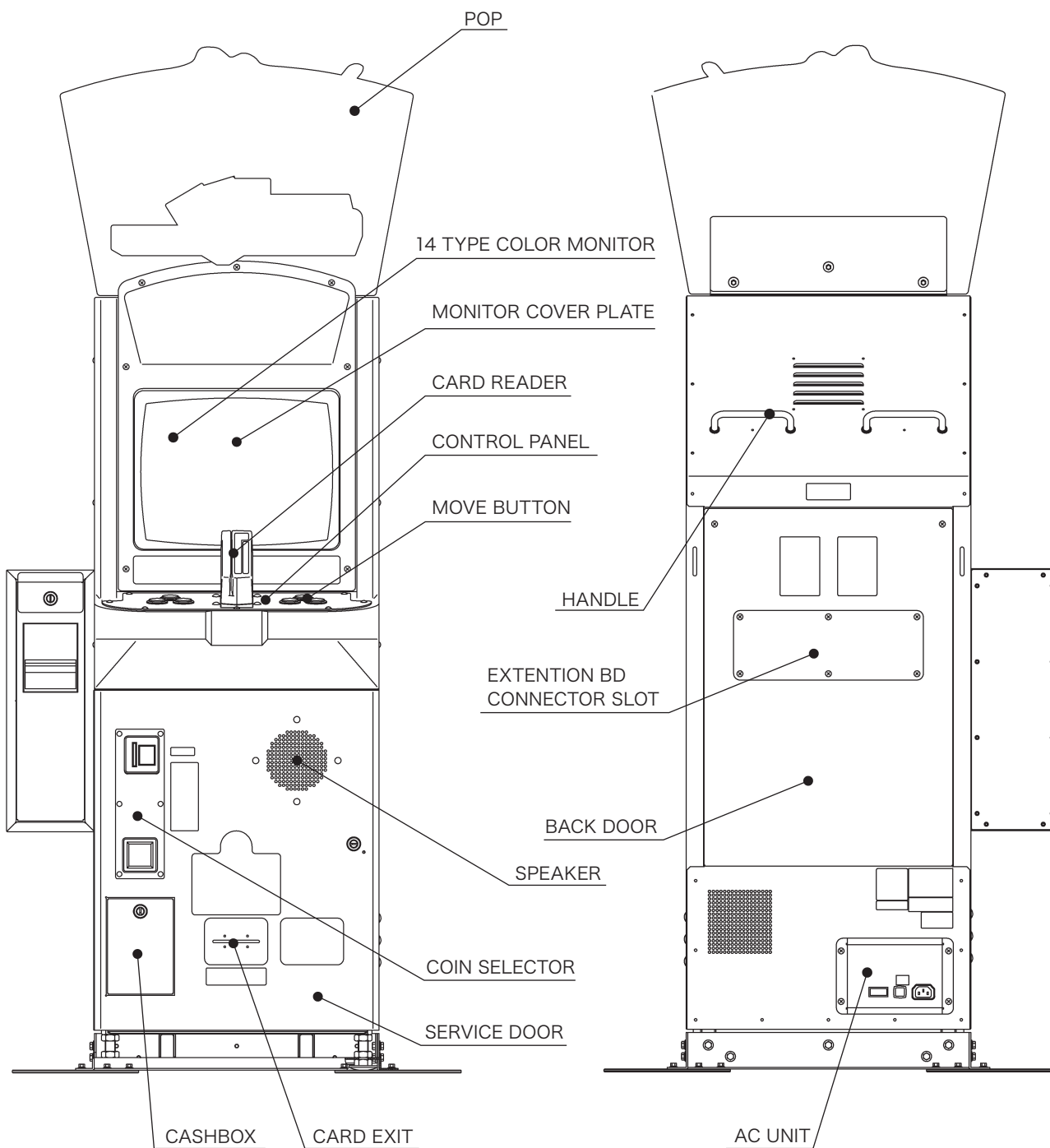
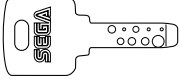
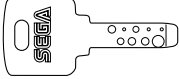

FIG. 4

5. ACCESSORIES

Confirm that the accessories listed in the table below are present when setting up the product. Accessories marked "Spare" in the note column are consumable items but included as spares.

TABLE 5a ACCESSORIES

DESCRIPTION :	OWNER'S MANUAL	KEY MASTER	KEY (2)
Part No. (Qty.) :	420-6805-02(1)	220-5785 (2)	For the cashbox door
Note :	This manual	For operating/ closing the door	The keys are inside the service door (near the cashbox side) at the time of shipment from the factory.
Figures :			
Parts not labeled with part numbers are as yet unregistered or cannot be registered. Be sure to handle all parts with care, as some parts are not available for purchase separately.			

The following Table 5b lists the parts that had been separately packed when the product was shipped from the factory but are necessary when you use the product. These parts will be mounted on the product when installing and assembling it.

TABLE 5b ACCESSORIES



<p>AC CABLE (POWER CORD) 600-7326 (1) Used for installation, See Section 6, [2].</p> 	<p>TRUSS SCREW (CHROME) 000-T00414-0C (3) Used for securing POP, See Section 6, [3].</p> 	<p>TAMPERPROOF WRENCH M4 540-0006-01 (1) or TAMPERPROOF DRIVER M4 540-0069 (1) Tool</p> 	<p>CLEANING CARD MKG-0011-01 (1)</p> 
<p>CABINET HOLD BASE (L, R) DKT-0009 (2) Used for installation, See Section 6, [1].</p> 	<p>CABINET HOLD BRKT RR UPPER DKT-0011 (1) Used for installation, See Section 6, [1].</p> 	<p>CABINET HOLD BRKT RR LOWER DKT-0012 (1) Used for installation, See Section 6, [1].</p> 	
<p>CABINET HOLD BRKT FR DKT-0010 (1) Used for installation, See Section 6, [1].</p> 	<p>HEXAGON BOLT M5x8 (BLACK) FAS-300048 (16) See Section 6, [1].</p>	<p>HEXAGON BOLT M6x16 (BLACK) 030-000616-SB (13) See Section 6, [1].</p>	<p>SPECIAL WASHER 068-652016-0B (13) See Section 6, [1].</p>

TABLE 5c 4DKG-0010-01 (POP DKG ENG)



6. ASSEMBLY AND INSTALLATION

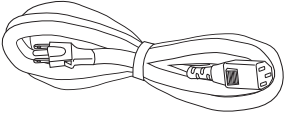

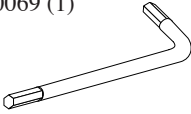
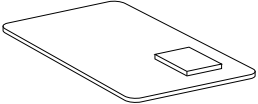
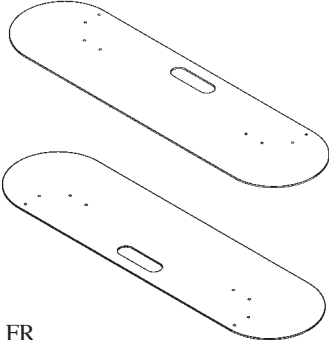
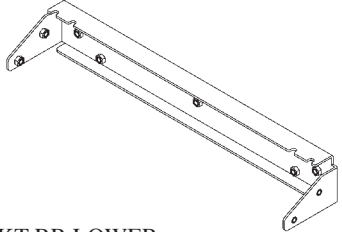
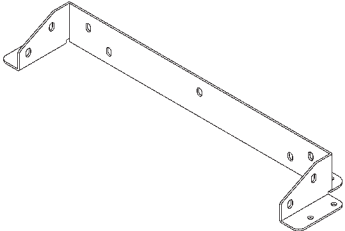
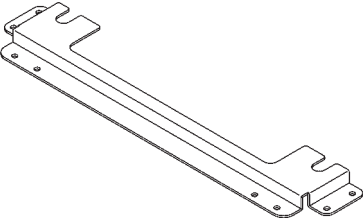
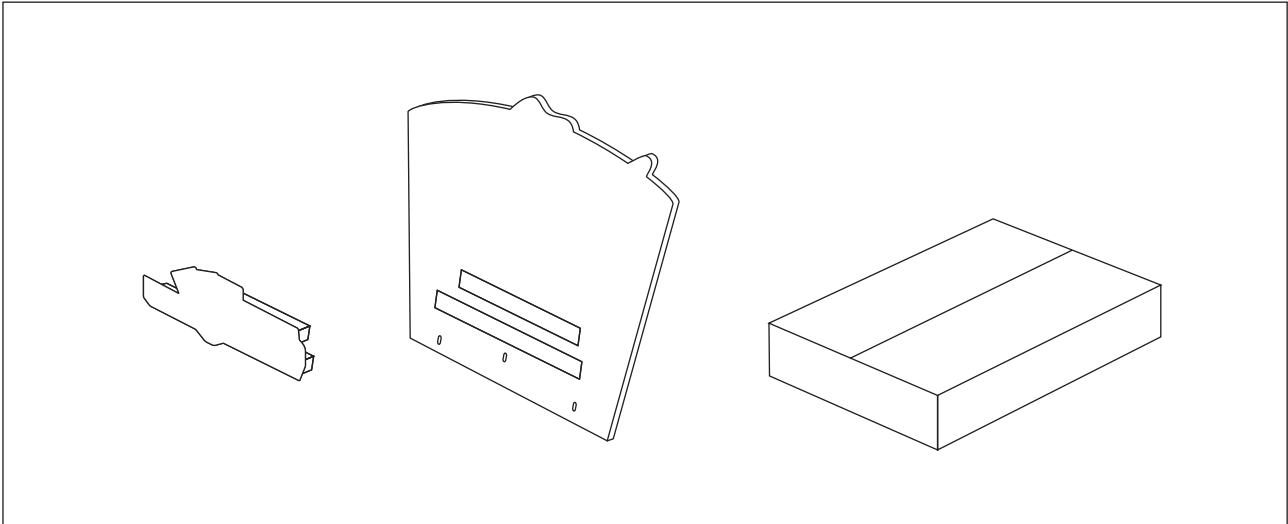
WARNING

6

- Perform assembly work by following the procedure herein stated. Failure to comply with the instructions can cause electric shock.
- Perform assembling as per this manual. Since this is a complex machine, incorrect assembling can cause an electric shock, machine damage and/or improper functioning as per specified performance.
- Ensure that connectors are accurately connected. Incomplete connections can cause electric shock.
- Be careful not to damage the wires. Damaged wires may cause electric shock or short circuit or present a risk of fire.
- This work should be performed by the site maintenance individual or other skilled professional. Performing work by non-technical personnel can cause a severe accident such as electric shock. Failing to comply with this instruction can cause a severe accident such as electric shock to the player during operation.
- Provide sufficient space so that assembling can be performed. Performing work in places with narrow space or low ceiling may cause an accident and assembly work to be difficult.
- To perform work safely and avoid serious accidents such as the cabinet falling down, do not perform work in places where step-like grade differences, a ditch, or slope exist.



CAUTION

Handle molded parts with care. Excessive weight or pressure may cause them to break and the broken pieces may cause injury.

When carrying out the assembling and installation, follow the following 6-item sequence.

- 1 SECURING IN PLACE (ADJUSTER ADJUSTMENT)
- 2 POWER SUPPLY AND EARTH CONNECTION
- 3 ASSEMBLING THE POP
- 4 INSERTING THE MANAGEMENT CHIP AND DINOSAUR KING CARDS (See Section 7)
- 5 POWERING ON
- 6 ASSEMBLY CHECK

Tools and Implements Required for the Work

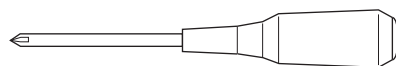

Phillips screwdriver (for M4 screws)

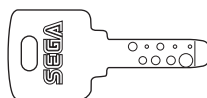

Master key

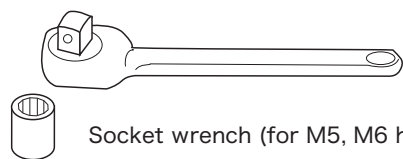

Socket wrench (for M5, M6 hexagon bolts)

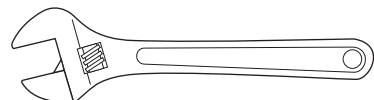

Spanner with a jaw width of 24 mm (for M16 hexagon bolts)

1 SECURING IN PLACE (Attaching Cabinet Hold Brackets)



- Make sure that all the adjusters are resting on the floor. The cabinet may move and cause an accident if the adjusters are not laid out properly.
- When aligning the adjusters, be sure to also secure the cabinet hold brackets to prevent tipping. Failure to do so could result in injury or other hazards.
- The cabinet hold brackets have been added to the game with the purpose of widening the games footprint and add stability. UL 22 requires that the cabinet hold brackets are properly installed prior to the games operation. SEGA cannot be responsible for any actions resulting in failure to follow these instructions.



The adjusters are made of metal and therefore present a risk of damaging the floor. Be sure to keep this in mind when positioning the cabinet.

The cabinet is equipped with 4 casters and 2 adjusters. After deciding on a location, bring the adjusters into direct contact with the ground and adjust the cabinet so that it is completely level.

- ① Move the cabinet to the desired location. Make sure there is space in the back for air to flow.
- ② Spread bubble wrap or another suitable material so as not to damage the cabinet and then lower it gently onto the ground so that the bill acceptor is facing upwards.

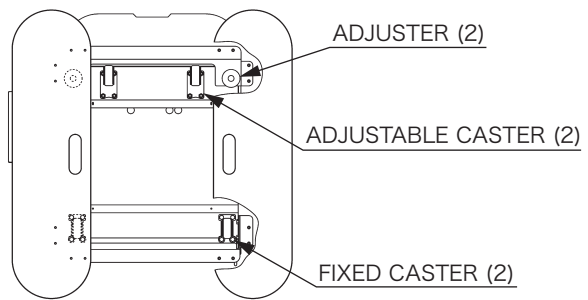

FIG. 6.1 a Bottom View

- ③ Remove the 2 hexagon bolts from the outside of each fixed caster.

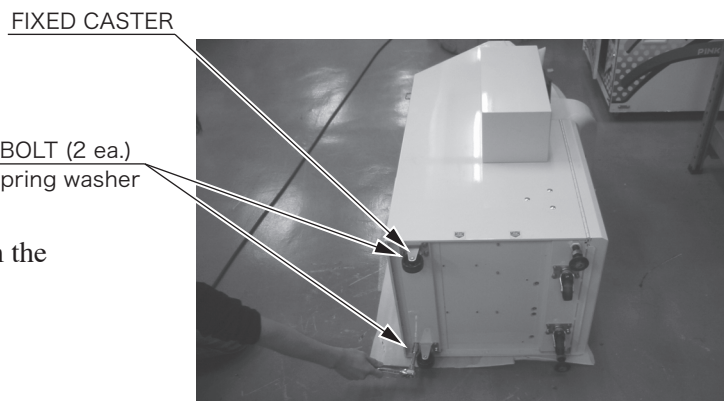

PHOTO 6.1a

- ④ Use the hexagon bolts and special washers provided to temporarily hold the casters in place.

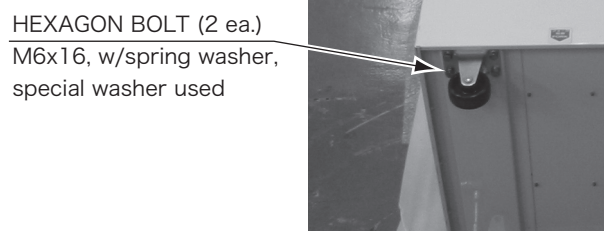

PHOTO 6.1b

- ⑤ Attach the supplied CABINET HOLD BRKT RR UPPER using the temporarily holding hexagon bolts on the front side.

CABINET HOLD BRKT RR UPPER

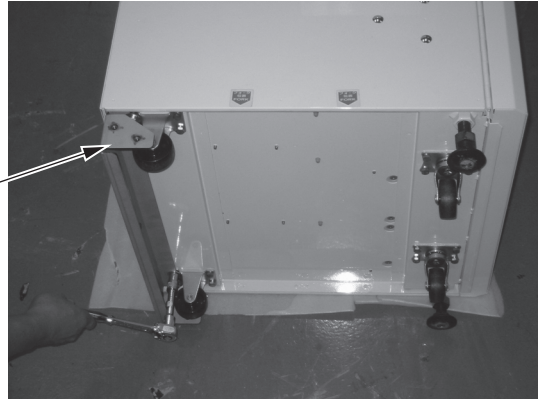

PHOTO 6.1c



PHOTO 6.1d

- ⑥ Raise the cabinet and return it to an upright position, placing it on top of CABINET HOLD BASE L and R. Use the leg adjusters to make sure that the cabinet is perfectly level at this point.

CABINET HOLD BRKT R

CABINET HOLD BRKT L

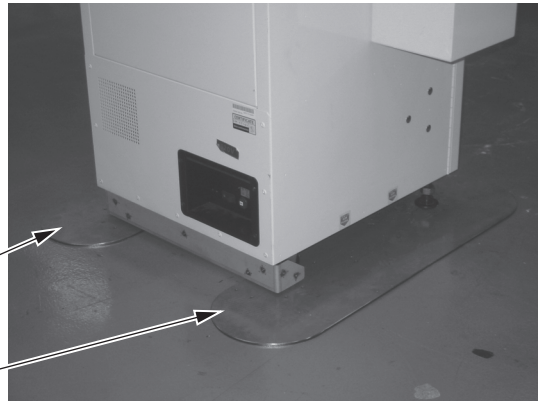

PHOTO 6.1e

- ⑦ Insert the CABINET HOLD BRKT FR between the leg adjusters and the hexagon nut, and then tighten the nut downwards to fix it in place.

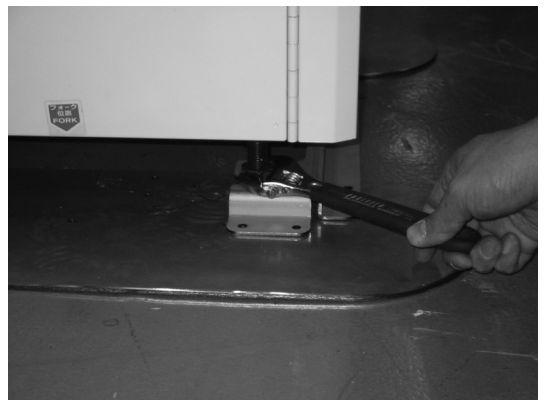
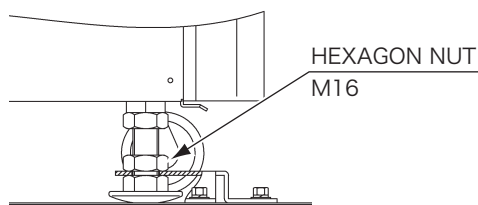

PHOTO 6.1f

- ⑧ Next attach the CABINET HOLD BRKT RR LOWER to the already attached frontal CABINET HOLD BRKT RR UPPER using the supplied hexagon bolts.

HEXAGON BOLT/M6x16,
w/spring washer,
special washer used

CABINET HOLD BRKT RR LOWER

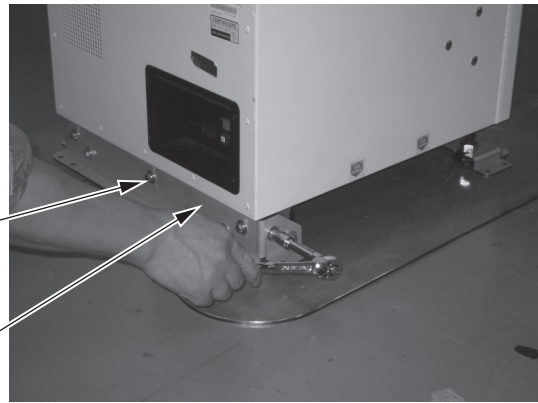

PHOTO 6.1g

- ⑨ Use the supplied hexagon bolts to firmly attach CABINET HOLD BRKT FR and CABINET HOLD BRKT RR LOWER to CABINET HOLD BASE L/R.

HEXAGON BOLT/M5x8,
w/flat & spring washers

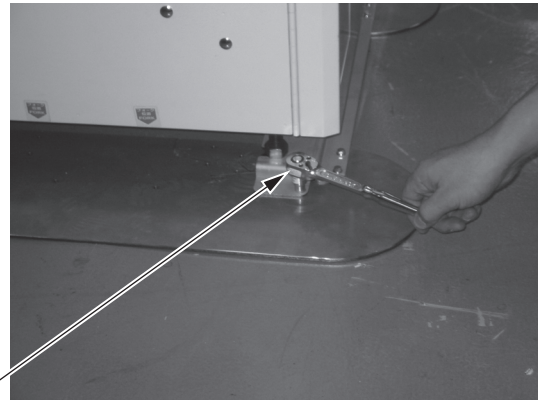

PHOTO 6.1h

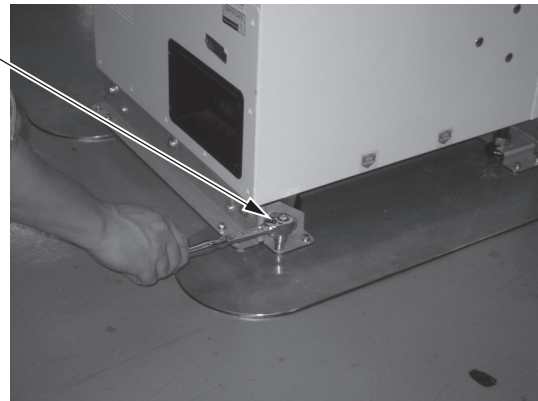

PHOTO 6.1i

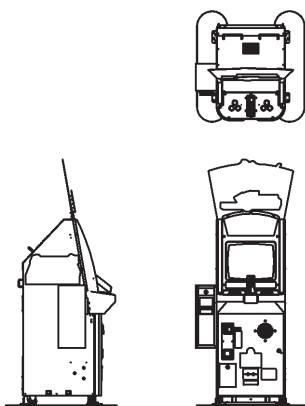

FIG. 6.1b

(Scale: 1/50) See the layout for the positioning location.

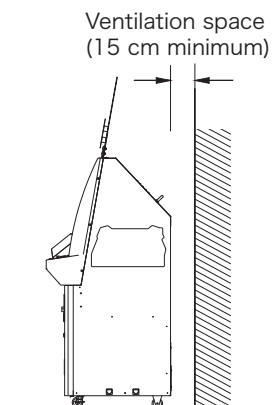

FIG. 6.1c Ensuring Ventilation Space

2 POWER SUPPLY AND EARTH CONNECTION



6

- Be sure to independently use the power supply socket outlet equipped with an Surge Suppressor. Using a power supply without a Surge Suppressor can cause a fire when electric leakage occurs.
- Ensure that the "accurately grounded indoor earth terminal" and the earth wire cable are available (except in the case where a power cord plug with earth is used). This product is equipped with an earth terminal. Connect the earth terminal and the indoor earth terminal with the designated cable. If the grounding work is not performed appropriately, customers can be subjected to an electric shock, and the product may not function properly.
- Ensure that the power cord and earth wire are not exposed on the surface (passage, etc.). If exposed, they can be caught and are susceptible to damage. If damaged, the cord and wire can cause electric shock and short circuit accidents. Ensure that the wire is not in the customer's way and that the wiring has protective insulation.
- After wiring the power cord on the floor, be sure to protect the power cord. An exposed power cord is susceptible to damage and may cause an electric shock.

The AC unit is located at the back of the cabinet.

The AC unit features a main switch, a circuit protector, and an inlet for connecting the power cord.

- ① Ensure that the main switch is OFF.

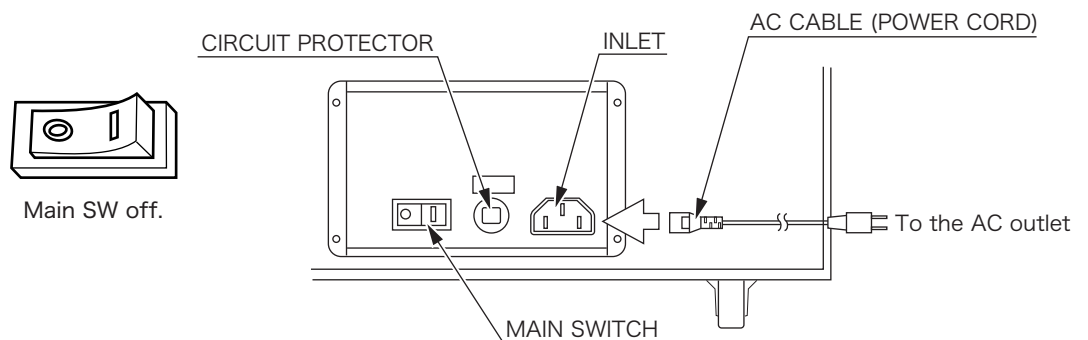

FIG. 6.2a

- ② Firmly insert the power plug into the socket outlet. Insert the opposite side of the power cord plug to the AC Unit's connector ("INLET").
- ③ Perform wiring for the power cord. Install protective insulation for the power cord.

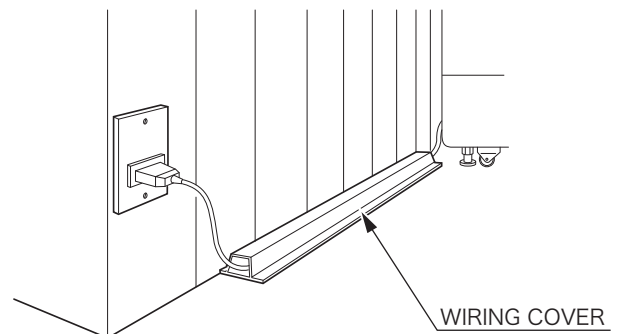

FIG. 6.2b Connecting the Power Cord

3 ASSEMBLING THE POP

- ① Remove the separation paper of the double-sided tape on the POP B back side, and attach to the POP A firmly.

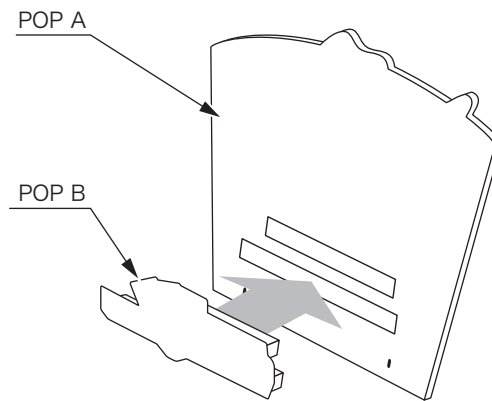

FIG. 6.3a

- ② Remove the 3 truss screws (M4 × 12) from the cabinet, replacing them with the 3 supplied truss screws (M4 × 14), and fasten the POP as shown in the figure on the right.
The POP support board for this machine is packed in air-wrap and secured to the front of the monitor cover.

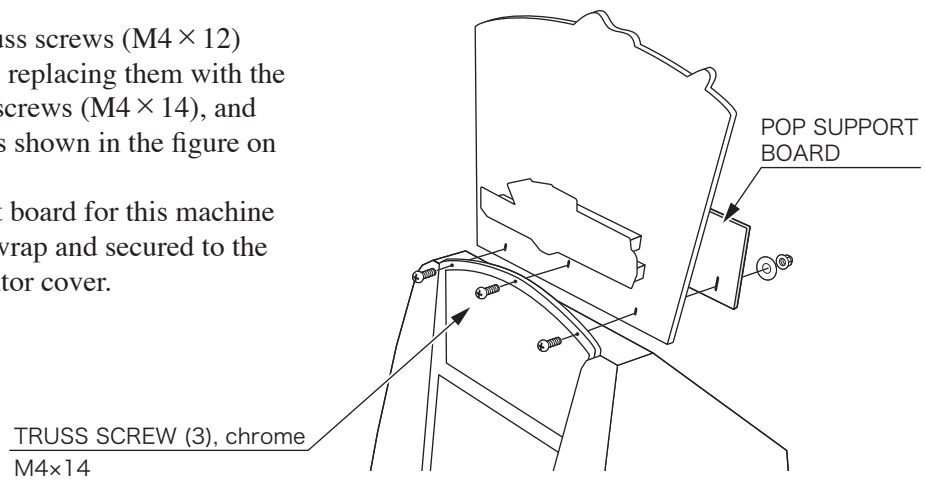

FIG. 6.3b

4 INSERTING THE MANAGEMENT CHIP AND DINOSAUR KING CARDS

While consulting section 7, “MANAGEMENT CHIP AND DINOSAUR KING CARDS”, insert the Management Chip into the Management Chip reader/writer, and load the cards into the card dispenser.

MANAGEMENT CHIP
MANAGEMENT CHIP READER/WRITER

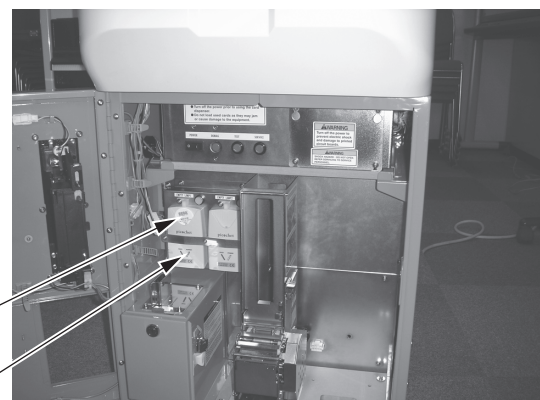

PHOTO. 6.4

5 POWERING ON



IMPORTANT

This machine cannot be powered on unless both the AC unit on the back of the cabinet and the power switch in the maintenance switch section on the inside of the service door are both turned on.

Turning on the AC unit main switch and the maintenance switch will power on the machine. When powering on the machine, the system start-up screen will be displayed, and an advertisement screen will be shown afterwards. On this machine, the number of credits will be saved even after shutting off the power. If credits allowing further play remain in the machine when powered off, a card will be dispensed and a game will begin when the machine is restarted.

6

- In the event that there are no cards loaded into the card dispenser, a “CARD ERROR” message screen will be displayed. In such a case, turn off the machine, load cards, and turn it on again.
- To adjust the sound volume, press the TEST Button and enter the SOUND TEST in the Test Mode. Also, the choice of whether or not to play sound during the advertisement screen can be selected in the TEST MODE settings.

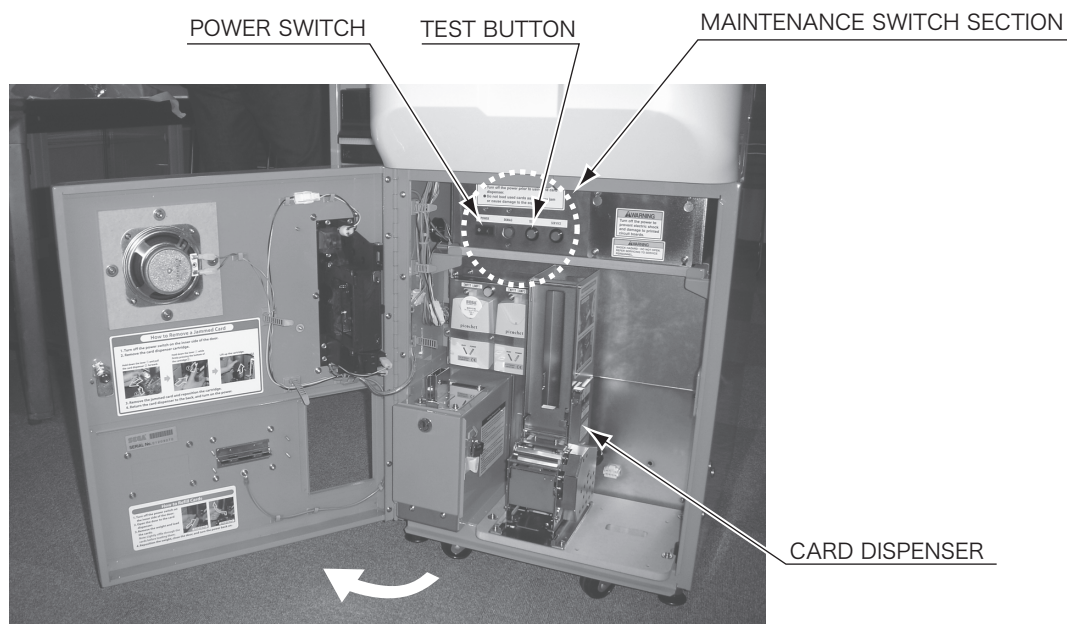

PHOTO. 6.5

6 ASSEMBLY CHECK

After powering on, press the SERVICE Button in the maintenance switch section to make sure that the machine is working properly.

Confirm the following items during operation:

- Are the cards dispensed properly?
- Does the game proceed properly on the screen?
- Do the input buttons work properly?
- Is the card scan carried out properly?

For more detailed, specific confirmation, refer to the TEST MODE. (See Section 11.)

7. MANAGEMENT CHIP AND DINOSAUR KING CARDS



WARNING

- Turn off the power prior to using the card dispenser.
- Do not load used cards as they may jam or cause damage to the equipment.



IMPORTANT

- Do not perform any of the following actions to avoid damaging the machine.
- Removing the Management Chip or turning the power on/off when the red Management Chip reader/writer "BUSY" lamp is flashing.
 - Removing/inserting Management Chips while a game is in progress.
 - Inserting Management Chips/Cards designed for other machines or game versions.
 - Loading more than the maximum number of cards (600). Doing so can result in card jamming or faulty dispensing.

7

7-1 INSTALLING MANAGEMENT CHIP

The Management Chip is supplied with the card set for use with this machine.

- ① Turn off the power switch inside the door.
- ② Loosen the screw locking the Management Chip holder.
- ③ Insert the Management Chip firmly into the Management Chip reader/writer slot.
- ④ Turn on the power switch inside the door.
- ⑤ If the "EMPTY LAMP" lights up, there may be a malfunction. Check that the chip is correctly inserted.

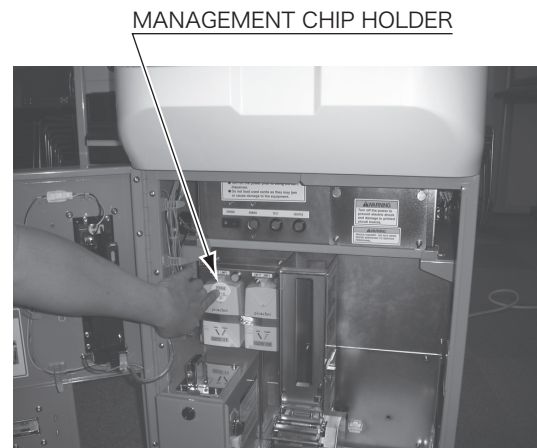

PHOTO 7.1

Notes :

- Be sure to turn the power off and on again when inserting/removing Management Chips, even if the machine is in use.
- The counter in the Management Chip is set for the number of cards in one carton, and each dispensed card reduces the counter number by 1. One Management Chip allows game operation for one carton of cards.

When the credits reach zero and the warning screen is displayed, install a new Management Chip. A Management Chip that causes the "EMPTY LAMP" to light up cannot be used.

There are two reader/writer units. If the chip is recognized by either one of them, the game can be operated.

The status of the chip can be verified in Test Mode.

MANAGEMENT CHIP INDICATORS

- **POWER LAMP:** The green lamp lights up when the machine has properly recognized the reader/writer units.
- **BUSY LAMP:** The red lamp flashes when the reader/writer is communicating with the Management Chip. Do not remove the Management Chip when the lamp is blinking. In addition, do not turn the power off or perform any other operations on the machine.
- **EMPTY LAMP:** This lamp lights up when either the credits for the Management Chip reach zero or when an error has occurred with the Management Chip reader/writer.

7

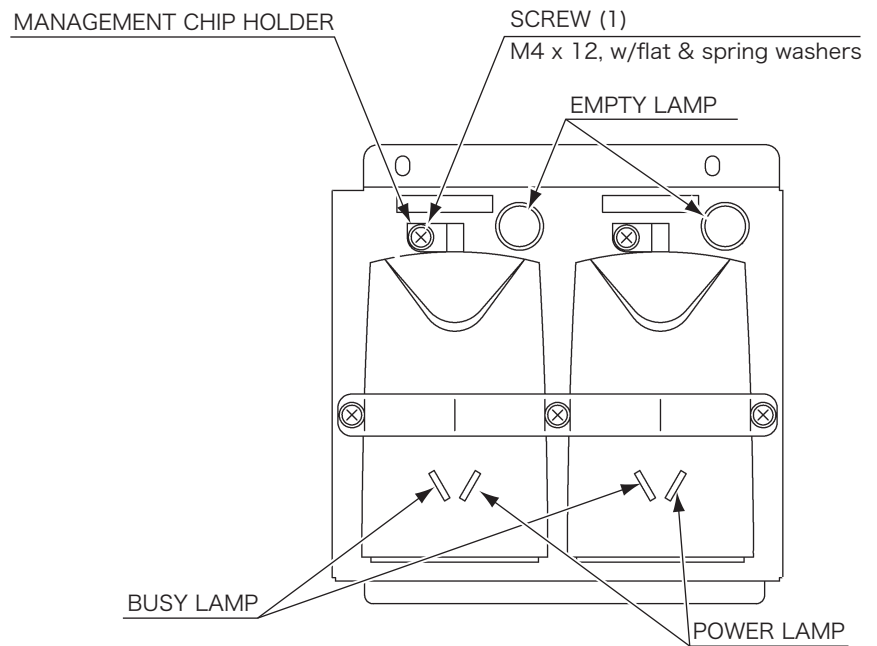

FIG. 7.1

7-2 MANAGEMENT CHIP ERROR CODES

When problems occur with the Management Chip, the following error codes will be displayed on the screen. Refer to the “cause” and “countermeasures” list below in order to deal with the problem appropriately.

The following error codes will not be displayed if either the Management Chip or the reader/writer is functioning properly.

ERROR 100: Management Chip, reader/writer error

- [DISPLAY] ERROR 100
RFID READER NOT READY
(If the error occurs in Test Mode, “READER NOT READY” is displayed)
- [CAUSE] The wire connection is not properly configured, or there may be a broken wire or damaged hardware.
- [COUNTERMEASURES] Turn off the power, check the wire connection, and then restart the machine. If the problem still persists, the machine may be damaged. Replace broken parts with new ones.

ERROR 101: Management Chip read error

- [DISPLAY] ERROR 101
RFID READ ERROR
(If the error occurs in Test Mode, “READ ERROR” is displayed)
- [CAUSE] (1) The wire connection is not configured properly, or there may be a broken wire or damaged hardware.
(2) The Management Chip is not inserted properly in the slot.
- [COUNTERMEASURES] (1) Turn off the power, check the wire connection, and then restart the machine. If the problem still persists, the machine may be damaged. Replace broken parts with new ones.
(2) Check the status of the Management Chip and reinsert it. The chip may be damaged. Replace it with a new one if necessary.

ERROR 102: Management Chip write error

- [DISPLAY] ERROR 102
RFID WRITE ERROR
- [CAUSE] The process of writing data to the Management Chip does not complete properly. The verified data does not match the results of the data check. The Management Chip is not inserted properly in the slot.
- [COUNTERMEASURES] Reinsert the Management Chip properly. If the problem still persists, the chip may be damaged. Replace it with a new one.

ERROR 103: Management Chip decrement error

- [DISPLAY] ERROR 103
RFID DECREMENT ERROR
- [CAUSE] The process of credit reduction does not complete properly. The counter does not decrease by 1 after the reduction process. The Management Chip is not inserted properly in the slot.
- [COUNTERMEASURES] Reinsert the Management Chip properly. If the problem still persists, the chip may be damaged. Replace it with a new one.

ERROR 104: Management Chip data error 1

- [DISPLAY] ERROR 104
RFID UNKNOWN ERROR
(If the error occurs in Test Mode, “UNKNOWN CHIP FORMAT” is displayed)
- [CAUSE] The inserted Management Chip is not for the correct machine or game version.
- [COUNTERMEASURES] Verify again that the Management Chip is correct.

ERROR 105: Management Chip data error 2

- [DISPLAY] ERROR 105
AN ILLEGAL USE ERROR
(If the error occurs in Test Mode, “THIS CHIP IS INVALID” is displayed)
- [CAUSE] The inserted Management Chip has been used previously and is illegal because its remaining credits have increased.
- [COUNTERMEASURES] Verify again that the Management Chip is correct.

7

WARNING DISPLAY FOR MANAGEMENT CHIP EXPIRATION

- [DISPLAY] Refer to the screen display on the right.
(If the error occurs in Test Mode, “0” is displayed without an error message.)
- [CAUSE] The remaining credits on the Management Chip counter is “0”.
- [COUNTERMEASURES] When this screen appears, quickly replace the chip with a new one, or a chip that still has remaining credits.



Note : This screen only appears when all the chips installed in the reader/writer units have no remaining credits left.

7-3 REFILLING CARDS

When the card stock runs out while the game is operating, a warning screen will be displayed.

If this screen is displayed, be sure to promptly refill the cards.



PHOTO 7.3a Warning Screen when Out of Cards

HOW TO REFILL CARDS

- ① Open the service door and turn off the power switch in the maintenance switch section.

POWER SWITCH

CARD DISPENSER

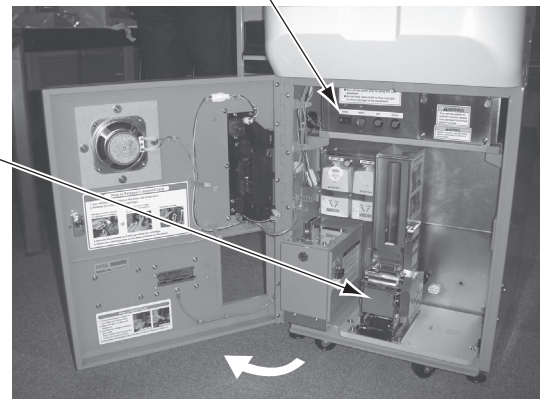

PHOTO 7.3b

- ② While pushing the lever, raise it to open up the dispenser.

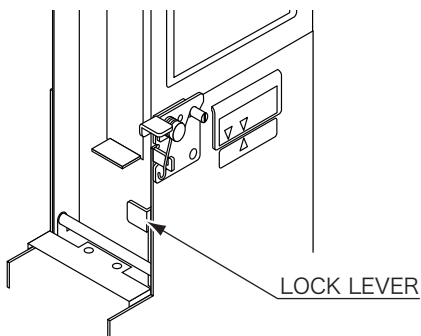

FIG. 7.3a

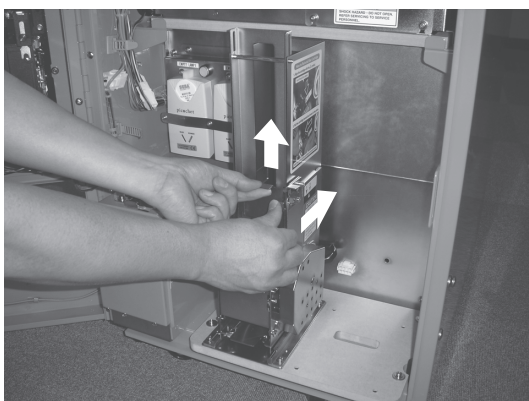

PHOTO 7.3c

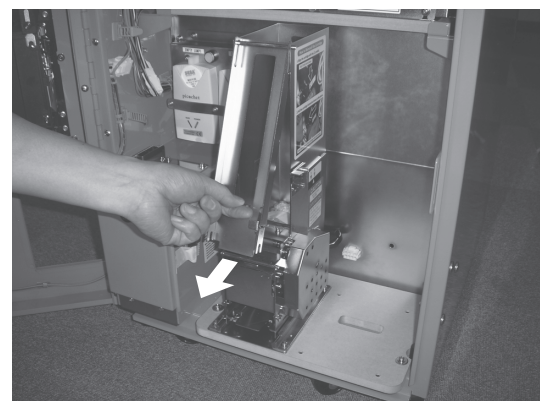

PHOTO 7.3d

- ③ Take out the card weight. This part is covered in an air-wrap bag at the time of shipping.

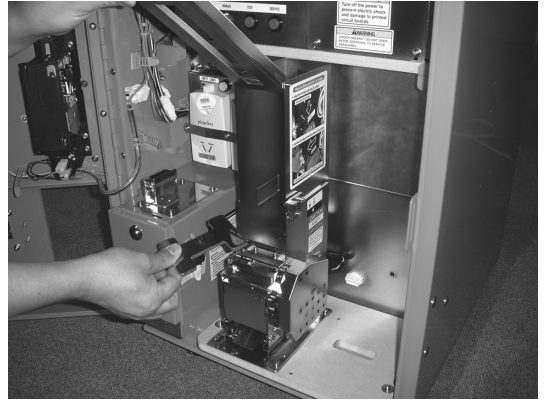

PHOTO 7.3e

7

- ④ Take the wrapping off the new cards and gently riffle through them.
- Load the cards with the front faced down.
 - Cards come in packs of 200.



PHOTO 7.3f

- ⑤ Refill the cards. Do not load more than 600 cards.
- ⑥ Reposition the weight and close the refill door.
- ⑦ Turn the power back on and close the service door.



PHOTO 7.3g

7-4 DEALING WITH JAMMED CARDS

If a card jam occurs while the game is operating, a warning screen will be displayed. If this screen is displayed, be sure to remove the jammed card immediately.



PHOTO 7.4a
Jammed Card Warning Screen

7

HOW TO REMOVE A JAMMED CARD

- ① Open the service door and turn off the power switch in the maintenance switch section .
- ② Hold down the lock lever on the bottom section of the card dispenser and pull out the card dispenser.

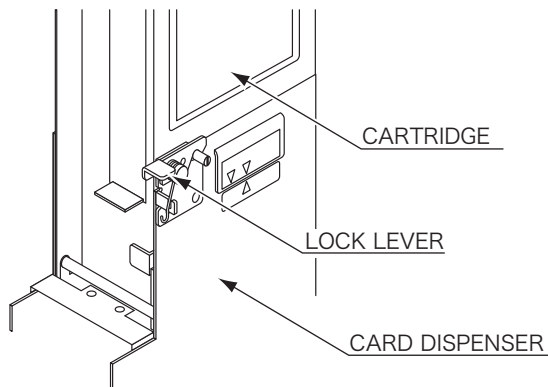

FIG. 7.4a

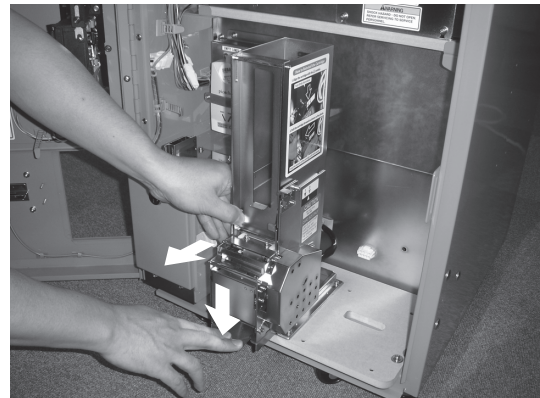

PHOTO 7.4b

- ③ Push firmly on the front bottom of the cartridge while holding down the lock lever on the right. The cartridge will slide back and stop.

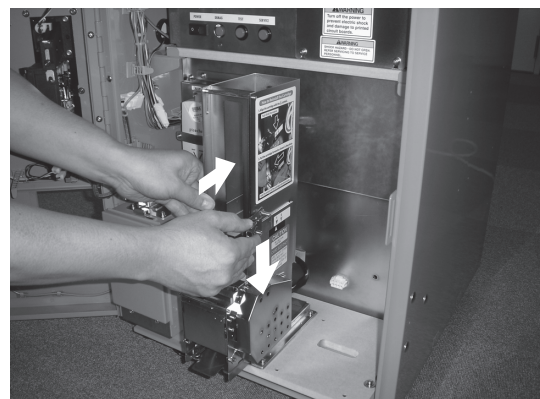

PHOTO 7.4c

- ④ Lift up and release the cartridge. In some cases the bottom-most card will be stuck but proceed to lift up the cartridge. Afterwards, remove the jammed card.



PHOTO 7.4d

- ⑤ Reposition the cartridge. Align the cartridge with the “△” symbol by pushing firmly from above. Then pull the cartridge forward with both hands as shown in the picture.

Reinstalling the cartridge improperly will result in card dispenser malfunctions. Be sure to consult the diagram below and proceed carefully.

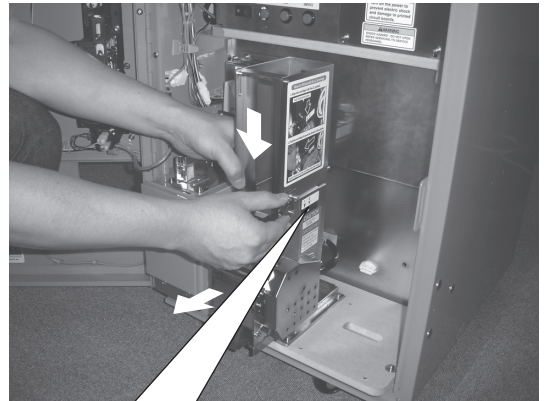
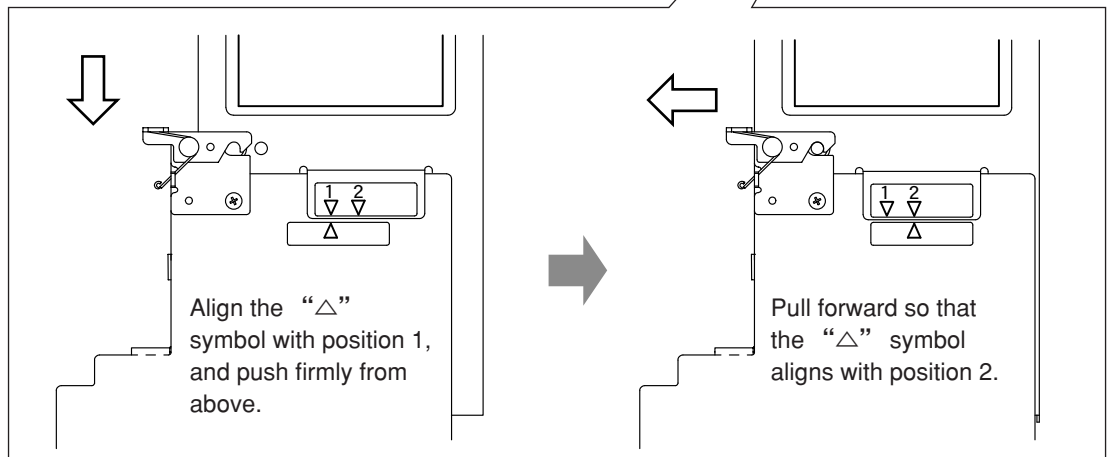

PHOTO 7.4e



- ⑥ Return the card dispenser to the back.
- ⑦ Turn the power back on and close the service door.

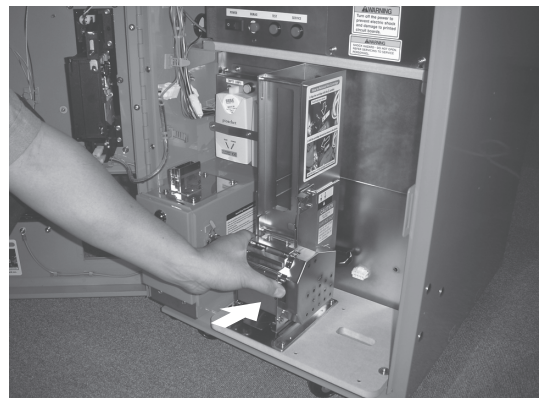

PHOTO 7.4f

CARTRIDGE REINSTALLATION WARNING

As shown in the diagram, be sure that the cartridge is not slanted off center and that the cartridge tabs are locked securely into the card dispenser.

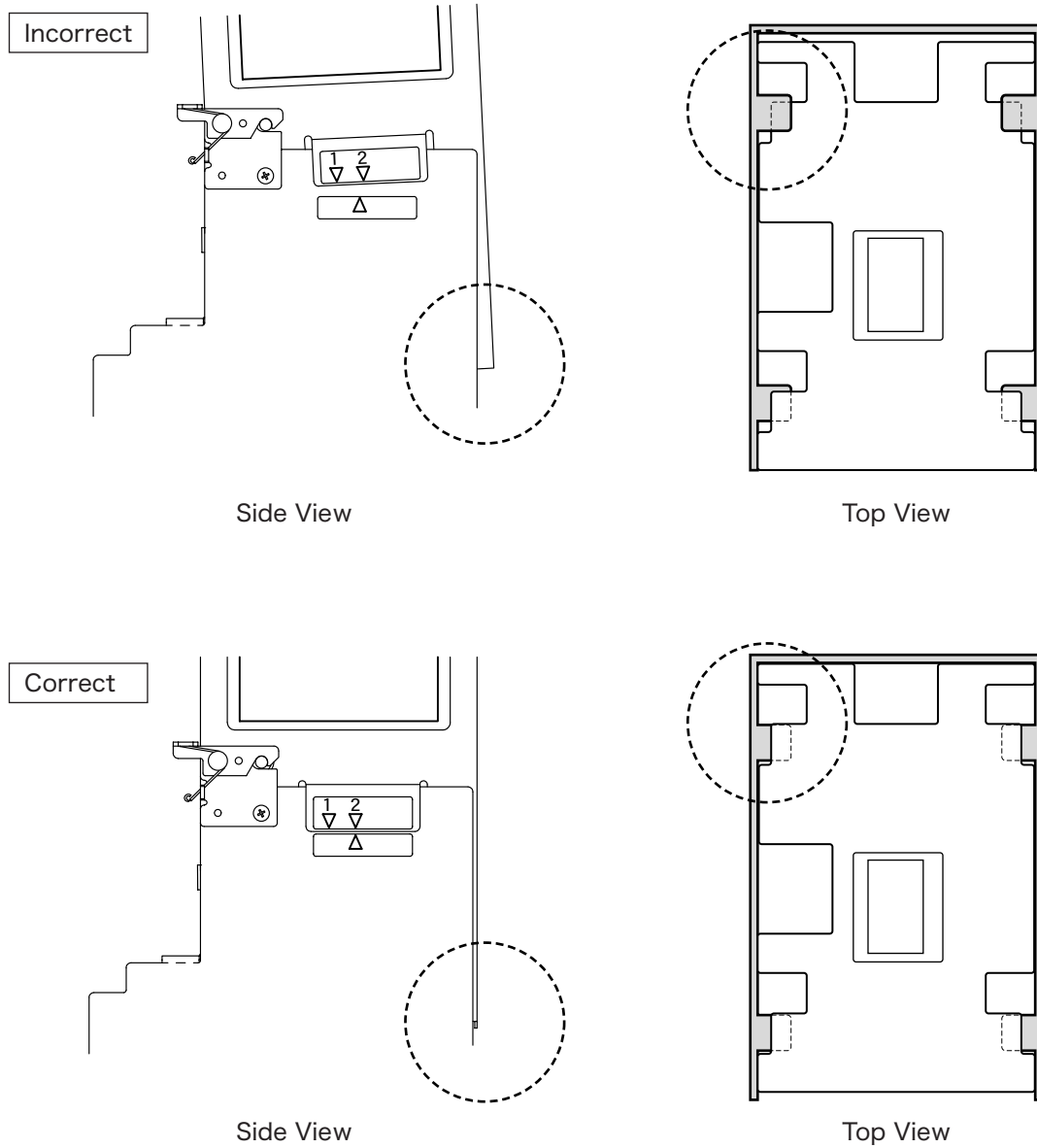

FIG. 7.4b

8. PRECAUTIONS WHEN MOVING THE MACHINE



- When moving the machine, be sure to pull out the plug from the power supply. Moving the machine with the plug still inserted can cause the power cord to be damaged, resulting in a fire and/or electric shock.
- When moving the machine on the floor, remove the hold brackets and retract the adjusters, and ensure that the casters make contact with the floor. Pay careful attention so that the casters do not run over power cords and earth wires. Damaging the power cords can cause an electric shock and/or short circuit.
- When the casters are in contact with the floor, it is possible that the cabinet can move under its own weight if placed on an uneven area so extra care must be taken.
- When lifting the cabinet, be sure to hold the handles and the bottom part. Lifting the cabinet by holding other portions may damage parts and installation portions due to the empty weight of the cabinet, and may cause personal injury.

8



Do not push the front mask or molded parts. This may cause damage to the components, and the pieces may in turn cause injury.

Do not apply pressure to the cabinet's molded parts when moving the cabinet. There is a risk of breaking components and/or causing personal injury. When moving, be sure to use the handles at the upper back end of the cabinet.

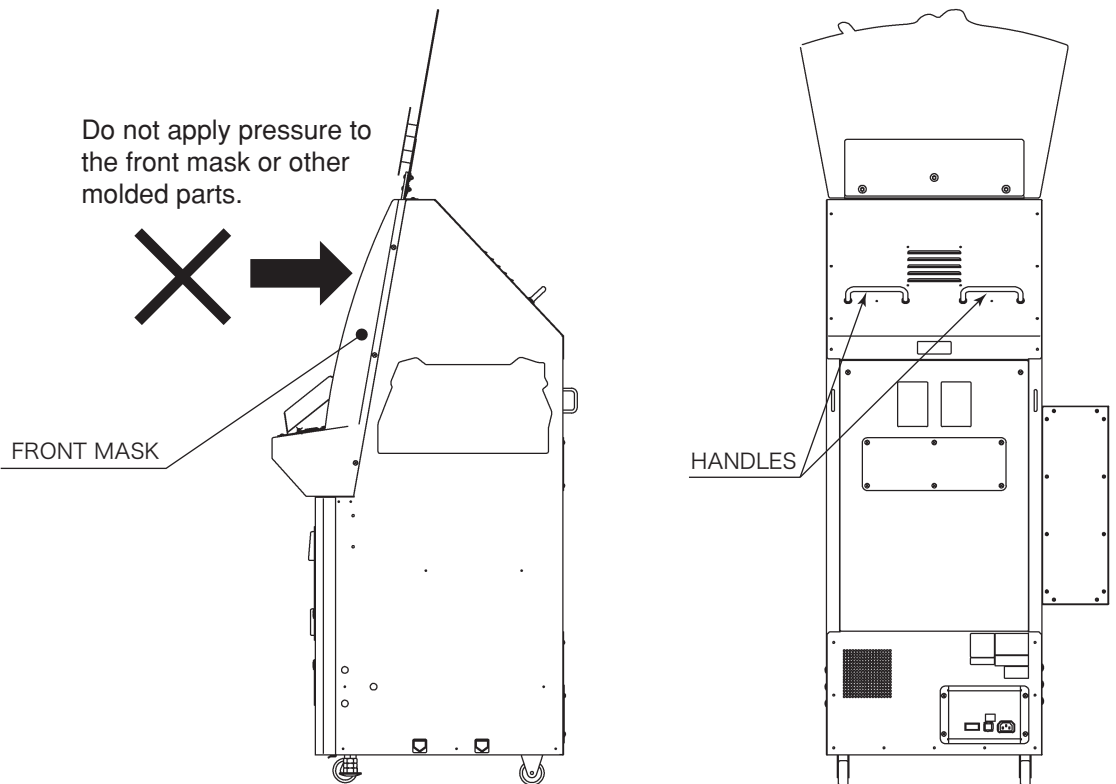

FIG. 8

9. GAME DESCRIPTION

The following explanations apply only if the product is functioning correctly. If anything differs from below, then a problem may have occurred. Immediately look into the cause of the problem and fix it to ensure proper operation.

In order to draw maximum attention during standby mode the monitor constantly displays the Attract Mode (waiting-for-player) screen.

This screen, which includes the Dinosaur King story and game instructions (with sound and BGM), loops repeatedly until coins are inserted. The option of whether or not to play sound during the Attract Mode screen can be configured in Test Mode settings.

GAME OUTLINE

- A Dinosaur King Card is dispensed at the beginning of play. The player then scans one of their Dinosaur Cards (using the Card Reader) to make that dinosaur appear in the game.
- Dinosaur King Cards are comprised of three types; Dinosaur Cards, Move Cards and Super Move Cards. One Dinosaur Card and up to three Move Cards and Super Move Cards can be scanned per play. Furthermore, the strength of the dinosaur will vary depending on the combination of the cards.
- Both available game modes, One Player Mode and Two-Player Mode, involve battling against another dinosaur, where the first dinosaur to eliminate all of the opponent's health is the winner.
- During the countdown to battle, a rock-scissors-paper game determines who will attack.
- The "Rock," "Scissors," and "Paper," attacks have varying attack power among the different dinosaurs, thus giving an element of strategic planning to the rock-scissors-paper game.

HOW TO PLAY: Game Controls

- ① Insert coins.
- ② A Dinosaur King Card is dispensed. *
- ③ The game starts on-screen.
- ④ Scan Dinosaur King Cards.
- ⑤ Use the Move Buttons to play rock-scissors-paper.

* Dinosaur King Cards are dispensed randomly. The player cannot choose between Dinosaur Cards, Move Cards and Super Move Cards.

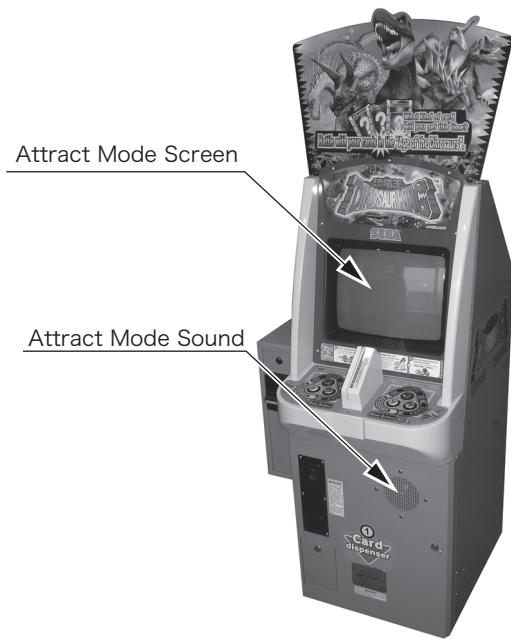

PHOTO 9a



PHOTO 9b

HOW TO PLAY: Screen Flow

- ① After inserting coins, a card will be dispensed.
- ② Taking the Card will begin the game.
Use the Move Buttons to select One-Player Mode or to go head-to-head against another player in Two-Player Mode. (Screen 1)

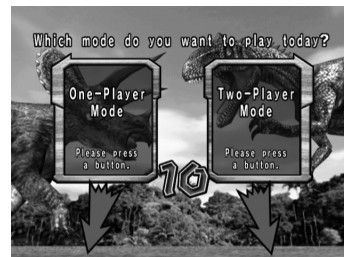

Screen 1

- ③ If One-Player Mode is selected, a prompt will appear on the screen asking for Cards to be scanned. Scan any Dinosaur Card that you like. (Screen 2)

NOTE: Even if no Dinosaur Card is scanned, a substitute dinosaur will appear in battle and the game will proceed.



Screen 2

- ④ A prompt will then appear asking for Move Cards to be scanned. Scan Move Cards or Super Move Cards. (Screen 3)

NOTES :

- A Super Move Card can be scanned instead of a Move Card. The game will proceed even if Move Cards are not scanned.
- There are six types of Super Move Cards; Fire, Water, Lightning, Earth, Grass and Wind.
- Only a Move Card of the same type as that written on the scanned Dinosaur Card can be used. (See "Using Dinosaur King Cards.")



Screen 3

- ⑤ After completing all card scanning, the degree to which the dinosaur has been powered-up (enhanced attack power) by the applied card combination is displayed. (Screen 4)



Screen 4

- ⑥ Before starting the battle, players choose whether or not to receive game instructions. (Screen 5)
- ⑦ The battle begins. The player duels with the opponent's dinosaur in a rock-scissors-paper game by pressing a hand-gesture input button (rock, paper, or scissors) within the battle countdown. (Screen 6)



Screen 5

NOTE : During the One-Player Mode a helper character (Dr. Taylor) appears with hints to help the player win.



Screen 6

- ⑧ The dinosaur which wins at rock-scissors-paper will then attack with the move with which they won. The action taken and its strength vary depending on the move. (Screen 7-1)

- Won with Rock → Attacks with a Rock Move
- Won with Scissors → Attacks with a Scissors Move
- Won with Paper → Attacks with a Paper Move

NOTE : If a Super Move Card has been scanned, a special animation will occur. (Screen 7-2)



Screen 7-1



Screen 7-2

- ⑨ The attacked dinosaur will lose health. After repeatedly exchanging attacks, the first dinosaur to eliminate all of its opponent's health is the winner. (Screen 8)



Screen 8

- ⑩ Game Over

- In One-Player Mode, players can clear the game if they defeat the four opponent dinosaurs from levels 1 to 4. On the other hand, if they are defeated by an opponent dinosaur during the course of play, this will result in "Game Over." There is no option to "Continue." (Screen 9)
- In Two-Player Mode both players enter 1 dinosaur each, and the first to defeat their opponent's dinosaur twice is the winner. (Screen 10)

NOTE: The number of matches played in Two-Player Mode can be changed in Test Mode.



Screen 9



Screen 10

Using Dinosaur King Cards

There are three types of card that can be dispensed; Dinosaur Cards, Move Cards and Super Move Cards.

<Dinosaur Card>

These Cards are black. Using a Dinosaur Card allows the dinosaur depicted on it to be used in battle.

<Move Card, Super Move Card>

These Cards are orange. There are two types, Move Cards and Super Move Cards. Using these cards allows the dinosaur to learn the card's technique and increase the dinosaur's power.

- Up to 3 Move Cards or Super Move Cards may be used at once, one Rock Move, one Scissors Move and one Paper Move.
- The amount of increased power granted to the dinosaur depends on the combination (compatibility) of Dinosaur Cards and Move Cards (or Super Move Cards).

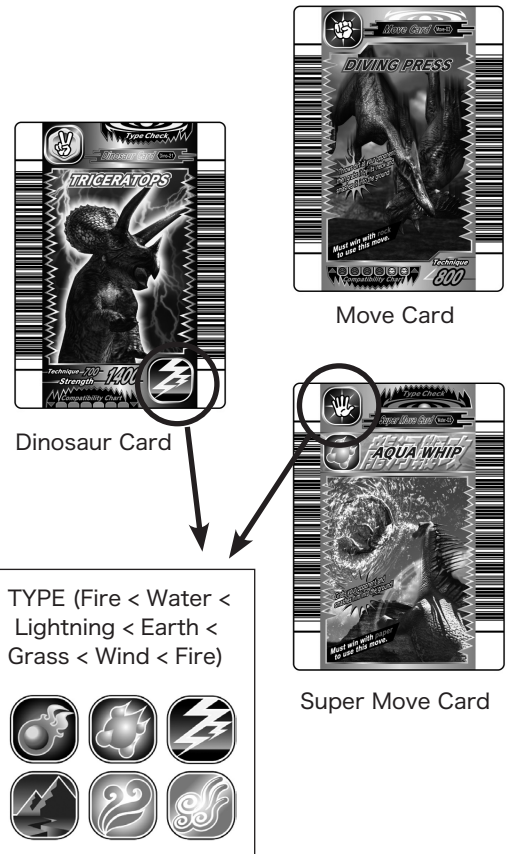

9

① Move Card: Can be used by all dinosaurs.

The higher the “Technique” value of a dinosaur on a Dinosaur Card, the more difficult (as in hard to perform, but powerful) attacks they may unleash.

NOTE : The “Compatibility Chart” at the foot of each card is a quick reference of the compatibility (how much the dinosaur will power-up from Move Cards) of the dinosaur.



Place the “Compatibility Chart” at the bottom of a Dinosaur Card and Move Card together and look at the symbols on the Move Card corresponding to the colors on the Dinosaur Card.
(Crying Face: Bad, Normal Face: Good, Smile Mark: Very Good)

② Super Move Card: Powerful, super techniques (Super Move) that can only be used by dinosaurs of the same type.

NOTE : The “Type Check” at the top of each card displays whether or not the dinosaur can use that Super Move.



If the color of the “Type Check” at the top of the Dinosaur Card and Super Move Card is the same, then that dinosaur can use that Super Move.

10. SystemSP BOARD

10-1 EXTERNAL VIEW

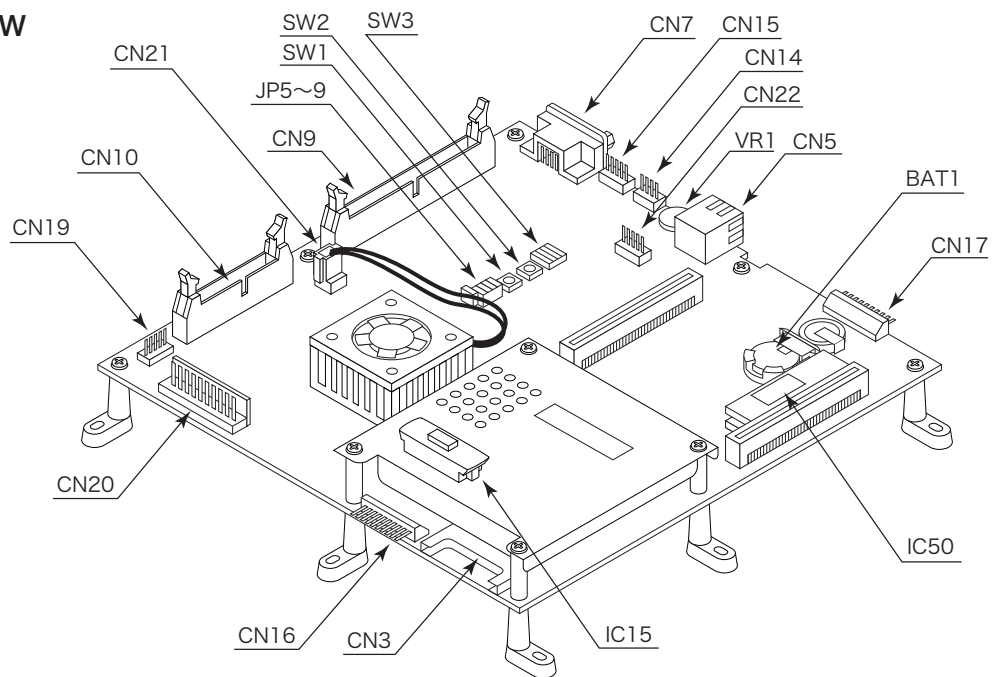

FIG. 10.1 SystemSP Board External View

Parts of CN3 to CN22 are used differently depending upon the game title.
See the “Wiring Diagram” at the back of this manual.

- CN 3 : Compact Flash™* card slot
- CN 5 : Ethernet
- CN 7 : RGB video output (MINI D-SUB 15P)
- CN 9 : Input/output 1 (JST RA 60P)
- CN10 : Input/output 2 (JST RA 30P)
- CN14 : Speaker output (JST NH 4P)
1: L+ 2: L- 3: R+ 4: R-
- CN15 : Sound effects line output (JST NH 5P)
1: GND 2: L 3: GND 4: R 5: GND
- CN16 : Serial 1 (JST NH 10P)
- CN17 : Serial 2 (JST NH 11P)
- CN19 : Input/output 3 (JST NH 7P)
- CN20 : DC power input (JST VH 10P)
1: +3.3V 2: +3.3V 3: +5V 4: +5V 5: +12V
6: +12V 7: GND 8: GND 9: GND 10: GND
- CN21 : Fan power supply (JST NH 3P)
- CN22 : MIDI (JST NH 6P)
- SW1 : Functions as the TEST Button.
- SW2 : Functions as the SERVICE Button.
- SW3 : Used to change the frequency of the video, etc.
See the next chapter “Monitor Placement and Horizontal Scanning Frequency.”
- VR1 : Sound volume
- BAT : Backup battery
- IC15 : Key Chip
- IC50 : SystemSP boot ROM
- JP5 to 9 : The locations into which these are inserted must not be changed. If they are, not only may normal operation be impeded and be serious malfunction may occur.

*Compact Flash and its abbreviation CF are registered trademarks of SanDisk Corporation.

10—2 MONITOR PLACEMENT AND HORIZONTAL SCANNING FREQUENCY

Monitor Placement

Change the Monitor Placement (horizontal, vertical) to suit the game being used.

If there is no mention of the correct placement for the monitor in the documentation provided with the game the monitor should be set to horizontal.

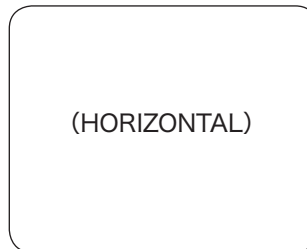

Horizontal Scanning Frequency: 15.85kHz/31.69kHz

Depending upon the game either a frequency 15k or 31k Hz will be supported, or in some cases both.

Use the DIP SW (Dip Switch) 3 on the SystemSP board to specify the frequency output.

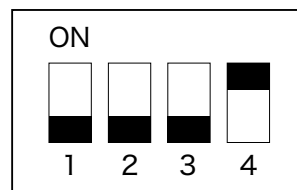

DIP SW 3 OFF: 31kHz

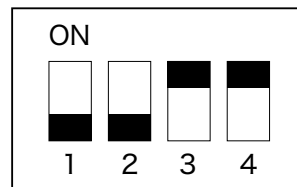

DIP SW 3 ON: 15kHz

Even if both 15k and 31k are supported always leave DIP SW 1 and 2 OFF, and 4 ON unless otherwise instructed to do so.

FIG. 10.2

SystemSP board DIP SW (The actual DIP SW layout may differ slightly from the above diagrams.)

Be aware that an interlaced display may cause a minor amount of flicker or image shaking to occur compared to a non-interlaced display.

Also, if the cabinet's monitor does not support an interlaced display, noise on the screen or other display errors may occur.

Among those games that support both 15k/31k, some are strongly recommended to be run at 31k. If these games are run at 15K, a warning message will be displayed when the game starts up.

When a SystemSP board is initially shipped the DIP SW may be set to 15k or 31k depending upon the enclosed game. Before placing the board into the cabinet, be sure to check the DIP SW and perform any changes if necessary.

**This game requires DIP SW 1 and 2 to be OFF, and 3 and 4 to be ON.
This game runs at 15k.**

10-3 ERROR MESSAGES

The following messages may appear upon turning on the power or leaving TEST Mode. Under these circumstances the game cannot be played. The error codes are roughly divided as follows.

Error Code	Category
Error 01~09	An error relating to the actual hardware or setup of the title program
Error 10~19	An error relating to something dependant upon the title program, such as JVS or the Firmware version.
Error 20~29	(Not used)
Error 30~39	An error relating to the Ether-network
Error 40~49	(Not used)
Caution 50~59	A warning related to set-up settings

TABLE 10.3: Error Code Categories

Error 01

Message:	THIS GAME IS NOT ACCEPTABLE BY MAIN BOARD.
Cause:	1) The title program in the flash memory on the SystemSP board is corrupted. 2) The Key Chip may not match the title program on the SystemSP board.
Solution:	1) If you have a CF memory including renewal data for the title program, insert that CF memory and then restart the machine. 2) Insert the correct Key Chip and then restart the machine. If the problem remains it is most likely a problem with the board itself. Use the instructions in the “Game Board” chapter to remove the SystemSP board and repair it along with the Key Chip.

Error 03

Message:	BAD SERIAL NUMBER ON MAIN BOARD.
Cause:	The SystemSP board’s serial number is incorrect.
Solution:	This is a problem with the SystemSP board. Use the instructions in the “Game Board” chapter to remove the SystemSP board and repair it along with the Key Chip.

Error 05

Message:	THIS GAME IS NOT ACCEPTABLE BY MAIN BOARD.
Cause:	The SystemSP board set-up does not match with the set-up required by the title program.
Solution:	This game cannot be used. Use a different game.

Error 14

Message:	NETWORK FIRMWARE DOES NOT FULFILL THE GAME SPEC.
Cause:	The SystemSP board’s firmware does not fulfill the specifications required by the title program.
Solution:	After confirming the specifications required by the title program, obtain firmware that meets these specifications and renew the firmware.

Error 33

Message:	GATEWAY IS NOT FOUND.
Cause:	Communication with the gateway server was not possible (for a couple of minutes).
Solution:	<ul style="list-style-type: none">• Perform a system test to make sure the network settings are all correct.• The gateway server may not be active.

Error 34

Message:	GATEWAY CANNOT BE FOUND.
Cause:	Communication with the gateway server is not possible.
Solution:	The UTP cable is not connected.

Caution 51

Message:	WRONG VIDEO OUTPUT SETTING OF HORIZONTAL SCANNING FREQUENCY.
Cause:	The title program does not support the current monitor resolution.
Solution:	If necessary exchange the connected monitor, and then check the monitor resolution is set correctly (the DIP Switches on the SystemSP board).

Caution 52

Message:	WRONG VIDEO OUTPUT SETTING OF HORIZONTAL/VERTICAL SCREEN.
Cause:	The title program does not support the current monitor horizontal/vertical setting.
Solution:	If necessary change the horizontal/vertical placement of the monitor, and then enter the SYSTEM TEST Mode in SYSTEM ASSIGNMENTS and change the monitor horizontal/vertical settings.



IMPORTANT

The ROM is a precision device. It can be damaged by heat, impact, and static electricity. Exercise caution in handling this equipment.

This operation must only be performed when changing the boot ROM version, and never at any other time.

- ① Use the special IC removal tool to remove the boot ROM (IC50) from its socket on the SystemSP board.
Although it may appear that a flat head screwdriver or other tool could perform this task, never use anything other than the special IC removal tool. Any marks or scratches caused to the pattern on the board may lead to malfunctions. All repairs will have to be paid for in full for any malfunctions caused by performing this operation with a tool other than the special IC removal tool will have to be paid for in full.

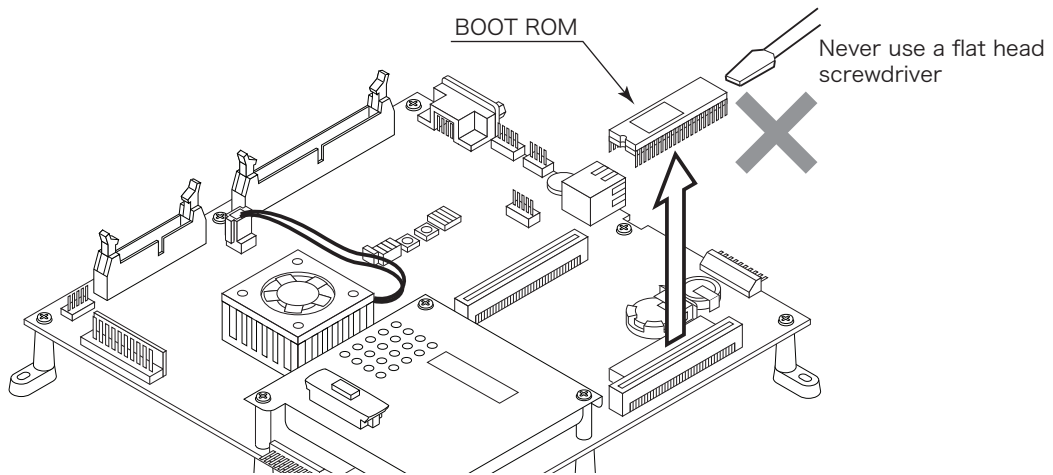

FIG. 10.4a

- ② Make sure you have the facing correct and insert the new ROM into the socket.

- Newer ROM models have slightly wider feet. If this makes it difficult to insert the ROM into the socket, press the flat face of the feet inwards to allow the ROM to be inserted.
- When inserting the ROM pay close attention to direction and be careful not to break the feet.

NOTE : If the power is turned under any of these conditions the ROM may break.

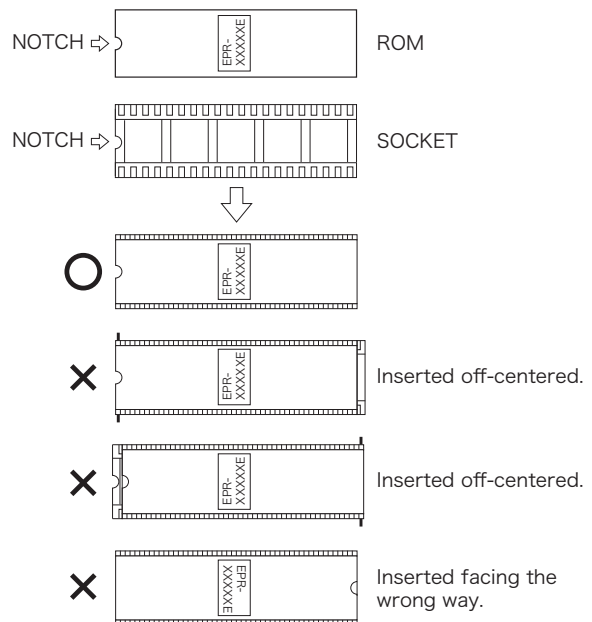

FIG. 10.4b

10—5 REMOVING THE LITHIUM BATTERY



- When working with the product, be sure to turn the power off. Working with the power on may cause an electric shock or short circuit.
- Be careful not to damage wiring. Damaging wiring may cause electric shock or short circuit.
- To prevent overheating, explosion, or fire:
 - Do not recharge, disassemble, heat, incinerate, or short the battery.
 - Do not allow the battery to come into direct contact with metallic objects or other batteries.
 - To preserve or to dispose of the battery, wrap it in tape or other insulating material.
- Follow local regulations when disposing of the battery. Improper disposal can damage the environment.



- To avoid risk of malfunction and damage:
- Make sure the positive and negative ends are aligned correctly.
 - Use only batteries approved for use with this unit.

10



IMPORTANT

If this error appears within one year then it is a problem with the board itself. The board must be replaced.

This operation must only be performed when the battery is dead or under other special circumstances and never at any other time.

- ① Carefully remove the battery in the battery holder (BAT1) on the SystemSP board.
- ② Place the new battery (CR2032) into the holder with the + terminal facing upwards.

SystemSP Battery

- SEGA PART No.:
401-0054 or 401-0065
- SEGA PART NAME:
BATTERY CR2032/1F MATSUSHITA
or
BATTERY CR2032 HITACHIMAXELL

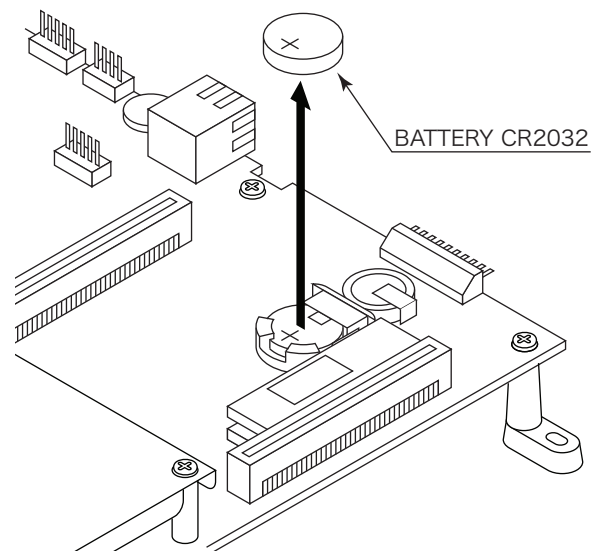

FIG. 10.5

10—6 INSERTION/REMOVAL OF THE LITIUM BATTERY

Insertion

- ① Insert into the holder at a 45 degree angle.
- ② Push horizontally inwards.
The holder is fitting with a device to prevent incorrect insertion, making sure that the battery terminals are inserted correctly.

Removal

- ① Insert a flat, insulated object underneath the battery and lift it upwards.
- ② Bring it up and outwards whilst getting it over the sides of the holder.

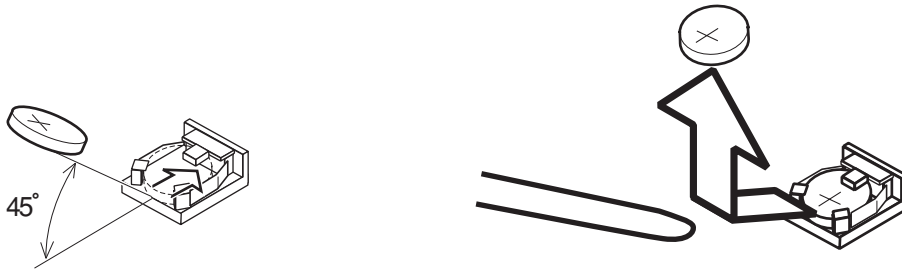

FIG. 10.6



IMPORTANT

The Compact Flash (CF) is a precision device. It can be damaged by heat, impact, and static electricity. Exercise caution in handling this equipment.

Only perform this operation when performing a software upgrade, and never at any other time.

This product uses the SystemSP board. The software upgrade procedure for this board uses Compact Flash.

- ① Open the service door and turn the power switch to OFF.

POWER SWITCH

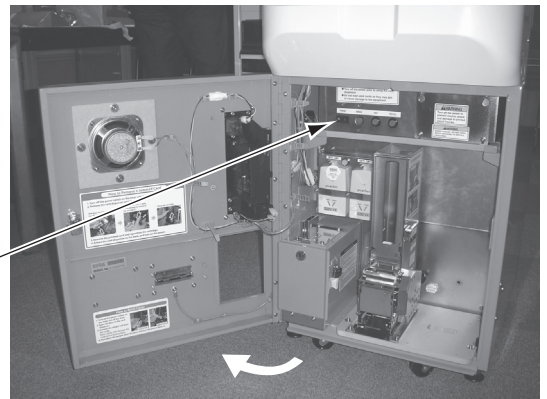

PHOTO10.7a

- ② Loosen the 4 screws on the Compact Flash insertion port cover, slide upward the cover and remove it.



PHOTO10.7b



PHOTO10.7c

- ③ With the game title sticker facing upwards and the correct way around, insert the Compact Flash all the way into the card slot. Be sure that it is as far in as it will go.

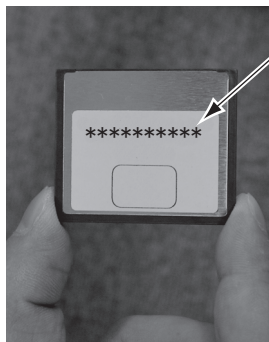

PHOTO10.7d

GAME TITLE



PHOTO10.7e

- ④ Turn the power switch back ON and the software upgrade will begin. The amount of time this will take differs depending upon the volume of the Compact Flash. The software upgrade will proceed as shown in screens ④-1 through to ④-4. If the software upgrade finishes successfully, the Title Screen will be displayed.

④-1



④-2

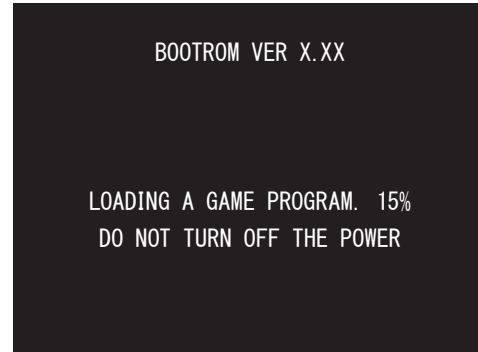

④-3



④-4

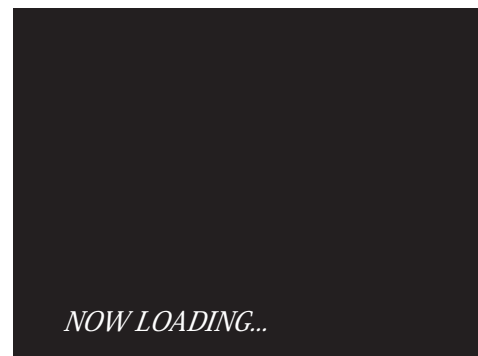

10

Cautions

- After beginning the software upgrade process, do not turn off the power until it has finished.
 - If the software upgrade is not successful, turn the power switch OFF and try reinserting the Compact Flash before turning the power switch ON again. If this still does not resolve the problem, contact your supplier.
- ⑤ Once the software upgrade has been completed successfully turn the power switch OFF, remove the Compact Flash and place it back in its case.
- ⑥ Put the cover back in place removed in step 2, turn the power switch ON and close the service door. The product is ready to be used again.



- The Key Chip is a precision device. It can be damaged by heat, impact, and static electricity. Exercise caution in handling this equipment.
- A Key Chip must be used as a set with a board or Compact Flash of the same title.

Insertion

Insert the Key Chip into the hole on the upper surface of the SystemSP board's plating. Pay attention to the facing of the Key Chip and be sure it is pushed all the way in.

Removal

- ① Press the end of the Key Chip inwards and draw it out from the hole in the SystemSP board's plating.
- ② After removal keep the Key Chip in the box provided. Always store it together with the game board or Compact Flash that it is paired with.

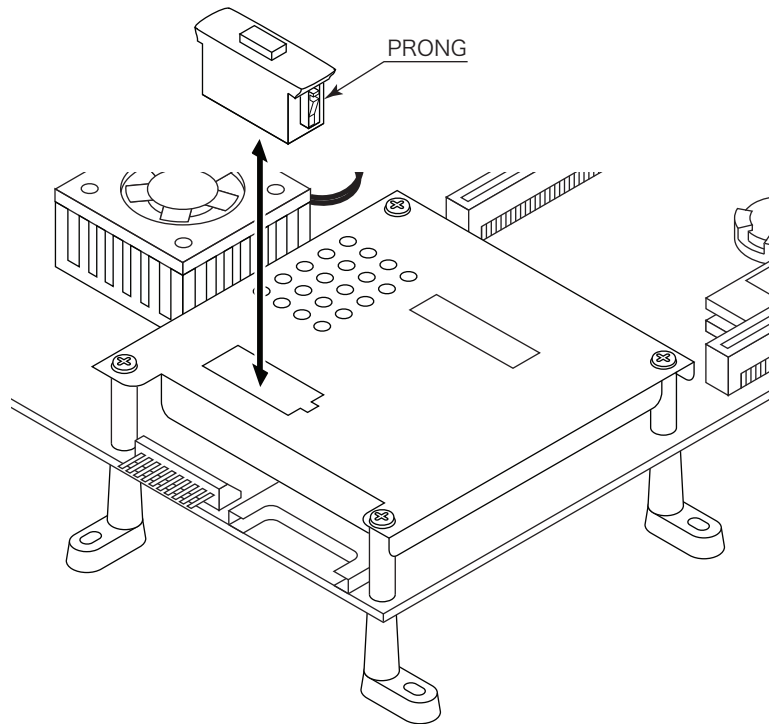

FIG. 10.8

11. EXPLANATION OF TEST AND DATA DISPLAY

By operating the TEST and SERVICE Buttons on the maintenance switch unit, periodically perform tests and data check. When installing the machine for the first time, collecting cash, or when the machine does not function correctly, perform a machine check in accordance with the explanations given in this section.

The chart below shows which test or screen should be used to handle each situation or problem. This product uses the SystemSP board. This system can become play different games simply by overwriting the ROM onboard the SystemSP board or by inserting compact flash.

Therefore this system has two Test Modes. The System Test Mode has numerous common functions for the SystemSP board such as automatic self-diagnostic test and coin settings, whilst the Game Test Mode has an input test for the specific controls for this product.

TABLE 11 EXPLANATION OF TEST MODE

ITEMS	DESCRIPTION	REFERENCE SECTIONS
INSTALLATION OF MACHINE	When the machine is installed, perform the following: 1. Check to ensure each setting is the standard setting at shipment. 2. Check each Input equipment in the INPUT TEST or the CARD READER TEST mode. 3. Check each Output equipment in the OUTPUT TEST or the CARD DISPENSER TEST mode. 4. Test on-IC-Board IC's in the self-test mode.	11-2, 11-3 A 11-4 (2), (6) 11-4 (3), (7) 11-2 C, L
MEMORY TEST	This test is automatically executed by selecting RAM TEST or ROM TEST in the Menu mode.	11-2 C, L
PERIODIC SERVICING	Periodically perform the following: 1. Run Memory Test. 2. Ascertain each setting. 3. Test each Input equipment in the INPUT TEST or the CARD READER TEST mode. 4. Test each Output equipment in the OUTPUT TEST or the CARD DISPENSER TEST mode.	11-2 C, L 11-2, 11-3 A 11-4 (2), (6) 11-4 (3), (7)
CONTROL SYSTEM	1. Check each Input/Output equipment in the Game Test mode. 2. Adjust or replace each Input/Output equipment. 3. If the problem still persists, check each equipment's mechanism movements.	11-4 11-4 Sections 12, 13, 14, 16
MONITOR (CRT)	In the Monitor Adjustment mode, check to see if monitor adjustments are appropriate.	Section 17
IC BOARD	Memory Test.	11-2 C, L

11-1 MAINTENANCE SWITCH UNIT AND COIN METER



WARNING

Never touch places other than those specified. Touching places not specified can cause electric shock and short circuit accidents.



IMPORTANT

- Adjust the sound to an optimal level, taking into consideration the environmental requirements of the installation location.
- Removing the Coin Meter circuitry renders the game inoperable.

Maintenance Switch Unit

Open the service door, and the maintenance switch unit shown will appear. The function of each switch is as follows:

- | | |
|--------------------------------------|--|
| (1) POWER SWITCH:
(POWER) | Switch ON/OFF the power supply. |
| (2) DEMAGNETIZER BUTTON :
(DEMAG) | Eliminates the on-screen color unevenness due to magnetization of CRT. Use this switch first before performing the monitor's color adjustment. |
| (3) TEST BUTTON:
(TEST) | Press to enter Test Mode. Used during Test Mode to confirm or change selections. |
| (4) SERVICE BUTTON:
(SERVICE) | Gives credits without registering on the coin meter. Used during Test Mode to move the cursor. |

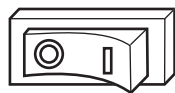

Power switch off.

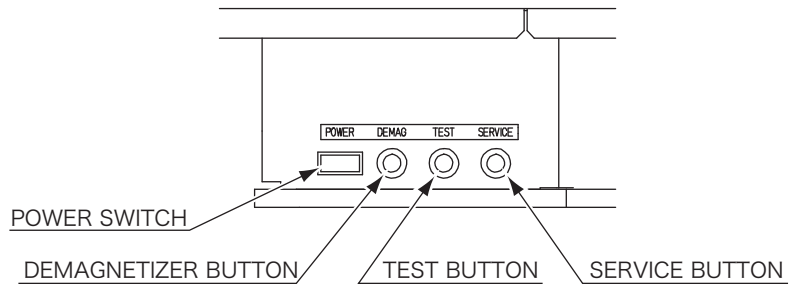

FIG. 11.1a

Coin Meter

Open the Cashbox Door by using the key to have the Coin Meter appear underneath the Cashbox. The Coin Meter counts the number of coins inserted into the coin slot.

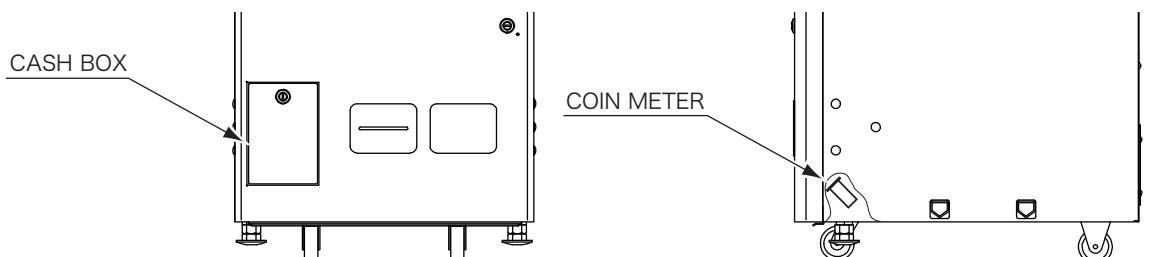

FIG. 11.1b



Any setting altered inside **SYSTEM ASSIGNMENTS**, **COIN ASSIGNMENTS** and **GAME TEST MODE** are saved only when ending Test Mode by selecting **EXIT** from the **SYSTEM MENU**. If the power is turned off before doing this, any alterations to settings will be lost.

SYSTEM MENU

SYSTEM INFORMATION
 RAM TEST
 I/O TEST
 SOUND TEST
 C. R. T. TEST
 SYSTEM ASSIGNMENTS
 ->COIN ASSIGNMENTS
 BOOKKEEPING
 BACKUP DATA CLEAR
 CLOCK SETTING
 ROM TEST
 COMPACT FLASH TEST
 NETWORK SETTING
 GAME TEST MODE
 [*****]
 EXIT

SELECT WITH SERVICE BUTTON
 AND PRESS TEST BUTTON

- ① After turning on the power, press the TEST Button to bring up the SYSTEM MENU, as shown in the figure.
- ② Press the SERVICE Button to move the cursor. Move the cursor down to COIN ASSIGNMENTS and press the TEST Button.
- ③ The COIN ASSIGNMENTS screen will appear. Press the SERVICE Button to move the cursor, and press the TEST Button to select the option highlighted by the cursor.
- ④ Check/alter the coin assignments.
- ⑤ Once settings are complete, move the cursor to EXIT and press the TEST Button. The screen will return to the SYSTEM MENU. Select EXIT again from here and press the TEST Button to return to the game.



COIN ASSIGNMENTS

COIN CHUTE TYPE COMMON

COIN CHUTE #1 COIN TO CREDIT RATE
 1 COIN(S) COUNT AS 1 CREDIT(S)

COIN CHUTE #2 COIN TO CREDIT RATE
 1 COIN(S) COUNT AS 1 CREDIT(S)

->DETAIL SETTING

GAME COST SETTING
 EXIT

SELECT WITH SERVICE BUTTON
 AND PRESS TEST BUTTON

Always set to COMMON.



- The settings changed in Test Mode are stored when Test Mode is ended using EXIT in the menu mode. If the power is turned off before Test Mode is finished, the setting changes do not take effect.
- Executing BACKUP DATA CLEAR in System Test Mode does not clear the bookkeeping data in Game Test Mode.
- Entering Test Mode clears fractional number of coins less than one credit and bonus added data.

A. SYSTEM MENU

System Test Mode can be used to check IC Board functioning, adjust the monitor, and change coin settings.

11

SYSTEM MENU

SYSTEM INFORMATION.....	B
RAM TEST.....	C
I/O TEST.....	D
SOUND TEST.....	E
C. R. T. TEST.....	F
SYSTEM ASSIGNMENTS.....	G
COIN ASSIGNMENTS.....	H
BOOKKEEPING.....	I
BACKUP DATA CLEAR.....	J
CLOCK SETTING.....	K
ROM TEST.....	L
COMPACT FLASH TEST.....	M
NETWORK SETTING.....	N
GAME TEST MODE	
[*****].	(The name of the game will be displayed.)
->EXIT	
SELECT WITH SERVICE BUTTON AND PRESS TEST BUTTON	

Be sure to employ the settings outlined below for this product.

- SYSTEM ASSIGNMENTS
MONITOR TYPE: HORIZONTAL
- COIN ASSIGNMENTS
COIN CHUTE TYPE: COMMON

B. SYSTEM INFORMATION

Check each system program version for the SystemSP board.

```
SYSTEM INFORMATION

REGION      ****
BOOT VERSION ****
FIRM VERSION **** (*****)
SERIAL NO.  ****

PRESS TEST BUTTON TO EXIT
```

- (A)
- (B)
- (C)
- (D)

- (A) REGION
The SystemSP board's region code.
- (B) BOOT VERSION
The SystemSP board's boot program version.
- (C) FIRM VERSION
The SystemSP board's network firmware program version.
- (D) SERIAL NO.
The SystemSP board's serial no.

Press the TEST Button to return to the System Menu screen.

C. RAM TEST

Check the operation of the RAM on the SystemSP board. If everything is operating correctly, "GOOD" will be displayed. If there is a problem, "BAD" will be displayed.

```
RAM TEST

TESTING NOW

IC71 GOOD
IC52S GOOD
IC33S GOOD    IC34 GOOD
IC35 GOOD    IC36S GOOD
IC37 GOOD    IC39 GOOD
IC38S GOOD    IC40S GOOD
IC41 GOOD    IC43 GOOD
IC42S GOOD    IC44S GOOD

PRESS TEST BUTTON TO EXIT
```

- ① The test will begin as soon as you enter this mode.
- ② The message "TESTING NOW" will be displayed during the test.
- ③ After the test is complete, press the TEST Button to return to the System Menu screen.

D. I/O TEST

Check the operation of the switches and connectors connected to the SystemSP board.

```

I/O TEST

SW1      OFF      (A)
SW2      OFF      (A)
TEST     OFF      (B)
SERVICE OFF      (B)
COIN1    OFF      (B)
COIN2    OFF      (B)

COIN METER1 OFF    (C)
COIN METER2 OFF    (C)

IN_PORT0 11111111  (D)
IN_PORT1 11111111  (E)
IN_PORT2 11110011  (F)
G_PORT   11111111  (G)

PRESS TEST AND SERVICE BUTTON TO EXIT
    
```

- (A) Change from OFF to ON when the SW1 and SW2 switches on the SystemSP board are operated.
- (B) Change from OFF to ON when the TEST, SERVICE, COIN1 and COIN2 switches are operated.
- (C) Change from OFF to ON when the COIN1 and COIN2 switches are operated.
- (D) Changes from 1 to 0 when the switch connected to pin 17 to pin 24 of the CN9 is operated.
- (E) Changes from 1 to 0 when the switch connected to pin 41 to pin 48 of the CN9 is operated.
- (F) Changes from 1 to 0 when the DIP switch (SW3) or push switch (SW1, SW2) on the SystemSP board or the switch connected to pin 5 or pin 6 of the CN9 are operated.
- (G) Changes from 1 to 0 when the switch connected to pin 9 to pin 16 of the CN10 is operated.

The “1” and “0” display for (D) to (G) differs depending upon the game title.
Press the TEST Button and SERVICE Button to return to the System Menu screen.

E. SOUND TEST

This mode allows a sound output test to be performed. A beep will be produced from each speaker.

NOTE : Only the LEFT SPEAKER is fitting with a service door for this game.

```

SOUND TEST

RIGHT SPEAKER OFF  (A)
LEFT SPEAKER  OFF  (A)

->EXIT

SELECT WITH SERVICE BUTTON
AND PRESS TEST BUTTON
    
```

- ① Press the SERVICE Button to move the cursor.
- ② Move the cursor to your desired selection and press the TEST Button.
- ③ Move the cursor to EXIT and press the TEST Button to return to the System Menu screen.

- (A) RIGHT/LEFT SPEAKER (ON/OFF)
Turn this option “ON” to produce a beeping noise from that speaker.

F. C.R.T. TEST

This mode allows the monitor color levels and screen size to be checked. However, the hue etc. of colors cannot be altered.

NOTE : Adjustments for this game should be made as detailed in "C.R.T. Test" in "Game Test Mode."

- ① First the monitor color check screen will be displayed.
Each color (red, green and blue) are displayed darkest on the left, getting lighter toward the right in 32 steps.
The monitor is set to the correct brightness level of the white color bar is black on the far left and white on the far right.
- ② Press the TEST Button to proceed to the size check screen.
- ③ Adjust the screen so that the entire check frame is visible.
- ④ Press the TEST Button to return to the System Menu screen.

Color Check Screen

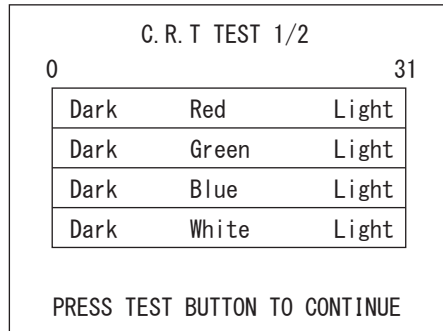

Size Check Screen

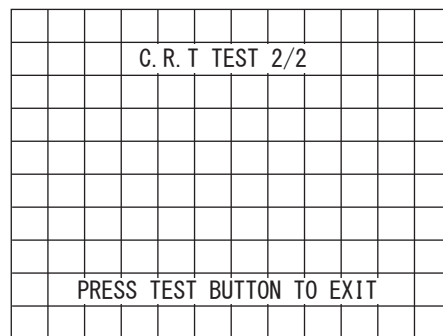

G. SYSTEM ASSIGNMENTS

This mode allows sound during Attract mode and monitor type to be altered.

- ① Press the SERVICE Button to move the cursor.
- ② Move the cursor to your desired selection and press the TEST Button.
- ③ Move the cursor to EXIT and press the TEST Button to return to the System Menu screen.

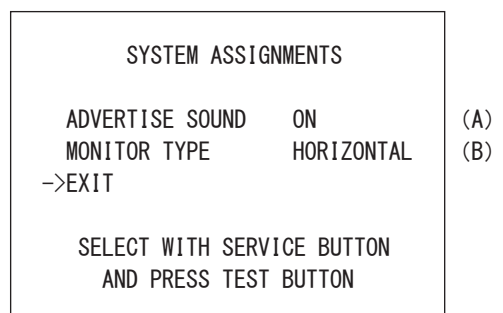

- (A) ADVERTISE SOUND (ON/OFF)
Turn sound during the Attract mode ON or OFF.
ON : Sound will play during Attract mode.
OFF : No sound will play (silent) during Attract mode.
- (B) MONITOR TYPE (HORIZONTAL/VERTICAL)
Change the display of the screen to correspond with monitor type (vertical or horizontal)
HORIZONTAL : For when the monitor is placed horizontally.
VERTICAL : For when the monitor is placed vertically.

H. COIN ASSIGNMENTS

This mode allows the number of credits awarded when a coin is inserted etc. to be altered. The game program will use the settings determined here to manage the number of total number of credits that have been played. Credit settings are saved to the main board when the System Test is ended. If credit settings are changed, the currently recorded number of credits held in back-up will be cleared.

- ① Press the SERVICE Button to move the cursor.
- ② Move the cursor to your desired selection and press the TEST Button.
- ③ Move the cursor to EXIT and press the TEST Button to return to the System Menu screen.

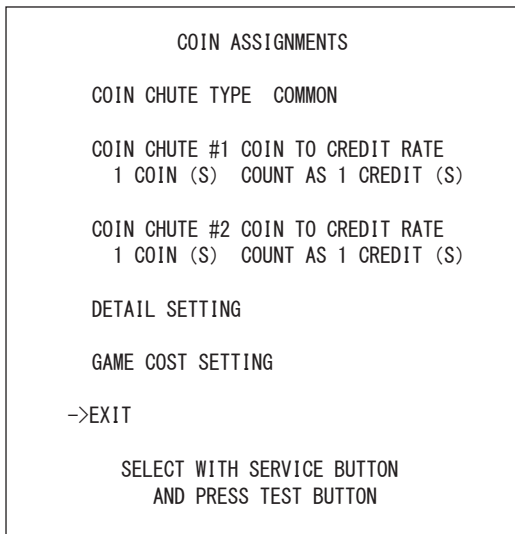

When the COIN CHUTE TYPE is set to "COMMON"

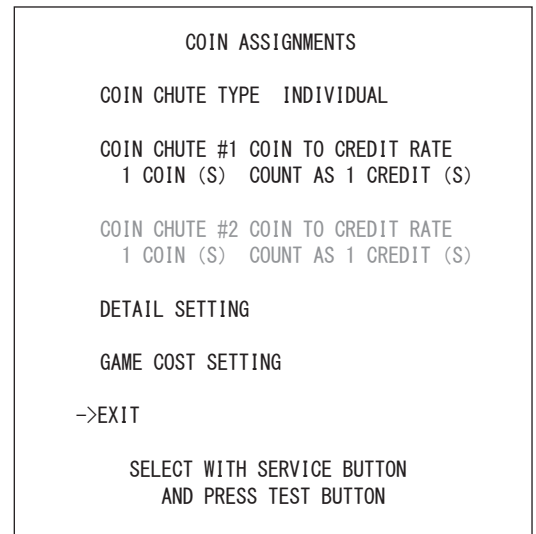

When the COIN CHUTE TYPE is set to "INDIVIDUAL"

(A) COIN CHUTE TYPE (COMMON/INDIVIDUAL)

This must be set to match the cabinet's coin chute system.

COMMON:

Suited to the style of cabinet where multiple players will insert their coins through the same coin chute. Each coin inserted awards one common credit.

Can be used with up to two coin chutes (#1, #2) and (B) COIN CHUTE #* COIN TO CREDIT RATE can be set differently for #1 and #2.

INDIVIDUAL:

Suited to the style of cabinet where each player has an individual coin chute. Each coin inserted awards one credit to that player.

(B) COIN CHUTE #2 COIN TO CREDIT RATE cannot be altered.

(B) COIN CHUTE #1 COIN TO CREDIT RATE, COIN CHUTE #2 COIN TO CREDIT RATE

Determines how many inserted coins count as a credit.

The message "○COIN(S) COUNT AS △CREDIT(S)" displays how many coins equal how many credits. If (A) COIN CHUTE TYPE is set to "COMMON" then the COIN CHUTE #* COIN TO CREDIT RATE for #1 and #2 can be set separately.

See table 1 COMMON and table 2 INDIVIDUAL below for more details.

(C) DETAIL SETTING

This option displays a menu that allows for more detailed coin to credit ratio settings than (B). If these DETAIL SETTING are changed any (B) COIN CHUTE #* COIN TO CREDIT RATE settings are ignored.

- ① Press the SERVICE Button to move the cursor.
- ② Move the cursor to your desired selection and press the TEST Button.
- ③ Move the cursor to EXIT and press the TEST Button to return to the Coin Assignments screen.

COIN ASSIGNMENTS DETAIL SETTING	
COIN CHUTE #1 MULTIPLIER 1 COIN COUNT AS 1 COIN (S)	(C1)
COIN CHUTE #2 MULTIPLIER 1 COIN COUNT AS 1 COIN (S)	(C1)
BONUS ADDER NO BONUS ADDER	(C2)
COIN TO CREDIT 1 COIN (S) 1 CREDIT	(C3)
->EXIT	
COIN CHUTE #1 OPERATION	
COIN 1 2 3 4 5 6 7 8 9	
CREDIT 1 2 3 4 5 6 7 8 9	
COIN CHUTE #2 OPERATION	
COIN 1 2 3 4 5 6 7 8 9	
CREDIT 1 2 3 4 5 6 7 8 9	
SELECT WITH SERVICE BUTTON AND PRESS TEST BUTTON	

When the COIN CHUTE TYPE is set to "COMMON"

COIN ASSIGNMENTS DETAIL SETTING	
COIN CHUTE #1 MULTIPLIER 1 COIN COUNT AS 1 COIN (S)	(C1)
COIN CHUTE #2 MULTIPLIER 1 COIN COUNT AS 1 COIN (S)	(C1)
BONUS ADDER NO BONUS ADDER	(C2)
COIN TO CREDIT 1 COIN (S) 1 CREDIT	(C3)
->EXIT	
COIN CHUTE #1 OPERATION	
COIN 1 2 3 4 5 6 7 8 9	
CREDIT 1 2 3 4 5 6 7 8 9	
COIN CHUTE #2 OPERATION	
COIN 1 2 3 4 5 6 7 8 9	
CREDIT 1 2 3 4 5 6 7 8 9	
SELECT WITH SERVICE BUTTON AND PRESS TEST BUTTON	

When the COIN CHUTE TYPE is set to "INDIVIDUAL"

(C1) COIN CHUTE #1 COIN TO CREDIT RATE, COIN CHUTE #2 COIN TO CREDIT RATE

Determines how many inserted coins count as a credit.

The message "○COIN(S) COUNT AS △CREDIT(S)" displays how many coins equal how many credits. If (A) COIN CHUTE TYPE is set to "COMMON" then the COIN CHUTE #* COIN TO CREDIT RATE for #1 and #2 can be set separately.

See table 3 COMMON and table 4 INDIVIDUAL below for more details.

(C2) BONUS ADDER

Determines the settings for awarding a bonus credit after a certain number of coins are converted by (B) COIN CHUTE #* COIN TO CREDIT RATE. If (A) COIN CHUTE TYPE is set to "COMMON" the total number of coins inserted into COIN CHUTE #* COIN TO CREDIT RATE #1 and #2 is used in this calculation.

The message "○COIN(S) GIVE △EXTRA COIN(S)" displays how many coins equal an extra credit. NO BONUS ADDER indicates that no bonus credits will be given.

See table 5 below for more details.

(C3) COIN TO CREDIT

Determines how many inserted coins count as a credit. The message "○COIN(S) COUNT AS △CREDIT(S)" displays how many coins equal how many credits. E.g. if this is set to 3 and C1 is set to 1, each inserted coin will award 1/3 of a credit. See table 6 below for more details.

(D) GAME COST SETTING

Determines the number of credits needed to start the game and the number needed to continue after game over. The numbers that can be set here differ depending upon the game.

*NOTE : This game does not have the (D2) 1 CREDIT(S) TO CONTINUE option.
Only (D1) 1 CREDIT(S) TO START applies.*

- ① Press the SERVICE Button to move the cursor.
- ② Move the cursor to your desired selection and press the TEST Button.
- ③ Move the cursor to EXIT and press the TEST Button to return to the Coin Assignments screen.

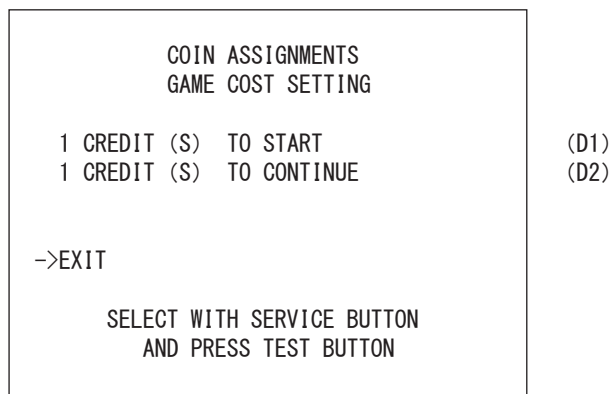

(D1) 1 CREDIT(S) TO START (Default Setting)

Determines the number of credits required to start the game. There are nine possible settings, from 1 CREDIT(S) TO START up to 9 CREDIT(S) TO START.

(D2) 1 CREDIT(S) TO CONTINUE (Default Setting)

Determines the number of credits required to continue the game after game over.

There are nine possible settings, from 1 CREDIT(S) TO CONTINUE up to 9 CREDIT(S) TO CONTINUE.

Table 1-1: COIN CHUTE #* COIN TO CREDIT RATE (COIN CHUTE TYPE COMMON)

(If COIN CHUTE #1 is altered then COIN CHUTE #2 will automatically later itself in the same way)

COIN CHUTE #1 COIN TO CREDIT RATE Setting
1 COIN (S) COUNT AS 1 CREDIT (S)
2 COIN (S) COUNT AS 1 CREDIT (S)
3 COIN (S) COUNT AS 1 CREDIT (S)
4 COIN (S) COUNT AS 1 CREDIT (S)
5 COIN (S) COUNT AS 1 CREDIT (S)
1 COIN (S) COUNT AS 2 CREDIT (S)
1 COIN (S) COUNT AS 3 CREDIT (S)
1 COIN (S) COUNT AS 4 CREDIT (S)
1 COIN (S) COUNT AS 5 CREDIT (S)
FREE PLAY

COIN CHUTE #2 COIN TO CREDIT RATE Setting
1 COIN (S) COUNT AS 1 CREDIT (S)
2 COIN (S) COUNT AS 1 CREDIT (S)
3 COIN (S) COUNT AS 1 CREDIT (S)
4 COIN (S) COUNT AS 1 CREDIT (S)
5 COIN (S) COUNT AS 1 CREDIT (S)
1 COIN (S) COUNT AS 1 CREDIT (S)
1 COIN (S) COUNT AS 1 CREDIT (S)
1 COIN (S) COUNT AS 1 CREDIT (S)
1 COIN (S) COUNT AS 1 CREDIT (S)
1 COIN (S) COUNT AS 1 CREDIT (S)
FREE PLAY

Table 1-2: COIN CHUTE #* COIN TO CREDIT RATE (COIN CHUTE TYPE COMMON)

(If COIN CHUTE #2 is altered COIN CHUTE #1 will not change)

COIN CHUTE #1 COIN TO CREDIT RATE Setting
1 COIN (S) COUNT AS 1 CREDIT (S)
2 COIN (S) COUNT AS 1 CREDIT (S)
3 COIN (S) COUNT AS 1 CREDIT (S)
4 COIN (S) COUNT AS 1 CREDIT (S)
5 COIN (S) COUNT AS 1 CREDIT (S)
1 COIN (S) COUNT AS 2 CREDIT (S)
1 COIN (S) COUNT AS 3 CREDIT (S)
1 COIN (S) COUNT AS 4 CREDIT (S)
1 COIN (S) COUNT AS 5 CREDIT (S)
FREE PLAY

COIN CHUTE #2 COIN TO CREDIT RATE Setting
1 COIN (S) COUNT AS 1 CREDIT (S)
1 COIN (S) COUNT AS 2 CREDIT (S)
1 COIN (S) COUNT AS 3 CREDIT (S)
1 COIN (S) COUNT AS 4 CREDIT (S)
1 COIN (S) COUNT AS 5 CREDIT (S)

Table 2: COIN CHUTE #* COIN TO CREDIT RATE (COIN CHUTE TYPE INDIVIDUAL)

COIN CHUTE #1 COIN TO CREDIT RATE Setting
1 COIN (S) COUNT AS 1 CREDIT (S)
2 COIN (S) COUNT AS 1 CREDIT (S)
3 COIN (S) COUNT AS 1 CREDIT (S)
4 COIN (S) COUNT AS 1 CREDIT (S)
5 COIN (S) COUNT AS 1 CREDIT (S)
1 COIN (S) COUNT AS 2 CREDIT (S)
1 COIN (S) COUNT AS 3 CREDIT (S)
1 COIN (S) COUNT AS 4 CREDIT (S)
1 COIN (S) COUNT AS 5 CREDIT (S)
FREE PLAY

COIN CHUTE #2 COIN TO CREDIT RATE Setting
Separate settings cannot be made when set to INDIVIDUAL.

Table 3: DETAIL SETTING (COIN CHUTE TYPE COMMON)

COIN CHUTE #1 MULTIPLIER Setting
1 COIN COUNT AS 1 CREDIT (S)
1 COIN COUNT AS 2 CREDIT (S)
1 COIN COUNT AS 3 CREDIT (S)
1 COIN COUNT AS 4 CREDIT (S)
1 COIN COUNT AS 5 CREDIT (S)
1 COIN COUNT AS 6 CREDIT (S)
1 COIN COUNT AS 7 CREDIT (S)
1 COIN COUNT AS 8 CREDIT (S)
1 COIN COUNT AS 9 CREDIT (S)

COIN CHUTE #2 MULTIPLIER Setting
1 COIN COUNT AS 1 CREDIT (S)
1 COIN COUNT AS 2 CREDIT (S)
1 COIN COUNT AS 3 CREDIT (S)
1 COIN COUNT AS 4 CREDIT (S)
1 COIN COUNT AS 5 CREDIT (S)
1 COIN COUNT AS 6 CREDIT (S)
1 COIN COUNT AS 7 CREDIT (S)
1 COIN COUNT AS 8 CREDIT (S)
1 COIN COUNT AS 9 CREDIT (S)

Table 4: DETAIL SETTING (COIN CHUTE TYPE INDIVIDUAL)

COIN CHUTE #1 MULTIPLIER Setting
1 COIN COUNT AS 1 CREDIT (S)
1 COIN COUNT AS 2 CREDIT (S)
1 COIN COUNT AS 3 CREDIT (S)
1 COIN COUNT AS 4 CREDIT (S)
1 COIN COUNT AS 5 CREDIT (S)
1 COIN COUNT AS 6 CREDIT (S)
1 COIN COUNT AS 7 CREDIT (S)
1 COIN COUNT AS 8 CREDIT (S)
1 COIN COUNT AS 9 CREDIT (S)

COIN CHUTE #2 MULTIPLIER Setting
Separate settings cannot be made when set to INDIVIDUAL.

Table 5: DETAIL SETTING (BONUS ADDER)

BONUS ADDER Setting
NO BONUS ADDER
2 COINS GIVE 1 EXTRA COIN
3 COINS GIVE 1 EXTRA COIN
4 COINS GIVE 1 EXTRA COIN
5 COINS GIVE 1 EXTRA COIN
6 COINS GIVE 1 EXTRA COIN
7 COINS GIVE 1 EXTRA COIN
8 COINS GIVE 1 EXTRA COIN
9 COINS GIVE 1 EXTRA COIN

Table 6: DETAIL SETTING (COIN TO CREDIT)

COIN TO CREDIT Setting
1 COIN (S) 1 CREDIT
2 COIN (S) 1 CREDIT
3 COIN (S) 1 CREDIT
4 COIN (S) 1 CREDIT
5 COIN (S) 1 CREDIT
6 COIN (S) 1 CREDIT
7 COIN (S) 1 CREDIT
8 COIN (S) 1 CREDIT
9 COIN (S) 1 CREDIT

I. BOOKKEEPING

This mode allows total operation time, number of inserted coins, and number of awarded credits to be checked.

BOOKKEEPING	
TOTAL TIME	(A)
*D **H **M **S	
COIN 1	*
COIN 2	*
	(B)
	(B)
TOTAL COIN	*
COIN CREDIT	*
SERVICE CREDIT	*
TOTAL CREDIT	*
	(C)
	(D)
	(E)
	(F)
PRESS TEST BUTTON TO EXIT	

(A) TOTAL TIME

The total time the game has been in operation, (the length of time it has been powered on and not in Test Mode.)

(B) COIN 1/COIN 2

The total number of coins inserted into coin chute 1.
The total number of coins inserted into coin chute 2.

(C) TOTAL COIN

The total number of coins inserted into all coin chutes.

(D) COIN CREDIT

The total number of credits awarded from inserted coins.

(E) SERVICE CREDIT

The total number of credits awarded by the SERVICE Button.

(F) TOTAL CREDIT

The total of coin credits and service credits.

Press the TEST Button to return to the System Menu screen.

J. BACKUP DATA CLEAR

Select BACKUP DATA CLEAR to clear the contents of BOOKKEEPING data.

BACKUP DATA CLEAR
YES (CLEAR)
->NO (CANCEL)
SELECT WITH SERVICE BUTTON
AND PRESS TEST BUTTON

To clear data, use the SERVICE Button to move the cursor to YES (CLEAR) and then press the TEST Button.

When the data has been cleared, the message "COMPLETED" will be displayed.

Press the TEST Button again to return to the System Menu screen.

Move the cursor to NO (CANCEL) and press the TEST Button to return to the System Menu screen without clearing the data.

K. CLOCK SETTING

This mode allows the calendar settings for the SystemSP board to be altered.

```
CLOCK SETTING

2005 11/23 15 : 30 0 WED

YEAR
MONTH
DAY
HOUR
MINUTE
->EXIT

SELECT WITH SERVICE BUTTON
AND PRESS TEST BUTTON
```

- ① Press the SERVICE Button to move the cursor.
- ② Move the cursor to your desired selection and press the TEST Button to increase that value. If YEAR is increased beyond “2030” it will return to “1998.”
- ③ Move the cursor to EXIT and press the TEST Button to return to the System Menu screen.

L. ROM TEST

Check the operation of the ROM on the SystemSP board. If everything is operating correctly, “GOOD” will be displayed. If there is a problem, “BAD” will be displayed.

```
ROM TEST
[ * * * * * ]

MO.   TYPE  RESULT  BYTE  WORD
IC62  128M  GOOD    0123  4567
IC63  128M  GOOD    0123  4567
IC64  128M  GOOD    0123  4567
IC65  128M  GOOD    0123  4567
IC66S 128M  GOOD    0123  4567
IC67S 128M  GOOD    0123  4567
IC68S 128M  GOOD    0123  4567
IC69S 128M  GOOD    0123  4567

PRESS TEST BUTTON TO EXIT
```

←The name of the game will be displayed.

The number of rows displayed varies depending upon the game.

- ① The test will begin as soon as you enter this mode.
- ② After the test is complete, press the TEST Button to return to the System Menu screen.

M. COMPACT FLASH TEST

This mode allows the content of compact flash (CF) to be tested to see if it is viable or not, if CF is detected. “GOOD” in the STATUS column indicates that everything is operating correctly, and “BAD” indicates that there is a problem.

```

COMPACT FLASH TEST

STATUS      CHECK
PROGRESS    37.1%
OPEN ERROR (S)      0
SUM ERROR (S)      0
TOTAL SUM      F94B0425

FILE        1080/2911
*****
FILE SUM    00EB7E88

PRESS TEST BUTTON TO EXIT
    
```

Only displayed whilst checking.

- ① The test will begin as soon as you enter this mode.
- ② After the test is complete, press the TEST Button to return to the System Menu screen.

If CF is not detected or its key chip is not inserted, one of the following screens will be displayed.

```

COMPACT FLASH TEST

COMPACT FLASH NOT READY

PRESS TEST BUTTON TO EXIT
    
```

A game title that does not use CF will displayed this message when started up.

```

COMPACT FLASH TEST

TESTING THIS COMPACT FLASH
IS NOT AVAILABLE

PRESS TEST BUTTON TO EXIT
    
```

If there is a problem with the formatting of the CF’s internal sum data or if the CF does not correspond to the key chip the following screen will be displayed.

```

COMPACT FLASH TEST

THIS COMPACT FLASH
IS NOT ACCEPTABLE

PRESS TEST BUTTON TO EXIT
    
```

N. NETWORK SETTING

This mode allows network settings to be determined and a communication test to be performed. The title program will use the communication settings set here to communicate. Unlike other settings, any changes made to communication settings are saved to the SystemSP board internal communications memory the instant that they are made.

After altering communications settings it is necessary to reset the machine. The new settings will not come into effect until the machine is turned off and restarted, meaning that allowing the program to continue without doing so may cause unforeseen errors to occur.

NOTE : The game does not use a network communication connection. Setting (A) NETWORK TYPE should be set to " NONE."

- ① Press the SERVICE Button to move the cursor.
- ② Move the cursor to your desired selection and press the TEST Button.
- ③ Move the cursor to EXIT and press the TEST Button to return to the System Menu screen.

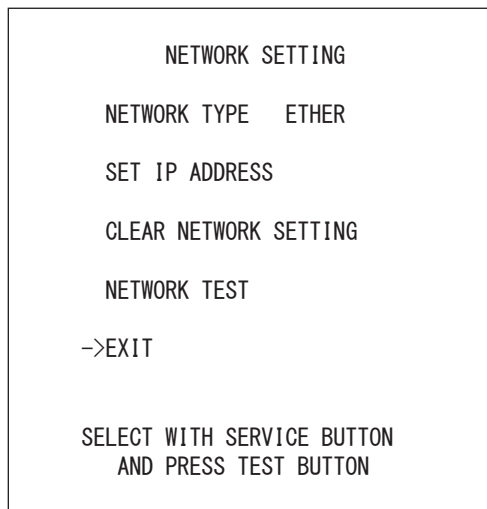

When the NETWORK TYPE is set to "ETHER"

(A)

(B)

(C)

(D)

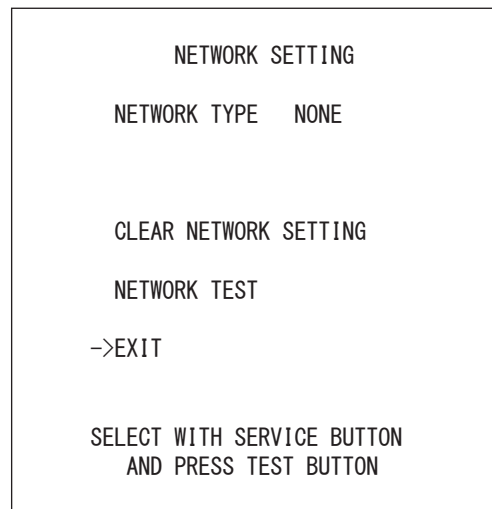

When the NETWORK TYPE is set to "NONE"

(A) NETWORK TYPE

Determines whether or not a communication connection will be used.

NONE: No communication connection will be used. Select this setting when no communication connection will be used.

ETHER: An ETHER communication connection will be used.

(B) SET IP ADDRESS

More detailed settings are required in order to use a communication connection. The content of these settings will vary depending upon the selection made under (A) NETWORK TYPE. Nothing will be displayed if (A) is set to “NONE.”

SET IP ADDRESS	
REMOTE	ENABLE
IP ADDRESS (E)	
-> _ _ . _ . _ . _ . _ . _ . _ .	
SUBNET MASK (E)	
_ . _ . _ . _ . _ . _ . _ . _ .	
GATEWAY (E)	
_ . _ . _ . _ . _ . _ . _ . _ .	
PRIMARY DNS	
0 . 0 . 0 . 0 . 0	SET
SECONDARY DNS	
0 . 0 . 0 . 0 . 0	SET
EXIT	
CURRENT *****	
0 . 0 . 0 . 0	
SELECT WITH SERVICE BUTTON	
AND PRESS TEST BUTTON	

SET IP ADDRESS	
(B1) REMOTE	DISABLE
(B2) IP ADDRESS (E)	
-> _10. 0. 0. 1	
(B3) SUBNET MASK (E)	
255. 255. 255. 0	SET
(B4) GATEWAY (E)	
0. 0. 0. 1	SET
(B5) PRIMARY DNS	
0. 0. 0. 0	SET
(B6) SECONDARY DNS	
0. 0. 0. 0	SET
EXIT	
(B7) CURRENT *****	
(B7) 0. 0. 0. 0	
SELECT WITH SERVICE BUTTON	
AND PRESS TEST BUTTON	

11

- ① Press the SERVICE Button to move the cursor.
If “ENABLE” is selected under REMOTE the “_” for the PRIMARY DNS and SECONDARY DNS settings will move.
If “DISABLE” is selected under REMOTE the “_” for the IP ADDRESS (E), SUBNET MASK (E), GATEWAY (E), PRIMARY DNS and SECONDARY DNS settings will move.
- ② Move the cursor to your desired selection and press the TEST Button.
- ③ Move the cursor to EXIT and press the TEST Button to return to the Network Setting screen.

(B1) REMOTE

Determines automated settings for communication settings.

ENABLE: Communication settings will be retrieved automatically.

DISABLE: Communication settings must be entered manually.

(B2) IP ADDRESS (E)

A setting required for communication, your own IP address.

After inputting the numbers move the cursor to “SET” and press the TEST Button to store the setting.

This cannot be selected when (B1) REMOTE is set to “ENABLE.”

(B3) SUBNET MASK (E)

A setting required for communication, the subnet mask setting.

After inputting the numbers move the cursor to “SET” and press the TEST Button to store the setting.

This cannot be selected when (B1) REMOTE is set to “ENABLE.”

(B4) GATEWAY (E)

A setting required for communication, the gateway setting.

After inputting the numbers move the cursor to “SET” and press the TEST Button to store the setting.

This cannot be selected when (B1) REMOTE is set to “ENABLE.”

(B5) PRIMARY DNS

A setting required for communication, the primary DNS setting.

After inputting the numbers move the cursor to “SET” and press the TEST Button to store the setting.

(B6) SECONDARY DNS

A setting required for communication, the secondary DNS setting.

After inputting the numbers move the cursor to “SET” and press the TEST Button to store the setting.

(B7) CURRENT ***** , * . * . *

The current setting for the selected category.

(C) CLEAR NETWORK SETTING

Return all communication settings to the defaults and selected to not use communication.

(A) NETWORK TYPE will change to “NONE.”

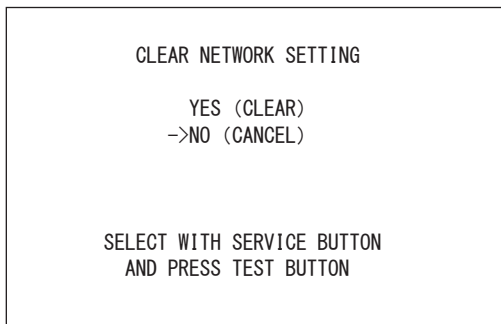

To clear settings, use the SERVICE Button to move the cursor to YES (CLEAR) and then press the TEST Button.

When the settings have been cleared, the message “WRITING DONE” will be blinked.

Press the TEST Button again to return to the Network Setting screen.

Move the cursor to NO (CANCEL) and press the TEST Button to return to the Network Setting screen without clearing the settings.

(D) NETWORK TEST

This mode allows a communication connection test to be performed.

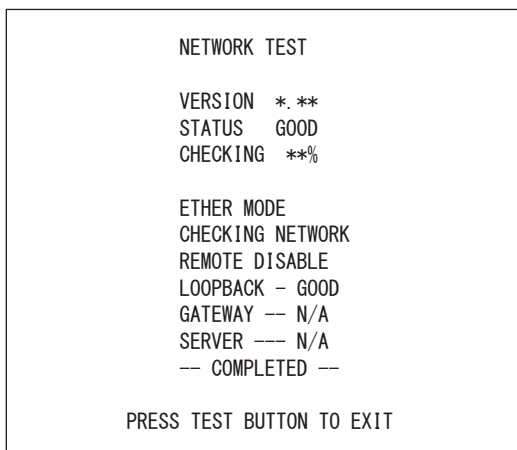

←Only displayed during the test.

←Loopback
←Gateway server
←External server

- ① The test will begin as soon as you enter this mode.
- ② After the test is complete, press the TEST Button to return to the Network Setting screen.

If the test completes successfully the message “GOOD” will be displayed, and “BAD” will be displayed if a problem occurred. If connection is not permitted “N/A” will be displayed. If a test is performed directly after changing settings the results may be incorrect. This test should be performed after turning off and restarting the product.

11-4 GAME TEST MODE

(1) GAME TEST MODE MENU

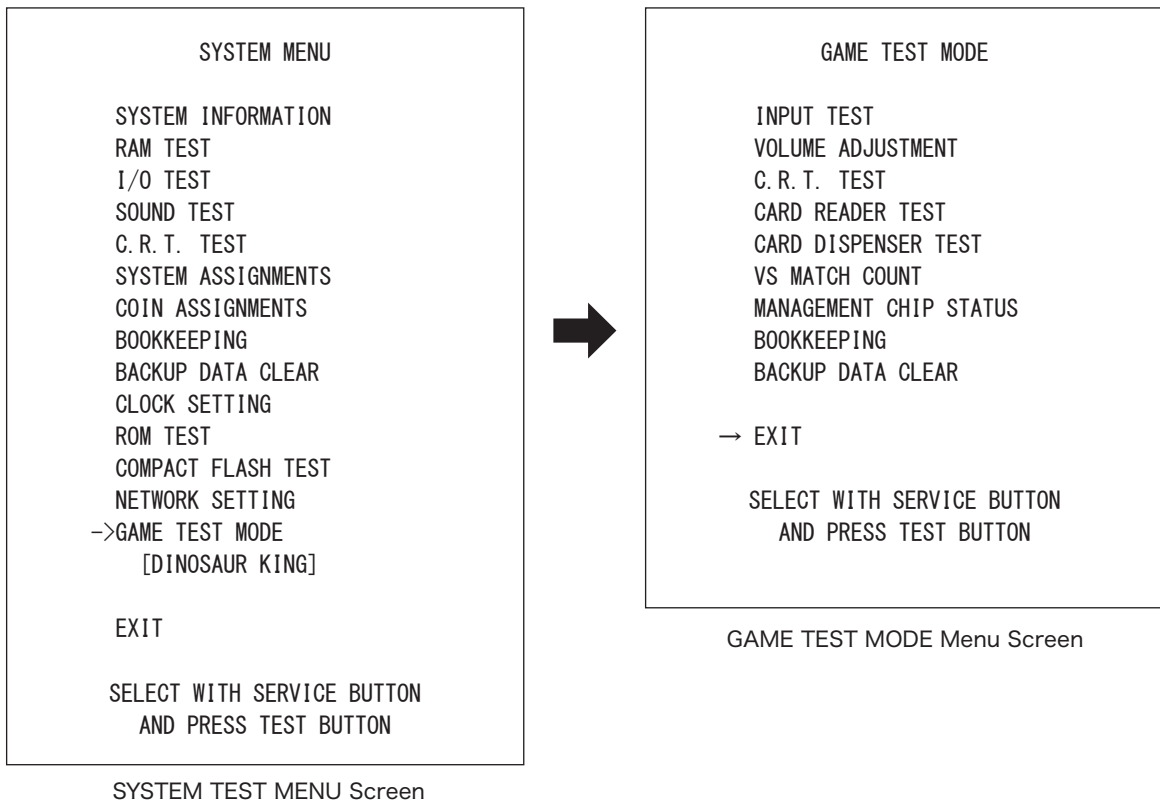

Select GAME TEST MODE from the System Test Menu screen to display the Game Test Menu screen as follows.

Use the SERVICE Button to move the cursor to the desired test item. Press the TEST Button to enter the selected item.

After selecting an item, read the explanations below regarding operation.

After making changes, be sure to select EXIT and press the TEST Button in order to enable the new settings.

Select EXIT and press the TEST Button to end the Game Test Mode and return to the System Test Menu screen. Select EXIT and press the TEST Button again to end System Test Mode and return to the game screen.

(2) INPUT TEST

Select INPUT TEST to display the following screen and check the status of input devices. This test should be run periodically to ensure that each input device is functioning correctly.

The input buttons are functioning correctly if each respective display changes from “OFF” to “ON” when pressing the input buttons.

Press the SERVICE and TEST Buttons simultaneously to return to the Game Test Mode screen.

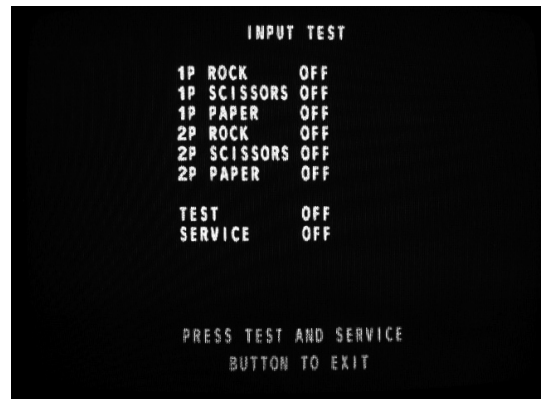

INPUT TEST Screen

(3) VOLUME ADJUSTMENT

Select VOLUME ADJUSTMENT to display the following screen and adjust the sound volume.

Move the cursor to VOLUME and press the buttons on the 1P side to increase the volume, and the buttons on the 2P side to decrease the volume setting.

Volume can be set at a level between 0 and 15.

Move the cursor to EXIT and press the TEST Button to return to the Game Test Mode screen.

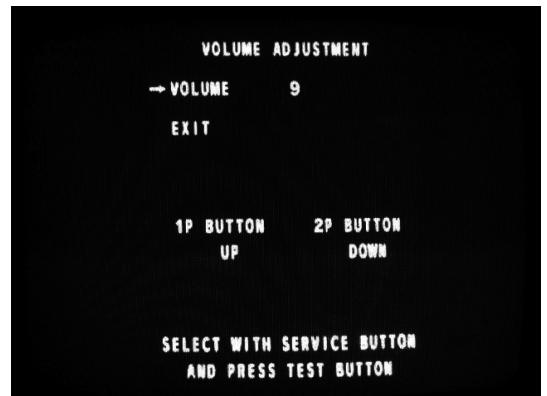

VOLUME ADJUSTMENT Screen

(4) C.R.T. TEST

Select CRT TEST to display the following screen and check the status of the CRT (monitor). This test should be run periodically to check the monitor condition.

Pressing the TEST Button will display the “Color Bar,” “All Black,” and “All White” screens in order. Press the TEST Button again to return to the Game Test Menu screen.

Refer to Section 16, “MONITOR,” for more information on CRT adjustment.

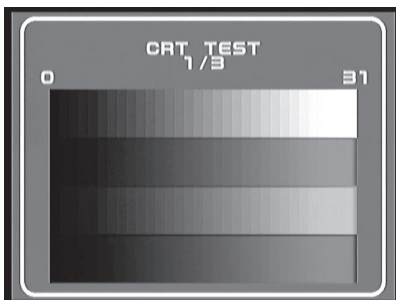

CRT TEST Screen <1/3>



CRT TEST Screen <2/3>

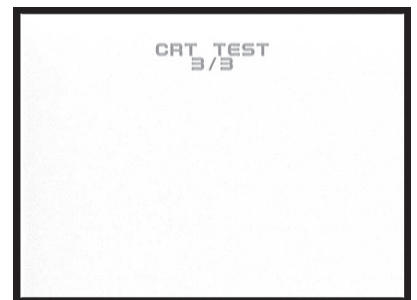

CRT TEST Screen <3/3>

(5) CARD READER TEST

Select CARD READER TEST to display the following screen and check the status of the card reader.

This test should be run periodically to check the condition of the card reader.

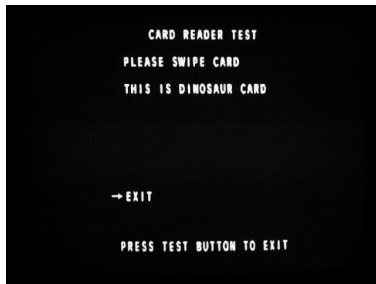

Screen showing a “Dinosaur Card” scan

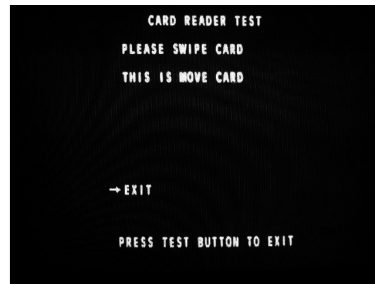

Screen showing a “Move Card” scan

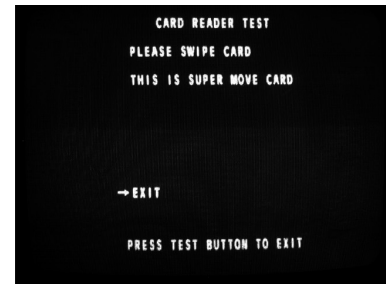

Screen showing a “Super Move Card” scan

Scan a “Dinosaur Card,” “Move Card” or “Super Move Card.” If scanned correctly the above messages will be displayed.

A failed scan, or scanning cards other than those compatible with Dinosaur King, will result in the message “THIS IS UNKNOWN CARD” being displayed.

Press the TEST Button to return to the Game Test Mode screen.

(6) CARD DISPENSER TEST

Select CARD DISPENSER TEST to display the following screen and check the status of the card dispenser.

This test should be run periodically to check the condition of the card dispenser.

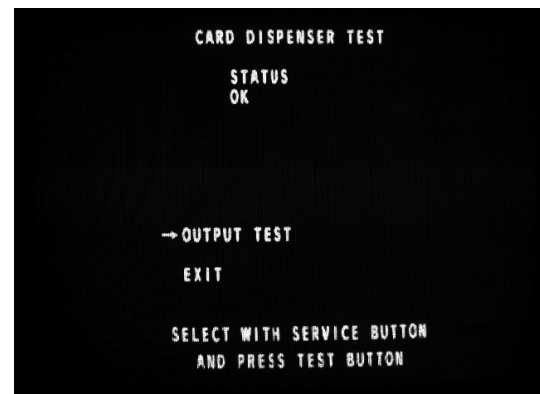

CARD DISPENSER TEST Screen

Move the cursor to OUTPUT TEST and press the TEST Button to dispense the card.

Different STATUS messages will be displayed depending on the operation status of the Card Dispenser.

- “OK”:
It is possible to dispense the card.
- “JAMMED CARD”:
A card is jammed.
- “EMPTY CARD”:
There are no cards in the dispenser.
- “-----”:
There is either no Card Dispenser attached, the dispenser is in the middle of dispensing, or something not listed above has occurred.

Move the cursor to EXIT and press the TEST Button to return to the Game Test Mode screen.

(7) VS MATCH COUNT

Select VS MATCH COUNT to display the following screen, allowing you to change the number of matches played in a 2P VS game.

Move the cursor to WIN 2 and press the TEST Button and the message will change to WIN 1.

Press the TEST Button again to change back to WIN 2.

WIN 1: Victory is decided by a single match

WIN 2: Victory is decided by the first player to 2 wins

Move the cursor to EXIT and press the TEST Button to return to the Game Test Mode screen.

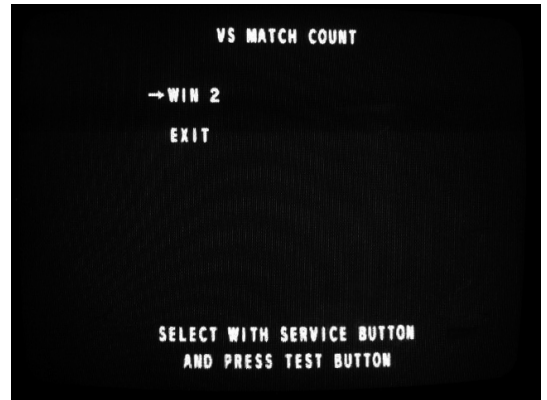

VS MATCH COUNT Screen

11

(8) MANAGEMENT CHIP STATUS

Select MANAGEMENT CHIP STATUS to check the status of the MANAGEMENT CHIP 1 and 2.

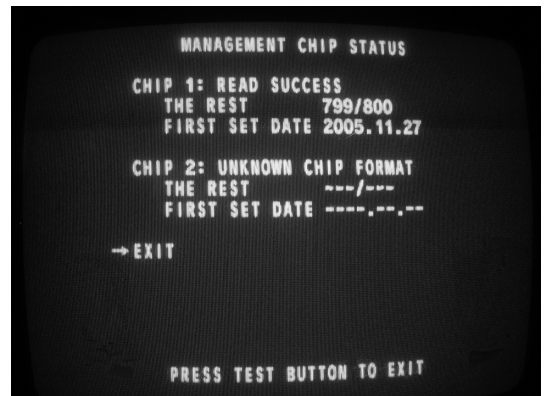

MANAGEMENT CHIP STATUS Screen

● CHIP

If the Management Chip is read correctly, “READ SUCCESS” will be displayed to the right of “CHIP *.”

If an error has occurred then one of the messages below will be displayed instead. See details below for the cause of the error and how to deal with it.

“READER NOT READY”

[CAUSE]

Wiring may be incorrect disconnected, or it could be a hardware malfunction.

[COUNTERMEASURE]

Turn off the power and check the wiring, then turn the power back on. If the problem is still not resolved then the hardware itself is most likely broken. Replace broken parts with new ones.

“READ ERROR”

[CAUSE]

- 1) Wiring may be incorrect disconnected, or it could be a hardware malfunction.
- 2) The Management Chip may not be correctly inserted.

[COUNTERMEASURE]

- 1) Turn off the power and check the wiring then turn the power back on. If the problem is still not resolved then the hardware itself is most likely broken. Replace broken parts with new ones.
- 2) Make sure that the Management Chip is inserted correctly, or remove and reinsert it. The Management Chip may also be damaged. Exchange it with a new chip.

“UNKNOWN CHIP FORMAT”

[CAUSE]

A Management Chip of an unknown type or version has been inserted.

[COUNTERMEASURE]

Check again to confirm that this is the correct chip.

“THIS CHIP IS A UN-PRODUCT”

[CAUSE]

This is a Management Chip that has been used before, but its remaining number of uses has been incorrectly increased.

[COUNTERMEASURE]

Check again to confirm that this is the correct chip.

● THE REST

The remaining number of times this Management Chip can dispense a card is displayed.

● FIRST SET DATE

Displays the Management Chip's initial date of installation.

Press the TEST Button to return to the Game Test Mode screen.

(9) BOOKKEEPING

Select BOOKKEEPING to display the following operating data.

Use the SERVICE Button to move the cursor to the desired test item. Press the TEST Button to enter the selected item. After selecting an item, read the explanations below [(A) ~ (D)] regarding operation.

Move the cursor to EXIT and press the TEST Button to return to the Game Test Menu screen.

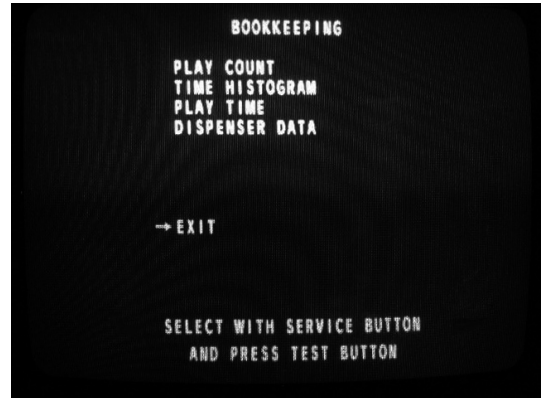

BOOKKEEPING MENU Screen

(A) PLAY COUNT

Select PLAY COUNT to see the following screen and view the number of plays.

- TOTAL COUNT: Total number of plays.
1PLAY COUNT: Total number of single-player plays.
2PLAY COUNT: Total number of two-player plays.
CLEAR COUNT: Number of single-player game completions.

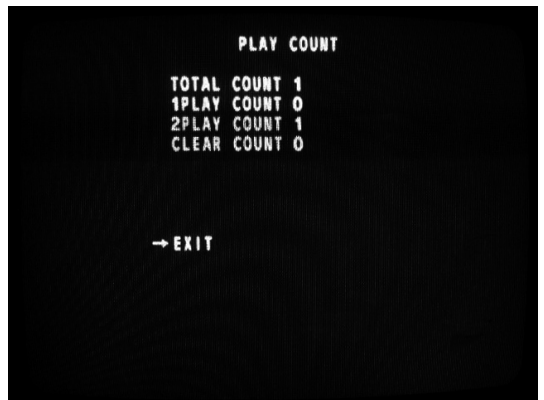

PLAY COUNT Screen

(B) TIME HISTOGRAM

Select TIME HISTOGRAM to see the following screen and check the play count for any given day and time.

Displays how many times the game was played at what time and on which day. Use NEXT to change the day displayed. The total for each day of the week is also calculated.

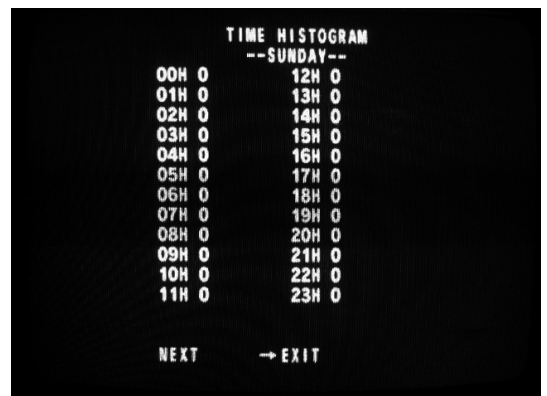

TIME HISTOGRAM Screen

(C) PLAY TIME

Select PLAY TIME to see the following screen and view duration of play.

1P AVR: Average single-player play time.
1P MAX: Longest single-player play time.
1P MIN: Shortest single-player play time.

2P AVR: Average two-player play time.
2P MAX: Longest two-player play time.
2P MIN: Shortest two-player play time.

1P TOTAL PLAY TIME:
Total single-player play time.
2P TOTAL PLAY TIME:
Total two-player play time.
ALL TOTAL PLAY TIME:
Total combined play time.

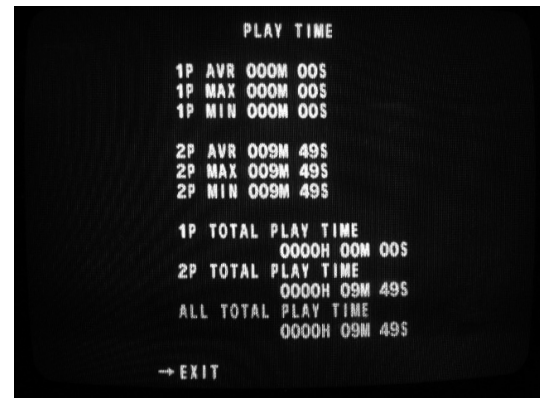

PLAY TIME Screen

(D) DISPENSER DATA

Select DISPENSER DATA to see the following screen and view each Card Dispenser status category.

CARD OUT COUNT:
The number of cards dispensed.
CARD JAMMED COUNT:
The number of jammed cards.
CARD EMPTY COUNT:
The number of "CARD EMPTY" occurrences.

The number of cards dispensed during Test Mode (Card Dispenser Test) is not included in the count.

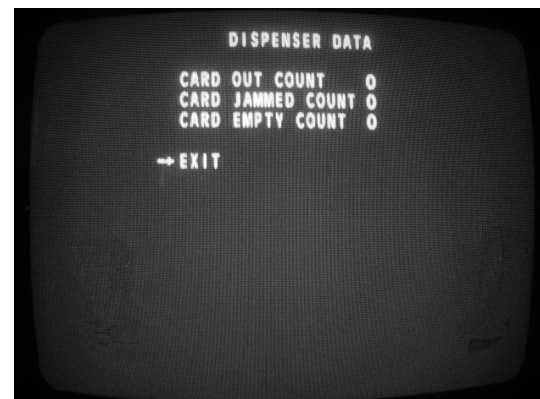

DISPENSER DATA Screen

(10) BACKUP DATA CLEAR

Select BACKUP DATA CLEAR to clear the contents of BOOKKEEPING data in the Game Test Mode.

To clear data, use the SERVICE Button to move the cursor to YES and then press the TEST Button.

When the data has been cleared, the message "COMPLETED" will be displayed. Press the TEST Button again to return to the Game Test Menu Screen.

Move the cursor to NO and press the TEST Button to return to the Game Test Mode screen without clearing the data.

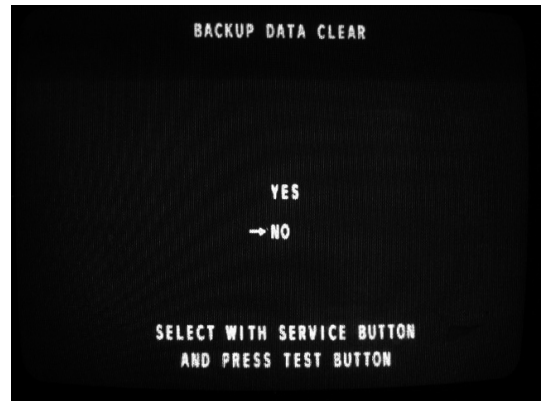

BACKUP DATA CLEAR Screen

12. CARD DISPENSER



- When working with the machine, be sure to turn the power off. Working with the power on can cause an electric shock or a short circuit.
- Be careful not to damage the wires. Damaged wires may cause electric shock, short circuit, or present a risk of fire.
- Do not touch undesignated places. Touching these places can cause electric shock or short circuit.

HOW TO REMOVE THE CARD DISPENSER

- ① Turn off the main AC unit power switch and open the service door.
- ② Unfasten the cord clamp and connector on the cable connected to the card dispenser, and pull the card dispenser forward while pushing down on the lock lever on the lower section of the card dispenser.

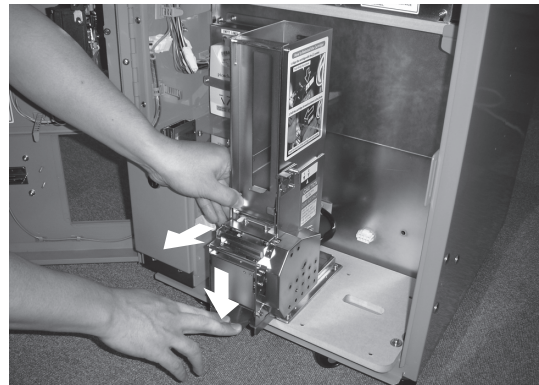

PHOTO12a

- ③ When it cannot be pulled forward any further, lift up on the card dispenser and detach it from the rail.

CONNECTOR

CORD CLAMP

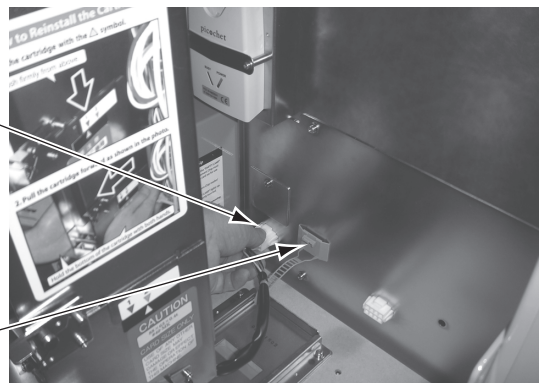

PHOTO12b

CONNECTOR

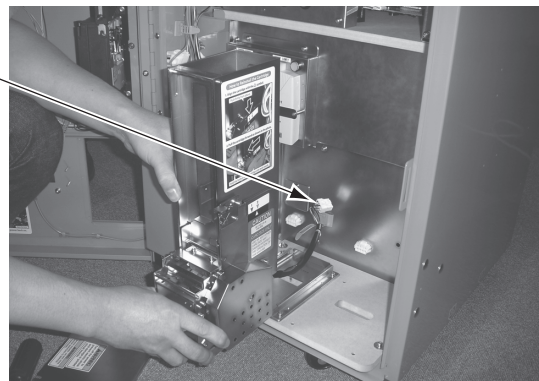

PHOTO12c

13. CARD READER (CONTROL PANEL)



- When cleaning the card reader, always use the designated Cleaning Card.
- Do not use chemical detergents such as “glass cleaner” available on the market or solvents such as thinner, etc.

13-1 HOW TO CLEAN THE CARD READER

- ① Insert the Cleaning Card, aligning the cloth side with the red light in the Card Reader groove.

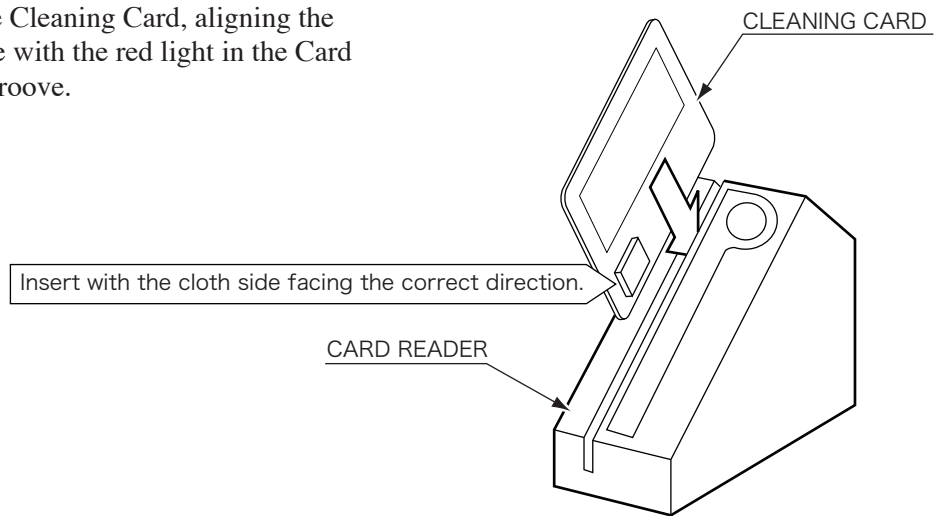

FIG.13.1a

- ② Slowly slide the Cleaning Card up and down to clean off any accumulated dirt.

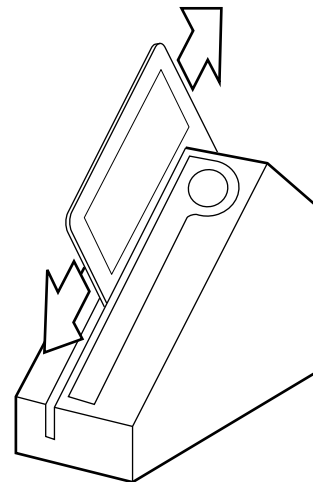

FIG.13.1b

After cleaning, refer to "11-4 Game Test Mode, (5) Card Reader Test" to test the functionality.

13-2 HOW TO REMOVE THE CARD READER (METALLIC TYPE)



- When working with the machine, be sure to turn the power off. Working with the power on can cause an electric shock or a short circuit.
- Be careful not to damage the wires. Damaged wires may cause electric shock, short circuit, or present a risk of fire.
- Do not touch undesignated places. Touching these places can cause electric shock or short circuit.
- Do not attempt to disassemble the card reader unit. Doing so could result in exposure to hazardous laser radiation.
- This work should be performed by the site maintenance individual or another skilled professional. Performing work by non-technical personnel can cause severe accidents such as electric shock.

- ① Turn off the main AC unit power switch.
- ② Remove the 8 tamperproof screws on the control panel.

TAMPERPROOF SCREW (8), chrome
M4×12

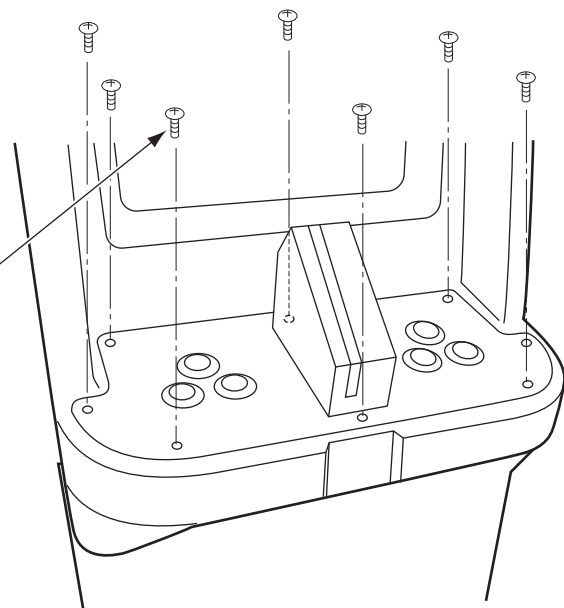

FIG.13.2a

- ③ Being careful not to damage the cord, unplug the connector from the control panel and pull it out of the cabinet.

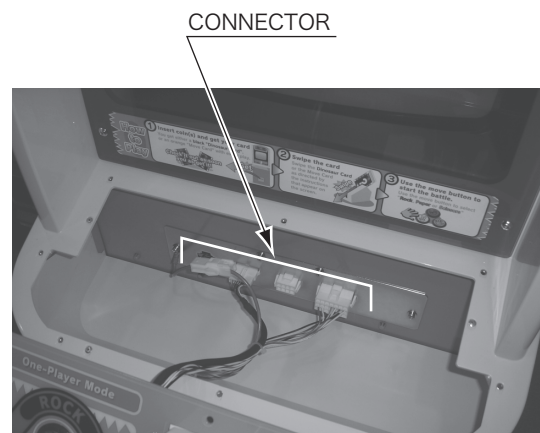

PHOTO13.2a

- ④ Remove the cord clamp and use nippers to cut the 2 tie belts loose.

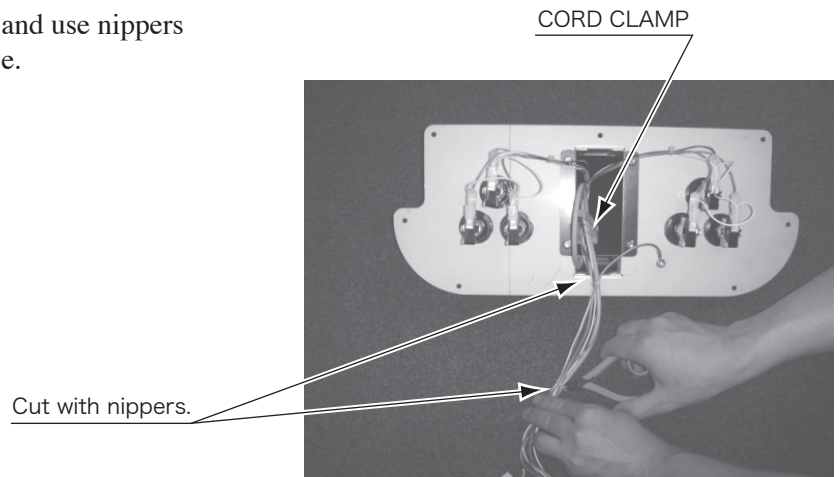

PHOTO13.2b

- ⑤ Unfasten the 4 carriage bolts and 4 flange nuts holding the card reader bracket in place and remove the card reader from the control panel.

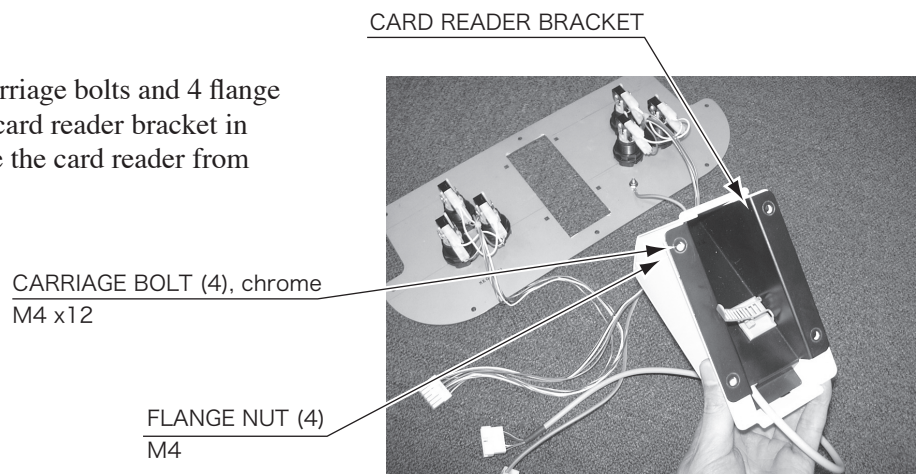

PHOTO13.2c

- ⑥ Remove the card reader cover and detach the card reader from the card reader bracket.

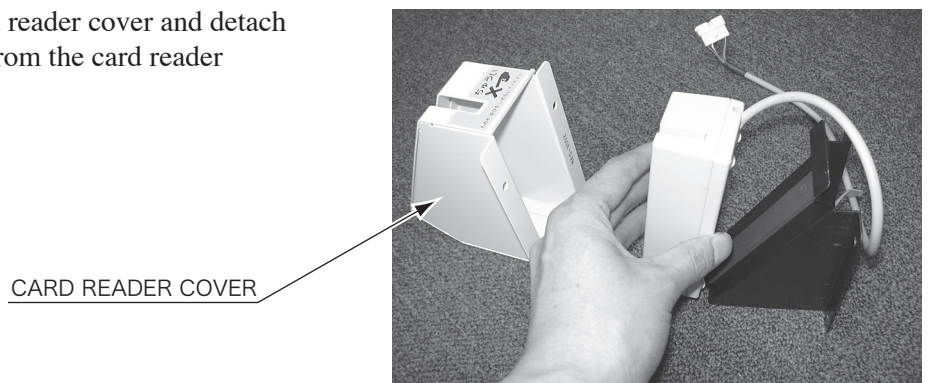

PHOTO13.2d

13-2 HOW TO REMOVE THE CARD READER (MOLDED TYPE)



- When working with the machine, be sure to turn the power off. Working with the power on can cause an electric shock or a short circuit.
- Be careful not to damage the wires. Damaged wires may cause electric shock, short circuit, or present a risk of fire.
- Do not touch undesignated places. Touching these places can cause electric shock or short circuit.
- Do not attempt to disassemble the card reader unit. Doing so could result in exposure to hazardous laser radiation.
- This work should be performed by the site maintenance individual or another skilled professional. Performing work by non-technical personnel can cause severe accidents such as electric shock.

- ① Turn off the main AC unit power switch.
- ② Remove the 8 tamperproof screws on the control panel.

TAMPERPROOF SCREW (8), chrome
M4×12

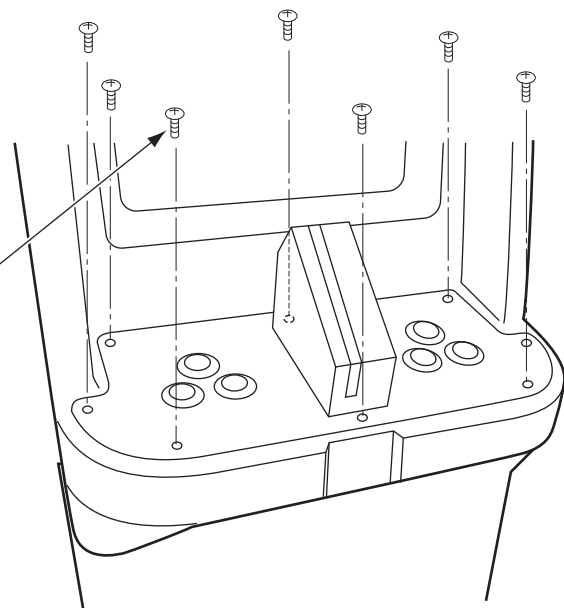

FIG.13.2a

- ③ Being careful not to damage the cord, unplug the connector from the control panel and pull it out of the cabinet.

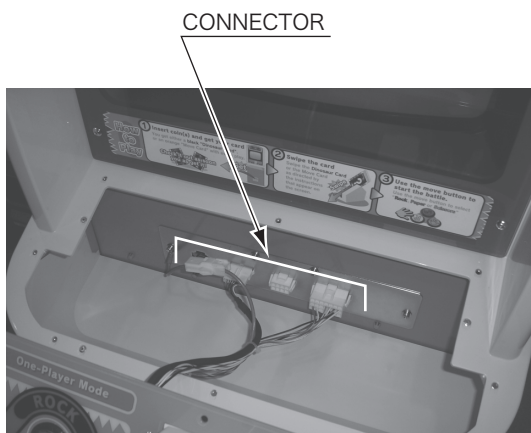

PHOTO13.2a

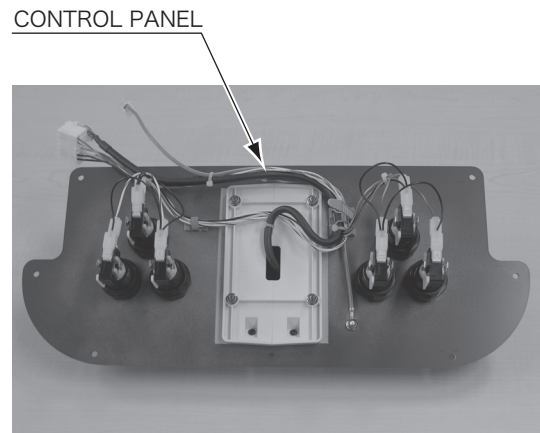

PHOTO13.2b

- ④ Remove the cord clamp and use nippers to cut the 2 tie belts loose.

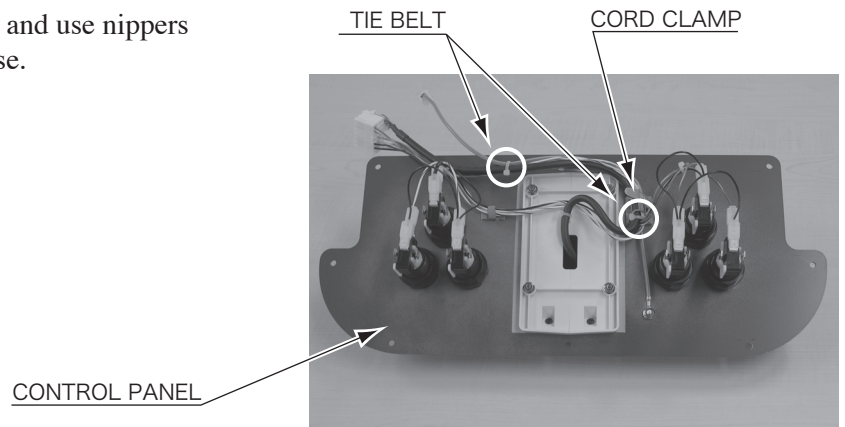

PHOTO13.2c

- ⑤ Unfasten the 4 carriage bolts and 4 flange nuts holding the card reader bracket in place and remove the card reader from the control panel.

CARRIAGE BOLT (4), chrome
M4 x12

FLANGE NUT (4)
M4

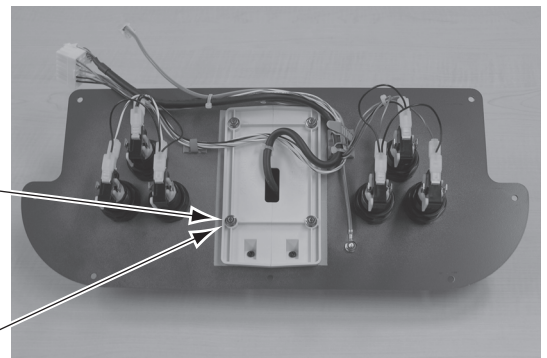

PHOTO13.2d

13

CARD READER

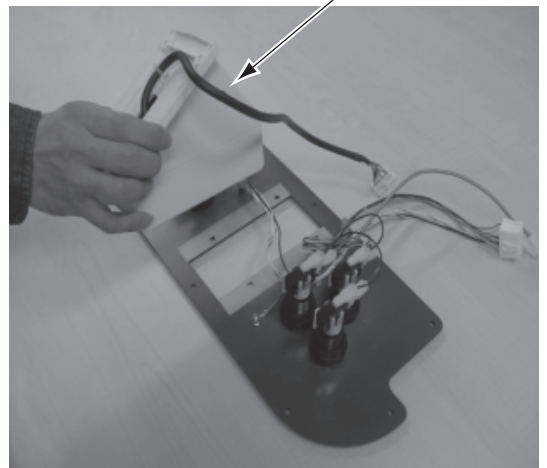

PHOTO13.2e

14. POWER UNIT



- When working with the machine, be sure to turn the power off. Working with the power on can cause an electric shock or a short circuit.
- Be careful not to damage the wires. Damaged wires may cause electric shock, short circuit, or present a risk of fire.
- Do not touch undesignated places. Touching these places can cause electric shock or short circuit.
- This work should be performed by the site maintenance individual or another skilled professional. Performing work by non-technical personnel can cause severe accidents such as electric shock.

14-1 HOW TO REMOVE THE POWER UNIT

- ① Turn off the main AC unit power switch.
- ② Remove the 2 tamperproof screws and detach the back door.

TAMPERPROOF SCREW (2), chrome
M4x8

BACK DOOR

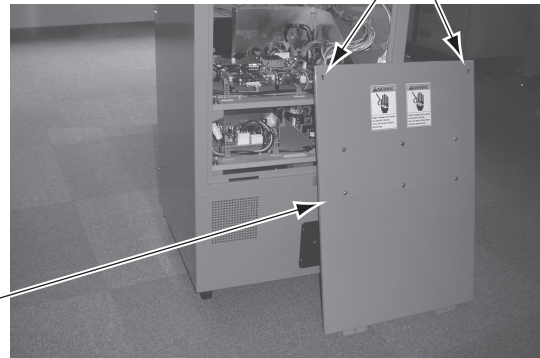

PHOTO14.1a

- ③ Unplug all the connectors (L × 2, R × 1, and an earth wire) plugged into the Power & I/O Board unit.

SCREW (1)
M4 x 8

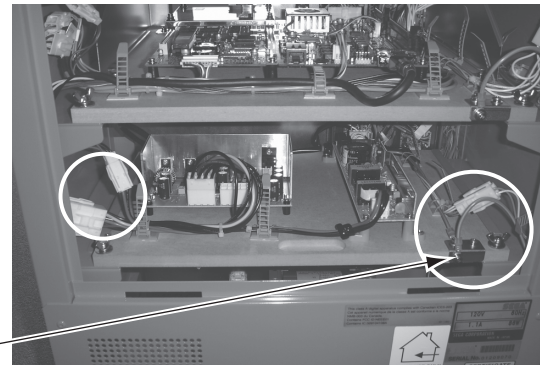

PHOTO14.1b

- ④ Remove the 2 wing bolts and pull out the board.

WING BOLT (2)
M4 x 20, flat washer used

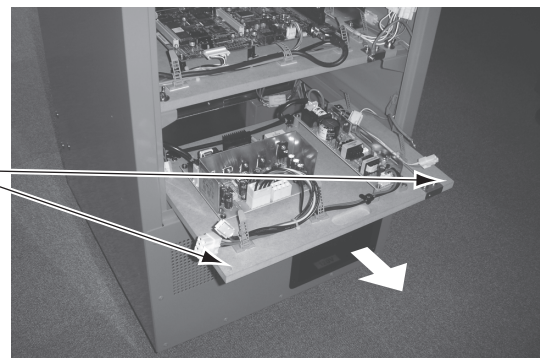
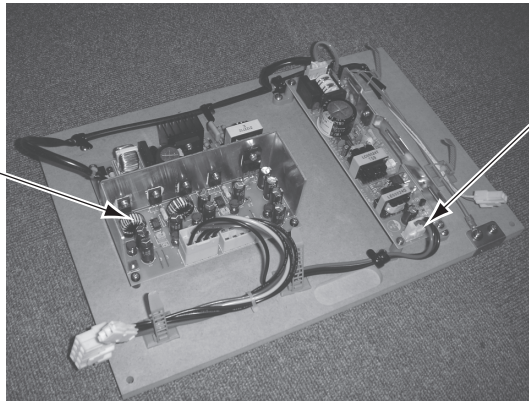

PHOTO14.1c

14—2 COMPOSITION OF THE POWER UNIT

SW REGU 3.3V 4.2A, 5V 4A, 12V 1.5A
400-5458



SW REGU LCA50S-24
400-5421-05024

PHOTO14.2

15. COIN SELECTOR AND BILL ACCEPTOR

REMOVING THE COIN SELECTOR

Loosen the screw to raise the lever and open the coin selector cover and then remove the coin selector.

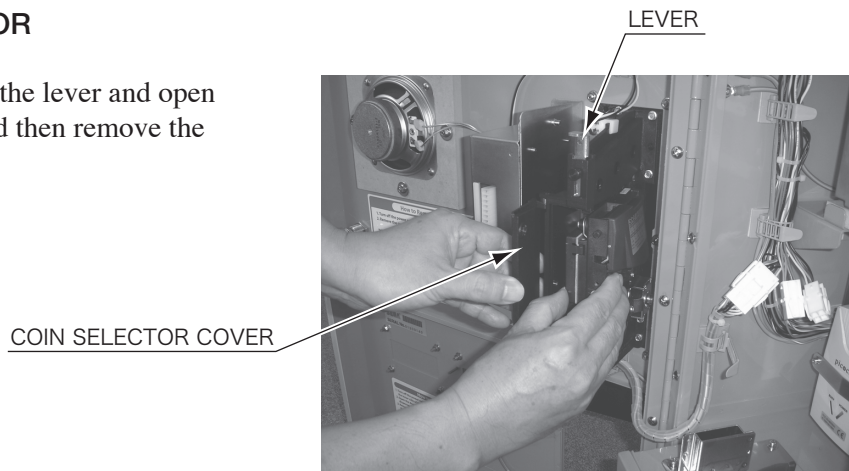

PHOTO 15

REMOVING A JAMMED COIN

When the coin return button fails to refund coins, open the coin chute door and open the selector gate. Once the jammed coin is removed, insert a standard coin to ensure that the selector is working properly.

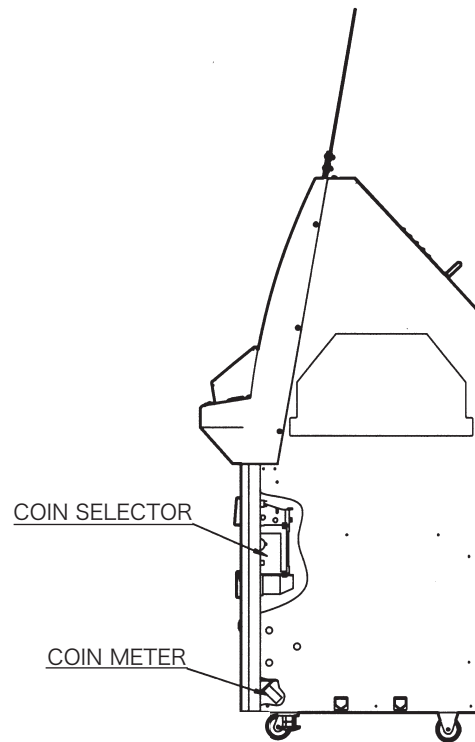

FIG.15a

CLEANING THE COIN SELECTOR



- Remove and clean smears using a soft cloth dipped in water or diluted chemical detergent and then wrung dry.
- Never apply machine oil, etc. to the coin selector.
- After cleaning the coin selector, properly insert a standard coin to ensure that the selector functions correctly.

The coin selector should be cleaned once every 3 months. When cleaning, follow the procedures below:

- ① Turn off the main AC unit power switch and open the coin chute door.
- ② Open the gate and remove dust using a soft brush (made of wool, etc.).
- ③ Remove and clean smears by using a soft cloth dipped in water or diluted chemical detergent and then wrung dry.
- ④ Remove the cradle. When detaching the retaining ring (E ring), be extra careful not to bend the rotational axis.
- ⑤ Use a soft cloth to wipe any dirt/debris off the rotational axis and bearings.
- ⑥ After wiping as described in the previous step, use a dry cloth, etc. to dry the coin selector completely.

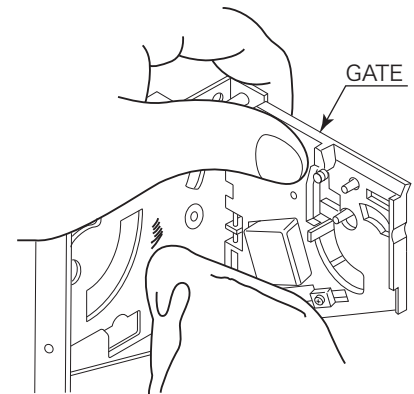

FIG.15b

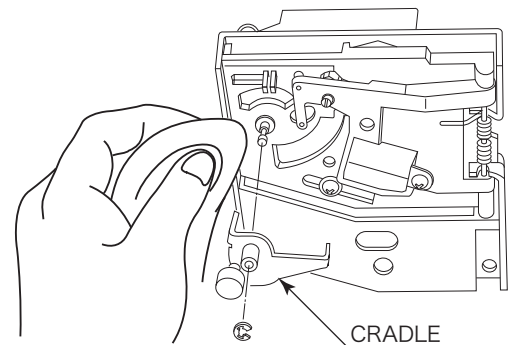

FIG.15c

15

COIN INSERTION TEST

Once every month, when performing the Coin Switch Test, check the following points:

- Does the Coin Meter count properly?
- Do coins drop into the Cashbox correctly?
- Are coins rejected when inserted while holding down the Reject Button ?

BILL ACCEPTOR

- ① When collecting money, performing a maintenance check or cleaning the unit first unlock it with the supplied key.
- ② See the attached sticker or enclosed Bill Acceptor manual (Bill Acceptor "Installation Guide") for further details on handling, checking and altering the settings for the bill acceptor.

16. MONITOR

16-1 CAUTIONS/WARNINGS REGARDING SAFETY FOR HANDLING THE MONITOR

Before handling the monitor, be sure to read the following points and comply with the caution/warning instructions given below. Note the caution/warning symbols and letters used in the instructions.



WARNING

Indicates that handling the monitors improperly by disregarding this warning may potentially cause a hazardous situation, which could result in death or serious injury.



CAUTION

Indicates that handling the monitors improperly by disregarding this warning may potentially cause a hazardous situation, which could result in death or serious injury.



Indicates the instruction to disconnect or unplug a power connector.



Indicates that access to a specific part of the equipment is forbidden.



WARNING

- When performing such work as installing and removing the monitor, inserting and disconnecting the external connectors to and from the monitor interior and the monitor itself, be sure to disconnect the power connector (plug) beforehand. Proceeding without doing so can cause electric shock or malfunctioning.
- Use of the monitor by converting it without permission is not allowed. SEGA shall not be liable for any malfunctioning and accidents caused by such a conversion.



WARNING

- **Primary side and Secondary side**
The monitor's circuit, which is divided into the Primary side and Secondary side, is electrically isolated. Do not touch the Primary side, or touch both the primary side and the secondary side simultaneously. Failing to observe this instruction can cause electric shock, leading to serious danger. When making monitor adjustments, use a non-conductive driver and make them without touching any part other than the Adjustment V. R. and knob. Also, be sure not to cause a short circuit to the Primary side and Secondary side. If a short circuit occurs, it can cause electric shock or malfunctioning, which poses a serious risk of danger.
- **High Voltage**
Some of the parts inside the monitor are subject to high voltage in excess of 20,000 volts and pose a serious threat. Therefore, do not touch the monitor interior. Should soldering & paper wastes, etc. be mixed in the monitor interior, turn the power off so as not to cause malfunctioning or a fire hazard.

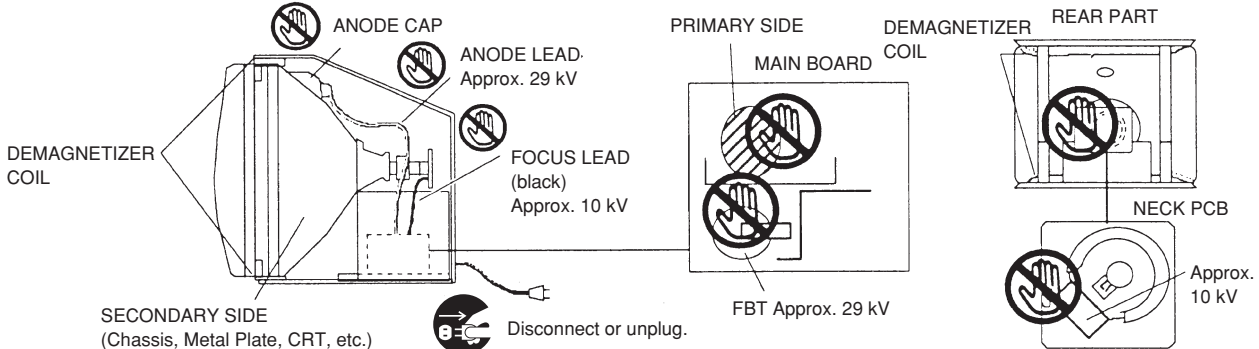
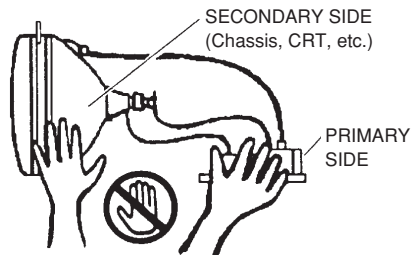

- **Connecting the CRT and PCB**
When combining the CRT and PCB, use the specified part No. to maintain the factory settings. The anode of the CRT itself will charge as time elapses, generating high voltage that is very dangerous. The monitor should be used with the Chassis, CRT, and PCB assembled. When repair, etc. is required at the time of malfunctioning, be sure to send it in an assembled state. If it is disassembled, the charged high voltage can be released, causing a very hazardous situation. Therefore, under no circumstances should it be disassembled.



CAUTION

- **Static Electricity**
Touching the CRT surface sometimes causes a slight shock. This is because the CRT surfaces are subject to static and will not adversely affect the human body.
- **Installation and Removal**
Ensure that the Demagnetizer Coil, FBT (Fly-Back Transformer), Anode Lead, and Focus Lead are not positioned close to the sheet metal work's sharp edges, etc. and avoid damaging the insulated portions so as not to cause electric shock and malfunctioning. (For the name of parts, refer to the figures above.)

16-2 CLEANING THE CRT SURFACES AND THE MONITOR COVER



Observe the following points to prevent damage when cleaning accessory surfaces.

- Remove smears using a dry, soft cloth (flannel, etc.). Do not use coarse gauze or other harsh materials.
- For smear removing solvent, alcohol (ethanol) is recommended. When using chemical detergent, be sure to follow the instructions below:
- Soak a soft cloth in a neutral household detergent diluted with water. Wring the cloth well, and then clean down the surface.
- Do not use bleach or detergent that contains abrasive agents.
- Do not use alkaline chemical detergents such as “glass cleaner” available on the market or solvents such as thinner, etc.
- Do not scrape or scratch surfaces using brushes, scouring pads, or other hard cleaning utensils.

Clean the CRT surface and the monitor cover once a week. Apply antistat after cleaning.

- ① Turn off the main AC unit power switch.
- ② Remove the 9 truss screws after removing the POP and detach the front mask half way, then disconnect the 3 connectors inside the control panel.
- ③ The monitor (CRT) will be exposed. Use an untreated soft cloth to wipe off both the CRT surface and the monitor cover.
- ④ After cleaning, spray antistat onto the CRT and the monitor side of the monitor cover.

16

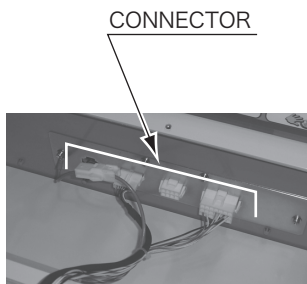

PHOTO16.2

When disconnecting the connector, be careful not to pull the front mask too tightly.

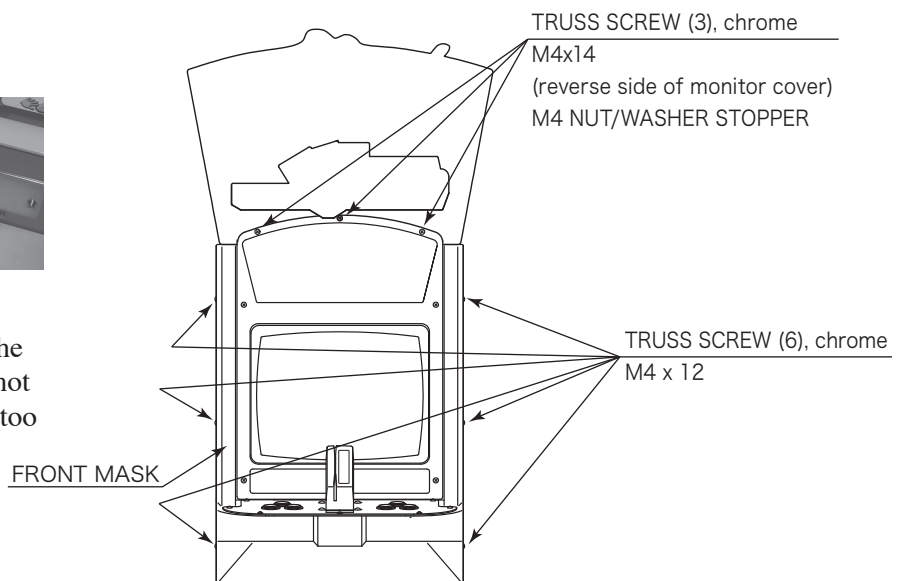

FIG.16.2

16-3 MONITOR ADJUSTMENT



- Monitor adjustments have been made at the time of shipment. Therefore, do not make further adjustments without a justifiable reason. Adjusting the monitor containing high-tension parts is dangerous. Also, an improper adjustment can cause deviated synchronization and image fault, resulting in malfunctioning.
- When making monitor adjustments, use a resin regulating rod. Using bare hands or conductive tools can cause electrocution.
- Be sure to perform appropriate adjustments of the monitor. When operating this machine, do not leave the monitor's flickering or deviation unchecked. Failure to observe this can worsen the players' or the customers' physical conditions.
- Do not touch undesignated places. They can cause electric shock or short circuit.

The monitor regulation board is located on the lower part of the monitor.

DESCRIPTION OF ADJUSTMENT KNOBS

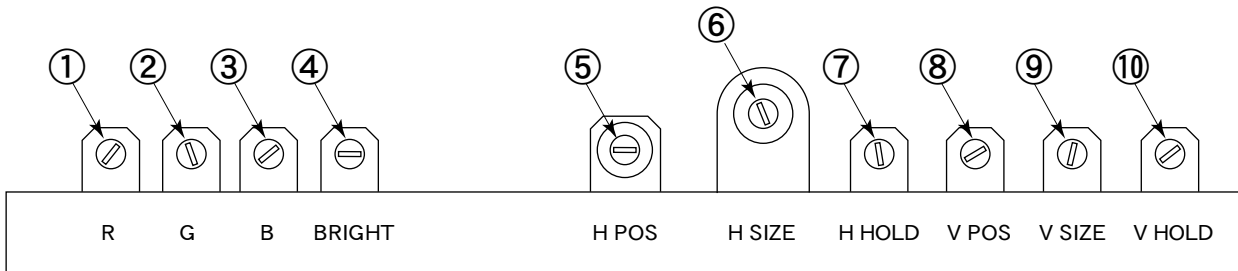
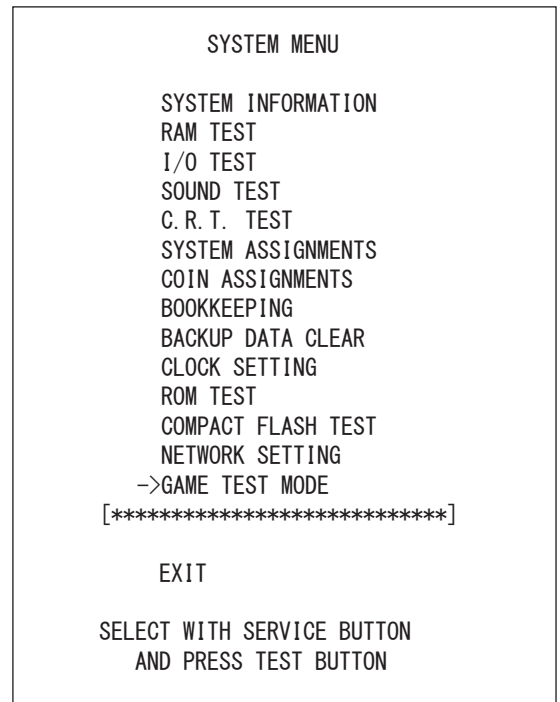

FIG.16.3

- | | | |
|-----------|---|---|
| ① R. GAIN | } | Adjusts each VR to get a suitable contrast and white balance. |
| ② G. GAIN | | |
| ③ B. GAIN | | |
| ④ BRIGHT | : | Adjusts screen brightness. |
| ⑤ H POSI | : | Adjusts horizontal positioning of screen. |
| ⑥ H SIZE | : | Adjusts horizontal screen dimension. |
| ⑦ H HOLD | : | Adjusts horizontal scrolling of screen. |
| ⑧ V POSI | : | Adjusts vertical positioning of screen. |
| ⑨ V SIZE | : | Adjusts vertical screen dimension. |
| ⑩ V HOLD | : | Adjusts vertical scrolling of screen. |

HOW TO CONFIRM ADJUSTMENTS

- ① Enter TEST MODE and select GAME TEST MODE by positioning the cursor and pressing the TEST Button.



- ② Position the cursor with CRT TEST and press the TEST Button to display the CRT TEST screen.

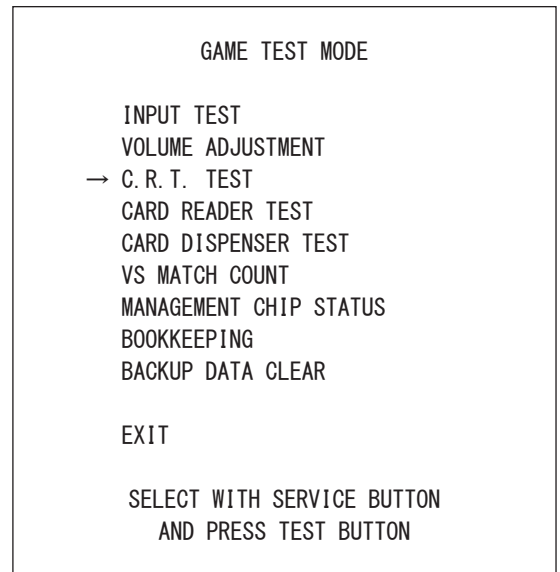

16

The white frame is visible all around the screen.

The 31st color gradation is set to be faintly visible. (The 32nd gradation for each color is black.)

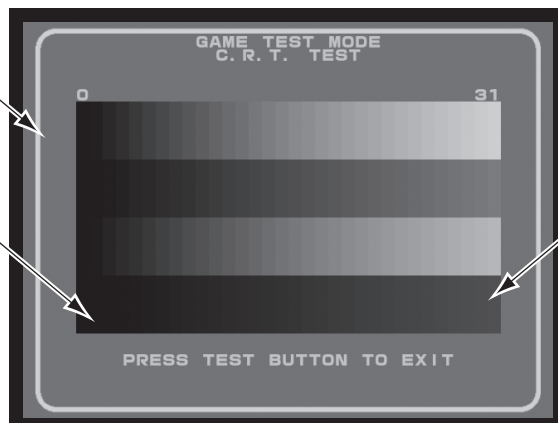

The black portion of the image is not entirely visible around the screen.

The top 2 gradations are set at the same level. (No gradation difference.)

PHOTO16.3

17. PERIODIC INSPECTION

The items listed below require periodic check and maintenance to retain the performance of this machine and to ensure safe business operation.



- Be sure to check once a year to see whether Power Cords are damaged, the plug is securely inserted, dust has accumulated between the Socket Outlet and the Power Plug, etc. Using the product with accumulated dust can cause fire and electric shock.
- Never use a water jet, etc. to clean inside and outside the cabinet. If the machine gets wet for any reason, do not use it until it has completely dried.
- Periodically, around once a year, get in touch with the place of contact herein stated or the Distributor, etc. where the product was purchased from, regarding internal cleaning. Using the product with accumulated dust in the interior can cause a fire or accident. Note that professional interior cleaning will require a fee.

TABLE 17 PERIODIC INSPECTION TABLE

ITEMS	DESCRIPTION	PERIOD	REFERENCE
CABINET	Checking Adjusters/Hold Brackets grounding	Daily before opening hours	3, 6 [1]
MONITOR	Screen Cleaning	Biweekly	16
	Check adjustments.	Monthly	16
GAME BOARD	Check settings.	Monthly	10, 19
CARD READER	Head Cleaning	Monthly	13
SPEAKERS/SOUND	Sound Test, Check sound volume adjustment.	Monthly	11
COIN SELECTOR	Coin Insertion Test	Monthly	15
	Cleaning	Tri-monthly	15
POWER SUPPLY PLUG	Inspection and Cleaning	Annually	See above.
INTERIOR	Cleaning	Annually	See above.
CABINET SURFACES	Cleaning	As necessary	See below.

CLEANING THE CABINET SURFACES

When the cabinet surfaces become dirty, remove stains with a soft cloth soaked in water or diluted (with water) chemical detergent and then wrung dry. To avoid damaging the finish, do not use such solvents as thinner, benzene, etc. (other than ethyl alcohol) or abrasives (bleaching agent and chemical dust-cloth).

Some general-purpose household, kitchen, and furniture cleaning products may contain strong solvents that degrade plastic components, coatings, and print. Before using any cleaning product, read the product's cautionary notes carefully and test the product first on a small area that is not highly visible.

18. TROUBLESHOOTING



WARNING

- In order to prevent electric shock and short circuit, be sure to turn power off before working on the machine.
- Be careful not to damage wiring. Damaged wiring may cause electric shock or short circuit.
- After fixing the problems regarding the Circuit Protector, reinstate the Circuit Protector. Depending on the cause of the problem, using the Circuit Protector without addressing the malfunction can generate heat and can present a fire hazard.
- In the event that a problem cannot be resolved by employing the procedures listed in this manual, be sure to request service from the office shown on this manual or the dealer from whom the product was originally purchased. Attempts to employ procedures other than those specified in this manual can cause electrical shock, shorting, or fire.



IMPORTANT

If a problem occurs, first check to make sure that the wiring connectors are properly connected.

TABLE 18a TROUBLESHOOTING TABLE

PROBLEMS	CAUSE	COUNTERMEASURES
Turning on the power switch fails to power on the machine.	The power is not ON.	Firmly insert the power plug into the outlet.
	Either the main switch or the power switch is turned off.	Turn on both the main switch and the power switch.
	Incorrect power source/voltage.	Make sure that the power supply/voltage is correct.
	The Circuit Protector malfunctions due to a power surge.	After eliminating the cause of the power surge, restore the Circuit Protector of the AC Unit. (See next page.)
Sound is not emitted.	Sound volume adjustment is not correct.	<ul style="list-style-type: none"> • Adjust the sound volume in the Test Mode. • Adjust the sound volume with “VR1” on SystemSP board. (See Section 10.)
	Sound-related circuit malfunction.	Perform SOUND TEST.
Cards are not dispensed.	Cards are empty.	Refill cards.
	Card jam.	Remove the jammed card(s).
	The connector is not connected properly.	Ensure proper connection.
	Card dispenser malfunction.	Exchange the card dispenser.

TABLE 18b TROUBLESHOOTING TABLE

PROBLEMS	CAUSE	COUNTERMEASURES
Cannot scan (read) cards.	Card reader card slot is dirty.	Use the attached cleaning card to clean the card slot.
	The connector is not connected properly.	Ensure proper connection.
	Card reader malfunction.	Exchange the card reader.
Cannot enter TEST MODE.	Switch malfunction.	Exchange the switch.
	Game Board abnormality.	Exchange the Game Board.
	The operation used to change to TEST MODE is incorrect.	Ensure correct operation.
Monitor display is abnormal.	Game Board and monitor connection failure.	Ensure proper connection (of connector).
	Monitor malfunction.	Exchange the monitor.
	Game Board malfunction.	Exchange the Game Board.
There is no response from control panel buttons.	Button failure.	Exchange the button(s).
	The connector is not connected properly.	Ensure proper connection.
	Not set to game mode.	Change setting to game mode.

CIRCUIT PROTECTOR

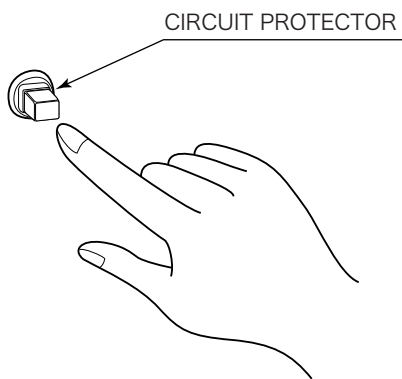

FIG.18

The Circuit Protector uses a bimetal to break the circuit. Due to the heat, the machine cannot be restarted until it cools. Wait at least 1 minute before restarting. (Press the button in.)

19. GAME BOARD



- In order to prevent electric shock and short circuit, be sure to turn power off before working on the machine.
- Be careful not to damage wiring. Damaged wiring may cause electric shock or short circuit.
- Do not expose the Game Board, etc. for any reason. Doing so may cause electric shock or malfunctioning.



- There is no need to handle the Game Board for this machine since all setting changes are done in TEST MODE. Failure to use the Game Board or any other IC board as shipped can cause electric shock or malfunctioning.
- The chip components on IC boards can be damaged by electrostatic discharge from the human body. Before handling an IC board, always neutralize any static charge in the body by touching a grounded metal surface.

19-1 REMOVING THE GAME BOARD

This produce uses the SystemSP board. When exchanging or repairing it follow the steps below to first remove the ASSY MAIN board from the cabinet and then the SystemSP board.

- ① Turn the AC Unit's main switch OFF and open the back door.
- ② Disconnect all of the connectors to the ASSY MAIN board and undo the cord clamps.

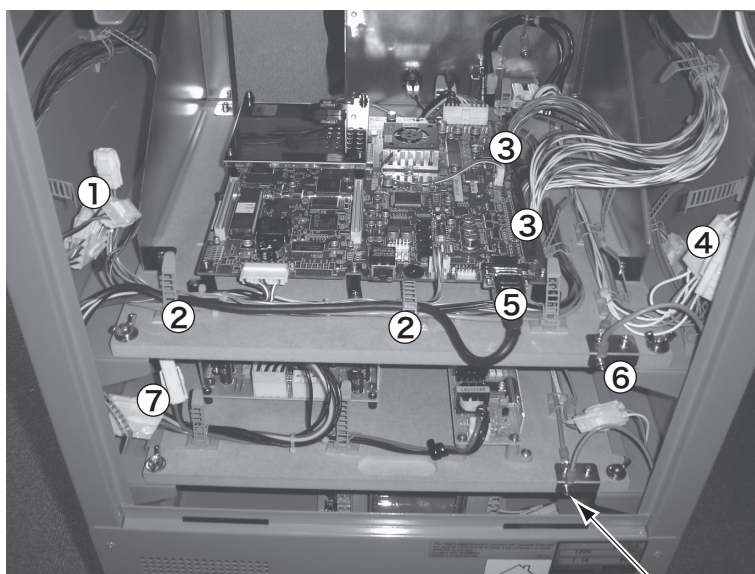

- ① 3 connectors
- ② 1 cord clamp
- ③ 2 connectors
- ④ 2 connectors
- ⑤ D-SUB connector*
- ⑥ 1 earth terminal
- ⑦ 2 connectors and 1 cord clamp

* The screws on the left and right of the D-SUB connector must be loosened before it can be removed.

PHOTO19.1a

SCREW (1)
M4x8

- ③ Remove the two wing bolts and take out the ASSY MAIN board.

WING BOLT (2)
M4x20, flat washer used

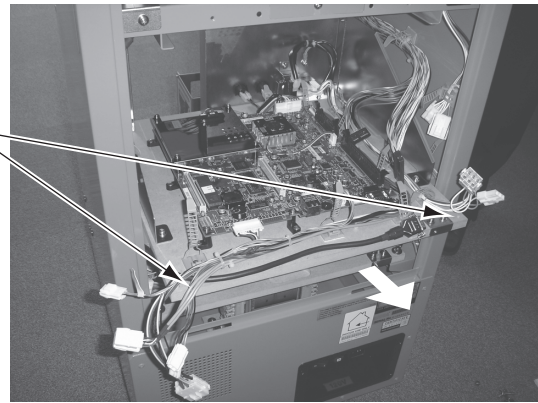

PHOTO19.1b

- ④ Disconnect the four SystemSP board connectors, shown marked with circles in the picture below.

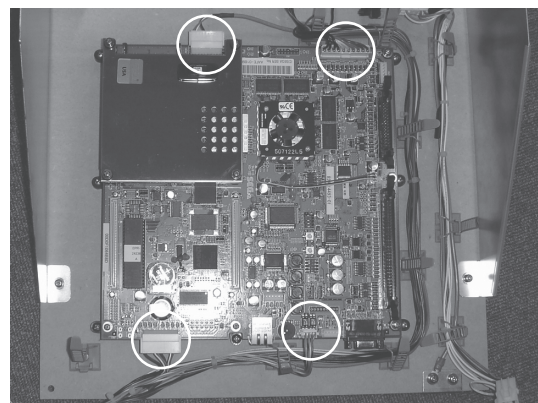

PHOTO19.1c

- ⑤ Remove the 8 screws and take out the SystemSP board base.

TAPPING SCREW (8)
M3.5x16

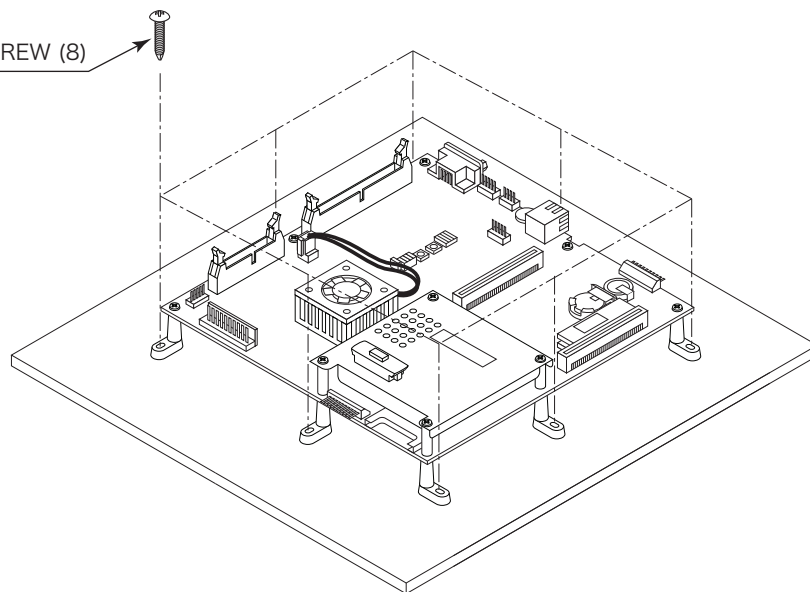

FIG.19.1

19-2 COMPOSITION OF THE GAME BOARD



- The game board is very delicate equipment. Shaking or dropping it may cause an accident or malfunction.
- Static electricity has the potential to damage electronic parts on the IC base board. Before opening the shield case and starting work, touch an earthed metal surface to release any static electricity stored in your body.
- Before exchanging the game board, first read this manual and any other relevant documentation in full.



The DIP SW (Dip switches) and JP (Jumper switches) on the game board must be set as specified below. If any other settings of these switches are used it may lead to an unclear picture or other errors.

GAME BD SP DKG USA (834-14493-01)

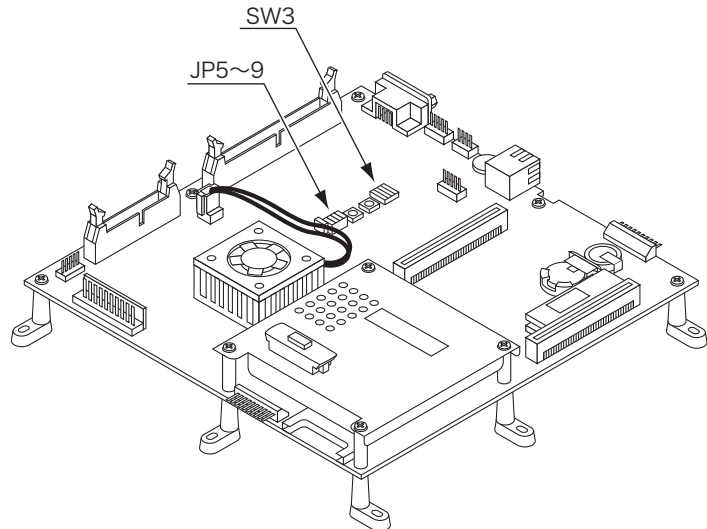

FIG.19.2a

DIP SW Setting

The DIP SW for this product should be set as shown in the following diagram.

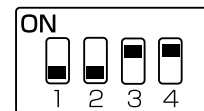

FIG.19.2b

JP (Jumper) Setting

The JP for this product should be set as shown in the following diagram.

	3	2	1
JP 5			
JP 6			
JP 7			
JP 8			
JP 9			

FIG.19.2c

20. DESIGN-RELATED PARTS

For the Warning Display Stickers, refer to Section 1.

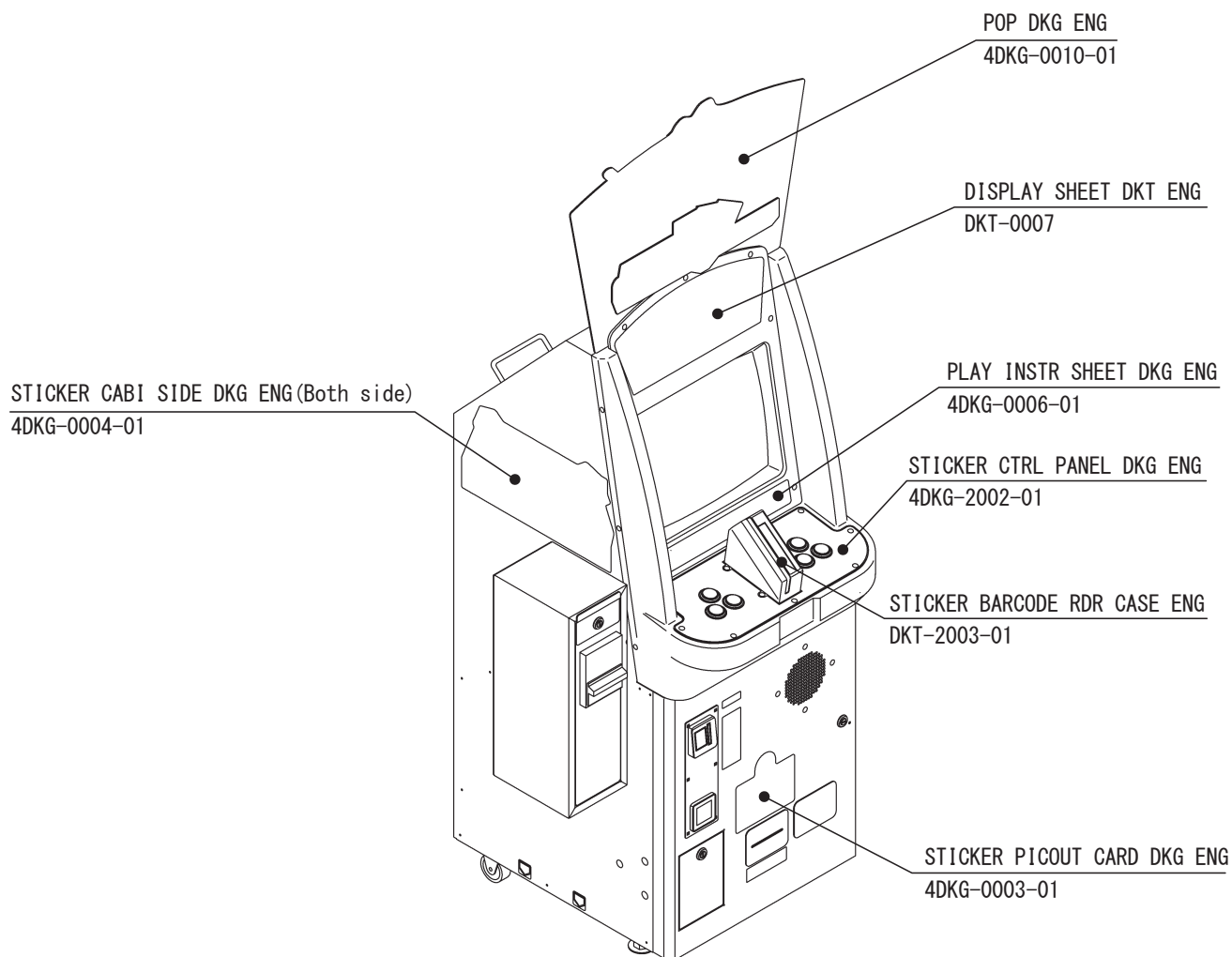
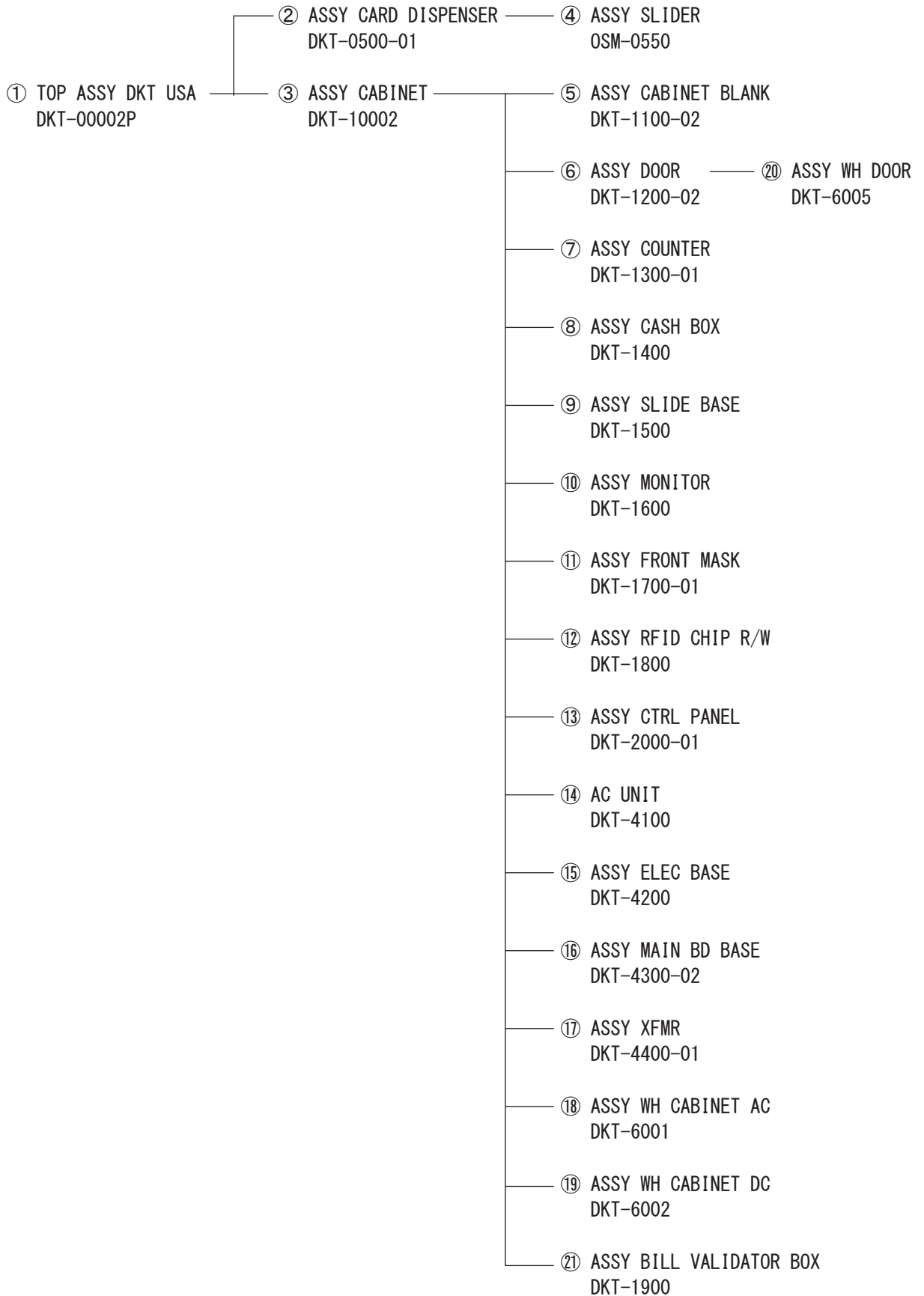
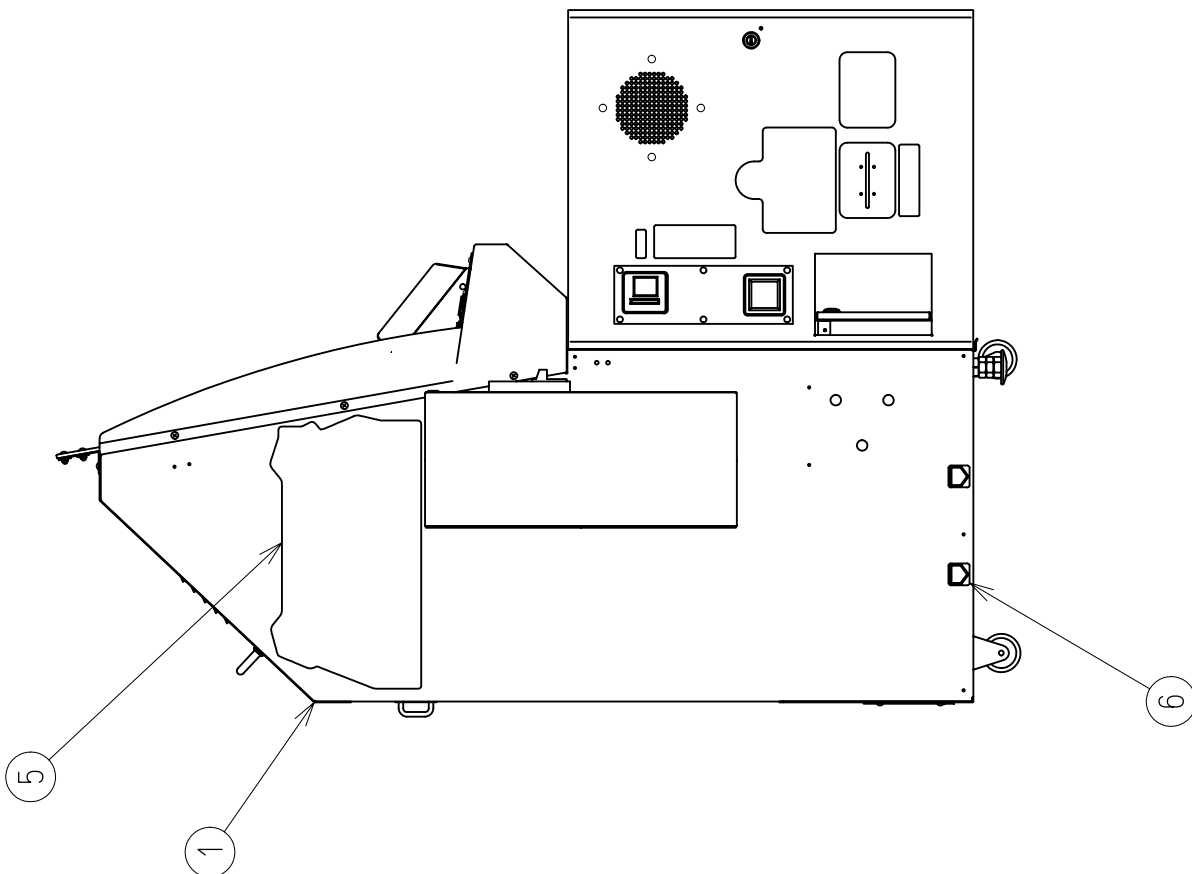
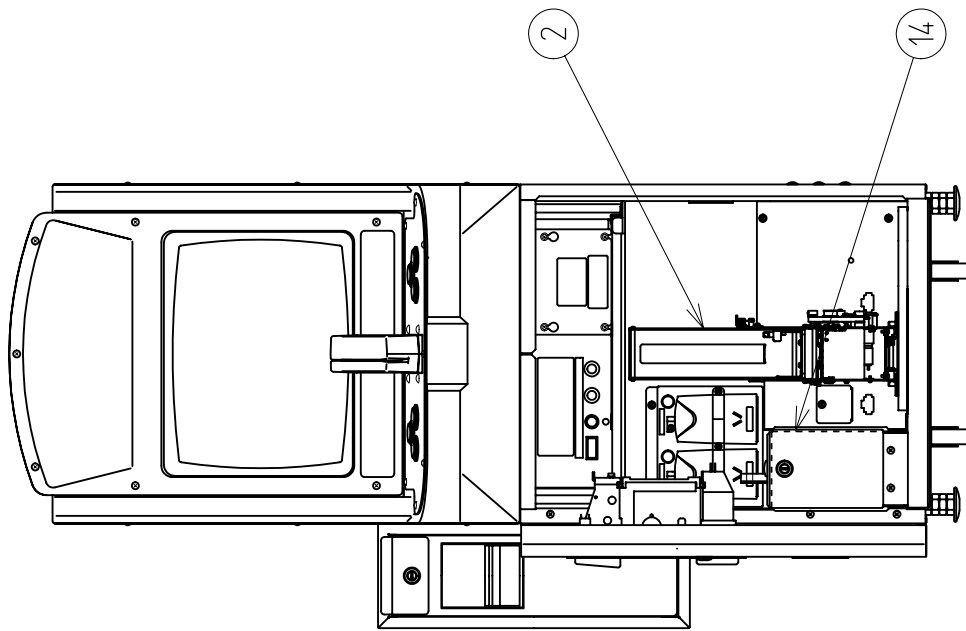
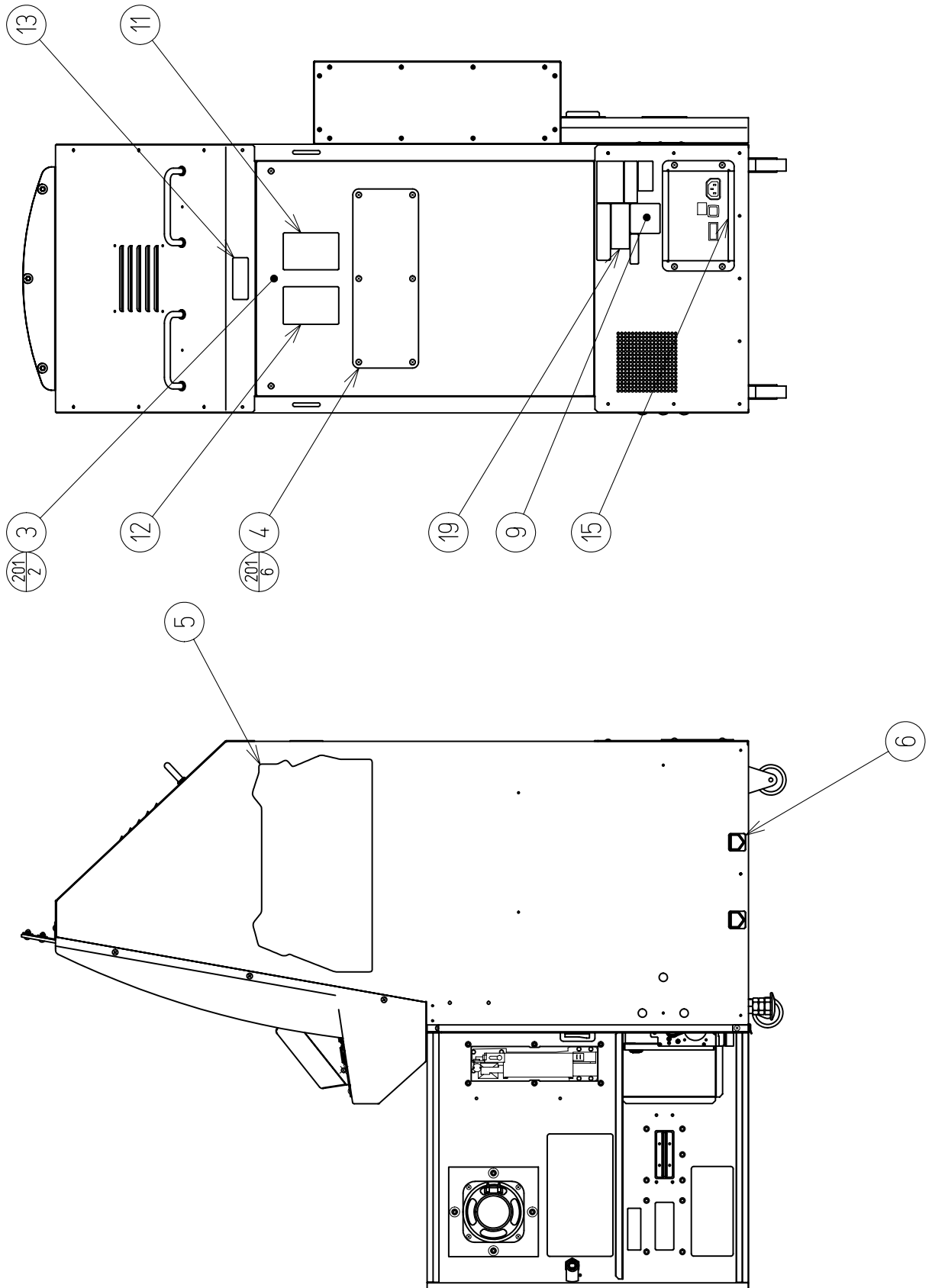

FIG.20

21. PARTS LIST







① TOP ASSY DKT USA (DKT-00002P)

(D-3/3)

ITEM NO.	PART NO.	DESCRIPTION	NOTE
1	DKT-10002	ASSY CABINET	
2	DKT-0500-01	ASSY CARD DISPENSER	
3	DKT-0001	BACK LID	
4	DKT-0002	EXPAND CONN LID	
5	4DKG-0004-01	STICKER CABI SIDE DKG ENG	
6	421-11416	STICKER CAUTION FORK	
9	421-9471	STICKER INDOOR USE ONLY	
11	440-WS0001XEG	STICKER W NOT OPEN DOOR ENG	
12	440-WS0002XEG	STICKER W POWER OFF ENG	
13	440-WS0286-EG	STICKER W DO NOT OPEN ENG	
14	MKG-0015-01	STICKER MANAGEMENT CP R/W ENG	
15	421-6690-01	STICKER 120V	
19	421-11892-01	STICKER UL FOR DKT	
21	421-8479-01	STICKER INSTR SUNLIGHT ENG	
201	008-T00408-0C	TMP PRF SCR TH CRM M4×8	
401	4DKG-0010-01	POP DKG ENG	
402	DKT-0004	POP SUPPORT	
403	601-6604-70	CARTON BOX 70	
404	MKG-0011-01	CLEANING CARD FOR CARD RDR ENG	
407	220-5785	KEY MASTER FOR 220-5784	
408	540-0006-01	WRENCH M4 TMP SCR	(OR)
	540-0069	DRIVER FOR TAMP PRF SCR M4	(OR)
409	000-T00414-0C	M SCR TH CRM M4×14	
410	600-7326	AC CABLE CONNECT TYPE USA 15A	
411	420-6805-02	OWNERS MANUAL DKG ENG UL	
412	DKT-0009	CABINET HOLD BASE	
413	DKT-0010	CABINET HOLD BRKT FR	
414	DKT-0011	CABINET HOLD BRKT RR UPPER	
415	DKT-0012	CABINET HOLD BRKT RR LOWER	
416	FAS-300048	HEX BLT W/FS BLK M5×8	
417	030-000616-SB	HEX BLT W/S BLK M6×16	
418	068-652016-0B	FLT WSHR BLK 6.5-20×16	

② ASSY CARD DISPENSER (DKT-0500-01)

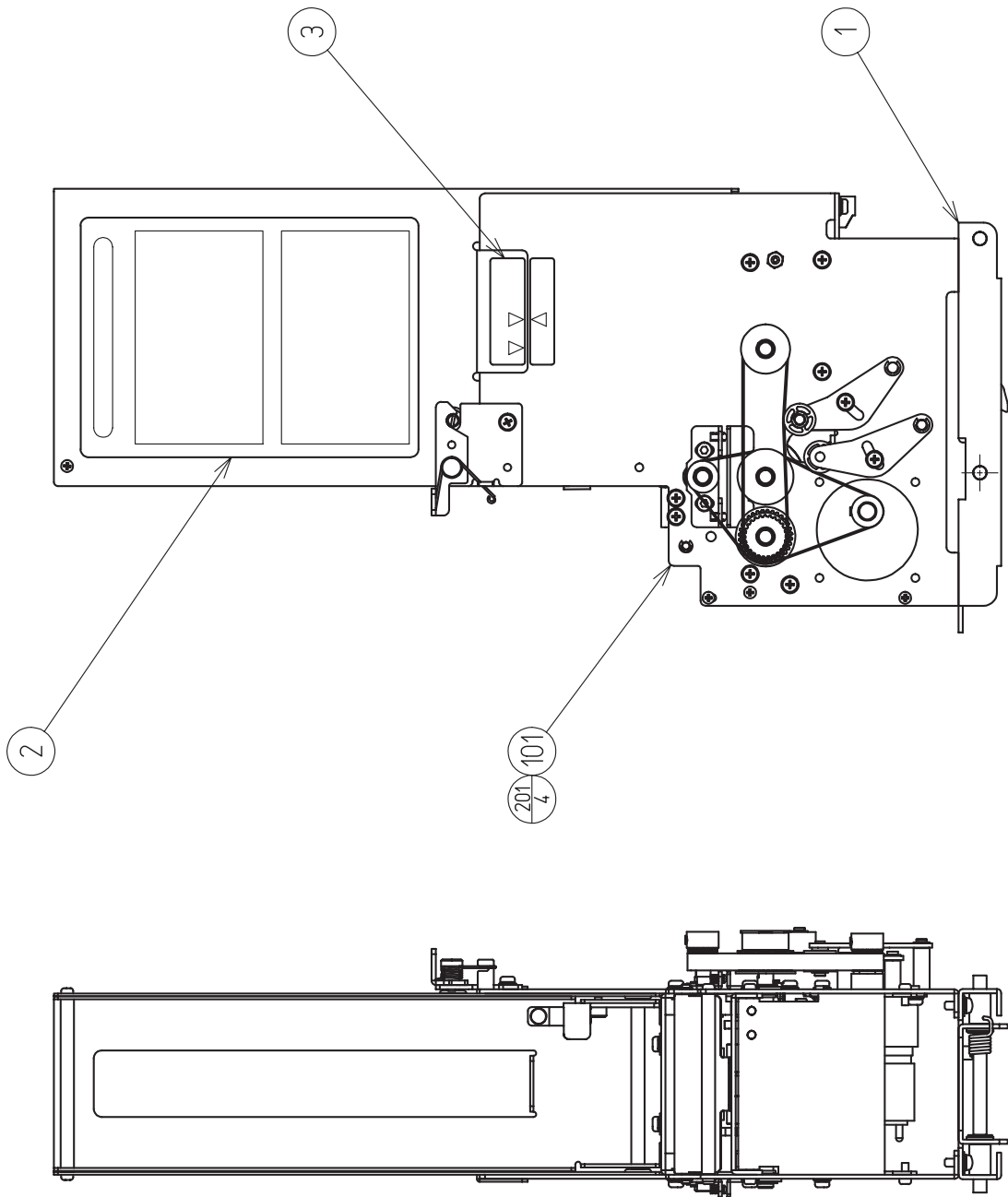

ITEM NO.	PART NO.	DESCRIPTION	NOTE
1	OSM-0550	ASSY SLIDER	
2	MKG-0501-01	STICKER HOW TO RMV STOCKER ENG	
3	MKG-0502	STICKER STOCKER POSITION	
101	610-0668-02	CARD DISPENSER CD-1300 ENG SC	
201	000-P00308-W	M SCR PH W/FS M3×8	
301	DKT-60026	WH CARD DISPENSER	

③ ASSY CABINET (DKT-10002)

(D-1/3)

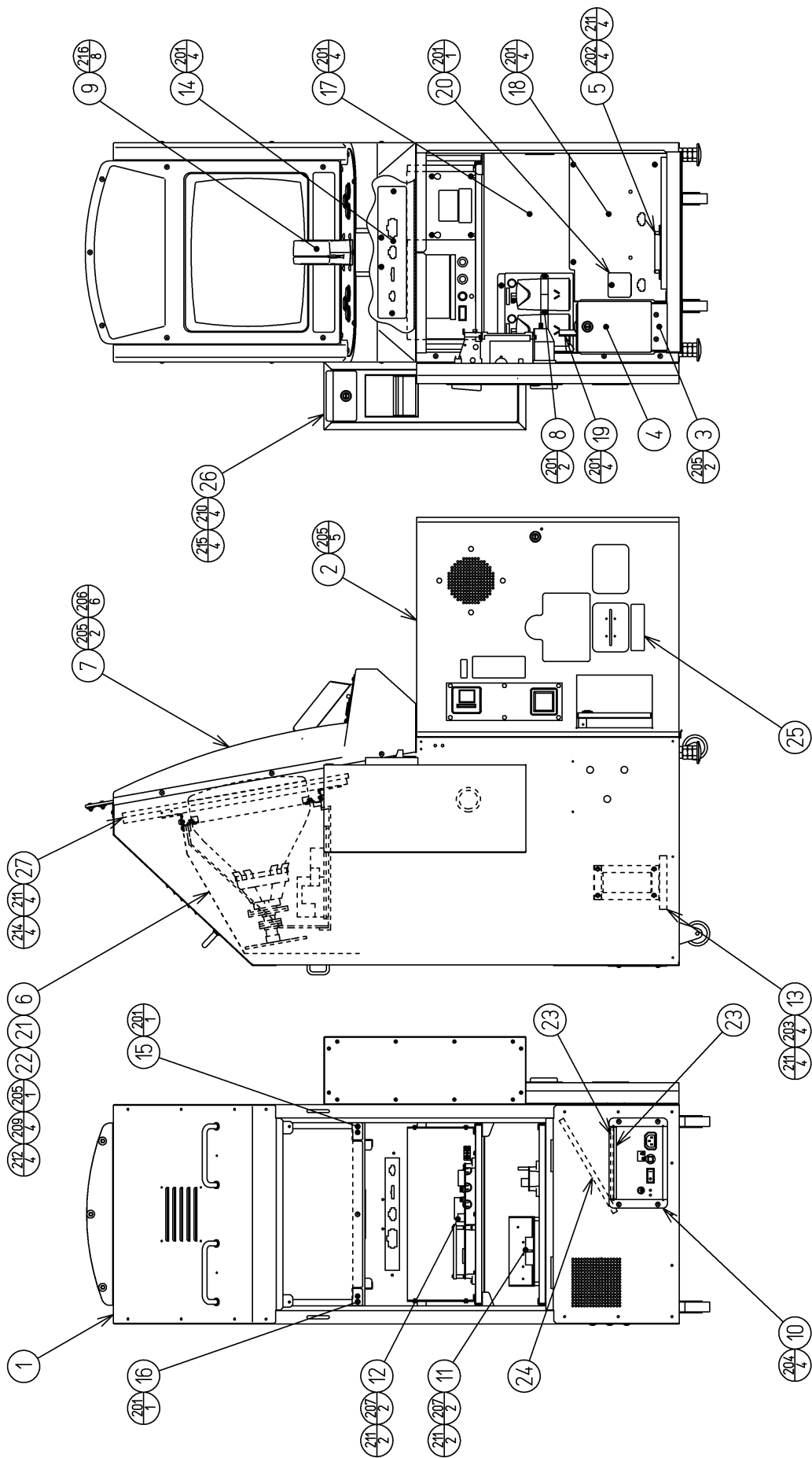

③ ASSY CABINET (DKT-10002)

(D-2/3)

ITEM NO.	PART NO.	DESCRIPTION	NOTE
1	DKT-1100-02	ASSY CABINET BLANK	
2	DKT-1200-02	ASSY DOOR	
3	DKT-1300-01	ASSY COUNTER	
4	DKT-1400	ASSY CASH BOX	
5	DKT-1500	ASSY SLIDE BASE	
6	DKT-1600	ASSY MONITOR	
7	DKT-1700-01	ASSY FRONT MASK	
8	DKT-1800	ASSY RFID CHIP R/W	
9	DKT-2000-01	ASSY CTRL PANEL	
10	DKT-4100	AC UNIT	
11	DKT-4200	ASSY ELEC BASE	
12	DKT-4300-02	ASSY MAIN BD BASE	
13	DKT-4400-01	ASSY XMFR	
14	OSM-1001	PLATE CONN CTRL PANEL	
15	OSM-1002	PLATE CONN MONITOR AC	
16	OSM-1003	PLATE CONN MONITOR RGB	
17	DKT-1001	PARTITION UPPER	
18	DKT-1002	PARTITION LOWER	
19	DKT-1003	COIN CHUTE SHORT	
20	DKT-1004	UK COUNTER LID	
21	MKG-1006	BUSHING EXP	
22	MKG-1007	SPACER EXP	
23	MKG-1014	SPONGE WATER PROOF 147	
24	MKG-1015	SPONGE WATER PROOF 220	
25	440-CS0290-EG	STICKER C CARD PICOUT ENG	
26	DKT-1900	ASSY BILL VALIDATOR BOX	
27	MKG-1009	MONITOR PROTECTOR	
101	280-5009-01	CORD CLAMP 21	
102	280-5277	CORD CLAMP 18	
103	280-5292	CORD CLAMP PUSH TYPE	
104	280-5275-SR10	CORD CLAMP SR10	
105	601-6231-B-025	EDGING NEW TYPE	
106	601-6231-B-110	EDGING NEW TYPE	
107	601-6231-D-050	EDGING NEW TYPE	
108	270-5117	FERRITE CORE TDK ZCAT3035-1330	
109	601-0460	PLASTIC TIE BELT 100MM	
110	280-6581-29	BUSHING NB-29	
201	000-P00408-W	M SCR PH W/FS M4×8	
202	000-P00420-W	M SCR PH W/FS M4×20	
203	000-P00425-W	M SCR PH W/FS M4×25	
204	000-T00408-0B	M SCR TH BLK M4×8	
205	000-T00408-0C	M SCR TH CRM M4×8	
206	000-T00412-0C	M SCR TH CRM M4×12	
207	032-000420	WING BLT M4×20	
208	050-F00400	FLG NUT M4	

③ ASSY CABINET (DKT-10002)**(D-3/3)**

ITEM NO.	PART NO.	DESCRIPTION	NOTE
209	050-F00500	FLG NUT M5	
210	050-F00600	FLG NUT M6	
211	068-441616	FLT WSHR 4.4-16×1.6	
212	068-552016	FLT WSHR 5.5-20×1.6	
213	031-000620-0C	CRG BLT CRM M6×20	
214	000-P00435-W	M SCR PH W/FS M4×35	
215	068-652016	FLT WSHR 6.5-20×16	
216	008-T00412-0C	TMP PRF SCR TH CRM M4×12	
301	DKT-6001	ASSY WH CABINET AC	
302	DKT-6002	ASSY WH CABINET DC	
303	MKG-60035-01	WH EARTH CTRL PANEL EXT EXP	
304	DKT-60001	WH DBA BOX EXT	
305	DKT-60009	WH EARTH DBA BOX	

④ ASSY SLIDER (OSM-0550)

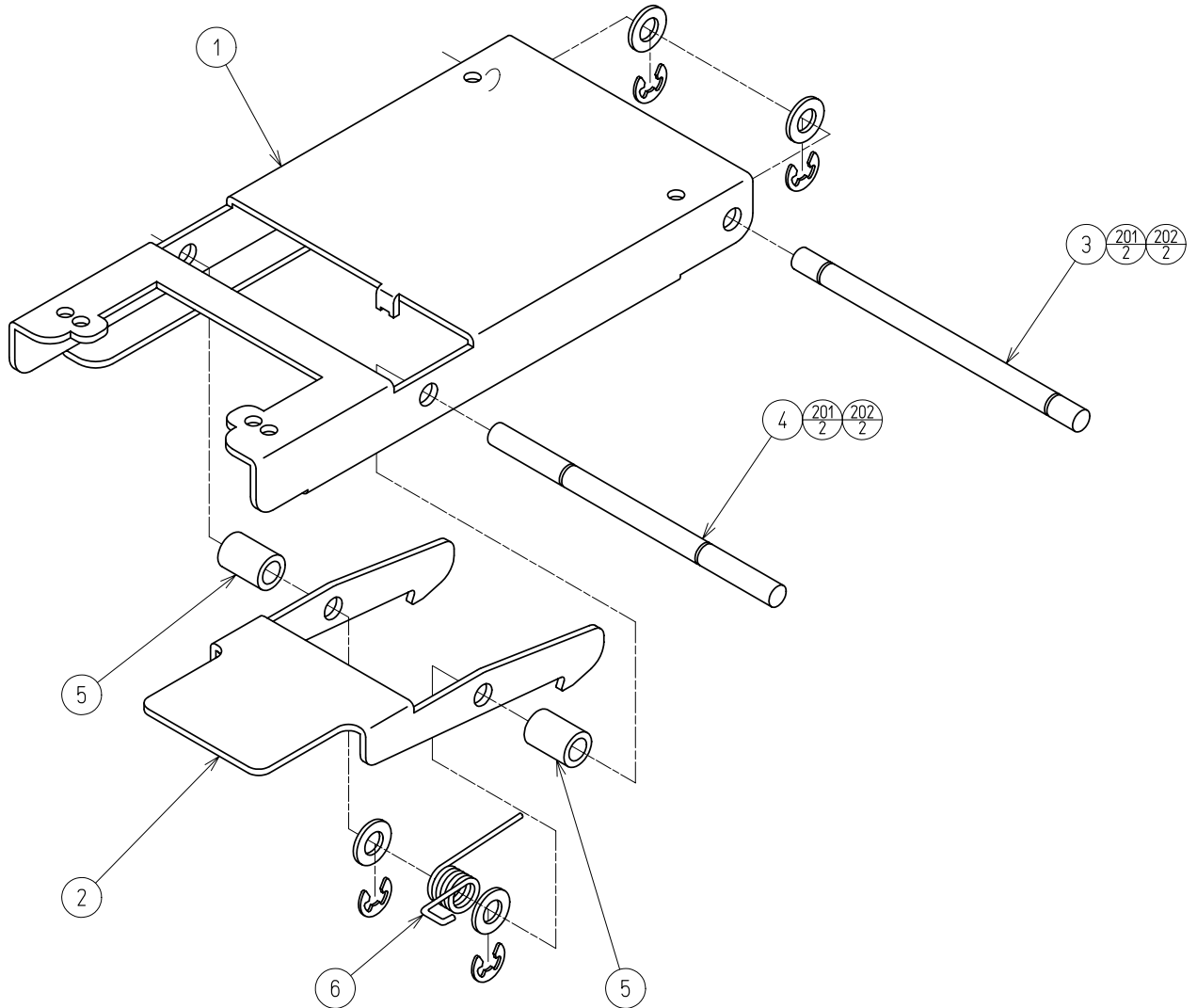

ITEM NO.	PART NO.	DESCRIPTION	NOTE
1	OSM-0551	CD BASE	
2	OSM-0552	STOPPER	
3	MKG-0553	SLIDE SHAFT	
4	MKG-0554	STOPPER SHAFT	
5	MKG-0555	SPACER	
6	MKG-0556	TORSION SPRING	
201	060-F00500	FLT WSHR M5	
202	065-E00400	E RING 4MM	

⑤ ASSY CABINET BLANK (DKT-1100-02)

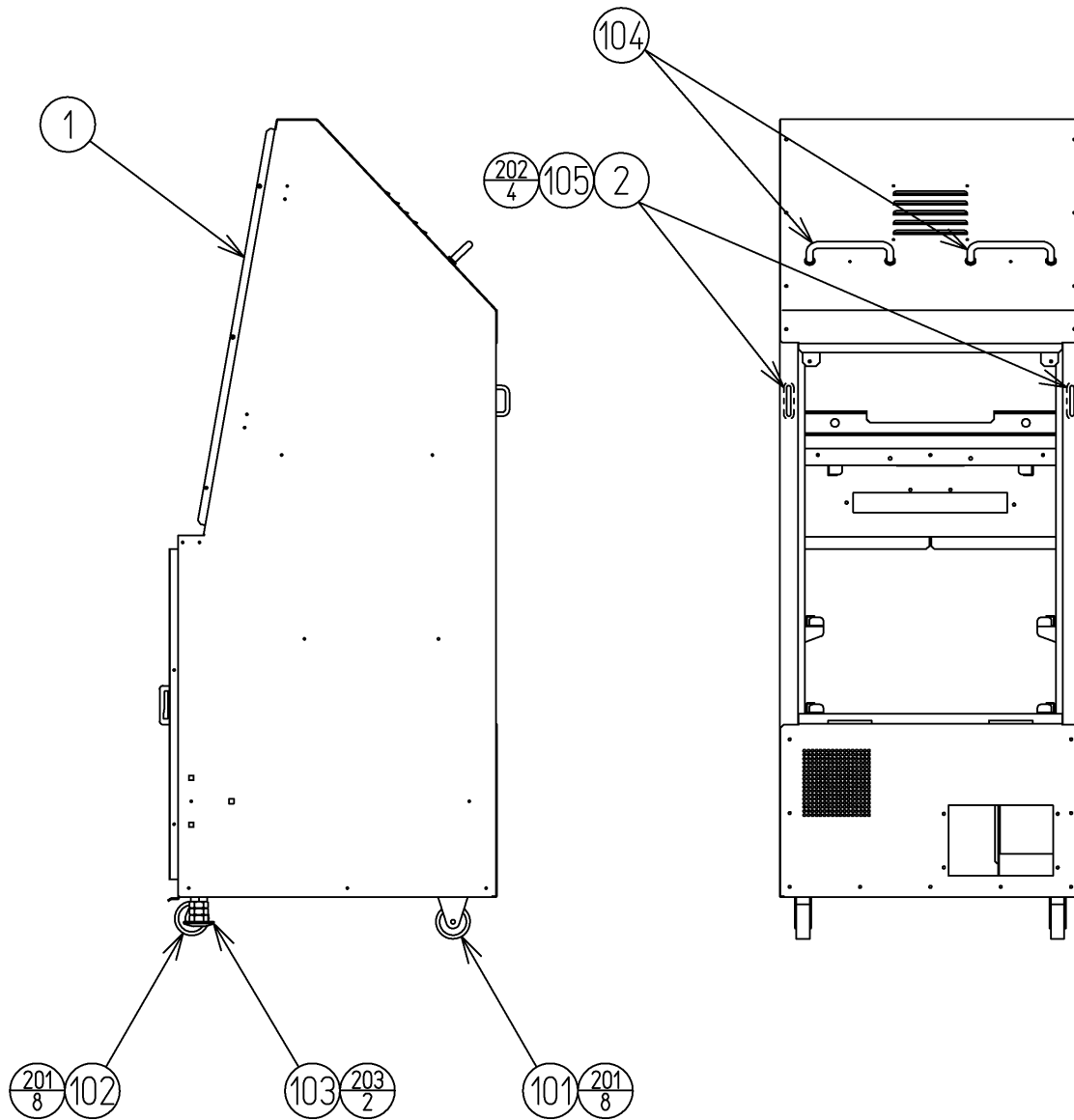

ITEM NO.	PART NO.	DESCRIPTION	NOTE
1	DKT-1101-02	CABINET BLANK	
2	MKG-1103	PLATE CHAIN HOOK	
101	601-10462	CASTER D51H73 FIX	
	601-11634	CASTER D51H73 FIX	
102	601-10905	CASTER D51H66 FREE ST	
	601-11635	CASTER D51H67 FREE ST	
103	601-5699X	LEG ADJUSTER BOLT M16×75	
104	TOE-NMD252	STAINLESS ROUND BAR PULLS	
105	601-11419	SUS ROUND BAR THA-31SUS-2	
201	030-000612-S	HEX BLT W/S M6×12	
202	050-F00400	FLG NUT M4	
203	050-H01600-3	HEX NUT TYPE3 M16	

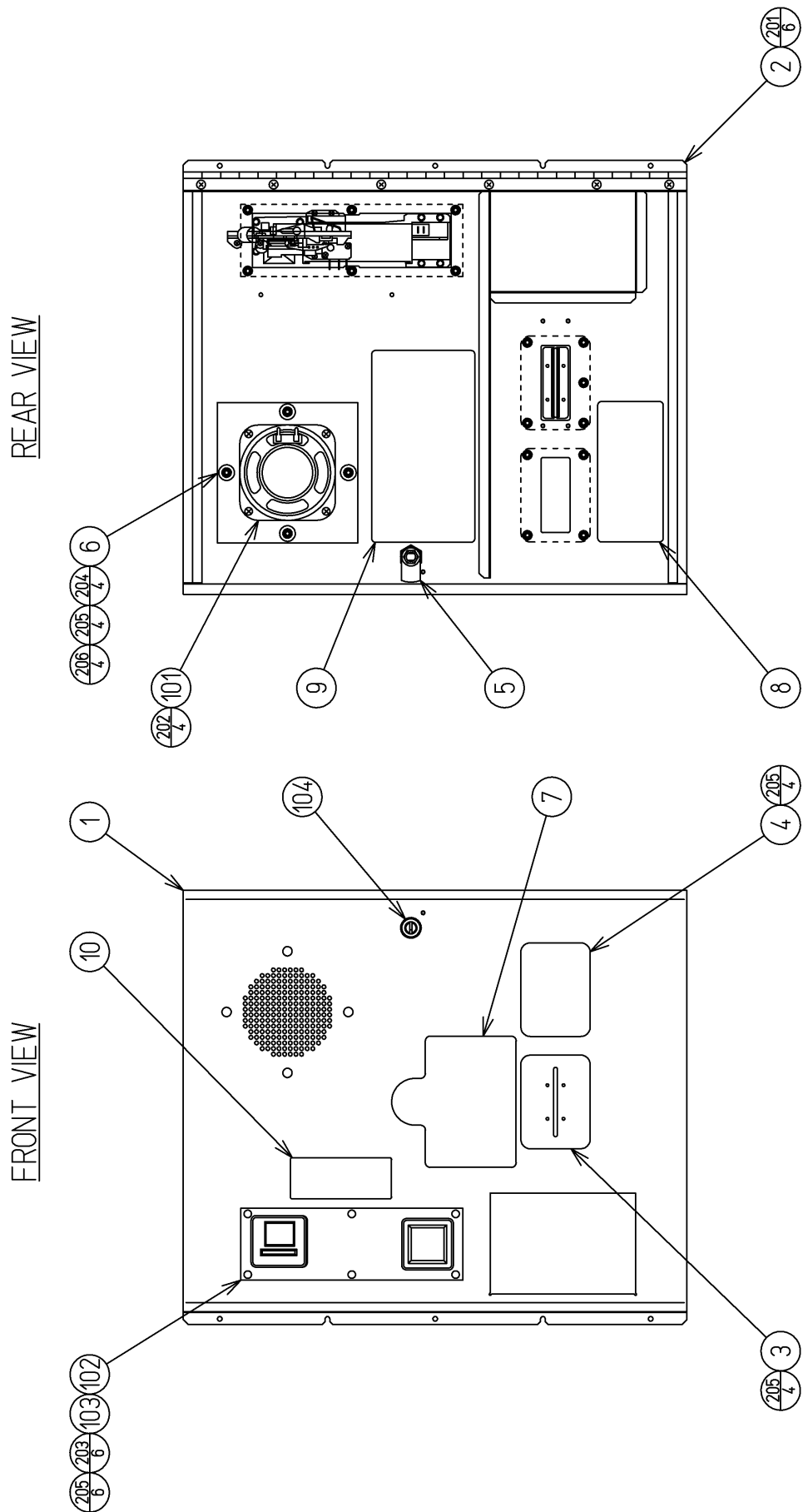

⑥ ASSY DOOR (DKT-1200-02)

(D-2/2)

ITEM NO.	PART NO.	DESCRIPTION	NOTE
1	DKT-1201-01	DOOR	
2	DKT-1202	HINGE	
3	OSM-1203	PICK OUT PLATE	
4	DKT-1203	PICK OUT LID	
5	MKG-1203	TONGUE	
6	MKG-1205	SPEAKER BASE WOODEN	
7	4DKG-0003-01	STICKER PICKOUT CARD DKG ENG	
8	DKT-0005-01	STICKER HOW TO SET CARD ENG	
9	MKG-0012-01X	STICKER HOW TO REMOVE CARD ENG	
10	440-CS0200-EG	STICKER C EPILEPSY MINI ENG	
101	130-5034	SPEAKER 8 OHM 10W	
102	220-5786	C.C BRKT A0710 (LORENZO)	
103	220-5208-05	COIN CHUTE REJR 25 AD-81P	
104	220-5784	CAM LOCK MASTER W/O KEY EXP	
105	280-5277	CORD CLAMP 18	
106	280-5275-SR10	CORD CLAMP SR10	
107	601-0460	PLASTIC TIE BELT 100MM	
108	310-5029-D15	SUMI TUBE F D 15MM	
201	000-T00408-0C	M SCR TH CRM M4×8	
202	011-T03510	TAP SCR TH 3.5×10	
203	031-000410-0C	CRG BLT CRM M4×10	
204	031-000420-0C	CRG BLT CRM M4×20	
205	050-F00400	FLG NUT M4	
206	068-441616	FLT WSHR 4.4-16×1.6	
301	DKT-6005	ASSY WH DOOR	
302	DKT-60002	WH REJECT LAMP	

⑦ ASSY COUNTER (DKT-1300-01)

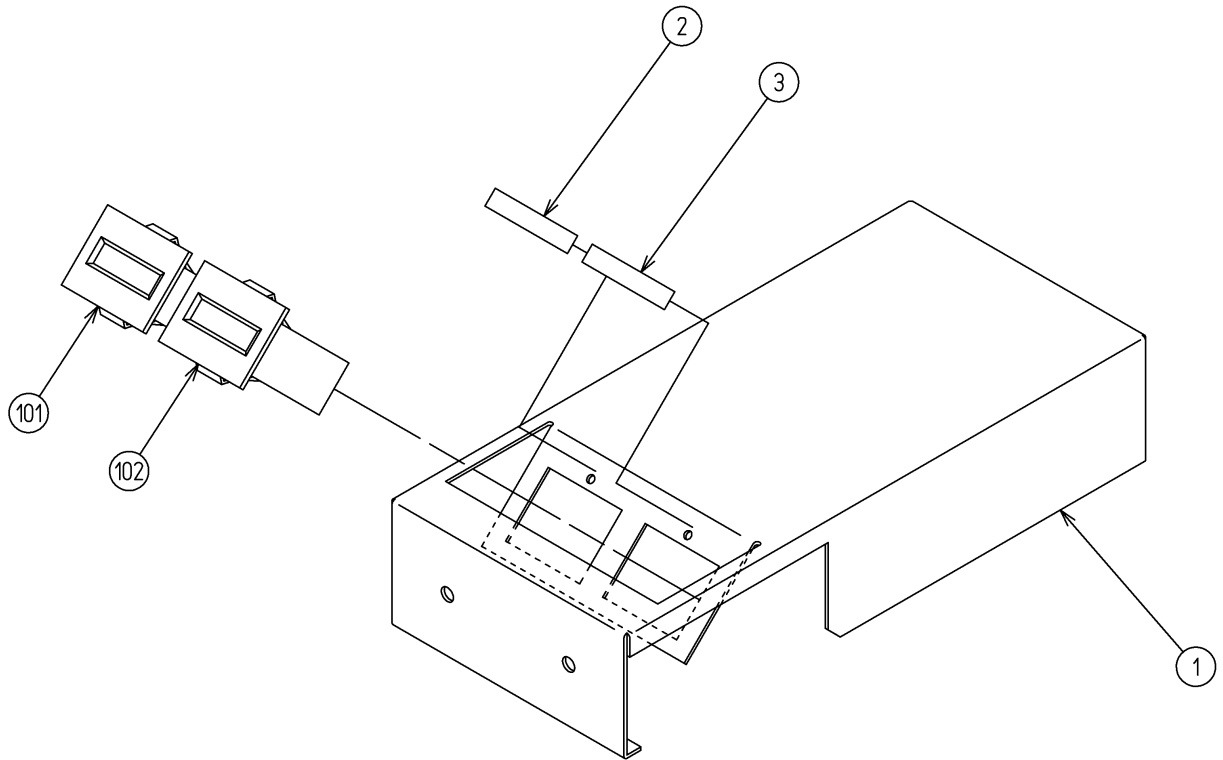

ITEM NO.	PART NO.	DESCRIPTION	NOTE
1	MKS-1301	COUNTER BRKT	
2	421-9168-02	STICKER COIN METER 1	
3	421-9168-03	STICKER COIN METER 2	
101	220-5798-01	MAG CNTR 4P MZ674-DC5V-D41 JC	
102	220-5798-02	MAG CNTR 6P MZ674-DC5V-D42 JC	
103	280-5275-SR10	CORD CLAMP SR10	

⑧ ASSY CASH BOX (DKT-1400)

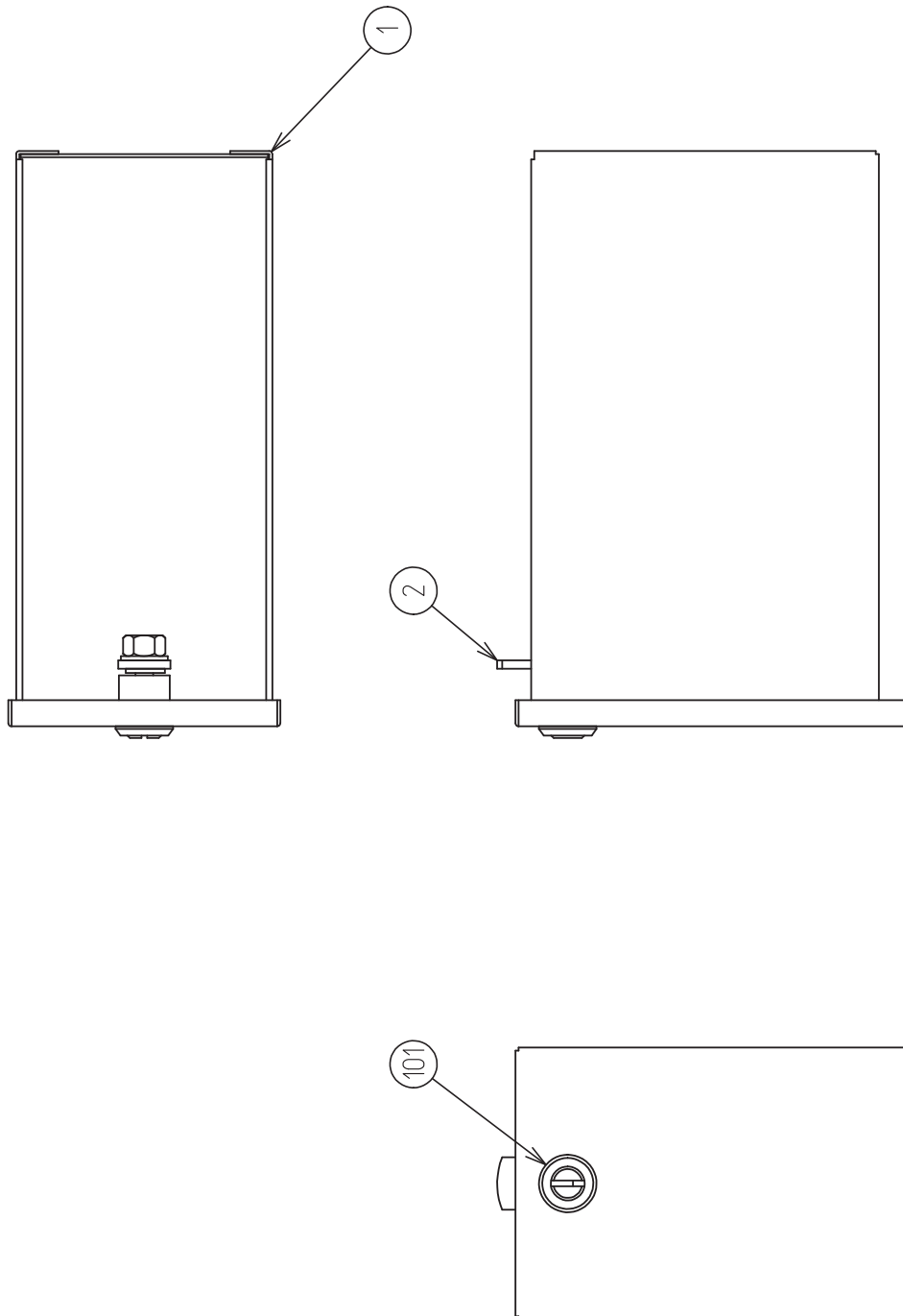

ITEM NO.	PART No.	DESCRIPTION	NOTE
1	DKT-1401	CASH BOX	
2	MKG-1203	TONGUE	
	MKC-1203	TONGUE MKC	
101	220-5574	CAM LOCK W/KEYS	

⑨ ASSY SLIDE BASE (DKT-1500)

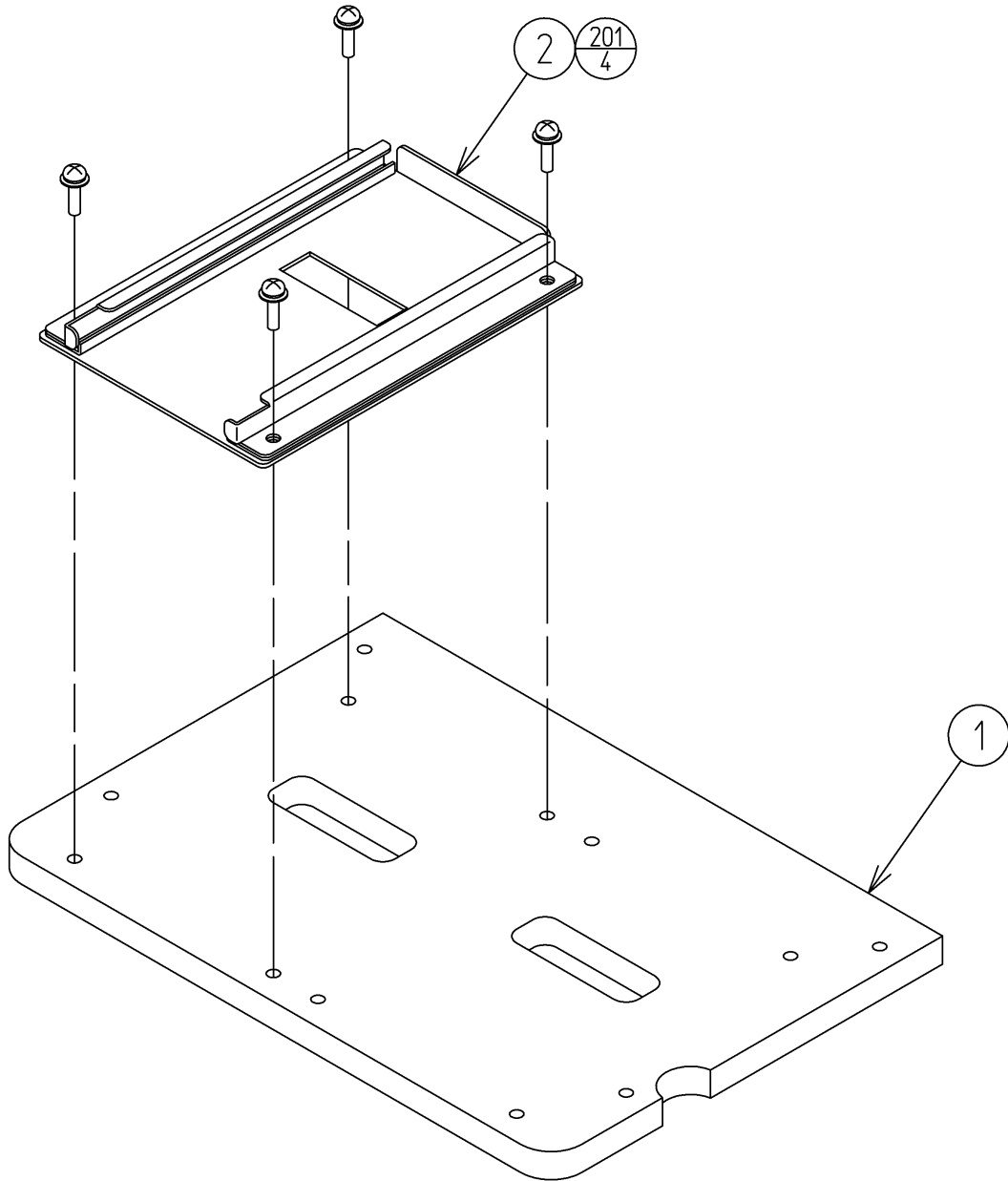

ITEM NO.	PART NO.	DESCRIPTION	NOTE
1	OSM-1501	SLIDE BASE WOODEN	
2	OSM-1502	SLIDE BASE	
201	000-P00416-W	M SCR PH W/FS M4×16	

⑩ ASSY MONITOR (DKT-1600)

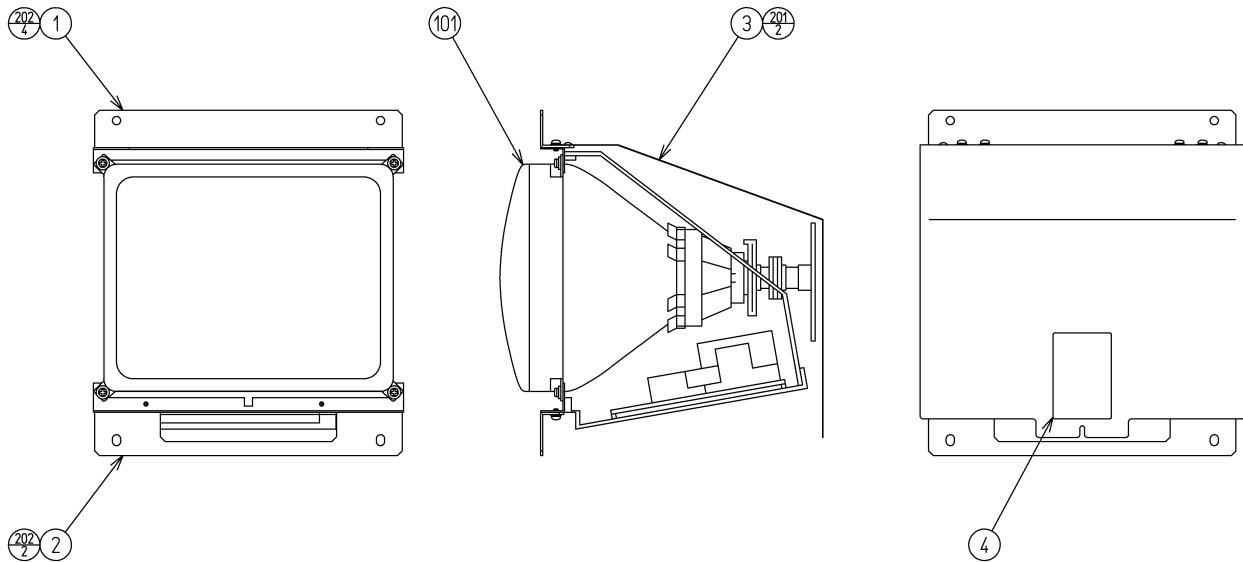

ITEM NO.	PART NO.	DESCRIPTION	NOTE
1	MKG-1601	MONITOR BRKT UPPER	
2	MKG-1602	MONITOR BRKT LOWER	
3	OSM-1601	MONITOR REAR COVER	
4	440-DS0013XEG	STICKER D MONITOR ENG	
101	200-5173-15-07	CLR DSPL 14 15K100 14VC21S HC J	
102	601-0460	PLASTIC TIE BELT 100MM	
103	280-5275-SR10	CORD CLAMP SR10	
201	000-T00408-0C	M SCR TH CRM M4×8	
202	000-P00508-W	M SCR PH W/FS M5×8	

⑪ ASSY FRONT MASK (DKT-1700-01)

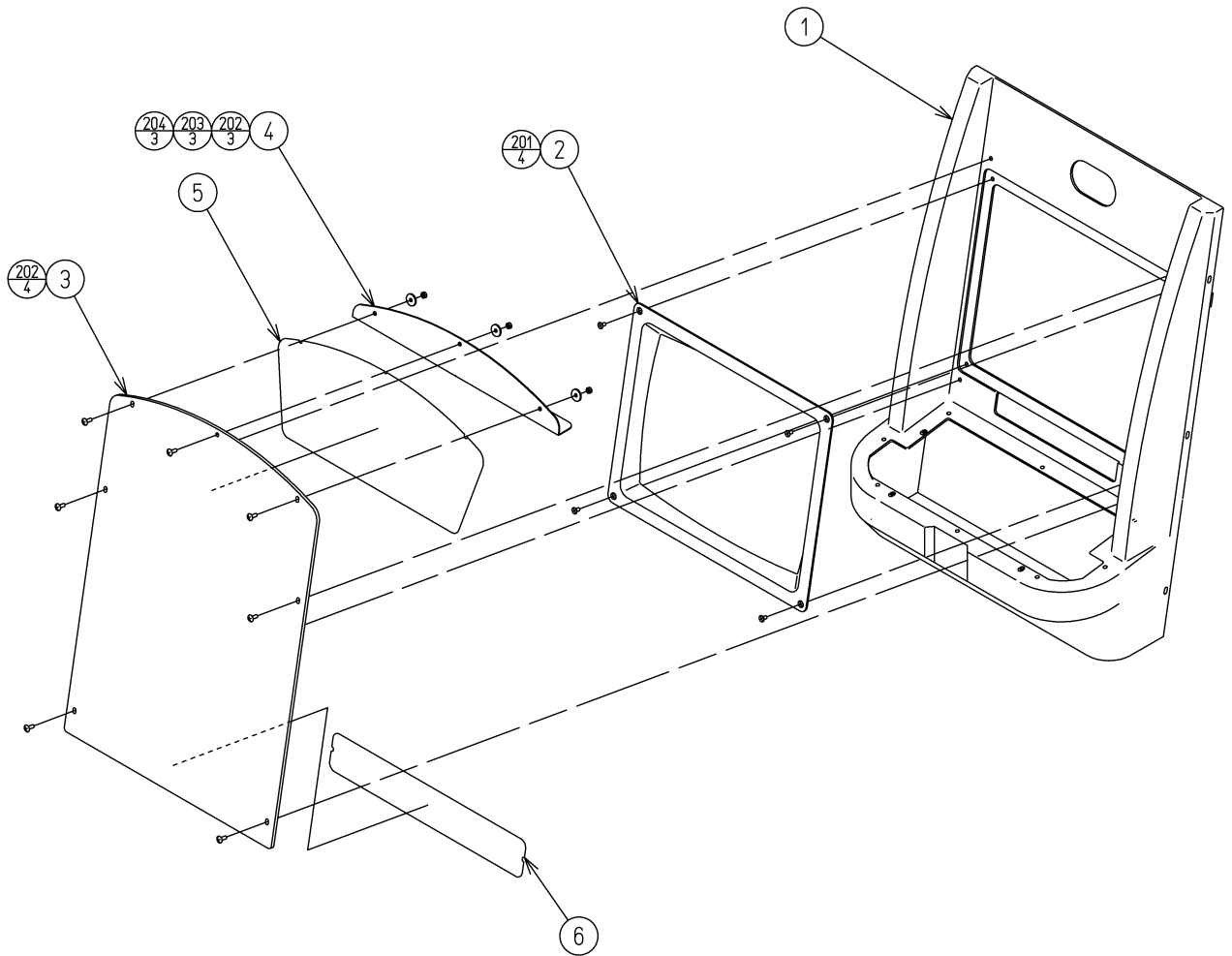

ITEM NO.	PART NO.	DESCRIPTION	NOTE
1	OSM-1701X	FRONT MASK	
2	TOE-NMD105	MONITOR MASK	
3	TOE-NMD110	MONITOR COVER PLATE	
4	DKT-1701	BOARD BRKT	
5	DKT-0007	DISPLAY SHEET DKT ENG	
6	4DKG-0006-01	PLAY INSTR SHEET DKG ENG	
201	000-F00408	M SCR FH M4X8	
202	000-T00412-0C	M SCR TH CRM M4 × 12	
203	050-C00400-3C	CUP NUT TYPE3 CRM M4	
204	068-441616-0C	FLT WSHR CRM 4.4-16 × 1.6	

⑫ ASSY RFID CHIP R/W (DKT-1800)

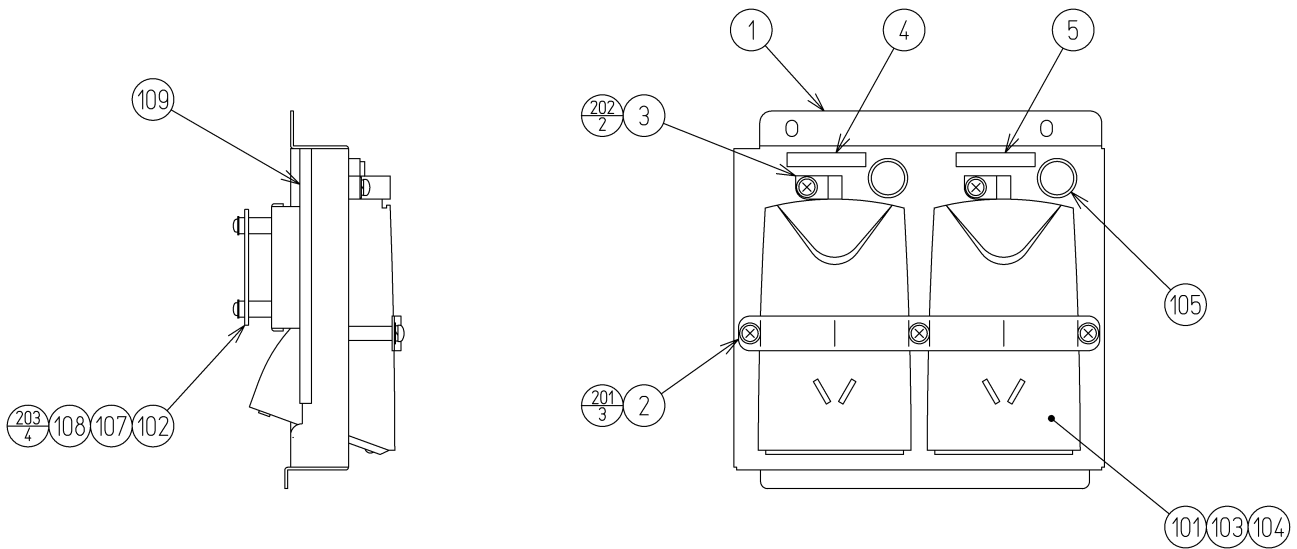

ITEM NO.	PART NO.	DESCRIPTION	NOTE
1	DKT-1801	RFID CHIP R/W BRKT	
2	MKG-0602	RFID CHIP R/W STAY	
3	DKT-1802	RFID CHIP HOLDER	
4	MKG-0604	STICKER EMPTY LAMP1	
5	MKG-0605	STICKER EMPTY LAMP2	
101	838-14243	RFID CHIP R/W BD	
102	838-14244	RS232C I/F BD	
103	253-7207	RFID CHIP R/W COVER FRONT	
104	253-7208	RFID CHIP R/W COVER REAR	
105	390-6821	LED GREEN DB-100-R1A06-G	
106	280-5292	CORD CLAMP PUSH TYPE	
107	280-5247	ONE TOUCH BUSHING	
108	280-5248	ONE TOUCH COLLAR M3 L=10	
109	601-6231-B-110	EDGING NEW TYPE	
201	000-P00308-W	M SCR PH W/FS M3×8	
202	000-P00412-W	M SCR PH W/FS M4×12	
203	010-P00320-F	S-TITE SCR PH W/F M3×20	
301	600-7265-02	WH SERIAL LINE	
302	DKT-60003	WH SECURITY UNIT	

⑬ ASSY CTRL PANEL (DKT-2000-01)

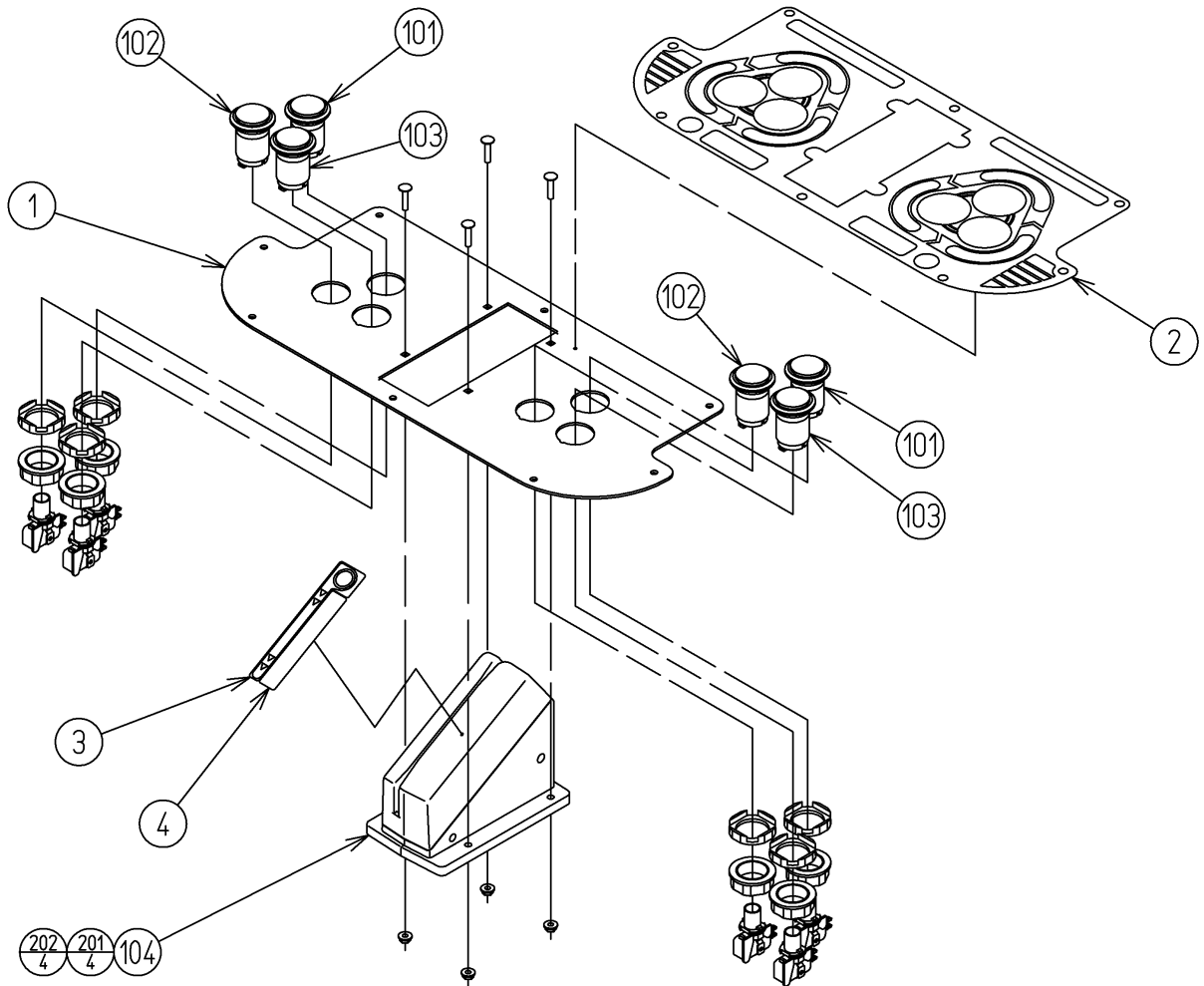

ITEM NO.	PART NO.	DESCRIPTION	NOTE
1	DKT-2001	CTRL PANEL PLATE	
2	4DKG-2002-01	STICKER CTRL PANEL DKG ENG	
3	DKT-2003-01	STICKER BARCODE RDR CASE ENG	
4	DKT-2004	STICKER C BARCODE RDR CS ENG	
101	509-6025-R-01	SW PB W/O LP CN R GUU	
102	509-6025-B-01	SW PB W/O LP CN B PAR	
103	509-6025-Y-01	SW PB W/O LP CN Y CHO	
104	610-0717	BARCODE READER VA	
105	280-5277	CORD CLAMP 18	
106	601-0460	PLASTIC TIE BELT 100MM	
201	031-00416-0C	CRG BLT CRM M4×16	
202	050-F00400	FLG NUT M4	
301	MKS-60007	WH CTRL PANEL SW	
302	MKG-60036-01	WH EARTH CTRL PANEL EXP	

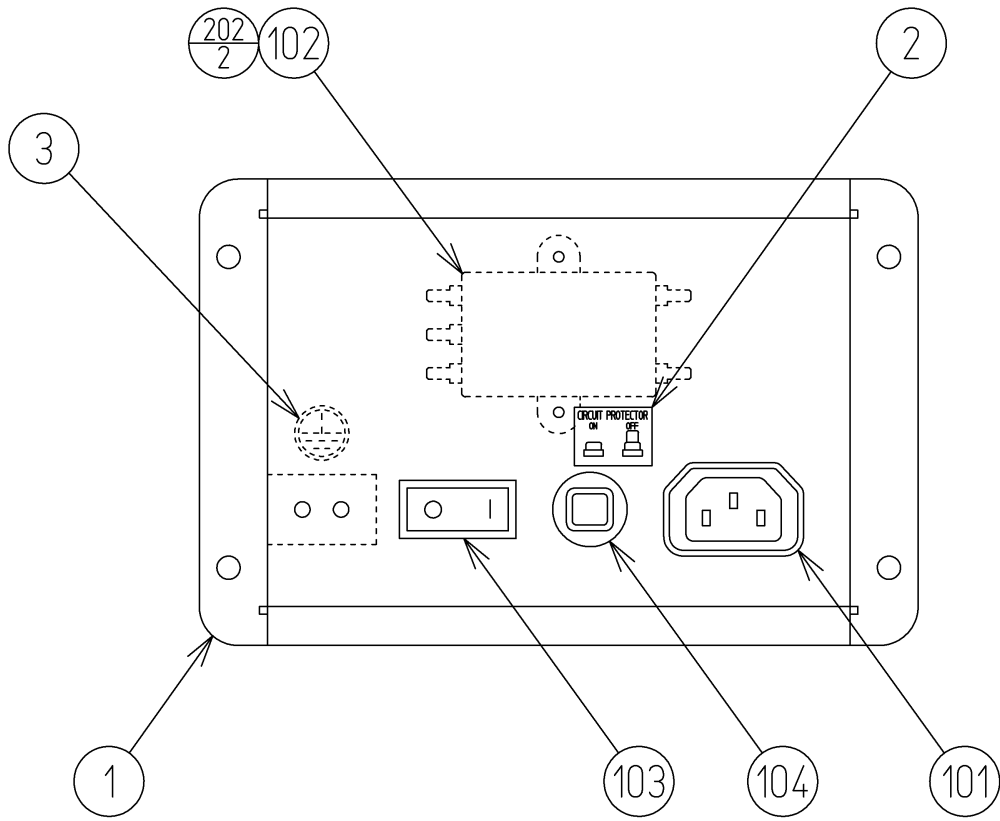
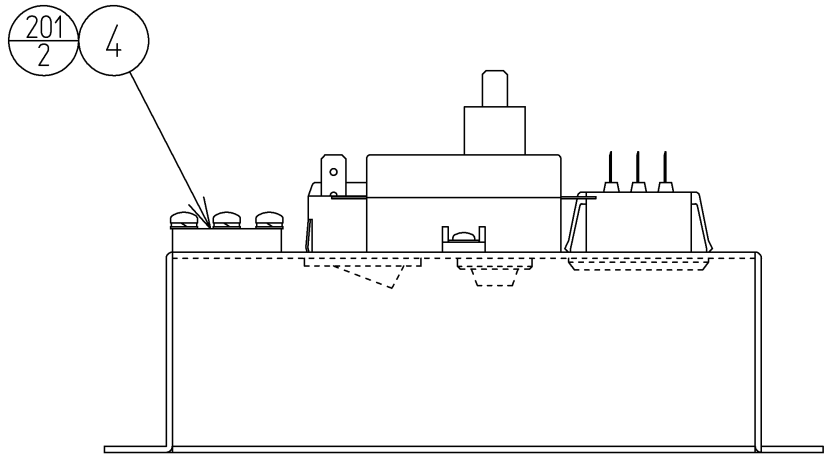

⑭ AC UNIT (DKT-4100)

(D-2/2)

ITEM NO.	PART NO.	DESCRIPTION	NOTE
1	MKG-4101-01	AC UNIT BASE EXP	
2	421-7468-02	STICKER C.P W/PIC	
3	421-8202	STICKER EARTH MARK	
4	117-5402-06-91	EARTH TERMINAL PLATE 6P	
101	214-0202	AC INLET PANEL TYPE	
102	270-5020	NOISE FILTER AC 250V 6A	
103	509-5453-91-H-B	SW ROCKER J8 H-B	
104	512-5046-3000	C.P 3000mA CE UL	
105	601-0460	PLASTIC TIE BELT 100MM	
106	310-5029-G20	SUMITUBE F G 20MM	
201	000-F00408	M SCR FH M4×8	
202	010-P00306-F	S-TITE SCR PH W/F M3×6	
301	DKT-60019	WH INLET L	
302	DKT-60020	WH AC UNIT J8 CONN	
303	DKT-60021	WH AC UNIT OUT	
304	MKG-60021-01	WH INLET E EXP	

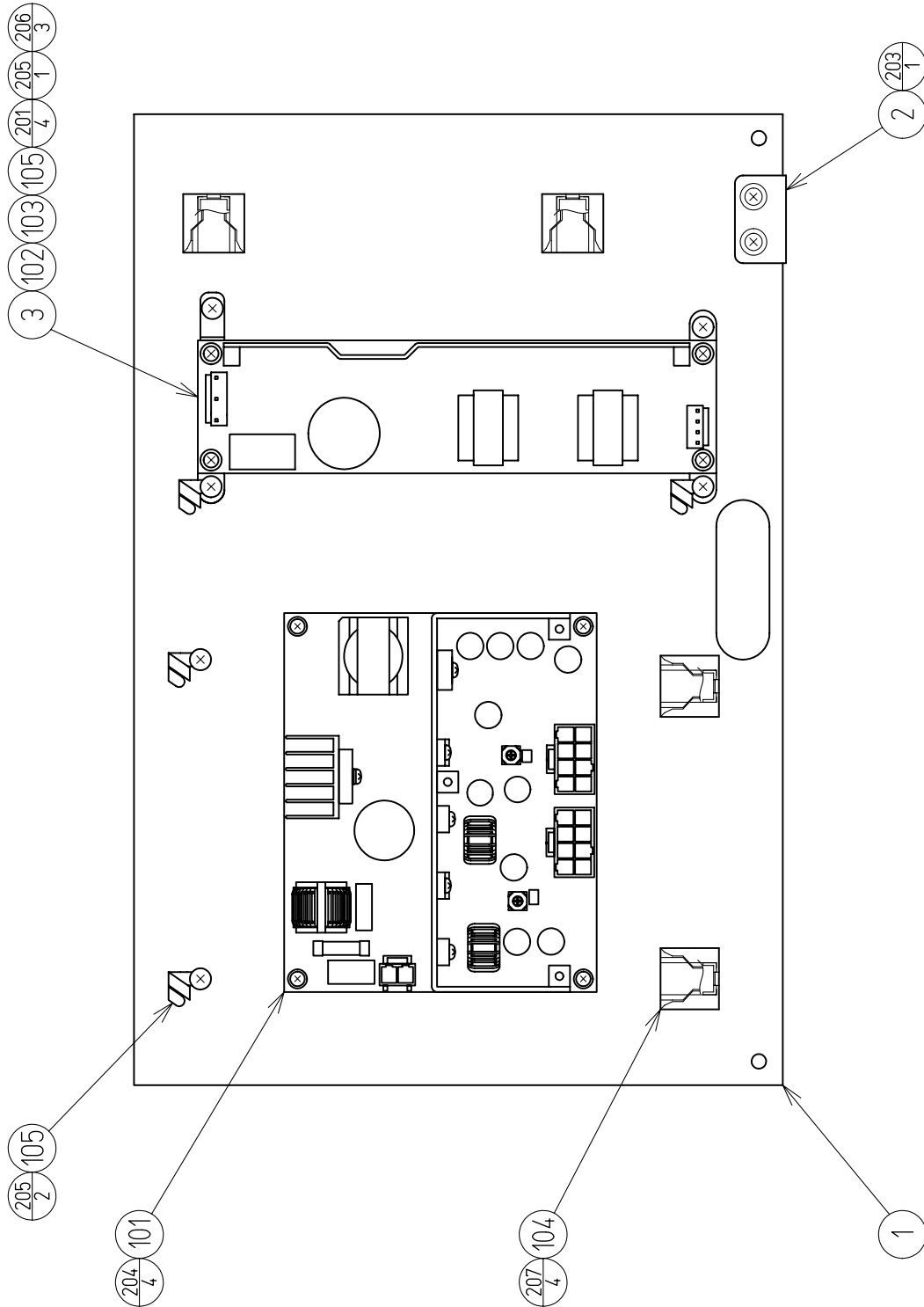

⑮ ASSY ELEC BASE (DKT-4200)

(D-2/2)

ITEM NO.	PART NO.	DESCRIPTION	NOTE
1	DKT-4201	ELEC BASE WOODEN	
2	DKT-4306	EARTH BRKT	
3	MKG-4207	BD BRKT	
101	400-5458	SW REGU 3.3V4.2A 5V4A 12V1.5A	
102	400-5421-05024	SW REGU LCA50S-24	
103	280-6681	L-LOCK LT-320PCG	
104	280-5277	CORD CLAMP 18	
105	280-5207	HARNESS LUG CC-1005	
201	000-P00308-W	M SCR PH W/FS M3×8	
202	000-P00408-W	M SCR PH W/FS M4×8	
203	000-P00412-W	M SCR PH W/FS M4×12	
204	011-P00325	TAP SCR PH 3×25	
205	011-T03512	TAP SCR TH 3.5×12	
206	011-T03516	TAP SCR TH 3.5×16	
207	011-F00312	TAP SCR FH 3×12	
301	MKS-60011	WH SW REGU AC	
302	MKS-60012	WH SW REGU DC	
303	DKT-60007	WH EARTH SW REGU 24V	

16 ASSY MAIN BD BASE (DKT-4300-02)

(D-1/2)

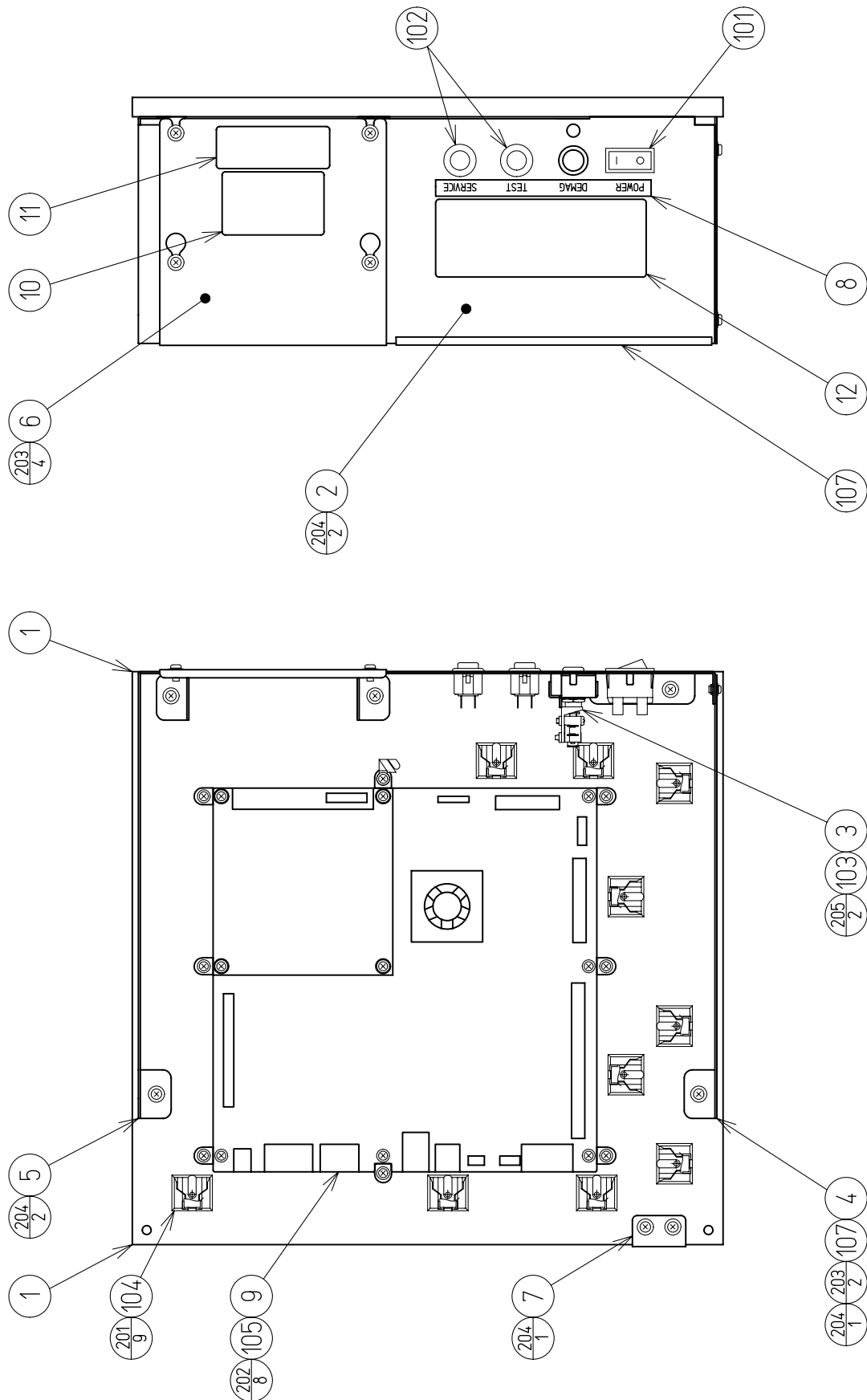

⑩ ASSY MAIN BD BASE (DKT-4300-02)

(D-2/2)

ITEM NO.	PART NO.	DESCRIPTION	NOTE
1	DKT-4301	MAIN BD BASE WOODEN	
2	DKT-4302	SW PANEL	
3	DKT-4303	SW BRKT	
4	OSM-4303	JOINT PLATE L	
5	DKT-4304	JOINT PLATE R	
6	DKT-4305	CF CARD LID	
7	DKT-4306	EARTH BRKT	
8	OSM-4306	STICKER SW PANEL	
9	834-14493-01	GAME BD SP DKG USA	
10	440-WS0215-EG	STICKER W BD POWER OFF S ENG	
11	440-WS0286-EG	STICKER W DO NOT OPEN ENG	
12	440-WS0291-EG	STICKER W DISPENSER ENG	
101	509-5453-91-H-B	SW ROCKER J8 H-B	
102	509-5875	SW PB (SINDEN SDP-103C)	
103	509-6085	SW PB VAQ-4R-K V-15-1A5 (TUV)	
104	280-5277	CORD CLAMP 18	
105	280-5207	HARNES LUG CC-1005	
106	601-0460	PLASTIC TIE BELT 100MM	
107	601-6231-B-195	EDGING NEW TYPE	
201	011-F00312	TAP SCR FH 3×12	
202	011-T03516	TAP SCR TH 3.5×16	
203	000-P00408-W	M SCR PH W/FS M4×8	
204	000-P00412-W	M SCR PH W/FS M4×12	
205	050-F00400	FLG NUT M4	
301	DKT-60022	WH SUB SW & DEMAG EXP	
302	MKS-60014	WH SYSTEM SP DC	
303	MKS-60015	WH MONITOR D-SUB15P	
304	MKS-60016	WH SP OUT	
305	MKS-60017	WH TEST & SERVICE SW	
306	OSM-60015	WH SYSTEM SP SERIAL	
307	DKT-60008	WH EARTH SW PANEL	

⑰ ASSY XFMR (DKT-4400-01)

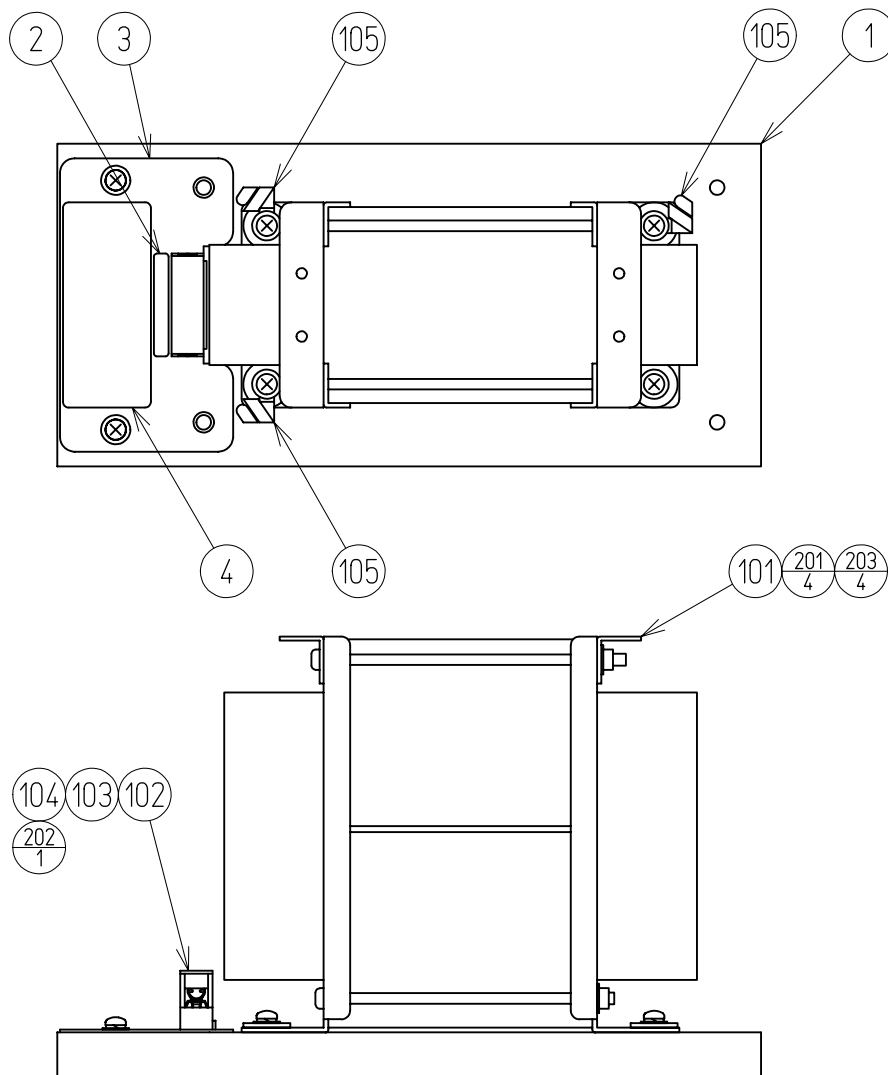

ITEM NO.	PART NO.	DESCRIPTION	NOTE
1	DKT-4401	XFMR BASE	
2	421-12071	STICKER FUSE RATINGS SG5013 T	
3	DKT-4402	FUSE HOLDER BASE	
4	440-CS0282-EG	STICKER C FUSE REPLACEMENT ENG	
101	560-5515-V-91	XFMR 100-120V 100V5A WB UL	
102	514-5138-4000	FUSE SG5013 5X20 4000MA 250V	
103	514-5144	FUSE HOLDER 1P F-64-AD	
104	514-5145	FUSE HOLDER COVER F-64-1C	
105	280-5207	HARNES LUG CC-1005	
201	000-P00416-W	M SCR PH W/FS M4×16	
202	FAS-000159	M SCR PH W/SMALL FS M3×8	
203	068-441616	FLT WSHR 4.4-16×1.6	
204	000-P00412-W	M SCR PH W/FS M4×12	
301	DKT-60005	WH FUSE HOLDER	

⑱ ASSY WH CABINET AC (DKT-6001)

This is comprised of the following wire harnesses. ASSY drawing is not available.

ITEM NO.	PART NO.	DESCRIPTION	NOTE
101	601-0460	PLASTIC TIE BELT 100MM	
301	MKS-60001	WH AC EXT	
302	DKT-60016	WH MONITOR & ELEC BASE	
303	DKT-60010	WH EARTH ASSY ELEC BASE	
304	DKT-60011	WH EARTH ASSY MAIN BD BASE	
305	MKG-60033-01	WH EARTH DOOR EXT EXP	

⑲ ASSY WH CABINET DC (DKT-6002)

This is comprised of the following wire harnesses. ASSY drawing is not available.

ITEM NO.	PART NO.	DESCRIPTION	NOTE
101	601-0460	PLASTIC TIE BELT 100MM	
301	MKS-60003	WH SYSTEM SP RA30P	
302	DKT-60017	WH SYSTEM SP RA60P	

⑳ ASSY WH DOOR (DKT-6005)

This is comprised of the following wire harnesses. ASSY drawing is not available.

ITEM NO.	PART NO.	DESCRIPTION	NOTE
101	310-5033-06-025	SPIRAL TUBE 06 ϕ 025CM	
101	601-0460	PLASTIC TIE BELT 100MM	
301	DKT-60018	WH DOOR	
302	DKT-60012	WH EARTH DOOR	

㉑ ASSY BILL VALIDATOR BOX (DKT-1900)

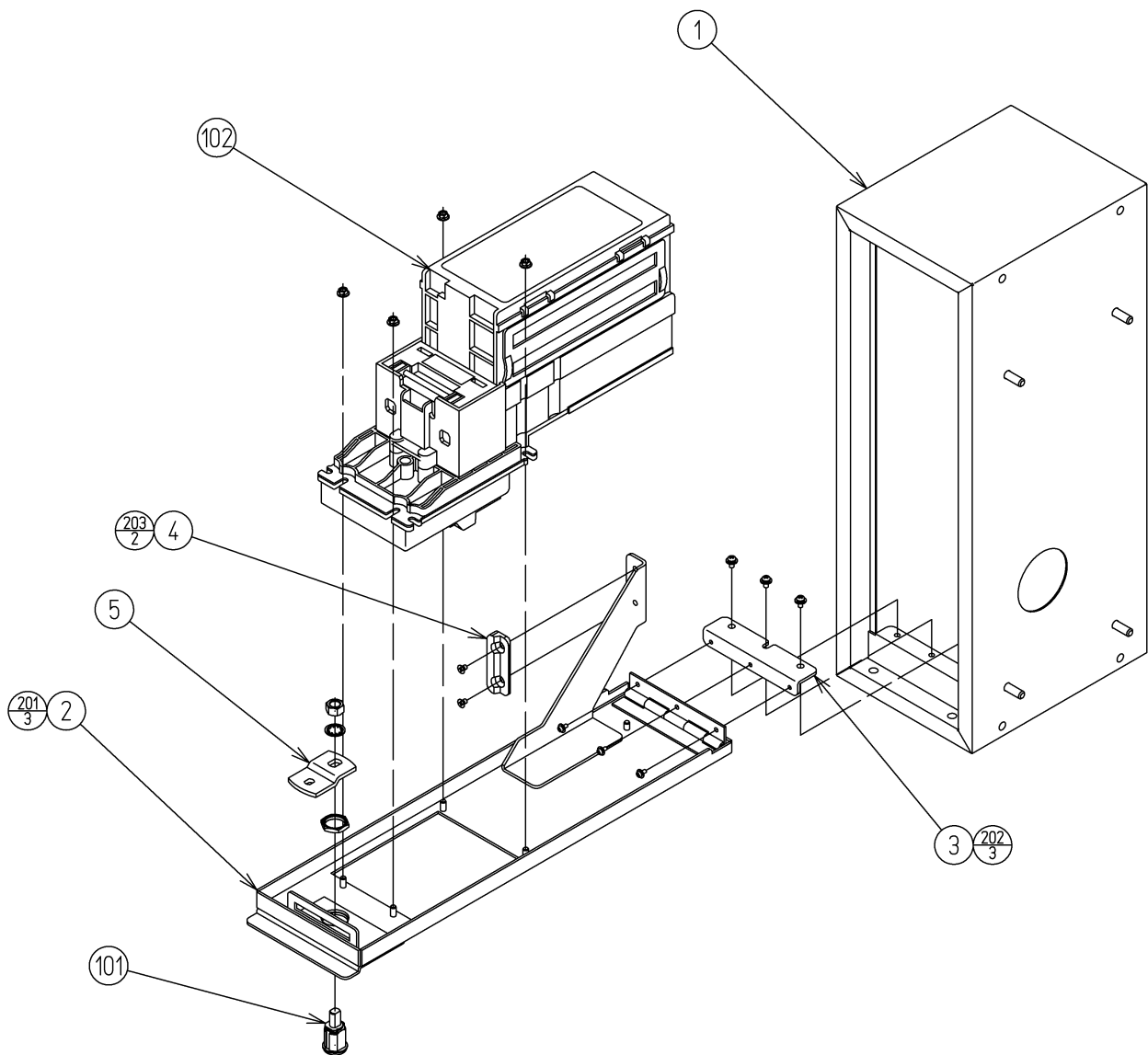

ITEM NO.	PART NO.	DESCRIPTION	NOTE
1	DKT-1901	BILL VALIDATOR BOX	
2	DKT-1902	BILL VALIDATOR BOX DOOR	
3	DKT-1903	HINGE BRKT	
4	DKT-1904	STOPPER GUIDE	
5	DP-1148X	LKG TNG	
101	220-5574	CAM LOCK W/KEYS	
102	601-1670	BILL VALIDATOR AE2431D5E MARS	
201	000-P00308-W	M SCR PH W/FS M3×8	
202	000-P00410-W	M SCR PH W/FS M4×10	
203	000-F00406	M SCR FH M4×6	
301	DKT-60006	WH EARTH DBA BOX DOOR	

FCC Part 15 and RSS-210:

This device complies with Part 15 of the FCC Rules. Operation is subject to the following two conditions:

- (1) this device may not cause harmful interference, and
- (2) this device must accept any interference received, including interference that may cause undesired operation.

FCC WARNING

Changes or modifications not expressly approved by the party responsible for compliance could void the user's authority to operate the equipment.

FCC Part 15 Subpart B Class A:

NOTICE

This equipment has been tested and found to comply with the limits for a Class A digital device, pursuant to part 15 of the FCC Rules. These limits are designed to provide reasonable protection against harmful interference when the equipment is operated in a commercial environment. This equipment generates, uses, and can radiate radio frequency energy and, if not installed and used in accordance with the instruction manual, may cause harmful interference to radio communications. Operation of this equipment in a residential area is likely to cause harmful interference in which case the user will be required to correct the interference at his or her own expense.

ICES-003

This class A digital apparatus complies with Canadian ICES-003.

Cet appareil numérique de la classe A est conforme à la norme NMB-003 du Canada.

22. WIRE COLOR CODE TABLE

THE WIRE COLOR CODE is as follow:

- A PINK
- B SKY BLUE
- C BROWN
- D PURPLE
- E LIGHT GREEN

Wires other than those of any of the above 5 single colors will be displayed by 2 alphanumeric characters.

- 1 RED
- 2 BLUE
- 3 YELLOW
- 4 GREEN
- 5 WHITE
- 7 ORANGE
- 8 BLACK
- 9 GRAY

If the right-hand side numeral of the code is 0, then the wire will be of a single color shown by the left-hand side numeral (see the above).

Note 1: If the right-hand side numeral is not 0, that particular wire has a spiral color code. The left-hand side character shows the base color and the right-hand side one, the spiral color.

<Example> 51.....WHITE/RED

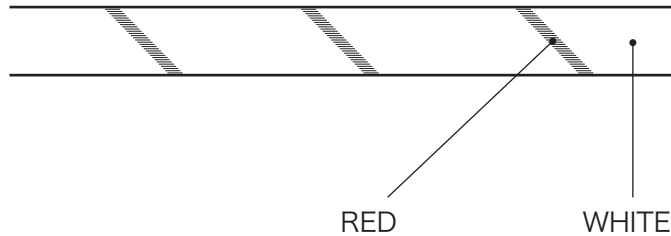

Note 2: The character following the wire color code indicates the size of the wire.

- U: AWG16
- K: AWG18
- L: AWG20
- None: AWG22

