



**SEGA®/Gremlin®**

# **FROGGER**

**Owner's Manual**  
**Manual Part No. 420-0647**

FROGGER<sup>™</sup>

OPERATING INSTRUCTIONS  
AND  
SERVICE MANUAL

MANUFACTURED BY

**SEGA<sup>®</sup>/Gremlin<sup>®</sup>**

TLX 910-335-1621

FROGGER OWNER'S MANUAL  
Copyright - 1981 by SEGA/Gremlin, All Rights Reserved

## INTRODUCTION

FROGGER is an electronic game that makes extensive use of digital integrated circuitry and television monitor concepts. This manual is designed for the maintenance technician who possesses a general knowledge of solid state circuitry, microprocessor and digital integrated circuitry, and TV monitor concepts. Any individual not knowledgeable in these areas should not attempt repair of the electronic portion of the game.

## IMPORTANT NOTES

The following note is included in compliance with FCC rules:

**WARNING:** This equipment generates, uses, and can radiate radio frequency energy and if not installed and used in accordance with the instructions manual, may cause interference to radio communications. As temporarily permitted by regulation, it has not been tested for compliance with the limits for Class A computing devices pursuant to Subpart J of Part 15 FCC Rules, which are designed to provide reasonable protection against interference in which case the user at his own expense will be required to take whatever measures may be required to correct the interference.

## TRANSFORMER VOLTAGE CONVERSION INSTRUCTIONS

Before plugging in your game, make sure that the game voltage is correct for your location. Locate the two leads from the AC junction box to the power transformer. For 110 VAC, they should be connected to terminals 1 and 3 on the power transformer. For 100 VAC, connect 1 and 2, and for 220 VAC applications, they should be connected to 1 and 4. You will also notice on the AC junction box that there is a safety interlock switch. When the rear panel is in place the switch is depressed and the game receives power. Removing the rear panel, the switch returns to its original position and the power is cut off from the game. For servicing, this switch can be pulled out and power will be restored.

## OTHER NOTES

NEVER replace any components with anything other than exact replacement parts.

NEVER remove circuit board connections while power is on.

DO NOT replace the fuse with anything other than the proper value. A blown fuse indicates an overload condition within the game. Replacing the fuse with a higher value can cause severe damage to internal components if an overload occurs.

ALWAYS consult the manual before attempting repairs.

CORRESPONDENCE regarding this game should be addressed to:

SEGA/Gremlin

8401 Aero Drive

San Diego, California 92123

800-854-1099

## FROGGER GAME CONCEPT

Frogger is a one or two player game in which players move their frog from the bottom to the top of the screen. This is achieved by overcoming a number of hazards without getting run over or drowned.

The first half of the screen is a bi-directional flow of traffic including buses, cars and race cars. Players must avoid these vehicles. Frogs can move safely with the flow of traffic to make their way to the second half of the screen which consists of a river with fast moving logs and sinkable turtles. Frogs must hop on the backs of the logs and the sinkable turtles to get to the home base at the top of the screen. At random times throughout the game play a lady frog will appear on a log. Bonus points are scored if your frog successfully hops on the back of the lady frog and escorts her safely home. A fly will also appear randomly in a home base. Bonus points can be scored if your frog hops in the home base when the fly is present. Sinking turtles also swiftly move across the river with the logs. If a frog is unsuccessful in hopping on a turtle's back, the frog will sink and drown. Crocodiles, snakes and otters also roam the moving river waiting to eat frogs on their way up to the home base. Players can hop on their back (except the snake, whose touch is deadly), but they must avoid their open mouths. The frog must be lined up perfectly to enter one of the five home bases. You must maneuver the frogs to their home base within the allotted time (sixty beats on the timer).

### Game Action

The frog can move vertically or horizontally by maneuvering the joystick. You must maneuver your frog swiftly and precisely without getting run over, drowned or eaten by the creatures that roam the flowing river. Avoiding traffic, deadly snakes, otters, crocodiles and the treacherous diving turtles make game action stimulating in Frogger.

### Scoring

10 points are scored for each safe jump. Arriving safely home scores 50 points and for beating the timer (10 points per beat saved). Bonus points are obtained by escorting home a lady frog (200). Gobbling an insect (200) and safely getting all five (adjustable) frogs home (1000). If you get all five (adjustable) frogs home, then you go on to a swifter more difficult round. Game ends when all frogs are drowned or devoured.

## FROGGER GAME OPTIONS

<u>GAME OPTIONS</u>	<u>1</u>	<u>2</u>	<u>3</u>	<u>4</u>	<u>5</u>	<u>6</u>
3 FROGS	ON	ON	X	X	X	X
5 FROGS	ON	OFF	X	X	X	X
7 FROGS	OFF	ON	X	X	X	X
256 FROGS	OFF	OFF	X	X	X	X
UPRIGHT	X	X	ON	X	X	X
COCKTAIL	X	X	OFF	X	X	X

### COIN/CREDIT OPTIONS

#### Coin Mech 1

1 coin/1 play	X	X	X	ON	ON	X
2 coin/1 play	X	X	X	ON	OFF	X
2 coin/1 play	X	X	X	OFF	ON	X
1 coin/1 play	X	X	X	OFF	OFF	X

#### Coin Mech 2

1 coin/1 play	X	X	X	ON	ON	X
2 coin/1 play	X	X	X	ON	OFF	X
1 coin/5 play	X	X	X	OFF	ON	X
1 coin/6 play	X	X	X	OFF	OFF	X

X = Doesn't Matter

# TROUBLE SHOOTING

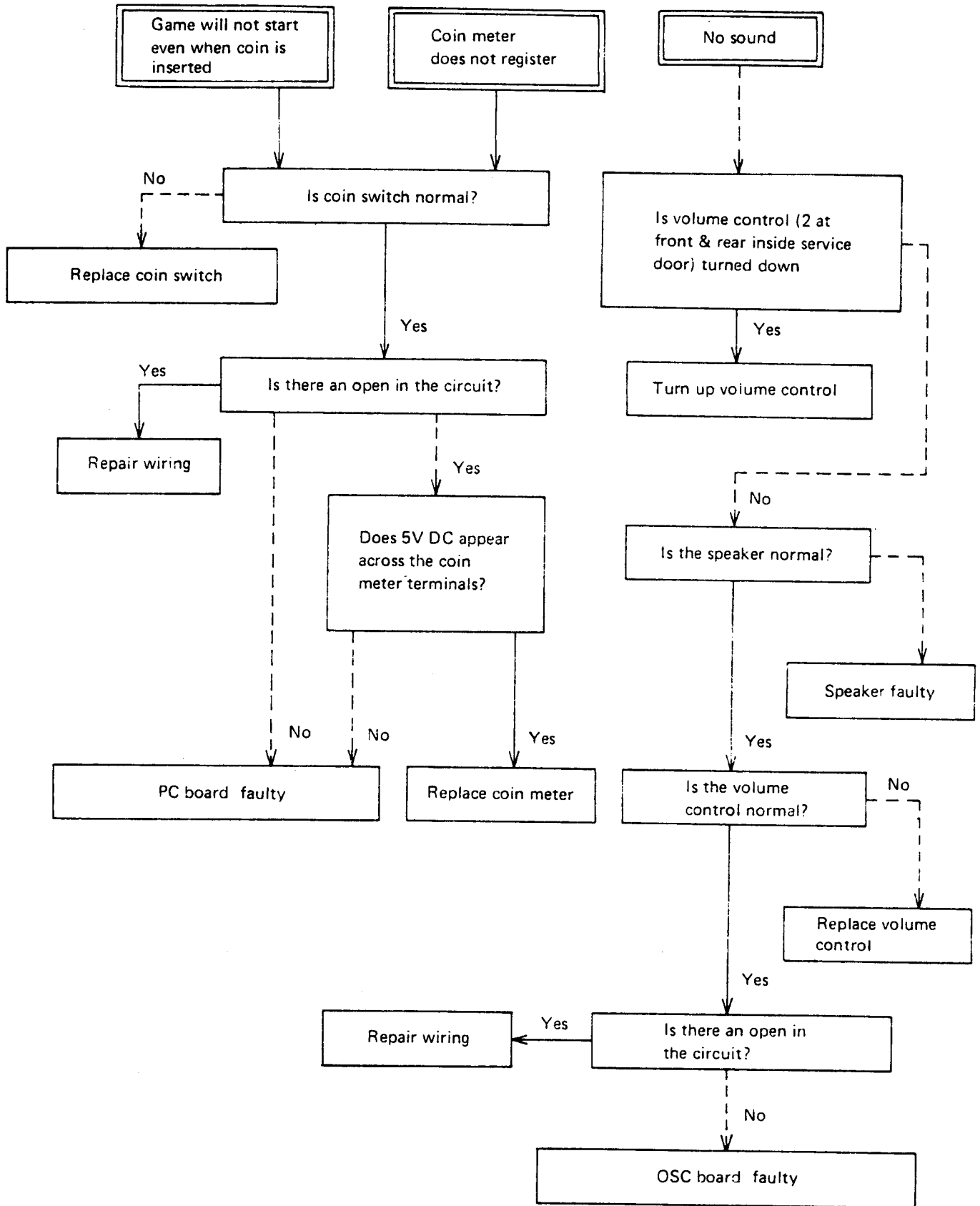



# 1. 834-0068 SYNC. RELATION FAULTY

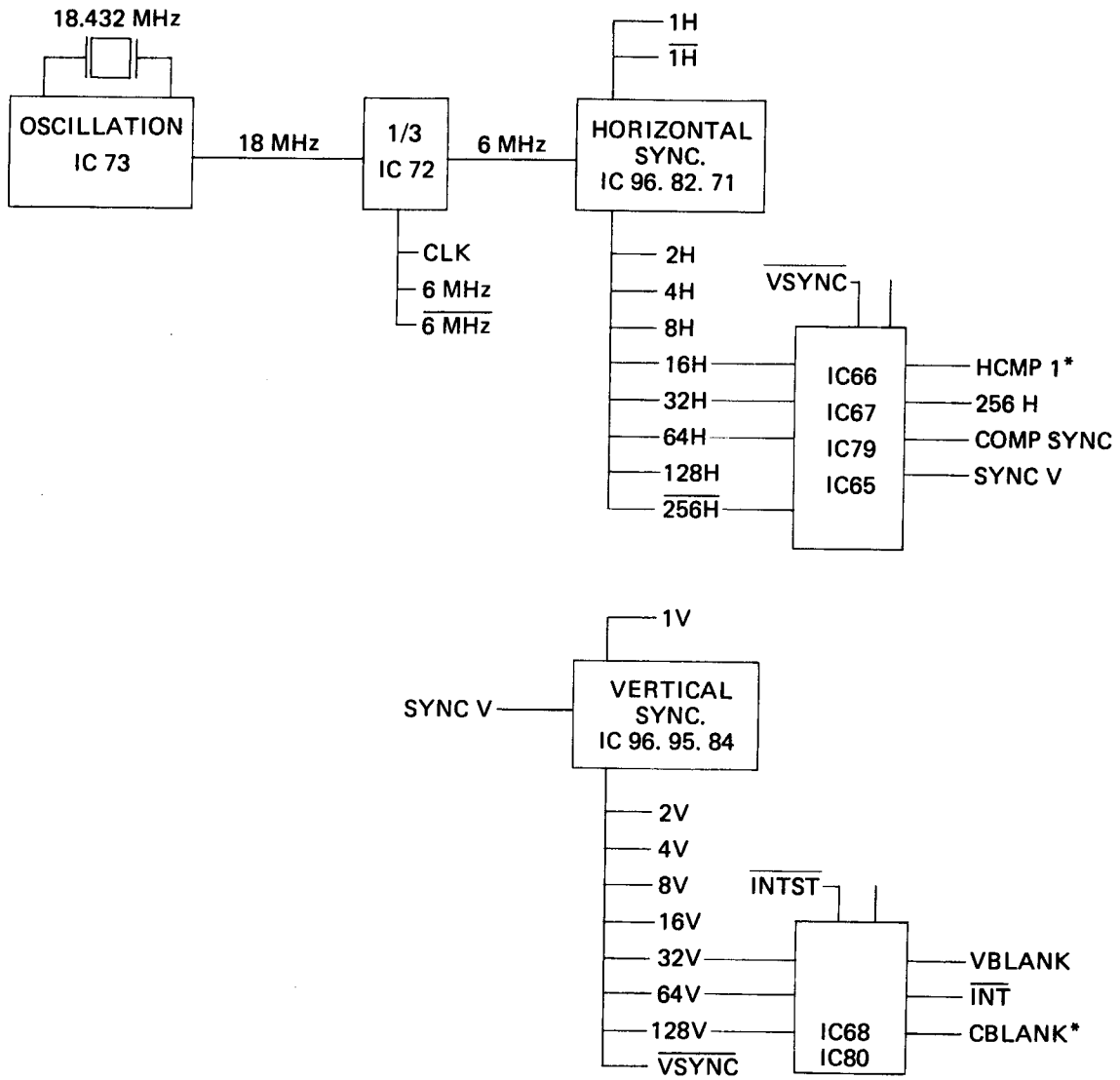

BLOCK DIAGRAM FOR OSCILLATION, HORIZONTAL · VERTICAL SYNC.

a. PICTURE DRIFTS AWAY

IT COULD POSSIBLY BE THE FAULT FROM THE SYNCHRONIZING CIRCUIT.  
FOLLOW THE FLOW CHART BELOW FOR INSPECTION.

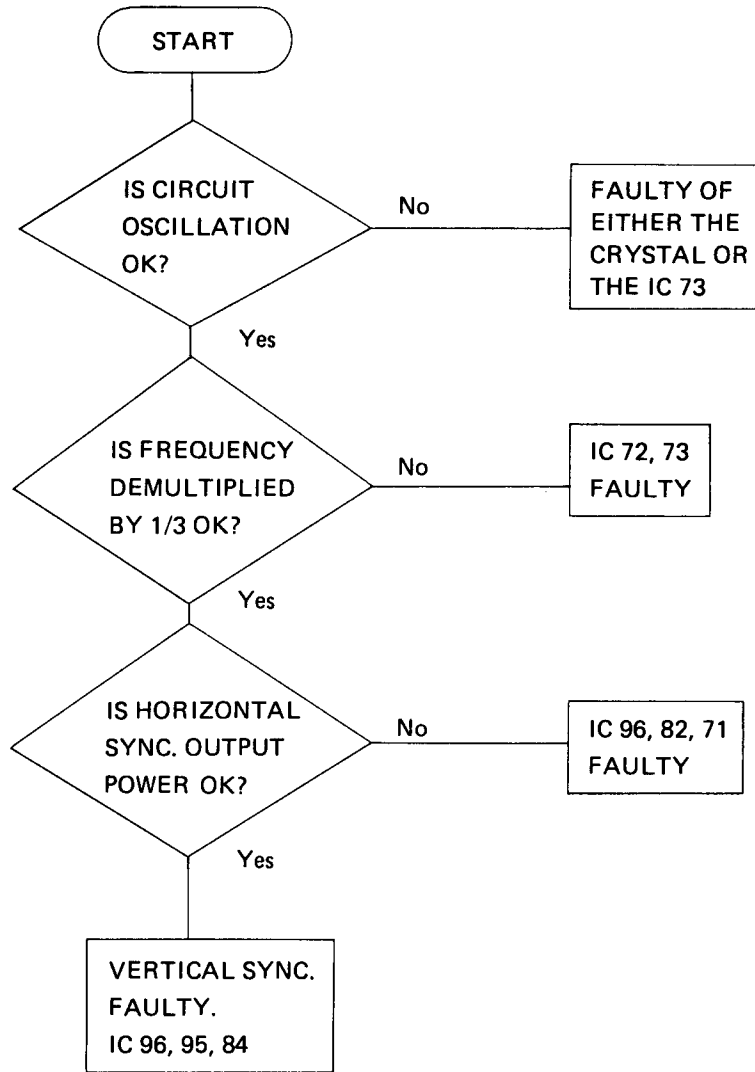

b. PICTURE WILL NOT APPEAR

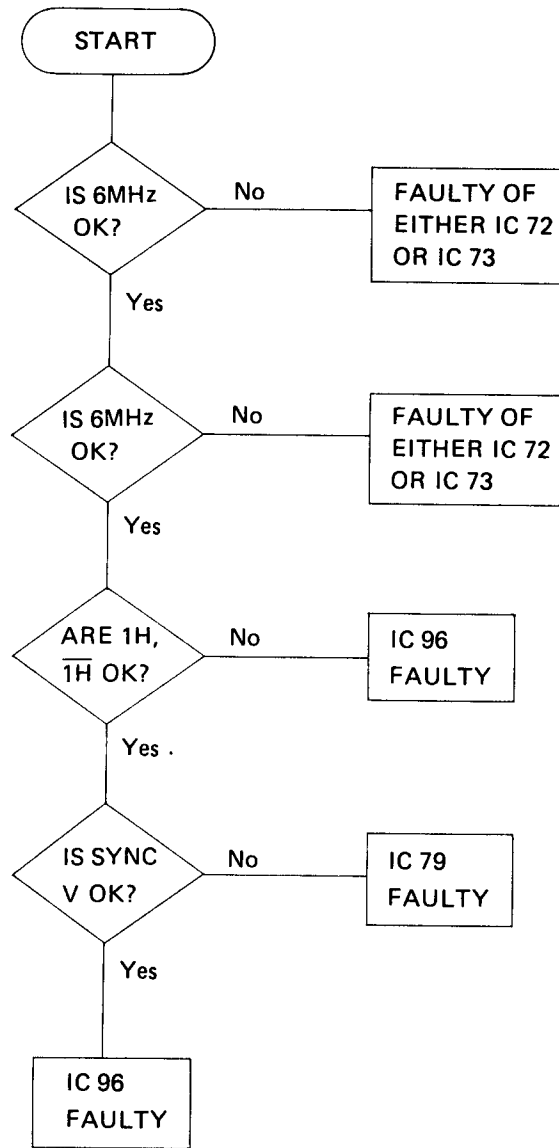

## 2. RESET FAULTY

### a. WHEN GAME STARTS, PICTURE DISAPPEARS.

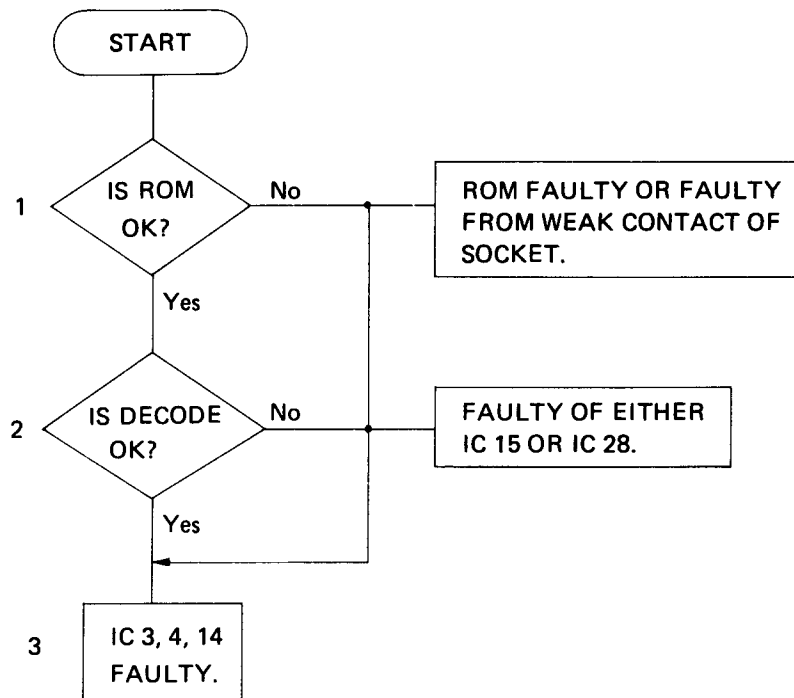

- 1 IS THE CHIP SELECT OF ROM FUNCTIONING PROPERLY?  
IS THE ADDRESS DATA BUS FUNCTIONING PROPERLY?
- 2 ARE THE OUTPUT POWER PIN 12, 13, 14, 15 OF IC 15 FUNCTIONING PROPERLY?  
ARE THE INPUT POWER PIN 1, 2, 3, 4, 5, 6 OF IC 15 FUNCTIONING PROPERLY?  
CHECK ESPECIALLY ON 6TH PIN OF IC 30 TO THE 4TH, 5TH PIN AS WELL.  
ARE PINS 10, 13, 14, 15 OF IC 28 NORMAL.
- 3 BUFFER FOR ADDRESS BUS OF IC 3, 4, 14 FAULTY?  
ESPECIALLY, TOO MUCH FAULTY OF TEMPERATURE.

**b. WHEN INSERTING COIN, IT RESETS.**

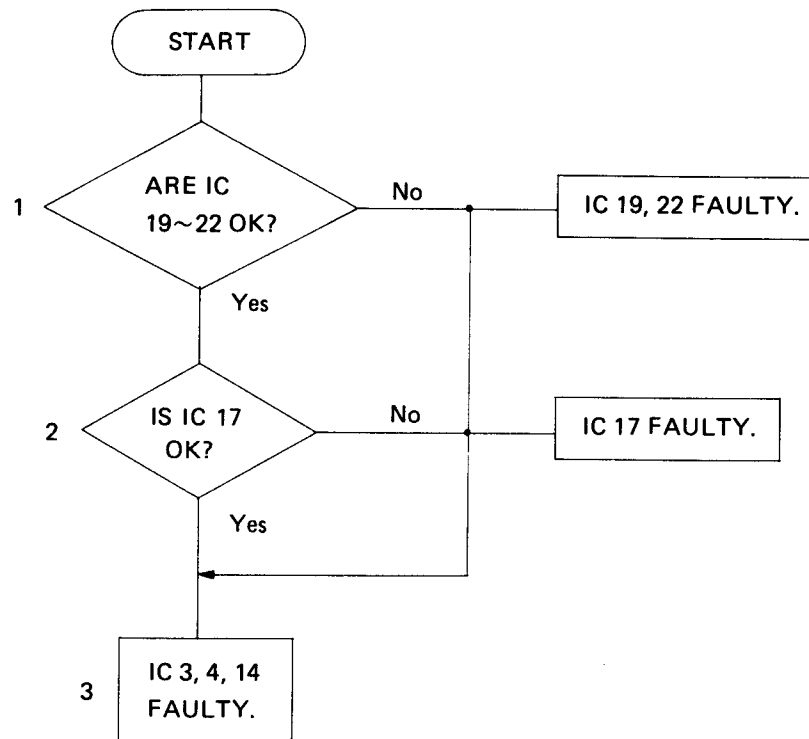

- 1 IS THE CHIP SELECT (8 PIN) OF IC 19, 20, 21, 22 FUNCTIONING PROPERLY?  
IS THE ADDRESS DATA BUS FUNCTIONING PROPERLY?
- 2 ARE THE INPUT POWER SIDE OF 1, 2, 3, 4, 5, 6 PIN OF IC 17 NORMAL?  
FOR 6 PIN, CHECK ALSO 4, 5 PIN OF IC 30.
- 3 BUFFER FOR ADDRESS BUS OF IC 3, 4, 14 FAULTY.

### 3. COLOR FAULTY

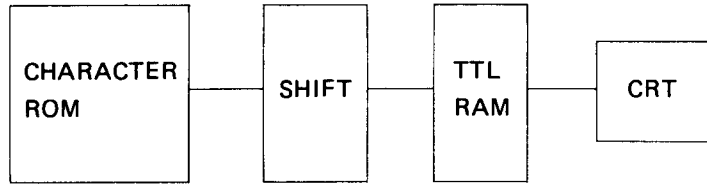

#### 1. COLOR HORIZONTAL LINE APPEARS.

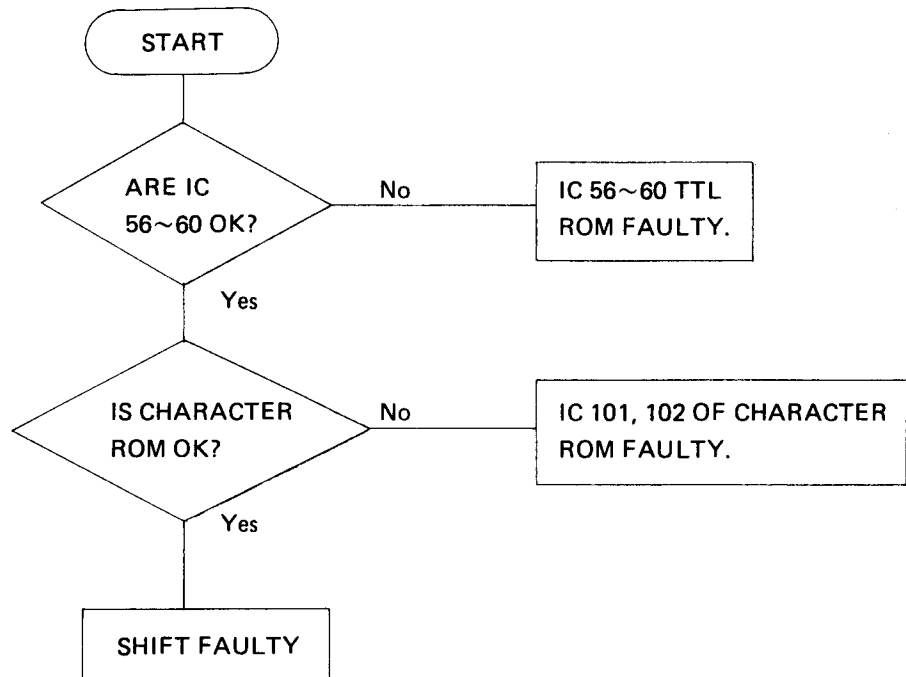

1 MANY TEMPERATURE FAULTY IN TTL-ROM OF IC 56, 57, 58, 59, 60.

2 FAULTY OF EITHER CHARACTER ROM OR WEAK CONTACT OF SOCKET.

2. WHEN THE COLOR IS LIGHT OR NO COLOR.  
 FAULTY OF IC 61 FUSE ROM 6331-1.

3. THE WHOLE ENTIRE COLOR IS DIFFERENT.

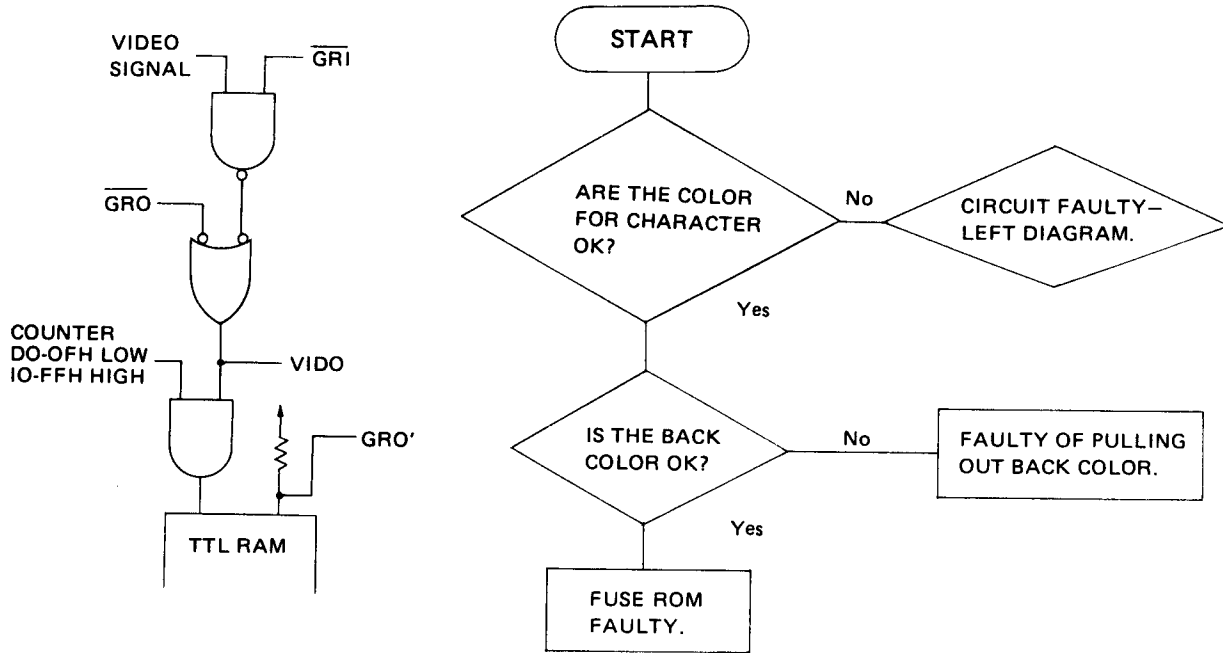

- 1 IN THIS CIRCUIT DIAGRAM, THE COLOR HAS ALREADY BEEN DECIDED FOR THE CHARACTERS.  
 FOLLOW THE SIGNAL LINES CAREFULLY.  
 THESE ARE THE SIGNAL LINES FROM THE RESULT OF GATES DESTROYED.
- 2 PULLING OUT OF BACK COLOR CAN BE DONE THROUGH IC 92, 82.

## 4. VIDEO FAULTY

### 1. PICTURE MOSAIC

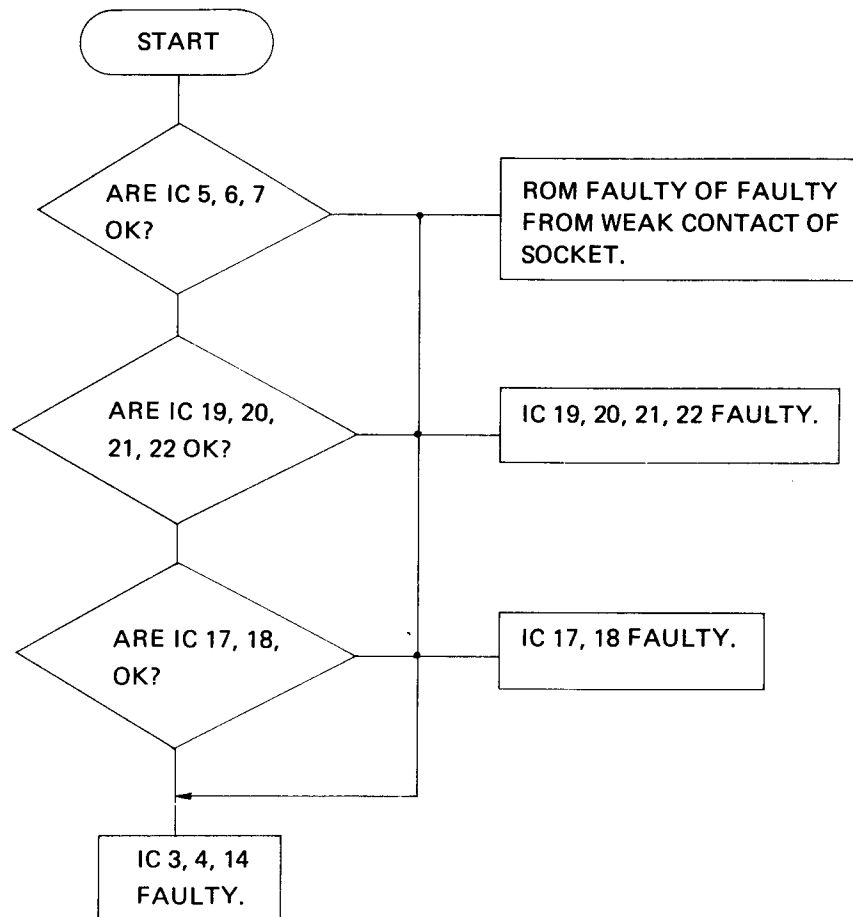

1 2 IS CHIP SELECT WORKING PROPERLY?  
IS THE ADDRESS DATA BUS NORMAL?

3 ARE THE INPUT/OUTPUT POWER OF DECODE NORMAL?  
FOR 6 PIN, CHECK ON 4, 5 PIN OF IC 30.



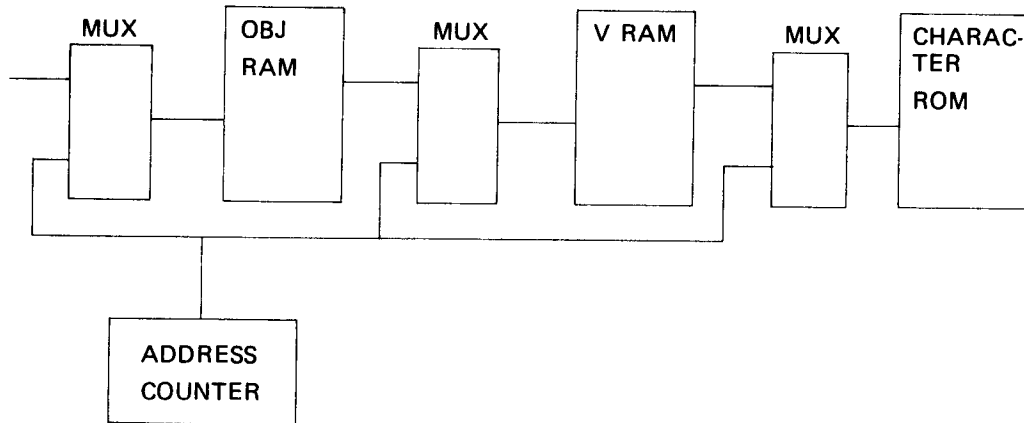

2. **THE SCREEN IS SHOWN HORIZONTALLY DOUBLED & TRIPLED.**
  - V RAM OF MUX – SURROUNDING (CIRCUMFERENCE)  
IC 76, 87, 97, 98, 99
  - CHARACTER ROM – SURROUNDING (CIRCUMFERENCE)
  
3. **THE SCREEN IS SHOWN VERTICALLY DOUBLED, TRIPLED . . . . ETC.**
  - INVERSION FAULTY IC 70, 80
  
4. **WORDS APPEAR ON SCREEN.**
  - OFF-TIMING OF V RAM. IC 74, 75.
  
5. **INVERSION FAULTY OF WORDS FOR 2 PLAYERS.**
  - IC 42, 43, 61, 70, 81.
  
6. **OFF-POSITIONING OF CHARACTER OR WHEN CHARACTER (SUCH AS FROGS) DO NOT APPEAR.**
  - ADDRESS BUS WORKING FROM OBJ-RAM TO TTL ROM FAULTY.  
IC 37, 47, 48, 49.
  
7. **CHARACTER TURNS INTO NUMBER.**
  - ADDRESS COUNTER OF TTL RAM FAULTY.  
IC 37, 49.
  - OFF-TIMING (V) FAULTY OF V RAM.  
IC 76, 77.
  
8. **TURNS INTO MOSAIC AT TIMES WHEN SHIFTING THE CHARACTERS.**
  - FAULTY OF DATA SELECTOR INSERTED IN CHARACTER ROM.  
IC 88, 89, 90.

# 834-0069 - TROUBLESHOOTING

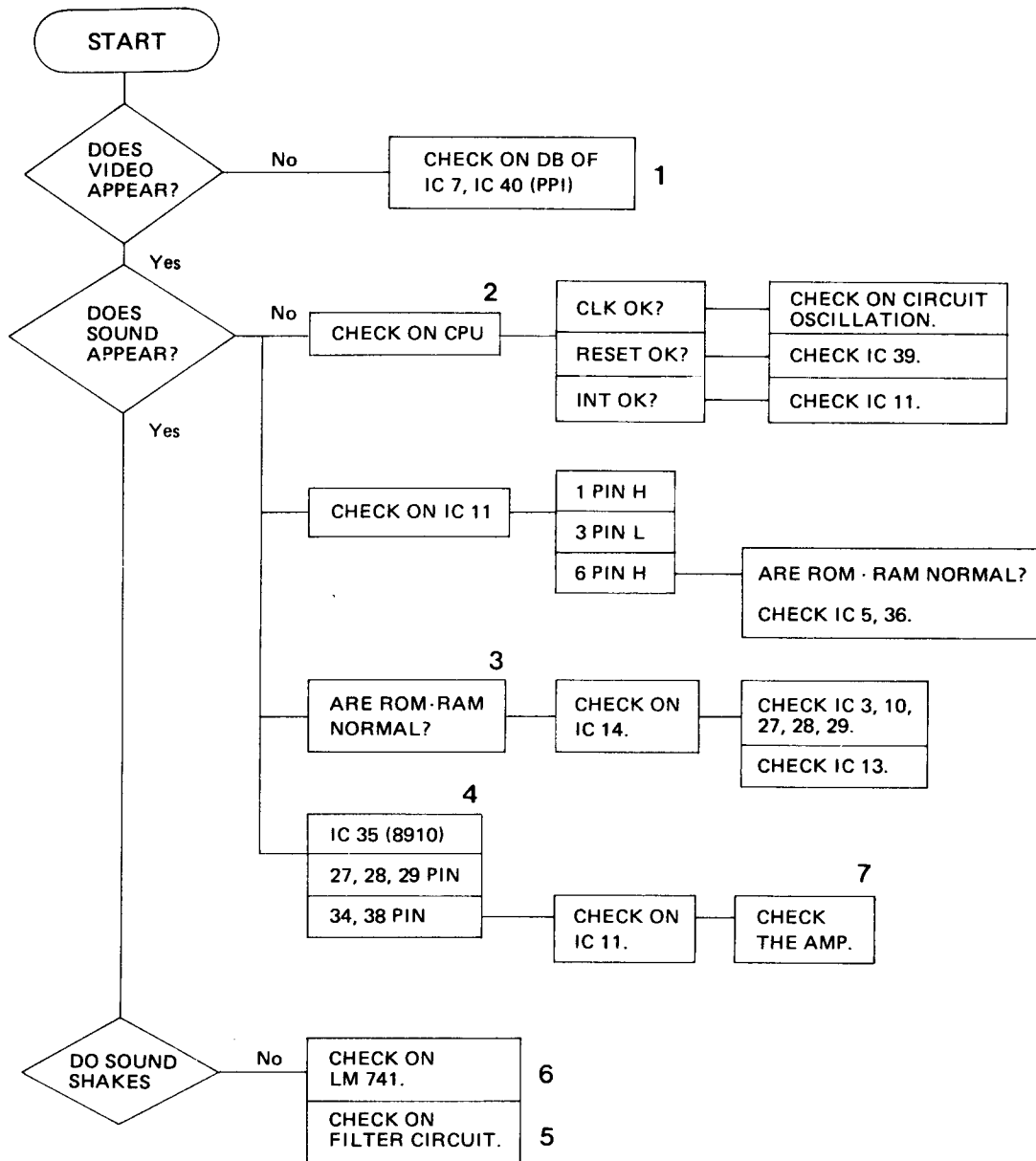

**1. CHECK ON PPI**

- CHECK ON CHIP SELECTOR (6 PIN)
- CHECK ON  $\overline{RD}$  (5 PIN),  $\overline{WR}$  (36 PIN)

**2. CHECK ON CPU SURROUNDING**

- CHECK CLK ABOUT (APPROXIMATELY) 1.8MHz
- CHECK ON CIRCUIT OSCILLATION
- CHECK ON  $\overline{RESET}$  L → H  
IC 39, 8, 9 PIN
- CHECK ON  $\overline{INT}$   
IC 11 1 PIN H  
3 PIN L  
6 PIN H  
CHECK IC 5, 36

**3. CHECK ON ROM, RAM**

- CHECK ON CHIP SELECT ROM (20 PIN) RAM (8 PIN)
- CHECK ON ACTION
- CHECK THE ADDRESS DATA BUS.
- CHECK THE I/O POWER OF IC 3, 10, 27, 28, 29

**4. CHECK ON P.S.G. (8910)**

- CHECK CLK (22 PIN) ABOUT (APPROXIMATELY) 1.8MHz
- CHECK THE INPUT POWER OF 6, 7, 9, 10 PIN ON PORT B
- CHECK BC1 (29 PIN) BC2 (28 PIN) BD1R SIGNAL  
BC1 → L BC2 → SIGNAL BD1R → SIGNAL
- CHECK ANALOG (ANALOGUE) OUTPUT POWER CHA (3 PIN)  
CHB (4 PIN) CHC (38 PIN)  
CHA → SIGNAL CHB → SIGNAL

**5. CHECK THE FILTER**

- HOW ABOUT THE JOINING CONDITION TO CAPACITOR RESISTANCE?
- IS FILTER CONTROL OK?  
IC 18, 19, 20

**6. CHECK THE ACTION TO LM741**

**7. CHECK M51516L**

- HOW ABOUT THE JOINING CONDITION TO CAPACITOR RESISTANCE?
- CHECK THE ACTION OF 3 PIN (USUALLY HIGH)  
IS OUTPUT POWER OK? 8, 9 PIN

TOP ASSEMBLY

DRAWING NUMBER 700-0066

<u>ITEM NO.</u>	<u>PART NO.</u>	<u>QTY REQD.</u>	<u>DESCRIPTION</u>
1	700-0051	1	Woodgrain Upright SEGA Game Assembly
2	800-3183	1	Frogger Assembly Kit

# Top Assembly 700-0066

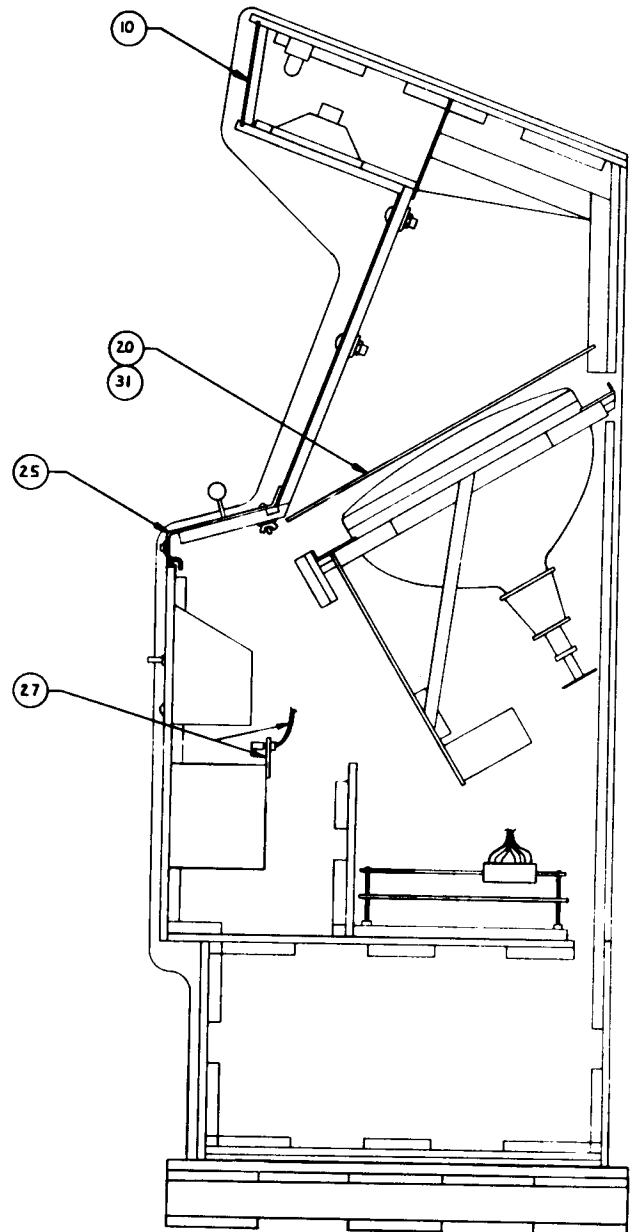
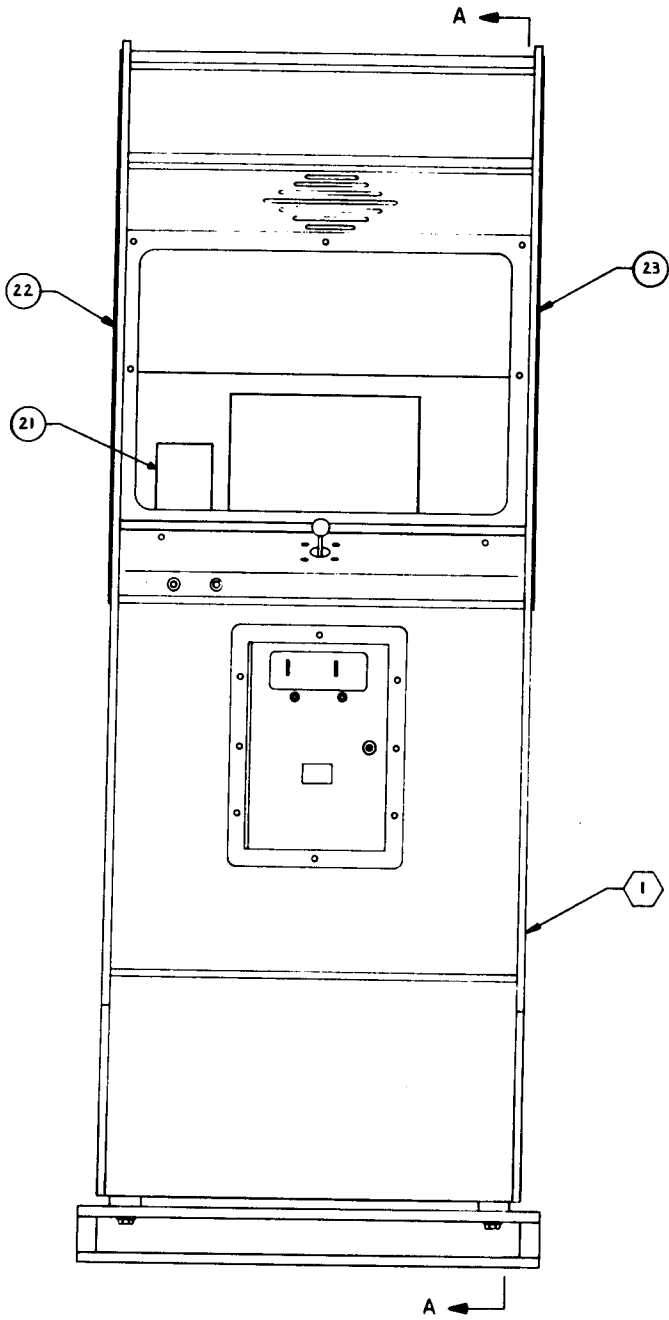

SECTION A - A

# Top Assembly 700-0066

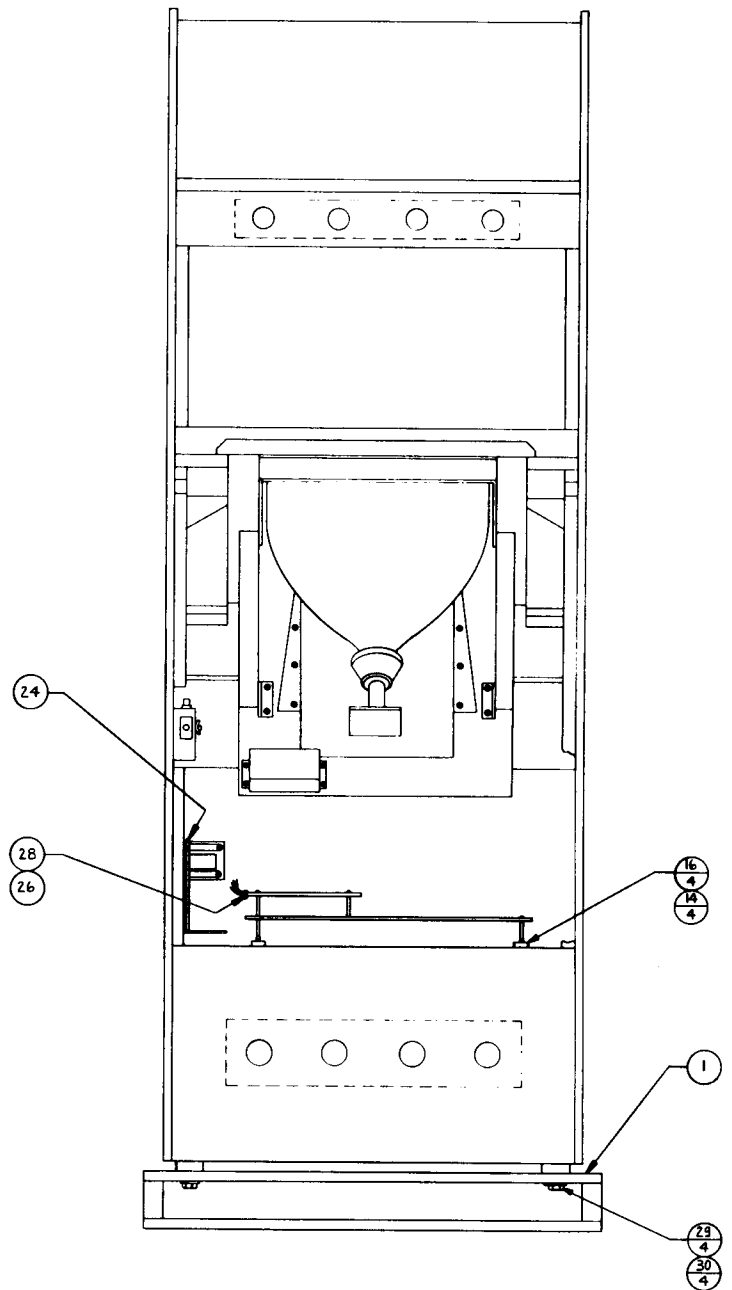
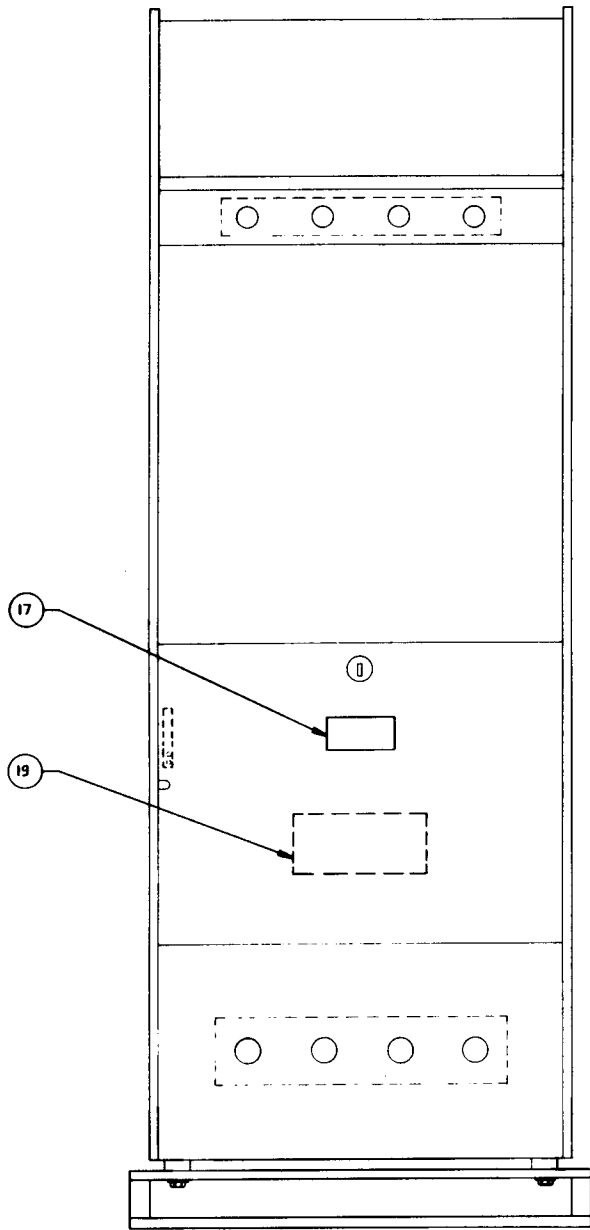

TOP ASSEMBLY

DRAWING NUMBER 700-0067

<u>ITEM NO.</u>	<u>PART NO.</u>	<u>QTY REQD.</u>	<u>DESCRIPTION</u>
1	700-0040	1	Woodgrain Upright Game Assembly
2	800-3182	1	Frogger Assembly Kit

# Top Assembly 700-0067

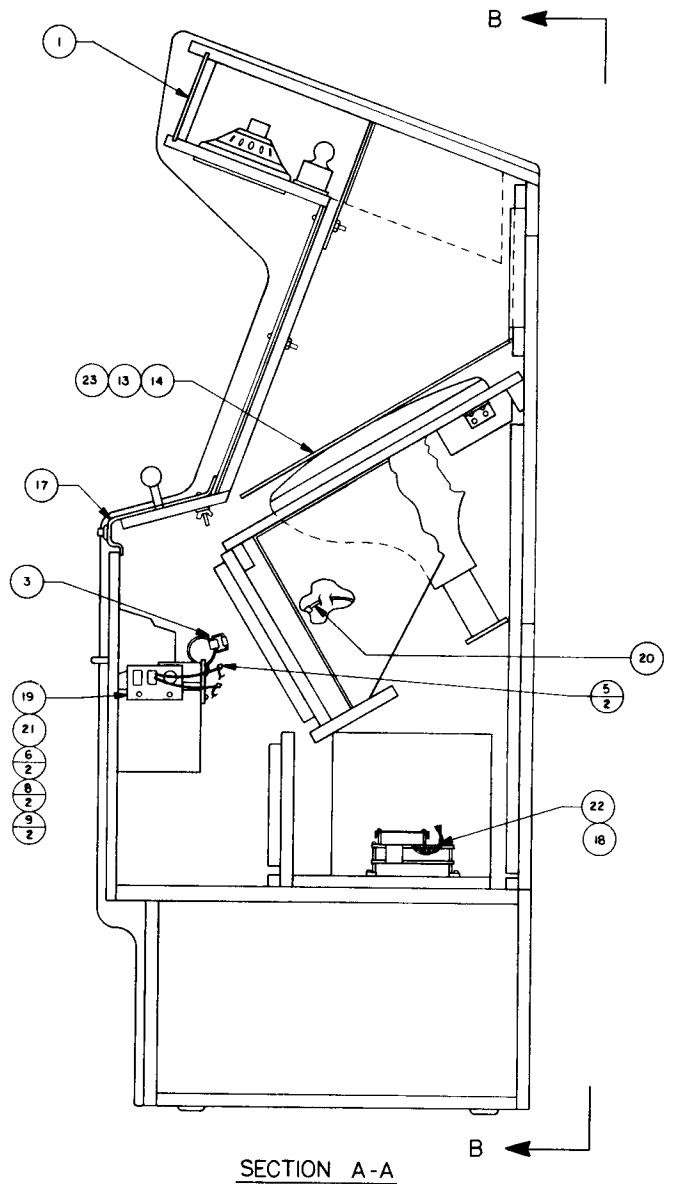
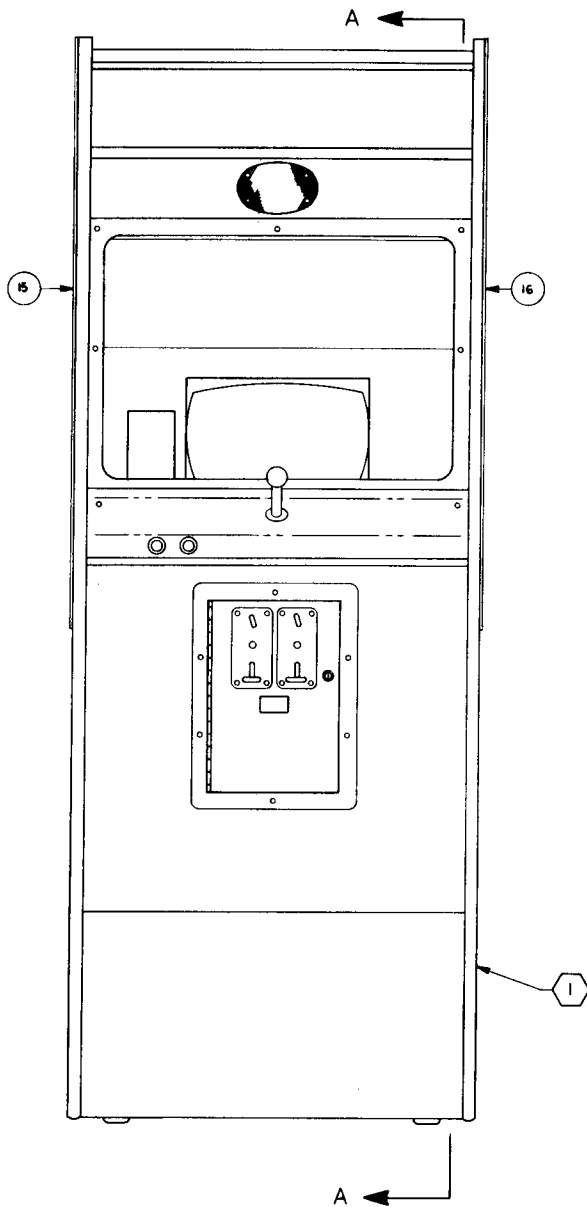



# Top Assembly 700-0067

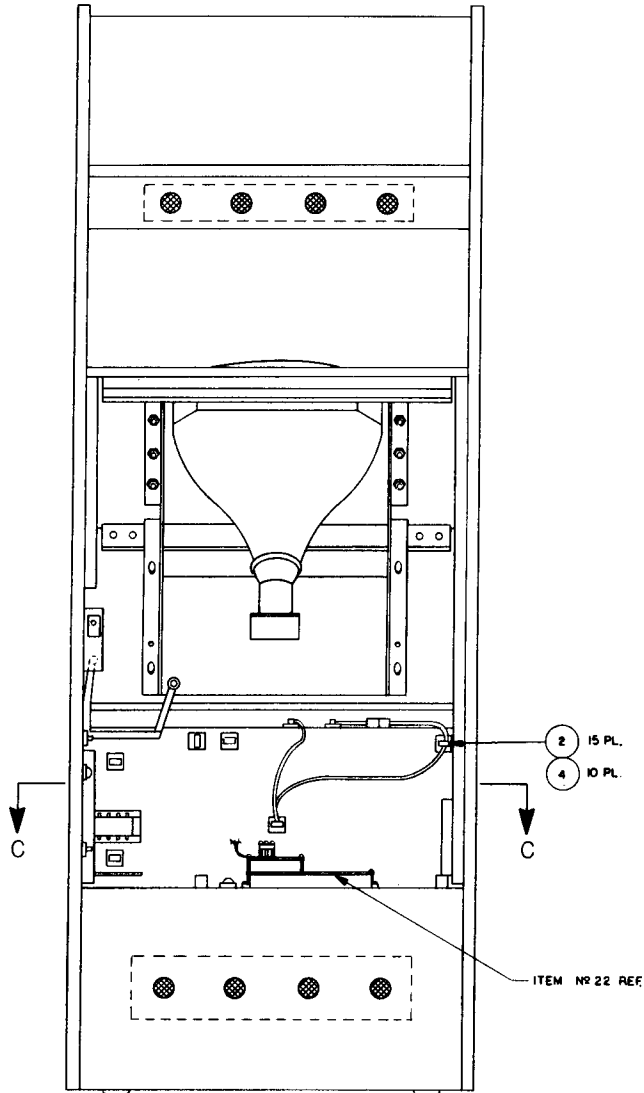

**VIEW B-B**  
(W/ REAR PANEL AND DOOR REMOVED)

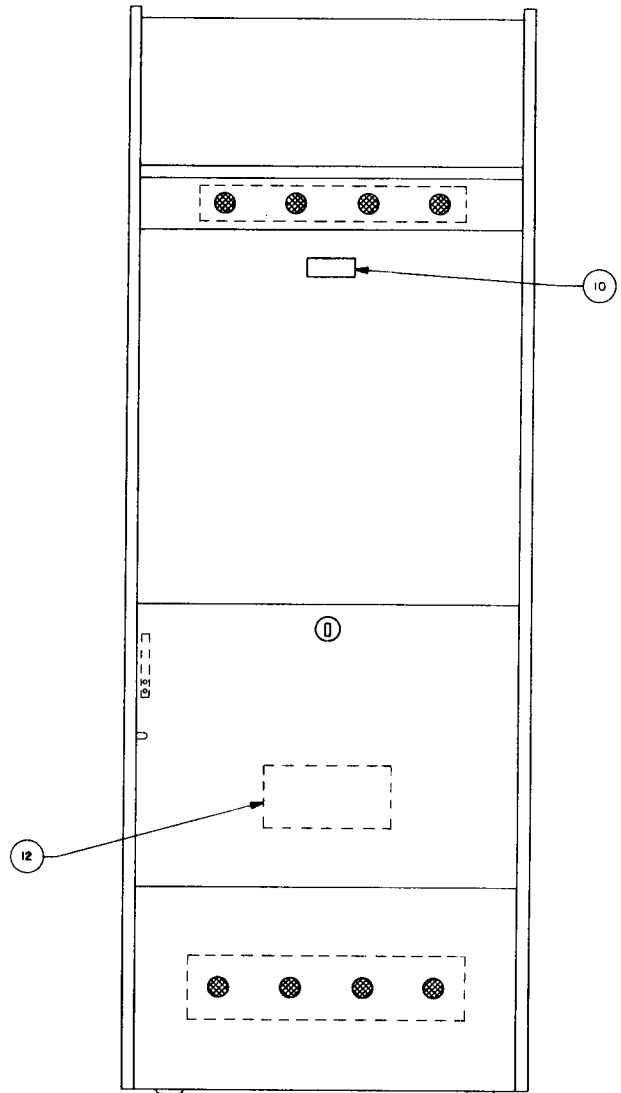

**VIEW B-B**

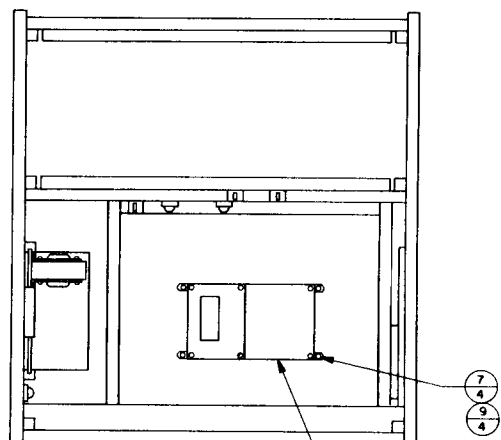

**SECTION C-C**

ITEM NR 22 REF.

TOP ASSEMBLY

DRAWING NUMBER 700-0068

<u>ITEM NO.</u>	<u>PART NO.</u>	<u>QTY REQD.</u>	<u>DESCRIPTION</u>
1	700-0022	1	White Upright Game Assembly
2	800-3187	1	Frogger Assembly Kit

**Top Assembly  
700-0068**

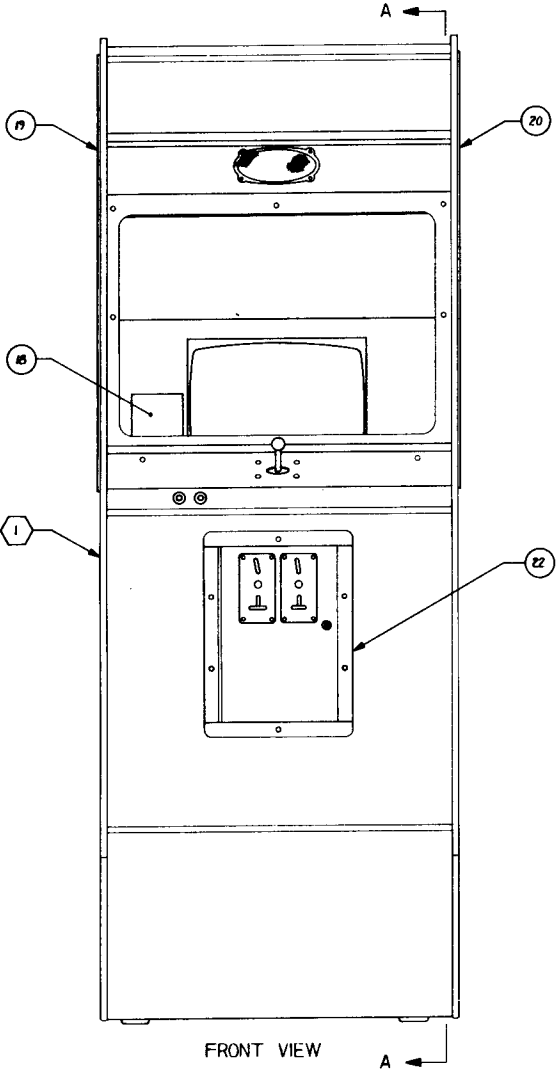

FRONT VIEW

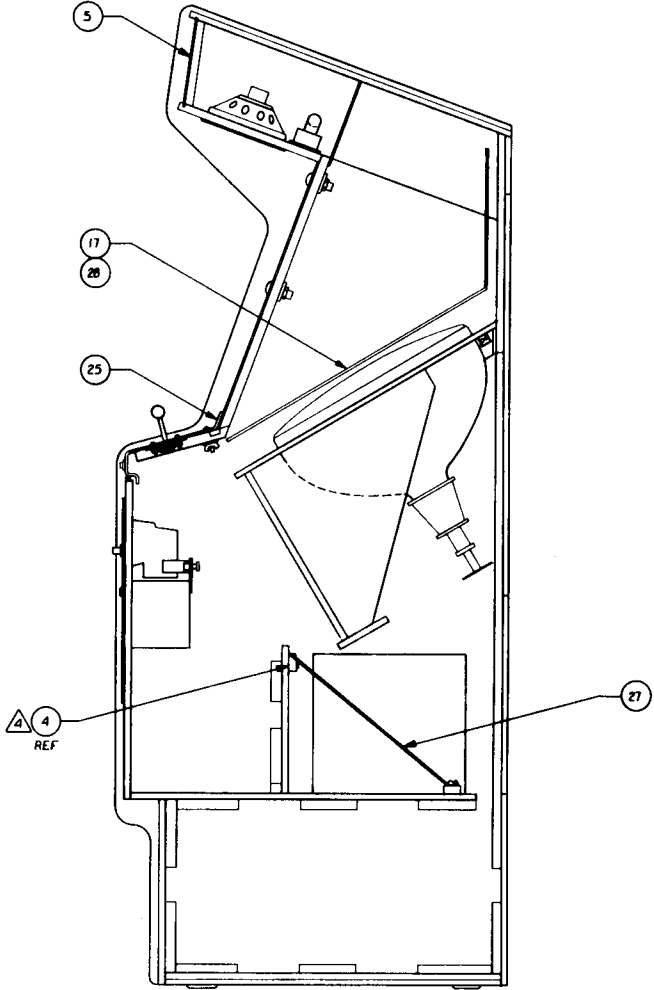

SECTION A-A

# Top Assembly 700-0068

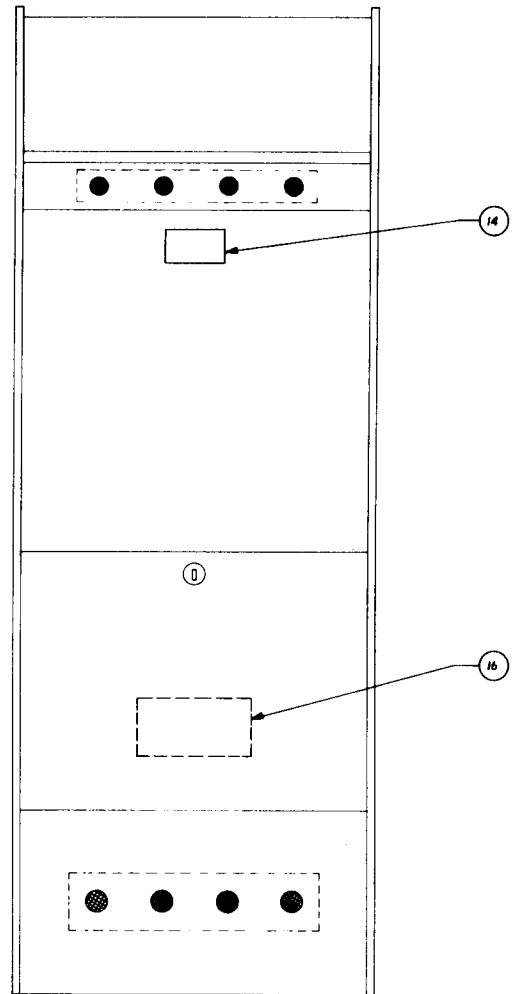
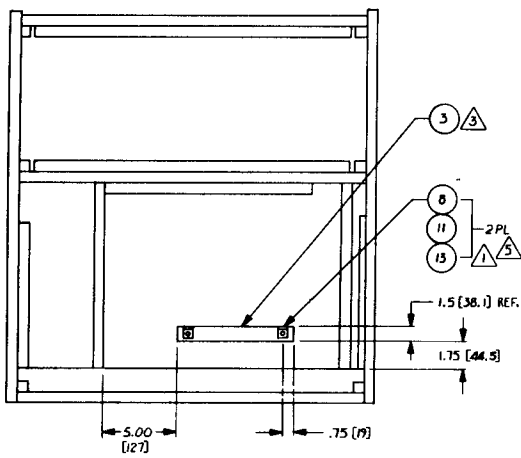
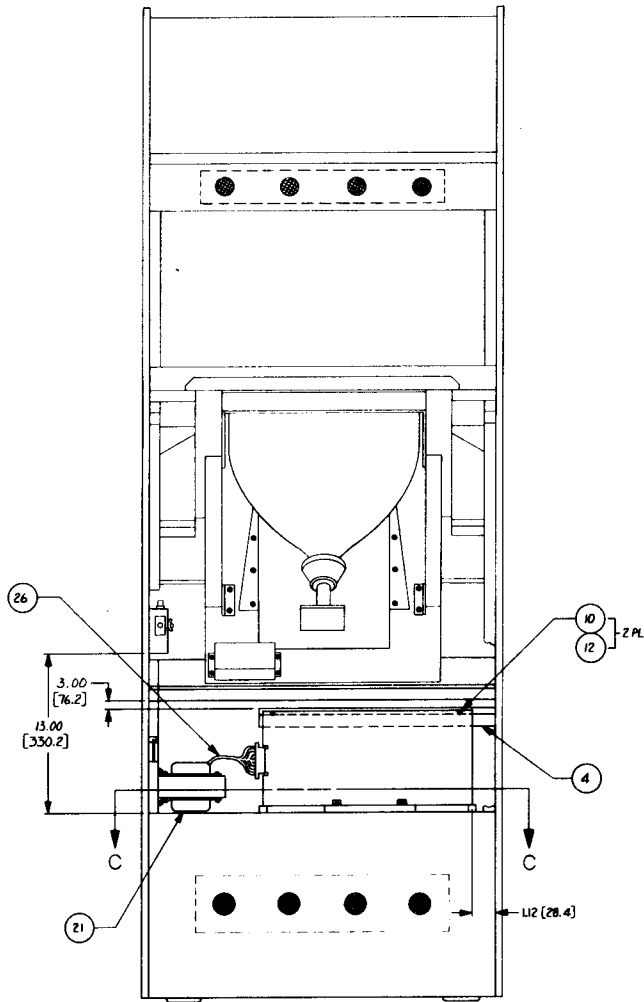

TOP ASSEMBLY

DRAWING NUMBER 700-0069-00

TOP ASSEMBLY

DRAWING NUMBER 700-0069-01

TOP ASSEMBLY

DRAWING NUMBER 700-0069-02

<u>ITEM NO.</u>	<u>PART NO.</u>	<u>QTY REQD.</u>			<u>DESCRIPTION</u>
		-00	-01	-02	
1	130-0001	1	--	--	Speaker, 6 x 9
2	130-0002	1	--	--	Speaker Cover, 6 x 9
3	140-0021	1	--	--	Junction Box Cover
4	140-0049	1	--	--	Basic Upright Cabinet
5	250-0032	1	--	--	Front Bezel
6	250-0034	1	--	--	Spring Retainer
7	250-0038	1	--	--	Moulding Strip
8	250-0048	1	--	--	Clip Switch
9	250-0356	2	--	--	Color Monitor Support Bracket
10	253-0104	1	--	--	Panel Monitor
11	252-0092	1	1	--	PCB Support
12	252-0097	1	1	--	Electronics Mounting Block
13	253-0234	1	--	--	Logo Panel
14	280-0005	10	--	--	Cable Tie
15	280-0004	2	--	--	Hold Down Clip Wire
16	280-0324	2	2	--	Nylon Cable Clamp
17	280-0327	10	--	--	Base Tie Wrap
18	281-0074-20	2	--	--	Flat Head Phillips Wood Screw, #8 x 1½
19	420-0568	1	--	--	FCC Decal
20	420-0646	1	--	--	Frogger Box Decal
21	420-0647	1	--	--	Frogger Manual

TOP ASSEMBLY-Continued

DRAWING NUMBER 700-0069-00

TOP ASSEMBLY-Continued

DRAWING NUMBER 700-0069-01

TOP ASSEMBLY-Continued

DRAWING NUMBER 700-0069-02

<u>ITEM NO.</u>	<u>PART NO.</u>	<u>QTY REQD.</u>			<u>DESCRIPTION</u>
		-00	-01	-02	
22	420-0648	1	--	--	Frogger Interior Graphic
23	420-0652	1	--	--	Game Electronics Decal
24	420-0663	1	--	--	Frogger Left Side Graphic
25	420-0664	1	--	--	Frogger Right Side Graphic
26	800-0130	1	--	--	Power Transformer Assembly
27	800-3181	1	--	--	Control Panel Assembly
28	800-3189	1	--	--	Frogger Master Harness Assembly
29	834-0084	1	--	--	Frogger Game Electronics Assembly
30	281-0014-28	4	--	--	Oval Head Phillips Machine Screw, #8-32x13/4
31	281-0042-06	2	2	--	Pan Head Phillips Screw, #6 x 3/8 S/M
32	281-0044-08	12	2	--	Pan Head Phillips Screw, #8 x 1/2 S/M
33	281-0044-12	2	--	--	Pan Head Phillips Screw, #8 x 3/4 S/M
34	281-0044-20	4	--	--	Pan Head Phillips Screw, #8 x 1 1/4 S/M
35	281-0045-12	2	--	--	Pan Head Phillips Screw, #10 x 3/4 S/M
36	282-0005-20	6	--	--	Carriage Bolt, #10-24 x 1 1/4 Large
37	282-0005-32	8	--	--	Carriage Bolt, #10-24 x 2 Large
38	283-0015-00	4	--	--	Wing Nut, #10-24
39	283-0024-00	4	--	--	Hex Nut, #8-32
40	283-0025-00	11	--	--	Hex Nut, #10-24
41	284-0002-00	2	2	--	Flat Washer, #6
42	284-0004-00	20	2	--	Flat Washer, #8

TOP ASSEMBLY-Continued

DRAWING NUMBER 700-0069-00

TOP ASSEMBLY-Continued

DRAWING NUMBER 700-0069-01

TOP ASSEMBLY-Continued

DRAWING NUMBER 700-0069-02

<u>ITEM NO.</u>	<u>PART NO.</u>	<u>QTY REQD.</u>			<u>DESCRIPTION</u>
		-00	-01	-02	
43	284-0006-00	16	--	--	Flat Washer, #10
44	284-0034-00	16	--	--	Split Lock Washer, #8
45	284-0036-00	11	--	--	Split Lock Washer, #10
46	320-0020	.3ft	--	--	Sealant Foam
47	390-0019	1	--	--	Fluorescent Lamp
48	700-0051	--	1	--	Woodgrain Upright Game Assembly
49	734-0038	--	--	1	Upright Game Assembly
50	800-0029	1	--	--	20" Ground Strap Assembly
51	800-0135	1	--	--	Mechanical Coin Mechanism Assembly
52	800-0136	1	--	--	Speaker Harness Assembly
53	800-0140	1	--	--	19" Color Monitor Assembly
54	800-0145	1	--	--	Junction Box Assembly
55	800-0147	1	--	--	Fluorescent Lamp Assembly
56	800-3184	--	1	1	Frogger Assembly Kit
57	800-0205	1	--	--	Ground Strap Assembly
58	420-0507	1	--	--	Light Baffle
59	420-0030	1	--	--	Caution 115V Decal
60	252-0083	1	--	--	Power Supply Support Block
61	800-3191	1	--	--	Video Interface Harness Assembly
62	253-0241	1	--	--	19" CRT Mask

# Top Assembly 700-0069

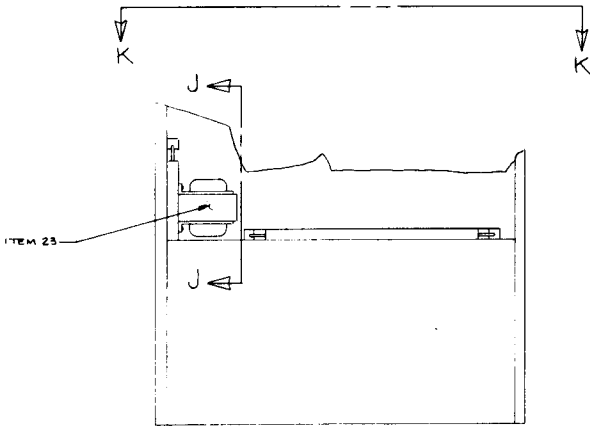

DETAIL H

700-0069-02 PWR SUPPLY AND  
GAIN ELECTRONICS MOUNTING

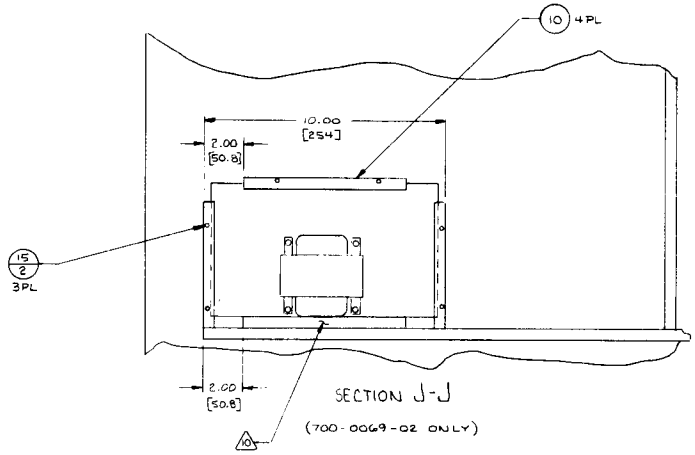

SECTION J-J  
(700-0069-02 ONLY)

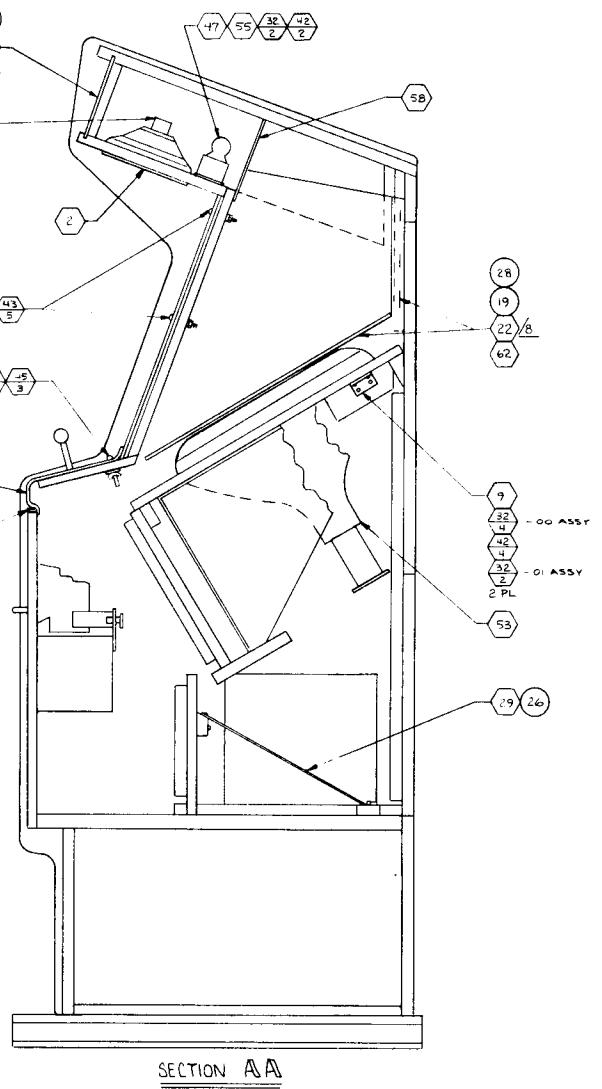
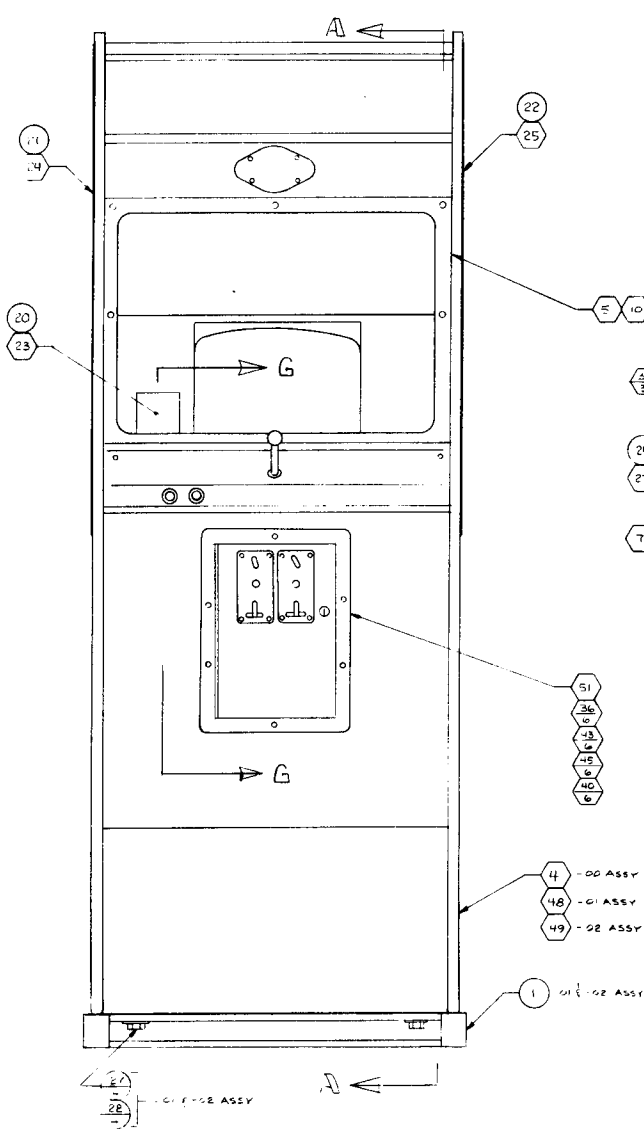

SECTION A-A



# Top Assembly 700-0069

VIEW B-B  
(REAR PANEL AND DOOR REMOVED)  
SEE DETAIL H FOR 700-0069-02  
PART OF THE 700-0069-01 TRIM KIT MTS

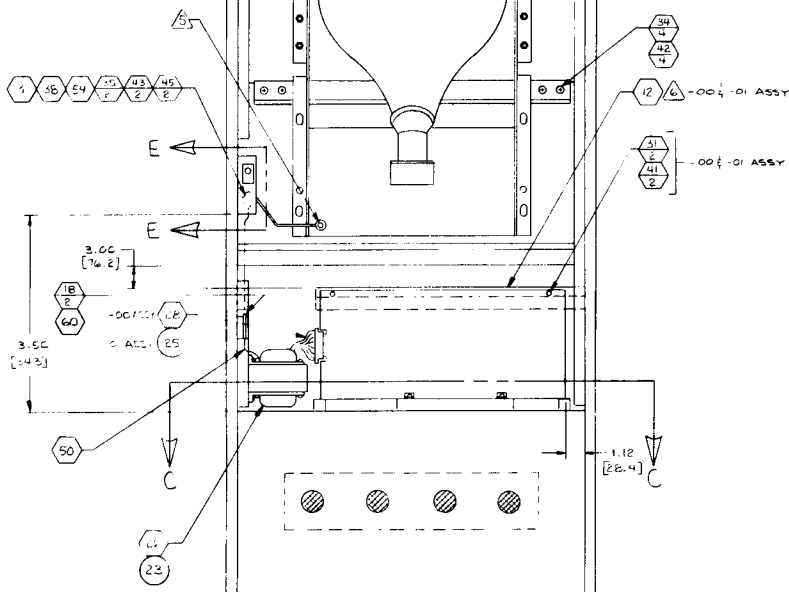
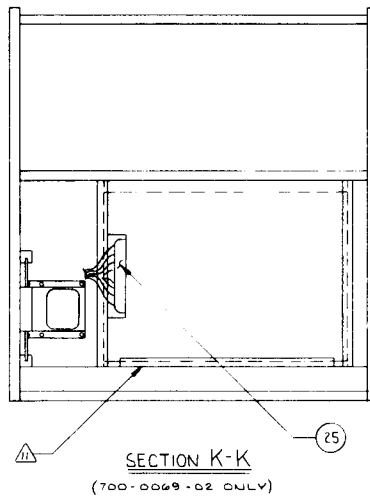
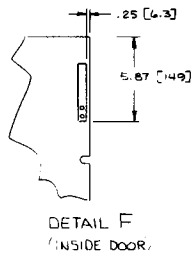
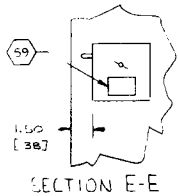

SECTION G-G  
(CONTROL PANEL REMOVED)

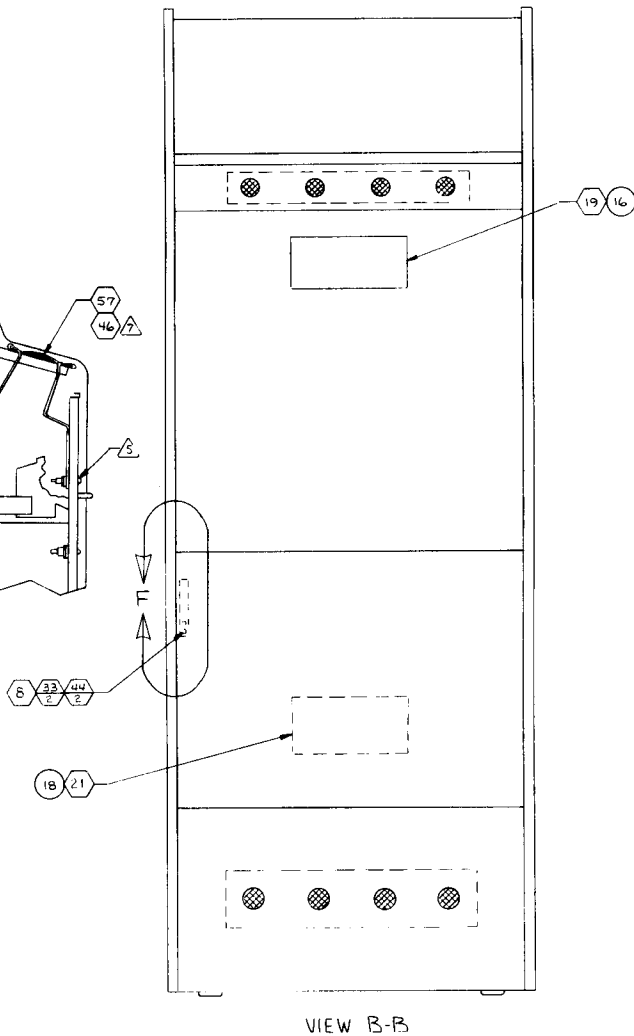
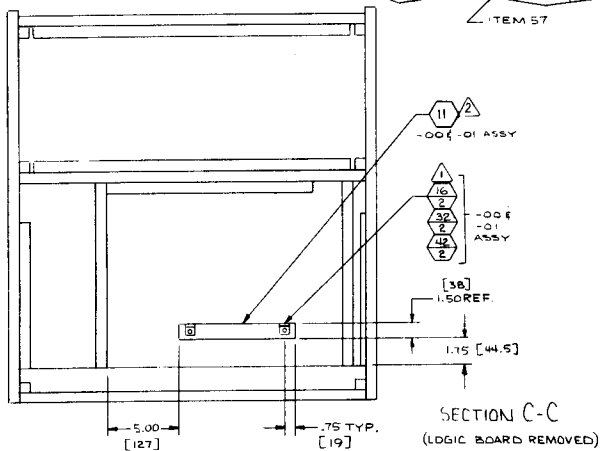
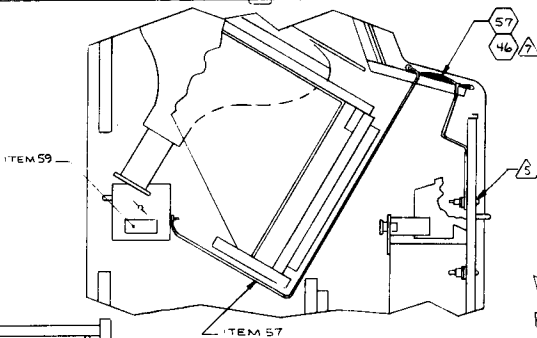

<u>ITEM NO.</u>	<u>PART NO.</u>	<u>QTY REQD.</u>	<u>DESCRIPTION</u>
1	130-0001	1	Speaker, 6 x 9
2	130-0002	1	Speaker Cover
3			
4	140-0021	1	Junction Box Cover
5	140-0049	1	Basic Upright Cabinet
6			
7	250-0032	1	Front Bezel
8	250-0034	1	Spring Retainer
9	250-0038	1	Molding Strip
10	250-0048	1	Clip Switch
11	250-0356	2	Color Monitor Support Bracket
12			
13	252-0083	1	Power Supply Support Block
14			
15	253-0104	1	Panel Monitor
16	253-0234	1	Logo Panel
17	253-0241	1	19" CRT Mask
18			
19	280-0004	2	Hold Down Wire Clip
20	280-0005	10	Cable Tie
21	280-0327	10	Base Tie Wrap
22			
23	281-0014-28	4	Oval Head Phillips Screw #8-32 x 1 3/4"
24	281-0042-12	4	Pan Head Phillips Sheet Metal Screw, #6 x 3/4

<u>ITEM NO.</u>	<u>PART NO.</u>	<u>QTY REQD.</u>	<u>DESCRIPTION</u>
25	281-0044-08	10	Pan Head Phillips Sheet Metal Screw, #8 x $\frac{1}{2}$
26	281-0044-12	2	Pan Head Phillips Sheet Metal Screw, #8 x $\frac{3}{4}$
27	281-0044-20	4	Pan Head Phillips Sheet Metal Screw, #8 x $1\frac{1}{4}$
28	281-0045-12	2	Pan Head Phillips Sheet Metal Screw, #10 x $\frac{3}{4}$
29	281-0074-20	2	Flat Head Phillips Wood Screw, #8 x $1\frac{1}{4}$
30			
31	282-0005-20	6	Carriage Bolt, #10-24 x $1\frac{1}{4}$
32	282-0005-32	8	Carriage Bolt, #10-24 x 2
33			
34	283-0015-00	4	Wing Nut, #10
35	283-0024-00	4	Hex Nut, #8
36	283-0025-00	11	Hex Nut, #10
37			
38	284-0002-00	4	Flat Washer, #6
39	284-0004-00	18	Flat Washer, #8
40	284-0006-00	16	Flat Washer, #10
41	284-0034-00	6	Split Lock Washer, #8
42	284-0036-00	11	Split Lock Washer, #10
43			
44	320-0020	.3ft.	Sealant Foam
45			
46	390-0019	1	Fluorescent Lamp
47			
48	420-0030	1	Caution 115V Decal

<u>ITEM NO.</u>	<u>PART NO.</u>	<u>QTR REQD.</u>	<u>DESCRIPTION</u>
49	420-0507	1	Light Baffle
50	420-0568	1	FCC Decal
51	420-0646	1	Frogger Box Decal
52	420-0647	1	Frogger Manual
53	420-0648	1	Interior Graphic
54	420-0652	1	Game Instruction Decal
55	420-0663	1	Frogger Left Side Graphic
56	420-0664	1	Frogger Right Side Graphic
57			
58	800-0029	1	20" Ground Strap Assembly
59	800-0136	1	Speaker Harness Assembly
60	800-0140	1	19" Color Monitor Assembly
61	800-0145	1	Junction Box Assembly
62	800-0146	1	Isolated Game Power Supply Assembly
63	800-0147	1	Fluorescent Lamp Assembly
64			
65	800-0205	1	Ground Strap Assembly
66			
67	800-3181	1	Control Panel Assembly
68	800-3188	1	Master Harness Assembly
69	800-3191	1	Video Interface Harness Assembly
70	800-3195	1	Coin System Assembly
71			
72	834-0086	1	Game Electronics Assembly

# Top Assembly 700-0070

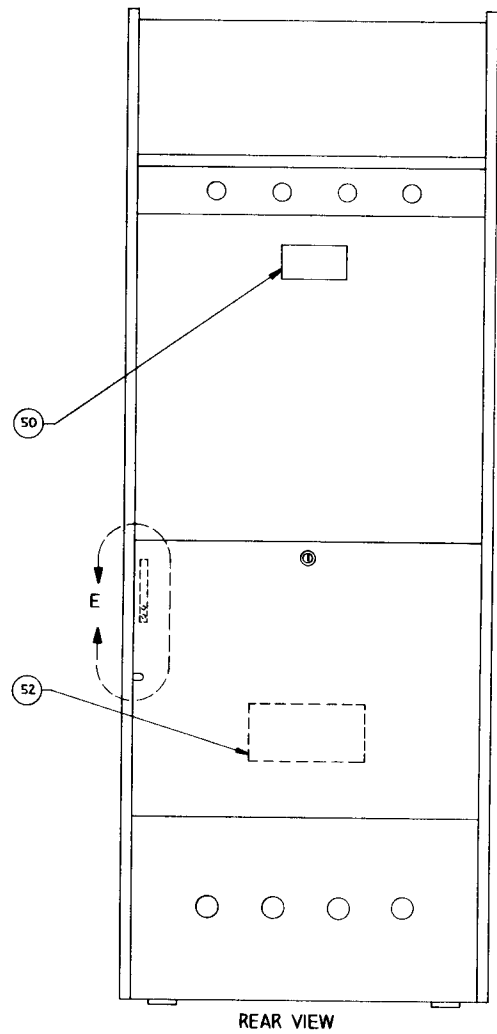
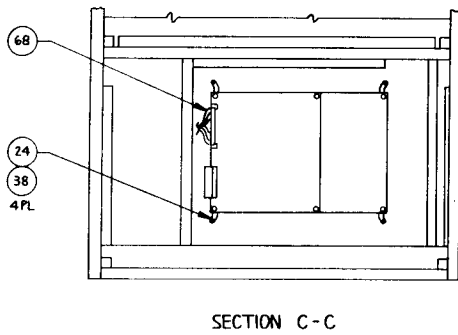
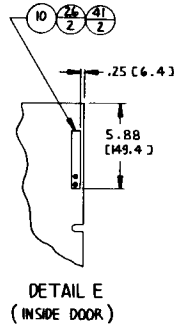
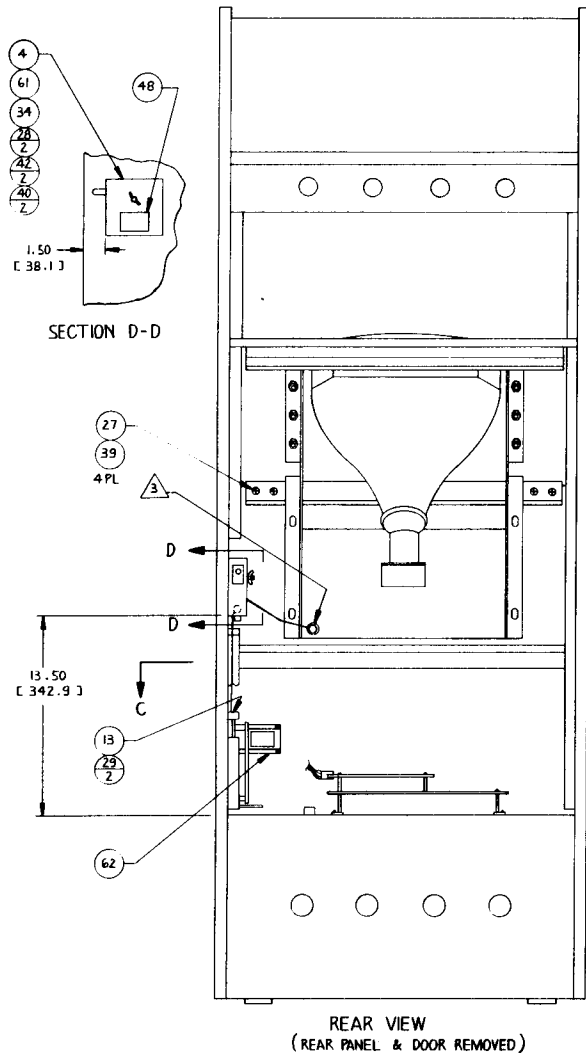

# Top Assembly 700-0070

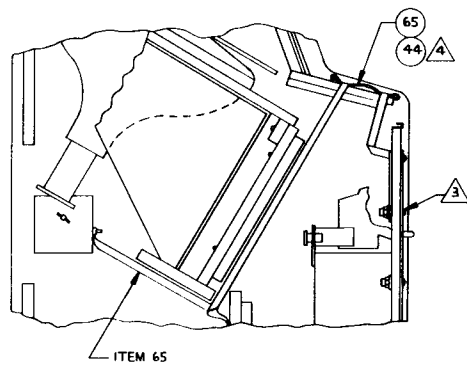
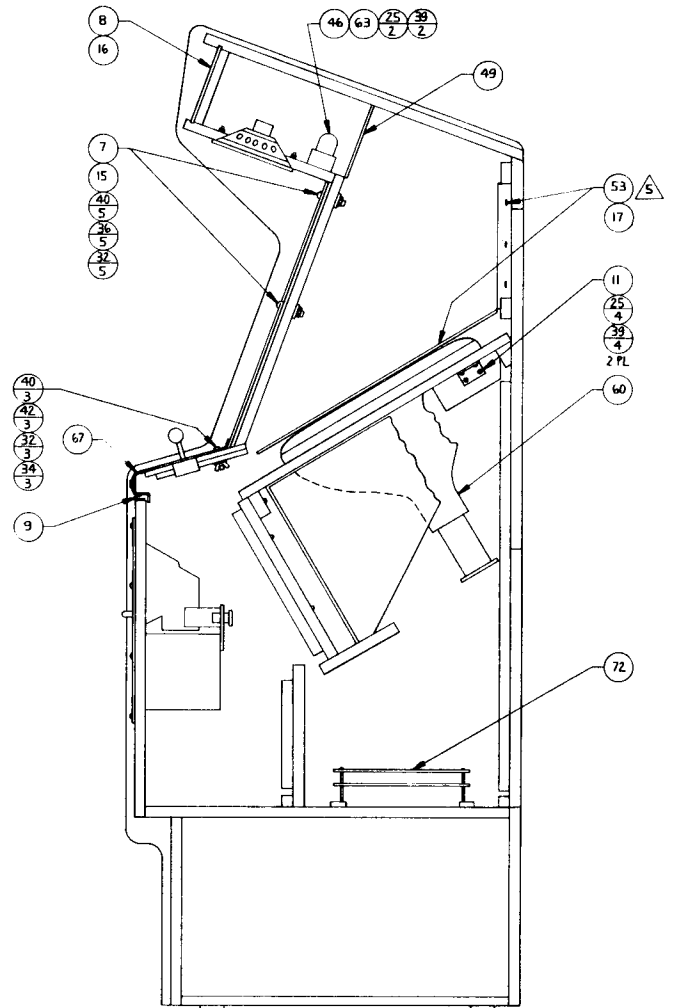
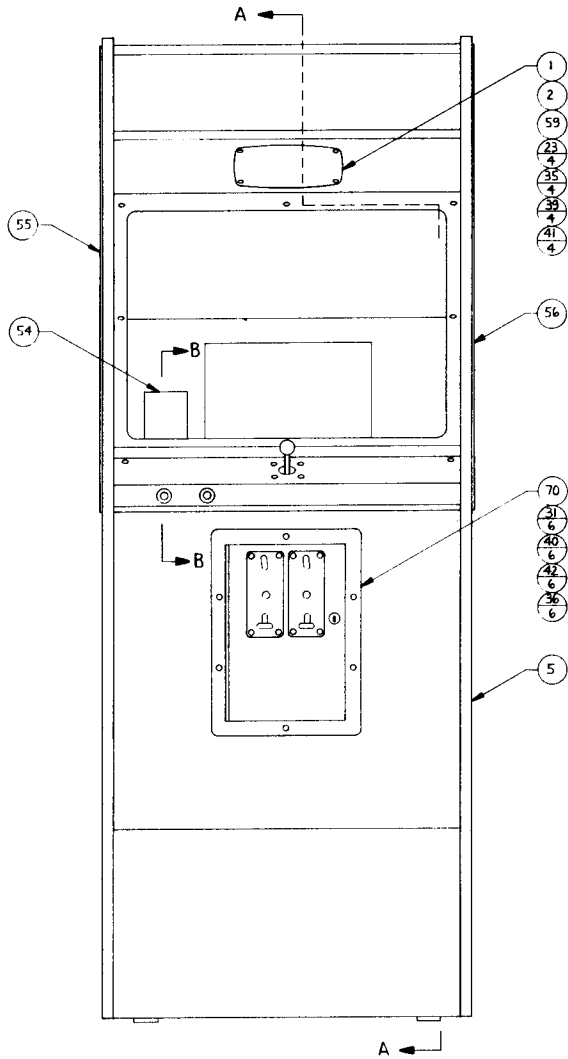

ITEM 65  
SECTION B - B  
(CONTROL PANEL REMOVED)

## TOP ASSEMBLY

DRAWING NUMBER 700-0073

<u>ITEM NO.</u>	<u>PART NO.</u>	<u>QTY. REQ'D</u>	<u>DESCRIPTION</u>
1	130-0020	1	Speaker, 6 X 9, 10W
2	130-0002	1	Speaker Cover
3			
4	140-0021	1	Cover J - Box
5	140-0049	1	Basic Cabinet UPR.
6			
7	250-0032	1	Front Bezel
8	250-0034	1	Spring Retainer
9	250-0038	1	Molding Strip
10	250-0048	1	Clip Switch
11	250-0356	2	Bracket Clr. Mon. Support
12			
13			
14			
15	253-0104	1	Panel Monitor
16	253-0234	1	Panel Logo
17			
18			
19	280-0004	2	Clip Wire Hold Down
20	280-0005	10	Cable Tie
21	280-0327	10	Base Tie Wrap
22			
23	281-0014-28	4	SCR Oval Hd Phil #8-32 X 1 3/4"
24	281-0042-12	4	SCR Phil PN HD #6 X 3/4" SHT MTL
25	281-0044-08	10	SCR Phil PN HD #8 X 1/2" SHT MTL

## TOP ASSEMBLY

DRAWING NUMBER 700-0073

<u>ITEM NO.</u>	<u>PART NO.</u>	<u>QTY. REQ'D</u>	<u>DESCRIPTION</u>
26	281-0044-12	2	SCR Phil PN HD #8 X 3/4" SHT MTL
27	281-0044-20	4	SCR Phil PN HD #8 X 1 1/4" SHT MTL
28	281-0045-12	6	SCR Phil PN HD #10 X 3/4" SHT MTL
29			
30			
31	282-0005-20	6	Bolt Carriage #10-24 X 1 1/4"
32	282-0005-32	8	Bolt Carriage #10-24 X 2"
33			
34	283-0015-00	4	Nut Wing #10
35	283-0024-00	4	Nut Hex #8
36	283-0025-00	11	Nut Hex #10
37			
38	284-0002-00	4	Washer Flt #6
39	284-0004-00	18	Washer Flt #8
40	284-0006-00	20	Washer Flt #10
41	284-0034-00	10	Washer Lock Split #8
42	284-0036-00	15	Washer Lock Split #10
43			
44	320-0020	.3FT	Sealant Foam
45			
46	390-0019	1	Lamp Fluor
47			
48	420-0030	1	Decal Caution 115V
49	420-0507	1	Light Baffle



## TOP ASSEMBLY

DRAWING NUMBER 700-0073

<u>ITEM NO.</u>	<u>PART NO.</u>	<u>QTY. REQ'D</u>	<u>DESCRIPTION</u>
50	420-0568	1	Decal FCC
51	420-0646	1	Box Decal Frogger
52	420-0647	1	Manual Frogger
53	420-0648	1	Graphic Interior
54	420-0652	1	Decal Game Instruction
55			
56			
57			
58	800-0153	1	Assy GND Strap 18"
59	800-0136	1	Assy Speaker Harn
60	800-0140	1	Assy Clr Monitor 19"
61	800-0311	1	Assy J - Box F
62	800-0312	1	Assy Game Pwr Supply Mod.
63	800-0147	1	Assy Fluor Lamp 2
64			
65	800-0205	1	Assy GND Strap
66			
67	800-3181	1	Assy Control Panel Complete
68	800-3188	1	Assy Harn Master Frogger
69	800-3191	1	Assy Harn Video Interface
70	800-3195	1	Assy Coin System
71	211-0055	1	Conn Chassis Wafer Mount
72	834-0086	1	Assy Game Electronics Frogger

# Top Assembly 700-0073

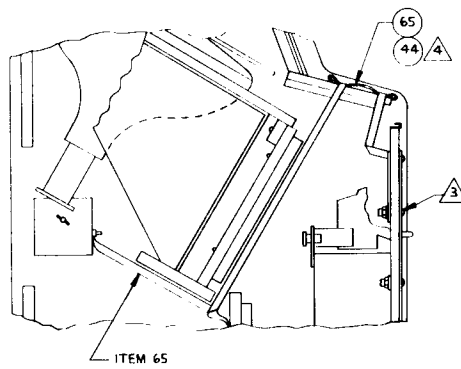
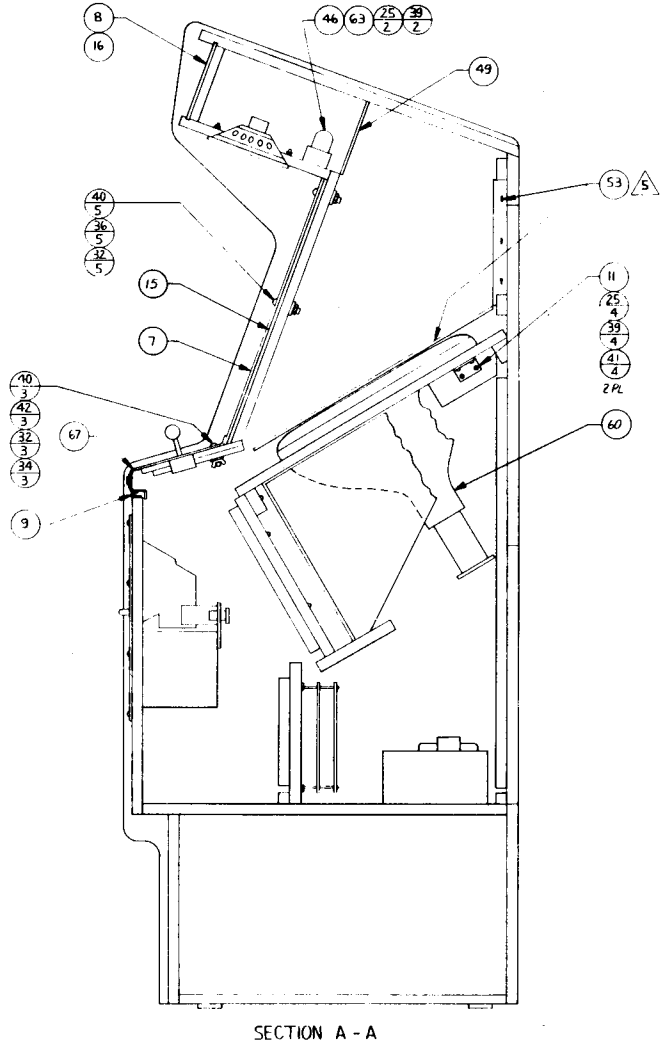
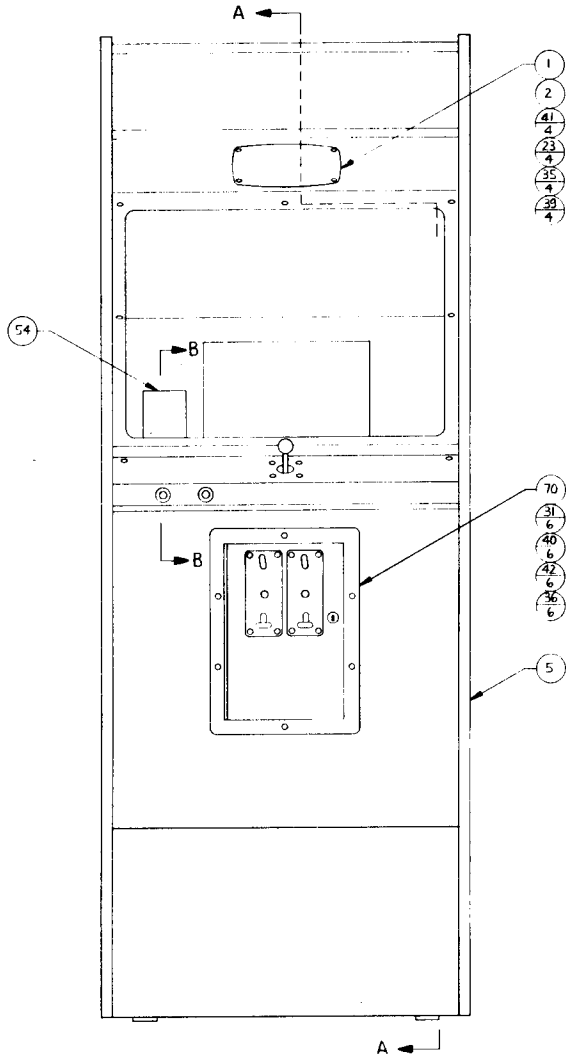

SECTION B - B  
(CONTROL PANEL REMOVED)

# Top Assembly 700-0073

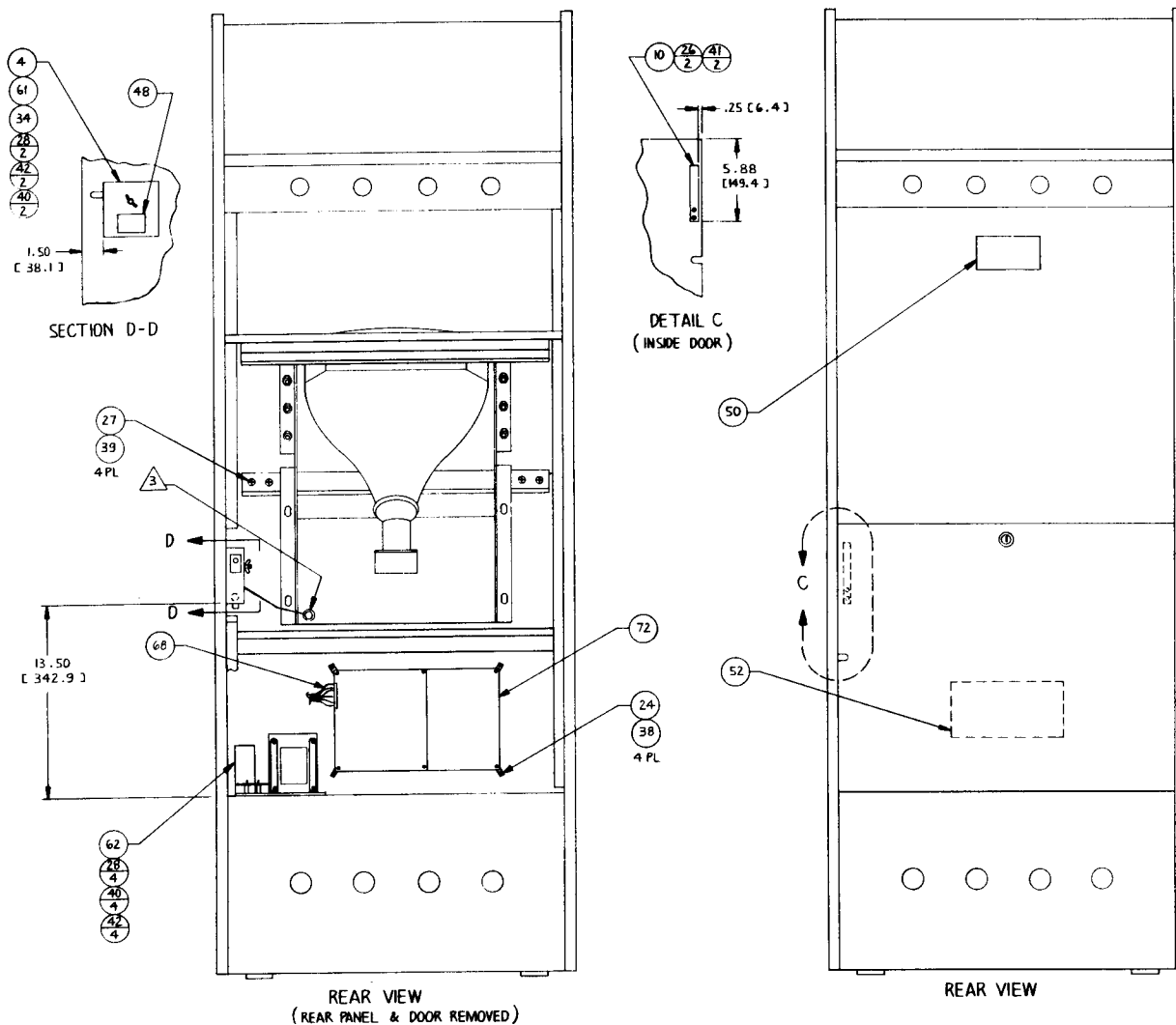

## FROGGER ASSEMBLY KIT

DRAWING NUMBER 800-3182

<u>ITEM NO.</u>	<u>PART NO.</u>	<u>QTY REQD.</u>	<u>DESCRIPTION</u>
1	253-0234	1	Frogger Logo Panel
2	280-0005	15	Cable Tie
3	280-0323	1	Electric Tap Splice
4	280-0327	10	Base Tie Wrap
5	280-0362	2	Electric Crimp Sleeve
6	281-0002-06	2	Pin Head Phillips Machine Screw, #6 x 3/8
7	281-0042-12	4	Pin Head Phillips Screw, S/M, #6 x 3/4
8	283-0022-00	2	Hex Nut, #6
9	284-0002-00	6	Flat Washer, #6
10	420-0568	1	FCC Decal
11	420-0646	1	Frogger Box Decal
12	420-0647	1	Frogger Manual
13	420-0648	1	Frogger Interior Graphic
14	420-0652	1	Game Instructions Decal
15	420-0663	1	Frogger Woodgrain Left Side Graphic
16	420-0664	1	Frogger Woodgrain Right Side Graphic
17	800-3181	1	Frogger Control Panel Assembly
18	800-3188	1	Master Harness Assembly
19	800-3190	1	Volume Control Bracket Assembly
20	800-3191	1	Video Interface Harness Assembly
21	800-3192	1	Volume Control Assembly

## FROGGER ASSEMBLY KIT-Continued

DRAWING NUMBER 800-3182

<u>ITEM NO.</u>	<u>PART NO.</u>	<u>QTY REQD.</u>	<u>DESCRIPTION</u>
22	834-0086	1	Frogger Game Electronics Assembly
23	253-0241	1	19" CRT Mask

## FROGGER ASSEMBLY KIT

DRAWING NUMBER 800-3183

<u>ITEM NO.</u>	<u>PART NO.</u>	<u>QTY REQD.</u>	<u>DESCRIPTION</u>
1	140-0058	1	SEGA Game Pallet
2			
3	211-0038	2	Female Quick Connector, 3/16
4	211-0041	13	Connector Pin AMP
5			
6	211-0044	1	2-Pin Connector Cap AMP
7	211-0046	1	6-Pin Connector Cap AMP
8	211-0047	1	12-Pin Connector Cap AMP
9			
10	253-0234	1	Frogger Logo Panel
11	280-0005	15	Cable Tie
12	280-0327	10	Base Tie Wrap
13			
14	281-0042-12	4	Pin Head Phillips Screw, #6 x 3/4 S/M
15			
16	284-0002-00	4	Flat Washer, #6
17	420-0568	1	FCC Decal
18	420-0646	1	Frogger Box Decal
19	420-0647	1	Frogger Manual
20	420-0648	1	Frogger Interior Graphic
21	420-0652	1	Game Instructions Decal
22	420-0663	1	Frogger Woodgrain Left Side Graphic
23	420-0664	1	Frogger Woodgrain Right Side Graphic

<u>ITEM NO.</u>	<u>PART NO.</u>	<u>QTY REQD.</u>	<u>DESCRIPTION</u>
24	800-0146	1	Game Power Supply Assembly
25	800-3181	1	Control Panel Assembly
26	800-3188	1	Master Harness Assembly
27	800-3192	1	Volume Control Assembly
28	834-0086	1	Game Electronics Assembly
29	282-0019-32	4	Hex Head Bolt 3/8-16 x 2
30	284-0029-00	4	Fender Washer, 3/8
31	253-0241	1	19" CRT Mask

## FROGGER ASSEMBLY KIT

DRAWING NUMBER 800-3184

<u>ITEM NO.</u>	<u>PART NO.</u>	<u>QTY REQD.</u>	<u>DESCRIPTION</u>
1	140-0058	1	Game Pallet
2	211-0017	1	Quick Female Connector $\frac{1}{4}$
3	211-0047	1	12-Pin Cap Connector Amp
4	211-0038	2	Female Quick Connector 3/16
5	211-0041	23	Pin Amp Connector
6			
7	211-0044	1	2-Pin Cap Connector Amp
8	211-0046	1	6-Pin Cap Connector Amp
9	211-0060	1	3-Pin Cap Connector Amp
10	252-0083	4	Power Supply Support Block
11	253-0234	1	Logo Panel
12	280-0005	15	Cable Tie
13	280-0323	2	Electro Tap Splice Amp
14	280-0327	10	Base Tie Wrap
15	281-0074-20	6	Flat Head Phillips Wood Screw, #8 x $1\frac{1}{4}$
16	420-0568	1	FCC Decal
17	420-0646	1	Frogger Box Decal
18	420-0647	1	Frogger Manual
19	420-0648	1	Interior Graphic
20	420-0652	1	Game Instruction Decal
21	420-0663	1	Frogger Woodgrain Left Side Graphic
22	420-0664	1	Frogger Woodgrain Right Side Graphic
23	800-0130	1	Power Transformer Assembly
24	800-3181	1	Control Panel Assembly



<u>ITEM NO.</u>	<u>PART NO.</u>	<u>QTY REQD.</u>	<u>DESCRIPTION</u>
25	800-3189	1	Frogger Master Harness Assembly
26	834-0084	1	Frogger Game Electronics Assembly
27	284-0029-00	4	Fender Washer 3/8"
28	282-0019-32	4	Hex Head Bolt, 3/8-16 x 2
29	514-0001	1	2 Amp Slow Blow Fuse

## FROGGER ASSEMBLY KIT

DRAWING NUMBER 800-3187

<u>ITEM NO.</u>	<u>PART NO.</u>	<u>QTY REQD.</u>	<u>DESCRIPTION</u>
1	211-0041	4	Pin Connector Amp
2	211-0044	2	2-Pin Cap Connector Amp
3	252-0092	1	PCB Support
4	252-0097	1	Electronics Mounting Block
5	253-0234	1	Logo Panel
6	280-0005	15	Cable Tie
7	280-0323	2	Electro Tap Splice
8	280-0324	2	Cable Clamp
9	280-0327	10	Base Tie Wrap
10	281-0042-06	2	Pan Head Phillips Screw, #6 x 3/8 S/M
11	281-0044-08	2	Pan Head Phillips Screw, #8 x 1/2 S/M
12	284-0002-00	2	Flat Washer, #6
13	284-0004-00	2	Flat Washer, #8
14	420-0568	1	FCC Decal
15	420-0646	1	Frogger Box Decal
16	420-0647	1	Frogger Manual
17	420-0648	1	Interior Graphic
18	420-0652	1	Game Instruction Decal
19	420-0661	1	Frogger Left Side Graphic
20	420-0662	1	Frogger Right Side Graphic
21	800-0130	1	Power Transformer Assembly
22	800-0135	1	Mechanical Coin Mechanism Assembly
23	800-3191	1	Video Interface Harness Assembly
24	800-0159	1	Monitor Harness Assembly

<u>ITEM NO.</u>	<u>PART NO.</u>	<u>QTY REQD.</u>	<u>DESCRIPTION</u>
25	800-3181	1	Control Panel Assembly
26	800-3189	1	Frogger Master Harness Assembly
27	834-0084	1	Frogger Game Electronics Assembly
28	253-0241	1	19" CRT Mask

## CONTROL PANEL ASSEMBLY

DRAWING NUMBER 800-3181

<u>ITEM NO.</u>	<u>PART NO.</u>	<u>QTY REQD.</u>	<u>DESCRIPTION</u>
1	510-0059	1	4-Way Long Shaft Joystick
2		4	Carriage Bolt, #10-24 x .75 Long
3		4	Hex Nut, #10-24
4		4	Lock Washer, #10
5		4	Flat Washer, #10
6	280-0329	2	Hex Nut, Pal, 1/2-13
7	240-0111	2	Blue Button Plunger
8	253-0031	4	Switch Spacer
9	510-0023	2	Switch Assembly
10	253-0235	1	Control Panel Graphic
11	280-0005	4	Cable Tie
12	280-0327	2	Base Tie Wrap
13	250-0508	1	Subpanel Metal Weldment
14	800-0303	1	Control Panel Harness Assembly

# Control Panel Assembly 800-3181

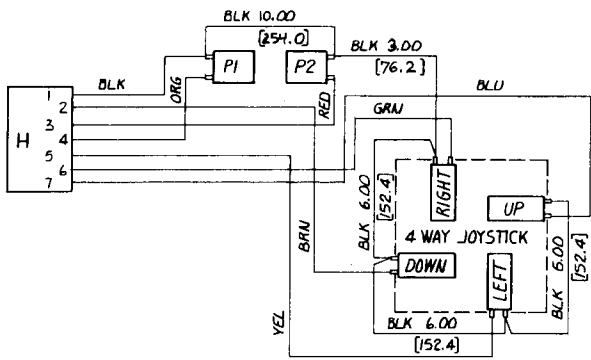
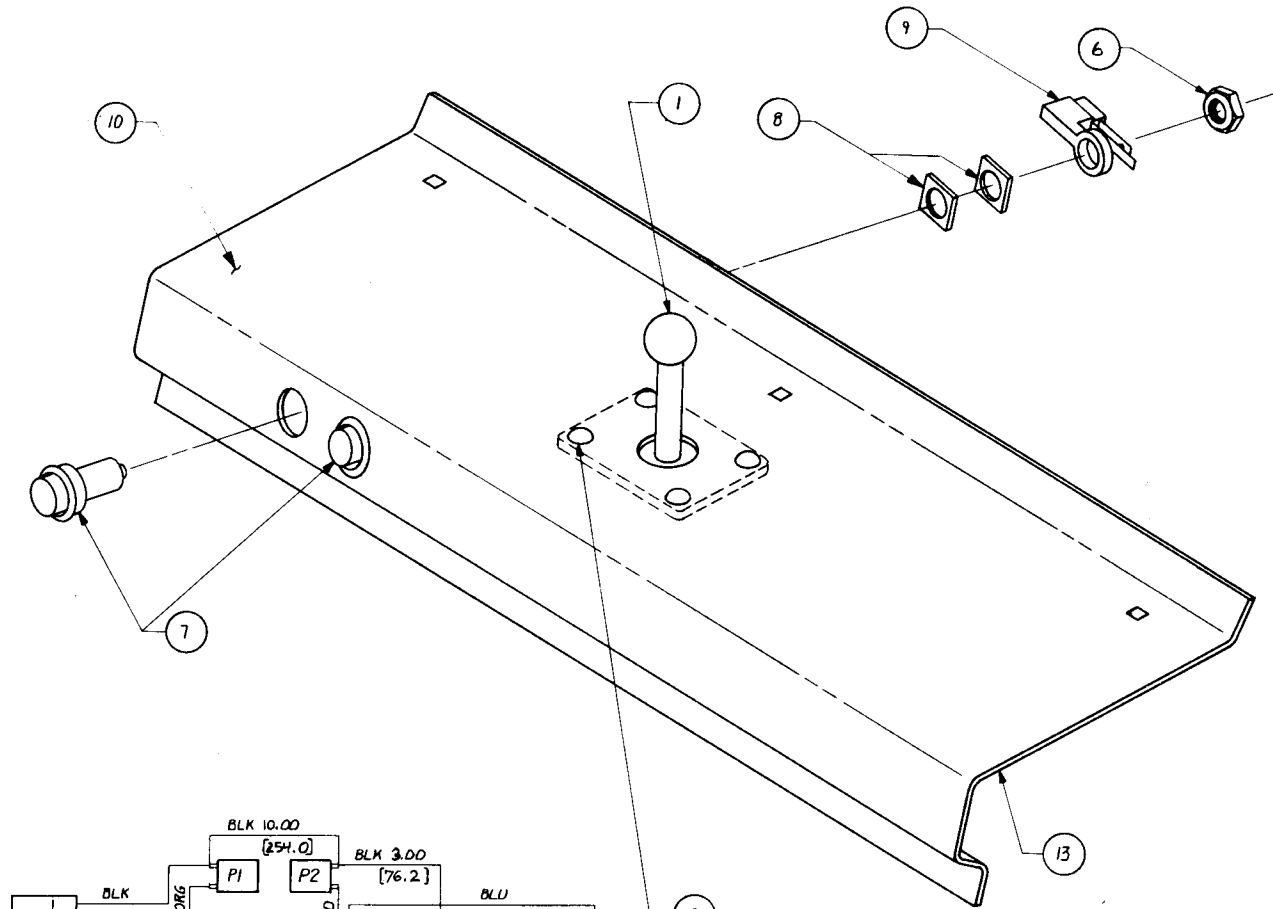

**WIRING DIAGRAM**   
 SWITCHES SHOWN AS VIEWED  
 FROM WIRING SIDE OF PANEL

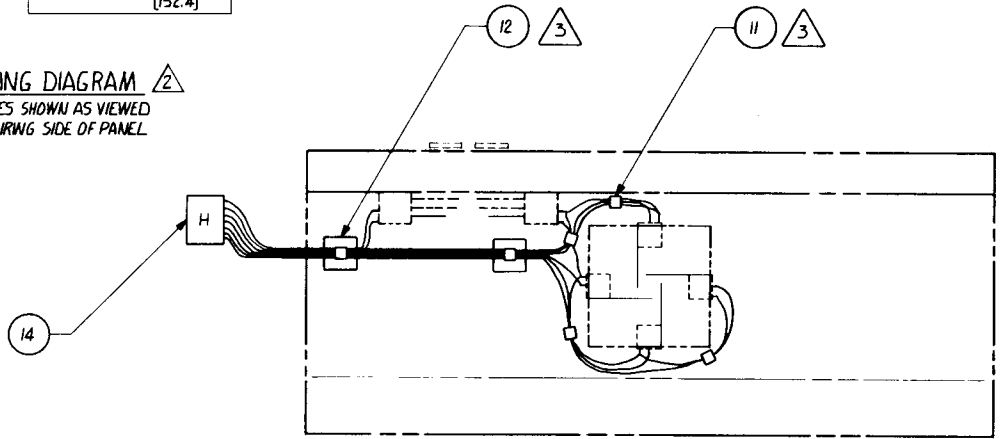

REAR VIEW

VOLUME CONTROL BLOCK ASSEMBLY

DRAWING NUMBER 800-3031

<u>ITEM NO.</u>	<u>PART NO.</u>	<u>QTY REQD.</u>	<u>DESCRIPTION</u>
1	250-0068	1	Switch Bracket
2	475-0007	1	10K Panel Mount Pot
3	510-0051	2	Push Button Slide Switch
4	240-0001	1	Volume Control Knob
5	420-0395	1	Volume Control Decal
6		4	Aluminum Rivet 1/8"

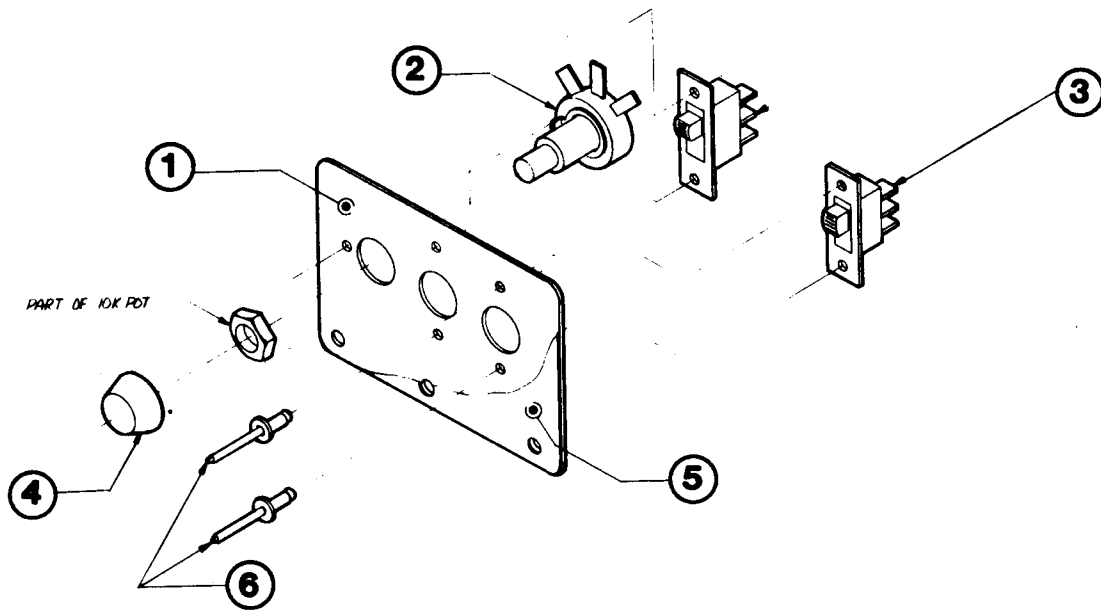

VOLUME CONTROL ASSEMBLY

DRAWING NUMBER 800-3192

<u>ITEM NO.</u>	<u>PART NO.</u>	<u>QTY REQD.</u>	<u>DESCRIPTION</u>
1	475-0034	1	200 ohm Panel Mount Pot
2	600-0090	1	6-Pin Volume Socket and Cable Assembly

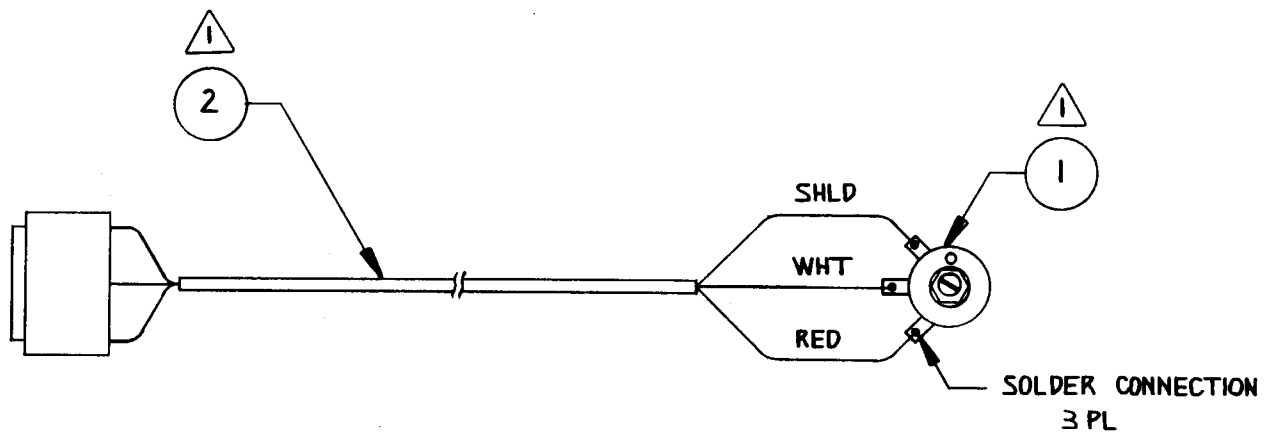

## LINEAR POWER SUPPLY ASSEMBLY

DRAWING NUMBER 800-0146

<u>ITEM NO.</u>	<u>PART NO.</u>	<u>QTY REQD.</u>	<u>DESCRIPTION</u>
1	211-0005	6	Crimp Lock Connector
2	211-0017	1	Quick Connector $\frac{1}{4}$ "
3	211-0042	7	Connector Socket AMP
4	211-0059	1	3-Pin Plug Connector AMP
5	212-0016	1	10-Pin Female Connector
6	250-0433	1	Isolated Power Supply Heat Sink
7	250-0434	1	Isolated Power Supply Chassis
8	280-0005	4	Cable Tie
9	280-0014	6	Stand Off Clips
10	280-0117	1	Rivet Tab
11	560-0054	1	Isolated Transformer
12	800-0128	1	Game Power Supply PC Assembly
13		4	Pop Rivet 3/16
14		8	Pin Head Machine Screw, #4-40 x $\frac{1}{4}$
15		6	Sheet Metal Screw, #6 x $\frac{1}{2}$
16		4	Flat Washer, #10
17		6	Transistor Insulator
18	211-0043	2	2-Pin Connector Plug AMP
19			
20	600-0079	1ft.	2 Condition Zip Cord
21	280-0359	2	Electric Crimp Sleeve



# Linear Power Supply Assembly 800-0146

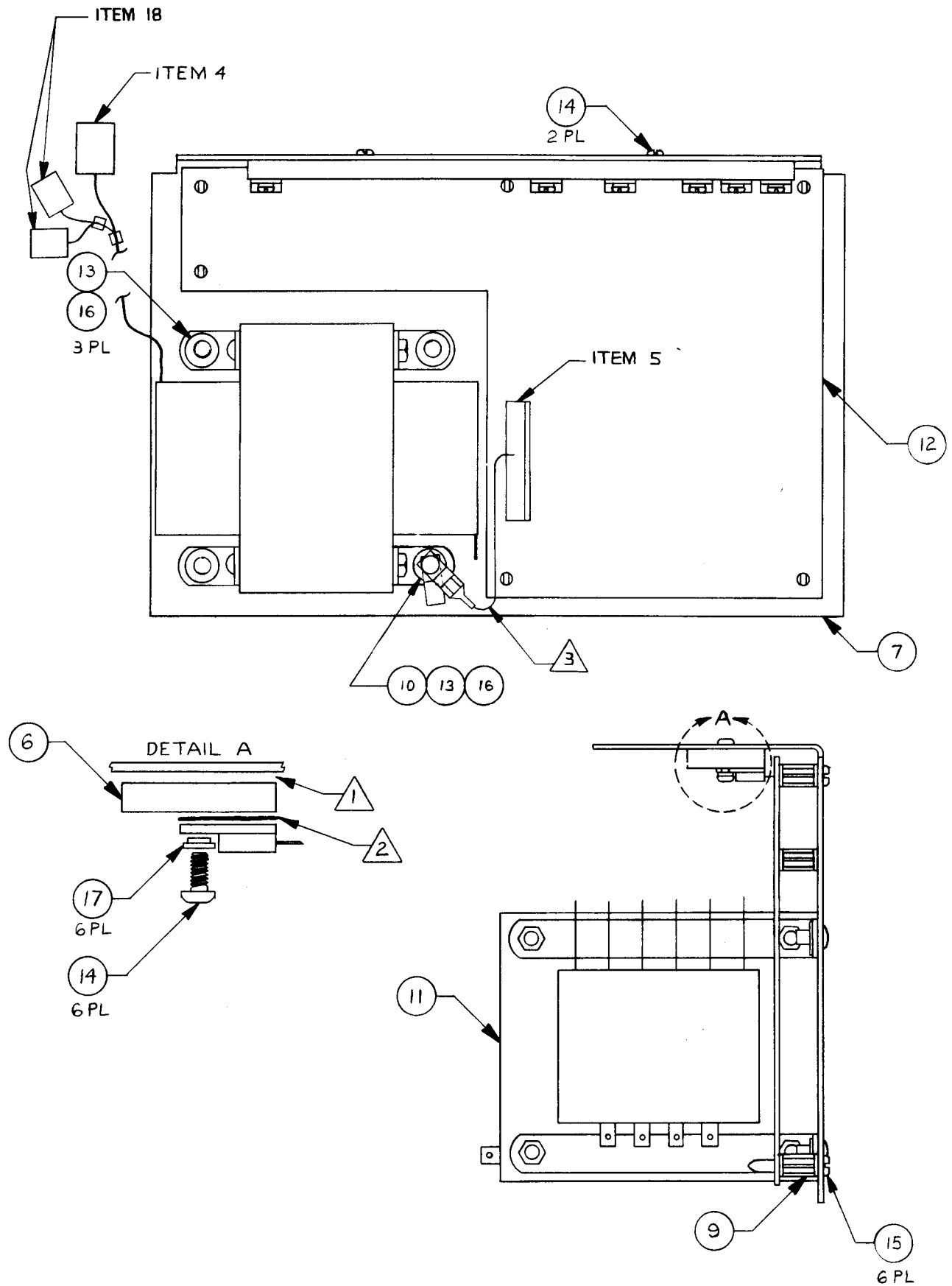

# Linear Power Supply Assembly 800-0146

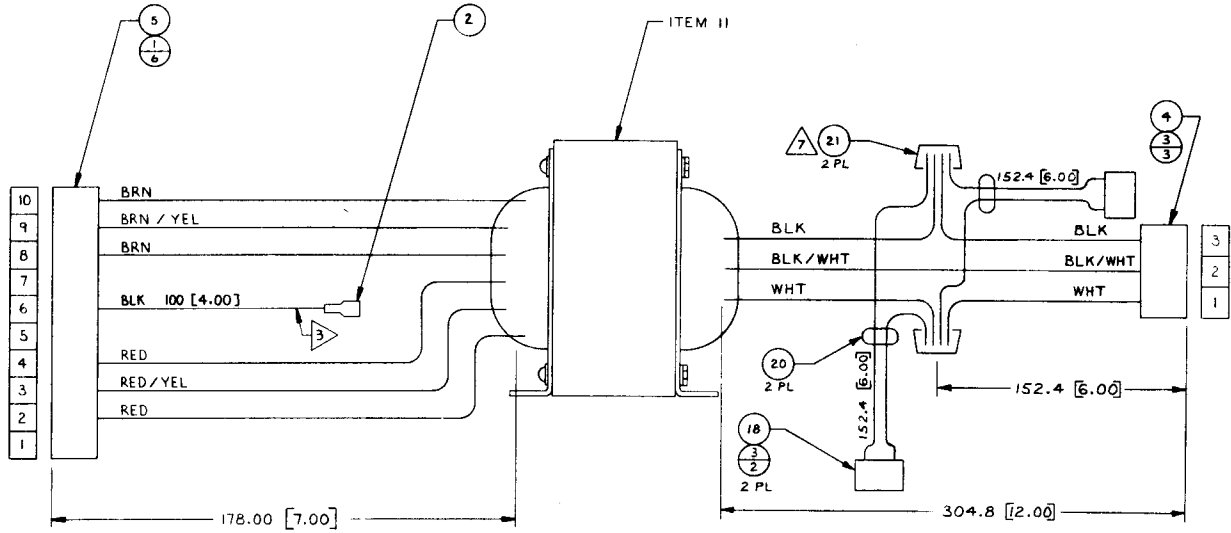

## GAME POWER SUPPLY PC ASSEMBLY

DRAWING NUMBER 800-0128

<u>ITEM NO.</u>	<u>PART NO.</u>	<u>QTY REQD.</u>	<u>DESCRIPTION</u>	<u>REF DES.</u>
1	150-0088	9	Electrolytic Capacitor, 10uf, 25V RDL	C2,C3,C7, C10,C11,C14, C16,C19,C20
2	150-0092	2	Electrolytic Capacitor, 100uf, 25V RDL	C15,C26
3	150-0095	1	Electrolytic Capacitor, 3300uf, 16V RDL	C24
4	150-0096	1	Electrolytic Capacitor, 6800uf, 16V RDL	C25
5	150-0097	2	Electrolytic Capacitor, 4700uf, 25V RDL	C22,C23
6				
7	151-0002	1	Ceramic Capacitor, 100pf, 50V	C9
8	151-0007	1	Ceramic Capacitor,.005uf,100V	C5
9	151-0008	1	Ceramic Capacitor,.001uf, 50V	C17
10	151-0011	2	Ceramic Capacitor, .01uf, 50V	C4,C33
11	151-0012	12	Ceramic Capacitor, .1uf, 50V	C6,C8,C13, C18,C21, C26-C32
12	170-0202	1	PC Board	
13	151-0021	1	Ceramic Capacitor, 20pf, 50V	C12
14	313-0001	1	IC LM723 DIP	U1

<u>ITEM NO.</u>	<u>PART NO.</u>	<u>QTY REQD.</u>	<u>DESCRIPTION</u>	<u>REF DES.</u>
15	313-0037	1	IC TL081	U2
16	313-0015	1	IC LM320T-12	U5
17	313-0023	1	IC LM320T-5	U4
18	471-0011	1	Resistor, 10 ohm, $\frac{1}{2}$ W 5%	R19
19	471-0101	1	Resistor, 100 ohm, $\frac{1}{2}$ W 5%	R2
20	471-0102	6	Resistor, 1K ohm, $\frac{1}{2}$ W 5%	R6,R7,R11, R21,R22,R24
21	471-0103	2	Resistor, 10K ohm, $\frac{1}{2}$ W 5%	R8,R27
22	471-0122	1	Resistor, 1.2K ohm, $\frac{1}{2}$ W 5%	R3
23	471-0221	1	Resistor, 220 ohm, $\frac{1}{2}$ W 5%	R33
24	471-0222	3	Resistor, 2.2K ohm, $\frac{1}{2}$ W 5%	R13,R16,R26
25	471-0272	1	Resistor, 2.7K ohm, $\frac{1}{2}$ W 5%	R30
26	471-0332	1	Resistor, 3.3K ohm, $\frac{1}{2}$ W 5%	R4
27	471-0471	1	Resistor, 470 ohm, $\frac{1}{2}$ W 5%	R9
28	471-0472	2	Resistor, 4.7K ohm, $\frac{1}{2}$ W 5%	R1,R29
29	471-0473	1	Resistor, 47K ohm, $\frac{1}{2}$ W 5%	R10
30	473-00R1	1	Resistor, .1 ohm, 5W 3%	R32
31	473-00R2	3	Resistor, .2 ohm, 3W 5%	R12,R14,R15
32	475-0004	2	Pot 1K Car PCMTV	R5,R23
33	481-0004	8	Diode MR501	D1-D8
34				
35	481-0006	3	Diode IN914/IN4148	D9-D11
36	482-0006	3	Transistor 2N4403	Q1-Q3

<u>ITEM NO.</u>	<u>PART NO.</u>	<u>QTY REQD.</u>	<u>DESCRIPTION</u>	<u>REF DES.</u>
37	482-0014	2	Transistor 2N4401	Q4, Q5
38	482-0019	2	Transistor TIP120	Q6, Q8
39	482-0100	2	Transistor TIP125	Q7, Q9
40	514-0002	2	3A Norm Fuse	F3, F4
41	514-0003	8	Fuse Mounting Clip	
42	514-0006	1	1.5A Norm Fuse	F2
43	212-0004	2	4-Pin Male Connector	
44	212-0021	2	10-Pin Male Connector	
45	514-0055	1	5A Norm Fuse	F1
46	471-0220	1	Resistor, 22 ohm, $\frac{1}{2}$ W 5%	R17
47	471-0223	2	Resistor, 22K ohm, $\frac{1}{2}$ W 5%	R20, R25
48	471-0681	1	Resistor, 680 ohm, $\frac{1}{2}$ W 5%	R18
49	471-0104	1	Resistor, 100K ohm, $\frac{1}{2}$ W 5%	R28

# Game Power Supply PC Assembly 800-0128

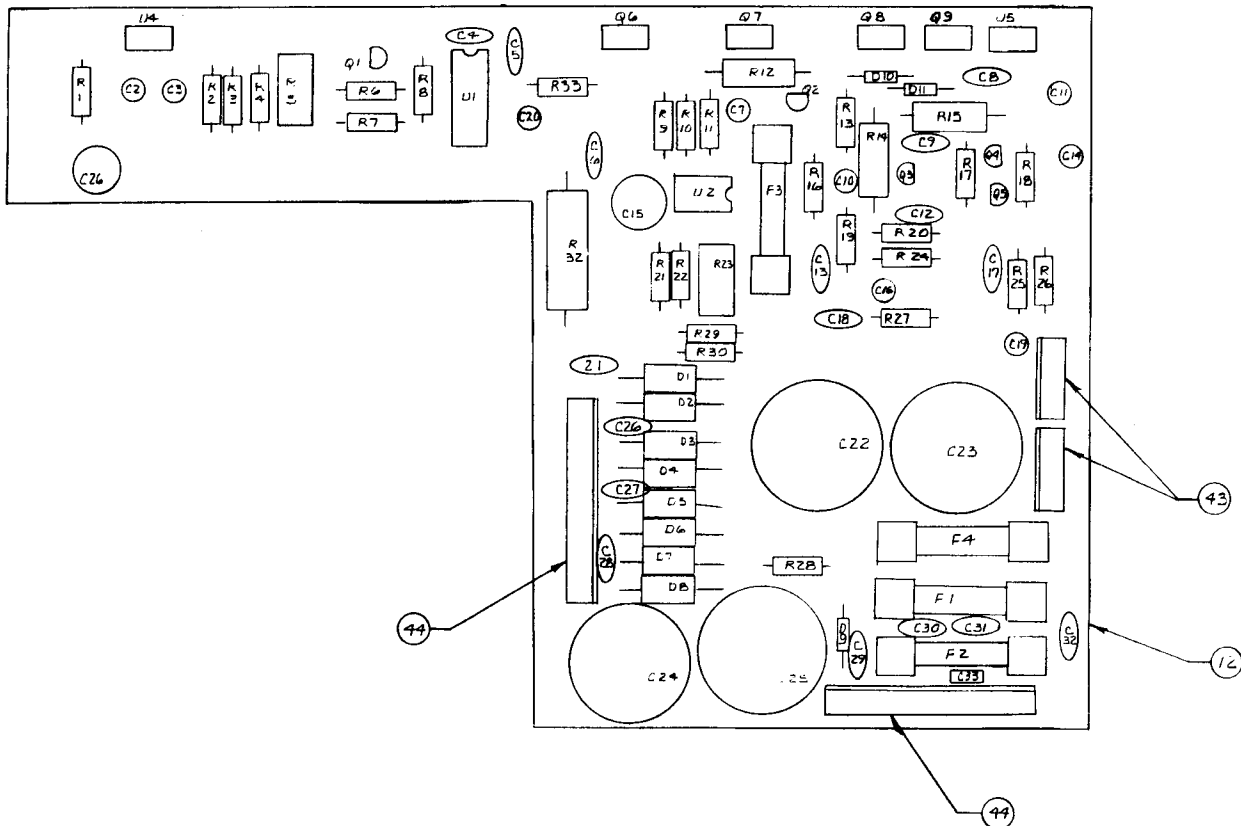

## FROGGER GAME ELECTRONICS ASSEMBLY

DRAWING NUMBER 834-0086

<u>ITEM NO.</u>	<u>PART NO.</u>	<u>QTY REQD.</u>	<u>DESCRIPTION</u>
1	280-0257	10	Spring Washer
2	280-0373	3	Pan Head Phillips Screw, M3-4
3	280-0260	2	Hex Nut, M3 ISO
4	280-0265	5	Pan Head Phillips Screw, M3-6
5	280-0267	8	Spacer Tube, .75L
6	280-0268	3	Spacer Tube, 1.00L
7	280-0269	5	Plastic Polycarbonate Washer, 3.3-8 x 0.8
8	280-0270	2	Pan Head Phillips Screw, M3 x 50 ISO
9	280-0271	4	Pan Head Phillips Screw, M3 x 30 ISO
10	280-0272	4	PCB Mounting Foot
11	600-0091	1	34-Pin Flat Cable and Plug Assembly
12	834-0068	1	Main Logic Board Assembly
13	834-0069	1	Sub Logic Board Assembly

# Frogger Game Electronics 834-0086

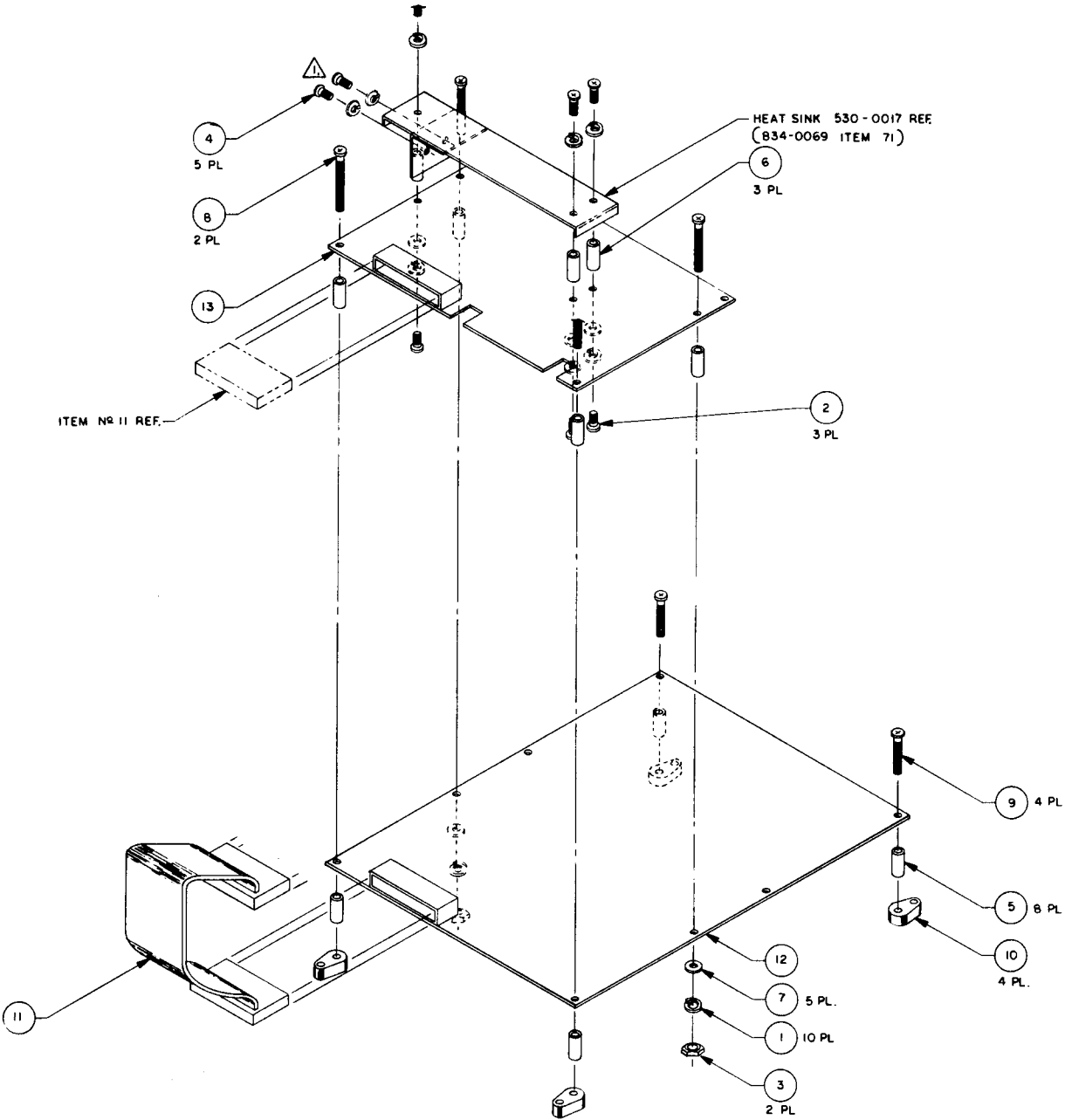



## SUB LOGIC BOARD ASSEMBLY

DRAWING NUMBER 834-0069

<u>ITEM NO.</u>	<u>PART NO.</u>	<u>QTY REQD.</u>	<u>DESCRIPTION</u>	<u>REF DES.</u>
1	150-0092	1	Electrolytic Capacitor, 100mf, 25V, U Type	
2	150-0126	1	Electrolytic Capacitor, 220mf, 10V, U Type	
3	150-0197	1	Electrolytic Capacitor, 100mf, 16V, U Type	
4	150-0200	1	Electrolytic Capacitor, 47mf, 16V, U Type	
5				
6	151-0002	1	Ceramic Capacitor, 100pf, 50V	
7	151-0042	1	Ceramic Capacitor, 470pf, 50V	
8	151-0060	34	Ceramic Capacitor, .1mf, 16V AX	
9				
10	152-0031	2	Film Capacitor, .1mf, 50V	
11	152-0033	1	Film Capacitor, .01mf, 50V	
12	152-0038	3	Film Capacitor, .047mf, 35V	
13				
14	153-0028	3	Tantalum Capacitor, .22mf, 35V	
15	153-0030	1	Tantalum Capacitor, 6.8mf, 16V	
16	153-0046	1	Tantalum Capacitor, .15mf, 35V	
17				
18	170-0237	1	Printed Board	
19				

## SUB LOGIC BOARD ASSEMBLY- Continued

DRAWING NUMBER 834-0069

<u>ITEM NO.</u>	<u>PART NO.</u>	<u>QTY REQD.</u>	<u>DESCRIPTION</u>	<u>REF DES.</u>
20	212-0105	1	2-Pin Connector Plug	2P
21	212-0106	1	6-Pin Connector Plug	6P
22	212-0107	1	34-Pin Socket	(Flat Cable)
23				
24	213-0001	3	24-Pin Dual Inline Socket	IC32,33,34
25	213-0005	2	40-Pin Dual Inline Socket	IC26, 35
26				
27	230-0035	1	14.318 MHZ Crystal	
28				
29	313-0004	1	IC LM741	IC1
30				
31	314-0005	1	IC 7493	IC6
32	314-0012	5	IC 7408	IC3,10,27,28, 29
33	314-0015	3	IC 7404	IC14,25,39
34	314-0018	2	IC 74LS00	IC12,41
35	314-0058	1	IC 74LS08	IC5
36	314-0061	1	IC 74LS42	IC4
37	314-0062	4	IC 74LS74	IC11,18,19, 20
38	314-0066	2	IC 74LS27	IC9,37
39	314-0068	2	IC 74LS32	IC21,36
40	314-0078	1	IC 74LS02	IC8

## SUB LOGIC BOARD ASSEMBLY-Continued

DRAWING NUMBER 834-0069

<u>ITEM NO.</u>	<u>PART NO.</u>	<u>QTY REQD.</u>	<u>DESCRIPTION</u>	<u>REF DES.</u>
41	314-0099	1	IC 74LS245	IC13
42	314-0142	1	IC 74LS90	IC17
43	314-0195	2	IC 74LS93	IC15,16
44				
45	315-0031	2	IC Z80	IC26
46	315-0045	3	IC CD4066	IC22,23,24
47	315-0046	2	IC 2114	IC30,31
48	315-0050	3	IC 2716	IC32,33,34
49	315-0057	1	IC AY-3-8910	IC35
50	315-0085	1	IC M51516	IC2
51	315-0089	2	IC 8255	IC7,40
52				
53	470-0102	13	Resistor, 1K ohm, $\frac{1}{4}$ W 5%	
54	470-0103	2	Resistor, 10K ohm, $\frac{1}{2}$ W 5%	
55	470-0221	17	Resistor, 220 ohm $\frac{1}{4}$ W 5%	
56	470-0331	1	Resistor, 330 ohm, $\frac{1}{4}$ W 5%	
57	470-0472	1	Resistor, 4.7K ohm, $\frac{1}{4}$ W 5%	
58	470-0512	6	Resistor, 5.1K ohm, $\frac{1}{4}$ W 5%	
59	470-0562	1	Resistor, 5.6K ohm, $\frac{1}{4}$ W 5%	
60	470-0821	2	Resistor, 820 ohm, $\frac{1}{4}$ W 5%	
61				
62	477-0035	1	Resistor Pack, 4 x 1K ohm, 1/8W w/c	
63	477-0039	2	Resistor Pack, 8 x 1K ohm, 1/8W w/c	

## SUB LOGIC BOARD ASSEMBLY-Continued

DRAWING NUMBER 834-0069

<u>ITEM NO.</u>	<u>PART NO.</u>	<u>QTY REQD.</u>	<u>DESCRIPTION</u>	<u>REF DES.</u>
64				
65	482-0160	2	Transistor 2SC1815	
66	482-0230	1	Transistor 2SD361	
67	482-0231	2	Transistor 2SC2320	
68				
69	510-0043	1	6-Position Dip Switch	
70				
71	530-0017	1	Heat Sink	

## MAIN LOGIC BOARD ASSEMBLY

DRAWING NUMBER 834-0068

<u>ITEM NO.</u>	<u>PART NO.</u>	<u>QTY REQD.</u>	<u>DESCRIPTION</u>	<u>REF DES.</u>
1	150-0126	1	Electrolytic Capacitor, 220mf, 10V U Type	
2	150-0159	1	Electrolytic Capacitor, 220mf, 16V U Type	
3	150-0199	1	Electrolytic Capacitor, 10mf, 16V U Type	
4				
5	151-0002	1	Ceramic Capacitor, 100pf, 50V	
6	151-0042	2	Ceramic Capacitor, 470pf, 50V	
7	151-0060	57	Ceramic Capacitor, .1mf, 16V	
8				
9	170-0236	1	PC Board	
10				
11	212-0107	1	34-Pin Socket	(Flat Cable)
12				
13	213-0001	6	24-Pin Dual Inline Socket	IC5,6,7,8, 101,102
14	213-0005	1	40-Pin Dual Inline Socket	IC2
15				
16	230-0073	1	18.432 MHZ Crystal	
17				
18	314-0006	1	IC 7474	IC96
19	314-0018	4	IC 74LS00	IC30,34,35, 67

## MAIN LOGIC BOARD ASSEMBLY-Continued

DRAWING NUMBER 834-0068

<u>ITEM NO.</u>	<u>PART NO.</u>	<u>QTY REQD.</u>	<u>DESCRIPTION</u>	<u>REF DES.</u>
20	314-0019	1	IC 74LS04	IC66
21	314-0022	3	IC 74161	IC71,82,95
22	314-0058	3	IC 74LS08	IC45,46,65
23	314-0059	1	IC 74LS10	IC68
24	314-0060	3	IC 74LS20	IC32,36,78
25	314-0062	4	IC 74LS74	IC26,79,80 92
26	314-0068	1	IC 74LS32	IC44
27	314-0070	7	IC 74LS86	IC47,48,70, 81,83,94,100
28	314-0073	3	IC 74LS175	IC43,54,55
29	314-0075	1	IC 74LS393	IC69
30	314-0076	9	IC 74LS157	IC62,63,64, 89,90,97,98, 99,106
31	314-0078	3	IC 74LS02	IC23,33,53
32	314-0087	2	IC 74LS139	IC28,41
33	314-0092	2	IC 2816	IC74,75
34	314-0097	3	IC 74LS161	IC37,49,84
35	314-0098	4	IC 74LS194	IC91,103, 104,105
36	314-0100	3	IC 74LS273	IC24,87,88
37	314-0101	2	IC 74LS283	IC76,77

## MAIN LOGIC BOARD ASSEMBLY-Continued

DRAWING NUMBER 834-0068

<u>ITEM NO.</u>	<u>PART NO.</u>	<u>QTY REQD.</u>	<u>DESCRIPTION()</u>	<u>REF DES.</u>
38	314-0102	7	IC 74LS367	IC3,4,14,27, 38,39,52
39	314-0103	1	IC 74LS368	IC73
40	314-0104	5	IC 74LS138	IC15,16,17, 18,29
41	314-0108	1	IC 74LS107	IC72
42	314-0119	1	IC 74LS377	IC61
43	314-0143	1	IC 74LS259	IC42
44	314-0204	1	IC 74LS126	IC93
45	314-0099	1	IC 74LS245	IC1
46	315-0050	2	IC 2716	IC101,102
47	315-0080	1	IC 6331	IC25
48	315-0083	3	IC 2732	IC5,6,7,8
49	315-0104	4	IC 2114-2	IC50,51,85, 86
50	315-0105	4	IC 2114-3	IC20,21,22, 23
51	315-0216	5	IC 74S201	IC56,57,58, 59,60
52	315-0041	1	IC Z80A	IC2
53	470-0101	1	Resistor, 100 ohm, $\pm$ W 5%	
54	470-0102	12	Resistor, 1K ohm, $\pm$ W 5%	
55	470-0103	1	Resistor, 10K ohm, $\pm$ W 5%	

## MAIN LOGIC BOARD ASSEMBLY-Continued

DRAWING NUMBER 834-0068

<u>ITEM NO.</u>	<u>PART NO.</u>	<u>QTY REQD.</u>	<u>DESCRIPTION</u>	<u>REF DES.</u>
56	470-0221	4	Resistor, 220 ohm, $\frac{1}{4}$ W 5%	
57	470-0331	2	Resistor, 330 ohm, $\frac{1}{4}$ W 5%	
58	470-0471	9	Resistor, 470 ohm, $\frac{1}{4}$ W 5%	
59				
60	481-0089	1	Diode 10D1	
61	481-0164	1	Diode 1S1588	
62				
63	482-0229	1	Transistor 2SA697	
64	482-0231	1	Transistor 2SC2320	



## MECHANICAL COIN MECHANISM ASSEMBLY

DRAWING NUMBER 800-0135

<u>ITEM NO.</u>	<u>PART NO.</u>	<u>QTY REQD.</u>	<u>DESCRIPTION</u>
1	250-0285	1	Modified Frame Cash Door
2	220-0157	2	Anticheat Coin Mechanism
3	220-0008	1	Digital Counter
4	220-0035	1	Fort Lock IR
5			
6			
7			
8	420-0038	1	Important Note Decal
9	280-0004	3	Wire Hold-down Clip
10	280-0323	2	Electro Tap Splice Amp
11	800-3135	1	Coin Mechanism Service Assembly
12		1	Flat Washer #8
13		7	Tamper-proof Screw #8-32 x $\frac{1}{2}$ "
14		9	Split Lock Washer #8
15		9	Hex Nut, #8-32
16		1	Tamper-proof Screw #8-32 x 1"
17		2	Sheet Metal Screw #6 x $\frac{3}{8}$ "
18		2	Sheet Metal Screw #6 x $\frac{1}{2}$ "

# Mechanical Coin Mechanism Assembly 800-0135

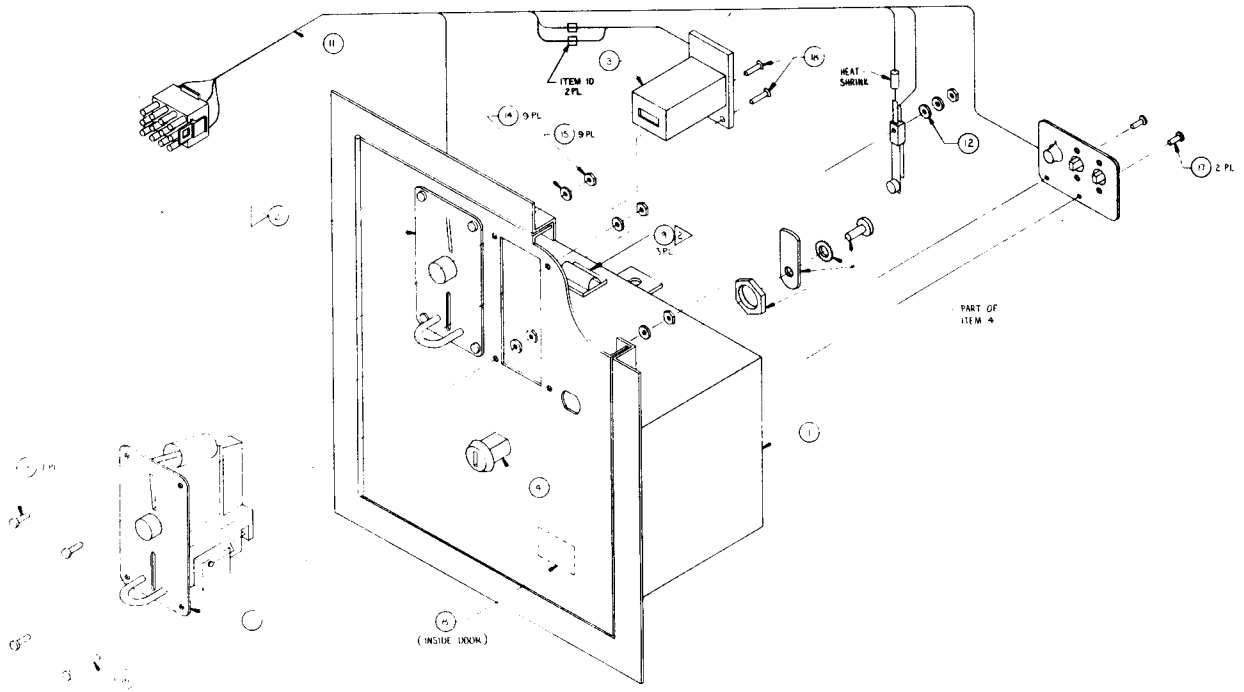

## POWER TRANSFORMER ASSEMBLY

DRAWING NUMBER 800-0130

<u>ITEM NO.</u>	<u>PART NO.</u>	<u>QTY REQD.</u>	<u>DESCRIPTION</u>
1	211-0022	6	Crimp Connector 3/16"
2	211-0042	11	Connector Socket Amp
3	211-0043	1	2-Pin Connector Plug Amp
4	211-0045	1	6-Pin Connector Plug Amp
5	211-0059	1	3-Pin Connector Plug Amp
6	280-0005	9	Cable Tie
7	280-0323	2	Electro Tap Splice Amp
8	560-0054	1	Isolation Transformer
9	600-0079	1ft.	2 Conductor Zip Cord
10	250-0439	1	Transformer Mounting Plate
11	280-0327	2	Base Tie Wrap
12	280-0117	1	Rivet Tab
13	514-0054	1	4 Amp Fast Blow Fuse
14	514-0053	1	5 Amp Slow Blow Fuse
15	514-0001	1	2 Amp Slow Blow Fuse
16	514-0052	1	Quick 3 Position Fuse Block
17		4	Washer #8
18		4	Pop Rivet 3/16 x 1/2
19		2	Pop Rivet 1/8 x 1/2

# Power Transformer Assembly 800-0130

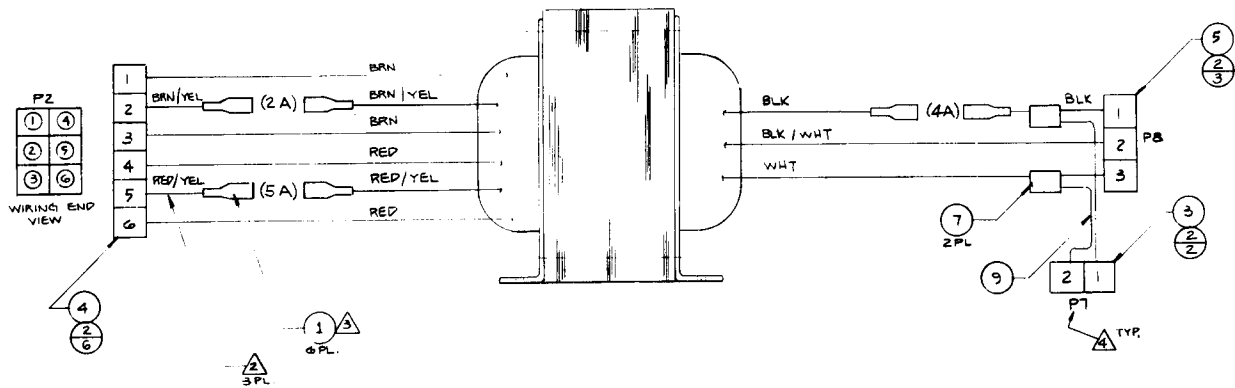
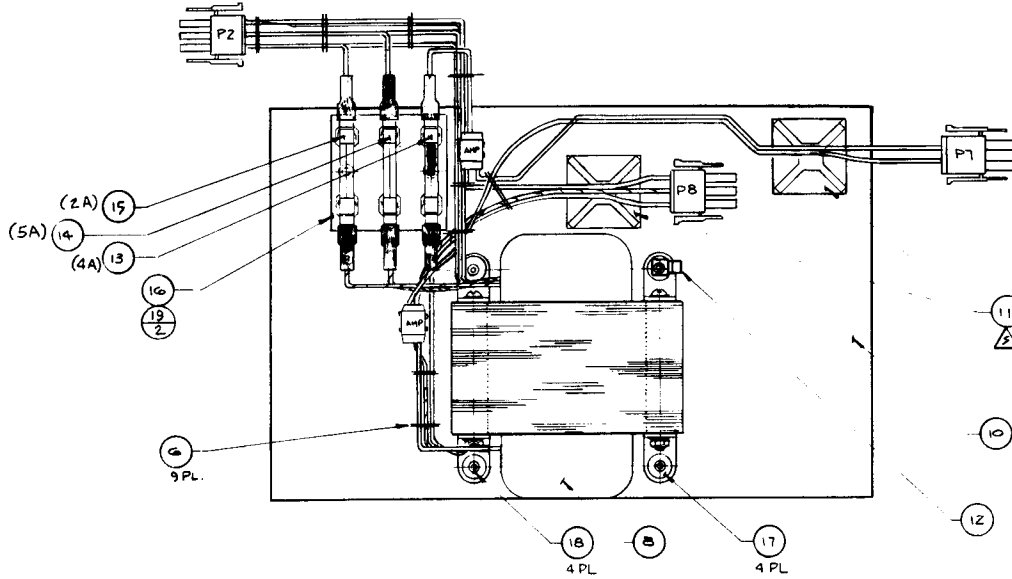

## 19" VERTICAL COLOR MONITOR ASSEMBLY

DRAWING NUMBER 800-0140

<u>ITEM NO.</u>	<u>PART NO.</u>	<u>QTY REQD.</u>	<u>DESCRIPTION</u>
1	200-0019	1	19" Vertical Color Monitor
2			
3			
4	280-0004	1	Hold Down Wire Clip
5			
6	252-0089	1	Vertical Monitor Mounting Board
7		6	Hex Head Machine Bolt $\frac{1}{4}$ -20 x 1 $\frac{1}{4}$
8		12	Flat Washer $\frac{1}{4}$
9		6	Split Lock Washer $\frac{1}{4}$
10		6	Hex Nut $\frac{1}{4}$ -20
11	280-0323	2	Electro Tap Splice Amp
12	800-0159	1	Monitor Power Harness Assembly

# 19" Vertical Color Monitor Assembly 800-0140

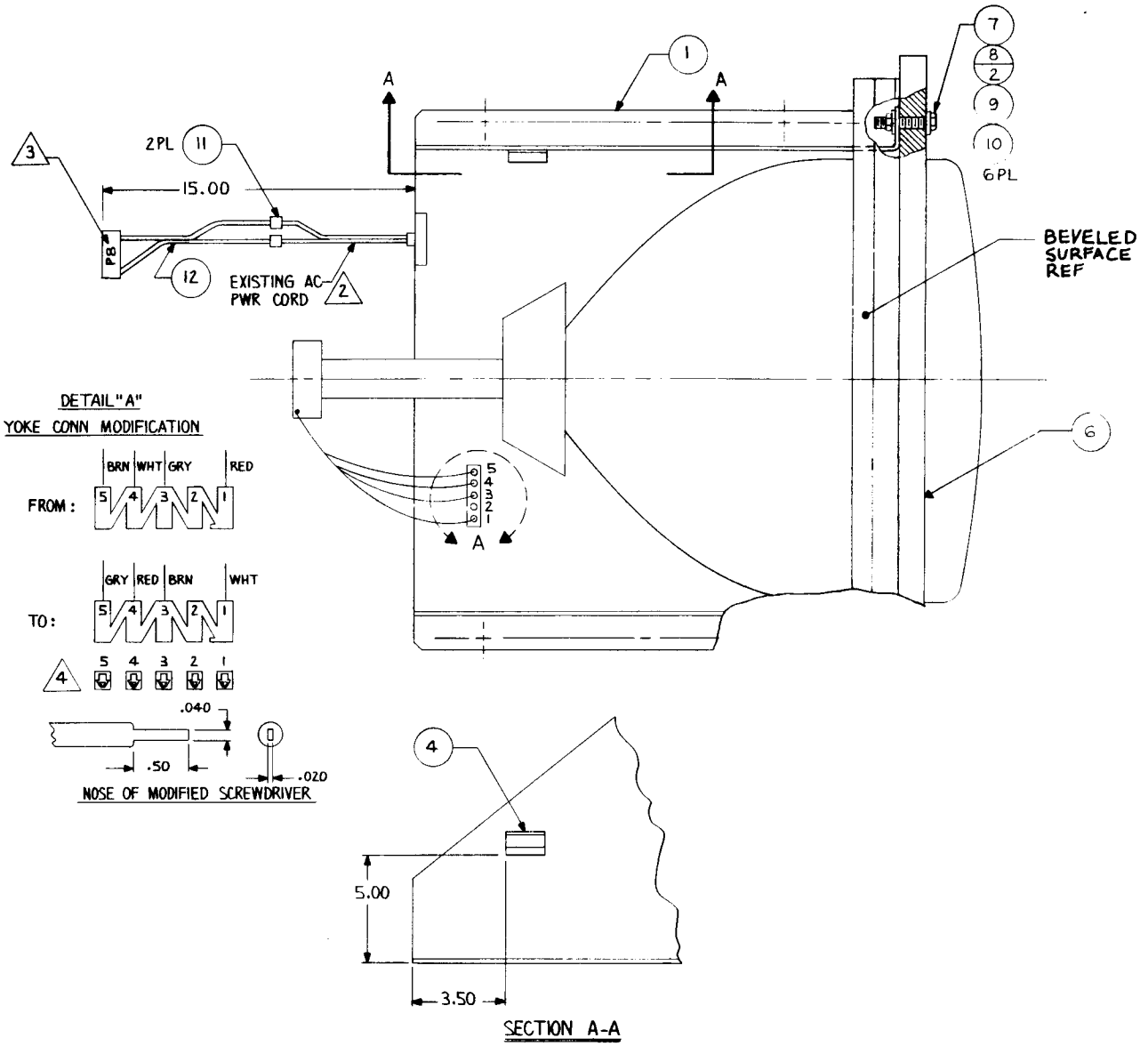

## AC JUNCTION BOX ASSEMBLY

DRAWING NUMBER 800-0145

<u>ITEM NO.</u>	<u>PART NO.</u>	<u>QTY REQD.</u>	<u>DESCRIPTION</u>
1	140-0020	1	Metal Junction Box
2			
3			
4	211-0038	5	Female Quick Connector 3/16
5	280-0361	1	S/REL AC Cord Bushing
6	270-0001	1	EMI Filter
7	280-0007	1	S/REL $\frac{1}{2}$ Bushing
8	280-0362	4	Electric Crimp Sleeve 24-18 AWG
9			
10	510-0013	1	Cherry Switch SPDT
11	514-0001	1	250V Slowblow 2 amp Fuse
12	514-0005	1	Fuse Holder
13	600-0001	1	3 Condition Line Cord
14			
15	600-0079	2ft.	Zip Cord Line
16	280-0005	2	Cable Tie
17		2	Screw, #6-32 x 5/8
18		2	Hex Head Nut #6-32
19		2	Interior Star Lock Washer #6
20		1	Stud #8-32 x 1
21		3	Hex Head Nut #8-32
22		2	Interior Star Lock Washer #8
23		.5ft.	Shrink Tubing - $\frac{1}{4}$ Diameter
24		1	Flat Washer $\frac{1}{4}$ "

<u>ITEM NO.</u>	<u>PART NO.</u>	<u>QTY REQD.</u>	<u>DESCRIPTION</u>
25		1	Hex Head Nut #10-24
26		1	Carriage Bolt #10-24 x 1 3/4"
27	310-0016-16	1	Insulated Tubing .187 ID

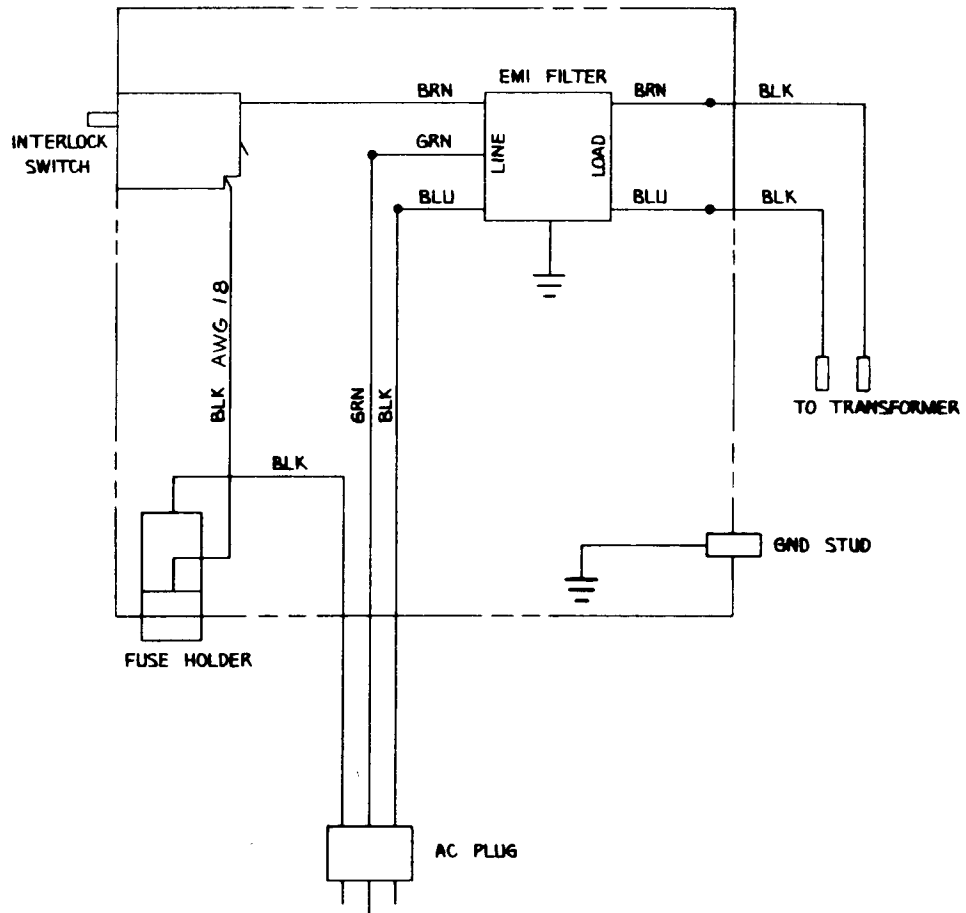

JUNCTION BOX  
SCHEMATIC



# AC Junction Box Assembly 800-0145

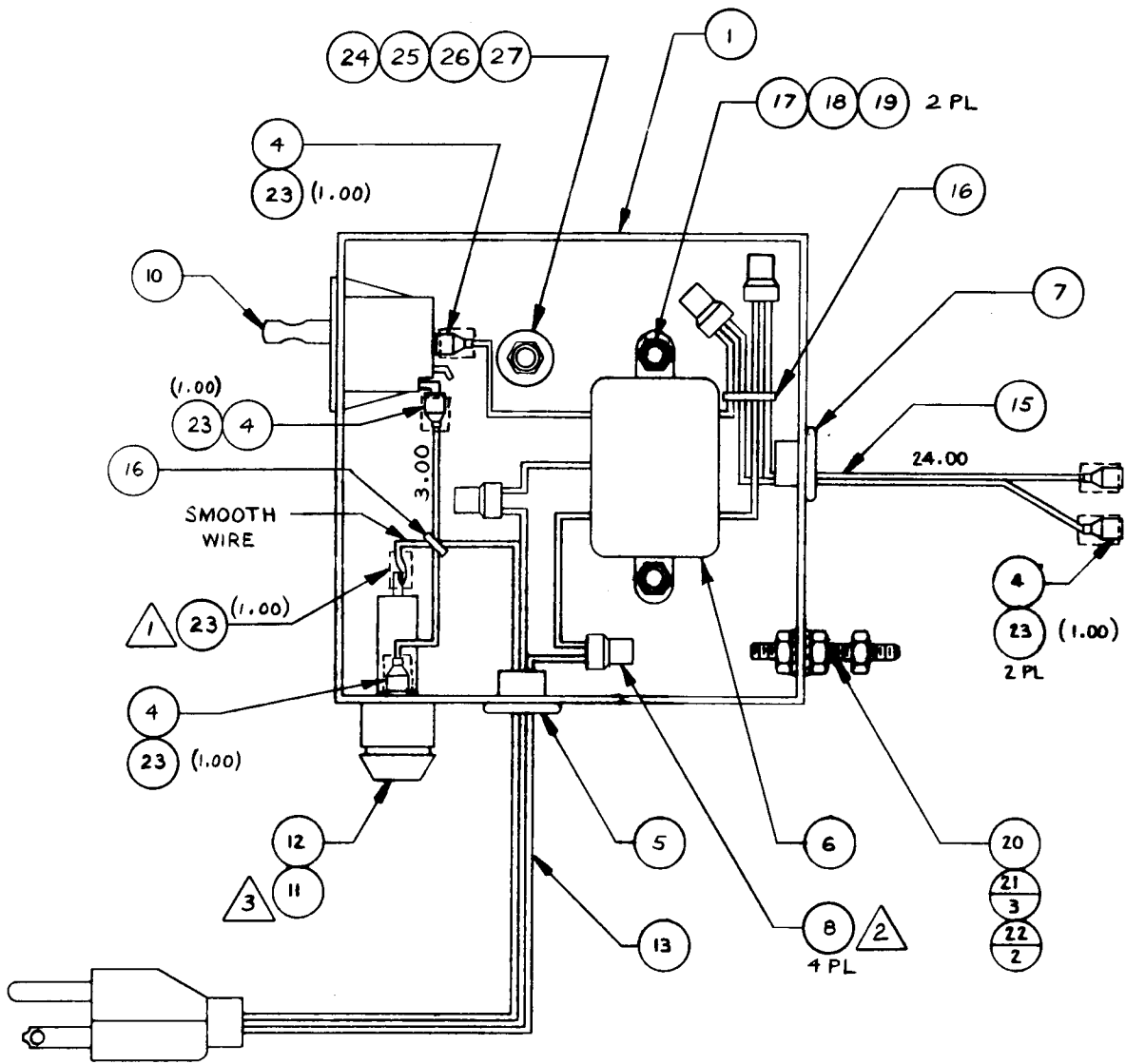

FROGGER GAME ELECTRONICS ASSEMBLY

DRAWING NUMBER 834-0084

<u>ITEM NO.</u>	<u>PART NO.</u>	<u>QTY REQD.</u>	<u>DESCRIPTION</u>
1	834-0085	1	Main IC Board Assembly
2	834-0074	1	Sound Board Assembly

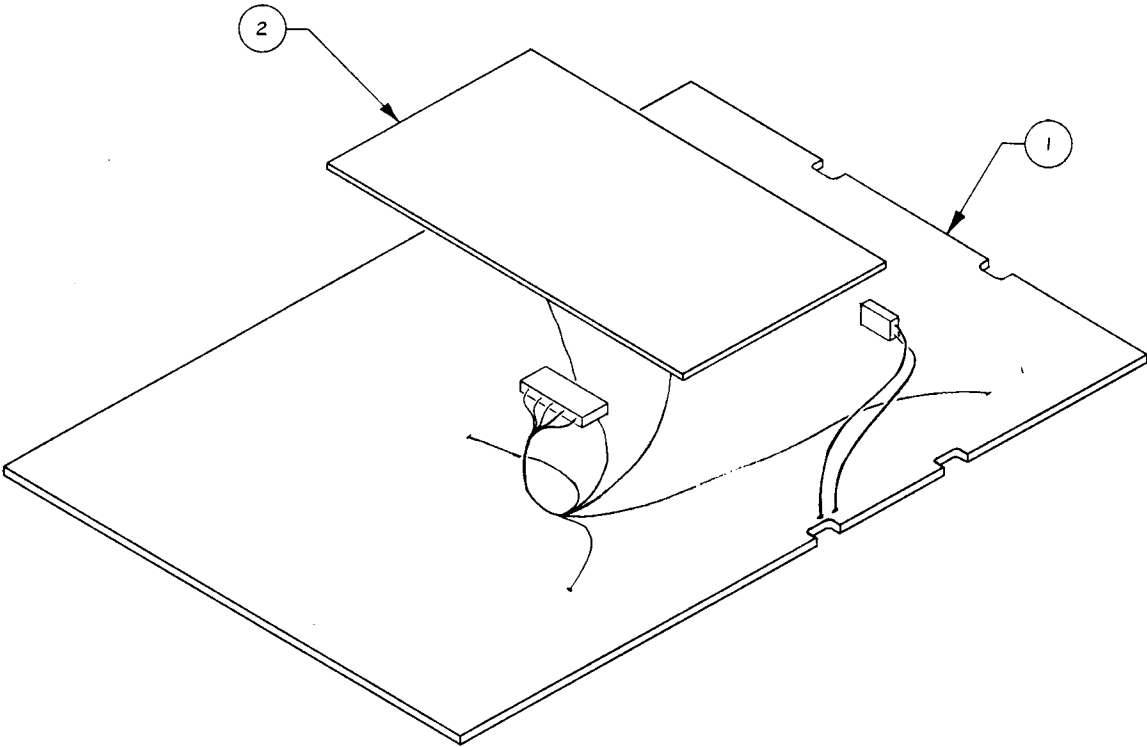

SERVICE SWITCH ASSEMBLY

DRAWING NUMBER 800-3197

<u>ITEM NO.</u>	<u>PART NO.</u>	<u>QTY REQD.</u>	<u>DESCRIPTION</u>
1	250-0068	1	Switch Bracket
2	420-0535	1	Service Switch Decal
3	510-0051	1	Push Button Slide Switch
4	285-0001-04	2	Aluminum Rivet 1/8"

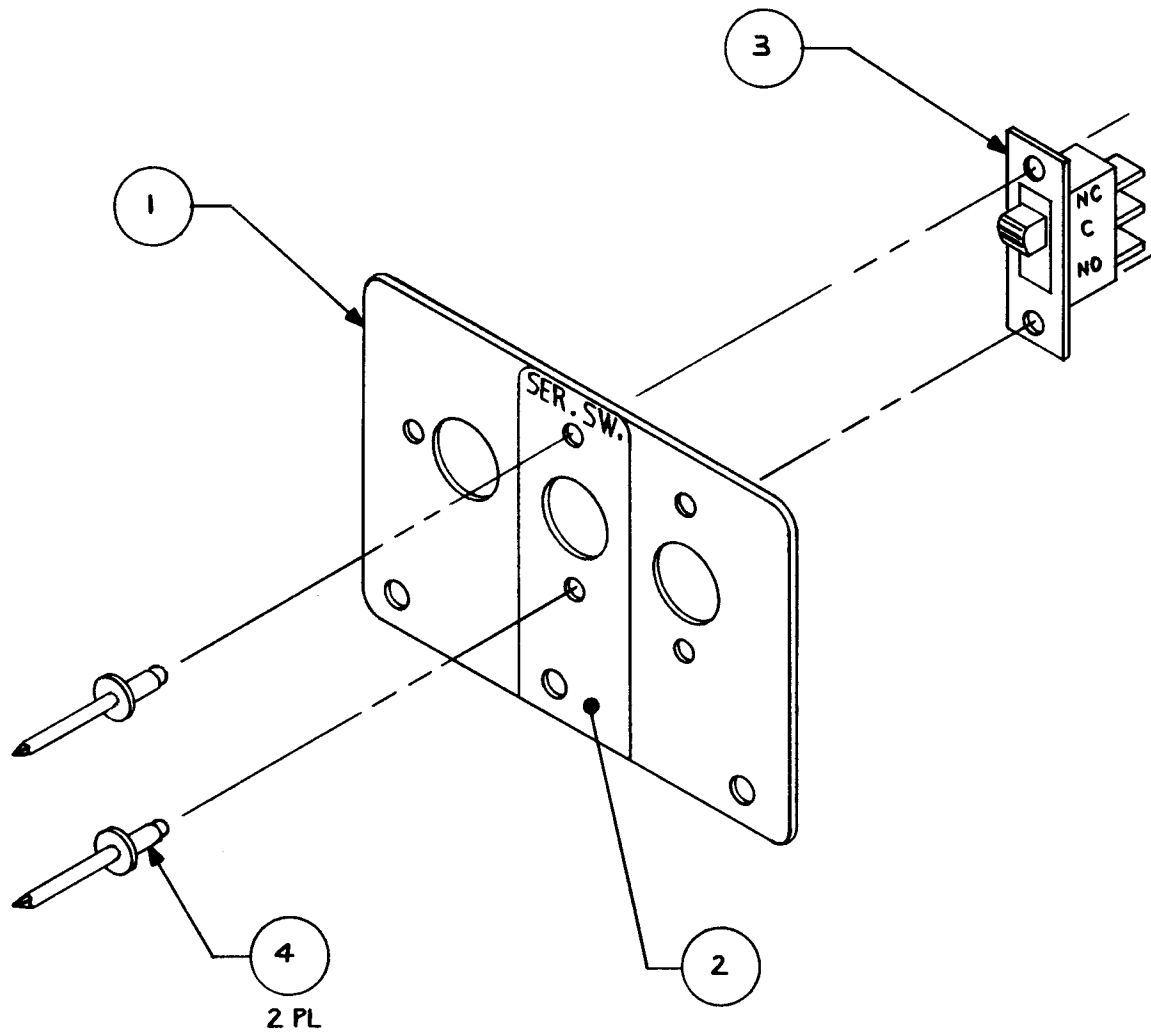

FLUORESCENT LAMP ASSEMBLY

DRAWING NUMBER 800-0147

<u>ITEM NO.</u>	<u>PART NO.</u>	<u>QTY REQD.</u>	<u>DESCRIPTION</u>
1	390-0083	1	18" Fluorescent Lamp Fixture
2	211-0027	1	Ring Lug Connector #10
3		1	Round or Pan Head Machine Screw, #6-32 x 1/2"
4			
5	211-0044	1	Cap Amp Connector, 2-Pin
6	211-0041	2	Pin Amp Connector

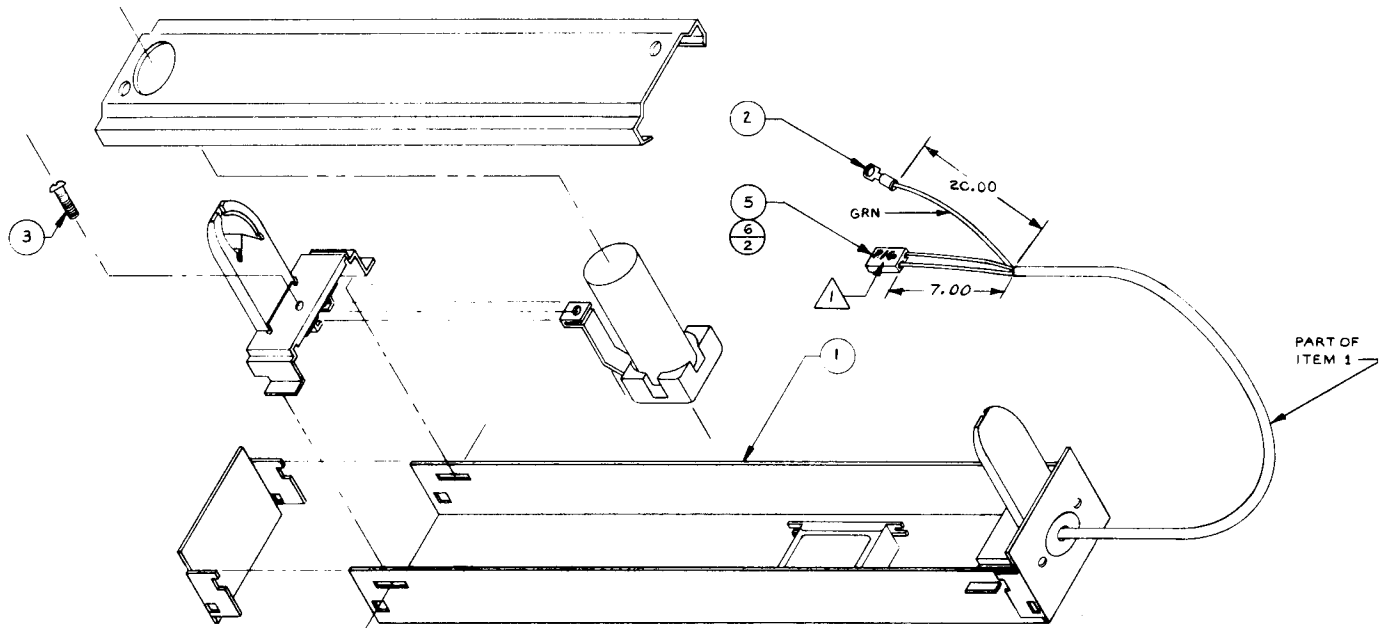

## POWER SUPPLY ASSEMBLY

DRAWING NUMBER 800-0312

<u>ITEM NO.</u>	<u>PART NO.</u>	<u>QTY. REQ'D</u>	<u>DESCRIPTION</u>
1	834-0070	1	Power Supply Assy. (Sega FR-4100)
2	211-0060	1	Conn CAP AMP 3 Pin
3	211-0043	1	Conn Plug AMP 2 Pin
4	280-0117	1	Tab Rivet 1/4"
5	211-0059	1	Conn Plug AMP 3 Pin
6	211-0042	4	Conn Socket
7	212-0006	1	Conn Fem 10 Pin
8	211-0005	8	Conn Crimp
9	280-0359	2	Electric Crimp Sleeve
10	280-0005	3	Cable Tie

# Power Supply Assembly 800-0312

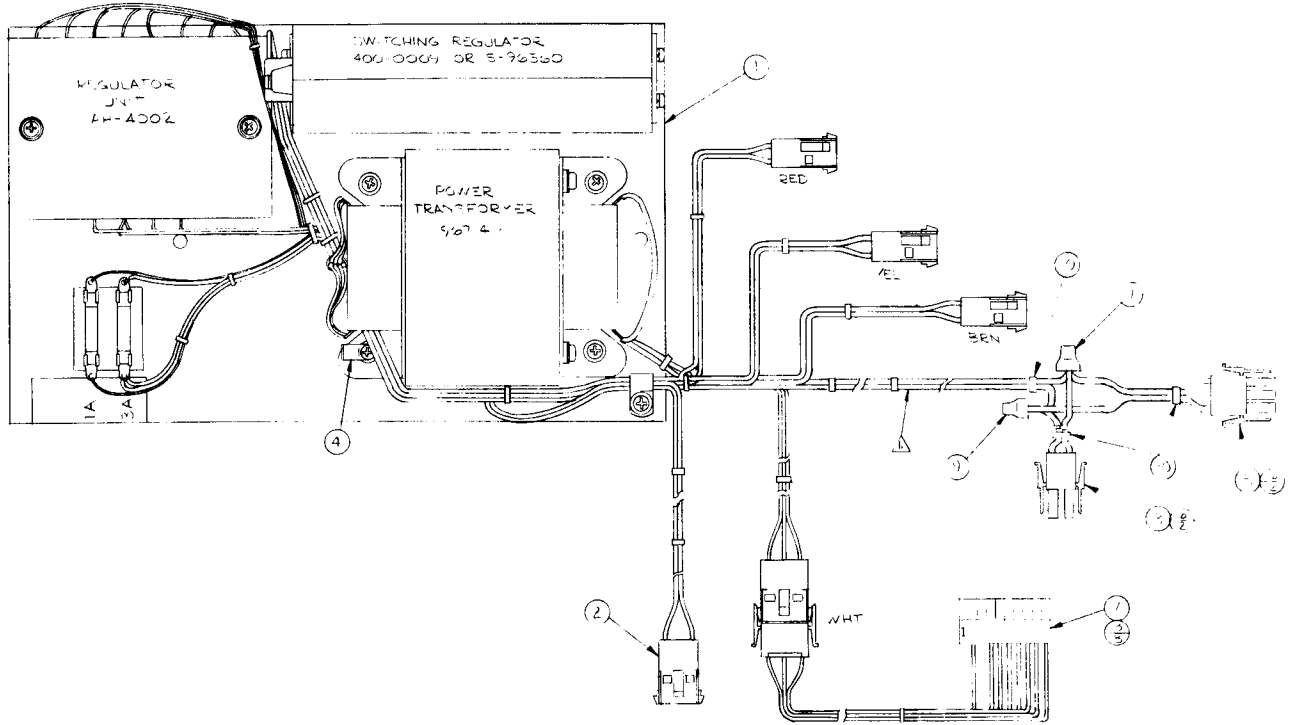

REVISIONS				
ZONE	LTR	DESCRIPTION	DATE	APPROVED
	SEE SH #1		SD 9-1-81	

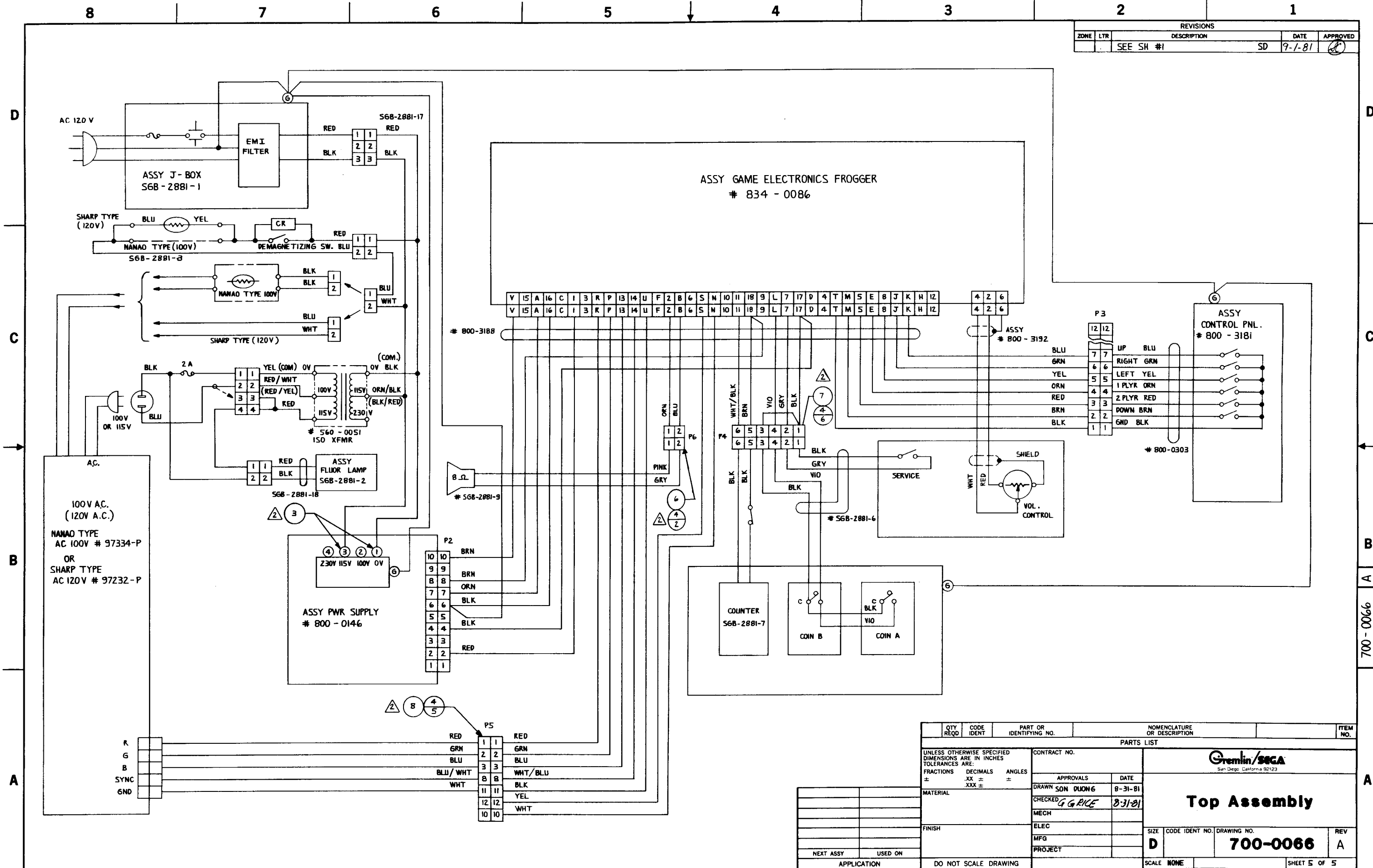

QTY REQD	CODE IDENT	PART OR IDENTIFYING NO.	NOMENCLATURE OR DESCRIPTION	ITEM NO.
PARTS LIST				
UNLESS OTHERWISE SPECIFIED DIMENSIONS ARE IN INCHES TOLERANCES ARE:		CONTRACT NO.		
FRACTIONS	DECIMALS	ANGLES	APPROVALS	
±	.XX ±	±	DATE	
	.XXX ±		DRAWN SON DUONG 8-31-81	
MATERIAL		CHECKED G. RICE 8-31-81		
FINISH		MECH		
NEXT ASSY		ELEC		
USED ON		MFG		
APPLICATION		PROJECT		
DO NOT SCALE DRAWING		SIZE CODE IDENT NO. DRAWING NO. REV		
SCALE NONE		D 700-0066 A		
		SHEET 5 OF 5		

700-0066

REVISIONS				
ZONE	LTR	DESCRIPTION	DATE	APPROVED
		SEE SHT. 1	SD 8-31-81	<i>[Signature]</i>

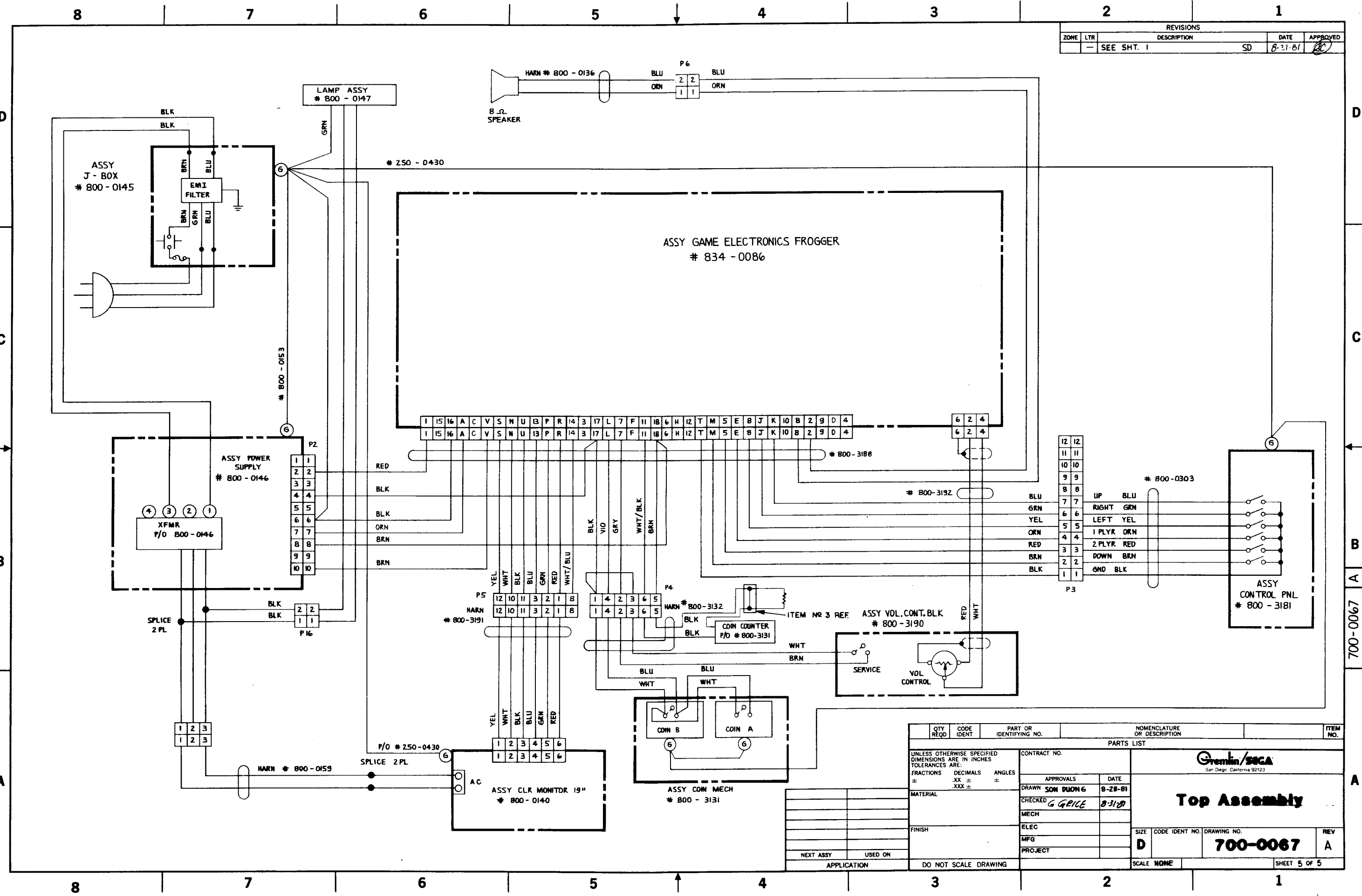

QTY REQD	CODE IDENT	PART OR IDENTIFYING NO.	NOMENCLATURE OR DESCRIPTION	ITEM NO.
PARTS LIST				
UNLESS OTHERWISE SPECIFIED DIMENSIONS ARE IN INCHES TOLERANCES ARE:				
FRACTIONS	DECIMALS	ANGLES		
±	.XX ±	±		
MATERIAL				
FINISH				
APPLICATION				
DO NOT SCALE DRAWING		SCALE NONE		

CONTRACT NO.	
APPROVALS	DATE
DRAWN <b>SON DUONG</b>	8-28-81
CHECKED <b>G GPICE</b>	8-31-81
MECH	
ELEC	
MFG	
PROJECT	

**Gremlin/SEGA**  
San Diego, California 92123

## Top Assembly

SIZE <b>D</b>	CODE IDENT NO.	DRAWING NO. <b>700-0067</b>	REV <b>A</b>
SHEET 5 OF 5			



REVISIONS				
ZONE	LTR	DESCRIPTION	DATE	APPROVED
		SEE SH #1	SD	9481

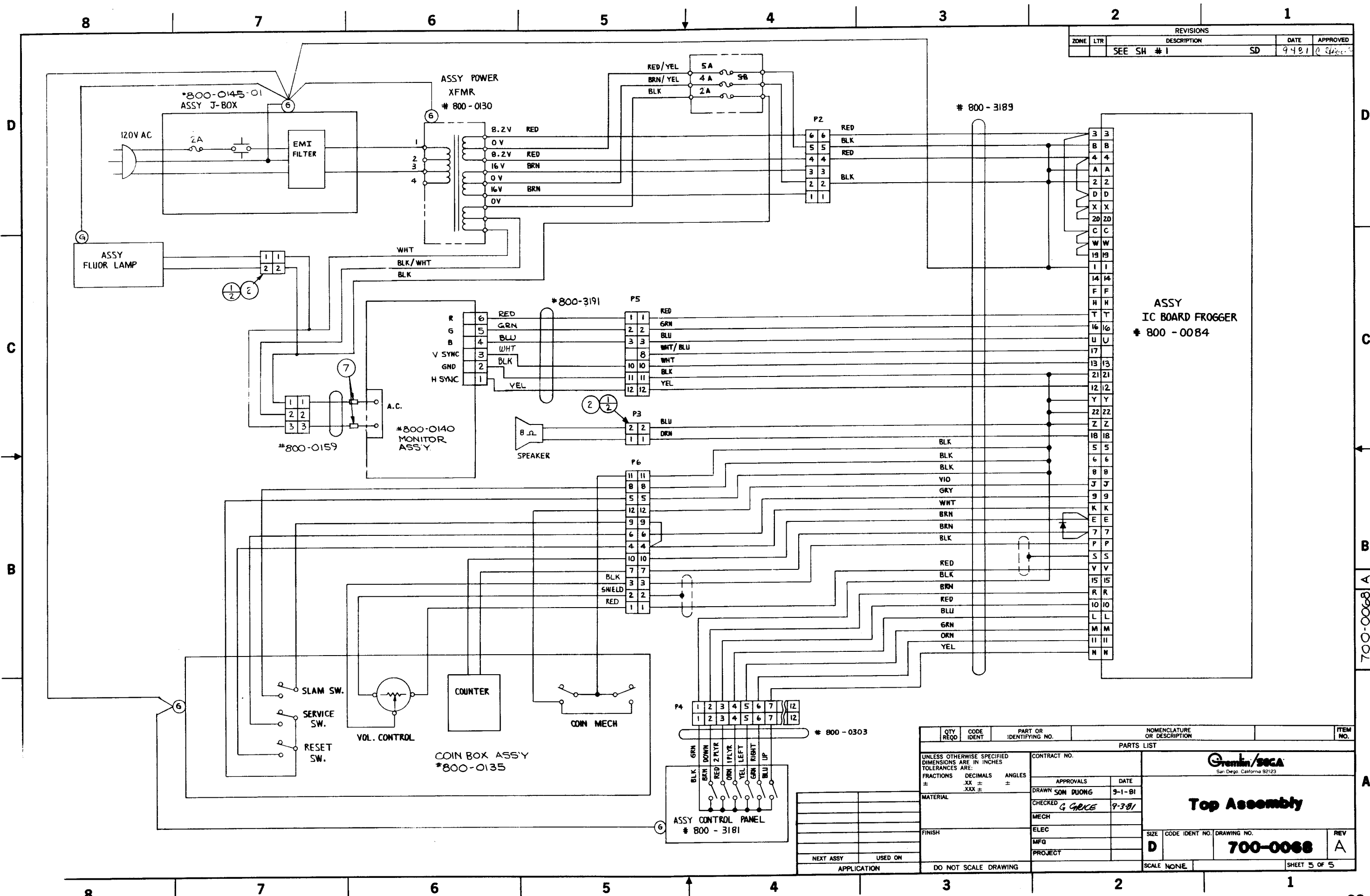

QTY REQD	CODE IDENT	PART OR IDENTIFYING NO.	NOMENCLATURE OR DESCRIPTION	ITEM NO.
PARTS LIST				
UNLESS OTHERWISE SPECIFIED DIMENSIONS ARE IN INCHES TOLERANCES ARE:		CONTRACT NO.		
FRACTIONS	DECIMALS	ANGLES	APPROVALS	
±	.XX ±	±	DRAWN SOM DUONG 9-1-81	
	.XXX ±		CHECKED G. GRICE 9-3-81	
MATERIAL		ELEC		SIZE
FINISH		MFG		CODE IDENT NO. DRAWING NO.
NEXT ASSY		PROJECT		<b>D</b> <b>700-0068</b>
APPLICATION		DO NOT SCALE DRAWING		REV <b>A</b>
SCALE NONE				SHEET 5 OF 5

700-0068

REVISIONS				
ZONE	LYR	DESCRIPTION	DATE	APPROVED
		SEE SH #1	SD	9-4-81 C. Hester

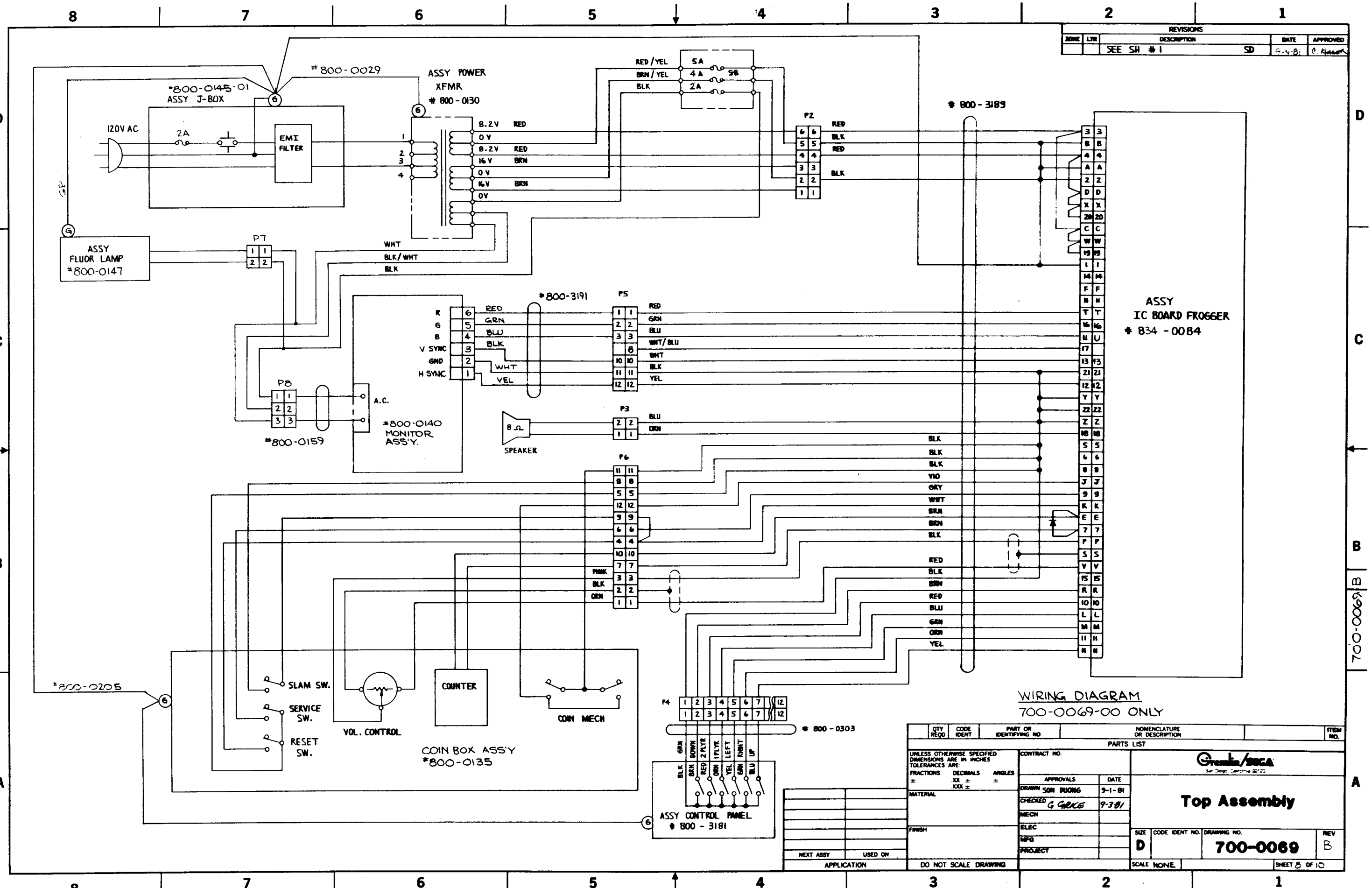

REVISIONS				
ZONE	LTR	DESCRIPTION	DATE	APPROVED
		SEE SH # 1	SD	9-2-81

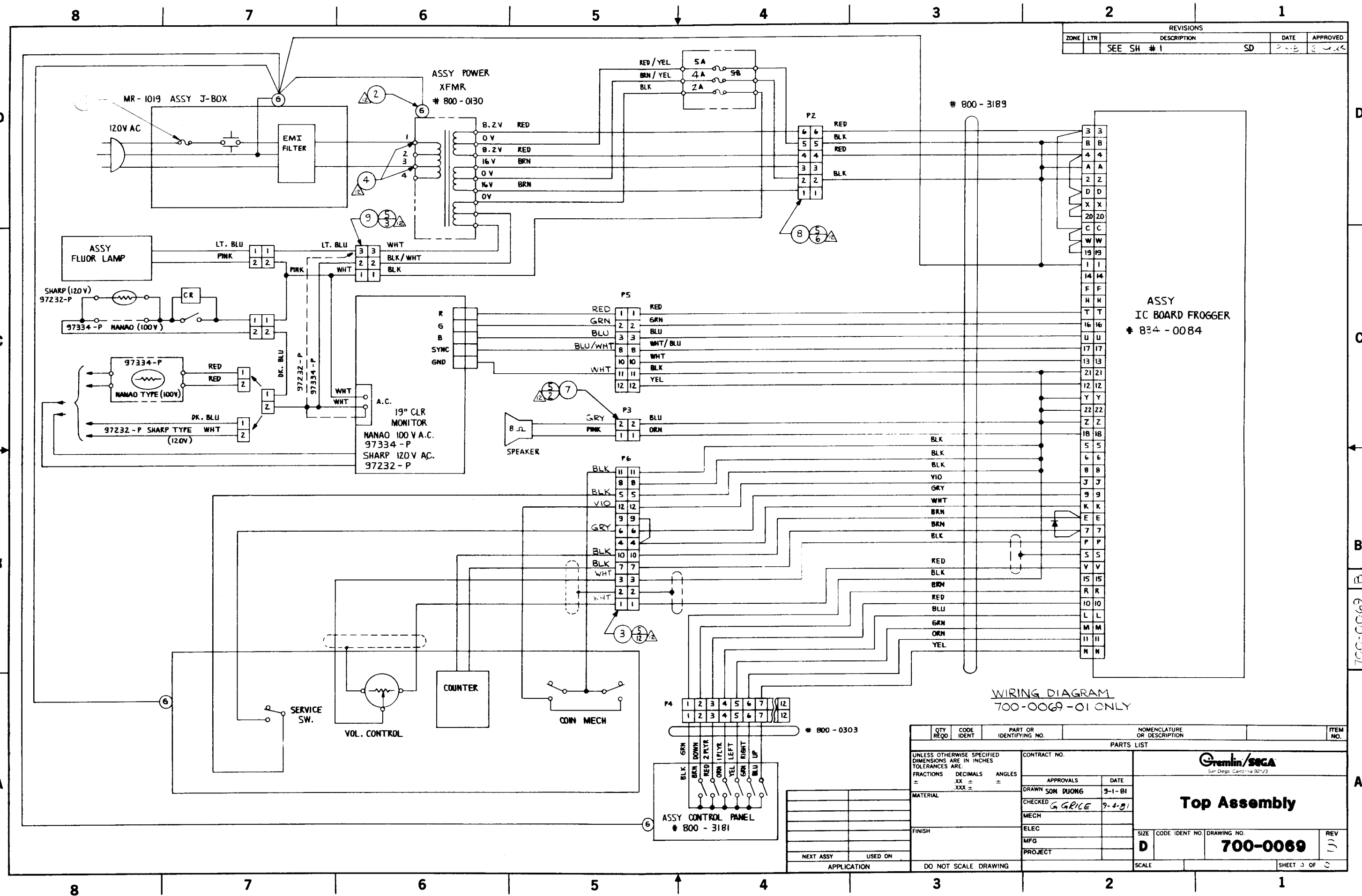

700-0069

REVISIONS				DATE	APPRO.
ZONE	LTR	DESCRIPTION			
		SEE SH # 1	SD	9-4-81	

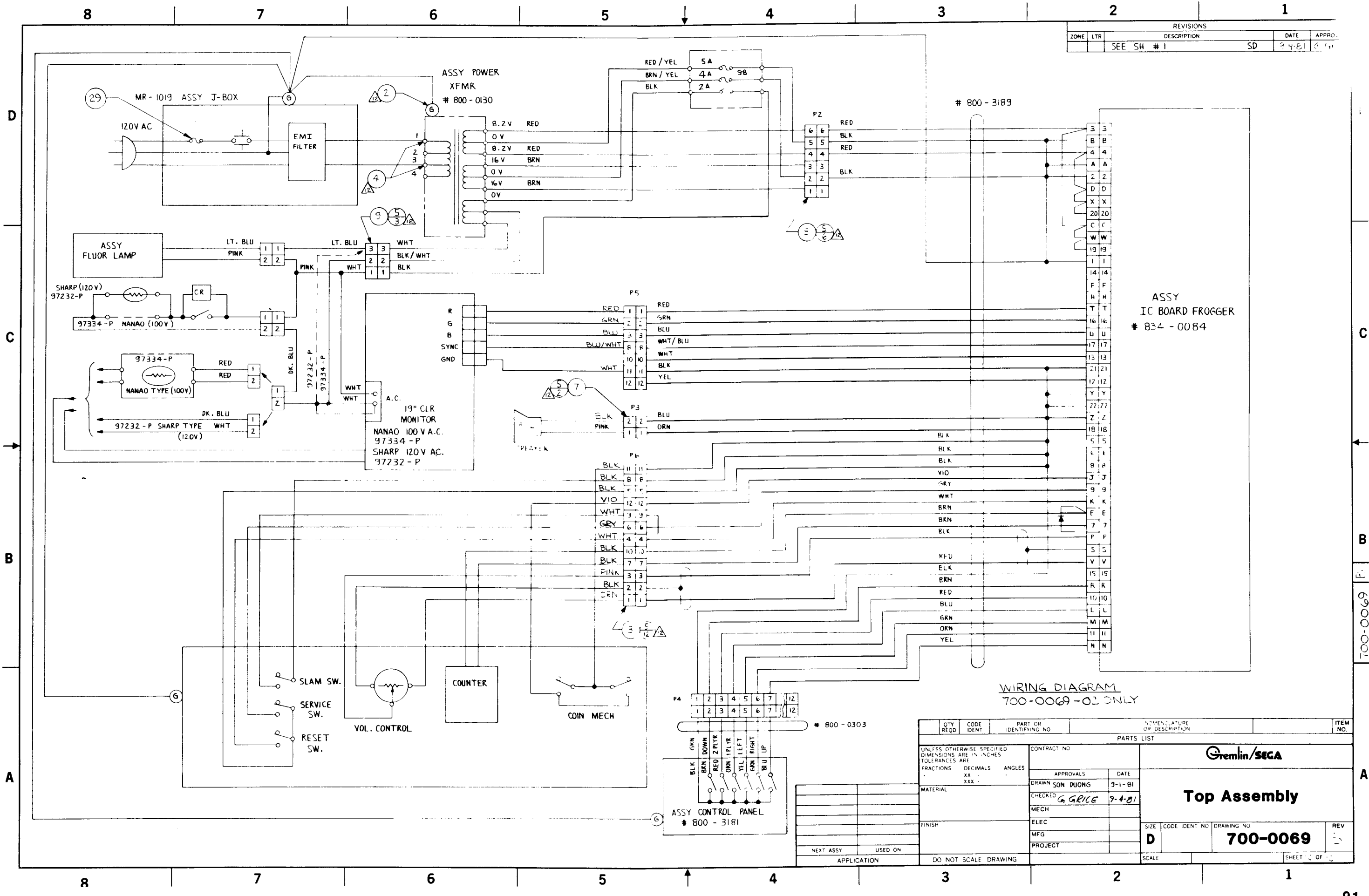

WIRING DIAGRAM  
700-0069-02 ONLY

QTY REQD	CODE IDENT	PART OR IDENTIFYING NO	NOMENCLATURE OR DESCRIPTION	ITEM NO.
PARTS LIST				
UNLESS OTHERWISE SPECIFIED DIMENSIONS ARE IN INCHES TOLERANCES ARE FRACTIONS DECIMALS ANGLES		CONTRACT NO		
		APPROVALS DATE		
MATERIAL		DRAWN SON DUONG 9-1-81		
		CHECKED G. GRICE 9-4-81		
FINISH		MECH		
		ELEC		
NEXT ASSY USED ON		MFG		
APPLICATION		PROJECT		
		SIZE CODE IDENT NO DRAWING NO		
		D 700-0069		
		REV		
		SCALE SHEET 1 OF 1		

REVISIONS				
ZONE	LTR	DESCRIPTION	DATE	APPROVED
		SEE SH # 1	SD 7-10-81	(Signature)

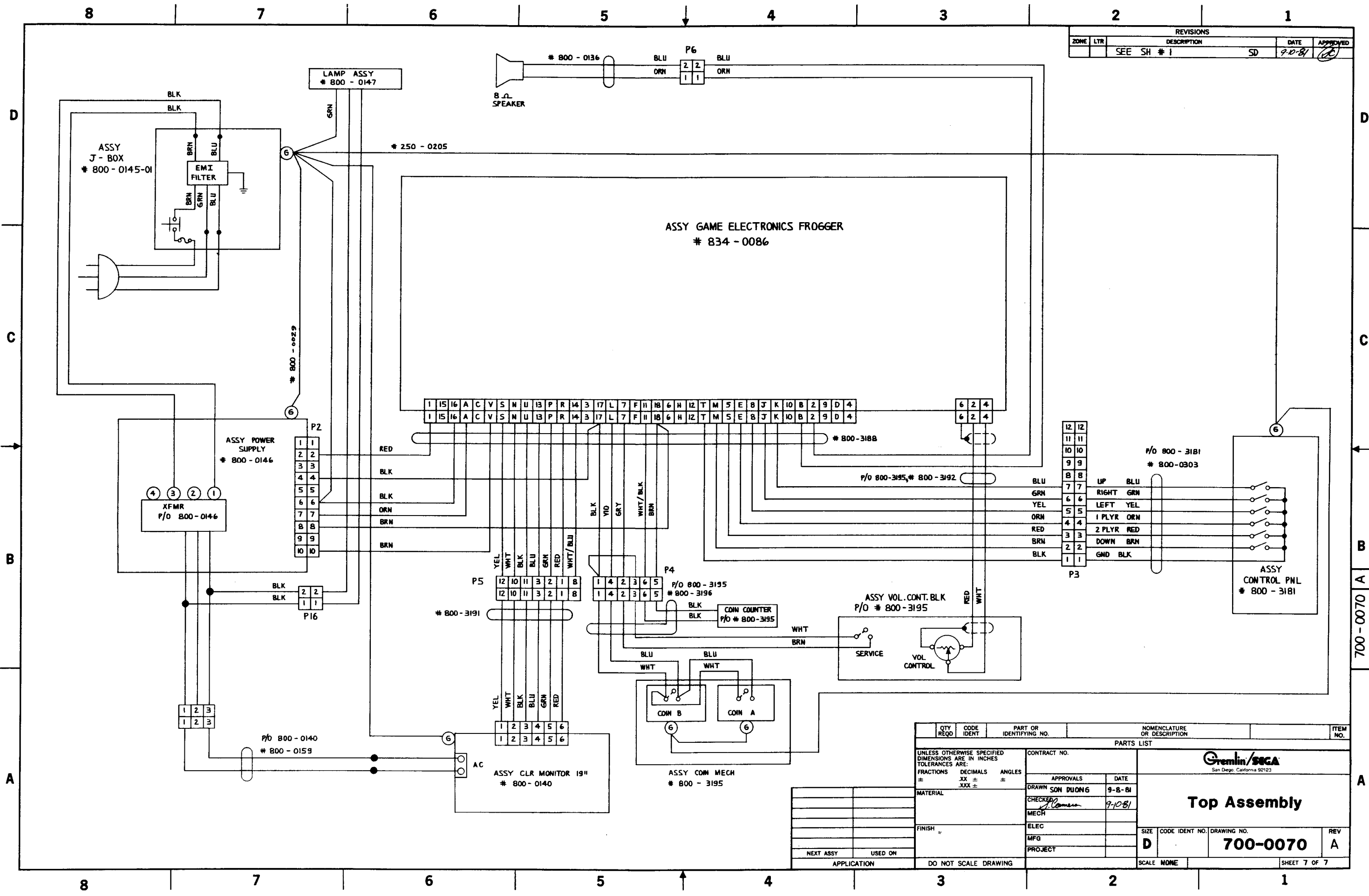

QTY REQD	CODE IDENT	PART OR IDENTIFYING NO.	NOMENCLATURE OR DESCRIPTION	ITEM NO.
PARTS LIST				
UNLESS OTHERWISE SPECIFIED DIMENSIONS ARE IN INCHES TOLERANCES ARE:		CONTRACT NO.		
FRACTIONS	DECIMALS	ANGLES	APPROVALS	DATE
±	.XX ±	±	DRAWN SON DUONG	9-8-81
	.XXX ±		CHECKED (Signature)	7-10-81
MATERIAL		ELEC		
FINISH		MFG		
NEXT ASSY		PROJECT		
USED ON		SCALE NONE		
APPLICATION		DO NOT SCALE DRAWING		

**Gremlin/SECA**  
 San Diego, California 92123  
**Top Assembly**  
 SIZE CODE IDENT NO. DRAWING NO. REV  
**D 700-0070 A**  
 SHEET 7 OF 7

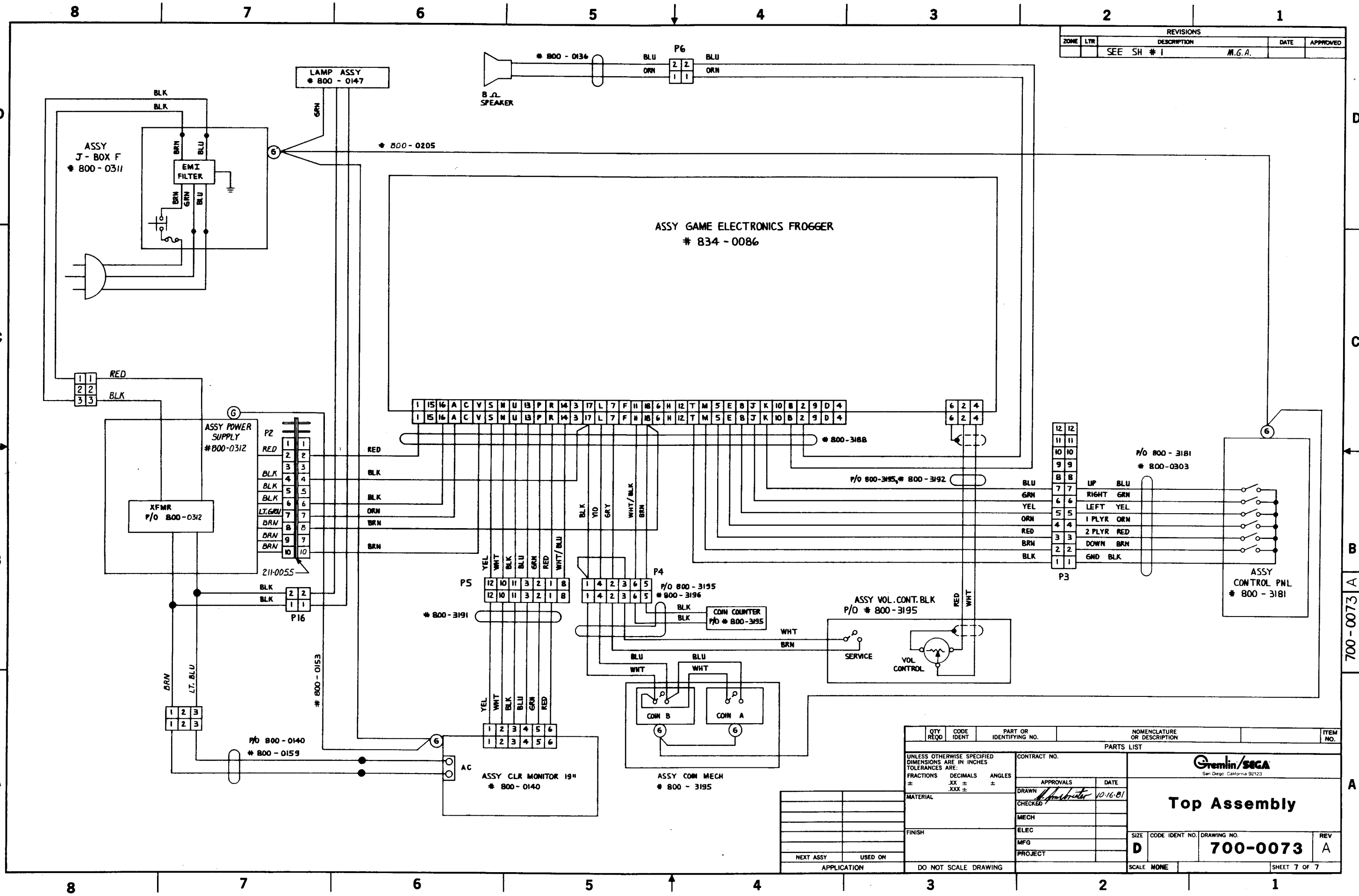

REVISIONS				
ZONE	LTR	DESCRIPTION	DATE	APPROVED
		SEE SH # 1	M.G.A.	

QTY	CODE	PART OR IDENTIFYING NO.	NOMENCLATURE OR DESCRIPTION	ITEM NO.
PARTS LIST				
UNLESS OTHERWISE SPECIFIED DIMENSIONS ARE IN INCHES TOLERANCES ARE:				
FRACTIONS	DECIMALS	ANGLES		
±	.XX ±	±		
±	.XXX ±			
MATERIAL		CONTRACT NO.		
FINISH		APPROVALS DATE		
NEXT ASSY USED ON		DRAWN <i>[Signature]</i> 10-16-81		
APPLICATION		CHECKED		
DO NOT SCALE DRAWING		MECH		
		ELEC		
		MFG		
		PROJECT		
		SIZE CODE IDENT NO. DRAWING NO. REV		
		D 700-0073 A		
		SCALE NONE SHEET 7 OF 7		

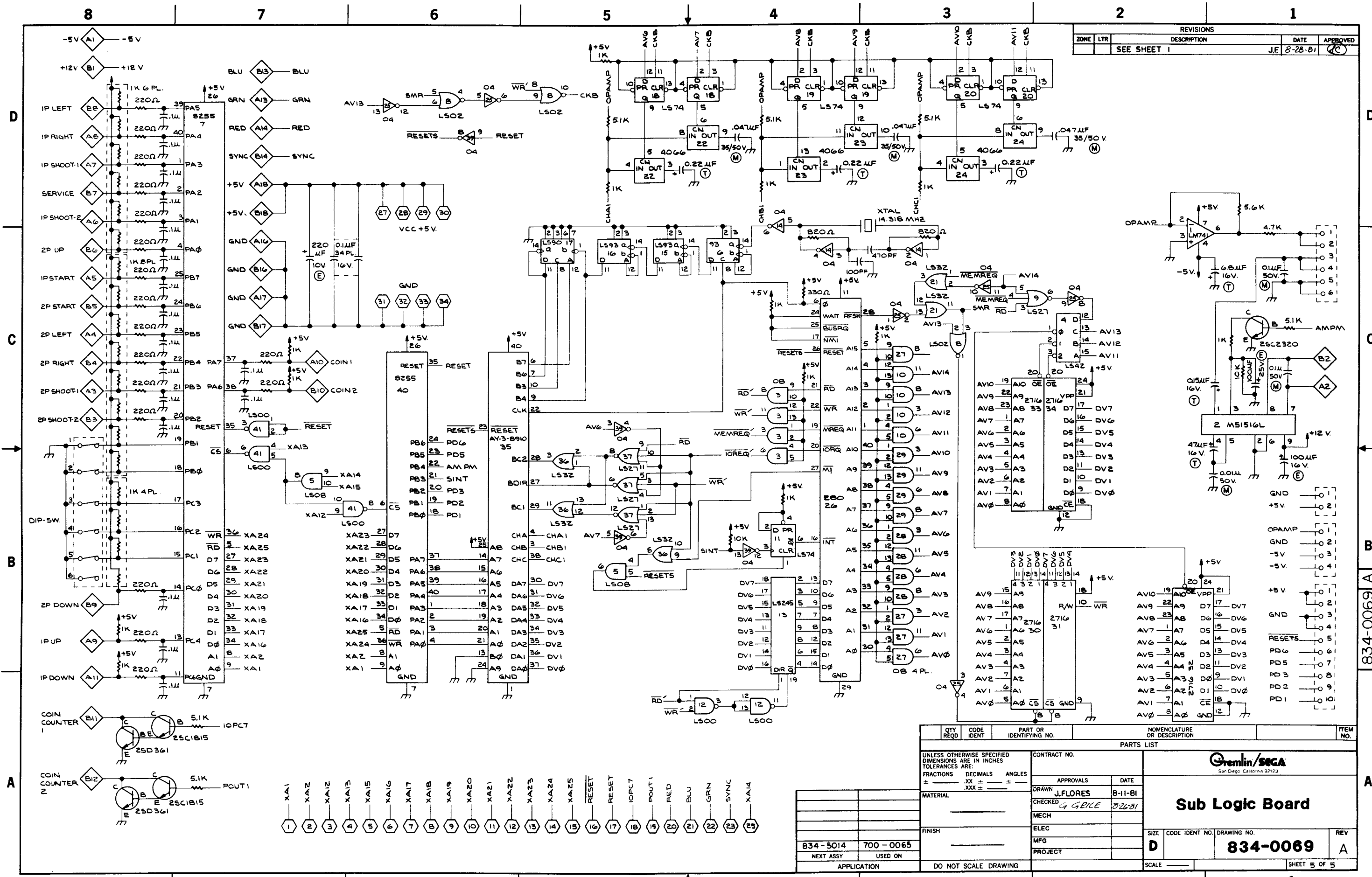

REVISIONS			
ZONE	LTR	DESCRIPTION	DATE
		SEE SHEET 1	J.F. 8-28-81

QTY REQD	CODE IDENT	PART OR IDENTIFYING NO.	NOMENCLATURE OR DESCRIPTION	ITEM NO.
PARTS LIST				
UNLESS OTHERWISE SPECIFIED DIMENSIONS ARE IN INCHES TOLERANCES ARE:				
FRACTIONS    DECIMALS    ANGLES				
±                .XX ±                °				
MATERIAL				
FINISH				
CONTRACT NO.				
DRAWN J.FLORES		DATE 8-11-81		
CHECKED G. GRICE		DATE 8-26-81		
MECH				
ELEC				
MFG				
PROJECT				
834-5014		700-0065		
NEXT ASSY		USED ON		
APPLICATION      DO NOT SCALE DRAWING				
Gremlin/SEGA San Diego, California 92123				
<b>Sub Logic Board</b>				
SIZE	CODE IDENT NO.	DRAWING NO.	REV	
D		834-0069	A	
SCALE				SHEET 5 OF 5

834-0069 A

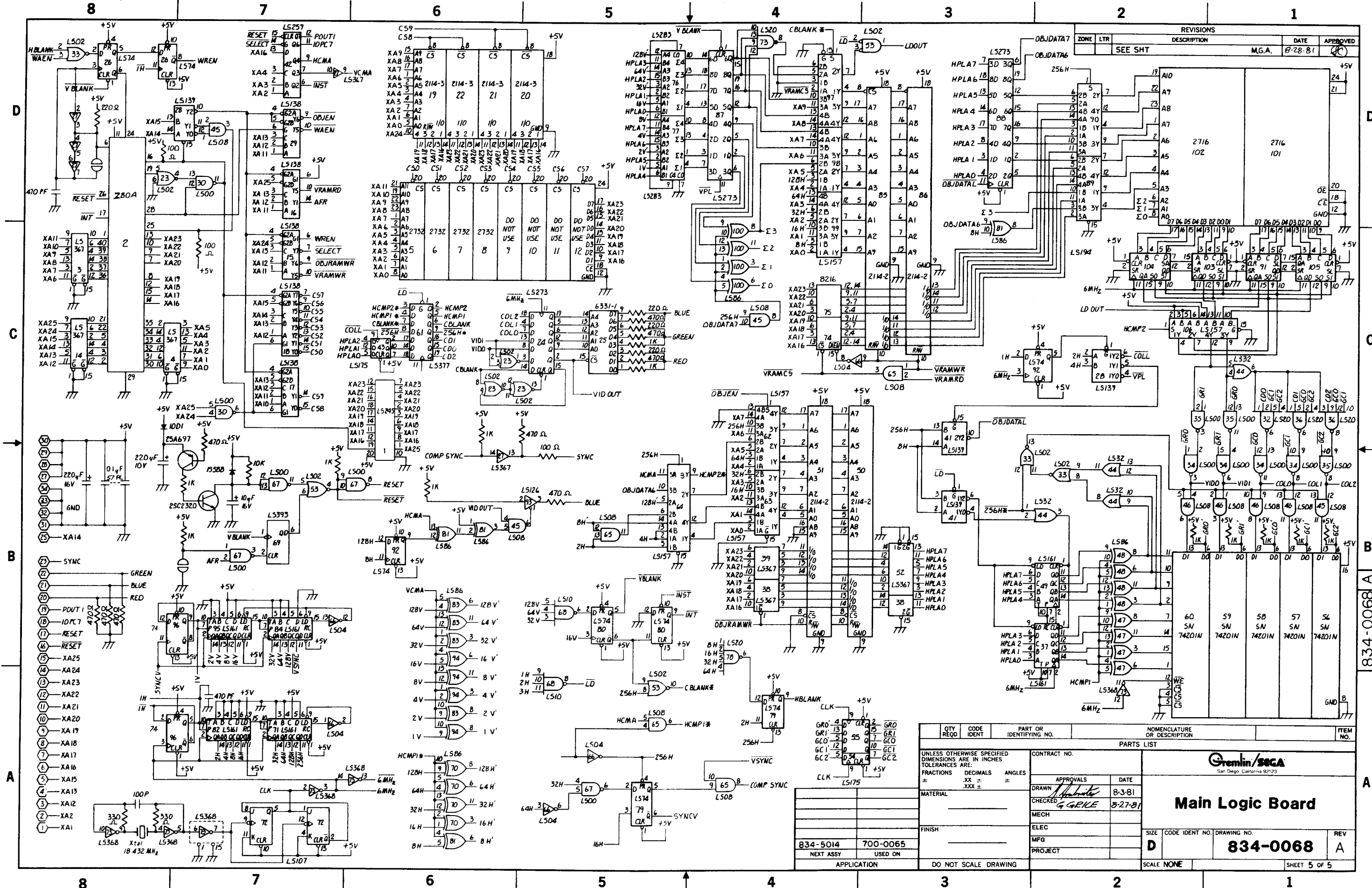

REVISIONS				
ZONE	LTR	DESCRIPTION	DATE	APPROVED
SEE SHT			M.G.A.	8-28-81

QTY REQD	CODE IDENT	PART OR IDENTIFYING NO.	NOMENCLATURE OR DESCRIPTION	ITEM NO.
PARTS LIST				
UNLESS OTHERWISE SPECIFIED DIMENSIONS ARE IN INCHES TOLERANCES ARE:		CONTRACT NO.		
FRACTIONS	DECIMALS	ANGLES	APPROVALS	DATE
±	.XX ±	±	<i>[Signature]</i>	8-3-81
MATERIAL		CHECKED <i>G. GRIFFIN</i> 8-27-81		
FINISH		MECH		
ELEC		MFG		
PROJECT		REV		
834-5014		700-0065		834-0068
NEXT ASSY		USED ON		SCALE NONE
APPLICATION		DO NOT SCALE DRAWING		SHEET 5 OF 5

**Grenin/SGA**  
San Diego, California 92123

**Main Logic Board**

SIZE CODE IDENT NO. DRAWING NO. **834-0068** REV **A**

834-0068 A



REVISIONS				
ZONE	LTR	DESCRIPTION	DATE	APPROVED
A		RELEASED	CTC/LVH 7-23-80	<i>[Signature]</i>
B		PER ECN # 554	12-09-80	<i>[Signature]</i>
C		PER ECN # 546	12-09-80	<i>[Signature]</i>
D		PER ECN # 565	12-10-80	<i>[Signature]</i>
E		PER ECN # 631	UJB 1-26-81	<i>[Signature]</i>
F		PER ECN # 800	CTC 4-20-81	<i>[Signature]</i>

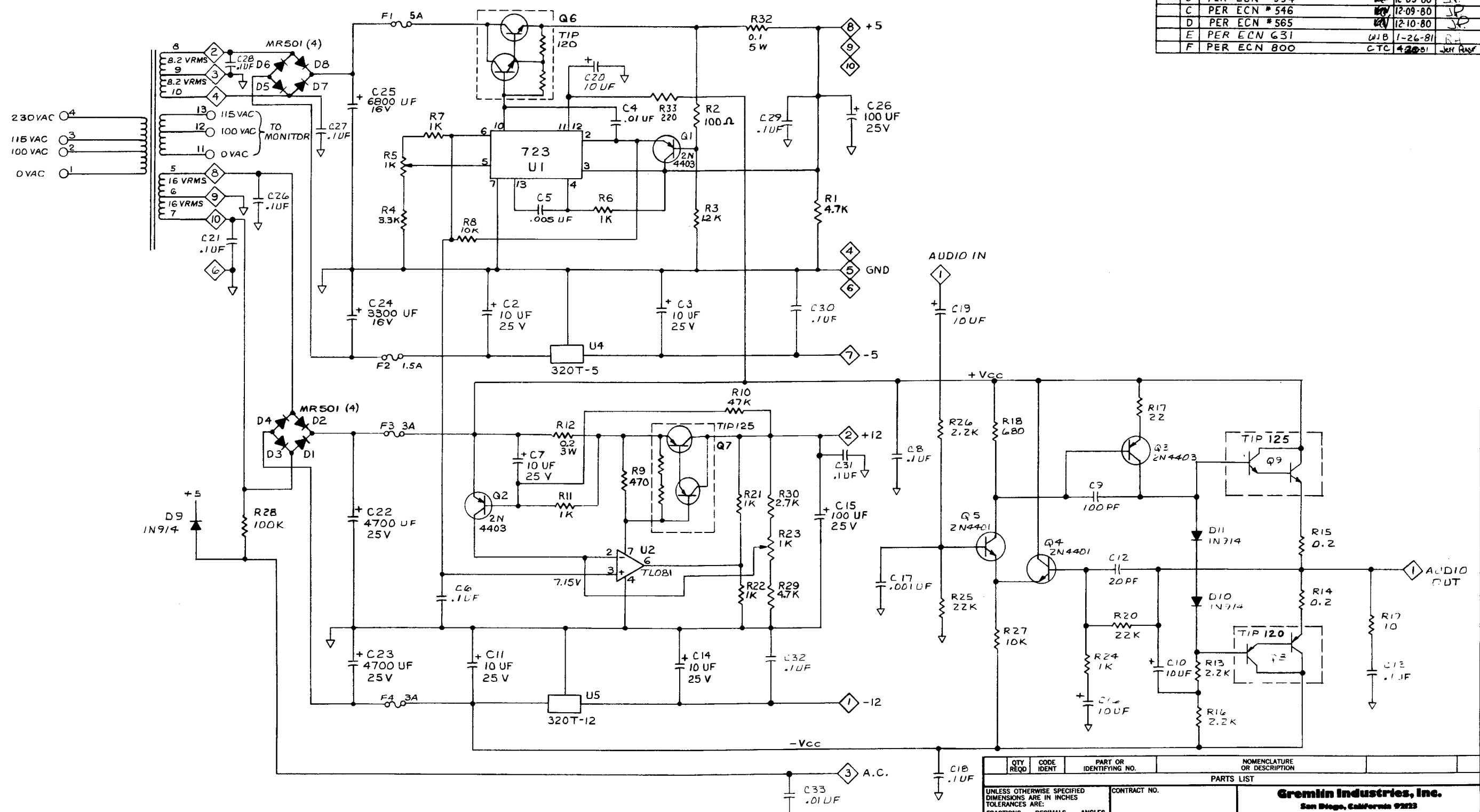

1. ALL RESISTANCE VALUES ARE IN OHMS, 1/2W, ±5%.  
 NOTES: UNLESS OTHERWISE INDICATED

QTY REQD	CODE IDENT	PART OR IDENTIFYING NO.	NOMENCLATURE OR DESCRIPTION
PARTS LIST			
UNLESS OTHERWISE SPECIFIED DIMENSIONS ARE IN INCHES TOLERANCES ARE:			
FRACTIONS	DECIMALS	ANGLES	
±	.XX ±	±	
	.XXX ±		
MATERIAL		CONTRACT NO.	
FINISH		APPROVALS	
NEXT ASSY		DATE	
USED ON		DRAWN <i>[Signature]</i> 7-2-80	
APPLICATION		CHECKED <i>[Signature]</i> 9-23-80	
DO NOT SCALE DRAWING		DRAWN <i>[Signature]</i> 7-2-80	
		CHECKED <i>[Signature]</i> 9-23-80	

**Gremlin Industries, Inc.**  
 San Diego, California 92123

**Game Power Supply**

SIZE: D CODE IDENT NO.: 800-0128 DRAWING NO.: 800-0128 REV. F

SCALE: NONE SHEET 6 OF 6

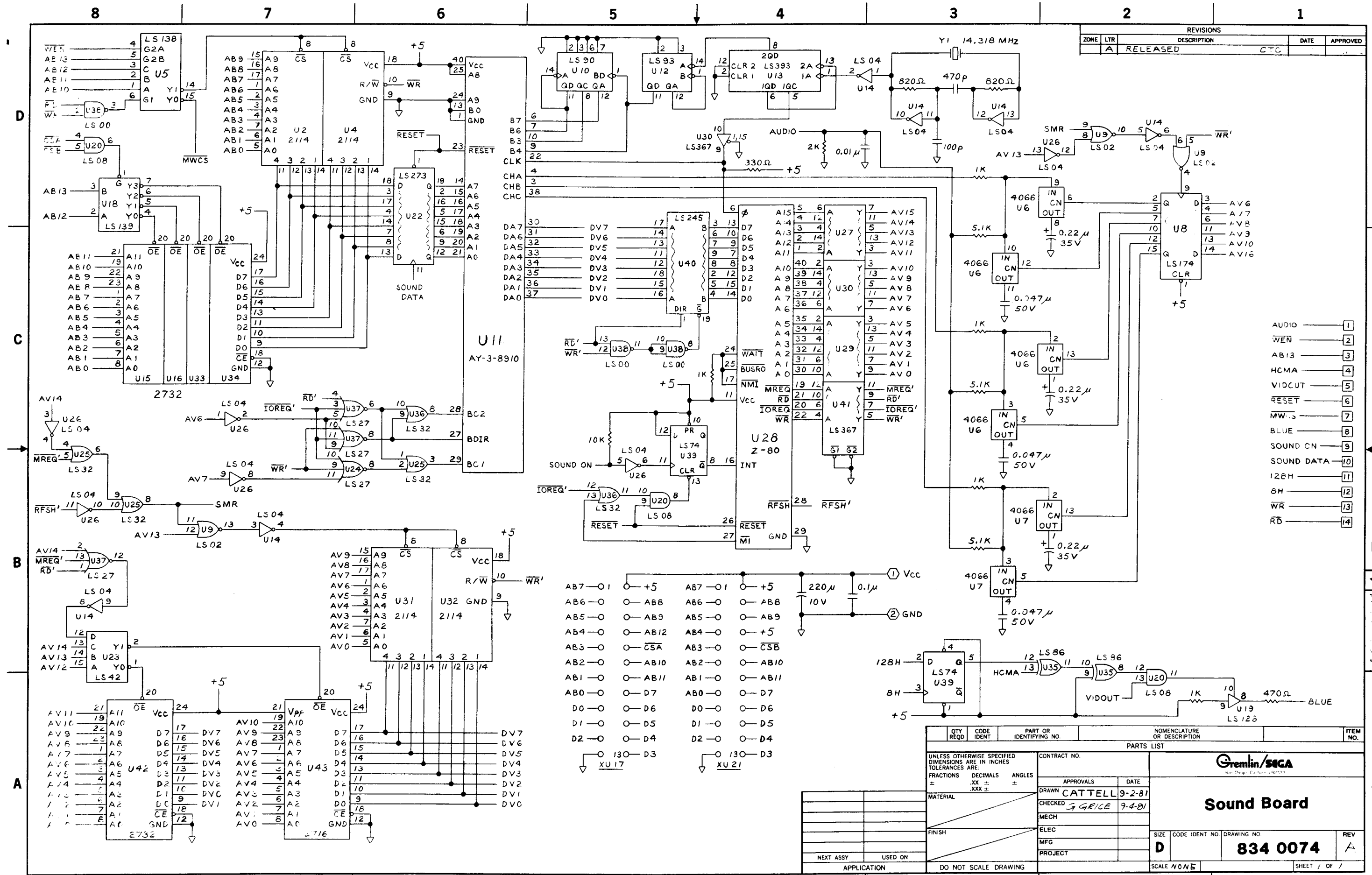

REVISIONS				
ZONE	LTR	DESCRIPTION	DATE	APPROVED
A	RELEASED			CTC

- AUDIO — 1
- WEN — 2
- AB13 — 3
- HCMA — 4
- VIDCUT — 5
- RESET — 6
- MWCS — 7
- BLUE — 8
- SOUND CN — 9
- SOUND DATA — 10
- 128H — 11
- 8H — 12
- WR — 13
- RD — 14

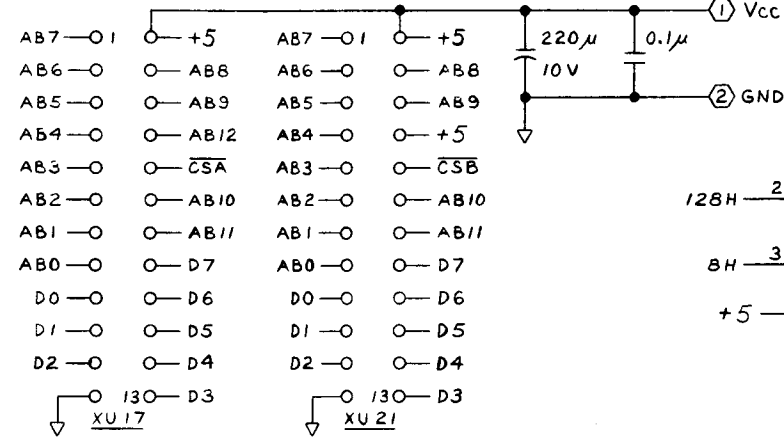

QTY REQD	CODE IDENT	PART OR IDENTIFYING NO.	NOMENCLATURE OR DESCRIPTION	ITEM NO.
PARTS LIST				
UNLESS OTHERWISE SPECIFIED DIMENSIONS ARE IN INCHES TOLERANCES ARE:		CONTRACT NO.		
FRACTIONS	DECIMALS	ANGLES	APPROVALS	
±	.XX ±	±	DATE	
	.XXX ±		DRAWN CATTELL 9-2-81	
MATERIAL		CHECKED GRICE 7-4-81		
FINISH		MECH		
NEXT ASSY USED ON		ELEC		
APPLICATION		MFG		
DO NOT SCALE DRAWING		PROJECT		
SCALE NONE		SIZE CODE IDENT NO. DRAWING NO.		
		D 834 0074		
		REV A		
		SHEET 1 OF 1		



MAIN I.C. BOARD SHT 2

REVISIONS			
ZONE	LTR	DESCRIPTION	DATE
		SEE SHT 1 FOR REVISIONS	J.F. 6-4-81

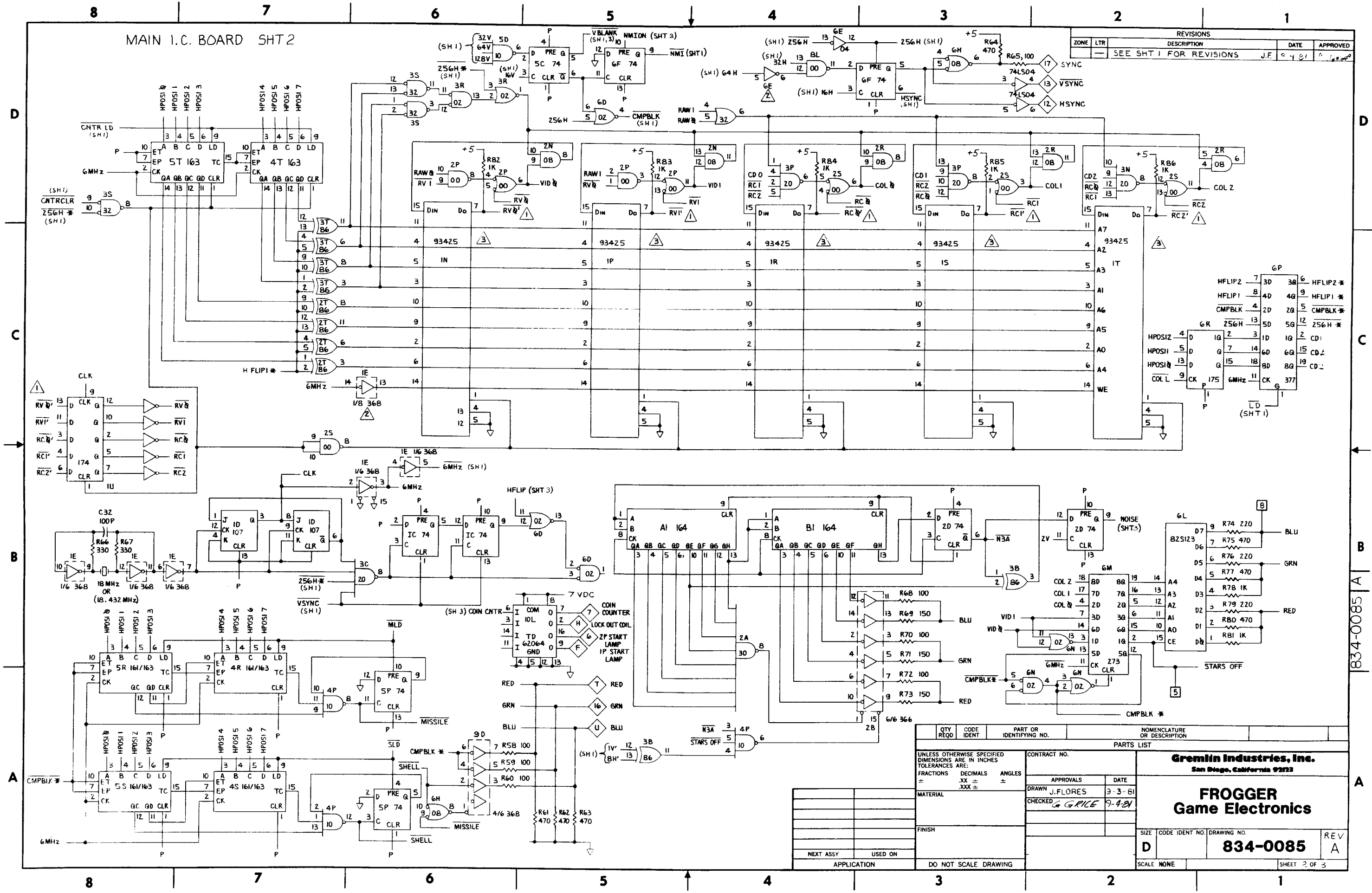

QTY REQD	CODE IDENT	PART OR IDENTIFYING NO.	NOMENCLATURE OR DESCRIPTION
PARTS LIST			
UNLESS OTHERWISE SPECIFIED DIMENSIONS ARE IN INCHES TOLERANCES ARE:		CONTRACT NO.	
FRACTIONS	DECIMALS	ANGLES	APPROVALS
± .XX ±	± .XXX ±	±	DATE
MATERIAL		DRAWN J.FLORES 3-3-81	
FINISH		CHECKED G GRICE 7-4-81	
NEXT ASSY		USED ON	
APPLICATION		DO NOT SCALE DRAWING	
SCALE NONE		SHEET 2 OF 3	

**Gremlin Industries, Inc.**  
San Diego, California 92123

**FROGGER**  
Game Electronics

SIZE CODE IDENT NO. DRAWING NO. **834-0085** REV **A**

834-0085 A

MAIN I.C. BOARD SHT 3

REVISIONS				
ZONE	LTR	DESCRIPTION	DATE	APPROVED
-	-	SEE SHT 1 FOR REVISIONS	J.F. 9-1-81	J.F.

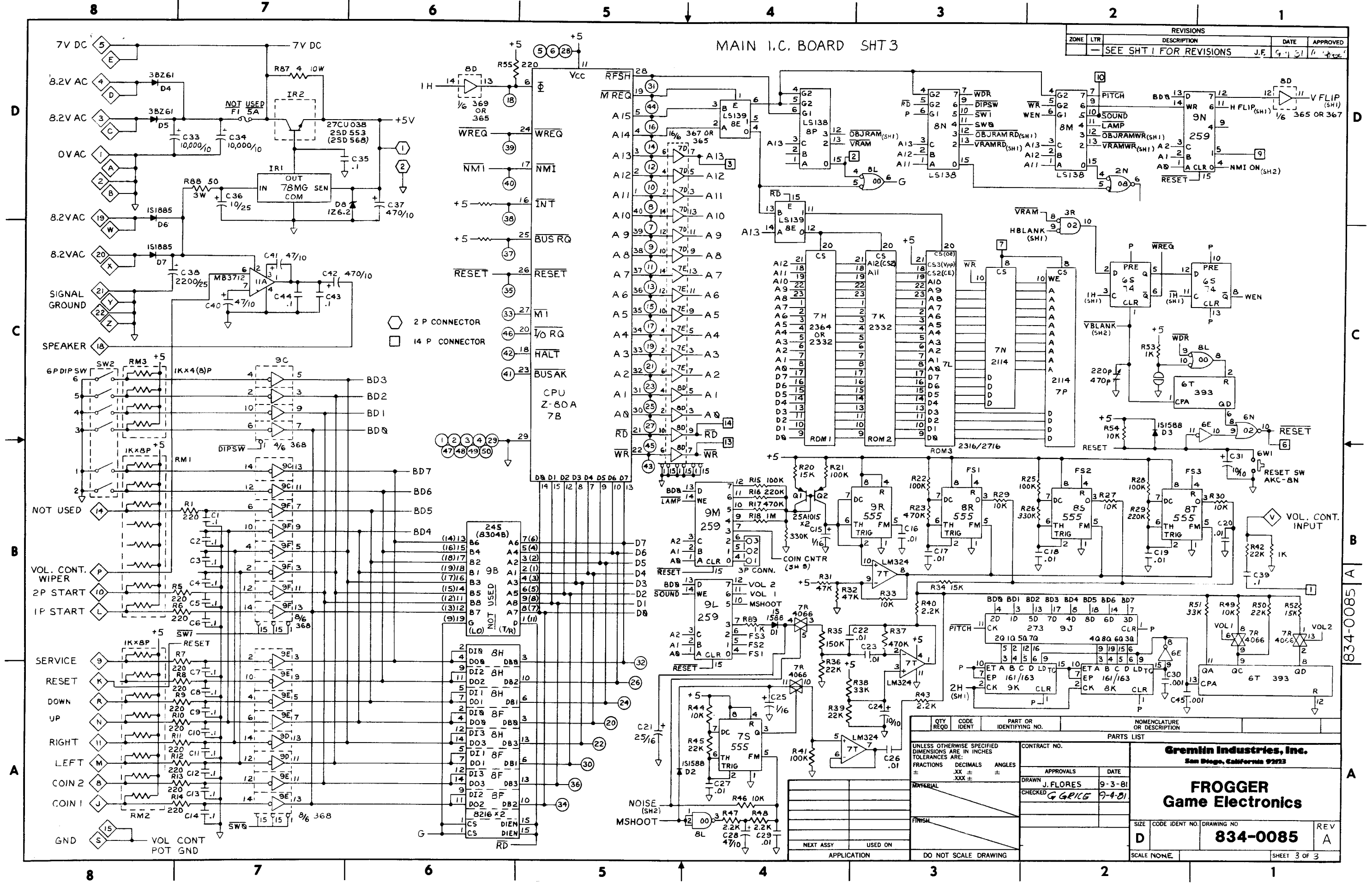

○ 2 P CONNECTOR  
 □ 14 P CONNECTOR

QTY REQD	CODE IDENT	PART OR IDENTIFYING NO.	NOMENCLATURE OR DESCRIPTION
PARTS LIST			
UNLESS OTHERWISE SPECIFIED DIMENSIONS ARE IN INCHES TOLERANCES ARE: FRACTIONS .XX ± DECIMALS .XXX ± ANGLES ±			
CONTRACT NO.		APPROVALS	
DRAWN J. FLORES		DATE 9-3-81	
CHECKED G. GRICE		DATE 7-4-81	
<b>Gremlin Industries, Inc.</b> San Diego, California 92123 <b>FROGGER</b> Game Electronics			
SIZE	CODE IDENT NO.	DRAWING NO.	REV
D		834-0085	A
SCALE NONE	SHEET 3 OF 3		