

# JET FIGHTER

TM-027

## Operation · Maintenance · Service Manual



ATARI INC. 14600 WINCHESTER BLVD, LOS GATOS, CA 95030 • (408) 374-2440 • TELEX 357-488

Copyright © 1975 by Atari, Inc.

## TABLE OF CONTENTS

<i>Subject</i>	<i>Page</i>		
I. INTRODUCTION	1	4.2 Energizing the Game	21
1.1 Physical Description of Game	1	4.2.1 Application of AC Power	21
1.2 Brief Description of Play	1	4.2.2 Check on Operation of Interlock Switch	21
II. SPECIFICATIONS	3	4.3 Game Structuring	22
2.1 General	3	4.3.1 Number of Players per Coin Option	22
2.2 Electrical	3	4.3.2 Length of Game Time Option	22
2.3 Environmental	3	4.4 Functional Check of Game Operation	23
2.4 Owner/Operator Options for Structuring of Play	3	V. MAINTENANCE AND ADJUSTMENTS	25
2.5 Accessories Available on Separate Order	3	5.1 Routine Maintenance	25
III. THEORY OF OPERATION	5	5.1.1 Cleaning	25
3.1 Functional Description of Game	5	5.1.2 Lubrication	25
3.2 General Information	5	5.2 Adjustments on TV Monitor	25
3.2.1 Energizing the Game	5	5.3 Adjustment of Speaker Volumes	26
3.2.2 TV Monitor	5	5.4 Adjustment of Explosion Sound	26
3.2.3 Picture on TV Screen	5	VI. TROUBLESHOOTING AND REPAIR	29
3.3 Game Sequence	5	6.1 General Procedure	29
3.3.1 Operating Modes	5	6.1.1 Identifying the Trouble Area	29
3.3.2 Attract Mode	5	6.1.2 Locating the Trouble Cause	29
3.3.3 Game Sequence in Play Mode	5	6.1.3 Correcting the Trouble Cause	29
3.3.4 Owner/Operator Options	8	6.1.4 Verifying Correct Game Operation	29
3.4 Detailed Technical Description of Operation	8	6.2 Test Equipment	30
3.4.1 General Comments	8	6.2.1 Basic Test Equipment	30
3.4.2 TV Synchronization Information and Blanking	8	6.2.2 Optional Test Equipment	31
3.4.3 Joystick Signals	11	6.3 Specific Troubleshooting Information	31
3.4.4 Jet Rotation	11	6.3.1 Antenna	31
3.4.5 Jet Horizontal and Vertical Motion Counters	11	6.3.2 TV Monitor	32
3.4.6 Plane Speed Codes	12	6.3.3 Coin Mechanisms	32
3.4.7 Generation of Load Signals	13	VII. SCHEMATICS, DRAWINGS, AND PARTS LISTS	35
3.4.8 Processing of ROM Video Information and Generation of Plane Video Signals	13		
3.4.9 Shell Speed Codes, Shell Motion Counters, and Shell Video	13		
3.4.10 Generation of Fire, Explosion, Hit and Blow-Up Signals	14		
3.4.11 Circuitry for 1-Player Game	15		
3.4.12 Score Counters and Score Video	16		
3.4.13 Game Sounds	17		
3.4.14 Video Summing	18		
3.4.15 Coin and Credit	18		
IV. INSTALLATION INSTRUCTIONS	21		
4.1 Unpacking Instructions	21		
4.1.1 Examination for Shipping Damage	21		
4.1.2 Mechanical Inspection	21		

# I. Introduction

---

## 1.1 PHYSICAL DESCRIPTION OF GAME

Atari's Jet Fighter is a video action game in which players pilot two airplanes across the sky in a fast-moving duel. The game is packaged in its own upright cabinet that rests directly on the floor. (Drawing number A002602 in Section VII of this manual shows an external view of the cabinet.) A 19-inch black-and-white TV monitor is mounted at the top front of the cabinet and players stand in front, facing the screen. A realistic sky effect is provided by the distinctively-styled cloud graphics that surround a square-shaped playfield on the TV screen.

The player-operated controls, mounted on a horizontal flat panel near the bottom of the TV screen, consist of two joysticks and two backlighted push button switches. (Drawing number A002624 shows an external view of this panel.) A coin assembly with two identical coin mechanisms is located below the player-operated controls. The mechanisms accept quarters only, and coins deposited in either one can initiate play. The Jet Fighter game features an owner/operator-adjustable option that permits on-site game structuring for either 1 player/coin or 2 players/coin. The cash box is located behind the access door to the coin assembly.

Two speakers mounted inside the cabinet, one on each side of the coin assembly, add to the game excitement by producing jet engine, gunfire and explosion sounds during play.

## 1.2 BRIEF DESCRIPTION OF PLAY

In the Jet Fighter game two delta-winged fighters—one white plane and one black plane—fly across the TV screen, each plane trying to hit the other with its shells. Jet Fighter can be played by either one or two players: with one player the white plane is piloted by the player and the black plane by the game's internal computer, and with two players each plane is piloted by a player. The player controls his plane's speed and direction by moving his front panel joystick lever, and fires a shell by depressing a push button on top of that lever.

The player's objective is to fire as many shells as possible into the opponent's plane, while at the same time maneuvering his own plane to avoid shells fired by the opponent. After coin deposit the duel begins when a start button is depressed. A plane can fire only one shell at a time and the shell explodes when it hits the opponent's plane, or when it has traveled over a distance equal to about three-fourths of the width of the playfield. If a player's shell hits the opponent's plane, that plane explodes and spins around very rapidly. After a few seconds the hit plane recovers and flies off in some randomly chosen direction, and the duel resumes.

One point is added to a player's score each time the shell from his plane hits the other plane. The accumulated scores for both planes are displayed continuously on the TV screen.

Along with this video action, the following sounds are heard during play. The speaker on the left side of the cabinet produces the black plane's engine roar, and the speaker on the right produces the white plane's roar, continuously during play. The engine sound is at low pitch when the plane's speed is slow, at medium pitch when speed is medium, and at high pitch when speed is fast. In addition, both speakers produce a blast noise whenever either plane fires a shell and whenever any shell explodes by itself. An explosion noise, twice as loud and twice as long as the previous noise, is produced by both speakers whenever a shell hits a plane.

Play ends when the game timer elapses (the Jet Fighter game features an owner/operator-adjustable option that permits on-site structuring of the game time). At this point, the planes continue to fly, but maintain the speeds and directions they held at the moment the game ended. The final scores continue to be displayed, but there is no sound and the joysticks are inoperative. A player depositing a coin will initiate a new play sequence.

# II. Specifications

## 2.1 GENERAL

Cabinet Dimensions: Height 60¼ inches, Width 25¼ inches, Depth 23¼ inches  
Cabinet Weight: 227 lbs.  
TV Monitor: Motorola XM501, black and white, with 19-inch screen.  
Coin Mechanisms: Two identical mechanisms that accept quarters only; coins deposited in either one can initiate play.  
Cash Box: Removable, located behind locked access door to coin mechanism assembly.  
Power Cord: Approximately 6 ft. long, extending from rear of cabinet and having grounded three-prong plug for conventional wall outlets.

## 2.2 ELECTRICAL

Power Requirement: Uses conventional wall outlet providing 60-cycle AC (60-Hz, single-phase) at 110 volts; power consumption rated at 120 watts.  
Fusing: All fuses located inside cabinet; TV monitor has two 1-amp fuses and remainder of game is protected by a single 1.25-amp fuse.  
Power Interrupt Switch: This is a safety switch located inside the game cabinet. It interrupts AC power to the game whenever the rear panel service access door is unlocked and opened.

## 2.3 ENVIRONMENTAL

Operating and Storage Temperature Range: from 32°F to 120°F (ambient temperature)  
Relative Humidity: from 0% to 80% without condensation

## 2.4 OWNER/OPERATOR OPTIONS FOR STRUCTURING OF PLAY

- Choice of 1 player per coin or 2 players per coin
- Length of game time: adjustable from about 45 seconds to about 140 seconds.

## 2.5 ACCESSORIES AVAILABLE ON SEPARATE ORDER

Video Probe: order from Atari  
Universal Test Fixture: order from Atari, catalog no. TF101

# III. Theory of Operation

## 3.1 FUNCTIONAL DESCRIPTION OF GAME

The block diagram in Figure 3-1 shows the major functional parts of the Jet Fighter game and how they are interconnected. The TV monitor is a self-contained unit housed in its own chassis inside the game cabinet. In the game control circuitry the synchronization, blanking and picture information are combined and then sent on a single composite video signal to the monitor. The game's sounds, however, are produced by two speakers which are separate from and not connected to the monitor.

The joystick on the left side of the cabinet provides player controls for the black plane, and the speaker on the left side produces the black plane's engine roar and the other game sounds. The joystick and speaker on the right operate in a similar way for the white plane.

## 3.2 GENERAL INFORMATION

The general information about Jet Fighter given here provides a background for understanding the Installation Instructions in Section IV of this manual, and the descriptions of game operation in paragraphs 3.3 and 3.4.

**3.2.1 ENERGIZING THE GAME:** The Jet Fighter game does not have an external "power on" switch. Instead the game is energized as soon as the power cord is plugged into an active AC wall outlet. This outlet must provide the AC power listed in the Specifications (Section II of this manual).

**3.2.2 TV MONITOR:** The game's TV monitor is a self-contained transistorized television monitor supplied to Atari by Motorola. Because the composite video signal supplied to the monitor by the game control circuitry differs in certain important respects from the signal derived from commercial TV broadcasts, the picture appearing on the screen is unlike that of a home TV set and the monitor does not produce any sound.

**3.2.3 PICTURE ON TV SCREEN:** The game's composite video signal is constructed to produce only three video levels—white, medium white, and black—instead of the more or less continuous shades of gray (between the extremes of black and white) seen on a home TV screen. Also the horizontal scan lines on the screen will be more noticeable than those on a home TV. A commercial TV broadcast signal produces a picture having 525 lines, with interlace, from top to bottom on a TV screen. But the game's composite video signal contains synchronization information that produces only about half as many lines, without interlace, on the game's screen.

Video levels of the images shown in the TV picture are as follows: the background "sky" is medium white level; one plane, shell, and score are at the white video level; the other plane, shell, and score are at the black video level.

As soon as a plane or a shell travels off any edge of the TV screen, it immediately reappears at the opposite edge and starts across the screen again, retracing its previous flight path until commanded to change. This "wrap-around" effect makes it more challenging for the player to follow the flight paths and also makes it possible for a plane to fire a shell at a pursuing plane.

A plane cannot fire a new shell until after the previous shell has exploded, and a plane cannot be hit by its own shell. Planes and shells can pass through the score display regions on the screen without any interaction with the numerals, and there is also no interaction should the two planes (or two shells) touch or overlap one another during flight. Planes are never allowed to crash.

## 3.3 GAME SEQUENCE

**3.3.1 OPERATING MODES:** During use the Jet Fighter game can be described as operating in either of two modes, attract or play. Plugging the power cord into an active AC outlet energizes the game and it starts out in the attract mode. The game remains in the attract mode until a player deposits a coin, the coin clears the coin mechanism, and the appropriate start button is pushed, at which point a signal derived from the start button causes the game to go into the play mode. The game remains in the play mode until the game timer elapses, at which time the game reverts back to the attract mode.

**3.3.2 ATTRACT MODE:** During this mode the two planes fly across the TV screen, each retracing the same flight path over and over again, but do not fire any shells. The speakers do not produce any sound and all player controls are inoperative. Just after the game is energized, each plane flies along its own randomly-chosen, straight-line direction, and some random numerals will be showing in the score display regions at the top of the screen. After completion of a previous play mode, each plane will be flying in a straight-line direction derived from its heading at the final moment of the play mode, and the final scores from the play mode will remain showing. Both planes fly at medium speed during the attract mode.

**3.3.3 GAME SEQUENCE IN PLAY MODE:** A player enables the game to change over from the attract to the play mode when depositing a coin that clears either coin mechanism. A signal sent from the mechanism then causes the game control circuitry to respond as follows: If the game is structured for 1 player/coin, the right-hand push button switch (engraved with the words ONE PLAYER

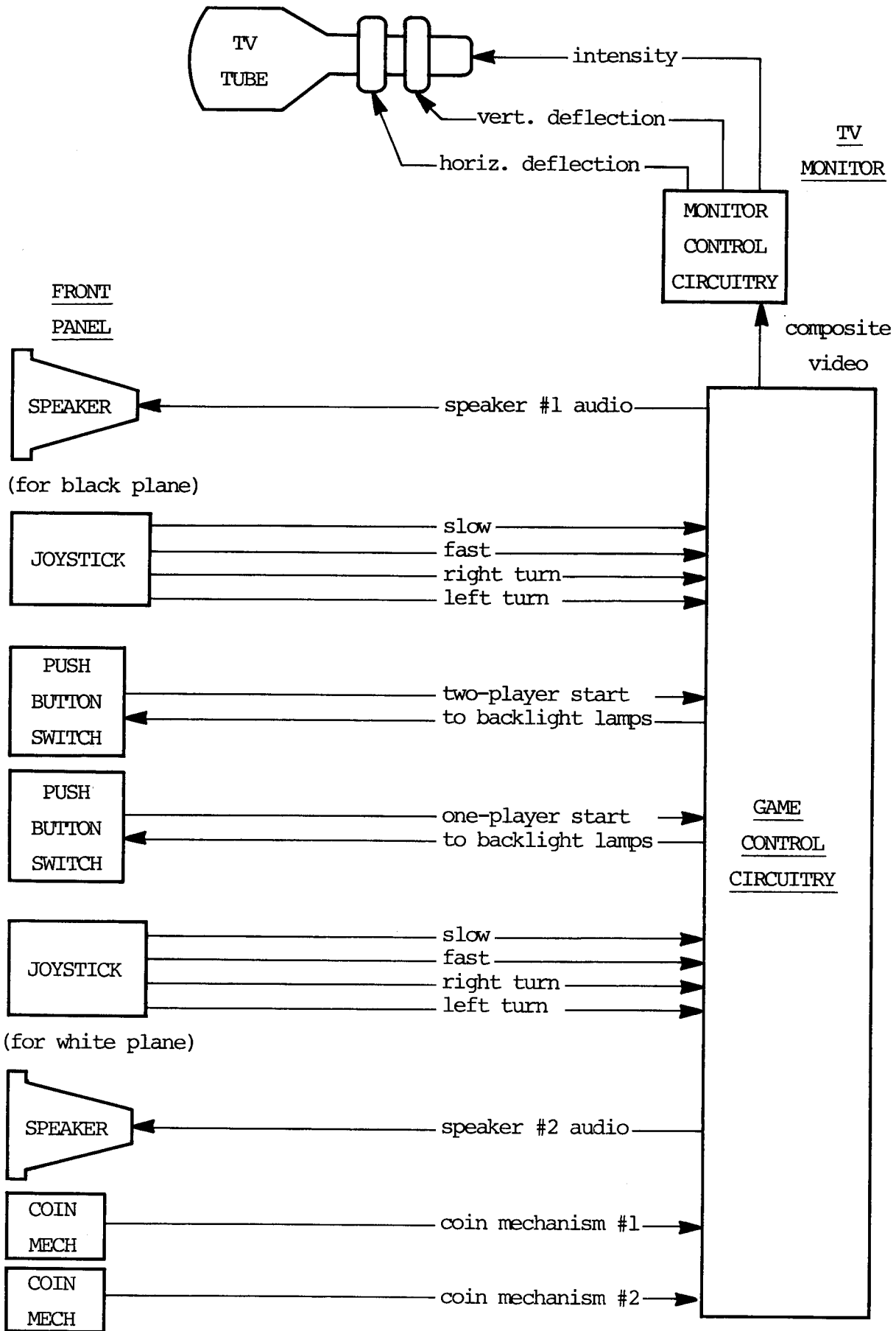

Figure 3-1 Block Diagram of Jet Fighter Game

START) will light up. Under this structuring, a second coin must be deposited if two players wish to play. When this second coin clears, the game control circuitry responds by extinguishing the backlighting on the right-hand switch and lighting up the left-hand switch (engraved with the words TWO PLAYER START). If the game is structured for 2 players/coin, both push button switches will light up as soon as one coin clears the coin mechanism.

To begin the duel, the player must now depress the appropriate lighted push-button switch—the right-hand switch for a one-player game and the left-hand switch for a two-player game. After he does this, the game control circuitry responds as follows:

- (a) The appropriate switch backlighting is removed (in the 2 players/coin structure).
- (b) Both speakers begin to produce the game sounds.
- (c) On the TV screen the scores are both reset to zero (numerals “0” are displayed), and plane motion is changed over to parallel paths moving from the bottom of the screen toward the score numerals at the top, with the black plane at the left and the white plane at the right.
- (d) In a two-player game each plane is allowed to obey the joystick commands. In a one-player game, only the white plane is allowed to obey its joystick commands; the left joystick remains inoperative and the black plane begins to receive commands from the game’s internal computer.

During a duel the player uses the joystick to control his plane as follows:

- (a) *Plane speed.* Pulling the joystick lever all the way back causes the plane to fly at its slow speed; pushing the lever all the way forward commands the fast speed; and leaving the lever in the mid-way position commands the medium speed. The pitch of the engine roar sound produced by the plane’s speaker will also change each time the lever position is changed.
- (b) *Plane direction.* Moving the lever over all the way to the left causes the plane to begin turning in a counterclockwise direction on the TV screen. Moving the lever to the right causes the plane to begin turning in a clockwise direction on the TV screen. This turning will appear to be very smooth, closely resembling the slipping motion of an actual jet fighter plane while making a turn—due to a quarter-second delay in the plane’s direction of motion with respect to the actual video displayed. The turn continues until the player moves the lever back to the central position, at which time the plane’s flight path changes to a straight line along that particular angular orienta-

tion.

- (c) *Firing shells.* The push-button switch mounted on top of the joystick lever serves as a trigger control for firing shells. A plane can only fire one shell at a time, and the previous shell must explode—either by hitting the opponent’s plane or by traveling to the end of its “range” (three-fourths of the width of the TV screen)—before a new shell can be fired. Shells always travel in straight lines and at twice the speed of the plane firing the shell. A player has a choice of either pressing and releasing the trigger each time he wants to fire a shell, or of continuously holding down the trigger switch so that a new shell will be fired automatically as soon as the previous shell has exploded. However, he will have more control over the time of firing if he releases the trigger each time. There is no limit on the number of shells that can be fired. A blast noise is produced by both speakers whenever either plane fires a shell and whenever any shell explodes.

Each time a shell hits a plane the game control circuitry responds as follows:

- (a) Both speakers produce an explosion noise that is twice as loud and twice as long as the explosion caused by firing a shell or by a shell reaching the end of its range.
- (b) The score displayed for the plane that fired the shell will be increased by one. If 15, the maximum value, has been showing, the score will be “wrapped around” to zero.
- (c) The video for the fired-upon plane will momentarily “invert.” If, for example, the white plane is hit, it will change to black video enclosed in a small white video rectangle. Also the plane will immediately begin to rotate very rapidly. However, this plane continues to be able to fire a shell during this time, provided that its previous shell has exploded. This sequence lasts for one second, after which the plane’s video returns to normal and it starts to fly away in a straight line along some random direction.

In a one-player game the black plane, under control of the internal computer, automatically tracks the player’s white plane. The black plane can automatically fire at the white plane whenever it crosses in front of the black plane’s line of fire. But, like the white plane, the black plane can still fire only one shell at a time.

The duel continues as described until three-fourths of the game time has elapsed, at which time the numerals in both score displays begin to blink. The numerals continue to blink for the remaining one-fourth of the game time,

warning players that play is about to end. When all the game time has elapsed, the game reverts to the attract mode. At that point the blinking stops and the final scores remain showing, each plane continues to fly along its own straight-line path determined by the direction it held at the moment the play ended, and both speakers cease to produce sounds. Both planes are made to fly at medium speed.

**3.3.4 OWNER/OPERATOR OPTIONS:** The Jet Fighter game features two options that allow the owner/operator to structure the game play—that is, change some of the rules or alter the game time—at the game site. Both of these options are simple manual adjustments.

The 1 player/coin—2 players/coin option consists of a two-position slide-type switch mounted on the printed circuit board inside the game cabinet. When the slide is set in one position, the game is structured for one player for one coin, two players for two coins. When the slide is in the other position, structuring is such that, upon deposit of one coin, the choice of a one- or two-player game is left up to the player. Para. 4.3.1 in Section IV of this manual gives instructions for making this adjustment.

The second option, length of game time, consists of a potentiometer (Trimpot) also mounted on the PCB inside the cabinet. A stud projecting from the top of the potentiometer body can be moved manually so that game time will increase or decrease within the minimum and maximum limits listed in the Specifications in Section II. Para. 4.3.2 gives instructions for making this adjustment.

## 3.4 DETAILED TECHNICAL DESCRIPTION OF OPERATION

**3.4.1 GENERAL COMMENTS:** This paragraph 3.4 gives a component-level technical description of the game's electronic circuitry. The following drawings supplement the text included here. Drawing number 004254 (in four sheets) is a schematic diagram of the circuitry located on the printed circuit board; drawing number A004254 is an assembly diagram showing locations of components mounted on the PCB; and drawing number 004279 is a schematic of the harness wiring. These drawings, along with a schematic diagram of the TV monitor's circuitry, are included in Section VII of this manual.

On the PCB and on its schematic each integrated circuit device location is identified by a column letter designation (A thru R) and by a row number designation (1 thru 10).

On the PCB schematic the symbol "P" (which appears at various inputs to logic gates and other integrated circuits) indicates a connection to +5 volts through a pull-up resistor.

On all documentation the black plane is referred to as "JET 1" and the white plane as "JET 2." Also, the speaker on the left side of the cabinet (the black plane's speaker) is referred to as "SPEAKER 1," and the speaker on the right side (the white plane's speaker) as "SPEAKER 2."

**3.4.2 TV SYNCHRONIZATION INFORMATION AND BLANKING (REFER TO PCB SCHEMATIC, SHEET 1, ZONES D 5 THROUGH 8):** The 12-MHz crystal-controlled oscillator's output at gate R1 pin 6 is applied to flip-flop D2, which divides down the frequency by 2. The CLOCK signal produced at D2 pin 15 drives the horizontal sync chain formed by flip-flop F1 and counters A2 and B2. This sync chain divides down the frequency of the CLOCK signal by 384. The timing diagram in Figure 3-2 illustrates the dividing-down of the 12-MHz signal to produce the CLOCK signal, and the dividing-down of the CLOCK signal (in the first stage of the sync chain) to produce the 1H signal.

Certain outputs from the sync chain applied to flip-flop B3 produce the H SYNC signal at B3 pin 8 and H BLANK at B3 pin 6. The H SYNC signal serves as the timing basis for the horizontal synchronization information contained in the composite video signal sent to the TV monitor. The line scan rate (horizontal sweep frequency) is 15.75 KHz. The H BLANK signal sets the *width* of the playfield on the TV screen at 252 clock pulses (see Figure 3-3).

The  $\overline{\text{H SYNC}}$  signal drives the vertical sync chain formed by flip-flop D3 and counters B4 and C4. This sync chain divides down by 272; certain of its outputs applied to flip-flop B6 produce the V SYNC signal at B6 pin 6 and V BLANK at B6 pin 8. The V SYNC signal serves as the basis for the vertical synchronization information sent to the TV monitor; the frame rate or vertical sweep frequency is about 58 Hz. The V BLANK signal sets the *height* of the playfield on the TV screen at 252 horizontal scan lines (see Figure 3-4). In other words, the electron beam inside the TV tube makes 252 horizontal line scans during its travel from the top left corner of the TV screen down to the lower right corner during each picture frame.

The  $\overline{\text{V SYNC}}$  signal, generated once each frame, is applied at C8 pin 11 to drive the frame counter formed by flip-flop C8 and counter P3. The frame signals 1F, 2F, etc., produced by the frame counter are used in the jet and shell motion circuits.



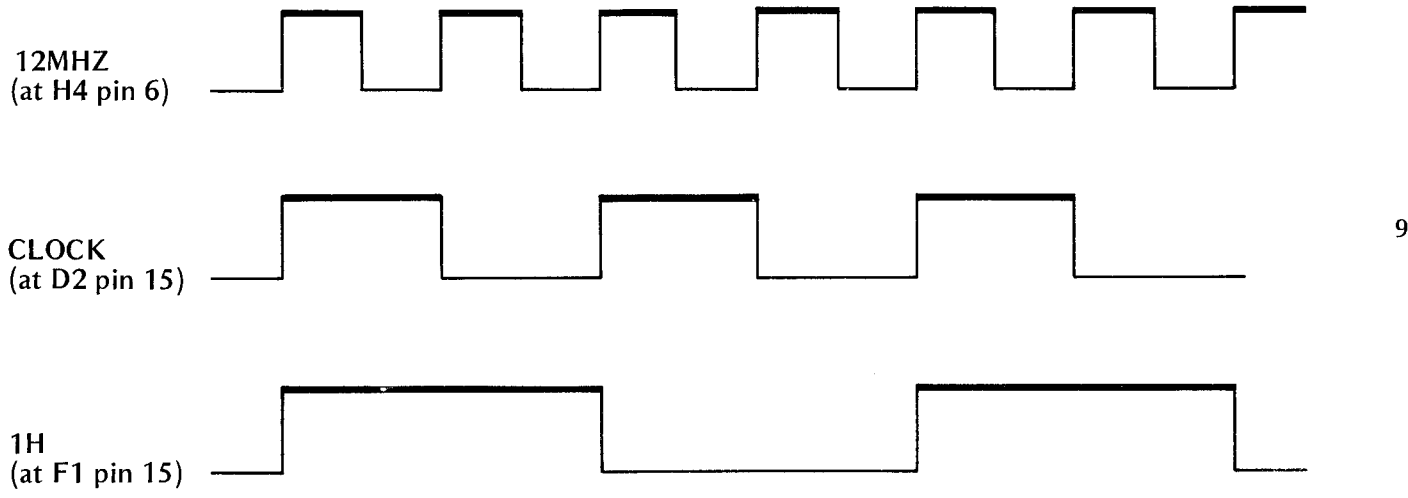

Figure 3-2 Horizontal Sync Chain Timing Diagram

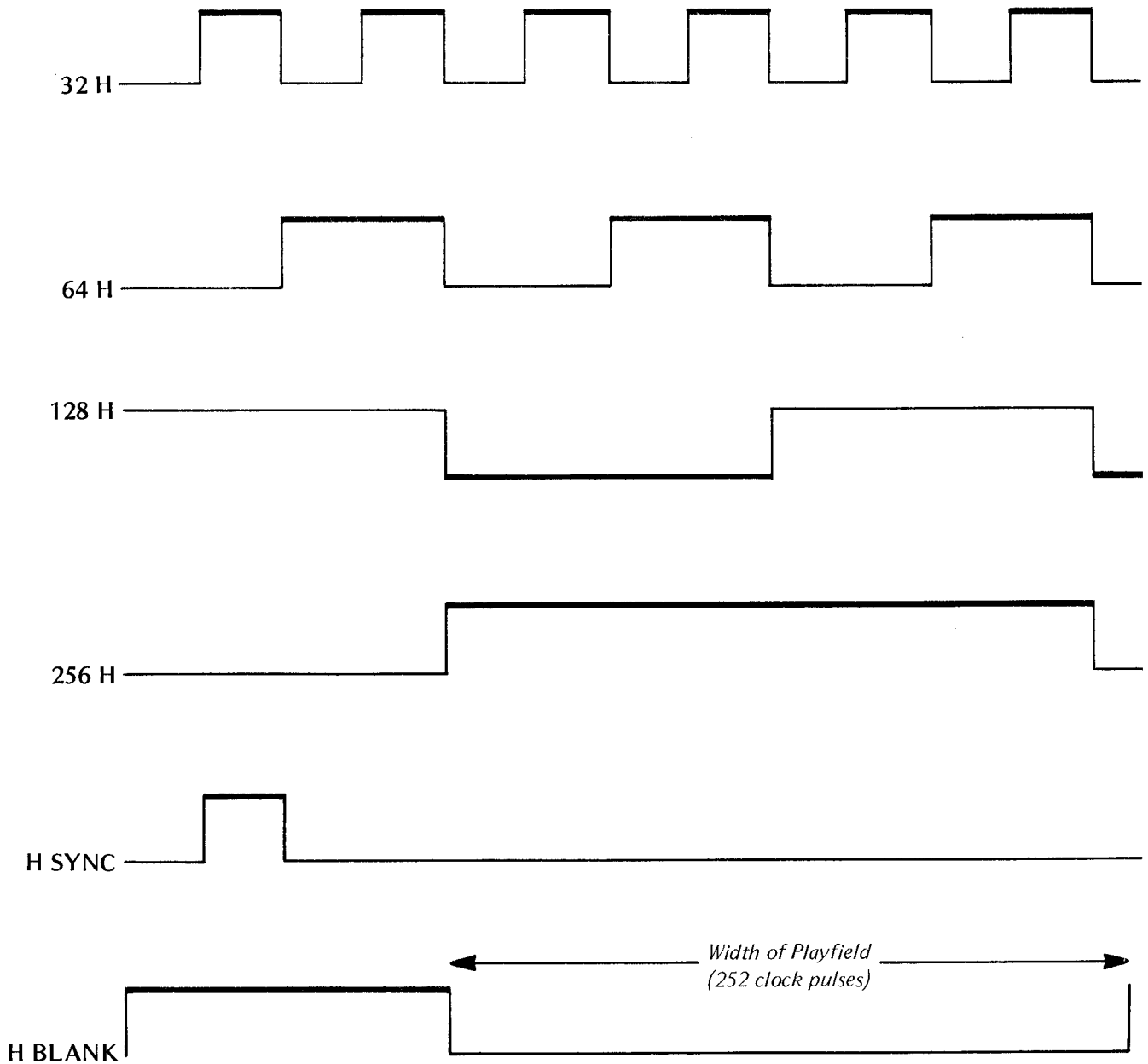

Figure 3-3 Horizontal Sync Chain Timing Diagram

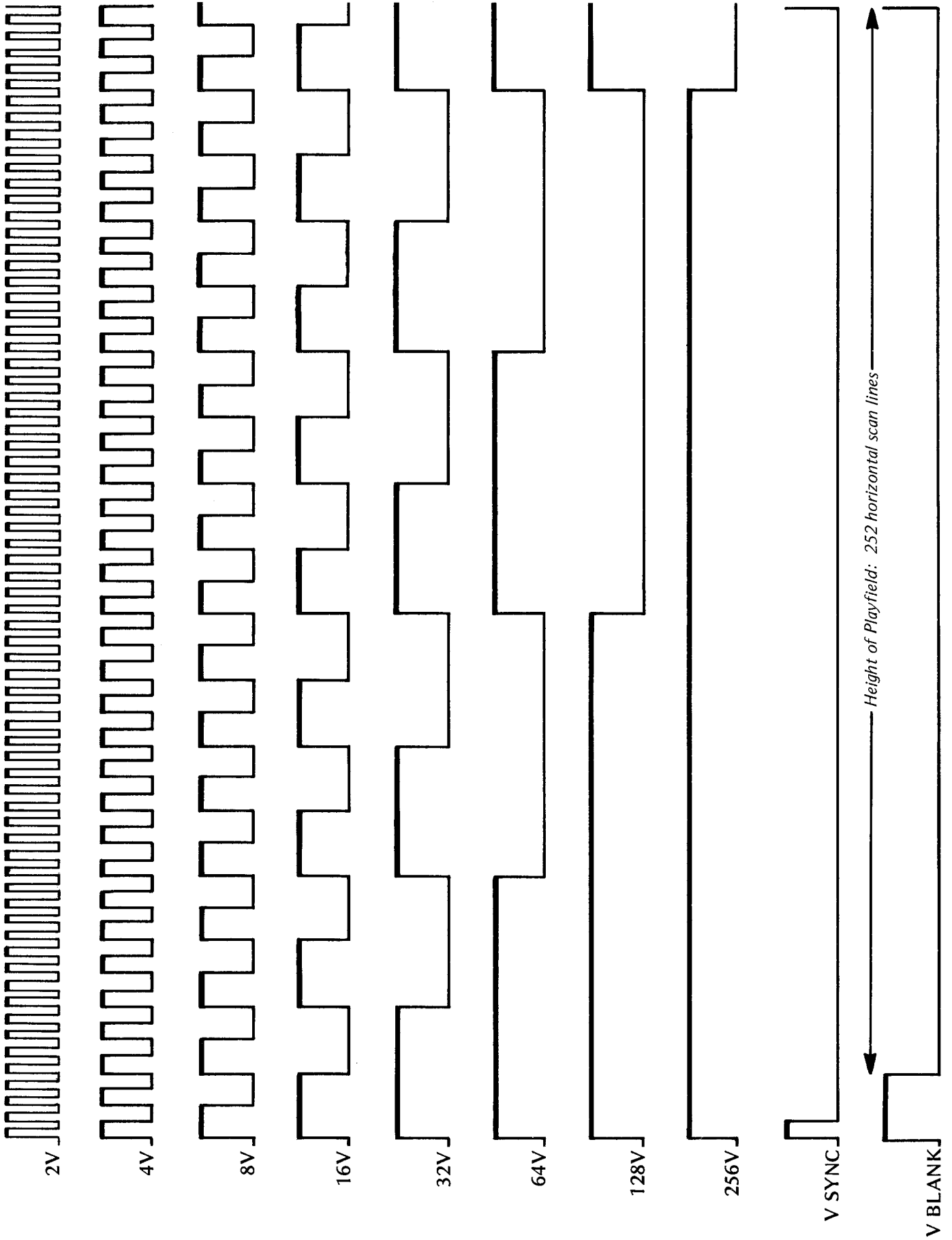

Figure 3-4 Vertical Sync Chain Timing Diagram

**3.4.3 JOYSTICK SIGNALS (SHEET 3, ZONES C, D 5 THROUGH 8):** The harness schematic, drawing number 004279, shows the connections made to the five switches—two for direction, two for speed, and one to fire a shell—mounted on the underside of each joystick. The “common” contacts of all switches are tied to ground, and the normally-open contacts are each brought separately to the PCB edge connector (at pins 8 thru 13, K, M, N and P). When a player’s movement of the joystick lever causes a switch to close, that switch’s edge connector pin is forced to ground.

The type-9322 device in location J8 gates signals from Joystick 1 (the one on the left, for the black plane) and corresponding signals generated by the game’s internal computer. The binary state of the 1 PLAY signal applied at J8 pin 1 will determine whether Jet 1 (the black plane) will be controlled by the game’s internal computer (a 1-player game), or by commands from Joystick 1 (a 2-player game).

The type-74153 dual 4-input multiplexer device in location H8 provides plane speed control by examining the SLOW and FAST joystick signals once every frame, and producing a GO signal that determines how often a plane will move. At slow speed the plane makes a “unit” move during 2 out of every 4 frames; at medium speed during 3 out of every 4; and at fast speed during every frame. The timing diagram in Figure 3-5 illustrates the speed control for Jet 2 (the white plane). Paragraph 3.4.6 describes how these GO signals are used to generate the jet speed codes.

**3.4.4 JET ROTATION (SHEET 3, ZONES C, C 4 THROUGH 6):** The turning motion of each plane, either toward the left (counterclockwise rotation) or toward the right (clockwise rotation), is under control of a rotation counter. The type-74193 counter in location H6 plus part of flip-flop F6 form the Jet 1 rotation counter for the black plane. The type-74193 counter in J7 plus part of flip-flop F6 form the Jet 2 rotation counter for the white plane. Each rotation counter is a 5-bit, up/down type of binary counter, and each is driven by the identically-designed decoding logic implemented by gates K8, F7 and H7. This decoding logic determines whether or not the respective plane is to be turned, and if so, whether toward the right (via count-up inputs H6 pin 5 and J7 pin 5) or toward the left (count-down inputs H6 pin 4 and J7 pin 4). Note the joystick signals LEFT 1, RIGHT 1 and LEFT 2, RIGHT 2 applied as inputs to the decoding logic.

Each rotation counter produces a 5-bit rotation code—the J1R0 thru J1R4 signals for the black plane and the J2R0 thru J2R4 signals for the white plane. This 5-bit code is used to describe which of the plane’s 32 discrete angular orientations will be displayed on the TV screen during a given frame.

**3.4.5 JET HORIZONTAL AND VERTICAL MOTION COUNTERS (SHEET 2, ZONES A, B, C, D 6 THROUGH 8):** The actual movement of the two planes across the TV screen is under control of two identically designed pairs of motion counters—one pair of horizontal motion counters

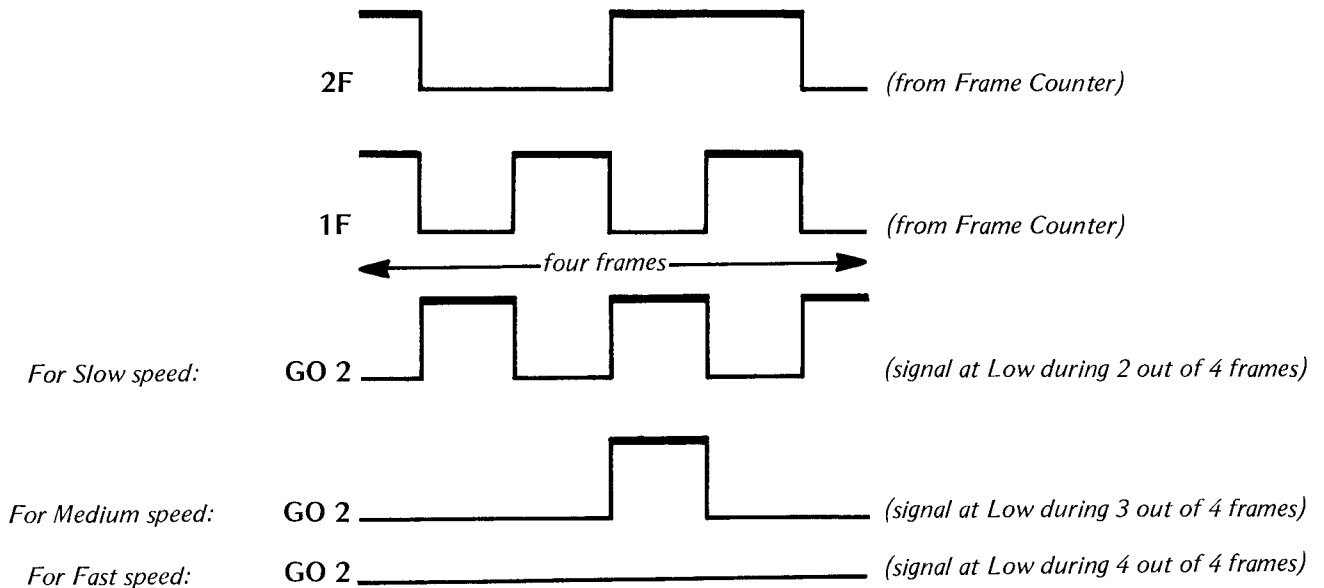

Figure 3-5 Timing Diagram Showing Speed Control For Jet 2

and one pair of vertical motion counters. The type-9316 counters in locations P7 and P6 form the Jet 1 horizontal motion counter, and the type-9316 counters in N6 and N5 form the Jet 1 vertical motion counter. Similarly, the type-9316 counters in locations L7 and L6 form the Jet 2 horizontal motion counter, and the type-9316 counters in M6 and M5 form the Jet 2 vertical motion counter.

These pairs of motion counters count in parallel with the horizontal and vertical sync chains (see paragraph 3.4.2). For example, in order to move the white plane vertically—either up or down—on the TV screen, that plane's vertical motion counter, M6 and M5, is forced either to count short (causing upward plane motion) or to count long (causing downward plane motion), with respect to the vertical sync counter. Similarly, to move the white plane horizontally—either towards the left or to the right—the horizontal motion counter (L7 and L6) is forced to either count short (causing motion towards the left), or to count long (causing motion towards the right) with respect to the horizontal sync counter.

For the horizontal motion counters the long or short count is limited to one line per frame by gating (at gate N7) of the V RESET signal with the plane's 2-bit horizontal speed code (J1C0 and J1C1 for the black plane, and J2C0 and J2C1 for the white plane). Generation of the plane speed codes is described in paragraph 3.4.6. The H CLOCK signal, obtained by gating out the basic system clock (6 MHz rate) during H BLANK time, clocks each horizontal motion counter and limits the number of clocking pulses to 252 per horizontal line scan across the TV screen.

In the vertical motion counters the long or short count is also limited to one count per frame. The V CLOCK signal, which is representative of the line rate (H SYNC) but has been gated out during V BLANK time, is applied to both vertical motion counters and limits their vertical motion clocking to 252 pulses per frame. The plane's 2-bit vertical speed code (J1C2 and J1C3 for the black plane, and J2C2 and J2C3 for the white plane) is applied directly to the preset inputs of the first stage of each vertical motion counter (counter N6 for the black plane and M6 for the white plane).

**3.4.6 PLANE SPEED CODES (SHEET 1, ZONES A, B4 THROUGH 6 FOR JET 1 AND ZONES B, C 1 THROUGH 3 FOR JET 2):** The four signals J1C0 through J1C3 produced by the 64-bit RAM (random-access memory) device in location N8 contain speed code information for the black plane. Similarly, the four signals J2C0 through J2C3 produced by the RAM in location M8 contain this information for the white plane. During each frame that a plane's  $\overline{GO}$  signal— $\overline{GO} 1$  for the black plane and  $\overline{GO} 2$  for the white plane—is low, the plane's horizontal and vertical motion counters are made to move in the direction specified by its

respective speed code signals. Paragraph 3.4.3 describes the generation of the  $\overline{GO}$  signals. Following is a description of the circuitry that drives the two RAMs.

Type-7493 4-bit binary counters, in location N9 for Jet 1 and location M9 for Jet 2, address each RAM. Each counter is clocked by the same signal that determines the read/write status of its RAM. Type-74153 dual 4-input multiplexers, in location M4 for Jet 1 and in location L4 for Jet 2, produce the data inputs to the RAMs. The inputs to both multiplexers are the set of eight signals ROM 0 through ROM 7, (ROM 0 through ROM 3 for vertical data and ROM 4 through ROM 7 for horizontal data).

The ROM 0 through ROM 7 signals come from 4000 bits of ROM (read-only memory) capacity provided by either a *single* 4K ROM in location F5, or by a *pair* of 2K ROM devices in location K5 and K6. The game's printed circuit board is laid out in such a way that during assembly at the factory a choice can be made whether to install a single 4K ROM device or to install a pair of 2K ROM devices. Permanently stored in the 4000 bits of ROM capacity are 32 unique categories of information—one for each of the planes' 32 angular orientations. Each category contains plane video information, as well as plane and shell speed code data associated with that particular rotation.

The two type-9322 multiplexer devices in locations J6 and K6 produce the signals that address the ROM or ROMs. These addressing signals represent the plane's present rotation and the line information. The input signals to multiplexers J6 and K6 are: J1R0 through J1R4 and J2R0 through J2R4 (coming from the rotation counters, para. 3.4.4), and J1V1 through J1V4 and J2V1 through J2V4 (coming from the vertical motion counters, paragraph 3.4.5).

The dual flip-flop devices in locations N4 and P4 form 2-bit Grey code counters. For the black plane (Jet 1) Grey code counter N4 selects which of the four vertical ROM data signals (ROM 0 through ROM 3) and which of the four horizontal ROM data signals (ROM 4 through ROM 7) that the type-74153 multiplexer M4 will look at. Likewise, for the white plane (Jet 2) Grey code counter P4 selects which of the four vertical and which of the four horizontal ROM data signals that multiplexer L4 will look at. These respective ROM outputs determine, out of every four frames that the plane is moving, whether the plane is to move horizontally, vertically or both. However, these eight ROM signals only designate *how often* a respective plane moves vertically or horizontally on the TV screen; the *direction* of a plane's movement vertically or horizontally is determined by certain signals generated by the rotation counters (see para. 3.4.4). For example, the direction in which the white plane moves *vertically* on the TV screen is determined by the condition of the J2R4 + J2R3 signal (at gate P8 pin

10); the direction of movement *horizontally* is determined by the  $\overline{J2R4}$  signal (at gate P8 pin 13).

**3.4.7 GENERATION OF LOAD SIGNALS (SHEET 1, ZONE A, B 2 THROUGH 4):** Because the game's 4000 bits of ROM storage has been permanently programmed with three types of data (plane pictures, plane speed, and shell speed) all three types will appear on the ROM outputs (the signals ROM 0 thru ROM 7). In order to separate types of data during read-out, the four timing signals  $\overline{LOAD\ 0}$  thru  $\overline{LOAD\ 3}$  are produced by gate C1. These LOAD signals are used to time the loading of plane and shell speed data as follows:  $\overline{LOAD\ 1}$  at C1 pin 8 for Jet 1 (the black plane),  $\overline{LOAD\ 3}$  at C1 pin 3 for Jet 2 (the white plane),  $\overline{LOAD\ 0}$  at C1 pin 11 for Shell 1 (black plane's shell), and  $\overline{LOAD\ 2}$  at C1 pin 6 for Shell 2 (white plane's shell).  $\overline{LOAD\ 0}$  through  $\overline{LOAD\ 3}$  are also used to time the loading of plane video information:  $\overline{LOAD\ 0}$  and  $\overline{LOAD\ 1}$  for Jet 1, and  $\overline{LOAD\ 2}$  and  $\overline{LOAD\ 3}$  for Jet 2.

The inputs to Gate C1 are provided by logic circuitry that is driven by the  $\overline{H\ SYNC}$  and certain other timing signals generated in the horizontal sync chain (see paragraph 3.4.2). This circuitry is also driven by the plane horizontal window signals J1 H WINDO (for the black plane) and J2 H WINDO (for the white plane), these signals being generated in the plane horizontal motion counters, paragraph 3.4.5.

The LOAD signals are non-coincidental and normally occur during H SYNC time. However, when a plane is traveling through H SYNC time (a condition detected by the type-74175 device in location D3) the LOAD signals are made to occur near the center of the screen. The exact location is determined at gate E1 pin 12. This change is made in order to avoid any "race" timing problems.

**3.4.8 PROCESSING OF ROM VIDEO INFORMATION AND GENERATION OF PLANE VIDEO SIGNALS (SHEET 2, ZONE C, D 5 AND 6):** Line, column, and rotation information are used to address the game's 4000 bits of ROM data storage; see para. 3.4.6. ROM data output (the signals ROM 0 thru ROM 7) is applied to the parallel inputs of two 8-bit parallel-to-serial converters. The pair of type-74165 devices in locations F4 and H4 form the black plane's converter, and the pair in locations J4 and K4 form the white plane's converter.

The  $\overline{LOAD\ 0}$  and  $\overline{LOAD\ 1}$  signals described in para. 3.4.7 are used to load the first and second bytes of ROM video information into the black plane's parallel-to-serial converter. *Byte is a generic term used to indicate a measurable group of consecutive binary digits.* Likewise,  $\overline{LOAD\ 2}$  and  $\overline{LOAD\ 3}$  are used to load this ROM video information into the white plane's parallel-to-serial converter. Note that the same ROM data are shared by both converters.

Each converter shifts out 16 bits or two bytes of ROM data when it is enabled by the signal applied at its "E" inputs (pin 15 on each type-74165 device). This enables signal is obtained at gate D4 pin 6 for the black plane by gating the J1 H WINDO (Jet 1 horizontal window) signal with the  $\overline{H\ BLANK}$  signal. It is also obtained at gate L1 pin 8 for the white plane by gating the J2 H WINDO signal with  $\overline{H\ BLANK}$ .

The serial information appearing at the converter outputs (at H4 pin 7 for the black plane and at K4 pin 7 for the white plane) is gated with the respective plane horizontal and vertical window signals. Two final plane video signals are produced:  $\overline{JET\ 1}$  at gate E2 pin 6 and  $\overline{JET\ 2}$  at gate E2 pin 8. With this arrangement, each plane's video signal is placed inside its video window. On the TV screen each plane video window takes up seven vertical lines, with each line having 16 bits of horizontal information.

**3.4.9 SHELL SPEED CODES, SHELL MOTION COUNTERS, AND SHELL VIDEO:** The circuitry that produces shell motion on the TV screen is very similar in design to the circuitry that produces plane motion. The black shell (fired by the black plane) and the white shell (fired by the white plane) each have their own horizontal and vertical motion counters. And these shell counters are clocked by the same signals that clock the respective plane counters. However, the shell motion counters can be preset to cause motion at a maximum rate of four unit moves per frame, while plane motion is limited to one unit move per frame. This feature of the design enables the shell to move across the TV screen at a rate exactly twice as fast as the plane rate. The shell motion counters are held in their reset mode until a shell is fired. A "timed enable" feature causes the shell to emerge from the center of its plane picture on the TV screen when a shell is fired.

Two 256-bit PROMs (programmable read-only memories) provide the shell video, one PROM for the black shell and one for the white shell. Each PROM has three shell pictures—one unexploded picture and two different explosion pictures. When a shell either reaches the end of its range, or else hits the opponent plane, the two explosion pictures alternately appear at a stationary location on the TV screen.

During travel across the TV screen a shell's motion is under control of a set of shell speed code signals.

(a) *Shell Speed Codes (sheet 1, zones B 5 and 6).* The black shell's speed codes, the signals S1C0 thru S1C7, are produced by the type-74116 8-bit latch in location L3. Those for the white shell, S2C0 thru S2C7, are produced by the type-74116 device in location J3. These type-74116 devices recover the shell speed and rotation data that are included in the information programmed in the game's

4000 bits of ROM storage capacity (see para. 3.4.6). When a shell is fired, the FIRE signal (FIRE 1 at L3 pins 3 and 15 for the black shell, and FIRE 2 at J3 pins 3 and 15 for the white shell) goes high. This causes the respective latch (L3 for the black shell and J3 for the white shell) to sample the ROM data (signals ROM 0 thru ROM 7) at a time designated by the rising edge of the signal applied at the latch's pins 2 and 14. For as long as the FIRE signal remains high, the speed code information held in the latch remains available on the latch output pins, becoming the legitimate shell speed code signals.

These speed code signals are used to preset the shell horizontal and vertical motion counters.

(b) *Shell Motion Counters (sheet 2, zones A, B, C, D 2 through 4).* The type-9316 devices in locations N2 and P2 form the horizontal motion counter for Shell 1 (the black plane's shell), and those in locations M2 and L2 form the vertical motion counter. Likewise, the type-9316 devices in locations H2 and F2 form the Shell 2 horizontal motion counter and those in J2 and K2 form its vertical motion counter. If no shell has been fired, all counters are held in their reset mode. A low state at flip-flop P1 pin 9 holds the Shell 1 counters at reset, and a low state at flip-flop P1 pin 5 holds the Shell 2 counters at reset.

Once a shell is fired, the reset is removed. This enables the respective pair of shell counters to begin counting at a time equivalent to their plane's location on the TV screen, as determined by the respective flip-flop "clock" input (P1 pin 3 for Shell 1 and P1 pin 11 for Shell 2). This "timed enable" feature causes a shell to be fired from the center of its plane.

Certain shell speed code signals (see para. (a) above) are used to preset the shell motion counters. For example, when the S2C0 through S2C3 signals preset Shell 2's horizontal motion counter H2, they cause one of the following: a short count (producing horizontal shell movement from right to left on the TV screen), or a long count (producing horizontal shell movement from left to right), or a normal count (which does not produce any horizontal movement).

The shell horizontal motion counters are limited to one "motion preset" per frame because both Shell 1's speed code signals S1C0 through S1C3 and Shell 2's speed code signals S2C0 through S2C3 are gated with the V RESET signal.

The presetting of Shell 1's vertical motion counter by shell speed code signals S1C4 through S1C7, and the presetting of Shell 2's vertical motion counter by shell speed code signals S2C4 thru S2C7, is carried out in the same manner as the presetting just described for the horizontal counters.

(c) *Shell Video (sheet 2, zones B, C, D 2 and 3).* The terminal count outputs from each pair of shell motion counters are ANDed with the respective FIRE signals to produce a shell "window" timing signal for each shell. Shell 1's window is produced at gate R2 pin 12, and Shell 2's window is produced at gate F3 pin 6. Each shell window signal enables a type-9312 8-bit multiplexer device (in location N1 for Shell 1 and in H1 for Shell 2). The multiplexers receive data from 256-bit PROM devices (in location M1 for Shell 1 and J1 for Shell 2) that have been programmed with the shell pictures. The multiplexers convert the PROM parallel output data into serial video information at N1 pin 14 for Shell 1 and at H1 pin 14 for Shell 2. After clocking, the final video signals SHELL 1 and SHELL 2 are produced at N1 pin 14 and H1 pin 14, respectively. On the TV screen each shell video window takes up 8 vertical lines, with each line having 8 bits of horizontal information.

No shell pictures appear on the TV screen until a shell is fired. The unexploded shell picture appears at the moment of firing and moves across the TV screen until it either reaches the end of its range, or hits the opponent plane. At that moment it is replaced by the explosion pictures. For Shell 1 this change-over time is determined at gate H3 pin 6 (sheet 1, zone B6) and for Shell 2 at gate N3 pin 8. Also the respective speed code latch (L3 for Shell 1 and J3 for Shell 2) is cleared at this change-over time, forcing all the shell's speed code signals (S1C0 thru S1C7 for Shell 1 or S2C0 thru S2C7 for Shell 2) to their low states. When a shell's speed code signals are all low, its motion counters are always preset to their normal count sequence, and so the shell's position remains stationary on the TV screen.

Also the respective EXPL signal (EXPL 1 at M1 pin 14 for the black shell and EXPL 2 at J1 pin 14 for the white shell) goes low whenever a shell either reaches the end of its range or else hits the opponent plane, causing its PROM to change over from the unexploded picture to the two explosion pictures. The signal 3F, generated by the frame counter (see paragraph 3.4.2) and applied at pin 13 of each PROM, causes the respective PROM to present the two explosion pictures alternately at the PROM outputs, at a rate of 3 frames per picture. The explosion pictures continue to appear, alternately, for as long as the FIRE signal remains high.

After FIRE goes low, the shells' motion counters are returned to their reset mode and the shell pictures disappear until a new fire sequence is initiated.

#### 3.4.10 GENERATION OF FIRE, EXPLOSION, HIT, AND BLOW-UP SIGNALS (SHEET 2, ZONES A 4 THROUGH 8):

(a) *Fire and Explosion Signals.* The type-9316 device in location E6 forms a digital timer for Shell 1 (the black

shell), and the type-9316 device in D7 forms an identical timer for Shell 2 (the white shell). The 3F signal from the frame counter described in paragraph 3.4.2 clocks each timer at E6 pin 2 and D7 pin 2. The operation of each timer is identical; the following description applies to the white plane's timer.

If the game is in the play mode, and provided that a previous white shell is not appearing on the TV screen, a pulse is produced at gate E5 pin 6 when a player depresses the trigger button on top of the white plane's joystick. This pulse passes through gate E4 and reaches pin 9 of digital timer D7. This pulse presets the timer to count 0, causing the  $\overline{\text{FIRE 2}}$  signal (at D7 pin 15) to go low and the FIRE 2 signal (at C7 pin 10) to go high. The  $\overline{\text{FIRE 2}}$  at low blocks additional fire commands, and the FIRE 2 signal at high enables the Shell 2 multiplexer (in location H1 in zone B2) to pass shell video from the PROM (in location J1). The white shell picture appears and begins to move across the TV screen.

The Shell 2 timer reaches a count of 8 approximately 0.8 second after the player has depressed the fire push button, causing the output at D7 pin 11 to go high and the  $\overline{\text{EXPL 2}}$  signal (at D8 pin 8) to go low. The  $\overline{\text{EXPL 2}}$  signal at low causes the Shell 2 speed code latch (the type-74116 device in location J3, sheet 1 zone B5) to reset the Shell 2 speed code signals S2C0 through S2C7. These speed code signals then hold the Shell 2 motion counters at normal counts, so that the shell remains in a stationary position on the TV screen. The  $\overline{\text{EXPL 2}}$  signal at low also addresses Shell 2's PROM (at J1 pin 14), and the PROM changes its output data from the unexploded picture to the explosion pictures. The explosion pictures appear on the TV screen while the Shell 2 timer is advancing from count 8 up to count 15.

When the Shell 2 timer reaches 15, its terminal count, the  $\overline{\text{FIRE 2}}$  signal (at D7 pin 15) goes high, causing the FIRE 2 signal (at C7 pin 10) to go low. The FIRE 2 signal at low keeps the Shell 2 pictures off the TV screen, causing the  $\overline{\text{EXPL 2}}$  signal to go high, and at D7 pin 10 prevents the timer from any further counting until a new fire sequence is initiated.

In a two-player game the FIRE 1 and EXPL 1 signals are produced in the same way as the FIRE 2 and EXPL 2 signals. In a one-player game the only difference is that the FIRE COM 1 signal (applied at gate E5 pin 13) is derived from the game's internal computer, rather than from the black plane's joystick signal (see paragraph 3.4.11).

(b) *Hit and Blow-up Signals.* A hit occurs whenever either a moving (unexploded) shell or stationary (exploding) shell coincides on the TV screen with the opponent plane, provided that the plane is not already in a hit

sequence. For Shell 1 (the black shell, the ANDing of the SHELL 1, JET 2 and  $\overline{\text{BLO UP 2}}$  signals produces a pulse at gate E1 pin 6 that resets flip-flop E7, causing the  $\overline{\text{HIT 1}}$  signal at E7 pin 5 to go low. Likewise, for Shell 2 (the white shell), the ANDing of the SHELL 2, JET 1 and  $\overline{\text{BLO UP 1}}$  signals produces a pulse at gate E1 pin 8 that resets flip-flop E7, causing the  $\overline{\text{HIT 2}}$  signal at E7 pin 9 to go low.

Shell motion immediately stops when a moving (unexploded) shell collides with the opponent plane, even though the shell's timer (in location E6 for Shell 1 and D7 for Shell 2) may have not yet reached the count of 8. The ORing of the  $\overline{\text{HIT}}$  signal (at E4 pin 12 for  $\overline{\text{HIT 1}}$  and at E4 pin 2 for  $\overline{\text{HIT 2}}$ ) in the preset gating causes the timer to be prematurely preset to a count of 8—see (a) above.

The HIT signals also connect to the score counters; see paragraph 3.4.12.

The  $\overline{\text{BLO UP}}$  signals are produced by the type-74279 R-S Latch device in location E8. For Shell 1 the falling edge of the  $\overline{\text{HIT 1}}$  signal sets a latch, causing the  $\overline{\text{BLO UP 2}}$  signal at E8 pin 7 to go low. The  $\overline{\text{BLO UP 2}}$  signal remains low until the falling edge of the FIRE 1 signal resets the latch. Likewise for Shell 2, the falling edge of  $\overline{\text{HIT 2}}$  sets a latch, causing  $\overline{\text{BLO UP 1}}$  (at E8 pin 9) to go low, where it remains until the falling edge of FIRE 2 resets the latch.

The  $\overline{\text{BLO UP}}$  signal is a 1-second pulse used to invert the plane video at a rate determined by the 3F signal from the frame counter. For the black plane the inversion signal is produced at gate K8 pin 8 (zone D5); for the white plane at gate K8 pin 6 (zone B5). The  $\overline{\text{BLO UP}}$  signal also forces the hit plane to rotate rapidly during its hit sequence. This rapid rotation is accomplished by ANDing the  $\overline{\text{BLO UP}}$  signal with the 1F signal from the frame counter, and then using the resultant signal to drive the plane's rotation counter. For Shell 1 the resultant signal at gate K8 pin 3 (sheet 3, zone C6) passes through gate H7 and on to the white plane's rotation counter in location J7. For Shell 2 the resultant signal at gate K8 pin 11 (sheet 3, zone D6) passes through gate H7 and on to the black plane's rotation counter in location H6.

**3.4.11 CIRCUITRY FOR 1-PLAYER GAME (SHEET 3, ZONES D6 AND 7):** During a two-player game each plane responds to commands from its joystick, but in a one-player game the black plane, Jet 1, receives its left turn, right turn, and fire commands from the game's internal computer circuitry. These internally-generated commands to the black plane will be functions of the black plane's position on the TV screen with respect to the white plane's position. This feature of the game's design enables the black plane to make "intelligent" turning and firing decisions while tracking the white plane's movement on the TV screen.

The type-74175 quad "D" memory device in location P5 stores the states of the J1V64, J1V128, J1H64, and J1H128 signals (generated by the black plane's vertical and horizontal motion counters, see paragraph 3.4.5) each time that the white plane's JET 2 video signal (applied at P5 pin 9) goes from low to high. The four outputs from the type-74175 device are applied to the A<sub>1</sub> thru A<sub>4</sub> address inputs of the 256-bit PROM in location R5, and the J1R4 signal (from the black plane's rotation counter, para. 3.4.4) is applied at the A<sub>0</sub> address input (at R5 pin 10).

The PROM's eight data outputs are applied to the type-74153 dual 4-to-1 multiplexer in location R6; the signals J1R2 and J1R3 (from the black plane's rotation counter) are applied to the multiplexer's two address inputs (at R6 pins 2 and 14). The PROM has been programmed so that the data appearing at the multiplexer's two outputs (R6 pins 7 and 9) will have the values shown in Table 3-1.

MULTIPLEXER OUTPUTS		VALUE
R6 pin 7	R6 pin 9	
1	0	Black plane to turn left
0	1	Black plane to turn right
1	1	Black plane to continue straight
0	0	Black plane to slow down and fire

Table 3-1 Single-Player Control Commands For Jet 1

The decoding logic consisting of inverters M7 and gates R7 converts the multiplexer's pair of output signals into the three single-player signals SP LEFT 1 (at R7 pin 13), SP FIRE COM 1 (at R7 pin 4) and SP RIGHT 1 (at R7 pin 10). These three signals, together with the corresponding signals from the black plane's joystick (LEFT 1\*, RIGHT 1\* and FIRE COM 1\*) are applied to the type-9322 multiplexer device in location J8. The state of the 1 PLAY signal (coming from the start circuit, paragraph 3.4.14), applied at J8 pin 1, determines whether the multiplexer selects the set of joystick signals or the set of signals from the internal computer just described.

Multiplexer J8's SLOW 1 output signal (at J8 pin 7) is used for plane speed control (see paragraph 3.4.3). LEFT 1 and RIGHT 1 (at J8 pins 9 and 12) are used in the black plane's rotation counter circuit (paragraph 3.4.4). The FIRE COM 1 signal (at J8 pin 4) is used in the circuit that generates the FIRE 1 signal—see paragraph 3.4.10 (a).

### 3.4.12 SCORE COUNTERS AND SCORE VIDEO:

(a) *Score Counters (sheet 2, zones C 5 and 6).* The

type-7493 device in location A6 is the black plane's score counter, and the type-7493 device in B5 is the white plane's score counter. The counters are driven by the respective HIT signals (HIT 1 at A6 pin 14 and HIT 2 at B5 pin 14); a counter is advanced by one count each time the plane's shell hits the opponent plane, up to a maximum count of 15. Both counters are reset to zero by a START signal pulse at the beginning of each new game. The counters are not reset during the attract mode, so that the final scores from the previous game remain showing during the subsequent attract mode.

(b) *Generation of Score Video (sheet 1, zones C 6 through 8).* The outputs from each score counter (see (a) above), J1S1 through J1S8 and J2S1 through J2S8, are applied to a type-9322 multiplexer device in location A5. The 128H signal (coming from the Sync Chain, see para. 3.4.2) is applied at A5 pin 1 and causes the multiplexer to pass the black plane's score count during the first half of each horizontal scan line of the TV screen, and to pass the white plane's score count during the second half. The multiplexer's outputs are applied to the A<sub>4</sub> through A<sub>7</sub> address inputs of the 1K-bit PROM in location A4; certain other signals from the sync chain are applied to the A<sub>0</sub> through A<sub>3</sub> address inputs.

The PROM has been programmed with appropriate numeral pictures to correspond with each count from the score counters. The PROM output data (at A4 pins 9 thru 12) are connected to the type-74153 4-to-1 multiplexer device in location A3. The three timing signals—8H and 16H (coming from the sync chain) and the score window signal coming from gate C6 pin 8—applied at A3 pins 14, 2 and 15, respectively, cause the multiplexer to produce serial score information at A3 pin 9. The signal produced at Gate C6 pin 8 provides the timing for the score windows on the TV screen. The GNE signal, applied at gate E4 pin 10 in the decoding logic that precedes gate C6, comes from the game timer circuit (see para. 3.4.15). This signal causes both scores on the TV screen to blink during the last one-fourth of the game time, indicating to players the game is nearing its end.

After clocking through flip-flop F1, the serial score information is separated by gate C3 as follows:

ANDing with the 32H timing signal from the sync chain produces the SCORE 1 signal (at C3 pin 11) that will determine which numerals appear in the black plane's score window in the upper left of the TV screen; and

ANDing with the 128H signal produces the SCORE 2 signal (at C3 pin 3) that will determine which numerals appear in the white plane's score window in the upper right.



The two  $\overline{\text{SCORE}}$  signals are connected to the video summing circuit (see paragraph 3.4.14).

**3.4.13 GAME SOUNDS:** No game sounds are produced during the attract mode. During the play mode two independently-driven speakers—one mounted at the left front of the cabinet (Speaker 1) and one at the right front (Speaker 2)—produce the following sounds. Speaker 1 produces the engine roar sounds for the black plane, Speaker 2 produces them for the white plane; and both speakers simultaneously produce a blast noise (whenever either plane fires a shell or a shell explodes by itself) and an explosion noise (whenever a shell hits a plane). A noise signal produced by a transistor noise generator modulates all the sound signals that are applied to each speaker's final output drive stage.

(a) *Noise Generator (sheet 3, zones B, C 1 and 2).* Transistor Q6 is an NPN specially-selected for noise characteristics. The noise developed at its emitter passes through two stages of amplification (provided by the dual LM324 amplifier in location B9); the NOISE analog signal is produced at B9 pin 7.

(b) *Engine Roar Circuit (sheet 3, zone D 3 and 4 and C 3 and 4).* The type-556 device in location F9 forms two independent VCOs (voltage-controlled oscillators), one VCO for each plane's engine sound circuit. The VCO with output at F9 pin 5 receives the  $\overline{\text{FAST 1}}$  and SLOW digital signals derived from the black plane's joystick commands (in a two-player game) or from the game's internal computer (in a one-player game). See paragraphs 3.4.3 and 3.4.11. After a D-to-A (digital-to-analog) conversion is made by an R-C network (R35, R36 and C18), the resulting analog signal applied at F9 pin 3 controls the VCO's output frequency. The  $\overline{\text{FAST 2}}$  and SLOW 2 derived from the white plane's joystick commands are processed in a similar fashion to control the other VCO's output frequency also.

The type-7474 dual flip-flops in locations B7 and B8 each form a 2-bit grey code counter that divides its respective VCO output frequency by 4. Various combinations of each counter's digital output signals are ANDed (in gate A7 for the black plane circuit, and in gate A8 for the white plane circuit); then the two sets of gate outputs are coupled through series capacitors to produce the JET SOUND 1 and JET SOUND 2 analog signals. Noise modulation is added by connecting in the NOISE analog signal—via R67 to the common capacitor point for JET SOUND 1, and via R68 for JET SOUND 2. Each JET SOUND analog signal is then applied to its respective speaker output drive stage (see paragraph (d) below).

(c) *Shot and Boom Synthesizer (sheet 3, zones B 1 and 2).* The SHOT & BOOM analog signal produced at the junction of resistor R77 and capacitor C45 is obtained by

mixing the following three separate analog signal contributions:

- (1) A noise modulation contribution made at the collector of transistor Q9. This transistor amplifies the NOISE analog signal applied at its base through resistor R58.
- (2) A "shot" contribution made by coupling amplifier B9's output at pin 1 through resistor R62. This amplifier stage is configured as a "triggered integrator." Whenever the EXPL 1 TRIG or EXPL 2 TRIG digital signals go high, transistor Q8 temporarily goes into conduction, decreasing the voltage level at the LM324 amplifier's inverting input (B9 pin 2). This input signal causes the analog signal produced at B9 pin 1 to initially swing high, and then to slowly integrate back down under the influence of the capacitance-coupled negative feedback loop provided by capacitor C29 (see upper waveform in Figure 3-6). The EXPL TRIG signals come from the shell digital timers; see paragraph 3.4.10 (a).
- (3) A "boom" contribution made by coupling amplifier output B9 pin 14 through resistor R76. This amplifier stage is also configured as a "triggered integrator" so that whenever the HIT 1 or HIT 2 digital signals go high, the analog signal produced at B9 pin 14 initially swings high and then slowly integrates back down; see lower waveform in Figure 3-6. However, this analog signal comes back down more slowly than the one at B9 pin 1, because capacitor C44 (0.22 microfarads) is twice as large as C29 (0.1 microfarads) and because R76 is only half as large as R62. This difference explains why the sound produced when a shell hits the opponent plane is twice as loud and twice as long as the sound produced when a shell is fired or when a shell explodes by itself. The HIT signals come from the HIT flip-flops; see paragraph 3.4.10 (b).

Potentiometer R62 provides a volume adjustment for SHOT & BOOM that is separate from the respective speaker volume adjustments, (see (d) below).

(d) *Speaker Output Drive Stages (sheet 4, zones B 3 through 7).* The LM380 amplifier in location D10 serves as the output drive stage for Speaker 1 and the LM380 in B10 serves as the output drive stage for Speaker 2. The signals that drive each stage are produced by mixing the respective JET SOUND and SHOT & BOOM signals. The signal produced at the junction of R53 and R54 is coupled through C26 and potentiometer R52 to drive amplifier D10. Likewise, the signal produced at the junction of R71 and R72 is coupled through C34 and potentiometer R70 to drive amplifier B10.

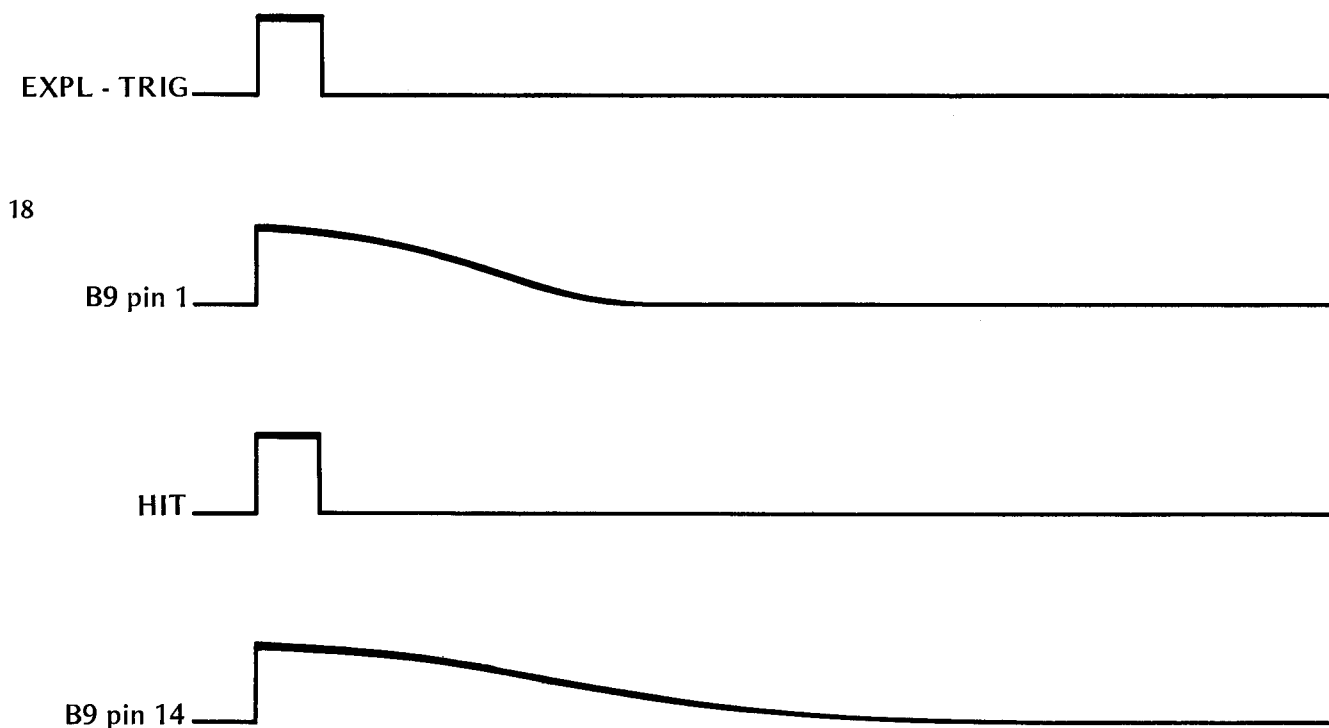

Figure 3-6 Audio Integrator Trigger and Output

Transistor Q1 prevents amplifier D10 from producing an output signal during the attract mode, and transistor Q2 does the same for amplifier B10. The potentiometers R52 and R70 provide individual volume adjustments for each speaker.

**3.4.14 VIDEO SUMMING (SHEET 1, ZONES C4 AND 5):** The junction of resistors R39 thru R42 forms the video summing point. The multi-level signal formed at this point is sent out, via edge connector pin 15, as the composite video signal to the TV monitor. The signal produced at R7 pin 1 and added through R40 is the synchronization information contribution. The signal produced at C5 pin 12 and added through R42 is the blanking contribution. The signal at D4 pin 3 and added through R39 is the contribution for the black plane, black shell and black score numerals. The signal at E4 pin 6 and added through R41 is the contribution for the white plane, white shell, and white score numerals.

**3.4.15 COIN AND CREDIT (SHEET 3, ZONES A, B, C 3 THROUGH 8):**

(a) *Coin Recognition Circuit.* Each coin mechanism has an SPDT switch that is activated momentarily whenever a coin passes through the coin mechanism and on into the coin box. The switch contacts are wired as shown on the harness schematic, drawing number 004279, with both C ("common") terminals tied to ground and each NC and NO contact connected through the harness to an individual pin on the PCB edge connector. Inverter latches "debounce" the switch closure signals from the coin switches and produce the CP1 and CP2 signals. The output from each latch is applied to a dual stage of flip-flops (formed by flip-flop P9 for signals from Coin Switch No. 1 and by flip-flop R9

for those from Coin Switch No. 2). One dual stage is clocked by the 128V and the other by the 256V signal, both coming from the sync chain (see paragraph 3.4.3).

Any inverter latch's output signal that is at least as wide as two cycles of the clocking signal (approximately 30 milliseconds) will cause the appropriate dual-stage flip-flop to produce an output pulse (at P9 pin 5 for Coin Switch No. 1 signals, and at R9 pin 5 for Coin Switch No. 2 signals). This pulse will pass through gate C5 to produce a COIN signal pulse (at C5 pin 6) and through inverter C7 to produce a COIN signal pulse (at C7 pin 2). The COIN signal will set the "Q" latch, formed by discrete transistors Q3 and Q5, through Diode D6, causing the Q signal (at F8 pin 6) to go high and remain high. See paragraph (d) below for a description of the "Q" latch.

The "common" contact of Switch S1, a two-position slide switch mounted on the PCB, connects to the "Set" input (pin 4) of flip-flop C8. Switch S1 provides the game's 1 player/coin-2 players/coin option feature.

The owner/operator manually places this switch in the "50¢" position to structure the game for 1 player/coin, and in the "25¢" position for 2 players/coin. When S1 is in the "25¢" position, the flip-flop's "Set" input (pin 4) is connected through the switch contacts to ground. This grounding forces the flip-flop output (at pin 5), the 2 CREDIT signal, to steady high regardless of the states of signals applied at the flip-flop's clocking and "D" inputs (C8 pins 3 and 12). When S1 is in the "50¢" position, a momentary low can be applied to the flip-flop's "Set" input only by the gate D4 output at pin 11; this low only is produced if two players should by chance deposit two coins simultaneously, one in each coin mechanism.

Disregarding this case of simultaneous deposit of two coins, when S1 is in the "50¢" position the flip-flop's 2 CREDIT signal will go high only if the Q signal (applied at the "D" input, pin 2) is high at the time that the COIN signal goes from low to high. The "Q" latch's turn-on delay insures that the Q signal will not have reached high by the time the COIN pulse produced by the first coin deposit has clocked the flip-flop (at C8 pin 3). Therefore a second COIN pulse (initiated by a player depositing a second coin) will be needed in order to cause the 2 CREDIT signal to go high. In the "50¢" mode, the 1 CREDIT signal (at D8 pin 6) will be high only when 2 CREDIT is low. In the "25¢" mode, 1 CREDIT will be high continually, regardless of the state of 2 CREDIT.

The 1 CREDIT and 2 CREDIT signals are applied to the inputs of a type-74153 multiplexer in location L9. The multiplexer has two outputs that each connect through a resistor to the gate terminal of an SCR. SCR T1 drives the lamps that provide backlighting for the "one player start" push-button switch on the front panel, and SCR T2 likewise provides backlighting for the "two player start" switch.

The ATTRACT signal applied at pin 2 of multiplexer L9 insures that neither push-button switch will be lighted during the attract mode. The 1 PLAY signal, applied at L9 pin 14, is high for a one-player game and low for a two-player game. After a coin is deposited, the multiplexer responds to the states of the 1 CREDIT, 2 CREDIT and 1 PLAY signals by producing signals at outputs L9 pins 7 and 9 that cause the SCRs to backlight the appropriate push-button switch or switches, in conformance with the game structuring at Switch S1.

Any pulse to high by the COIN signal will bring power transistor Q11 into conduction and its collector current pulse will increment the coin counter by one count. The coin counter is mounted on the coin assembly access door.

(b) *Generation of START signal.* As shown on the harness schematic, drawing number 004279, the normally closed contact of each front panel push-button switch is wired to ground, and each common contact is connected to the PCB via the harness. On the PCB each switch's signal connects to a junction point formed by a resistor, a capacitor and an input to gate D9. Because the Q signal is low until a coin has been deposited, the application of this signal at inputs to gate D9 insures that the game will not respond to a player depressing either push button during the attract mode.

Once a coin has been deposited, Q goes high and START circuitry reacts in one of two ways, depending on the setting of switch S1. If S1 is in the "50¢" position, the first coin will enable the 1-player start switch (1 CREDIT is

high), and disable the 2-player start switch (2 CREDIT is low). If a second coin is deposited, it will then disable the 1-player start switch (1 CREDIT is low) and enable the 2-player start switch (2 CREDIT is high).

If S1 is in the "25¢" position, the first coin entered will enable both the 1-player and 2-player start switches, since both 1 CREDIT and 2 CREDIT are high. The appropriate backlighting of the switches indicates whether the 1-player and/or 2-player start switch is enabled, once the coin(s) has been entered.

If a player now depresses the lighted 1-player start switch, gate D9 pin 1 will go high, causing the output at gate D9 pin 6 to go low. The gate D8 pin 3 output will go high, and a START pulse approximately 63.5 microseconds wide will be produced at D3 pin 15.

Likewise, a START pulse will also be produced if a player depresses the lighted 2-player start switch. The 1 PLAY signal will go low as well, because the low signal produced at D9 pin 8 resets latch E8 at pin 14.

The START signal at high causes the planes to reset to their initialized flight paths (by resetting both rotation counters and the plane horizontal motion counters), causes both scores to change to zero (by resetting both score counters), and enables the Game Timer. See paragraph (c) below.

(c) *Game Timer.* The type-555 device in location K9 and the type-7490 divide-by-10 decade counter in location D5 form the game timer, and the type-74279 device in location E8 forms the end game latch. The type-555 device is configured as a 10-second oscillator, but the ATTRACT signal (applied at K9 pin 4) prevents it from operating during the attract mode. The START signal, applied at D5 pins 2 and 3, resets the type-7490 counter to count 0 when a player depresses a lighted push button to initiate a play sequence. The count 0 brings the ATTRACT signal (produced at D5 pin 11) low. This signal at low enables the type-555 device to begin to oscillate, and also enables various other game functions such as the game sounds and player control of planes and shells.

Each oscillation of the type-555 device (at K9 pin 3) advances the type-7490 counter by one count. When the total count reaches 6, the GNE signal goes low. This signal connects to the logic that generates the score windows and causes the score numerals on the TV screen to blink during the last one-fourth of the game time. When the count reaches 8, the ATTRACT signal is brought high, disabling the type-555 device and also disabling the player controls. The count of 8 also produces a low at gate D4 pin 8 that sets the end game latch, bringing the END GAME signal low and resetting the "Q" latch (see paragraph (d) below).

The potentiometer R20 provides the game time option. When the owner/operator manually adjusts this potentiometer, the type-555 device's oscillator frequency is either increased or decreased, with the result that game time is either shortened or lengthened.

(d) "Q" Latch. Transistors Q3 and Q5 form a discrete component latch. Note that they are complementary: Q3 is a PNP and Q5 is an NPN. The two stable states of the latch are: *neither* transistor conducting (game time has elapsed), and *both* transistors conducting (coins just deposited or else game timer in operation). The latch is set via Diode D6 when the  $\overline{\text{COIN}}$  signal goes low; normally it is reset when the  $\overline{\text{END GAME}}$  signal goes low (see paragraph (c) above). However, the latch will also be reset should transistor Q4 at any time go into conduction and force Q5 out of conduction. The antenna wire is connected to the base of Q4 and a signal produced on this wire by static discharge current flow will cause the latch to reset.

The Q signal at F8 pin 6 is high when the "Q" latch is set, and low when the latch is reset. The  $\overline{\text{Q}}$  signal (at F8 pin 8) at low resets the type-7490 device in the game timer to a count of 9, bringing D4 pin 8 high and removing the "set" condition on the end game latch. This removal of the set condition then allows any new coin-switch-produced signals as a low on  $\overline{\text{CP1}}$  or  $\overline{\text{CP2}}$  (E8 pin 2 and 3) to reset the end game latch. When the  $\overline{\text{END GAME}}$  signal goes back to high, the reset condition (at diode D1) is removed from the "Q" latch. A new pulse to low on the  $\overline{\text{COIN}}$  signal can then set the "Q" latch via diode D6.

An additional feature of the "Q" latch's design is that it functions as a detector for low line voltage, line voltage "spikes," and the "power on" condition; the latch will automatically reset itself under any of these conditions.

# IV. Installation Instructions

## 4.1 UNPACKING INSTRUCTIONS

**4.1.1 EXAMINATION FOR SHIPPING DAMAGE:** Before shipment from the factory, components and sub-assemblies of each game are carefully checked for proper operation. However, during shipment some adjustments may have changed or parts may have been damaged. Upon initial removal of the game from the shipping container, first examine the exterior of the cabinet. On the front panel push each joystick lever all the way back and forward, and all the way to the left and right; lever movement should be free and smooth. Then open the rear panel access door and also examine the interior of the cabinet.

Any shipping damage such as a dented, cracked or broken cabinet, sub-assemblies broken loose, etc., should be reported immediately to the shipper and to Atari, Inc.

**4.1.2 MECHANICAL INSPECTION:** After determining that the game has been received in good condition, carefully inspect the interior parts and verify the following:

- (a) All slip-on and plug-in connectors are firmly seated (particularly the PCB edge connector)
- (b) The fuses are all seated in their holders
- (c) No loose foreign objects are present (especially metal objects which could cause electrical short circuits)
- (d) No harness wires have become disconnected or pulled loose.

Be sure all major assemblies have been checked: the TV monitor, the printed circuit board, the electronics tray, the coin mechanisms, both speakers, the underside of the player control panel where the joysticks and push-button switches are mounted, and the interlock switch activated by the rear panel access door.

Do not go on to the remaining paragraphs in this section until the above mechanical inspection has been thoroughly performed.

## 4.2 ENERGIZING THE GAME

**4.2.1 APPLICATION OF AC POWER:** Close the rear panel access door, making sure that it is completely shut at the bottom, and remove the key from the lock. Plug the power cord into an AC outlet providing the AC power listed in the Specifications (Section II of this manual). The wall outlet must accept a three-prong plug and the receptacle must be connected to a good earth ground. After the power cord has been plugged in, the proper response from the game is the TV screen should light up and images should begin to appear.

If there is no response at all from the game, unplug the

power cord and check the AC wall outlet. A simple, safe way to check for presence of AC power at the wall outlet is to plug in an appliance known to be working properly, such as a table lamp, radio, or an electric clock. If the wall outlet passes the check, then presume that the trouble is with the game and refer to Section VI of this manual.

*CAUTION: No troubleshooting steps should be attempted inside the cabinet by anyone not familiar with safety measures and repair procedures on electrical equipment.*

Do not go on to the remaining paragraphs in this section until the proper response described above has been observed.

**4.2.2 CHECK ON OPERATION OF INTERLOCK SWITCHES:** The interlock switches are safety switches connected to the AC power circuit. They are mounted inside the cabinet, one in the upper portion of the cabinet, near the bottom edge of the rear panel access door, and the other in a similar position in the lower, main portion of the cabinet. At the factory these switches are mechanically adjusted so that the upper switch will automatically transfer to its "off" position (switch contacts open) whenever the upper rear panel access door is opened, and likewise the lower switch will automatically transfer to "off" whenever the lower rear panel access door is opened. While an access door is closed, the corresponding interlock switch is adjusted to be in the "on" position (switch contacts closed). With this arrangement, only while both access doors are closed is the AC power allowed to reach the game's power supply, meaning that the game can operate.

After application of AC power per paragraph 4.2.1 above, correct operation of the interlock switches can be checked in two steps, as follows:

- Step 1) Unlock and open the upper rear panel access door. The correct response is that by the time the edge of the door has moved about 2 to 3 inches away from the cabinet, the TV screen should go dark, verifying that the interlock switch has automatically transferred to "off." While opening the access door, do not insert fingers inside the cabinet, and do not allow foreign objects to fall inside. If images are still present on the TV screen even after the door has been opened, immediately close and lock the door, and unplug the power cord from the wall outlet. Then refer to Section VI of this manual to replace and/or adjust the interlock switch. If the correct response was obtained, then close and lock the access door.

Step 2) Unlock and open the lower rear panel access door. The correct response is the same as described in Step 1 above. If the correct response is obtained, then close and lock this access door also.

Do not go on to the remaining paragraphs in this section until the operation of both interlock switches has been checked and found to be correct.

### 4.3 GAME STRUCTURING

Before putting the game into operation at the game site, the game structuring should be defined by the owner/operator. The term *game structuring* refers to the game rules and the length of the game time per play sequence. Para. 3.3.4 of Section III in this manual lists the owner/operator options featured in this game and describes how they affect the game structuring.

In the Jet Fighter game both options are simple manual adjustments: setting the position of a slide switch, and moving a stud on a potentiometer body. Both adjustments are done on the printed circuit board inside the game cabinet.

Before performing either adjustment, the game should be de-energized or not operating. Further, it is also recommended that the power cord be unplugged beforehand.

Unlock and open the rear panel access door; doing this should cause the interlock switch to de-energize the game, as described in para. 4.2.2. If the switch fails to de-energize the game, immediately close and lock the door, unplug the power cord, and refer to Section VI of this manual to adjust and/or replace the switch.

While being careful to avoid touching any parts of the body against the TV chassis components or other wiring connections inside the cabinet, find the printed circuit board and examine its surface.

#### 4.3.1 NUMBER OF PLAYERS PER COIN OPTION:

Find the two-position slide switch mounted near the edge of the PCB. The switch's approximate location is shown in Figure 4-1, and its exact location is shown adjacent to R11 on drawing number A004245 in Section VII of this manual. Note the numbers "25" and "50" engraved on the PCB alongside the switch body.

To structure the game for 1 player/coin, slide the stud on top of the switch all the way toward the number "50" engraved on the PCB. To structure the game for 2 players/coin, slide the stud all the way toward the number "25."

After performing this adjustment, close and lock the rear panel access door and energize the game.

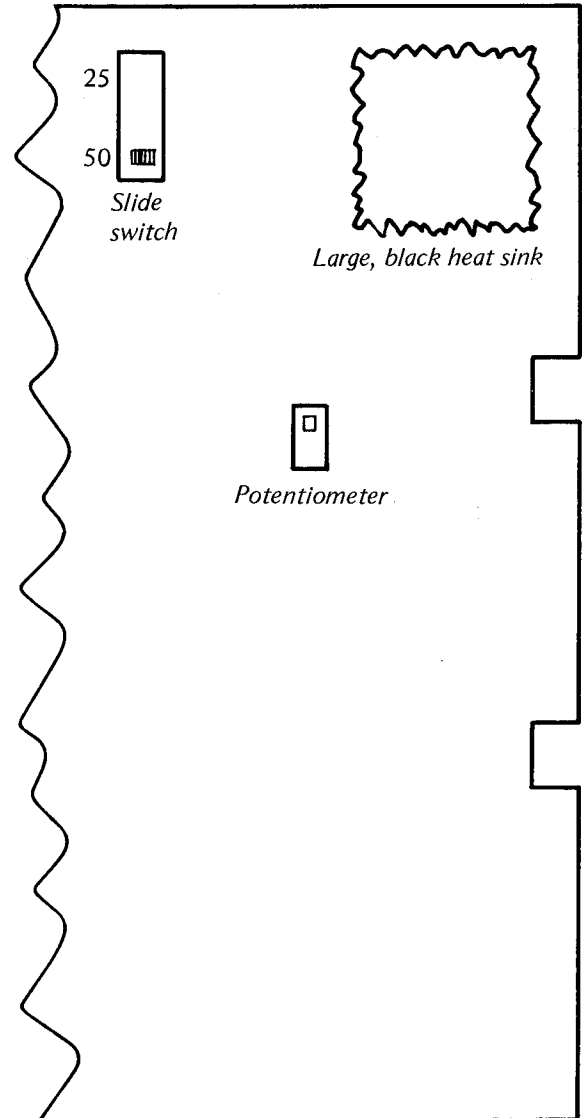

Figure 4-1 Location of Players-per-Coin Switch and Game Time Potentiometer

**4.3.2 LENGTH OF GAME TIME OPTION:** Find the potentiometer (Trimpot) mounted near the center of the board, at the edge-connector end. This potentiometer's approximate location is shown in Figure 4-1, and its exact location is shown as R20 on drawing number A004245 in Section VII of this manual. Note the words "GAME TIME" engraved on the PCB alongside the potentiometer body. To shorten or length the game time, move the stud on top of the potentiometer in either direction as shown in Figure 4-2.

After performing this adjustment, close and lock the rear panel access door and energize the game.

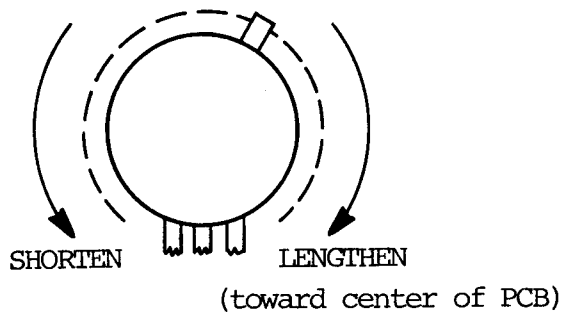

Figure 4-2 Game Time Adjustment

#### 4.4 FUNCTIONAL CHECK OF GAME OPERATION

The following procedure provides a simple check that can be quickly performed at the game site and that does not require external test equipment. If at any point during this procedure the game's response is observed to be other than the response called for herein, assume the game is not operating correctly and refer to Section VI of this manual. If all the responses are as described here, then all major parts of the game can be assumed to be functioning correctly.

After performing the adjustments described in para. 4.3, Game Structuring, and in para. 4.2, Energizing the Game, the game should be operating in the attract mode, as per para. 3.3.2. The speakers should not be producing any sound. Observe the TV screen.

Just after the game is energized, near the top of the TV screen random numerals may be appearing in the two score displays; numerals in the left-hand display should be black and those in the right-hand display should be white. The black and white planes should each be flying in random directions across the screen, each plane retracing its own straight-line path over and over again. Neither plane should be firing shells.

While watching the TV screen, exercise the joystick lever on the left side of the player control panel. Movement of the lever to any position should not produce a response from either plane. Next exercise the other joystick lever and confirm again that there is no response from either plane.

Look at the two push button switches on the player control panel; neither switch should be lighted. While watching the TV screen, depress each button, one at a time. Doing this should not produce any response from the game.

Depress the coin rejector button on each of the two coin acceptors; make sure that each linkage is operating smoothly. Deposit a coin; no genuine coin should be

rejected. Upon acceptance of a coin the game should respond by changing over to the play mode. If the game is structured for 2 players/coin, both push buttons should light up. If the game is structured for 1 player/coin, only the right-hand button (engraved ONE PLAYER START) should light. If structuring is for 1 player/coin, deposit a second coin. Doing this should cause the right-hand button to extinguish and the left-hand button (engraved TWO PLAYER START) to light.

Again observe the TV screen. Although push buttons have lighted, motion of the planes across the screen should be undisturbed and the same scores should continue to be displayed. Again exercise both joysticks and confirm that there is no response from the game. Also, up to this point the speakers should not be producing any sound.

Depress the left-hand push button (TWO PLAYER START). The game should respond as follows:

- (a) All switch backlighting is extinguished.
- (b) Both speakers begin to produce identical engine roar sounds.
- (c) The motions of the planes change over to parallel straight-line paths moving from the bottom of the screen toward the score displays at the top, with the black plane on the left and the white plane on the right.

Next check each plane's response to commands from its joystick by performing the following steps twice, once for each joystick. If game time ends before completing all steps, deposit additional money and initiate a new play mode.

- (a) Pull the joystick lever all the way straight back. The plane's speed should noticeably slow down, and the pitch of the engine roar sound produced by that plane's speaker should decrease. Return the joystick to the central position.
- (b) Next push the joystick all the way straight forward. The plane's speed should noticeably speed up and the pitch of that plane's engine roar sound should increase. Return the joystick to the central position.
- (c) Depress the push button "trigger" on top of the joystick lever, and then release it. The plane should fire a shell and both speakers should produce the blast noise. The shell should travel in a straight line and at a speed twice as fast as that of the plane. After having traveled over a distance equal to about three-fourths of the screen width, the shell should explode. Both speakers should again produce the blast noise. Fire another shell, release the trigger, and then immediately try to fire more shells. The game should not respond

until after the shell already on the screen has exploded.

- (d) Watch the TV screen, and when the plane is near the center of the screen, move the joystick all the way directly to the left. The plane should begin a smooth, circular turn to the left and should continue to turn counterclockwise. Return the lever to the central position; the plane should cease turning and should fly off in a straight line.
- (e) Watch the TV screen, and when the plane is near the center, move the joystick all the way to the right. The plane should begin a smooth, circular turn again, this time to the right, and should continue to turn clockwise. Return the lever to the central position. The plane should again fly off in a straight line at the moment the joystick was brought back to the central position.

After correct joystick operation has been confirmed for both planes, observe the score display while letting the game time run out. The numerals in the display should begin to blink after seven-eighths of the game time has elapsed, and should continue to blink throughout the final one-eighth of the game time. When game time ends, the speakers should cease to produce sound, the planes should continue to fly in straight lines, and neither start push button should be lighted. Confirm that movement of the joysticks produces no response from the game.

Deposit another coin and depress the right-hand push button (ONE PLAYER START). Confirm that movement of the left-hand joystick, the black plane's joystick, produces no response from the game. Allow the black plane, which is now under control of the game's internal computer, to fire a shell into the white plane. When this happens both speakers should produce the explosion sound; this sound will be twice as loud and twice as long as the blast sound. The black plane's score (in black numerals at the top left of the screen), should change from "0" to "1." And the white plane should go into a hit sequence, as follows:

- (a) The plane's video will immediately invert (white plane will change to black video surrounded by a white video rectangle), the plane will stop, and it will begin to rotate very rapidly.
- (b) After one second elapses, the plane video should return to normal and the plane should fly away in a straight line along the orientation held at the moment the rotation ceased.

Next exercise the white plane's joystick so that the white plane fires a shell into the black plane. Doing this should cause both speakers to produce the explosion sound, the white plane's score (in white numerals at the top right of the screen) should change from "0" to "1," and the black plane should go into its hit sequence.

This completes the functional check of the usual game sequence. For adjustment of game sound volume refer to para. 5.3 and 5.4 in Section V of this manual.



# V. Maintenance and Adjustments

## 5.1 ROUTINE MAINTENANCE

Due to its solid-state electronic circuitry, this Atari game should require very little maintenance and only occasional adjustment.

**5.1.1 CLEANING:** Game cabinets and glass may be cleaned with any non-abrasive household cleaner. If desired, special coin machine cleaners which leave no residue can be obtained from distributors.

**5.1.2 LUBRICATION:** About once every three months lightly spray the rejector linkage portion of the coin acceptor inside the coin mechanism. Use WD-40® or similar lubricant, and *avoid* spraying the entire coin acceptor. Potentiometer shafts must *never* be lubricated in any way.

## 5.2 ADJUSTMENTS ON TV MONITOR

The TV monitor need be adjusted *only* when the picture is distorted, or if contrast or brightness seem out of adjustment.

*NOTE: The TV monitor is accessible only from inside the game cabinet, and these adjustments have to be made while the game is energized. Therefore only persons familiar with*

*safety measures and repair procedures on electrical equipment should perform these adjustments.*

The TV monitor's adjustments function like those of a conventional commercial TV set, except that the volume adjustment has no effect. The Jet Fighter game produces its sound in a speaker separate from the TV monitor. Figure 5-1 shows the location of these adjustments on the rear of the TV monitor chassis. The following are general guidelines to follow while making these adjustments:

- BRITE (Brightness)**—This should be adjusted before the contrast. Adjust the brightness so that the white lines covering the screen just barely disappear, when the brightness is turned up.
- CONT (Contrast)**—Adjust so that the images are as bright as possible against the dark background without being blurred.
- HORIZ HOLD (Horizontal Hold)**—Adjust if the picture is slightly off-center horizontally, if the images appear warped, or if the picture is broken up into a series of diagonal lines. Adjust for a stable, centered picture.
- VERT HOLD (Vertical Hold)**—This needs adjustment only if the picture appears to be rolling up or down the screen. Adjust for a stable, centered picture.

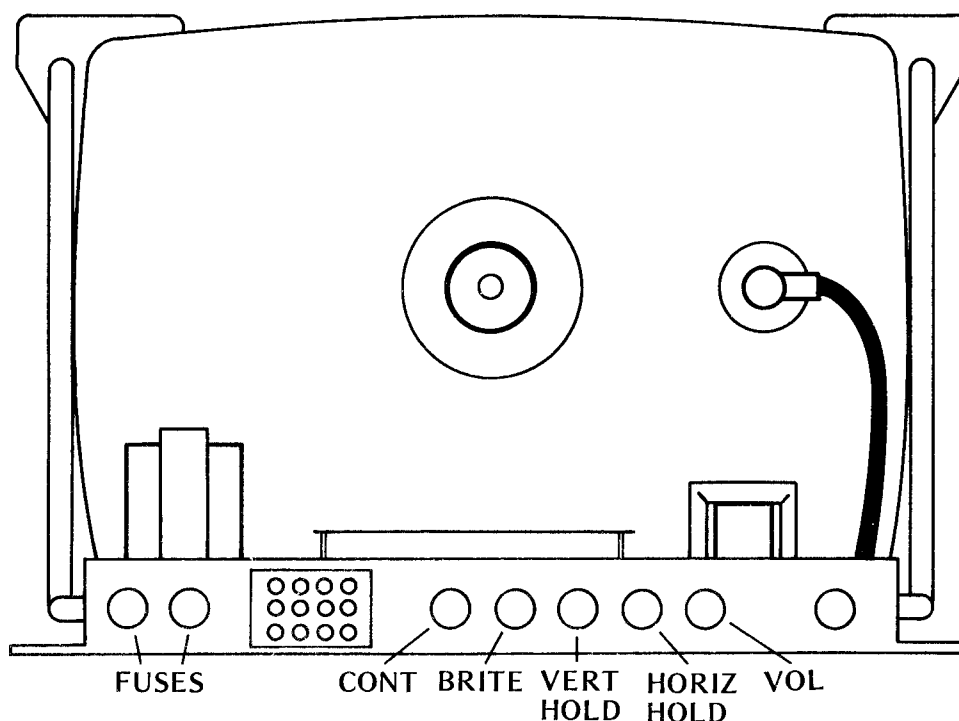

Figure 5-1 Location of Adjustments on TV Chassis

### 5.3 ADJUSTMENT OF BOTH SPEAKER VOLUMES

Each speaker's electronic drive circuit is provided with a potentiometer that controls the volume of sounds produced by the speaker. These potentiometers are independent of one another and each can be easily adjusted manually. Para. 3.4.13 in Section III of this manual describes operation of the speaker drive circuit.

Unlock and open the rear panel access door; doing this should cause the interlock switch to de-energize the game, as described in para. 4.2.2. If the switch fails to de-energize the game, immediately close and lock the door, unplug the power cord, and refer to Section VI of this manual to adjust and/or replace the switch.

While being careful to avoid touching any parts of the body against the TV chassis components or other wiring connections inside the cabinet, find the printed circuit board and examine its surface.

Both of these potentiometers are found near the edge connector end of the PCB. Their approximate locations are shown in Figure 5-2, and their exact locations are shown as R52 and R70 on drawing number A004245 in Section VII of this manual. Note the designations "VOL 1" (for the left speaker) and "VOL 2" (for the right speaker) engraved on the PCB alongside the potentiometer bodies.

To cause a speaker to produce louder or quieter sounds, move the stud on top of the potentiometer in either direction as shown in Figure 5-3. After performing these adjustments, either go on to para. 5.4 or else close and lock the rear panel access door and energize the game.

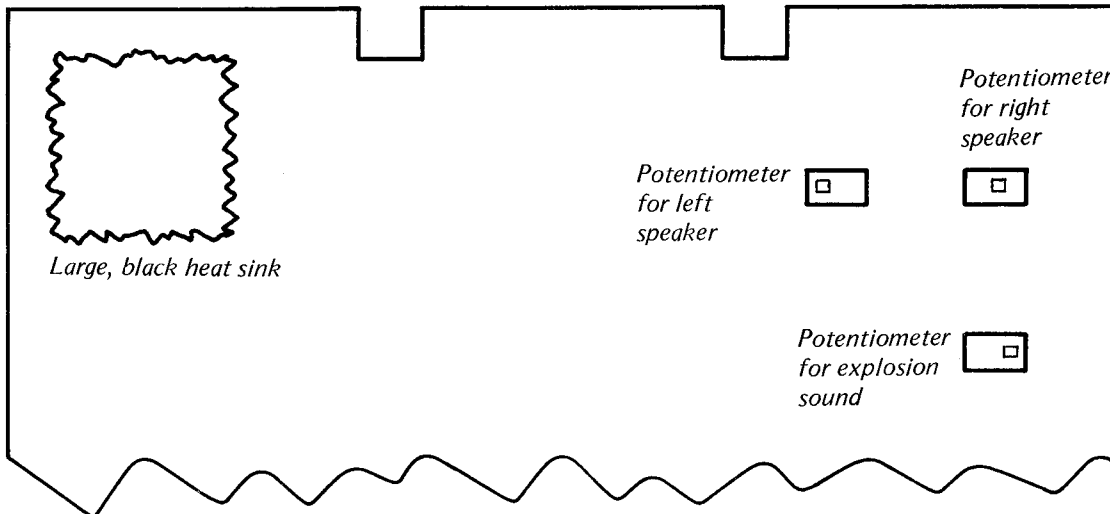

Figure 5-2 Location of Potentiometers Controlling Speaker & Explosion Volume

### 5.4 ADJUSTMENT OF EXPLOSION SOUND

After the speaker volumes have been adjusted as described in para. 5.3, the relative volume of the explosion sound with respect to the other game sounds can be separately adjusted. A potentiometer in the sound synthesizer circuit controls the relative volume of the explosion sound produced whenever a shell hits a plane. (Para. 3.4.13 in Section III describes the operation of the sound synthesizer circuit.) This potentiometer can also be easily adjusted manually.

The potentiometer is located near the "VOL 1" and "VOL 2" potentiometers. Its approximate location is shown in Figure 5-2, and its exact location is shown as R69 on drawing number A004245. Note the words "EXPL" engraved on the PCB alongside the potentiometer body.

To make the explosion sound louder or quieter, move the stud on top of the potentiometer in either direction as shown in Figure 5-4. After performing this adjustment, close and lock the rear panel access door and energize the game.

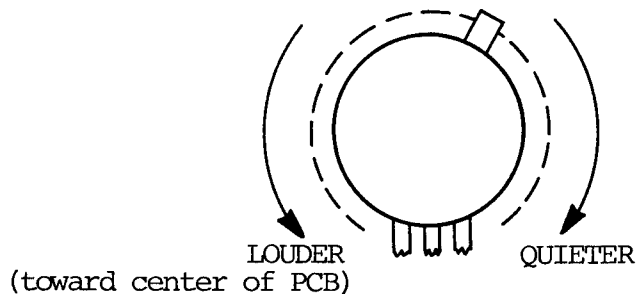

Figure 5-3 Speaker Volume Adjustment

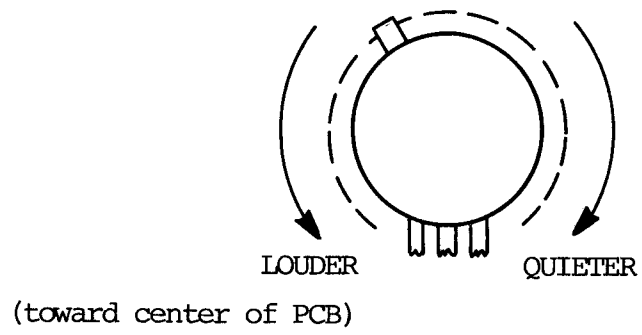

Figure 5-4 Adjustment of Explosion Sound

# IV. Troubleshooting and Repairs

## 6.1 GENERAL PROCEDURE

*This section describes troubleshooting procedures in detail sufficient for a person with moderate technical ability to understand. However, for those interested in gaining more information on video game technology, especially the electronics, we recommend reading the Video Game Operator's Handbook, manual no. TM-043. This book is available from Atari, Inc., attn. Customer Service Dept., 2175 Martin Avenue, Santa Clara, CA 95050, for \$5.00 each, or from your distributor.*

**6.1.1 IDENTIFYING THE TROUBLE AREA:** The first troubleshooting step should be to note all observable trouble symptoms. Examples of symptoms are: depositing a coin produces no game response, no sound coming out of the speaker at any time, no picture on the TV screen. At the same time also note the game features that still work. A systematic way of checking game operation is to perform the functional check given in Section IV of this manual. Carefully train your eye to pick up all clues; by doing this an experienced troubleshooter can often spot the cause of a trouble even before he opens the cabinet.

Keeping these observations in mind, next apply the understanding of game operation gained from the Theory of Operation (Section III) and from the schematic drawings (Section VII). Narrow down the suspected cause of the trouble to a specific area or areas of the game.

Be careful not to overlook possible trouble areas that may seem too obvious: a power cord plug that has worked loose from the wall outlet and no longer is fully seated in the receptacle, or a rear panel access door that is not fully closed (thus causing the interrupt switch to block the AC power path to the game).

**6.1.2 LOCATING THE TROUBLE CAUSE:** Once a problem has been narrowed down to one or more areas, the next step is to perform various tests and measurements to isolate a specific cause of the trouble. Remember that sometimes a very complicated problem, such as erratic game operation, can be traced to a simple cause—the printed circuit board not being fully seated in its edge connector. Start with the most suspect area and trace backwards from the point where the trouble is first observable, using a process of elimination to eventually locate the faulty component, connection, etc. For example, if no sound is audible during game play, first check for a signal at the speaker leads. If no signal is present there, go back through the wiring harness connections to the printed circuit board. If there is still no signal, then systematically check back through the various components of the sound generation circuit.

Substitution of parts is a legitimate and easy way to isolate the cause. For instance, if the PCB is the suspected trouble area, remove it and substitute a known-to-be-good PCB. Then check for correct game operation. Similarly, to check the TV monitor, connect the game to a known-to-be-good monitor. The harness can often be checked by substitution also. Substitute both a known-to-be-good PCB and TV monitor. If the trouble still persists, the harness must be at fault.

While locating the trouble cause, use the technical descriptions in Section III as guides for correct circuit-level operation, and the schematic drawings of Section VII as roadmaps for tracing signal flow paths.

The test equipment for use in troubleshooting is discussed in para. 6.2.

**6.1.3 CORRECTING THE TROUBLE CAUSE:** In practice, the steps required to correct troubles can range from simple adjustments (fully seating the PCB in its edge connector, changing the setting on a potentiometer, adjusting the picture controls on the TV monitor) to repair of loose connections and replacement of defective parts. Extreme care should be exercised when removing integrated circuit devices and discrete components. Use a 40-watt soldering iron with a small tip designed especially for IC work. To remove an IC device, follow this procedure:

Remove all solder from both sides of the PCB, first melting it with the hot iron and then sucking up the molten solder with a Soldapull<sup>®</sup> solder sucker. After all the solder is gone, remove the IC device by gently prying up. Afterwards clean the area thoroughly, using an approved PCB cleaning solution to remove any traces of flux and dirt. Alcohol will do in a pinch, if necessary.

Insert the new IC device using an IC insertion tool, making sure that the reference notch is oriented correctly and that the device's leads are not bent during insertion into the board. Afterwards, be sure to solder each lead on *both* sides of the PCB, using as little solder as possible. After soldering, clean the area thoroughly to remove the flux.

Observe the same removal and insertion procedures when replacing discrete components. Trim the leads as close as possible and be sure to orient diodes and capacitors correctly.

**6.1.4 VERIFYING CORRECT GAME OPERATION:** After locating and correcting the cause of a trouble, re-energize the game and perform a final check on correct game operation. Doing this will verify that your troubleshooting was correct. If the game operation is still not correct, go back and double-check your work. Make sure

that any replaced components were installed correctly. If this was done properly, then start the troubleshooting steps over again. Keep in mind that there may be more than one trouble at a time, and that correcting one trouble can sometimes bring previously undetectable troubles to light.

This verification is especially important when the original trouble had been intermittent, that is, was not happening all the time.

## 6.2 TEST EQUIPMENT

Electronic troubleshooting of a video game essentially consists of checking for the presence of various signals and of examining their condition. A signal can be thought of as acting like a "messenger" that carries instructions from one unit or circuit to another. Many different types of signals are produced in a video game, and for this reason several unusual and perhaps unfamiliar types of test instruments are used during troubleshooting. Each instrument has its own set of advantages and disadvantages for examining a given type of signal, and both the depth of the intended troubleshooting capability and budget will determine which instruments will be needed. Some instruments are basic and essential, no matter what size of service facility, while other optional instruments are desirable because they make troubleshooting easier and quicker.

### 6.2.1 BASIC TEST EQUIPMENT:

(a) *The Video Probe.* This is a simple but invaluable instrument having two leads—a test-clip lead and a test-probe lead. During troubleshooting of video signals the test-clip lead is left connected to the game at the video summing point. On the Jet Fighter game this point is the junction of resistors R39, R40, R41 and R42 on the PCB.

When the test-probe lead is then connected to any video developmental signal, that signal will be coupled to the video signal going to the TV monitor and a video probe picture will appear on the TV screen. The shape and other characteristics of this picture will give information about the signal being probed. The video probe is suited for troubleshooting synchronization and image signals, but will not be useful for extremely fast signals (such as the clock) or for very slow analog or digital signals.

A video probe can be constructed in a few minutes from these common electrical components: a length of 20 AWG (American Wire Gauge) rubber-coated wire, a 4.7K-ohm, 1/4-watt carbon resistor, and two test leads. For the leads, use a single Mouser test clip (Mouser No. 131C 301 or 302) attached to one end of the wire, and a test prod containing the resistor on the other.

To assemble the video probe, proceed as fol-

lows: Remove the cap from the test clip and strip 3/16 inch off each end of the wire. Solder one end to the post in the test clip, thread the other end through the hole in the cap, and snap on the cap. Next unscrew the plastic body of the test prod from the point and trim both leads of the resistor to a 3/16-inch length. Solder one resistor lead to the inside of the point. Thread the other end of the wire through the hole in the body and solder it to the other resistor lead; screw the body back onto the point.

(b) *The Logic Probe.* This is a test instrument designed for fast verification of digital IC outputs. It is small, convenient to carry, easy to read, and relatively inexpensive. The logic probe derives its power from the system under test; it has two power leads, one for connection to ground and the other to +5 volts DC. When the logic probe's tip is held against a digital signal point, three colored lamps in the tip will indicate the signal's condition or state, as follows:

- The red lamp lit indicates a high or logic level 1 (for TTL components, this is +2.4 to +5 volts)
- The white lamp lit indicates a low or logic level 0 (for TTL components, this is 0 to +0.8 volt)
- The blue lamp lit indicates that the signal is changing states
- No lamps lit indicate the grey region between 0 and 1 (for TTL this is between +0.8 and +2.4 volts)

A circuit shorted to ground will illuminate the white lamp and an open circuit will illuminate the red lamp.

The logic probe is readily available from electronic supply sources; a commercial model found satisfactory is the Kurz-Kasch model LP 520.

(c) *The Logic Pulser.* This test instrument is similar in size and shape to the logic probe, and it also derives its power from the system under test. When the logic pulser's tip is held against a digital signal point, the source and sink capabilities of the pulser override any IC output and the point is driven to the opposite logic level. If the point that the logic pulser is held against is low, pressing the switch on the side of the pulser will introduce a high pulse. Conversely, pulsing a high line will pull that line low momentarily.

During troubleshooting the logic pulser allows stimulation of in-circuit ICs with a shaped digital pulse. For example, a certain feature of the game may not be working and you suspect that a circuit is not receiving the necessary signal. Use the pulser to imitate that signal and if the circuit begins working, you have proved that the signal was in fact missing and you can begin tracking it down. This technique is very similar to jumping coils in electromechanical games such as pinball machines.

In addition to the regular "pulse" button, there is another switch mounted on the logic pulser. When this switch is set in the "rep" mode, the instrument pulses the digital signal point at a 5-Hz rate or 5 times per second. This extremely low rate is slow enough to allow watching events initiated by the pulser. Counter outputs, for example, are more easily observed when the counter is pulsed or clocked at this rate.

The logic pulser is also readily available from electronic supply sources; a commercial model found satisfactory is the Kurz-Kasch model HL 583.

(d) *Oscilloscope*. The most versatile test instrument, and also the most expensive, is the oscilloscope. The high-speed TTL integrated circuits used in video games produce fast-rise-time signals. The oscilloscope should have a 50-MHz bandwidth, dual trace and dual time base capability. These latter features allow examination of both input and output signals simultaneously, so that precise timing relationships can be checked. The oscilloscope should also have provision for internal or external sync.

Of the newer, solid-state oscilloscopes, a satisfactory model is the Tektronix 465.

(e) *VOM or Volt-Ohmmeter*. This common measuring instrument is extremely useful in video game troubleshooting. It can be used to check line voltage, transformer secondary windings, continuity, resistance, power supply voltages, and to some extent used for measurements in the analog circuitry.

One commercial model found satisfactory is the Simpson 260.

## 6.2.2 OPTIONAL TEST EQUIPMENT:

(a) *The Logic Comparator*. This test instrument's main benefit is that it can be used to check the functioning of an integrated circuit device while the device is still in place on the printed circuit board. The logic comparator performs the check by comparing the suspect ICs functioning with that of an identical-type reference IC mounted in the instrument itself. Suppose that the functioning of a type-74193 device on the PCB is suspected to be defective. First insert a program card with a known-to-be-good 74193 into the logic comparator, and then clip the comparator test leads onto the leads of the suspect device. If there are any logic state differences between the reference IC and the suspect IC under test, then an LED on the logic comparator will light up to indicate which output is not functioning correctly. Once a defective IC has been located, it should be replaced.

Logic comparators are readily available from electronic

supply sources.

(b) *Atari Universal Test Fixture*. In situations where a large number of video games are being serviced, investment in the Universal Test Fixture will be justified. This item of test equipment forms a test station for troubleshooting printed circuit boards after they have been removed from the game cabinet. The Universal Test Fixture has a full set of controls for operating the game and also has its own TV monitor. The game's PCB is plugged into an edge connector mounted on the side of the Fixture; with this arrangement the PCB is positioned in a convenient way for connecting probes and other test instruments.

A program card inserted into a receptacle in the top of Fixture takes the place of the game's interconnect wires. The program card thus sets up the Fixture for each particular game; the game's name is clearly printed on the program card itself.

With the Universal Test Fixture the method of troubleshooting via substitution of known-to-be-good parts is made fast and convenient. For example, suppose that the TV picture in a game is completely broken up and you want to determine whether the game or monitor is causing the problem. Remove the PCB and plug it into the Fixture's edge connector, and also insert the correct program card for that game. If the picture on the Fixture's monitor is correct, then you know that the problem lies in the game's monitor.

## 6.3 SPECIFIC TROUBLESHOOTING INFORMATION

The following subparagraphs give additional troubleshooting information about certain areas of the Jet Fighter game.

**6.3.1 ANTENNA STATIC MODIFICATION:** This subparagraph gives a procedure for modifying the antenna, a wire connecting via PCB edge connector pin 6 to the base of transistor Q4. Any signal on the antenna that brings Q4 into conduction will cause the Q latch (formed by transistors Q3 and Q5) to be reset. The operation of this circuit is described in detail in para. 3.4.15 of Section III of this manual. The purpose of the static modification feature is to prevent players from bringing the game into the play mode without having deposited coins into the game. Provided that the antenna wire has been adjusted to optimum length, this feature can make it impossible for a player to obtain a bonus game by inducing a static charge in the coin entrance plate or any other metal part of the game.

The antenna wire is approximately one foot long, with one end intentionally left not connected. When a static discharge occurs, an electric current is induced in this wire

and an impulse is transmitted to the Q latch circuit. This impulse resets the latch, turning off game credit and changing the game over to the attract mode. To test the static modification feature, touch the end of the antenna wire with your finger; the body usually has enough capacitance to trigger the circuitry. Sensitivity of the static modification feature can be adjusted by changing the length of the antenna wire. Lengthening the wire increases sensitivity, so that a lesser charge will turn off game credit. Cutting the wire shorter decreases sensitivity, so that a larger charge is required for triggering the circuit.

If there are problems with static charges accidentally shutting off the game credit, try cutting the wire shorter in increments of 1/2 inch at a time. Be aware, however, that if the antenna wire is cut too short, players may be able to obtain free game credit (bonus games) by inducing a static charge in the game.

**6.3.2 TV MONITOR:** The TV monitor is a self-contained unit housed in its own chassis. A trouble's cause may be narrowed down to the monitor—either by the substitution method using a known-to-be-good monitor, or by verifying presence of AC power to the monitor power supply and presence of the *correct* composite video signal. The entire monitor can then be removed from the game cabinet. Doing this facilitates troubleshooting steps, because all monitor components will then be accessible.

A schematic diagram of the monitor circuitry is included in Section VII of this manual. After disconnecting and removing the monitor from the game, standard TV troubleshooting techniques are adequate for locating causes of trouble. Additional servicing information is available from the monitor manufacturer (Motorola).

**6.3.3 COIN MECHANISM:** If a player inserts a coin and the game does not respond, first check the coin mechanism. If pressing the coin rejector button forces the rejector mechanism to return the coin, then examine the coin to make sure that it is genuine. If it is, then use a set of your own test coins (which should include both very new and very old, worn coins) to determine whether or not the player's coin is undersize or underweight. If your test coins are also returned, this indicates that servicing of the coin acceptor portion of the coin mechanism is called for. Generally the cause of this particular problem is an improperly adjusted magnet gate.

Inside the coin mechanism a magnet is used to test the metallic composition of the coin. Highly magnetic coins, such as those made of steel or iron, will be retained by the magnet and can be returned by actuating the wiper operating lever. Coins having comparatively high magnetic properties will be slowed down by the magnet, and will drop off the end of the rail short of the "accept" entrance

and be returned. Coins having little or no magnetic properties, such as brass or zinc coins, will pass through the magnetic field so fast that they will overshoot the "accept" entrance and be returned.

A magnetic gate adjusted with too large a gap may pass both genuine and counterfeit coins. An adjustment with too small a gap can lead to rejection of some or even all coins. Over a period of time, the screw that adjusts the magnet gate has a tendency to work loose, resulting in a gradual narrowing of the gate. At first, only the thickest (i.e., newest) coins are rejected. As time passes, more and more coins are rejected until finally player complaints lead to the calling of the game repairman.

If pressing the coin rejector button does not cause the coin to be returned, and if the game still does not respond, then check the coin mechanism to see if the coin is jammed inside.

If you are certain that the coin is genuine, and that the coin passes through the coin mechanism and into the cash box, then the lack of game response is probably due to some kind of electrical trouble. Check for signals at the electrical contacts of the coin mechanism before moving on to the harness and other parts of the circuitry.

## VII. Schematics, Drawings and Parts Lists

---

<i>Number</i>	<i>Title</i>
002602	Parts List, Top Assembly
A002602	Top Assembly (2 sheets)
002624	Parts List, Control Panel Assembly
A002624	Control Panel Assembly
002303-03	Parts List, Joystick Assembly
A002303-03	Joystick Assembly
004304-XXX	Parts List, Double Lite Switch Assembly
A004304-XXX	Double Lite Switch Assembly
004279	Harness Schematic
004308	Parts List, Electronics Tray Assembly
A004308	Electronics Tray Assembly
004254	Printed Circuit Board Schematic (4 sheets)
004254	Parts List, PCB Assembly (3 sheets)
A004254	Printed Circuit Board Assembly
[none]	Motorola XM501/701 Monitor Schematic



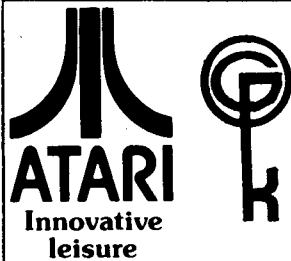

## PARTS LIST SPECIFICATION

Page 1 of 1

Drawn

Checked

*M.J. 6/10/75*

Mech. Eng.

Proj. Eng.

Elec. Eng.

REV.

E

Rev.	Description	Date	Apprv.	Rev.	Description	Date	Apprv.
C	PROD P/L (Second)	9/30/75	<i>U.S.</i>				
D	Rev per ECN 1676	10/5/75	<i>U.S.</i>				
E	Rev per ECN 1731	10/22/75	<i>U.S.</i>				

Item	Part Number	Qty.	DESCRIPTION
1	A002623	1	Cabinet Assembly
2	A003485	1	Light Box Assembly
3	A002624	1	Control Panel Assembly
4	A004286-01	1	R.F. Shielding Box
5	A004308	1	Electronics Tray Assembly
6	A003637	1	Coin Door Housing Assembly
7	92-006	1	19" T.V. Monitor
8	48-002	2	Speakers, 4" Motorola
9	003752	1	Black Cardboard Bezel
10	72-6820	4	Screws, Self-Tapping, #8 x 1 1/4, Ph. Pan Hd.
11	003892-01	1	Instruction Card
12	003892-02	1	Instruction Card
13	003887	1	Shipping Carton
14	75-5120N	13	Carriage Bolts, #10-24 x 1 1/4 Lg.
15	75-010S	23	#10 Flat Washer
16	75-911S	19	#10-24 Hex Nut
17	75-931S	4	#10-24 Wing Nut
18	002611	1	Bottom Plex Retainer
19	002610	1	Top Plex Retainer
20	003893	1	Play Field Plex Screen
21	002636	1	Lock Bar
22	82-404	2	# 1/4-20 x 3" Eye Bolt
23			
24	71-2114	1	Hudson Lock
25	003888	1	Side Panel, S/Screen Layout, R.H.
26	75-5132N	2	Carriage Bolts, #10-24 x 2"
27	004279	Ref	Harness Schematic
28	000869	2	Speaker, Aluminum Mesh
29	75-915S	2	# 1/4-20 Hex Nuts
30	75-035S	2	# 1/4 Flat Washer
31	003889	1	L.H. Side Panel S/Screen Layout
32	TM-027	1	Jet Fighter Technical Manual
33	75-5120B	8	Carriage Bolts, #10 - 24 x 1 1/4 Lg.
34	72-6812	8	Screws, Self Tapping, #8 x 3/4 Pan Hd Phil
35			
36	73-77004	8	Rivets, 3/16 x .68
37	73-7001	8	Mushroom Caps
38	004305	2	Cloud Decal

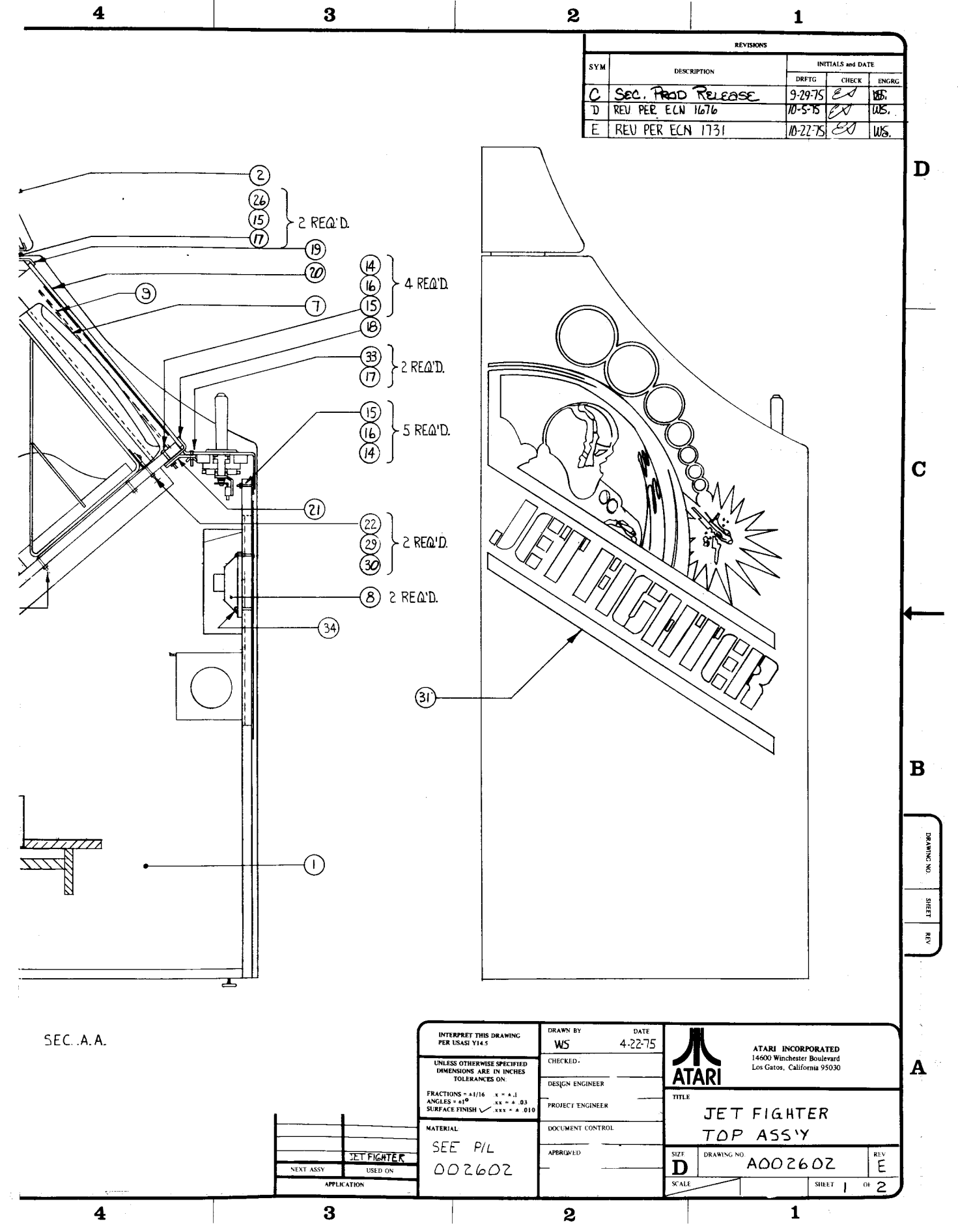
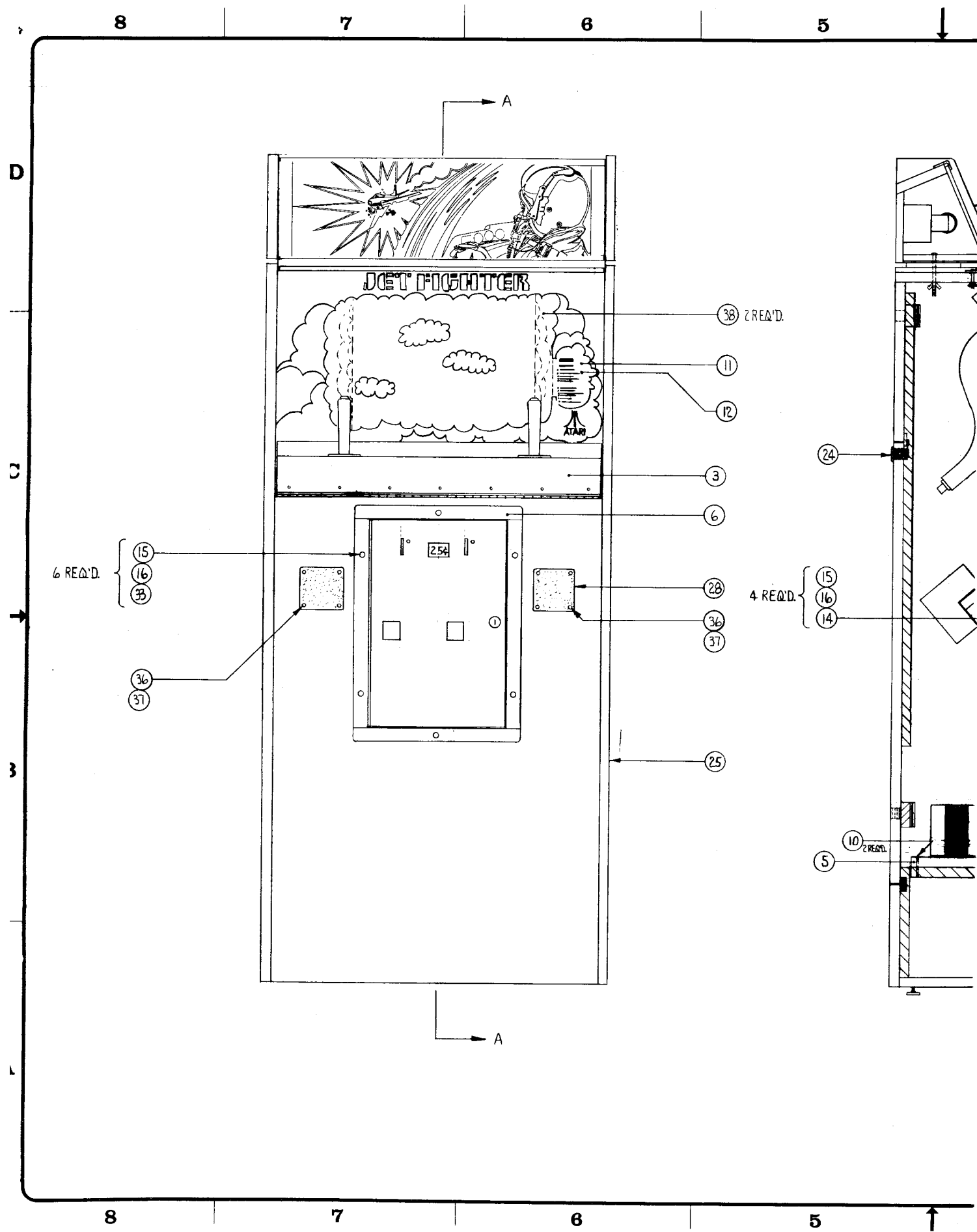

REVISIONS				
SYM	DESCRIPTION	INITIALS and DATE		
		DRFTG	CHECK	ENGRG
C	Sec. Prod Release	9-29-75	ES	WS
D	REV PER ECN 1676	10-5-75	ES	WS
E	REV PER ECN 1731	10-22-75	ES	WS

SEC. A.A.

INTERPRET THIS DRAWING PER USAS1 Y14.5  UNLESS OTHERWISE SPECIFIED DIMENSIONS ARE IN INCHES TOLERANCES ON: FRACTIONS - +1/16 x = +.1 ANGLES - ±10° xx = ±.03 SURFACE FINISH ✓ xxx = ±.010	DRAWN BY <b>WS</b>	DATE 4-22-75	ATARI INCORPORATED 14600 Winchester Boulevard Los Gatos, California 95030
	CHECKED: DESIGN ENGINEER PROJECT ENGINEER	DOCUMENT CONTROL APPROVED:	
MATERIAL SEE P/L 002602	APPLICATION JET FIGHTER	SIZE <b>D</b>	DRAWING NO. <b>A002602</b>
NEXT ASSY USED ON	SCALE	SHEET <b>1</b>	REV <b>E</b> OF <b>2</b>

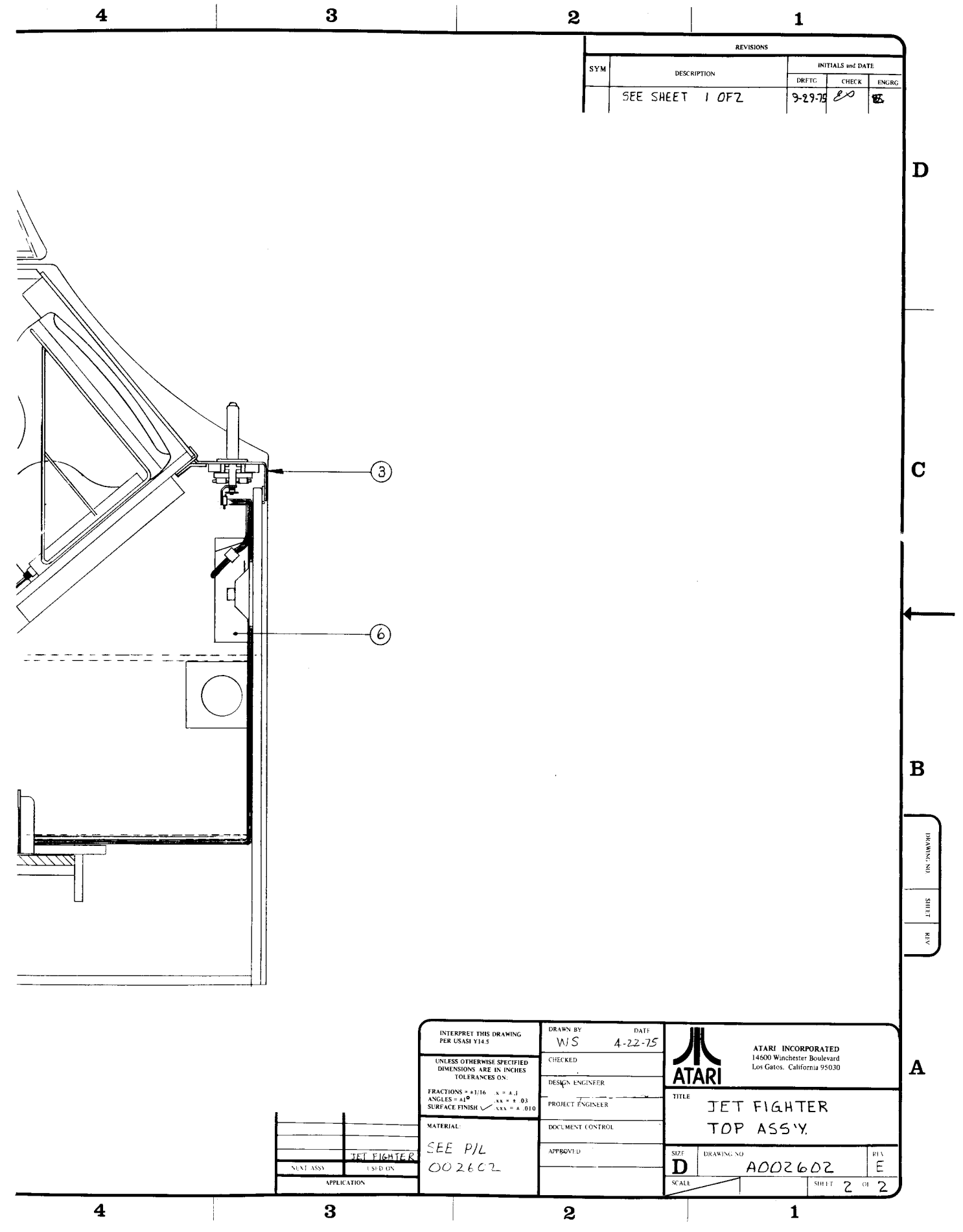
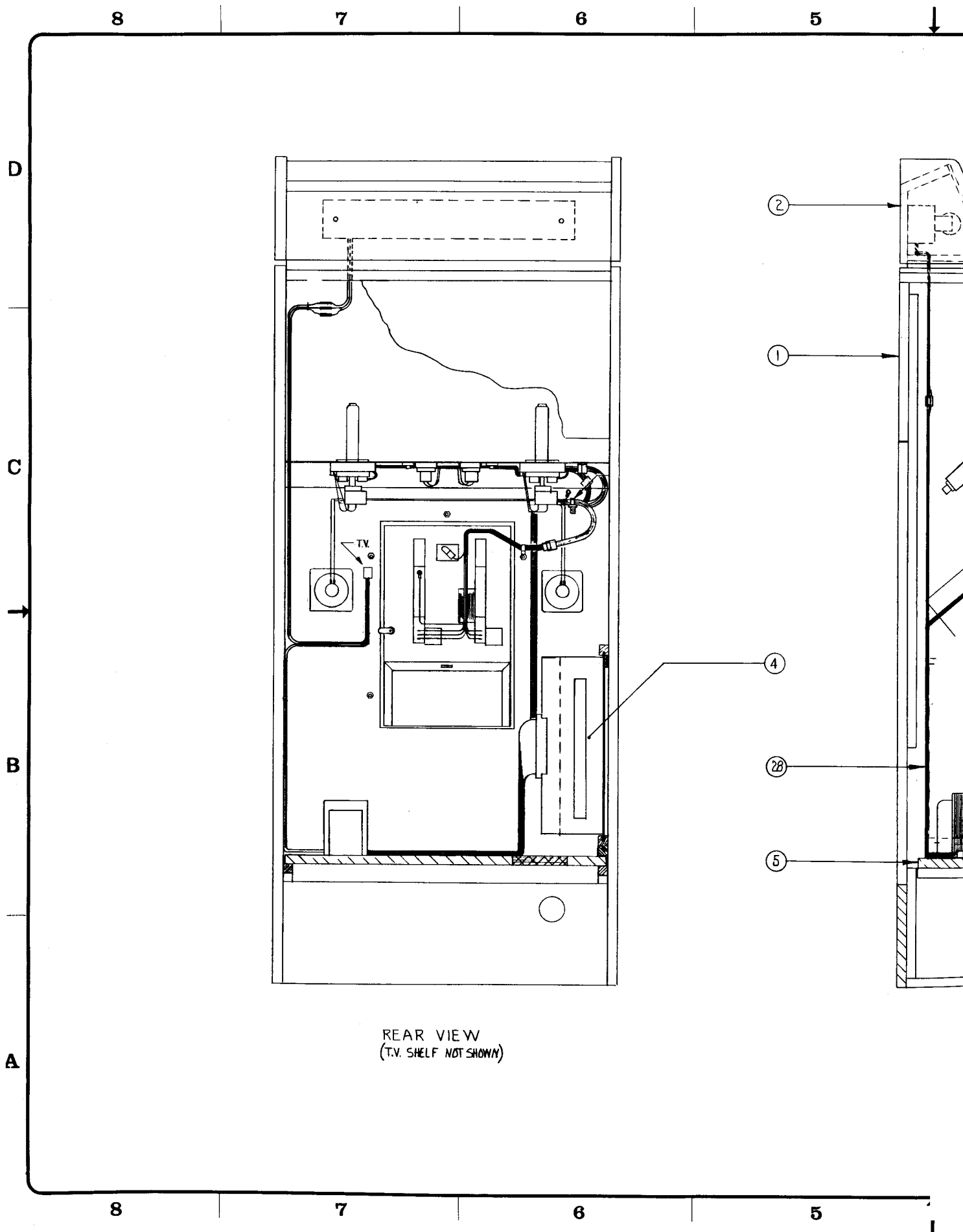

REVISIONS				
SYM	DESCRIPTION	INITIALS and DATE		
		DRFTG	CHECK	ENGRG
	SEE SHEET 1 OF 2	9-29-75	ES	ES

INTERPRET THIS DRAWING PER USAS 114.5		DRAWN BY WS	DATE 4-22-75	 ATARI INCORPORATED 14600 Winchester Boulevard Los Gatos, California 95030
UNLESS OTHERWISE SPECIFIED DIMENSIONS ARE IN INCHES TOLERANCES ON:		CHECKED	DESIGN ENGINEER	
FRACTIONS = +1/16    X = X.1		PROJECT ENGINEER	DOCUMENT CONTROL	TITLE JET FIGHTER TOP ASS'Y.
ANGLES = 45°    XX = X .03		APPROVED		SIZE D
SURFACE FINISH    XXX = X .010				DRAWING NO A002602
MATERIAL: SEE P/L 002602				SCALE
APPLICATION JET FIGHTER				SHEET 2 OF 2

DRAWING NO  
SHEET  
REV



ASSEMBLY TITLE / JET FIGHTER - CONTROL PANEL ASSY **P/L** 002624

PARTS LIST SPECIFICATION Page 1 of 1

Drawn	
Checked <i>M.J. 6/10/75</i>	Mech. Eng.
Proj. Eng.	Elec. Eng.
<i>9/29/75</i>	

REV.  
D

Rev.	Description	Date	Apprv.	Rev.	Description	Date	Apprv.
C	PROD REL	9/30/75	<i>W.S. 80</i>				
D	Rev per ECN 1698	10/14/75	<i>W.S. 80</i>				

Item	Part Number	Qty.	DESCRIPTION
1	002606	1	Aluminum Control Panel w/Hinge
2	A002303-03	2	Joystick Button Assembly
3	002624	2	Spacer Block
4			
5	004277-01	1	Electrical Harness
6	78-07002	2	Tie-Down, Adhesive Back Mount
7	72-6610	1	Screw, Self-Tapping, Sheet Metal, #6 x 5/8
8	A004304-09	1	Double Lite Switch Assy - One Player
9	A004304-10	1	Double Lite Switch Assy - Two Player

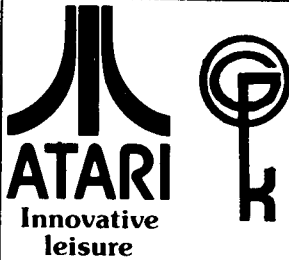

ASSEMBLY TITLE / JOYSTICK ASSEMBLY  
(UP, DOWN, RIGHT, LEFT, & FIRE) P/L 002303-03

PARTS LIST SPECIFICATION

Page 1 of 1

Drawn		REV.
Checked	Mech. Eng.	E
Proj. Eng.	Elec. Eng	

Rev.	Description	Date	Apprv.	Rev.	Description	Date	Apprv.
B	Prod Rel/ECN 1285	4/3/75	AK				
C	Rev per ECN 1333	4/21/75	AK				
D	Rev per ECN 1470	6/6/75	AK				
E	Rev per ECN 1503		AK				

Item	Part Number	Qty.	DESCRIPTION
1	002299	1	Button
2	002302	1	Spring Return
3	002298	1	Rod
4	002294	1	Bushing
5	002296	2	Washer, Return
6	002293	1	Hub
7	002297	1	Spacer Ring
8	003207	1	Switch Plate 11
9	002301	1	Bracket, Switch
10	002300	1	Actuator
11			
12	75-2412S	2	Screw, Mach, Rd Hd, Phil #4-40 x 3/4
13	75-044	2	Washer, Split Lock, #4
14	75-914S	2	Nut, Hex #4-40
15	75-991202	1	Nut, Hex, 1/4-28
16	75-019S	1	Washer, Flat, 5/16
17	75-06003	2	Washer, Belleville Spring
18	72-6410	8	Screw, Sheet Metal, Phil #4 x 5/8
19	72-6412	4	Screw, Sheet Metal, Phil #4 x 3/4
20	**65-081A	5	Switch
21	A003583-01	1	Handle Assembly w/Grip
22	75-912S	2	Nut, Hex, #2-56

Notes:

\*Optional Handle Grip See Dwg. No. 003092

\*\*Acceptable Substitutes

65-091A

65-101A

65-111A







ASSEMBLY TITLE	ASSEMBLY, ELECTRONICS TRAY	P/L	004308
----------------	----------------------------	-----	--------

PARTS LIST SPECIFICATION Page 1 of 1

Drawn <i>[Signature]</i>	
Checked	Mech. Eng.
Proj. Eng.	Elec. Eng.
	REV. A

Rev.	Description	Date	Apprv.	Rev.	Description	Date	Apprv.
A	PROD REL	9-30-75	<i>[Signature]</i>				

Item	Part Number	Qty.	DESCRIPTION
1	002621	1	Tray, Electronics
2	001551	1	Transformer
3	72-6608	14	Screw, Sht. Metal, Pan Hd., Phil., #6 x 1/2 Lg.
4	000622	1	Cover Transformer
5	79-3201	1	Fuse Holder
6	46-201132	1	Fuse, 1.25 AMP
7	90-3001	1	Filter, Power Line
8	68-001	1	A.C. Power Interlock Switch
9	000268	1	Bracket, Switch Mtg.
10	A004244	1	Power Cord 8', Assy
11	A002808-03	1	Interlock Switch Jumper
12	72-6812	4	Screw, SM, Pan Hd, Phil #8 - 3/4 Lg.
13	A004276	1	Harness
14	A001920	1	Harness, Voltage Selection
15	A001921-01	1	Shorting Block, 95V
16	A001921-02	1	" " 110V
17	A001921-03	1	" " 220V H
18	A001921-04	1	" " 220V L
19	A003100-04	1	Fuse Jumper Harness
20	000871	1	Label



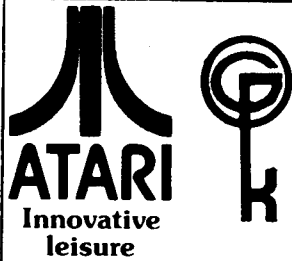

ASSEMBLY TITLE	JET FIGHTER PCB ASSEMBLY	P/L	004254
----------------	--------------------------	-----	--------

PARTS LIST SPECIFICATION Page 1 of 3

Drawn			
Checked	<i>[Signature]</i> 10/2/75	Mech. Eng.	
Proj. Eng.		Elec. Eng.	
			REV. E

Rev.	Description	Date	Apprv.	Rev.	Description	Date	Apprv.
A	PROD REL	10/2/75	<i>[Signature]</i>				
B	Rev per ECN 1683,1694	10/10/75	<i>[Signature]</i>				
C	Rev per ECN 1695	10/15/75	<i>[Signature]</i>				
D	Rev per ECN 1726,1727, &1740	10/28/75	<i>[Signature]</i>				
E	Rev per ECN 1747	11/3/75	<i>[Signature]</i>				

Item	Part Number	Qty.	DESCRIPTION	
1	10-5101	3	Res., 100 ohm, 1/2W	R8,R12,R14
2	10-5102	15	Res., 1K, 1/2W	R5,R6,R9,R10,R11,R16,R17,R34, ,R49,R51,R64,R65,R66,R74, R76
3	10-5103	31	Res., 10K, 1/2W	R4,R22,R23,R24,R25,R26,R28, R29,R30,R31,R32,R33,R35,R36 R38,R45,R46,R48,R50,R53,R55, R56,R57,R63,R67,R68,R71,R78, R79,R19,R89
4	10-5104	2	Res., 100K, 1/2W	R27,R90
5	10-5153	1	Res., 15K, 1/2W	R77
6	10-5221	1	Res., 220 ohm, 1/2W	R7
7	10-5222	9	Res., 2.2K, 1/2W	R62,R81-R88
8	10-5224	1	Res., 220K, 1/2W	R59
9	10-5331	4	Res., 330 ohm, 1/2W	R2,R3,R13,R44
10	10-5332	2	Res., 3.3K, 1/2W	R37,R47
11	10-5333	1	Res., 33K, 1/2W	R61
12	10-5471	6	Res., 470 ohm, 1/2W	R15,R18,R39,R40,R41,R42
13	10-5473	3	Res., 47K, 1/2W	R54,R60,R72
14	10-5474	2	Res., 470K, 1/2W	R73,R21
15	10-5563	2	Res., 56K, 1/2W	R58,R75
16	10-5681	1	Res., 680 ohm, 1/2W	R1
17	17-54P0	1	Res., 4 ohm, 10W	R80
18	19-315502	1	Trimpot, 5K	R69
19	19-315503	2	Trimpot, 50K	R52,R70
20	19-315105	1	Trimpot, 1M	R20
21	24-060257	3	Cap., 250mf, 6V	C18,C20,C48
22	24-160808	2	Cap., 8000mf, 16V	C16,C17
23	24-250105	2	Cap., 1mf, 25V	C23,C31
24	24-250106	1	Cap., 10mf, 25V	C4
25	24-250225	1	Cap., 2.2mf, 25V	C33
26	24-250227	2	Cap., 220mf, 25V	C30,C47
27	24-250478	1	Cap., 4700mf, 25V	C32
28	27-250103	4	Cap., 0.01mf, 25V	C5,C19,C21,C27
29	27-250104	30	Cap., 0.1mf, 25V	C1,C2,C3,C6,C7,C8,C9,C10,C11, C12,C13,C14,C15,C22,C24,C25, C26,C29,C34,C35,C36,C37,C38, C39,C40,C41,C42,C43,C46,C51

## PARTS LIST SPECIFICATION

Page 2 of 3

Item	Part Number	Qty.	DESCRIPTION
30	29-011	2	Cap., 0.22mf, 12V C44,C45
31	31-A14F	2	Diode, A14F D7,D8
32	31-MR501	2	Diode, MR501 D3,D4
33	31-1N914	4	Diode, 1N914 D1,D2,D5,D6
34	33-2N3644	1	Transistor, PNP, 2N3644 Q3
35	34-2N3565	3	Transistor, NPN, 2N3565 Q7,Q8,Q9
36	34-2N3643	5	Transistor, NPN, 2N3643 Q1,Q2,Q4,Q5,Q10
37	35-MCR106	2	SCR, MCR106 T1,T2
38	37-7400	9	I.C., 7400 C1,C3,D4,D8,F7,K1,L1,L5,P8
39	37-7402	2	I.C., 7402 D6,R7
40	37-7403	2	I.C., 7403 A7,A8
41	37-7404	5	I.C., 7404 C2,C7,F8,L8,M7
42	37-74H04	1	I.C., 74H04 R1
43	37-7408	5	I.C., 7408 E4,H3,H7,N3,N7
44	37-7410	4	I.C., 7410 E1,E5,F3,R2
45	37-7413	1	I.C., 7413 D9
46	37-7414	2	I.C., 7414 H9,J9
47	37-7420	2	I.C., 7420 C6,E2
48	37-7427	1	I.C., 7427 C5
49	37-7432	2	I.C., 7432 D1,K8
50	37-7437	1	I.C., 7437 E3
51	37-7474	14	I.C., 7474 B3,B6,B7,B8,C8,E7,F6,N4,P1, P4,P9,R3,R4,R9
52	37-7486	2	I.C., 7486 A1,K7
53	37-7490	1	I.C., 7490 D5
54	37-7492	1	I.C., 7492 P3
55	37-7493	4	I.C., 7493 A6,B5,M9,N9
56	37-74116	2	I.C., 74116 (9308) J3,L3
57	37-74153	6	I.C., 74153 A3,H8,L4,L9,M4,R6
58	37-74164	1	I.C., 74164 B1
59	37-74165	4	I.C., 74165 F4,H4,J4,K4
60	37-74175	4	I.C., 74175 D2,D3,F1,P5
61	37-74193	2	I.C., 74193 H6,J7
62	37-74279	1	I.C., 74279 E8
63	37-8225	2	I.C., 8225 (7489, 93403) M8,N8
64	37-9312	2	I.C., 9312 H1,N1
65	37-9316	22	I.C., 9316 (74161) A2,B2,B4,C4,D7,E6,F2,H2,J2, K2,L2,L6,L7,M2,M5,M6,N2,N5, N6,P2,P6,P7
66	37-9322	4	I.C., 9322 A5,J6,J8,K6
67	37-555	1	I.C., 555 K9
68	37-556	1	I.C., 556 F9
69	37-LM323K	1	I.C., LM323K, TO-3 Pkg
70	37-LM324	1	I.C., LM324 B9
71	37-LM380	2	I.C., LM380 B10,D10
72	37-7812	1	I.C., 7812 (LM340T-12), TO-220 Pkg
73	003629-02	1	Transistor Noise Source Q6

## PARTS LIST SPECIFICATION

Page 3 of 3

Item	Part Number	Qty.	DESCRIPTION
74	004250	2	J.F. Shell Rom J1,M1
75	004251	1	J.F. Single Player Rom R5
76	004252	1	J.F. Score Rom A4
77	004253- 02	1*	J.F. Picture & S.C. Rom A J5
78	004253- 01	1*	J.F. Picture & S.C. Rom B K5
79	004253-03	1*	J.F. Picture & S.C. Rom C F5
80	79-42116	4*	Socket, Solder, 16 pin I.C.
81	79-42424	1*	Socket, Solder, 24 pin I.C.
82	69-001	1	Slide Switch, DPDT
83	90-102	1	Xtal, 12.096 MHz
84	78-06001	1	Heatsink, TO-3 Pkg.
85	78-16005	1	Sil Pad
86	72-1610S	2	Screw, Mach., Pn Hd, Phil, 6-32 x 5/8"
87	75-056	2	Lockwasher, Internal Star, No. 6
88	75-916S	2	Nut, Mach, Hex, No. 6-32
89	72-1408S	2	Screw, Mach, Pn Hd, Phil, 4-40 x 1/2"
90	75-054	2	Lockwasher, Internal Star, No. 4
91	75-914S	2	Nut, Mach, Hex, No. 4-40
92	004255	1	Jet Fighter P.C.B.
93	75-016S	2	Washer, Flat, #6
94	34-2N5190	1	Transistor, NPN 2N5190 Q11
95	10-5151	1	Res., 150 ohm 1/4W R43
96	31-1N4001	1	Diode, 1N4001 D9
97	24-250226	1	Cap., 22mf, 25V C49
98	24-250505	1	Cap., 5mf, 25V C28
99	28-101101	1	Cap., 100pf C50

Note: Either use Items 78 & 77 with 2 of Item 80  
or use Item 79 with Item 81. Do not use all.

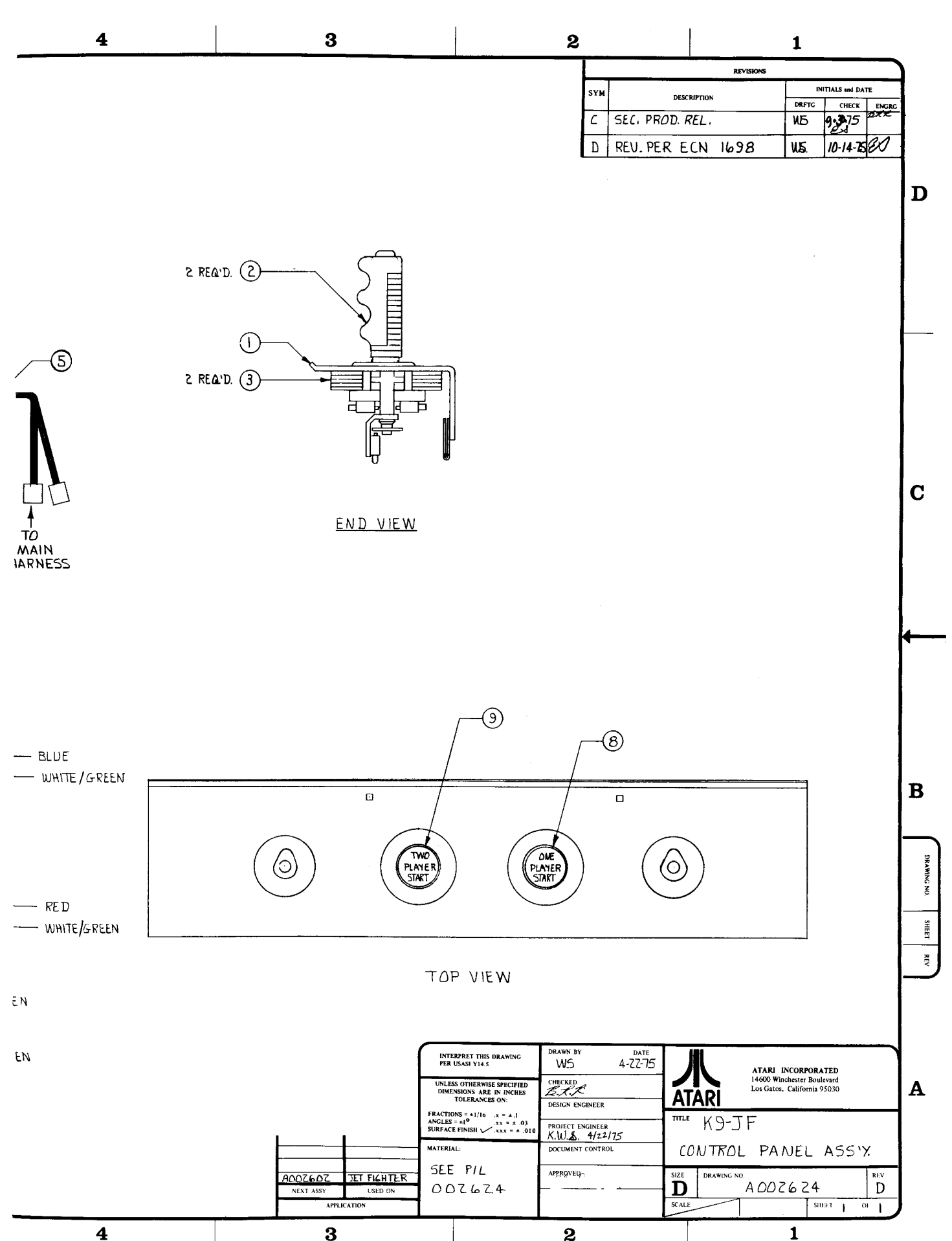
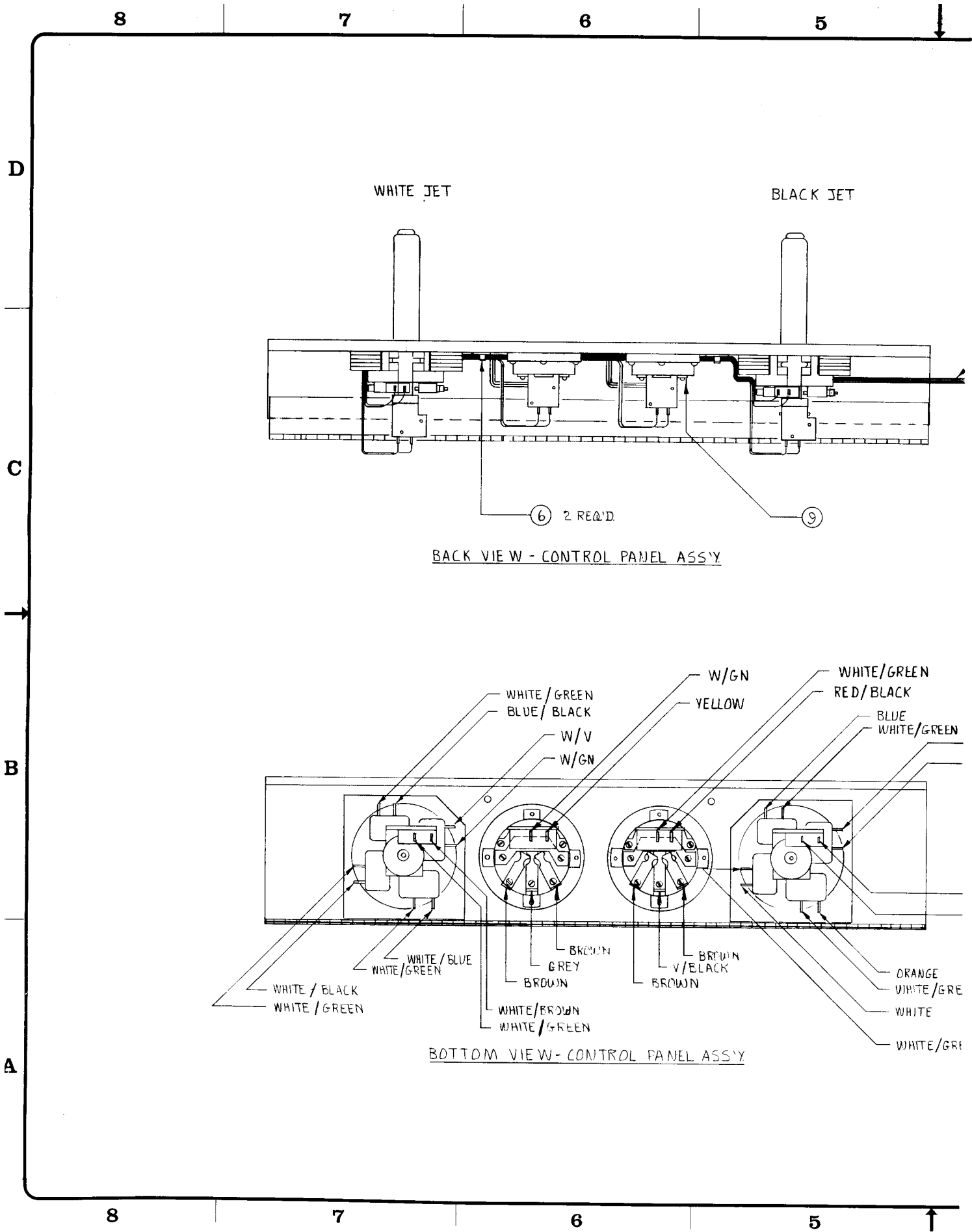

REVISIONS				
SYM	DESCRIPTION	INITIALS and DATE		
		DRAFTG	CHECK	ENGRG
C	SEC. PROD. REL.	WS	4-22-75	WS
D	REV. PER ECN 1698	WS	10-14-78	WS

INTERPRET THIS DRAWING PER USAS 14.5	DRAWN BY WS	DATE 4-22-75	 ATARI INCORPORATED 14600 Winchester Boulevard Los Gatos, California 95030
UNLESS OTHERWISE SPECIFIED DIMENSIONS ARE IN INCHES TOLERANCES ON:	CHECKED K.W.S.	DESIGN ENGINEER	
FRACTIONS = 1/16 .X = .1 ANGLES = 45° .XX = .03 SURFACE FINISH .XXX = .010	PROJECT ENGINEER K.W.S. 4/22/75	DOCUMENT CONTROL	TITLE K9-JF CONTROL PANEL ASS'Y
MATERIAL: SEE P/L 002624	APPROVED:		SIZE D
NEXT ASSY A002602 SET FIGHTER	USED ON		DRAWING NO A002624
APPLICATION			REV D
			SCALE
			SHEET 1 OF 1

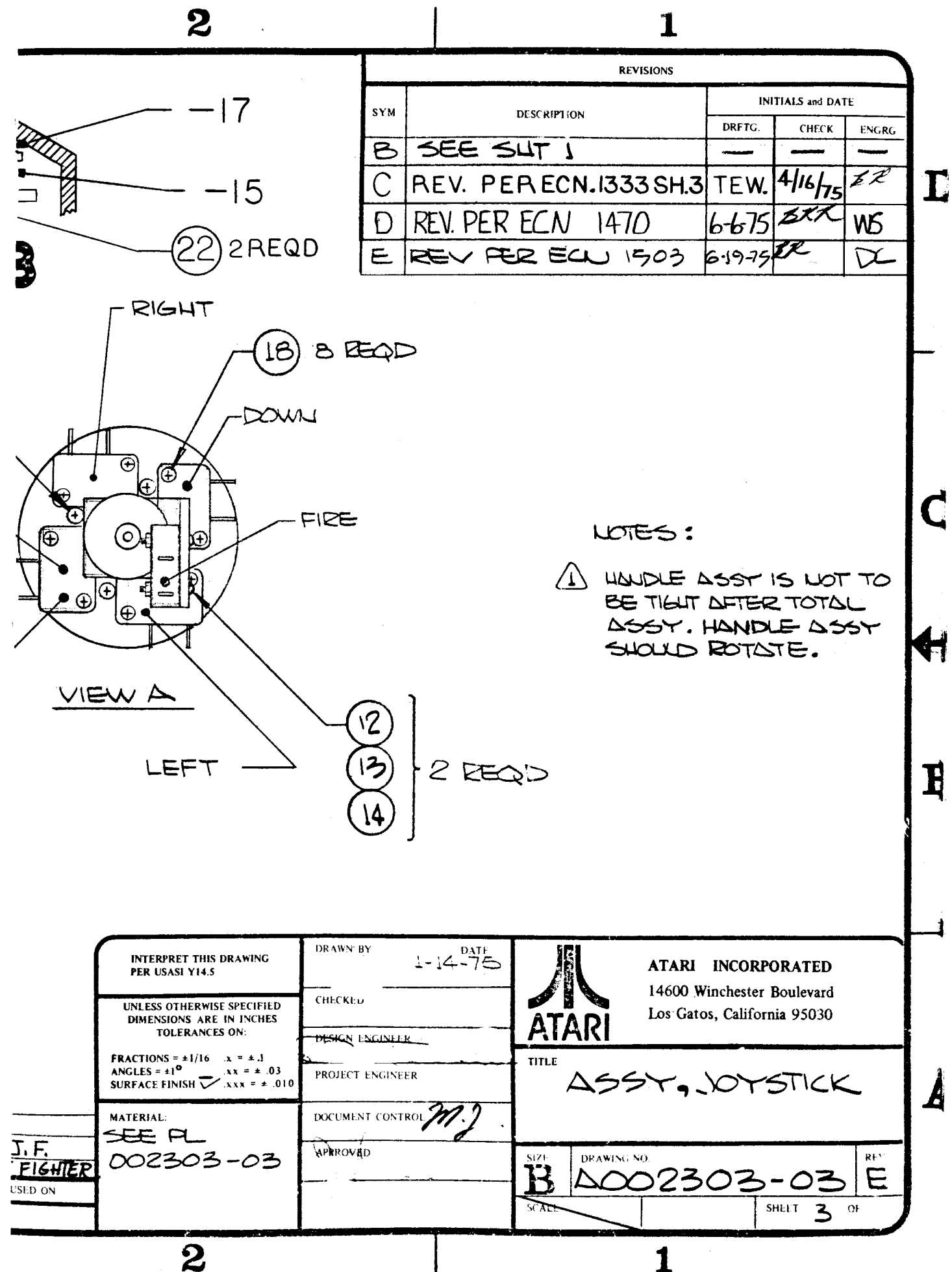
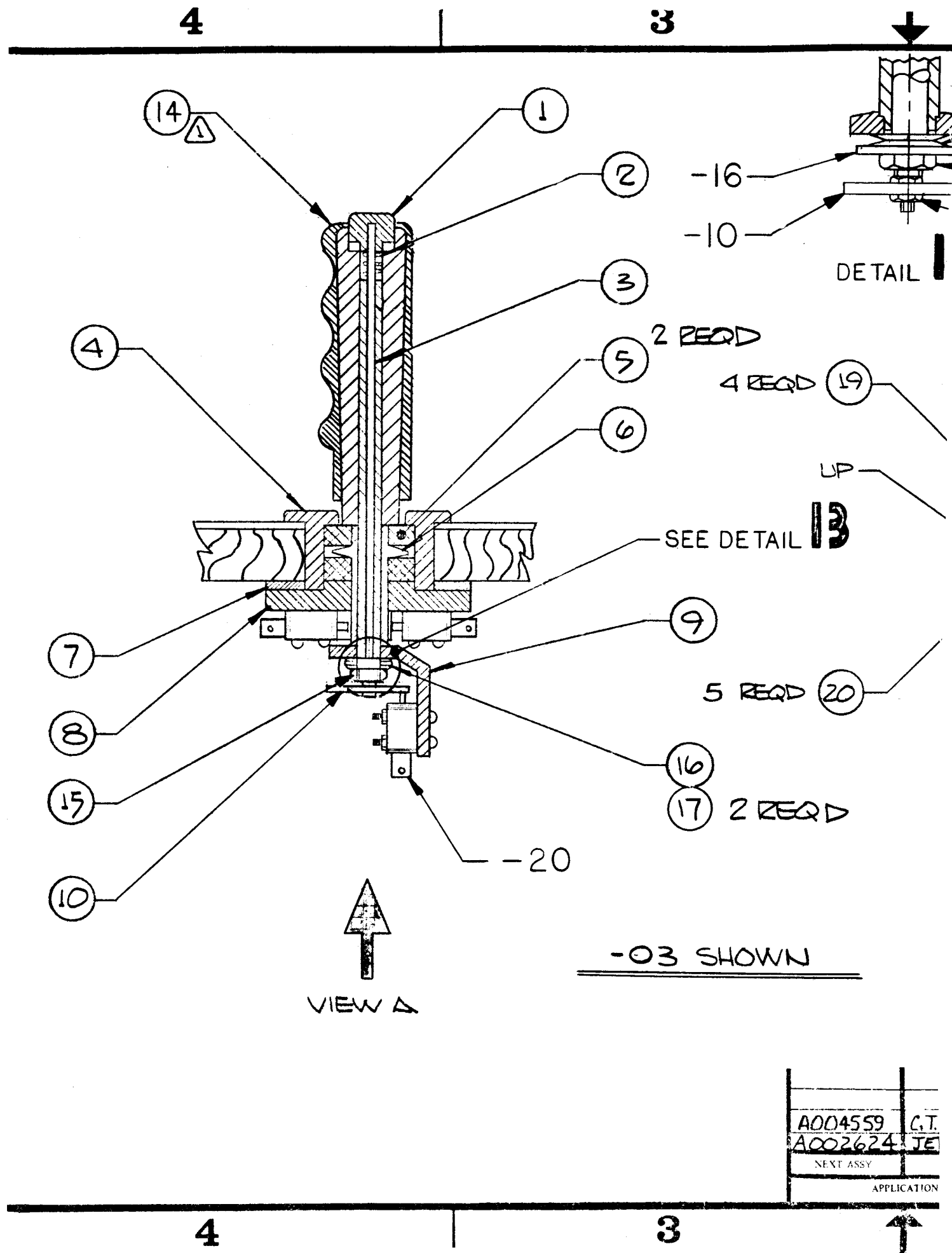

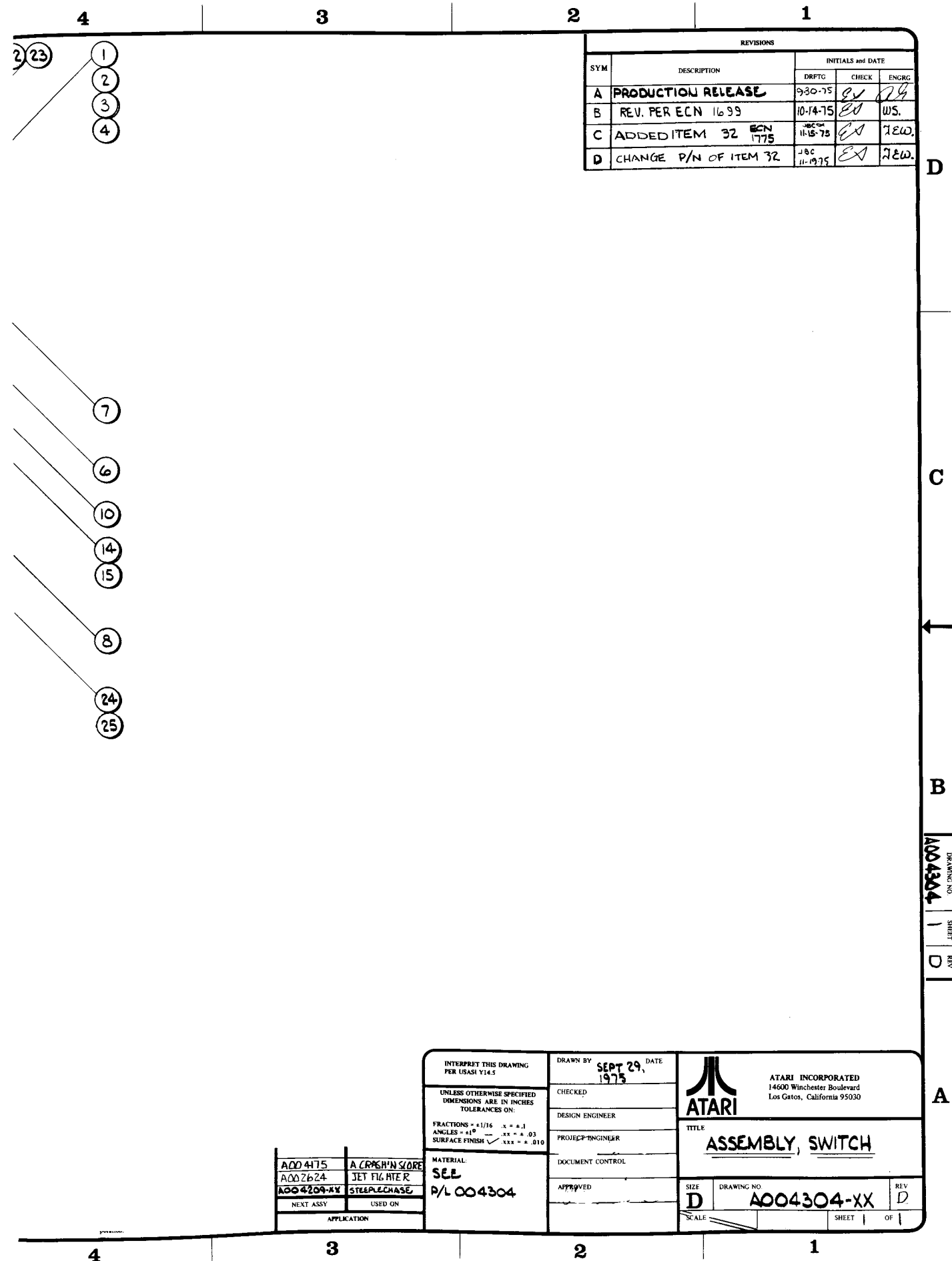
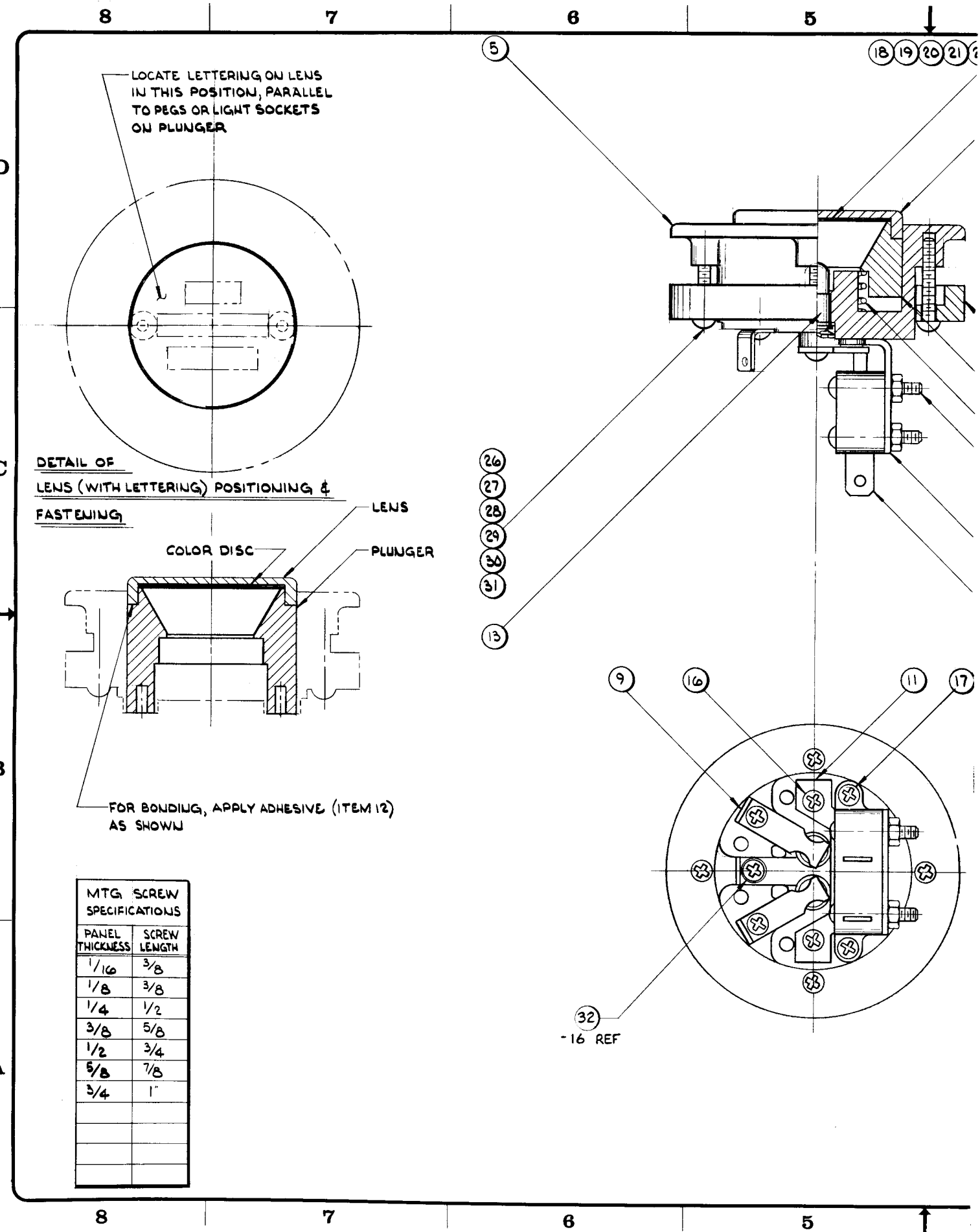

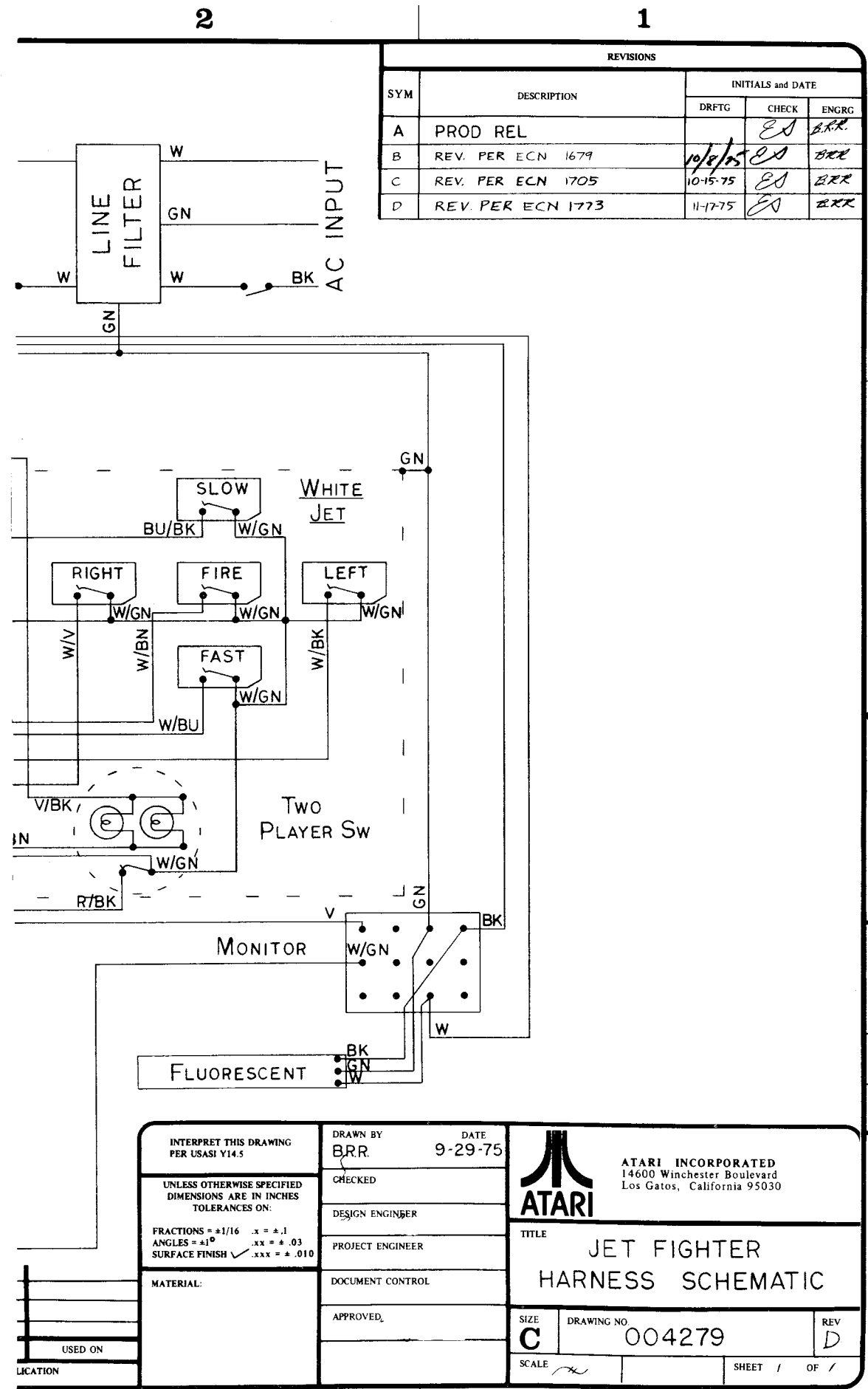
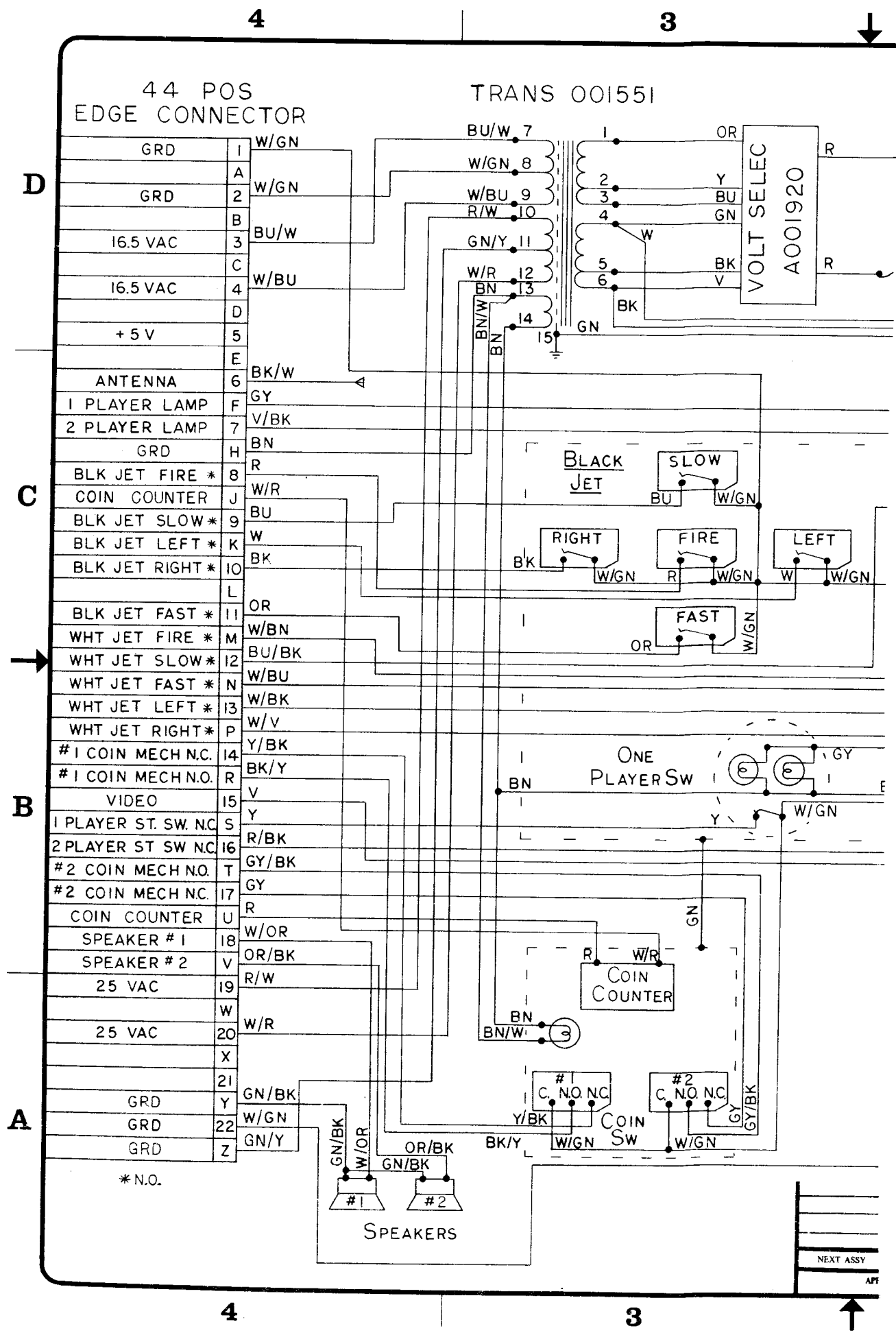

REVISIONS				
SYM	DESCRIPTION	INITIALS and DATE		
		DRFTG	CHECK	ENGRG
A	PROD REL		ES	BRR
B	REV. PER ECN 1679	10/8/75	ES	BRR
C	REV. PER ECN 1705	10-15-75	ES	BRR
D	REV. PER ECN 1773	11-17-75	ES	BRR

INTERPRET THIS DRAWING PER USASI Y14.5  UNLESS OTHERWISE SPECIFIED DIMENSIONS ARE IN INCHES TOLERANCES ON: FRACTIONS = +1/16 .x = .1 ANGLES = ±1° .xx = .03 SURFACE FINISH ✓ .xxx = .010	DRAWN BY BRR.	DATE 9-29-75
	CHECKED	
	DESIGN ENGINEER	
	PROJECT ENGINEER	
	DOCUMENT CONTROL	
	APPROVED	

**ATARI INCORPORATED**  
 14600 Winchester Boulevard  
 Los Gatos, California 95030

**TITLE**  
 JET FIGHTER  
 HARNESS SCHEMATIC

SIZE <b>C</b>	DRAWING NO. 004279	REV <b>D</b>
SCALE	SHEET 1 OF 1	

DRAWING NO.  
 SHEET  
 REV





REVISIONS			
SYM	DESCRIPTION	INITIALS and DATE	
		DRFTG	CHECK ENGRG
A	PRODUCTION RELEASE		
B	REV PER ECN 1683 1694	<i>MS</i>	<i>11/19/75</i>
C	REV PER ECN 1695	<i>MS</i>	<i>11/19/75</i>
D	REV PER ECN 1726, 1727 & 1740	<i>MS</i>	<i>10/24/75</i>
E	REV PER ECN 1747	<i>MS</i>	<i>11/5/75</i>

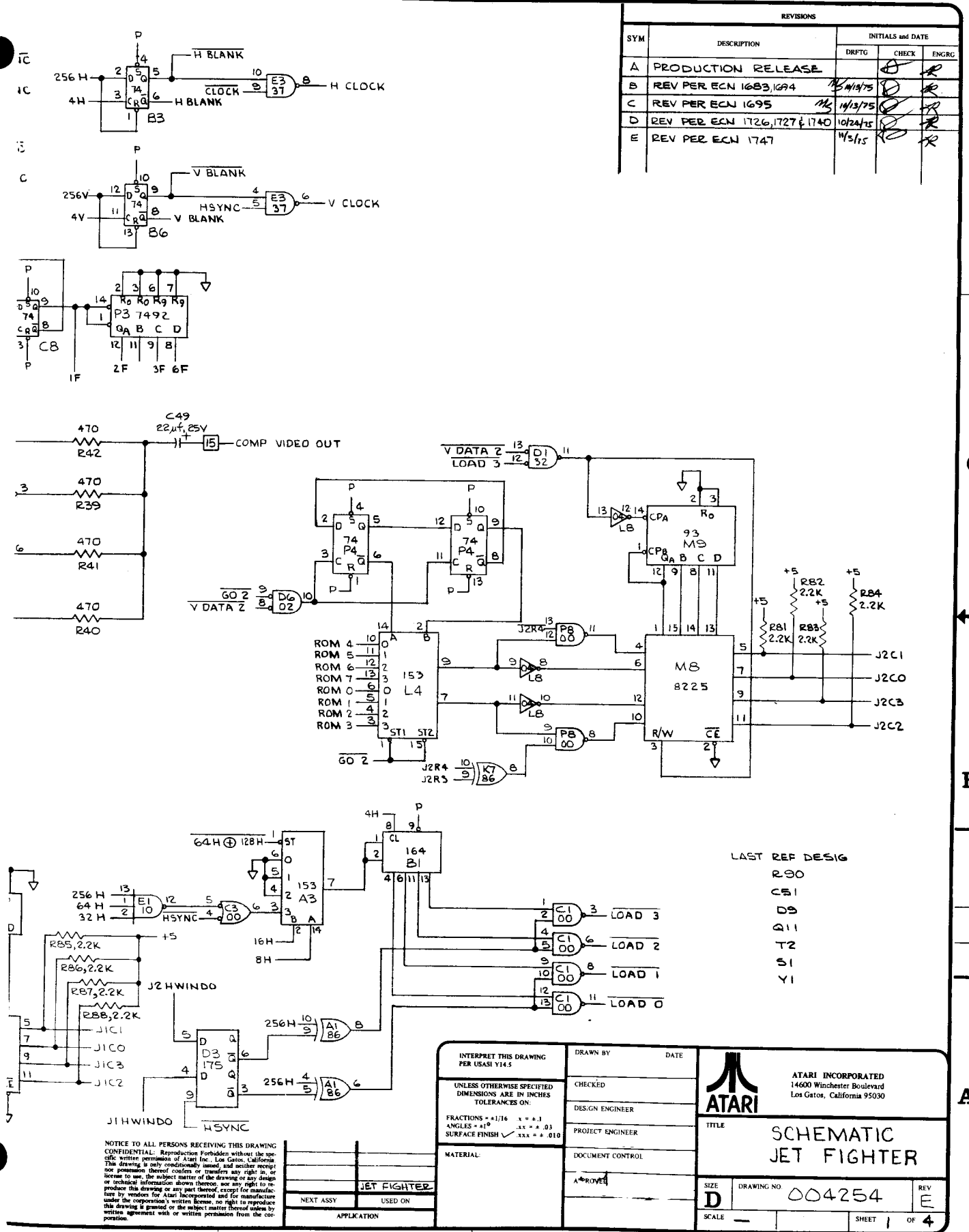

- LAST REF DESIG
- R90
  - C51
  - D9
  - Q11
  - T2
  - S1
  - Y1

INTERPRET THIS DRAWING PER USAS 1143 UNLESS OTHERWISE SPECIFIED, DIMENSIONS ARE IN INCHES. TOLERANCES ON: FRACTIONS = +.1/0    .X.XX = +.03 ANGLES = ±1°    SURFACE FINISH = XXX = .015		DRAWN BY: _____ DATE: _____ CHECKED: _____ DESIGN ENGINEER: _____ PROJECT ENGINEER: _____ DOCUMENT CONTROL: _____ APPROVED: _____
MATERIAL: _____ NEXT ASSY: _____ USED ON: _____ APPLICATION: _____		ATARI INCORPORATED 14600 Winchester Boulevard Los Gatos, California 95030 <b>ATARI</b> TITLE: <b>SCHEMATIC JET FIGHTER</b> SIZE: <b>D</b> DRAWING NO: <b>004254</b> REV: <b>E</b> SCALE: _____ SHEET 1 OF 4

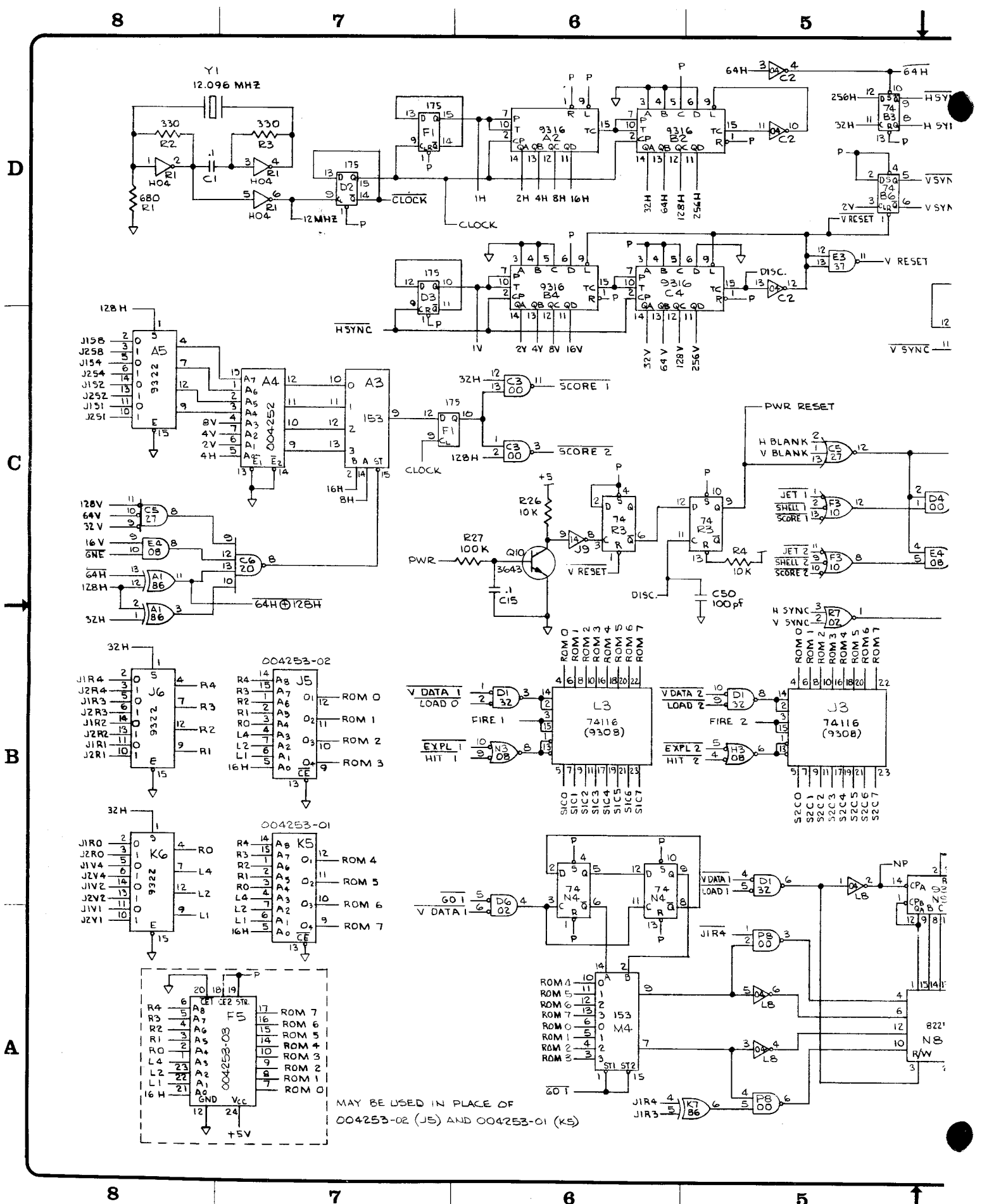

MAY BE USED IN PLACE OF 004253-02 (J5) AND 004253-01 (K5)

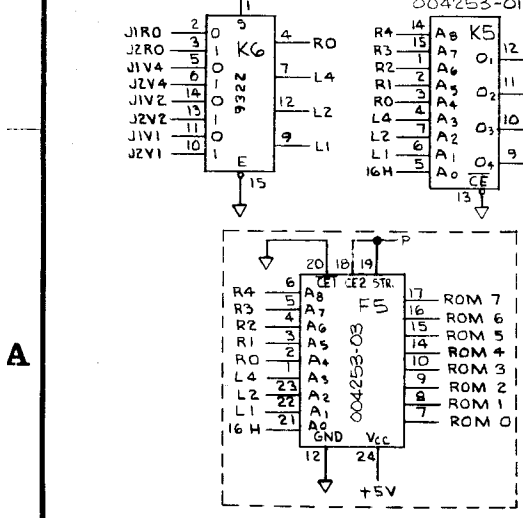

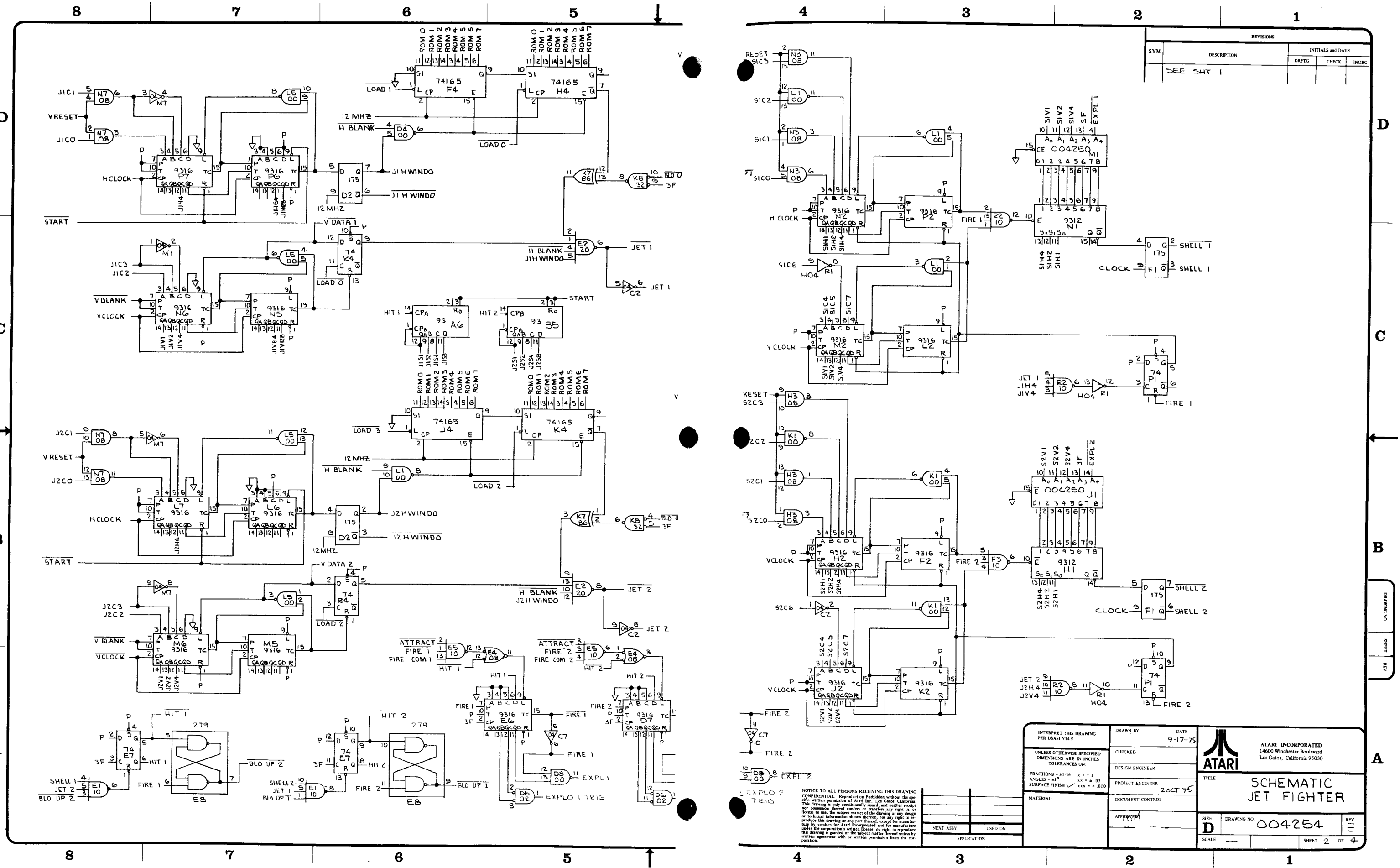

REVISIONS			
SYM	DESCRIPTION	INITIALS and DATE	
SEE SHT 1		DRAFT	CHECK ENGRG

INTERPRET THIS DRAWING PER USASI Y14.5 UNLESS OTHERWISE SPECIFIED DIMENSIONS ARE IN INCHES TOLERANCES ON: FRACTIONS = ±1/16 X = ±.1 ANGLES = ±1° XX = ±.03 SURFACE FINISH ✓ XXX = ±.010	DRAWN BY _____ DATE 9-17-75 CHECKED _____ DESIGN ENGINEER _____ PROJECT ENGINEER _____ DOCUMENT CONTROL _____	ATARI INCORPORATED 14600 Winchester Boulevard Los Gatos, California 95030
	TITLE <h3>SCHEMATIC JET FIGHTER</h3>	
MATERIAL _____ APPROVED _____ NEXT ASSY _____ USED ON _____ APPLICATION _____	SIZE D DRAWING NO. 004254 REV E SCALE _____ SHEET 2 OF 4	

NOTICE TO ALL PERSONS RECEIVING THIS DRAWING: CONFIDENTIAL. Reproduction Forbidden without the specific written permission of Atari Inc., Los Gatos, California. This drawing is not to be distributed, loaned, copied, or otherwise used for any purpose other than that for which it was prepared. No part of this drawing or any part thereof, nor any design or technical information shown thereon, nor any right to reproduce this drawing or any part thereof, may be reproduced or transmitted in any form or by any means, electronic, mechanical, photocopying, recording, or by any information storage and retrieval system, without the prior written agreement with or written permission from the corporation.

D  
C  
B  
A  
DRAWING NO. \_\_\_\_\_  
SHEET \_\_\_\_\_  
REV \_\_\_\_\_

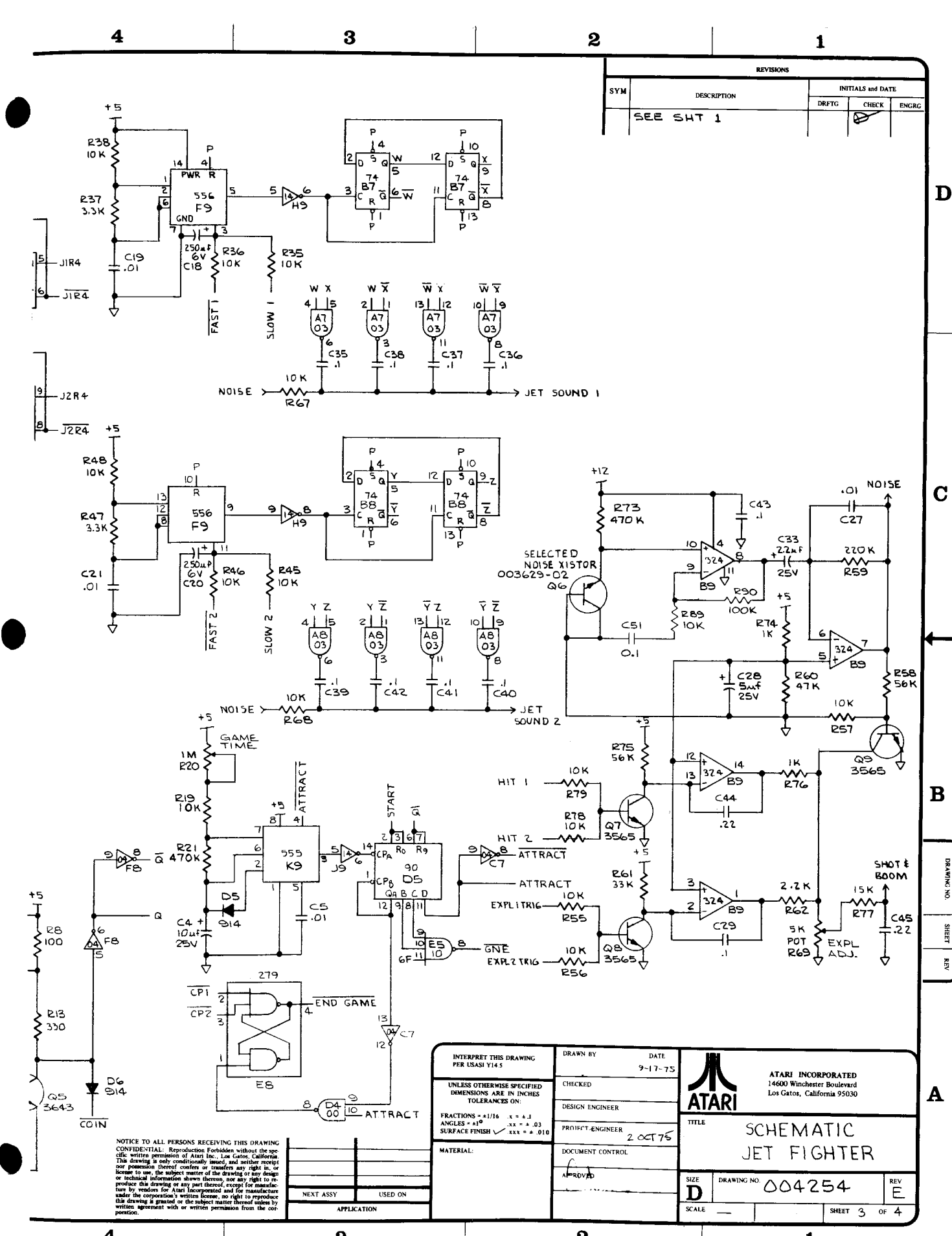
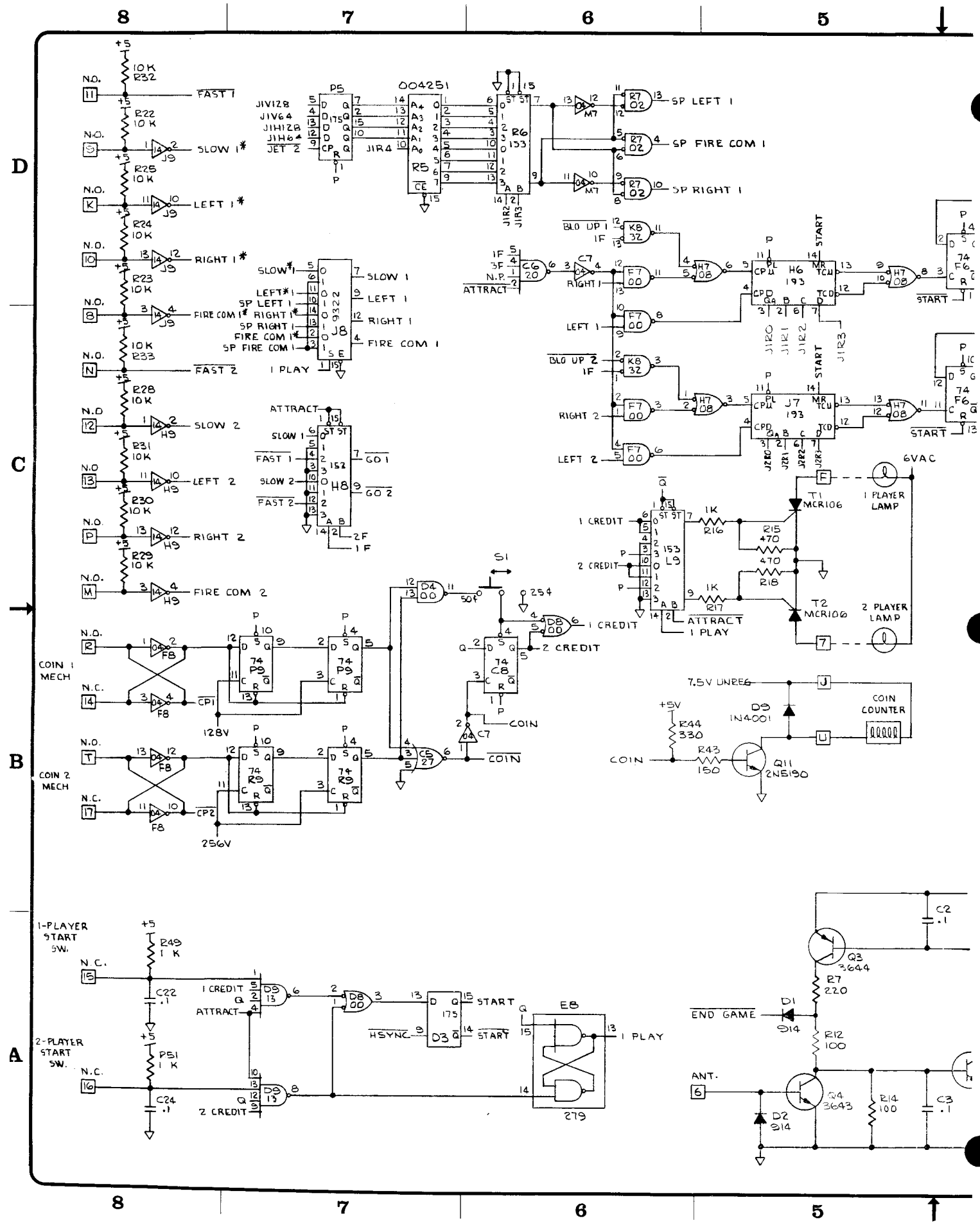

REVISIONS		
SYM	DESCRIPTION	INITIALS and DATE
SEE SHT 1		DRFTG CHECK ENGRG

INTERPRET THIS DRAWING PER ISASI Y14.5	DRAWN BY	DATE	 ATARI INCORPORATED 14000 Winchester Boulevard Los Gatos, California 95030
UNLESS OTHERWISE SPECIFIED DIMENSIONS ARE IN INCHES TOLERANCES ON:	CHECKED	9-17-75	
FRACTIONS = 1/16 1/32 1/64 ANGLES = 45° SURFACE FINISH = 32 X .010	DESIGN ENGINEER		
MATERIAL:	PRINT ENGINEER	2 OCT 75	
	DOCUMENT CONTROL		
	APPROVED		TITLE
			SCHMATIC JET FIGHTER
			SIZE
			D
			DRAWING NO.
			004254
			REV
			E
			SCALE
			SHEET 3 OF 4

NOTICE TO ALL PERSONS RECEIVING THIS DRAWING: CONFIDENTIAL. Reproduction Forbidden without the specific written permission of Atari Inc., Los Gatos, California. This drawing is only conditionally issued, and neither receipt nor possession thereof confers or transfers any right in, or license to use, the subject matter of the drawing or any design or technical information shown thereon, nor any right to reproduce this drawing or any part thereof, except for manufacture by vendors for Atari Incorporated and for manufacture under the corporation's written license. No right to reproduce this drawing is granted or the subject matter thereof unless by written agreement with or written permission from the corporation.

NEXT ASSY	USED ON
APPLICATION	

8 7 6 5

D  
C  
B  
A

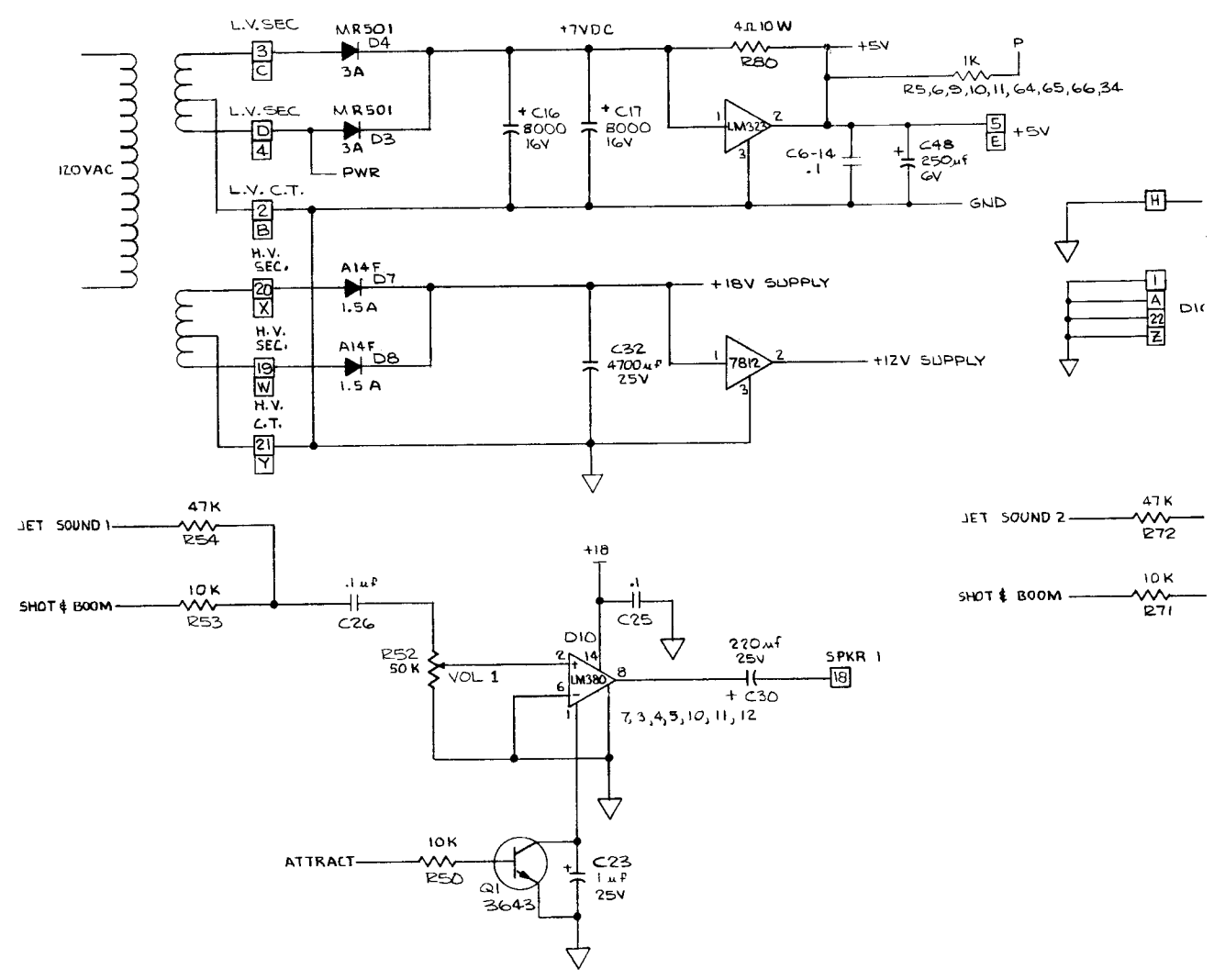

4 3 2 1

REVISIONS			
SYM	DESCRIPTION	INITIALS and DATE	
		DRFTG	CHECK ENGRG
SEE SHT 1			

GND FROM 6V TAP ON XFORMER  
DIGITAL GND

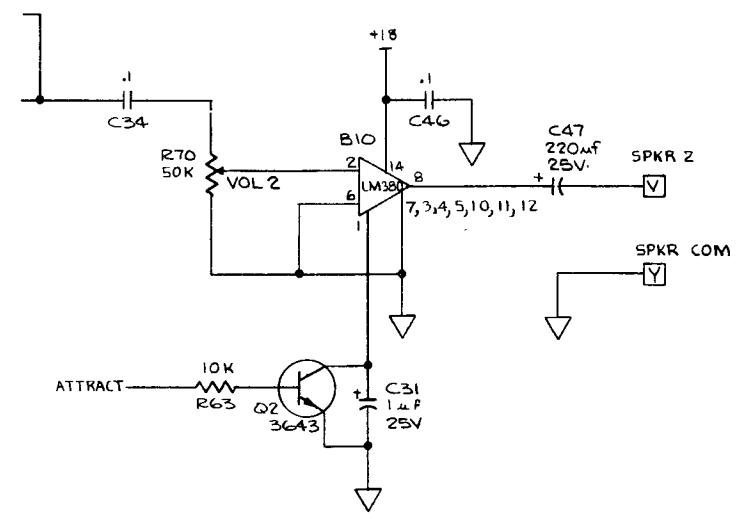

D  
C  
B  
A

8 7 6 5

4 3 2 1

NOTICE TO ALL PERSONS RECEIVING THIS DRAWING  
CONFIDENTIAL: Reproduction Forbidden without the specific written permission of Atari Inc., Los Gatos, California. This drawing is only conditionally issued, and neither receipt nor possession thereof confers or transfers any right to, or license to use, the subject matter of the drawing or any design or technical information shown thereon. No right to reproduce this drawing or any part thereof, except for manufacture by vendors for Atari Incorporated and for manufacture under the corporation's written license, no right to reproduce this drawing is granted or the subject matter thereof unless by written agreement with or written permission from the corporation.

INTERPRET THIS DRAWING PER USAS1 Y14.5	DRAWN BY	DATE	 ATARI INCORPORATED 14600 Winchester Boulevard Los Gatos, California 95030
UNLESS OTHERWISE SPECIFIED DIMENSIONS ARE IN INCHES TOLERANCES ON:	CHECKED	9-17-75	
FRACTIONS = +1/16 x = .1 ANGLES = 90° xx = .03 SURFACE FINISH ✓ .xxx = .010	DESIGN ENGINEER		TITLE
MATERIAL:	PROJECT ENGINEER	2 OCT 75	SCHEMATIC JET FIGHTER
	DOCUMENT CONTROL		SIZE
	APPROVED		D
NEXT ASSY			DRAWING NO
USED ON			004254
APPLICATION			SCALE
			—
			SHEET 4 OF 4

8 7 6 5

D

C

B

A

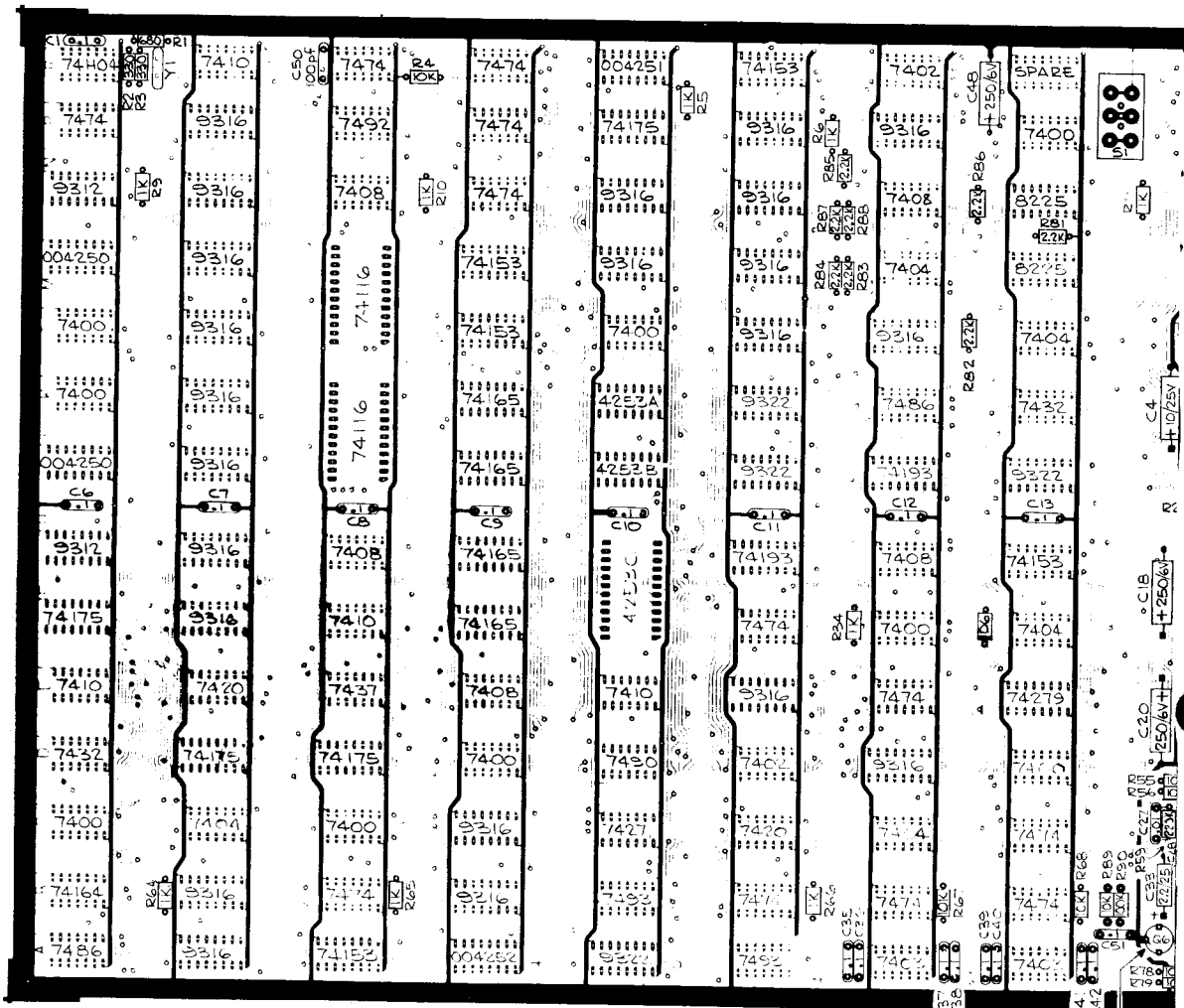

003629-02

4 3 2 1

REVISIONS				
SYM	DESCRIPTION	INITIALS and DATE		
		DRAFTG	CHECK	ENGRG
E	REV & REDRAWN PER ECN 1747	11/3/75		

D

C

B

A

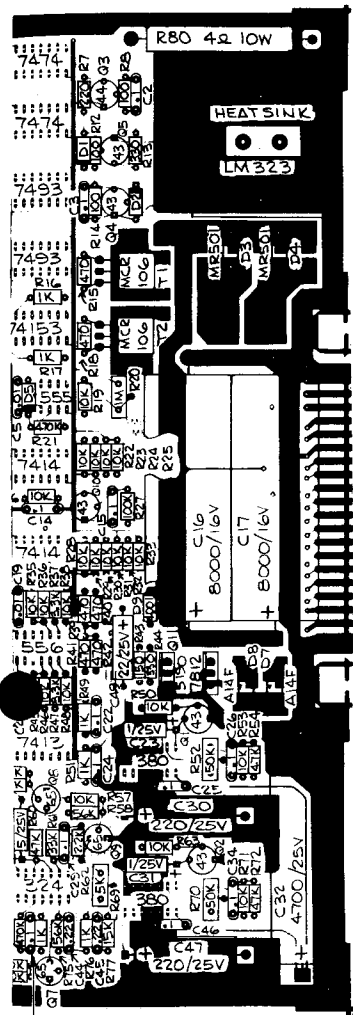

P73  
C42  
P74

- NOTES: UNLESS OTHERWISE SPECIFIED
1. ALL DIODES ARE 1N914.
  2. MOUNT 16 PIN SOCKETS IN POSITIONS M8 AND N8.
  3. USE ROMS 004253-02 (J5) AND 004253-01 (K5) WITH 16 PIN SOCKETS, OR USE 004253-03 (F5) WITH 24 PIN SOCKET AS AN ALTERNATE.

THIS ASSY TO BE USED WITH 004255 REVISION "D" P.C. BOARDS.

8 7 6 5

4 3 2 1

NOTICE TO ALL PERSONS RECEIVING THIS DRAWING  
 CONFIDENTIAL: Reproduction Forbidden without the specific written permission of Atari Inc., Los Gatos, California. This drawing is only conditionally issued, and neither receipt nor possession thereof confers or transfers any right to, or license to use, the subject matter of the drawing or any design or technical information shown thereon, nor any right to reproduce this drawing or any part thereof, except for manufacture by vendors for Atari Incorporated and for manufacture under the corporation's written license. No right to reproduce this drawing is granted or the subject matter thereof shall be written agreement with or written permission from the corporation.

INTERPRET THIS DRAWING PER USAS1 Y14.5	DRAWN BY	DATE
UNLESS OTHERWISE SPECIFIED DIMENSIONS ARE IN INCHES TOLERANCES ON:	CHECKED	10/31/75
FRACTIONS = +1/16 x = +.1	DESIGN ENGINEER	
ANGLES = 45° xx = +.03	PROJECT ENGINEER	4 NOV 75
SURFACE FINISH ✓ .xxx = +.010	DOCUMENT CONTROL	
MATERIAL:	APPROVED	
SEE P/L 004254		
NEXT ASSY	USED ON	
APPLICATION		

INTERPRET THIS DRAWING PER USAS1 Y14.5 UNLESS OTHERWISE SPECIFIED DIMENSIONS ARE IN INCHES TOLERANCES ON: FRACTIONS = +1/16 x = +.1 ANGLES = 45° xx = +.03 SURFACE FINISH ✓ .xxx = +.010		DRAWN BY CHECKED DESIGN ENGINEER PROJECT ENGINEER DOCUMENT CONTROL APPROVED		DATE 10/31/75	
MATERIAL: SEE P/L 004254		ATARI INCORPORATED 14600 Winchester Boulevard Los Gatos, California 95030		TITLE ASSEMBLY, JET FIGHTER P.C. BD	
SIZE D		DRAWING NO. A004254		REV E	
SCALE 1 : 1		SHEET 1 OF 1			

DRAWING NO. SHEET 1 OF 1