

INSTALLATION & SERVICE MANUAL



Before using this product, read this SERVICE MANUAL carefully to understand the contents stated herein. After reading this manual, be sure to keep it available nearby the product or somewhere convenient in order to be able to refer to it whenever necessary.

Manufactured in the UK by:



MANUFACTURING DIVISION (UK)

CONTENTS

1.	BEFORE USING THIS PRODUCT	4
1.1.	Inspections Immediately After Transporting The Product To The Location	5
2.	INTRODUCTION TO THIS SERVICE MANUAL	7
3.	INSTALLATION AND MAINTENANCE INSTRUCTIONS	8
3.1.	Handling And Installation Precautions	8
3.2.	Coin Handling	8
3.3.	Name Of Parts	9
3.4.	Accessories	10
3.5.	Shipping The Game Board	11
3.6.	Shipping The Media Board	13
3.7.	Assembly Instructions	14
3.7.1.	Installing The Billboard	15
3.7.2.	Installing The Floor And Leg Adjustor Adjustment	16
3.7.3.	Coin Handling Installation	18
3.7.3.1.	Wiring Connections	19
3.7.4.	Connection To The Power Supply	20
3.7.5.	Assembly Check	21
3.7.5.1.	CRT Test	21
3.7.5.2.	Memory Test	22
3.7.5.3.	Input Test	23
3.7.5.4.	Output Test	24
3.7.5.5.	Sound Test	24
3.8.	Moving The Machine	25
3.9.	Control Panel (Handle Mecha.) - 'HAPP' Type	26
3.9.1.	Replacing Volume	26
3.9.2.	Greasing – SEGA and HAPP types	28
3.9.3.	Replacement Of Spring	28
3.10.	Shift Lever	29
3.10.1.	Removing Shift Lever	29
3.10.2.	Switch Replacement	29
3.10.3.	Greasing	29
3.11.	Accelerator And Brake	30
3.11.1.	Removing The Accelerator And Brake	30
3.11.2.	Adjusting Or Replacing The Volume	32
3.11.3.	Greasing	33
3.12.	Replacement Of Fluorescent Lamps	34
3.12.1.	Front Fluorescent:	34
3.13.	Game Board	36
3.13.1.	Taking Out The Game Board	36
3.13.2.	Removing The GD-ROM Drive	38
3.13.3.	Composition of the Game Board	39
3.13.3.1.	Replacing The Main Board Battery	40
3.13.3.2.	Replacing The Media Board Battery Pack	41
3.14.	Troubleshooting	44
3.15.	Fuses	45
3.16.	PERIODIC CHECK AND INSPECTION	46
3.17.	Cleaning The Cabinet Surfaces	46
4.	CONTENTS OF GAME	47
4.1.	Basic Controls	48
4.2.	Game Outline	48
4.3.	Game Flow	49
4.3.1.	Versus Mode Entry	49
4.3.2.	Car Selection	49
4.3.3.	Transmission Selection	51
4.3.4.	Mode Selection	51
4.3.4.1.	OutRun Mode	51
4.3.4.2.	Heart Attack Mode	52
4.3.4.3.	Time Attack Mode	54
4.4.	Versus Play	56

4.4.1.	Versus Mode Game Play.....	56
4.4.2.	Special Versus Mode Commands.....	56
4.4.2.1.	No Handicap Mode.....	56
4.4.2.2.	Player Only Mode.....	56
4.5.	Gameplay Techniques And Secret Commands.....	57
4.5.1.	How to Drift.....	57
4.5.2.	Mid-game Quit Command.....	57
4.6.	Character Introductions.....	58
5.	MAINTENANCE INSTRUCTIONS.....	59
5.1.	Explanation Of Test Data And Display.....	59
5.2.	Internal Switches And Coin Meters.....	60
5.3.	System Test Mode.....	61
5.3.1.	RAM Test.....	62
5.3.2.	JVS Test.....	62
5.3.3.	Sound Test.....	63
5.3.4.	C.R.T Test.....	63
5.3.5.	System Assignments.....	64
5.3.5.1.	Coin Assignments.....	64
5.3.5.2.	Coin/Credit Setting (Coin Chute Common Type).....	65
5.3.5.3.	Coin/Credit Setting (Coin Chute Individual Type).....	66
5.3.5.4.	Manual Setting.....	67
5.3.5.5.	Sequence Setting.....	68
5.3.5.6.	Bookkeeping.....	69
5.3.5.7.	Backup Data Clear.....	69
5.3.5.8.	ROM BD Test.....	70
5.3.5.9.	Clock Setting.....	70
5.4.	Game Test Mode.....	71
5.4.1.	Input Test.....	72
5.4.2.	Output Test.....	73
5.4.3.	Drive Board Test.....	74
5.4.4.	Game Assignments.....	75
5.4.5.	Bookkeeping.....	77
5.4.6.	Backup Data Clear.....	79
5.5.	Network Play.....	80
6.	COIN MECH INSTALLATION AND CREDIT BOARD SET UP.....	81
6.1.	Introduction.....	81
6.1.1.	Price Of Play Settings UK.....	83
6.1.2.	Price Of Play Settings Euro.....	84
6.1.3.	Price Of Play Settings Austria-Czech-Denmark-Norway-Israel-France2.....	85
7.	DESIGN RELATED PARTS.....	86
8.	PARTS LIST.....	87
8.1.	Assembly Structure.....	87
8.2.	ORT-0002JUK TOP ASSY OTRUN 2 U/R.....	88
8.3.	ORT-1000JUK ASSY UR CABI PENT.....	89
8.4.	PTR-1110UK ASSY FRAMEWORK BLACK NEW.....	93
8.5.	PTR-1950UK ASSY SFMD BLACK (FLAT DOOR).....	94
8.6.	NOA-1200UK ASSY CRT COVER UK.....	95
8.7.	ORT-1400JUK ASSY FRONT PANEL PENT.....	96
8.8.	CTA-1150UK ASSY CC BOX WW.....	97
8.9.	ORT-4000UK ASSY ELEC.....	98
8.10.	PTR-1750UK ASSY SERVICE DOOR (BLACK).....	99
8.11.	ORT-4100UK ASSY MAIN BD.....	100
8.12.	ORT-1710UK ASSY AC UNIT (BLACK PENT).....	101
8.13.	ORT-20002UK ASSY CONTROL PANEL.....	102
8.14.	CTA-4200UK ASSY XFMR.....	104
8.15.	ORT-6001UK ASSY WIRE L.....	105
8.16.	NOB-6001UK ASSY WIRE L.....	105
8.17.	CTA-6002UK ASSY WIRE R.....	105
8.18.	OTR-INST-JUR ASSY INST KIT ORT PENT UR.....	106
8.19.	ORT-1250UK ASSY FLOOR SHORT.....	107
9.	APPENDIX A - ELECTRICAL SCHEMATIC.....	108

9.1. Wire Colours.....	108
9.2. Electrical Schematic	108

1. BEFORE USING THIS PRODUCT

To ensure the safe usage of the product, be sure to read the following before using the product. The following instructions are intended for the use of QUALIFIED SERVICE PERSONNEL ONLY. After carefully reading and sufficiently understanding the instructions should any activity be carried out on the product. Only qualified service personnel should carry out maintenance on the product.

Terms such as WARNING!, CAUTION, and IMPORTANT! Are used where an explanation is given which requires special attention, depending on the potential risk. SEGA is not responsible for injury or damage caused by use in a manner contrary to the instructions stated in this document. In order to prevent accidents warning stickers and printed instructions are applied in the places where a potentially hazardous situation relating to the product could arise. Be sure to comply with these warnings.



Indicates that mishandling the product by disregarding this warning will cause a potentially hazardous situation, which can result in death or serious injury.



Indicates that mishandling the product by disregarding this caution will cause a potentially hazardous situation, which can result in personal injury and or material damage.



This is cautionary information that should be complied with when handling the product. Indicates that mishandling the product by disregarding this will cause a potentially hazardous situation that may not result in personal injury but could damage the product.

Be sure to turn off the power and disconnect from the mains supply before working on the machine.

Ensure that the correct fuse(s) is fitted to the machine.

Details of the correct fusing of the machine are enclosed in the Service Manual.

Ensure that only qualified Service Engineers perform any maintenance work on the machine.

Specification changes, removal of equipment, conversion and/or addition, not designated by SEGA are not permitted and will invalidate this product's CE conformity.

The parts of the product also include any warning labels or safety covers for personal protection etc. A potential hazard will be created if the machine is operated while any parts have been removed. Should any doors, lids or protective covers be damaged or lost, do not operate the product. SEGA is not liable in any whatsoever for any injury and/or damage caused by specification changes not designated by SEGA.

Before installing the product, check for the Electrical Specification Sticker, SEGA products have a sticker on which the electrical specifications are detailed. Ensure that the product is compatible with the power supply voltage and frequency requirements of the location in which the machine is to be installed.

Install and operate the machine only in places where appropriate lighting is available, allowing warning stickers to be clearly read.

To ensure maximum safety for both customers and operators, stickers and printed instructions describing potentially hazardous situations are applied to places where accidents could occur. Ensure that where the product is operated has sufficient lighting to allow any warnings to be read. If any sticker or printed warning is removed or defaced, do not operate the machine, until it has been replaced by an identical item.

When handling the monitor, be very careful. (Applies only to product with monitor)

Some of the monitor (TV) parts are subject to high tension voltage. Even after turning off the power some components are still occasionally subject to high tension voltage. Monitor repair and replacement should be performed by qualified service engineers only.

In cases where commercially available monitors and printers are used only the contents relating to this product are stated in this manual. Some commercially available equipment has functions and reactions not stated in this manual. Read this manual in conjunction with the specific manual of such equipment.

Descriptions contained herein may be subject to change without prior notification.

The contents described herein are fully prepared with due care. However, should any question arise or errors be found please contact SEGA.

1.1. *Inspections Immediately After Transporting The Product To The Location*



- Only QUALIFIED SERVICE PERSONNEL should carry out inspection.

Normally, at the time of shipment, SEGA products are in a state to allowing usage immediately after transporting to the location. Nevertheless, an irregular situation may arise during transportation preventing this. Before turning on the power, check the following points to ensure that the product has been transported safely.

- Are there any dented parts or defects (cuts, etc.) on the external surfaces of the product.?
- Are castors and leg adjusters present and undamaged?
- Do the power supply voltage and frequency requirements meet with the local supply?
- Are all wiring connectors correctly and securely connected? Unless connected in the correct direction, connector connections cannot be made successfully. Do not insert connectors forcibly.
- Are all IC's of each IC BD firmly inserted?
- Does the power cord have any cuts or dents?
- Do fuses meet the specified rating?
- Are such units such as monitors, control equipment, IC BD, etc. firmly secured?
- Are all earth wires connected?
- Are all accessories available?
- Can all doors and lids be opened with the accessory keys and/or tools?

2. INTRODUCTION TO THIS SERVICE MANUAL

SEGA ENTERPRISES LTD., supported by its experience in electronic high technology of VLSI's, microprocessors etc. and with a wealth of experience, have for more than 30 years been supplying various innovative and popular games to the world market. This Service Manual is intended to provide detailed descriptions together with all the necessary information covering the general operation of electronic assemblies, electro-mechanicals, servicing controls, spare parts, etc. as regards this new SEGA product. This manual is intended for those who have knowledge of electricity and technical expertise especially in IC's, CRT's, microprocessors etc. Carefully read this manual to acquire sufficient knowledge before working on the machine. Should there be any malfunction, non-technical personnel should under no circumstances touch the internal systems. Should such a situation arise contact the nearest branch listed below, or our head office.

SEGA AMUSEMENTS EUROPE LTD./ SEGA SERVICE CENTRE

Suite 3a
Oaks House
12 - 22 West Street
Epsom
Surrey
United Kingdom
KT18 7RG

Telephone: +44 (0) 1372 731820

Fax: +44 (0) 1372 731849

3. INSTALLATION AND MAINTENANCE INSTRUCTIONS



IMPORTANT

- Only QUALIFIED SERVICE PERSONNEL should carry out installation and maintenance.

3.1. *Handling And Installation Precautions*

When installing or inspecting the machine, be very careful of the following points and pay attention to ensure that the player can enjoy the game safely.

The game must NOT be installed under the following conditions:

- Outside, the game is designed for indoor use only.
- In areas directly exposed to sunlight, high humidity, dust, excessive heat or extreme cold.
- In locations that would present an obstacle in the case of an emergency i.e. near fire equipment or emergency exits.
- On unstable surfaces or surfaces subject to vibration.
- Where liquids, other than routine cleaning, may come into contact with the game.

Important:

- Only Qualified Service Personnel should install this machine.
- Be sure to switch the supply power OFF and remove the mains supply plug from the machine before any work is carried out on the machine.
- Do not attempt to repair the PCB's (Printed Circuit Boards) yourself. This will void the warranty. The PCB's contain static sensitive devices that could be damaged.
- Always return a faulty part to your distributor with adequate packaging and protection.
- When removing the plug from the mains always grasp the plug not the cable.
- Do not use a fuse that does not meet the specified rating.
- Make sure all connections are secure before applying power.



IMPORTANT

- Ensure that the mains lead is not damaged. If the mains lead is damaged in any way there could be a danger of electric shock or a fire hazard.
- Ensure that the power supply is fitted with circuit protection. Using the power supply without circuit protection is a fire hazard.

3.2. *Coin Handling*

Standard Sega machines are fitted with a SR3 coin mechanism, however, as a service to our customers Sega machines can be supplied with no coin mechanism or door allowing the customer to fit a coin handling option from the approved list. Fit only the coin handling arrangements detailed below and follow the instructions provided in Section 6. Failure to fit the coin handling options detailed or failure to follow the installation instructions will render the machine, under the CE marking directive, void.

Approved coin handling options:

- Coin controls SR3
- Generic mechanical
- Mars (MS111B1 and ME115)
- SECI RM4-G20

3.3. Name Of Parts

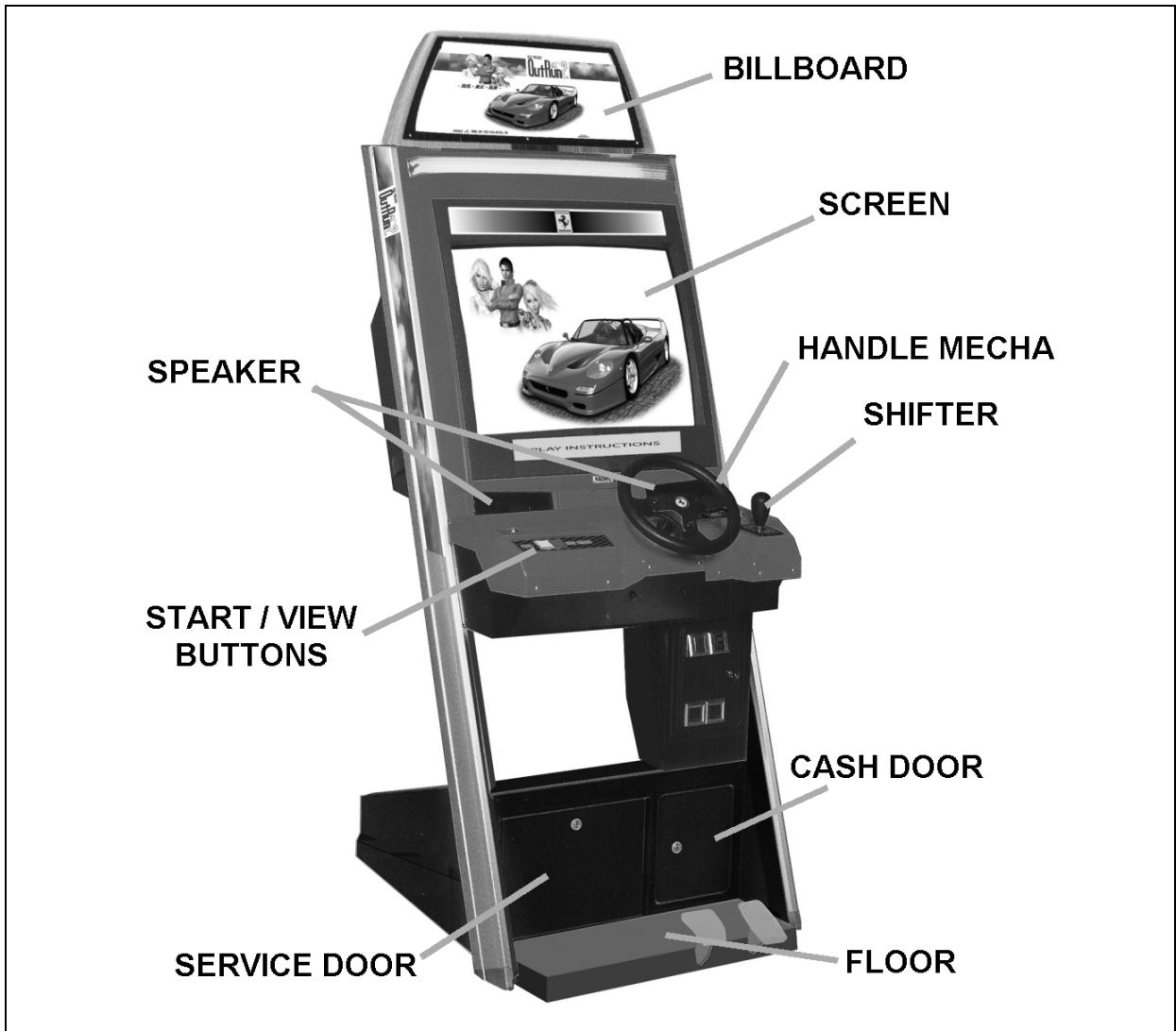

	Width (cm)	Length (cm)	Height (cm)	Approx Weight (Kg)
MAIN CABINET	76	105	180	165
FLOOR	63	26	10	8
BILLBOARD	76	17	31	N/A
WHEN ASSEMBLED	76	105	224	167

3.4. Accessories

The machine is supplied with an installation kit. Please ensure the following parts are supplied:

Item	Component Part	Description	Qty
1	NOA-1301X	BILLBOARD PLATE	1
2	ORT-1250UK	ASSY FLOOR SHORT	1
3	CTA-0001	JOINT BRKT L	1
4	CTA-0002	JOINT BRKT R	1
8	ORT-0001UK	DISPLAY CARD ORT UR	1
9	NOA-1302UK	BILLBOARD SHEET	1
14	ORT-0003UK	PLAY INSTR SH A MULTI	1
18	420-3129-P	SERVICE MANUAL PENT 31K	1
19	SAECE-XXX	DECLARATION OF CONFORMITY	1
101	514-5078-5000	FUSE 5X20 CERAMIC SB 5000mA	1
201	030-000820-SB	M8X20 BLT W/S BLK	2
202	068-852216-0B	M8 WSHR 22OD FLT BLK	2
203	008-T00412-0B	M4X12 TMP PRF TH BLK	5
402	420-6796-01UK	SERVICE MANUAL ORT UR	1
403	420-6620UK	SERVICE MANUAL GD ROM SYSTEM	1
406	OS1019	SELF SEAL BAG 9X12.3/4	1
407	PK0346	INST KIT BOX ORT	1
408	PK0061	BUBBLE WRAP LARGE 1.5M X 45M	0.025
409	220-5484-H	VOL 5-K-OHM HAPP 50-8026-00	1
411	540-0006-01	WRENCH M4 TMP PRF	1
412	540-0007-01	WRENCH M5 TMP PRF	1
413	540-0009-01	WRENCH M8 TMP PRF	1
414	540-0015-01	WRENCH M6 TMP PRF	1

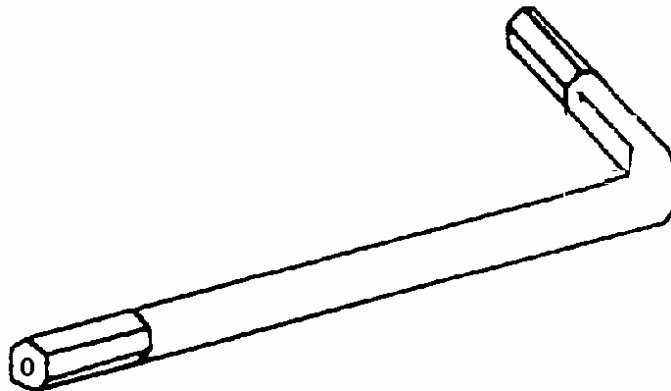

Items 101 & 102 - Tamperproof TORX wrench.

3.5. Shipping The Game Board

 <p>STOP IMPORTANT</p>	<p>Replacement or repair of the Game Board (Chihiro) for this product should be undertaken at the appropriate repair centre. Be sure to follow the specifications below when requesting repairs/sending the board to the repair centre. Not following the specifications may result in the board not being accepted or in extra charges being made.</p> <ul style="list-style-type: none">• Put the game board in the carton box as is. Do not carry out any disassembly or part removal other than that specified.• Follow the procedure and instructions regarding direction below when placing the Game Board in the carton box.• When packing the game board with the Media Board attached, do not remove the Key Chip.• When packing the game board with the Media Board detached, be sure to include the AVIP Cable.• When packing, attach the accessory stickers in the specified places on the Game Board and carton box.
---	---

INSTRUCTIONS

1. Wrap the Chihiro Board in a plastic bag.
2. Place it on top of the bottom surface cushioning material. Turn the Filter Board to face the side with the three honeycomb buffers. Packing it in the opposite direction may cause damage to the Filter Board.
3. Insert corrugated cardboard into the space between the lateral honeycomb buffers of the bottom surface cushioning material and stow the AVIP cable inside.
4. Place the Chihiro Board wrapped in the bottom surface cushioning material into the carton box. Use the handles on the bottom surface cushioning material.
5. Place the upper surface cushioning material on top of the Chihiro Board. Be sure to align it in the right direction, as it will not fit otherwise.
6. Close the top of the carton box and seal it tightly with adhesive tape.

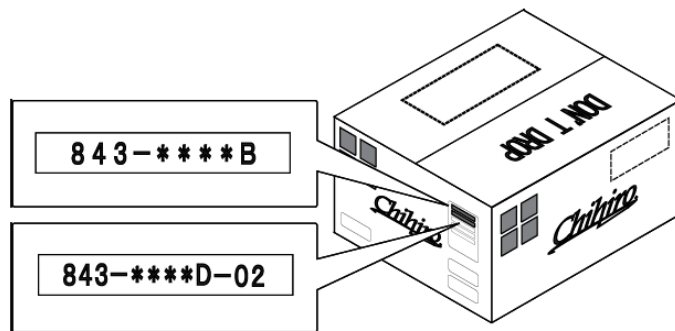
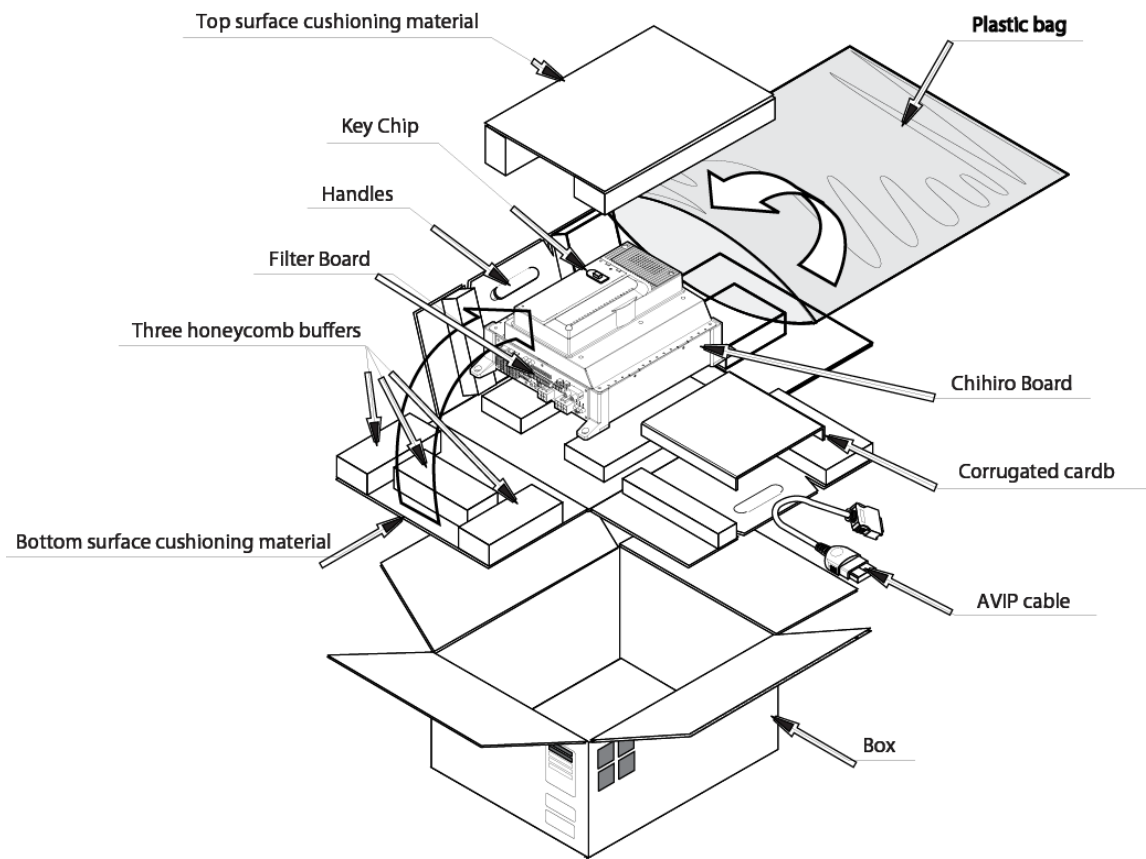

3.6. Shipping The Media Board

When sending the Media Board for repairs, follow the specifications below and request repairs or send the Board to your retailer/the repair centre.

Not following the specifications may result in the board not being accepted or in extra charges being made. Also, mistaken handling can damage or result in loss of parts.

- Be sure to use the special purpose carton box included with this product.
- Do not remove the Key Chip. Send the board with the Key Chip attached.
- Undo the 10 screws holding the Media Board to the Main Board and pack the Media Board. Do not carry out any disassembly or part removal other than that specified in this manual.
- Pack the Media Board in the special purpose carton box as shown in the explanatory diagram.
- The packing material in the carton box has a shock absorbing function. Be sure to use it when packing. Do not bend or fold the material in a direction other than that shown on the diagram.
- Do not pack any wires, cables, or screws together with the Board.
- Be sure to attach the special purpose carton box accessory sticker "843-****B."

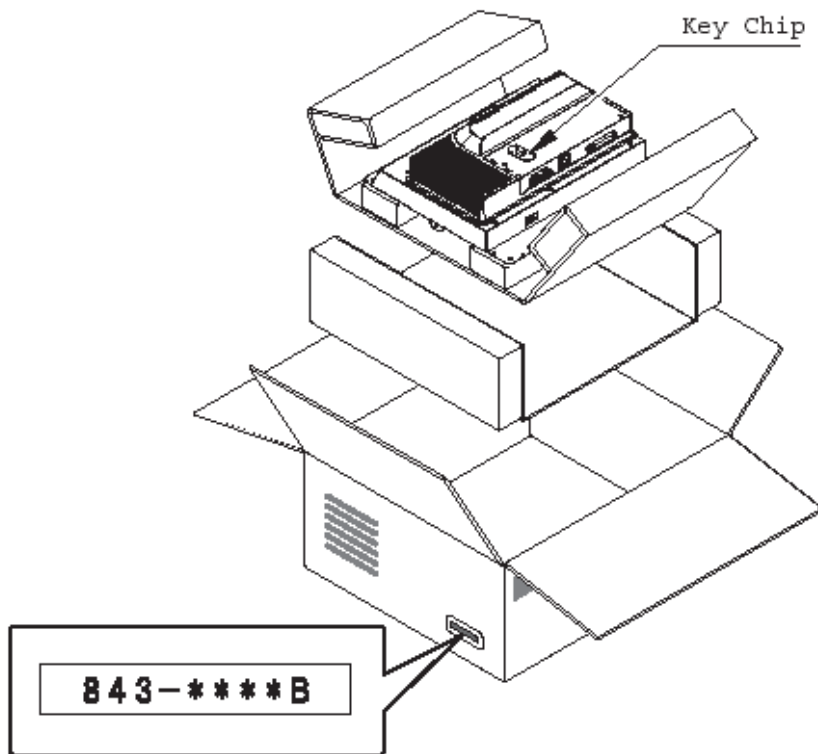

3.7. Assembly Instructions



- Perform the assembly by following the procedure herein stated. Failure to comply with the instructions, for example, inserting the plug into an outlet at a stage not mentioned in this manual can cause an electric shock
- Assembling should be performed as per this manual. Since this is a complex machine, erroneous assembling can cause damage to the machine, or malfunction to occur.
- Do not attempt to complete this work alone, a minimum of 2 people are required.



- Only QUALIFIED SERVICE PERSONNEL should carry out assembly.

When carrying out the assembly work, follow the procedure in the following sequence:

- STEP 1 INSTALLING THE BILLBOARD**
- STEP 2 INSTALLING THE FLOOR**
- STEP 3 CONNECTION TO THE POWER SUPPLY**
- STEP 4 ASSEMBLY CHECK**

Note that the parts contained within the installation kit are required for the assembly work.

The following tools will be required when installing this machine:

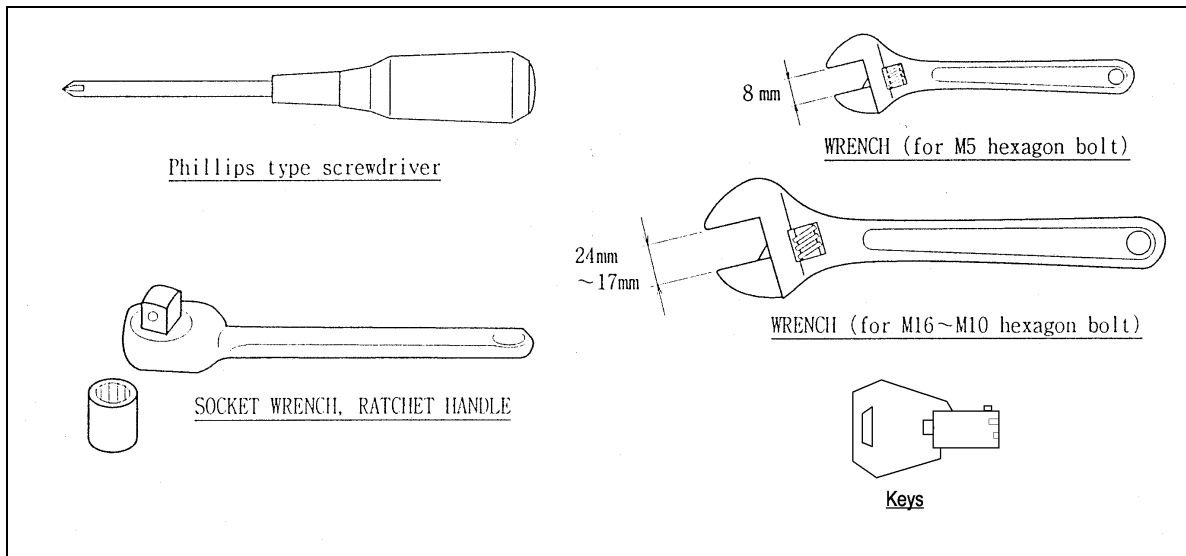

3.7.1. Installing The Billboard



CAUTION



IMPORTANT

- To perform work safely, use a secure and stable step to improve access to the top of the cabinet. Working without using a step may cause accidents.

- Only QUALIFIED SERVICE PERSONNEL should carry out this operation.

1. Insert ASSY BILLBOARD to the top part of the cabinet
2. Secure with the two Tamperproof screws (Part No. 008-T00412-0B, supplied with Accessory kit)

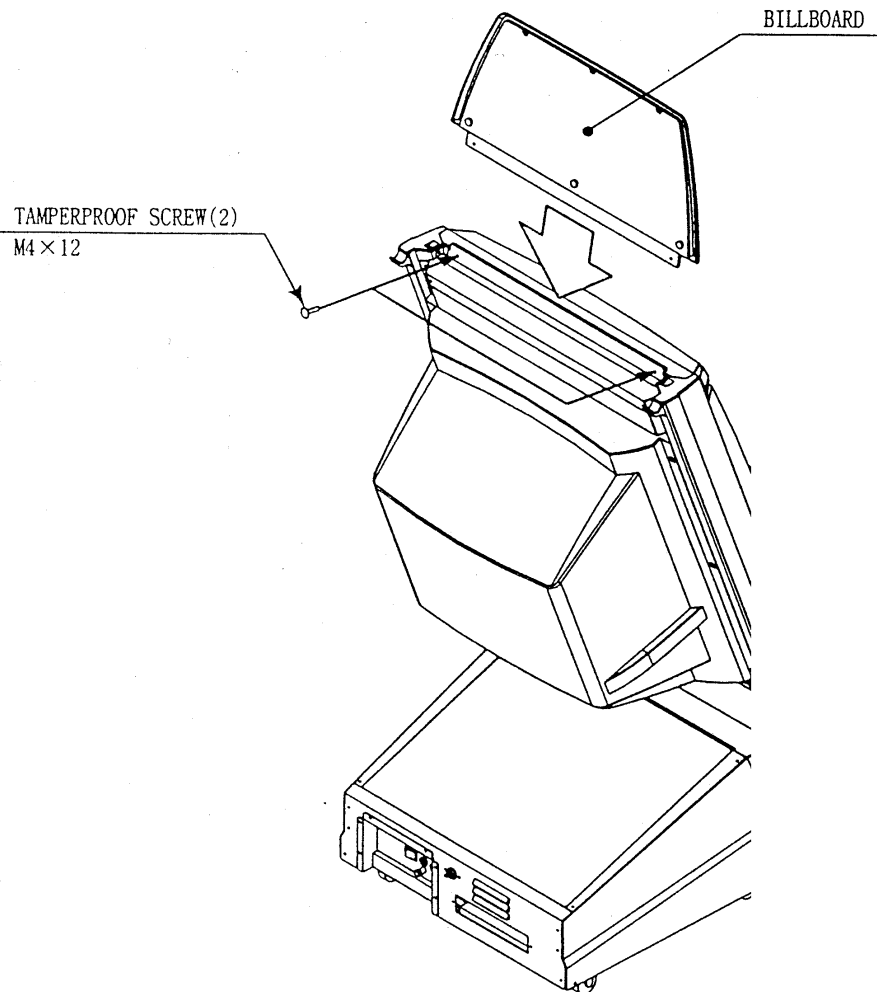

3.7.2. Installing The Floor And Leg Adjustor Adjustment



- Ensure all connections are secure - poor connections can cause electric shock or short circuit.
- Take care not to damage wiring during installation, as this can cause electric shock or short circuit.

- ① Unlock and remove the SERVICE DOOR from the front of the cabinet.

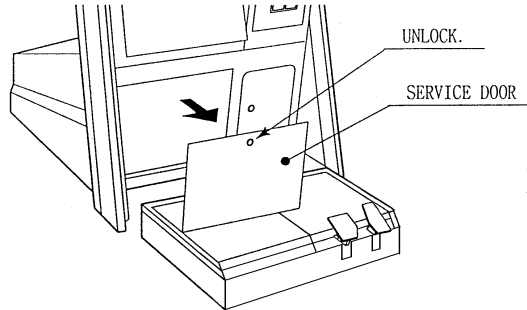

- ② Remove the plastic nut of the Connector at the end of ASSY FLOOR's Flexible Tube.
- ③ Insert the Connector at the end of Flexible Tube into the round hole on the bottom of cabinet from the underside, and secure by fastening the plastic nut. At this time, be careful so as not to damage the wire passing through the Flexible Tube.

- ④ Connect the Connector at the end of the wires passing through the Flexible Tube to the Connector inside the cabinet.

After connecting the Connector inside the cabinet, secure the Connector with Clamps.

- ⑤ Secure the wires with Cord Clamp.
- ⑥ Fit ASSY FLOOR tightly to the cabinet.

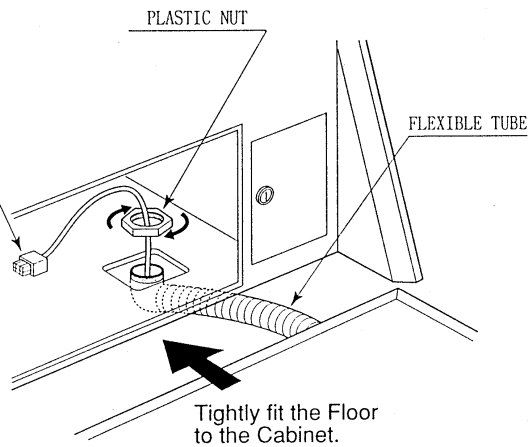

- ⑦ Slightly lower the 2 Adjusters on the cabinet and install JOINT BRACKET L & R by inserting from the rear, and secure to ASSY FLOOR using hexagon bolts as shown.



- Make sure all of the leg adjusters are in contact with the floor. If they are not the machine may move and cause injury. This operation requires 2 people.



IMPORTANT

- Only QUALIFIED SERVICE PERSONNEL should carry out this operation.

- ⑧ After lowering the Adjusters fully downward so that they raise both front castors 7mm from the floor, tighten both Adjuster's lock nuts fully upward.

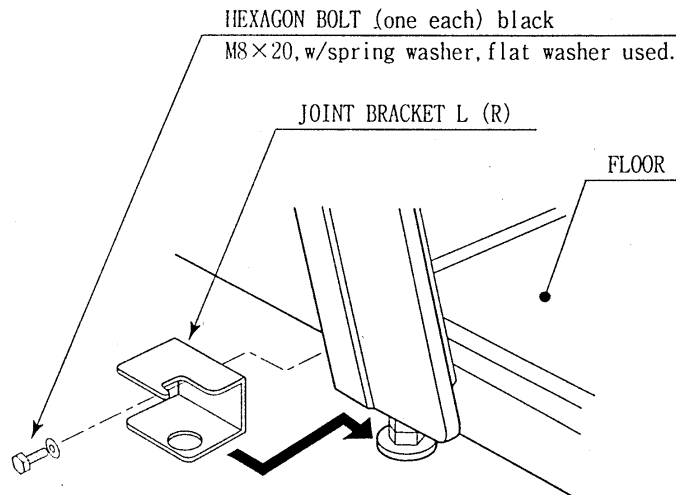

- ⑨ If this product is installed on irregular surfaces, use the two Level Adjusters on the bottom of the FLOOR to ensure the product is level.

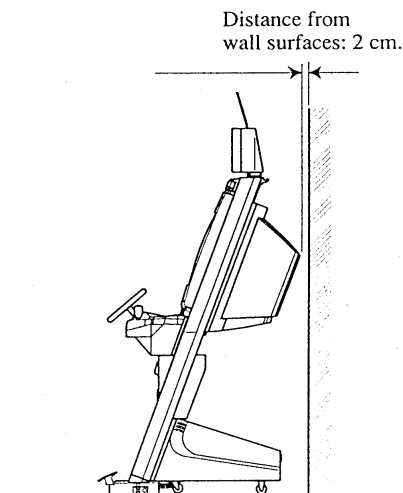

Provide sufficient space so as to allow for ventilation by the Air Vent.

3.7.3. Coin Handling Installation



- Only QUALIFIED SERVICE PERSONNEL should carry out this operation.

When fitting the coin mechanism to the door please refer to the specific manufacturers installation instructions for that coin mechanism. To fit the door to the machine follow the procedure below.

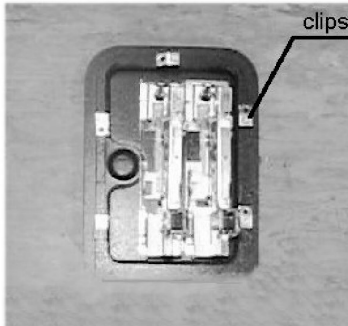

- Loosen all of the bolts on the frame that secure the clips.
- Turn all clips in towards the door.



- Position the door into the aperture in the machine.
- Turn the clips around so that they will hold the door in the machine.
- Tighten all of the bolts.

NOTE: DOUBLE FRAMED MINI DOOR SHOWN. SINGLE FRAMED DOOR SIMILAR FITTMENT.

3.7.3.1. Wiring Connections

COIN MECH	LOOM	INSTALLATION
C220B	LM1006IDC LM1006LAMP-0.1	<ul style="list-style-type: none"> • Attach the lamp holder to the bracket on the coin return button. • Attach one 15-way connector to the C220 coin mech. • Attach the other 15-way connector to Validator A on the credit board. • Attach the 2-way connector to 'LAMP' on the VTS board.
GENERIC MECHANICALS	LM1008 LM1008-LAMP	<ul style="list-style-type: none"> • Fit the two lamp holders behind the coin return buttons. • Attach the blue cable and orange cable to one mech's microswitch switch. • Attach the blue/green cable and orange/green cable to the other mech's microswitch. • Attach the 2-way mate and lok plug to the 2-way mate and lok cap provided. • Attach one 15-way connector to Validator A and the other to Validator B on the credit board
MARS MS111B1 MARS ME115	LM1007 LM1008-LAMP	<ul style="list-style-type: none"> • Fit the lamp holder to the bracket behind the coin return button. • Fit one of the 13-way connectors to the coin mech. • Fit the other 13-way connector to Validator A on the credit board. Note the 13-way connector is keyed and this key must coincide with the key on the credit board.
SECI, C120, SR3	OWN LOOM AND LM1006LAMP-0.1	<ul style="list-style-type: none"> • Attach the lamp holder to the bracket on the coin return button. • Attach the 2- connector to 'LAMP' on the VTS board. • Attach the validator's own loom to position A on the credit board

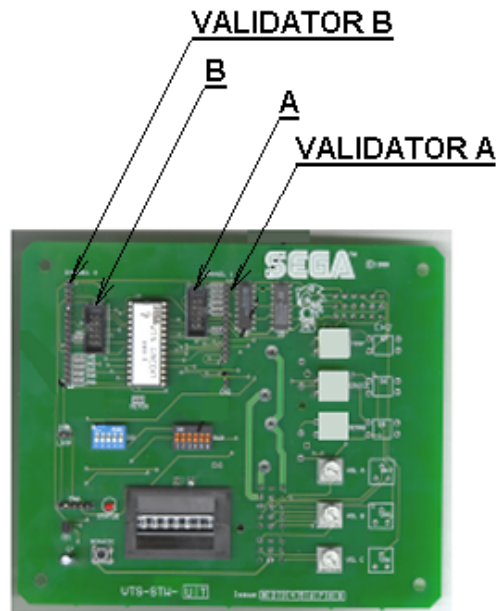

VTS credit board assembly

3.7.4. Connection To The Power Supply



- Be sure that the machine is not connected to the mains supply before attempting this operation

- Only QUALIFIED SERVICE PERSONNEL should carry out this operation.

1. The AC Unit is located on the right hand side of the base unit, when viewing the screen. It houses the IEC inlet, mains switch and fuse.

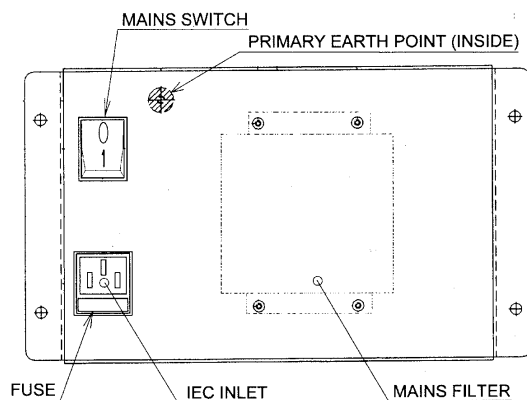

2. Ensure that all of the machine's wires have been connected in accordance with the preceding Sections and that the mains switch is OFF.
3. Check that the operating voltage of the mains supply matches the machine (Section 1.1).
4. Insert the IEC lead into the IEC inlet and the mains plug into a wall socket. If applicable, switch the wall socket ON.
5. Stand clear of the machine and switch the mains switch ON.

3.7.5. Assembly Check

In the Test Mode, ascertain that the assembly has been made correctly and IC BD is satisfactory (see Section 5.3).

In the test mode perform the following test:

3.7.5.1. CRT Test



• Only QUALIFIED SERVICE PERSONNEL should carry out this operation.

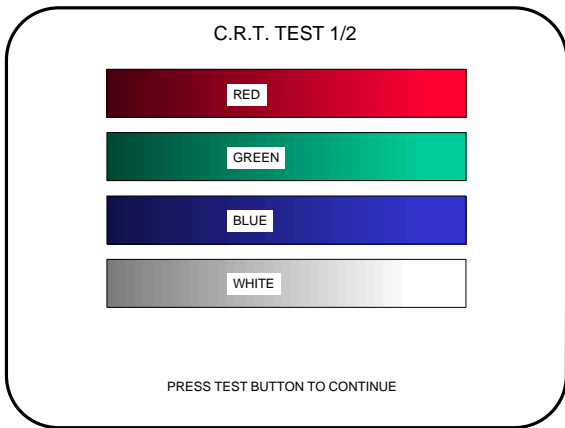

In the TEST mode select CRT test to check the screen is satisfactory.

Although the projector has been set up at the factory before shipment, check to see if the screen needs adjustment.

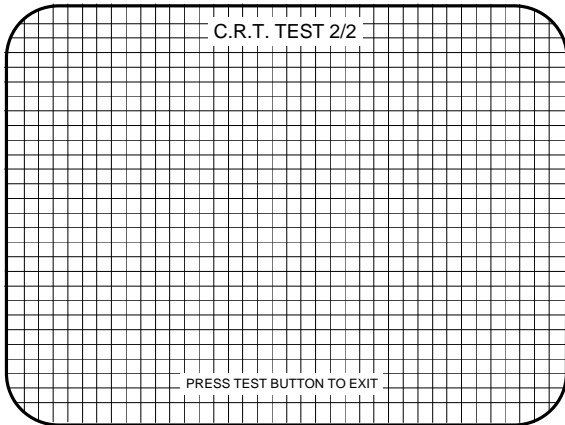

3.7.5.2. Memory Test

Selecting RAM TEST or MEDIA BOARD TEST from the menu screen in System Test mode will cause the machine to automatically perform a test of memory on the game boards. If GOOD is displayed next to the number of each memory segment, the game boards are working properly.

Select SYSTEM INFORMATION to display information on the main game board and the media board. If the information is displayed correctly, this indicates that the game boards are functioning properly.

```
RAM TEST

AUX MEMORY          GOOD

TEST BUTTON TO EXIT
```

```
MEDIA BOARD TEST 1/2

DIMM BOARD(TYPE 3)
VERSION ****
STATUS GOOD
CHECKING 100%

DIMM TEST
DIMM0 - GOOD
DIMM1 - NONE
GD-ROM - GOOD

PRESS TEST BUTTON TO EXIT
```

```
MEDIA BOARD TEST 2/2

NETWORK BOARD
VERSION ****
STATUS GOOD
CHECKING 100%
NETWORK BOARD TEST
RAM CHECK _ GOOD
-- COMPLETED --

PRESS TEST BUTTON TO EXIT
```

```
SYSTEM INFORMATION
MAIN BOARD
REGION ****
BOOT VERSION ****
FIRM VERSION ****
FPGA VERSION ****
SERIAL NO. *****

MEDIA BOARD
DIMM BOARD(TYPE 3) + GDROM
MEMORY SIZE 512MB
FIRM VERSION ****
SERIAL NO. *****

NETWORK BOARD
FIRM VERSION *****

PRESS TEST BUTTON TO EXIT
```

3.7.5.3. Input Test

Select INPUT TEST from the menu screen in either System Test mode or Game Test mode.

JVS TEST	
INPUT TEST	
NODE	1/1
SYSTEM	00
PLAYER 1	1 0000
PLAYER 2	2 0000
COIN 1	1 0000
COIN 2	2 0000
ANALOG	1 0000
ANALOG	2 0000
ANALOG	3 0000
ANALOG	4 0000
ANALOG	5 0000
ANALOG	6 0000
ANALOG	7 0000
ANALOG	8 0000

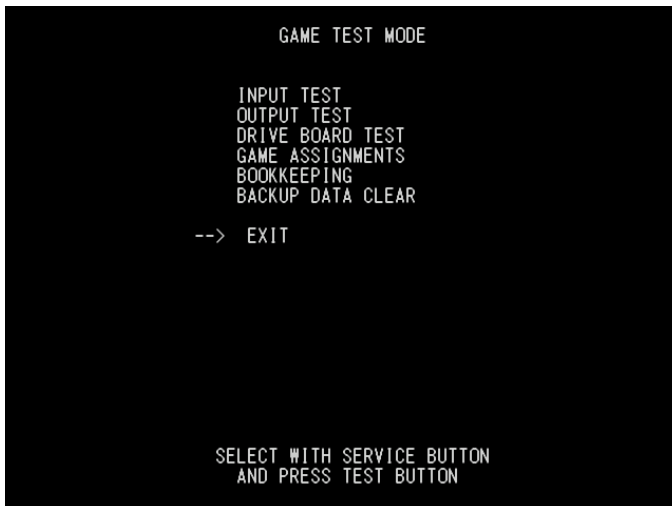

Test the STEERING, GAS (ACCEL) and BRAKE controls to ensure that they are functioning properly and that the parameters change smoothly as each input device is operated.

Display N, UP and DOWN using the GEAR POSITION. N displays that there is no control input. Verify that both UP and DOWN display in sync with the position of the shift knob.

Press the START, CHANGE VIEW, SERVICE and TEST Buttons. If functioning correctly, each indicator will switch from OFF to ON.

Press the SERVICE and TEST Buttons simultaneously to return to the Game Test Menu screen.

3.7.5.4. Output Test

Select OUTPUT TEST to display the following screen and check the status of each lamp. This test should be used periodically to check that the lamps are functioning correctly.

On this screen the cursor will switch automatically between items, lighting up the respective lamps.

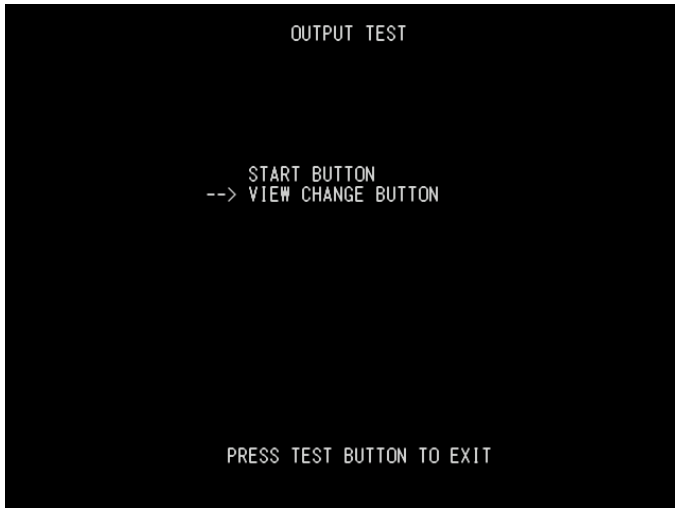

- START BUTTON : Lights up the START button.
- VIEW CHANGE BUTTON: Lights up the View Change button.

Press the TEST Button to return to the Game Test Menu screen.

3.7.5.5. Sound Test

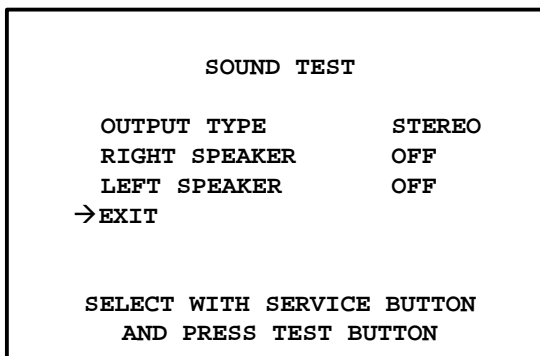

In the system test mode, selecting SOUND TEST causes the screen (on which sound related BD and wiring connections are tested) to be displayed. Check if the sound is satisfactorily emitted from each speaker and the sound volume is appropriate.

3.8. Moving The Machine



- When moving the machine, be sure to remove the plug from the power supply. Moving the machine with the plug inserted can cause the power cord to be damaged, resulting in a fire or electric shock.
- When moving the machine, retract the leg adjusters fully and ensure the casters make contact with the floor. During movement pay careful attention so that the casters or leg adjusters do not damage any other cabling laid on the floor. Such damage could result in a fire or electric shock.
- Do not push the upper part of the cabinet. Failure to observe this can cause the cabinet to fall forwards and result in accidents.



- When transporting the machine, be sure to hold the catch portion on the rear of the cabinet with the castors making contact with the surface as shown below. Inclining the machine by holding portions other than the catch or moving the cabinet without retracting the adjusters can damage the cabinet and/or the floor surface.
- Do not push the Billboard. Failure to observe this may damage the installation portions and may cause unexpected accidents.



- Only QUALIFIED SERVICE PERSONNEL should carry out this operation.

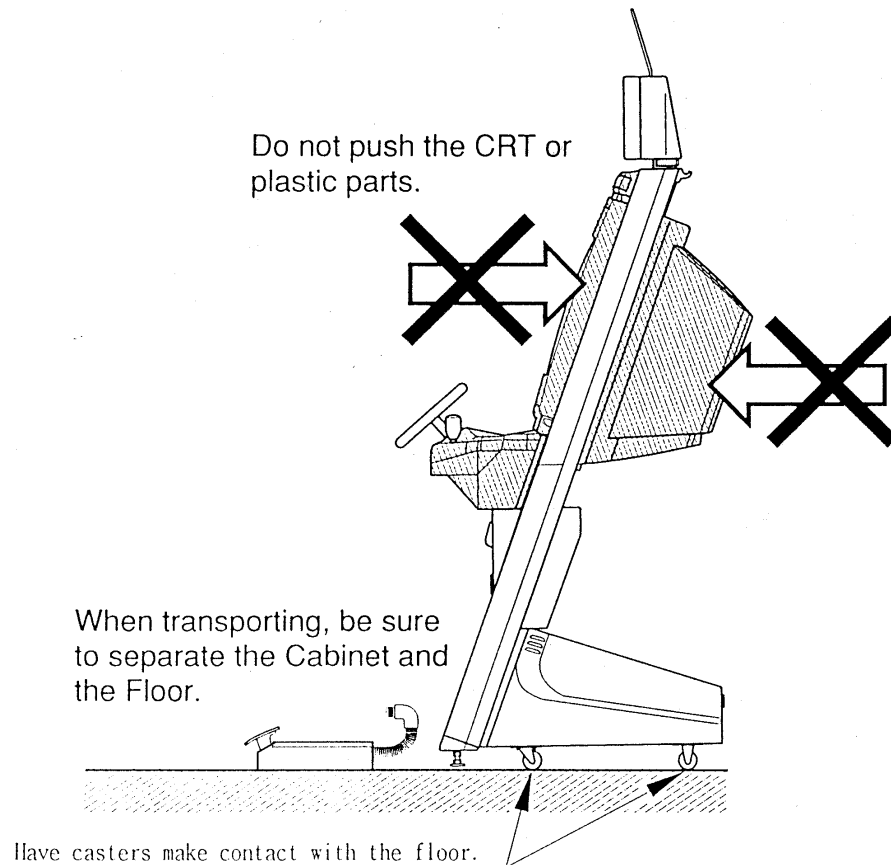

3.9. Control Panel (Handle Mecha.) - 'HAPP' Type



- Before starting work, ensure that the cabinet is isolated from the mains by switching off and removing the IEC mains lead from the wall outlet.
- Be careful not to damage wiring. Damaged wiring can cause electric shock and short circuits.



- When closing the Control Panel be very careful to avoid trapping fingers or hands.



- Only QUALIFIED SERVICE PERSONNEL should carry out this procedure.

3.9.1. Replacing Volume

If the steering operability becomes poor, and adjusting the VOLUME SETTING in the TEST MODE is ineffective, the cause may be the failure of the Volume Gear to mesh and/or the Volume Potentiometer malfunctioning.

When the Steering Wheel is rotated fully left or right, if the Volume shaft is rotating within the movable range, the Volume is not feared to be damaged. Use the procedure described herein to position the steering VR such that the correct centre value (refer to Section 5.4) is displayed when the Steering Wheel is at rest.

1. Power OFF the machine and remove the IEC lead from the wall outlet.
2. Remove the three tamperproof screws and open the Control Panel.

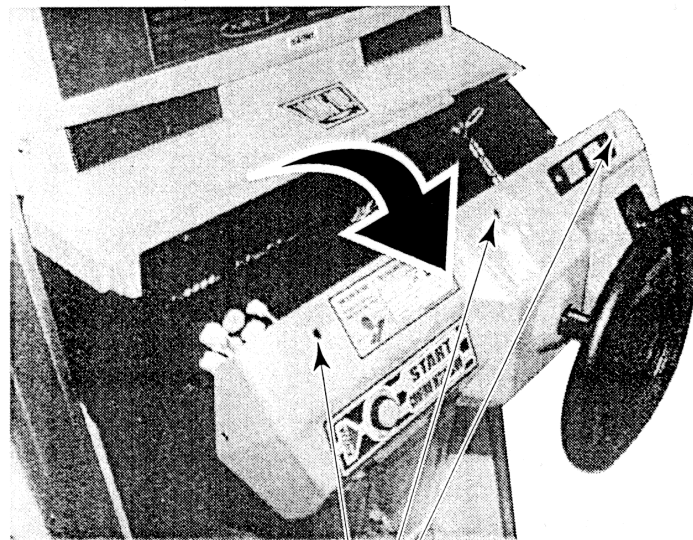

TAMPERPROOF SCREW (3)
M8×20, flat washer used. (black)

1. Loosen the two screws and adjust the gear mesh by moving the VR Bracket.
2. Adjust to an appropriate setting by securing the steering wheel in the straight ahead position.
3. After adjustment, check the volume setting as described in Section 5.4. If necessary, repeat steps 3 & 4 until the volume value is within allowable limits ($\pm 3H$)

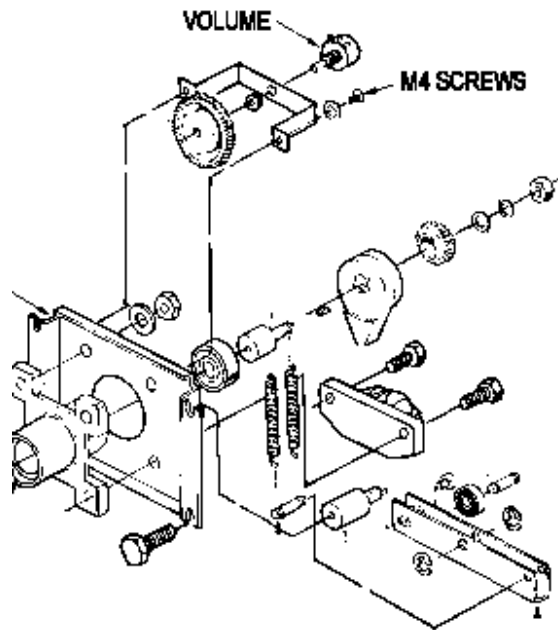

HOW TO REPLACE

1. Disconnect the Volume Connector.
2. Take out the two screws and remove the Volume together with the VR Bracket.
3. After replacing the Volume, engage the gears at the angle shown and fix the VR Bracket.

Close the Control Panel and replace the three tamperproof screws before turning power ON and setting the Volume value in the TEST MODE.

3.9.2. Greasing – SEGA and HAPP types



- Use only synthetic grease (grease or spray) as plastic parts are used. Do not use mineral based greases.
- Applying grease to parts other than those specified can cause malfunctioning or quality deterioration of parts.

Apply grease to the gear mesh and cam portions once every three months. Use a proprietary synthetic lubricant.

HAPP type

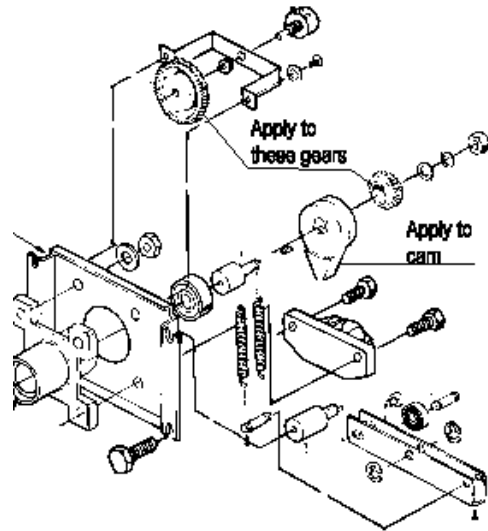

3.9.3. Replacement Of Spring

HAPP type

In case of spring damage or wear, open the Control Panel and replace the spring.

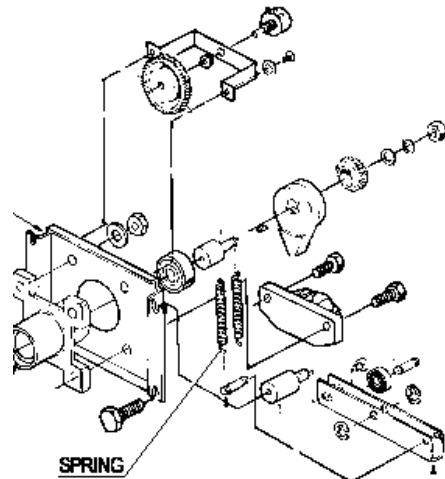

3.10. Shift Lever

If the SHIFT LEVER SWITCH is not showing an input in the TEST MODE, replace the switch. Remove the Shift Lever Unit and apply grease to the mechanism's sliding portion once every three months.



IMPORTANT

- When performing work, be sure to turn power off. Working with power on can cause an electric shock or short circuit.
- Use care to ensure the wiring is not damaged. Damaged wiring can cause electric shock or short circuit.

- This operation should only be carried out by QUALIFIED SERVICE PERSONNEL

3.10.1. Removing Shift Lever

1. Turn the Power Switch OFF.
2. Remove the four tamperproof screws and lift out the Shift Lever Unit far enough to access the connector.
3. Disconnect, and withdraw the Unit completely.
4. Reinstall in reverse order, ensuring the label marked 'THROW' is at top.

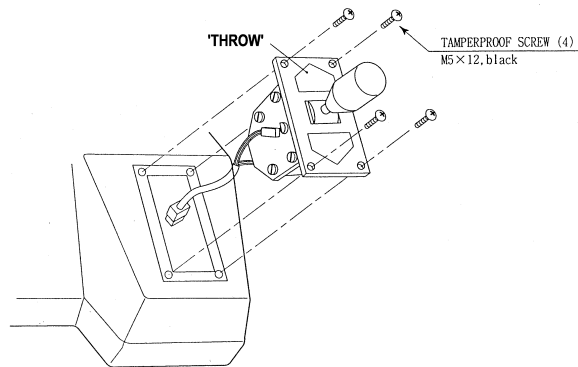

3.10.2. Switch Replacement

1. Disconnect the switch to be replaced.
2. Remove the two Tapping Screws (M3 x 16) to replace the microswitch.

3.10.3. Greasing

Apply grease to the gear mesh portions once every three months. Use a proprietary synthetic lubricant.

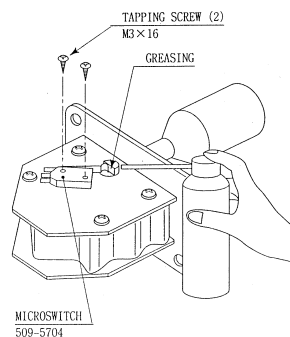

3.11. Accelerator And Brake



- Before performing work, be sure to turn power off. Working with power on can cause an electric shock or short circuit.
- Use care to ensure the wiring is not damaged. Damaged wiring can cause electric shock or short circuit.
- Touching parts of the machine other than those specified here can cause electric shock or short circuit.



- This procedure to be carried out only by QUALIFIED SERVICE PERSONNEL.

If the operation of the Accelerator and Brake pedals is unsatisfactory and not remedied by adjustment of the VOLUME SETTING in the TEST MODE, the cause may be mesh failure of the Volume Gear or a faulty Volume potentiometer. Follow the procedure below to adjust the Volume Gear mesh or replace the Volume potentiometer.

When the pedals are depressed fully, if the Volume shaft is rotating within the movable range, the Volume is not feared to be damaged. Use the procedure described herein to position the VR such that the correct values (refer to Section 5.4.) are displayed at both extremes of pedal travel.

3.11.1. Removing The Accelerator And Brake

1. Turn the power switch OFF and remove the IEC cable.
2. Take out the seven truss screws and remove the Floor Lid.

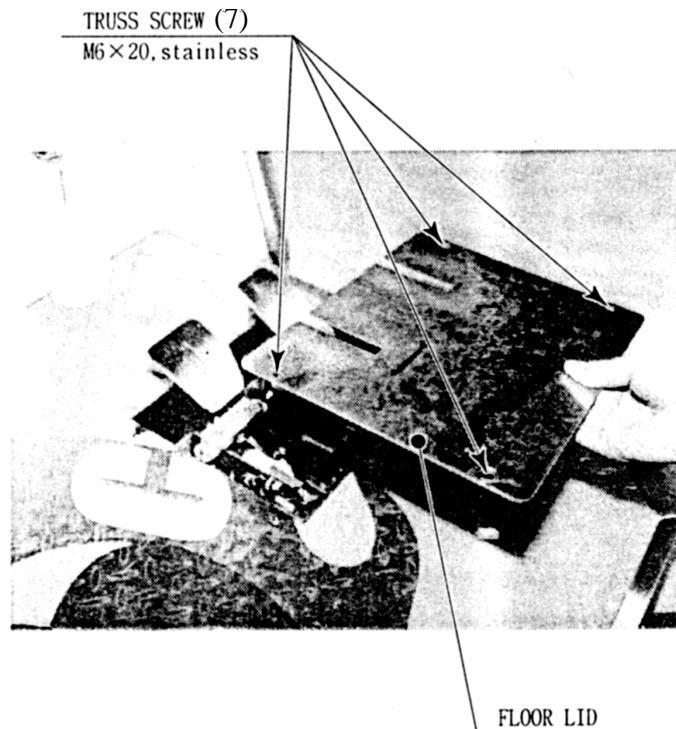

3. Take out the six hexagon nuts to remove the Accelerator (or Brake) Unit.
4. Disconnect the Connector and remove the Accelerator (or Brake) Unit.

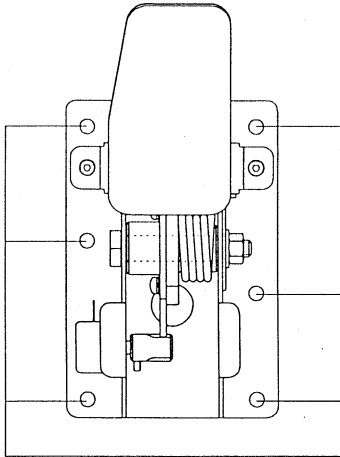

HEXAGON NUT (6)
M6, SPRING WASHER USED

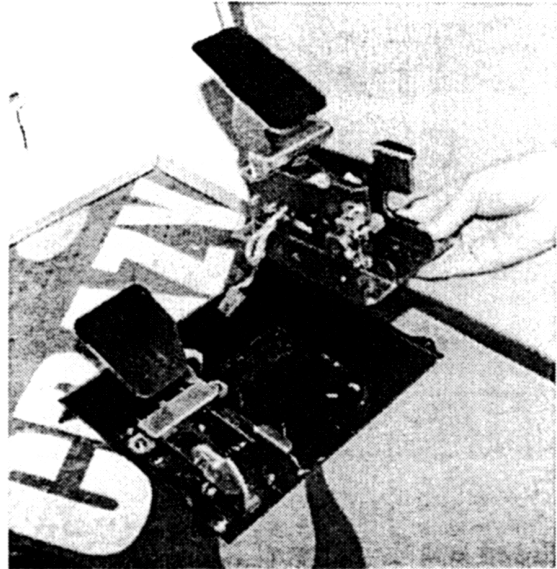

3.11.2. Adjusting Or Replacing The Volume

ADJUSTMENT:

1. Loosen the Hex Bolt shown, and adjust the angle for optimum gear mesh.
2. Check the setting in Section 5.4.

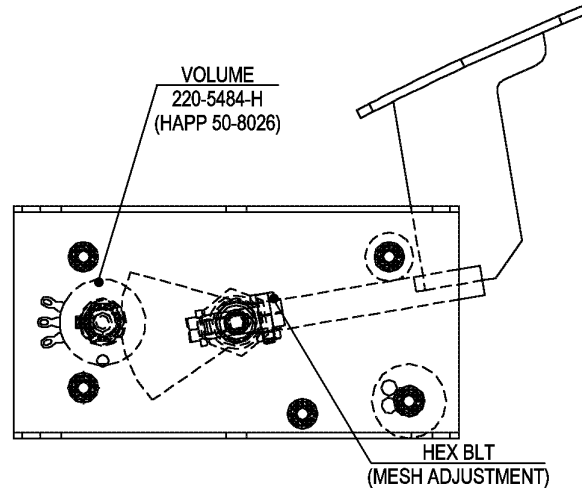

REPLACEMENT:

1. The Volume is panel mounted: remove by undoing the nut and withdrawing the shaft through the panel hole.
2. After replacing the Volume, engage the gears at the angle shown, and replace the nut.
3. Install the Accelerator (or Brake) Unit and connect the connector.
4. Re-install in reverse order and replace the Floor Lid and IEC Cable before turning power ON.
5. Check the setting in Section 5.4.

3.11.3.Greasing



WARNING



IMPORTANT

- When performing work, be sure to turn power off. Working with power on can cause an electric shock or short circuit.
- Use only synthetic grease (grease or spray) as plastic parts are used. Do not use mineral based greases.
- Applying grease to parts other than those specified can cause malfunctioning or quality deterioration of parts.

Apply grease to the gear mesh portion and pedal shaft once every three months. Use a proprietary synthetic lubricant.

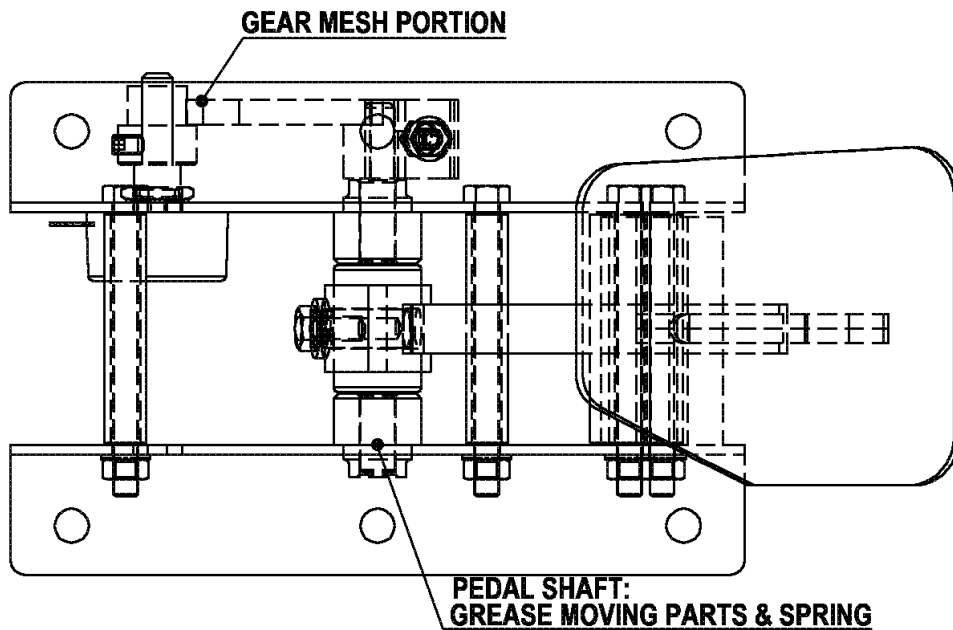

3.12. Replacement Of Fluorescent Lamps



- Never touch places other than those specified. Touching places other than those specified can cause electric shock and short circuit. Disconnect the machine from the supply before attempting the replacement of any lamp.
- When performing work, be sure to turn power off. Working with power on can cause an electric shock or short circuit.
- Hot fluorescent lamps can cause burns. Be very careful when replacing them.
- Use a secure step to improve access to the upper parts of the cabinet.

- Only QUALIFIED SERVICE PERSONNEL should replace lamps.

3.12.1. Front Fluorescent:

1. Turn power OFF at the Main Switch and remove the IEC lead.
2. Open the Control Panel (see Section 3.9).
3. Remove the two truss screws and open the entry panel.

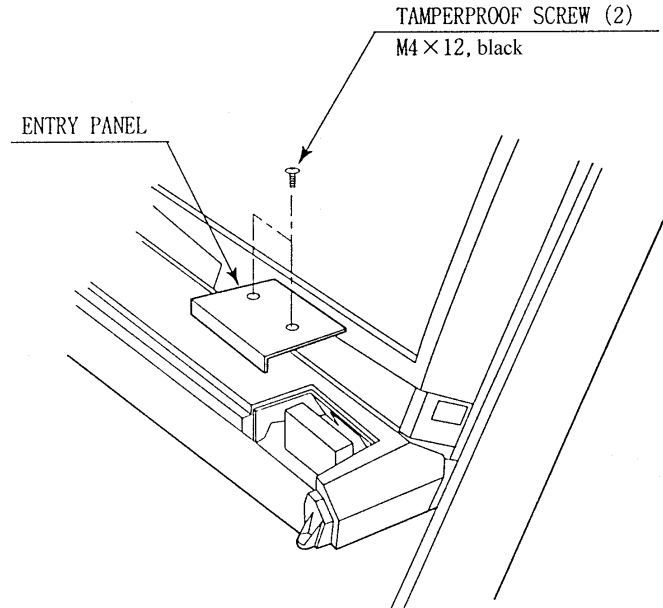

4. By using a flat bladed screwdriver, remove the four screw caps from the front panel.

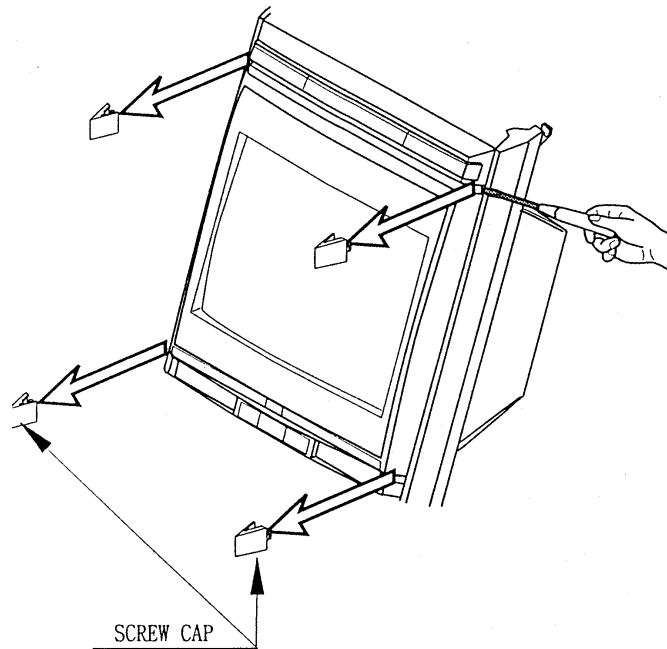

5. Take out the four tamperproof screws and the two lower screws, and carefully take off the Front Panel.
6. Remove the Billboard assembly as detailed in Section 3.7.1.
7. Remove the four screws and the Earth Link to allow the Billboard Holder to be removed.
8. To remove the Fluorescent lamp disconnecting the two end caps and withdraw the Lamp upwards through the two mounting clips.
9. After replacing the lamp, reassemble in reverse order, being sure to replace the Earth Link between the Billboard Holder and frame.

FLUORESCENT LAMP 40W:
390-5695-40-DUK

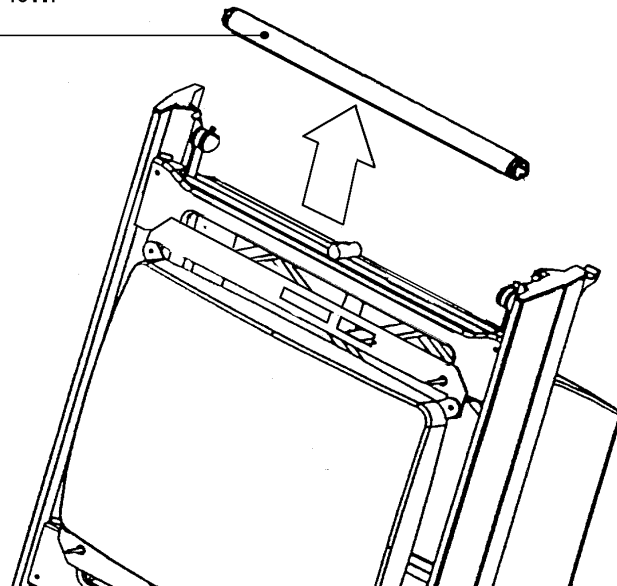

3.13. Game Board



- When performing work, be sure to turn power off. Working with power on can cause an electric shock or short circuit.
- Be careful not to damage wiring. Damaged wiring can cause an electric shock or short circuit.
- The voltage/ampere ratings for the Game Board are 3.3V 12A, 5.0V 10A and 12V 2A. To avoid risk of fire, never use any board with supply requirements exceeding the above.
- When replacing the Game Board with one not of JAMMA standard, be sure to use only the harness supplied by the manufacturer of the Game Board. Using other harnesses constitutes a fire risk.



- Only QUALIFIED SERVICE PERSONNEL should carry out this operation.

3.13.1. Taking Out The Game Board

To take out the Game Board (Chihiro), remove together with the wooden base on which the Game Board is mounted. If the Game Board is faulty, return to SEGA within the original packaging provided. There are no user-serviceable parts inside.

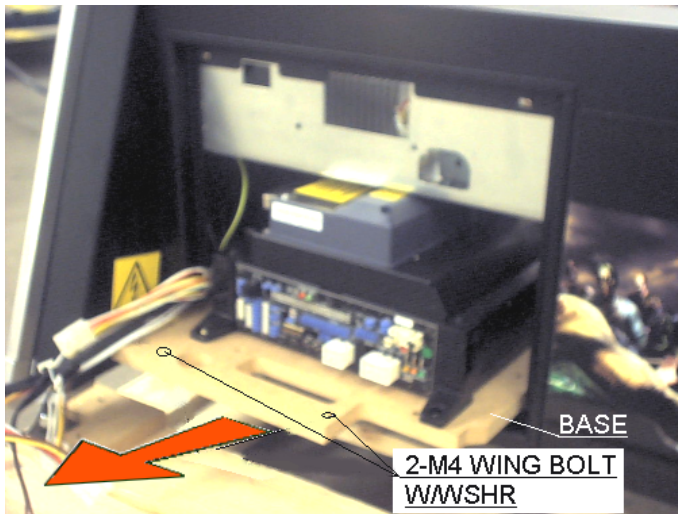

1. Turn off the power.
2. Unlock and remove the Service Door.
3. Disconnect all harnesses linking the Game Board assembly to the cabinet.
4. Remove the two M4 wing bolts and carefully withdraw the assembly upwards and out through the service opening (see following page).

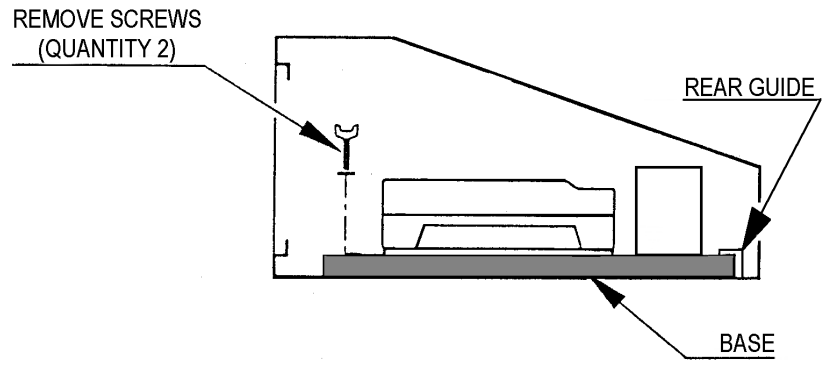

PULL TO
WITHDRAW
BASE FROM
REAR GUIDE

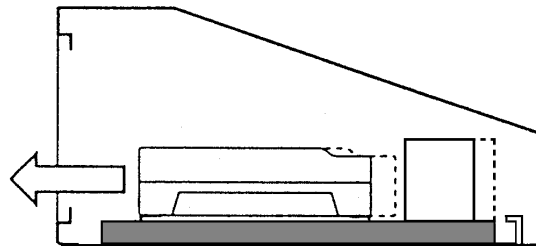

LIFT FRONT
OF BASE

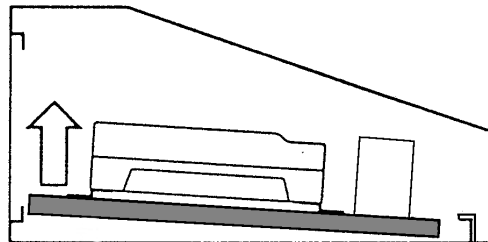

REMOVE BASE

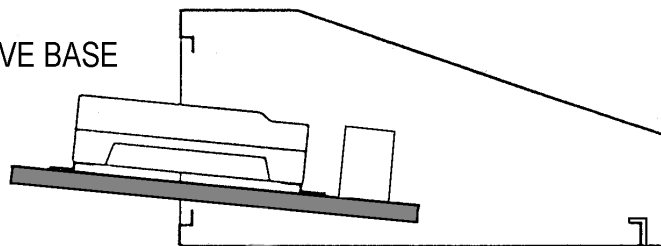

4. Take out the four screws and remove the Shield Case.

3.13.2. Removing The GD-ROM Drive

Take out the ASSY MAIN BD from the cabinet and remove the GD-ROM Drive from the ASSY MAIN BD as follows:

1. Following the above procedure (steps 1 to 5), take out the ASSY MAIN BD.
2. Remove the GD cable connector and the power cord connector from the GD-ROM Drive.

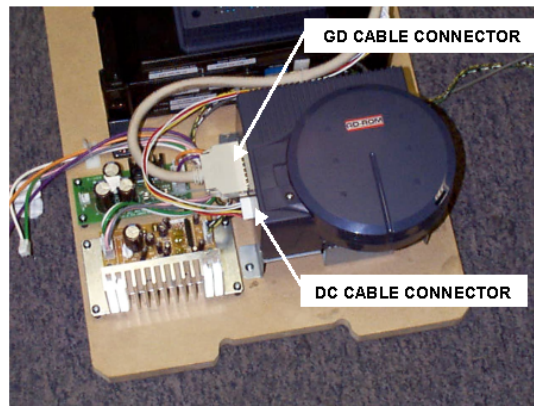

2. To remove the GD-ROM Drive, undo the 3 screws shown.
3. Reassemble in reverse order.

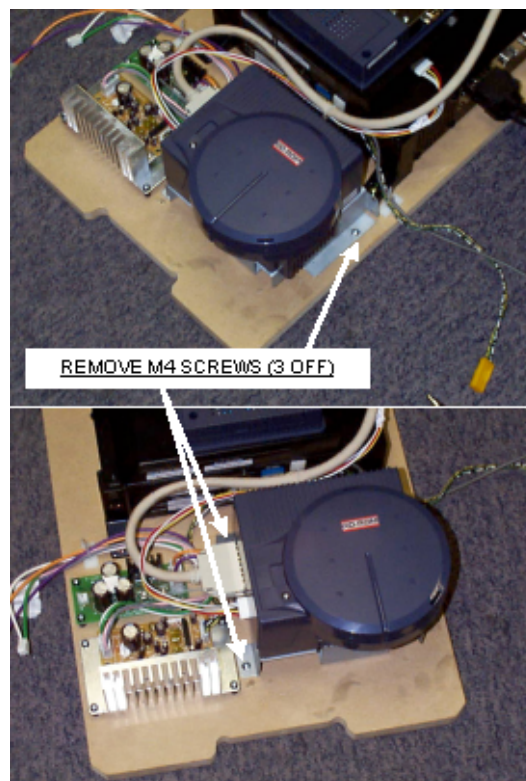

3.13.3.Composition of the Game Board

Once the Chihiro Board has the Key Chip inserted, it is this product's specialized Game Board.

ASSY CASE BOX ORT EXP 843-0005D-02

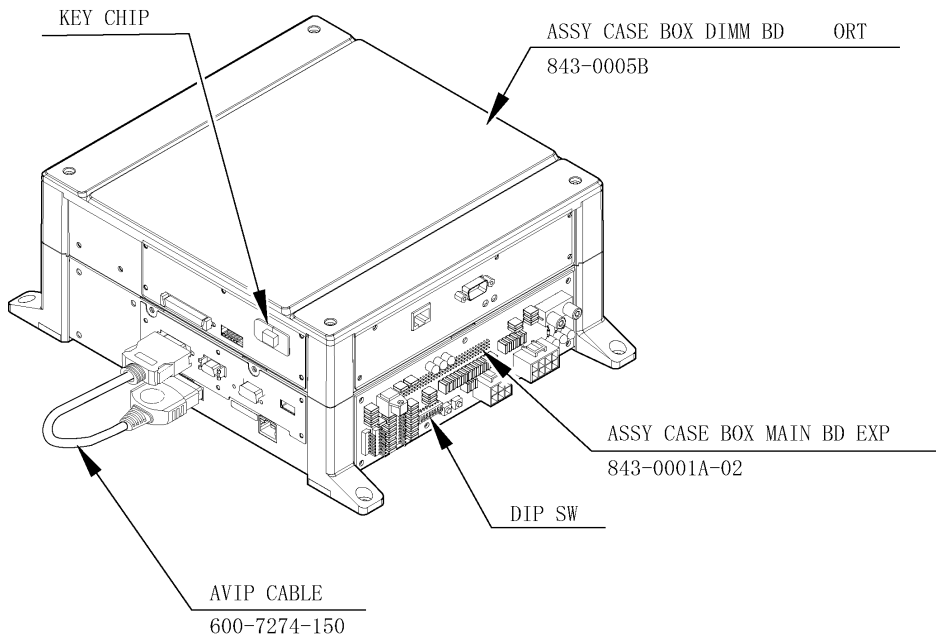

DIP SW SETTING

Use this product with the DIP SW settings shown in the figure below.

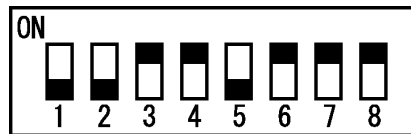

3.13.3.1. Replacing The Main Board Battery



- To prevent overheating, explosion, or fire:
 - Do not recharge, disassemble, heat, incinerate, or short the battery.
 - Do not allow the battery to come into direct contact with metallic objects or other batteries.
 - To preserve or to dispose of the battery, wrap it in tape or other insulating material.
- Follow local regulations when disposing of the battery. Improper disposal can damage the environment.



- To avoid risk of malfunction and damage:
 - Make sure the positive and negative ends are aligned correctly.
 - Use only batteries approved for use with this unit.



- If an error appears indicating that the battery power is very low within the first year of use, it is usually an indication of a problem or abnormality with something other than the battery. Be sure to inspect the board that the battery is connected to.

There is a Media Board Button Battery underneath the Media Board.

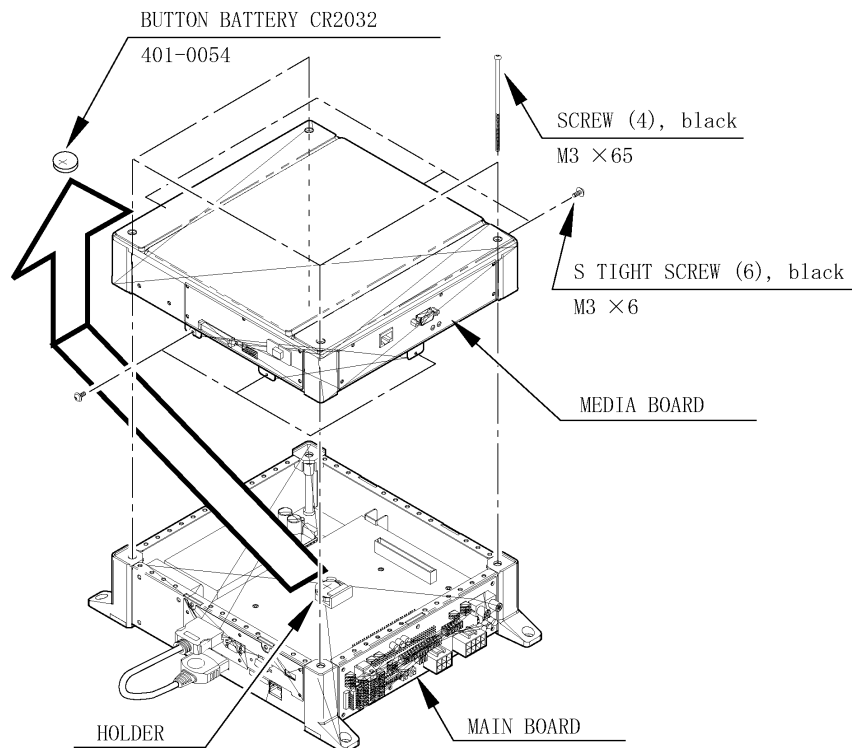

- Carefully remove the battery from its holder.
- Insert a new battery into the holder with the "+" terminal facing up.

3.13.3.2. Replacing The Media Board Battery Pack

Prohibitions and Cautions to Handle the Battery Pack

- Be careful when handling the battery pack.
- We bear no responsibility for problems caused by handling clearly contrary to the content of this manual.



- Do not disassemble the battery pack and the batteries.
- If you should fail to observe this instruction, the internal wires and/or protective devices may be damaged; as a result the safety system may not function when discharging and recharging, eventually causing an overheating, fire and explosion. If you should disassemble the batteries, the generated gases may harm your throat and the negative plate may overheat and make a fire.
- Do not make an external short circuit of the battery pack and the batteries. If you should fail to observe this instruction, the batteries may overheat, make a fire, and explode.
- Do not fire the battery pack and the batteries. If you should fail to observe this instruction, the batteries may make a fire and explode.
- Do not leave the battery pack and the batteries nearby the heat source (fire or heater) or under the intense direct sunlight and flaming sun. If you should fail to observe this instruction, the batteries may reduce the service life and in the worst case may overheat, make a fire, and explode.
- Do not leave the battery pack and the batteries in water or seawater. Also do not apply water or seawater onto the battery pack and the batteries. If you should fail to observe this instruction, the internal wires and/or protective devices may be damaged; as a result the safety system may not function when discharging and recharging, eventually causing an overheating, fire and explosion. Also water may be electrolyzed into oxygen and hydrogen, and eventually the battery's sealed section may be corroded and the internal liquid may leak.
- Do not solder on the battery pack's terminals. If you should fail to observe this instruction, the armor may be heated and melted or the internal wires may be damaged, eventually causing an overheating, fire and explosion. Also, when the battery's temperature reaches to 100°C or more, the battery may leak its internal liquid due to destruction of its plastic parts (gasket, separator, etc.), or may overheat, make a fire, or explode due to internal short-circuit.
- Do not insert or connect the battery in a reversal polarity. If you should fail to observe this instruction, the battery may be externally short-circuited and eventually overheat, make a fire, or explode, depending on the device you connect with.



- Do not tightly seal the battery pack when installing it onto an external device.
- Flammable gas is generated from the battery when its safety mechanism has functioned. If you should fail to observe the above-described instruction, sparks from motors, switches, etc. may cause the gas to fire. Therefore, install the battery pack so that the gas can be quickly released from the external device.
- Do not use the battery pack for the device/usage other than this game system. If you should fail to observe this instruction, the battery and/or the device may be damaged due to non-applicable specifications.
- Do not strike a nail in, hammer, step on, or apply any other forms of pressures and shocks on, the battery.
If you should fail to observe this instruction, the battery may be deformed. As a result, the battery may burst at its sealed sections to leak the internal liquid, or may be short-circuited internally to overheat, make a fire, and explode.
- Do not use a battery charger because any battery charger is not usable for this battery pack.
If you should fail to observe this instruction, the gas may be suddenly generated in the battery and eventually the battery may overheat, make a fire or explode.
- If the battery in use or in keeping shows an abnormal indication (deformation, change of color, bursting of the armor cover, etc.), immediately stop using or keeping it. If it leaks and smells abnormally, immediately keep it away from fire and put it in a safety box.
- If the liquid leaks from the battery and gets in your eyes, do not rub your eyes but immediately wash them with clean water (city water etc.); and consult a medical doctor for a treatment. If you should fail to observe this instruction, the liquid may harm your eyes.
- The battery pack armor (a polyvinyl chloride tube) may be damaged or deformed by external force or heat. When transporting the battery pack or replacing it with a new one, therefore, be careful not to drop or excessively shock it. Do not continue to use any damaged or deformed battery pack. If you should fail to observe this instruction, the battery may overheat, make a fire, or explode.
- The battery pack contains a printed circuit board (PCB) for protective circuitry. It may be destroyed by the static electricity. When handling or servicing the battery pack, therefore, take preventive measures against the static electricity.
- If your battery pack has shown destruction of a protective circuitry PCB, do not continue to use it. If you should fail to observe this instruction, the battery may overheat, make a fire, or explode.
- When wiring the battery pack to a device, be careful not to apply excessive force onto the connectors and lead wires. The battery may overheat, make a fire, or explode if the connectors and lead wires are damaged.
- When discarding the battery pack at a disposal specialist, be sure to cover the terminals with tape or some other covering and avoid damage when packing.



- Do not do away with the used battery packs carelessly because they may contaminate the environment. Be sure to dispose of the used battery packs in accordance with the laws/regulations of your country.

If the GD-ROM read time becomes excessively long, it is likely that the Media Board battery pack life is running low.

No battery pack charger is available.

Follow the procedure to replace the battery pack:

1. Remove 4 screws from the upper face of the board.
2. Remove the top cover.
3. Remove 1 tapping screw and remove the cover battery holder.
4. Disconnect the connector at the end of the wire coming out of the battery pack. Remove by pressing the projection on the connector and pulling.
5. Securely connect the new battery pack.
6. Attach the cover battery holder and top cover.

Submit the used battery packs to an industrial waste disposal plant. Thus they must be disposed according to the local laws and the regulations in your country.

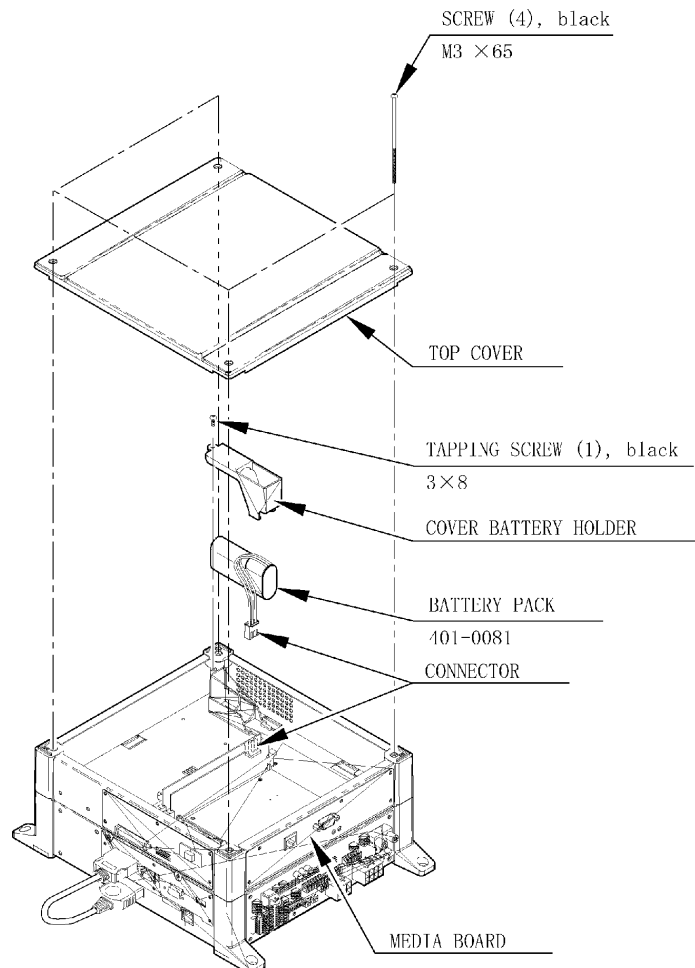

3.14. Troubleshooting



- Only QUALIFIED SERVICE PERSONNEL should carry out these procedures.

If a problem occurs, first check the wiring connections.

PROBLEMS	CAUSE	COUNTERMEASURES
When the main switch is turned ON, the machine is not activated	The power is not ON.	Firmly insert the plug into the outlet.
	Incorrect power source/voltage.	Make sure that the power supply/voltage are correct.
	AC Unit CIRCUIT PROTECTION DEVICE (ie; fuse) was activated due to an instantaneous overcurrent.	First, remove the cause of overcurrent and reinstate the circuit protection device to its original status. Then identify the cause of the fault on the item which caused the overcurrent & fix.
The colour image on the screen is incorrect.	Incorrect monitor adjustment.	Make appropriate adjustments. Refer to the Monitor Service Manual supplied with this product.
The on-screen image of the monitor sways and/or shrinks.	The power source and voltage are not correct.	Make sure that the power supply and voltage are correct.
Sound is not emitted.	Sound volume adjustment is not correct.	Adjust the volume setting - refer to Section 5.3
	Malfunctioning BD and Amp.	Perform Sound Test to check it. Refer to the Service Manual supplied with the Game Board.
	Connector connection is incorrect.	Check connector connection from Base to Speaker.
The fluorescent lamp(s) does not light up.	Fluorescent lamp(s) needs replacement.	Replace the fluorescent lamp(s). Refer to Section 3.12
	The connector is disconnected.	Check connections - refer to Section 3.12.
Steering Wheel does not operate satisfactorily .	Steering Wheel deviation.	Adjust Volume value in the TEST MODE.
	Steering Wheel Volume malfunctioning.	Replace the Volume (see Section 3.9).
	ADJUST GEAR's engagement in not correct.	Adjust the engagement of ADJUST GEAR (see Section 3.9).
SHIFT LEVER doesn't operate satisfactorily.	Switch malfunctioning.	Replace the switch (see Section 3.10).
Operation of Accel & Brake Pedals is not satisfactory.	VR position deviated.	Adjust the VR value in the TEST MODE.
	VR malfunctioning.	Replace the VR (see Section 3.11).
	ADJUST GEAR's engagement is not correct.	Adjust the adjustment of ADJUST GEAR (see Section 3.11).

3.15. Fuses



- Never touch places other than those specified. Touching places other than those specified can cause electric shock and short circuit. Disconnect the machine from the supply before attempting the replacement of any fuse.
-
- Only QUALIFIED SERVICE PERSONNEL should replace FUSES.
 - Only replace fuses with ones of the same value and type.

There are a number of fuses used on this machine to protect the user and the machine from damage. Only replace the fuse once you have removed the cause of its failure. Detailed below is a list of the fuses used, their location and if relevant PCB reference:

PART NUMBER	LOCATION	TYPE & DETAILS	QTY
514-5078-3150	STEREO AMP REF. F1, F2	5x20mm CERAMIC SB 3.15A	2
514-5078-4000	SWITCH REG REF. F1	5x20mm CERAMIC SB 4A	1
514-5078-5000	IEC INLET REF. F1	5x20mm CERAMIC SB 5A	1
838-11856CE-02	CONN. BD. REF. F1	5x20mm CERAMIC SB 6.3A	1

There are also fuses located on the Monitor PCB. Refer to the relevant Monitor manual supplied to reference these fuses.

3.16. PERIODIC CHECK AND INSPECTION

The items listed below require periodic check and maintenance to retain the performance of the machine and ensure safe operation:



- Be sure to check annually to see if the power cords are damaged, the plug is securely inserted and that there is no dust in the interior of the machine or between the socket and the power cord. Using the product in an unclean condition may cause a fire or electric shock.

DESCRIPTION	WHAT TO CHECK	INTERVAL
CABINET	Check Adjusters' contact with surface	Daily
MONITOR	Clean CRT face - (Do Not use water jet)	Weekly
	Check settings	Monthly
GAME BD	Setting check	Monthly
CONTROL PANEL	Input test	Monthly
Speaker, sound	Sound test, check volume adjustment	Monthly
COIN SELECTOR	Coin insertion test	Monthly
	Cleaning	Tri-Monthly
POWER SUPPLY CORD	Check condition	Annually
INTERIOR	Clean (Do Not use water jet)	Annually
CABINET SURFACE	Clean (Do Not use water jet)	As required

3.17. Cleaning The Cabinet Surfaces

When the cabinet surfaces are badly soiled, remove stains with a soft cloth dipped in water or chemical detergent (diluted with water) and squeezed dry - **DO NOT USE A WATER JET**. To avoid damaging surface finish, do not use such solvents as thinner, benzene, etc. (other than ethyl alcohol), abrasives or bleaching agents.

4. CONTENTS OF GAME

The following information assumes that the product is functioning satisfactorily. Should there be any discrepancies, a fault may have occurred. In this case, examine the machine to ascertain and eliminate the cause of the fault to ensure satisfactory operation.

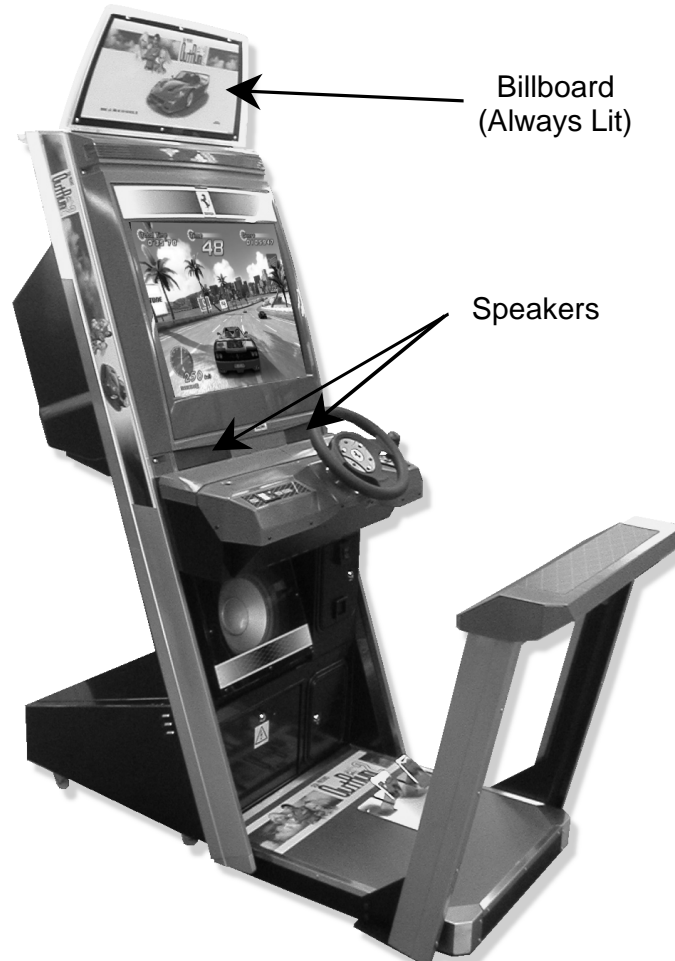

The LED and fluorescent light behind the billboard are always lit when the unit is on. When advertising (waiting for customers), the unit displays the advertising screen and outputs sound through the two speakers. It is possible to disable sound output during advertising from Test Mode.

4.1. Basic Controls

Insert a coin and press the Start Button to begin a game.

Choose your car, background music, and other options. View choices with the Steering Wheel, and enter your selection with the Gas pedal.

During game play, use the Gas pedal to accelerate your car, and the Brake pedal to stop. The Gear Shifter can be used to shift up and shift down when using Manual transmission.

You can switch between three different view settings with the View Change Button.

4.2. Game Outline

This is a driving game.

The player controls a car (Ferrari), listening to great music and enjoying roadside scenery in the company of a gorgeous female passenger, all while racing towards the goal before time is up.

The time limit is extended at each checkpoint.

The game ends when the player runs out of time or reaches the goal.

Each game stage ends with a fork in the road where the player must decide the route using the car during the race. There are a total of fifteen stages, and five separate goal areas.

The three single player game modes are OutRun Mode, Heart Attack Mode, and Time Attack Mode.

The game's Versus Mode accommodates play for up to four players.

Route Guide with Stage Names

					5A	Tulip Garden
				4A	Cloudy Highland	
		3A	Castle Wall		5B	Metropolis
	2A	Deep Lake		4B	Industrial Complex	
1A	Palm Beach		3B	Coniferous Forest	5C	Ancient Ruins
	2B	Alpine		4C	Snow Mountain	
		3C	Desert		5D	Imperial Avenue
				4D	Ghost Forest	
					5E	Cape Way

4.3. Game Flow

4.3.1. Versus Mode Entry

After inserting coins and pressing the Start Button, Versus Mode Entry prompts will be displayed for potential players at other game cabinets. Pressing the Start Button within the Versus Mode Entry period will start Versus Mode.

Closing Versus Mode Entry

To close Versus Mode entry, press the View Change Button and the Brake pedal at the same time before other players join. (Press the Brake pedal while holding down the View Change Button.)

Versus Mode entry time can also be run down to 0 by holding the Start Button, thus closing Versus Mode entry.

By closing Versus Mode entry in either of the above ways, the Single Player mode will commence, provided no players have already joined.

4.3.2. Car Selection



You can select the car model. In Single Player mode you can also change the car colour. Press the Brake pedal and Shifter together to change the car colour. (Press up or down on the shifter while holding down the Brake pedal.) These instructions will not be displayed on the screen.

Moving the Shifter up or down while holding down the Brake pedal will bring up a two-character car colour code just above the 'Gas Pedal: Enter Selection' indicator in the lower right corner of the screen. The colour codes are represented as follows: RE:red, YE:yellow, BK:black, WH:white, SL:silver, GR:green, LB:light blue, BU:blue.

Changing the car model in the middle of colour selection will automatically return the colour to the selected model's default colour, after which model and colour selection will again be possible. The selected car will then be displayed in the chosen colour at the start of the game.

The available colours vary from car to car. The colours available for each car are indicated by a 'Yes' in the chart below, and likewise, only these colours will be shown during selection.

Colour Chart

Car Type	Black	Blue	Green	Light Blue	Red	Silver	White	Yellow
F50	Yes	Yes	Yes	Yes	Yes	Yes	Yes	Yes
360 Spider	Yes	Yes	Yes	Yes	Yes	Yes	Yes	Yes
Dino 246 GTS	Yes	No	No	Yes	Yes	Yes	Yes	Yes
365 GTS/4 Daytona	Yes	No	No	Yes	Yes	Yes	Yes	Yes
Testarossa	Yes	No	No	No	Yes	Yes	No	Yes
288 GTO	Yes	No	No	Yes	Yes	No	Yes	Yes
Enzo Ferrari	Yes	No	No	No	Yes	Yes	No	Yes
F40	Yes	Yes	Yes	Yes	Yes	Yes	Yes	Yes

Player-selectable cars and their characteristics are shown below. The colour shown in parenthesis is the default colour.

F50 (RE), 360 Spider (RE)
(For INTERMEDIATE Player)

Acceleration : *****
Handling : *****
Top Speed : *****

Dino 246 GTS (YE), 365 GTS/4 Daytona (BK)
(For NOVICE Player)

Acceleration : *****
Handling : *****
Top Speed : *****

Testarossa (RE), 288 GTO (RE)
(For INTERMEDIATE Player)

Acceleration : *****
Handling : *****
Top Speed : *****

Enzo Ferrari (RE), F40 (RE)
(For PROFESSIONAL Player)

Acceleration : *****
Handling : *****
Top Speed : *****

4.3.3. Transmission Selection

You can choose between Automatic transmission and Manual transmission.

When Manual transmission is selected, the number of gears varies with the car model.

- 6-speed: F50, 360 Spider, Enzo Ferrari
- 5-speed: Dino 246 GTS, 365 GTS/4 Daytona, Testarossa, 288 GTO, F40

4.3.4. Mode Selection

In Single Player, you will choose a game mode.

4.3.4.1. OutRun Mode

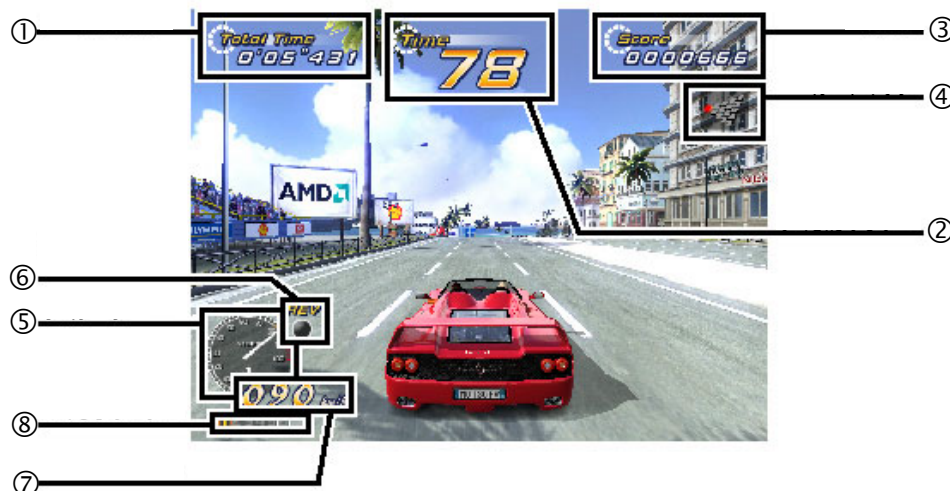

- 1) Total Time
- 2) Time Counter
- 3) Score
- 4) Route Map
- 5) Tachometer
- 6) Shift Up Indicator
- 7) Speed Meter
- 8) Shift Indicator

This is the pure driving mode, enjoyed with a young lady by your side. You select branching paths and try to reach the goal within the time limit. The game ending varies depending on which goal is reached.

4.3.4.2. Heart Attack Mode



1) Lady's Heart Meter

This is the mode where you raise the Lady's Heart Meter by fulfilling her requests. Collect as many of the hearts showing her feelings as possible. You must pursue her request for the duration of the indicated track section.

The Lady's Requests

- 'Drift more!'
Try drifting continuously throughout the track section.
- 'Keep passing cars!'
Pass as many cars as possible throughout the track section.
- 'Don't crash!'
Avoid hitting any other cars, walls, or obstacles throughout the track section.
- 'Run through red/blue!'
Drive on the indicated colour section of the roadway.



- 'Hit the blue cones!' There are twenty blue cones placed on the roadway—try to hit as many as you can.



- 'Cut the line!' Drive through the yellow heart lines between cars on the roadway. Lines cut once will not come back.



- 'Catch the Heart!' There are Hearts floating around on the roadway. Try your best to drive through the Hearts. Hearts collected once will not come back.



Special Requests

Satisfying certain conditions will open up Special Requests.

Ending

The game ending will change depending on your performance assessment.

4.3.4.3. Time Attack Mode



- 1) Sector Time
- 2) Position

This mode is a test of time in reaching the goal.

Player driving data is recorded for goal time, route best time, and slowest time. The player can then compete against his own time in subsequent plays.

When there is no player data recorded, a default data car will appear.

Ending

The game ending will change depending on your goal time.

Internet Ranking Password

If your time qualifies, you'll be given an Internet Ranking password. Using this password, you can participate in the Internet Ranking system.

Goal Choice

You can choose from five different destination goal points.

(This option is only available in the Time Attack Mode.)

Route Choice

After choosing a goal, you can decide on a specific route for that particular goal.

(This option is only available in the Time Attack Mode.)

There is one exception, however—Goal A, 'Tulip Garden', and Goal E, 'Cape Way' each have only one route so the Route Choice option will not be available.

Goal B, 'Metropolis', and Goal D, 'Imperial Avenue' each have four possible routes, while Goal C, 'Ancient Ruins' has six possible routes to choose from.

BGM Selection

There are seven different in-game songs to select from. In Versus Mode, each player can listen to his or her own individual selection.

- SPLASH WAVE (from original OutRun)
- MAGICAL SOUND SHOWER (from original OutRun)
- PASSING BREEZE (from original OutRun)
- Risky Ride (new)
- Shiny World (new)
- Night Flight (new, includes lyrics)
- Life was bore (new, includes lyrics)

4.4. Versus Play

4.4.1. Versus Mode Game Play

The car colours for versus mode are fixed for each player. 1P: Red, 2P: Yellow, 3P: White/Silver (depending on car model), 4P: Black

The position order on the starting grid is determined by the order of Versus Mode entry (decided by who presses the Start Button first).

The course is decided as the route taken by whoever first reaches a given course branch.

4.4.2. Special Versus Mode Commands

The 'No Handicap' and 'Player Only' modes are selectable with special commands entered at the game's selection screen.

4.4.2.1. No Handicap Mode

In the usual Versus Mode, the player in second place during a race can catch up easier with computer assistance, but this assistance isn't available in the No Handicap mode.

To activate No Handicap mode, all participants in the Versus Mode competition must press the Brake pedal together with the Shifter up. (Push the shifter up while holding down the Brake pedal.) An icon will be displayed on the right side of the selection screen when this mode is activated.

4.4.2.2. Player Only Mode

In Player Only mode, no cars besides the player-controlled cars will appear in the race.

To activate Player Only mode, all participants in the Versus Mode competition must press the Brake pedal together with the Shifter down. (Push the shifter down while holding down the Brake pedal.) An icon will be displayed on the right side of the selection screen when this mode is activated.



4.5. Gameplay Techniques And Secret Commands

4.5.1. How to Drift



After letting go of the Gas pedal, immediately press the Brake pedal. Then, quickly steer sharply into the turn and press the Gas pedal.

In the case of Manual transmission, shift down one gear just before the turn, then immediately steer sharply into the turn.

4.5.2. Mid-game Quit Command



You can quit in the middle of a game. This command is only possible in the Single Player mode.

To activate the mid-game quit command, stop the car and press the Brake pedal, View Change button, and Shifter up. (While holding down the Brake pedal, continue to hold down the View Change button, and finally press the Shifter up.)

After inputting the command, the player is prompted, 'Do you really want to quit this game? Yes/No'. Choosing 'Yes' will finish the game, and 'No' will return the player to the game.

There are three conditions under which this command cannot be executed:

- The player is near the starting grid.
- The remaining time is under 8 seconds.
- 'No' has already been chosen once.

4.6. Character Introductions

Three major characters appear in the game.

1. Driver

Name: Alberto

Personal Info: Although easy-going on the outside, he's a real go-getter.
He has a very distinguished driving sense. He's also quite rich.

2. OutRun Mode Lady

Name: Jennifer

Personal Info: She's a filthy rich 'princess', always selfishly seeking the next thrill. She's involved with Alberto, his Ferrari a present from her. She has a sharp eye for driving techniques.

3. Heart Attack Lady

Name: Clarissa

Personal Info: She's peppy and unmistakably sexy. A driving fan, with a weakness for thrill rides.
She's very demanding, but her sweet character makes her hard to dislike.

5. MAINTENANCE INSTRUCTIONS

5.1. Explanation Of Test Data And Display

Use the switches inside the Control Panel to enter the TEST MODE. This will allow you to carry out post installation and periodic checks and adjustments. The following Section details the function of each of the tests:

Refer to the service manual supplied with the Monitor for detailed instructions.

ITEM	DESCRIPTION	INTERVAL
INSTALLATION OF THE MACHINE	When the machine is installed perform the following checks: <ul style="list-style-type: none"> • Check to see that each setting is as per the standard settings input at the time of shipment. • In the INPUT TEST mode, check each switch and V.R. • In the OUTPUT TEST mode, check each of the lamps. • In the MEMORY TEST mode check all of the IC's on the IC BD. 	Monthly
MEMORY	<ul style="list-style-type: none"> • On the TEST MENU screen choosing the MEMORY TEST allows self test to be performed. In this test RAM & ROM are tested. 	Monthly
PERIODIC CHECKS	Periodically perform the following <ul style="list-style-type: none"> • MEMORY TEST. • Ascertain each setting. • In the INPUT TEST mode, test the control devices. • In the OUTPUT TEST mode, check each of the lamps. 	Monthly
CONTROL SYSTEM	<ul style="list-style-type: none"> • In the INPUT TEST mode, check each switch and V.R. • Adjust or replace each switch and V.R. 	Monthly
MONITOR	<ul style="list-style-type: none"> • In the C.R.T. TEST mode, check to ensure the monitor is adjusted correctly • Clean screen (switch off machine and remove the plug) 	Monthly Weekly
IC BOARD	MEMORY TEST <ul style="list-style-type: none"> • In the SOUND TEST mode, check the sound related ROMs 	Monthly
DATA CHECK	<ul style="list-style-type: none"> • Check such data as held in the bookkeeping screens, relating to number and length of plays 	Monthly
EXTERIOR MAINTENANCE	<ul style="list-style-type: none"> • Clean surfaces 	Monthly
COIN MECHANISM	<ul style="list-style-type: none"> • Check switch operation (if fitted) 	Monthly

5.2. Internal Switches And Coin Meters



- Never touch places other than those specified. Touching places not specified can cause electric shock and short circuits
- Be careful not to damage wiring. Damaged wiring can cause electric shock and short circuits.

- Adjust to the optimum sound volume considering the environmental requirements of the installation location.
- If the COIN METER and the game board are electrically disconnected, game play is not possible.

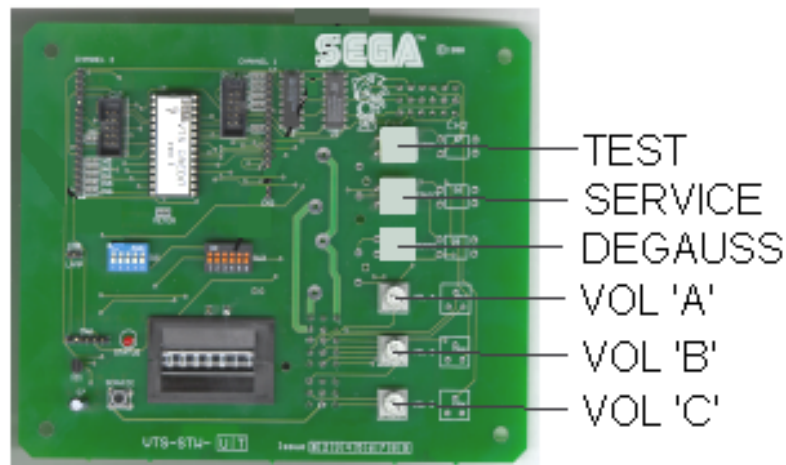

Open the Coin Chute door to access the VTS PCB. The function of each switch is as follows.

TEST BUTTON (TEST SW)	Used to enter TEST mode. Also has function during TEST mode. Refer to the later Section detailing TEST mode.
SERVICE BUTTON (SERVICE SW)	Gives credits without registering on the coin counter. Also used during TEST mode.
DEMAG	Eliminates colour unevenness from the monitor screen.
VOLUME CONTROL	Adjusts the volume of the speakers.

5.3. System Test Mode



- The contents of settings changed in the TEST mode are stored when the test mode is finished from EXIT in the menu mode. If the power is turned off before the TEST mode is finished, the contents of setting change become ineffective.
- Executing "BACKUP DATA CLEAR" in the SYSTEM TEST MODE does not clear the BOOKKEEPING data in the GAME TEST mode.
- Entering the TEST mode clears fractional number of coins less than one credit and BONUS ADDER data.
- Perform setting as per specified in this manual for operation. If setting not specified is performed for operation, proper function of this product may not be obtained.

In the SYSTEM TEST MODE, IC BD functioning can be checked, the monitor adjusted, and the coin setting performed.

Refer to NAOMI NETWORK SYSTEM SERVICE MANUAL for the details. Note that the setting of the following items need to be performed in accordance with the instruction given.

CABINET TYPE : 1 PLAYER(S)
 MONITOR TYPE : HORIZONTAL
 SERVICE TYPE : COMMON
 COIN CHUTE TYPE : COMMON
 NETWORK TYPE : NONE

The SEQUENCE SETTING items of COIN/CREDIT SETTING are as follows.

SEQUENCE SETTING

- SEQUENCE 1: Number of credits required for starting the game.
 SEQUENCE 2: Number of credits required for continuing the play.
 SEQUENCE 3: Number of credits required for dedicated CARD purchase.
 SEQUENCE 4 -8: NOT USED

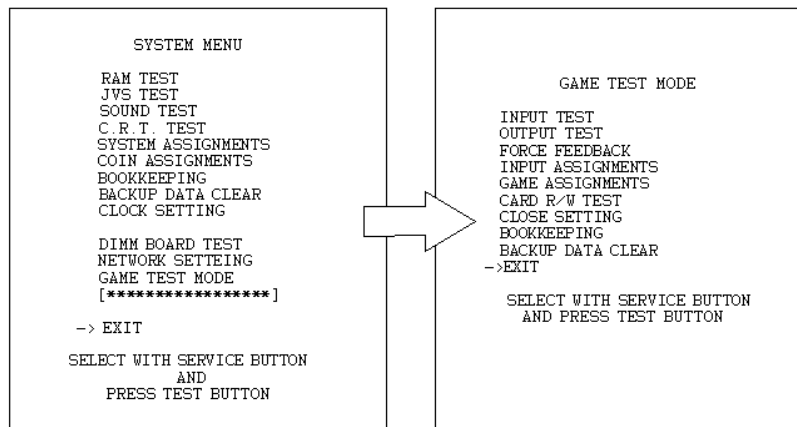

SYSTEM TEST MODE MENU Screen

GAME TEST MENU Screen

Press the TEST BUTTON to bring up the screen shown to the left.
 Press the SERVICE BUTTON to move downwards through the list. The arrow shows the current selection.
 Press the TEST BUTTON to activate the selected test.
 To finish TEST MODE, move the arrow to EXIT and press the TEST.

5.3.1. RAM Test

```

RAM TEST

IC15 IC16 IC17S IC18S GOOD
IC22 IC23 IC24S IC25S GOOD
IC28 IC29S          GOOD
IC41                GOOD
IC42                GOOD
IC44 IC45S IC46 IC47S GOOD
IC91S IC92S        GOOD
IC98                GOOD

OPTIONAL SOUND BOARD:
IC2                GOOD

OPTIONAL COMMUNICATION BOARD:
IC7 IC8 IC9 IC10 GOOD

PRESS TEST BUTTON TO EXIT

```

The memory test mode is for automatically checking the on-board memory IC functioning. "GOOD" is displayed for normal IC's and "BAD " for abnormal IC's

- When the test is completed, if the results are as shown on the left then the Game Board is satisfactory.
- The test should take approximately thirty seconds to complete. If the test exceeds this time the board may have malfunctioned.
- After finishing the test press the TEST BUTTON or START BUTTON to exit.

5.3.2. JVS Test

```

JVS TEST
INPUT TEST
> EXIT

NODE      1/1
NAME      SEGA ENTERPRISES,LTD. ;837-13741
          I/O CONTROL BD2;Ver0.15;99/06
CMD VER   1.1
JVS VER   2.0
COM VER   1.0
SWITCH    2PLAYERS 12BITS
COIN      2SLOTS
ANALOG    8CH
DRIVER OUT 22CH

SELECT WITH SERVICE BUTTON
AND
PRESS TEST BUTTON

```

- In this test, functioning of the I/O Board connected to the Game Board is displayed, and INPUT TEST can be performed. Select EXIT to return to the MENU screen, or select INPUT TEST to display the second screen.

```

JVS TEST
> DISPLAY CONFIG
EXIT

NODE      1/1
SWITCH    _____
SYSTEM    _____
PLAYER1   _____
PLAYER2   _____
COIN      _____
          SLOT1 0000  SLOT2 8000
ANALOG    _____
          CH1 0000 CH2 0000 CH3 0000 CH4 0000
          CH5 0000 CH6 0000 CH7 0000 CH8 0000

SELECT WITH SERVICE BUTTON
AND
PRESS TEST BUTTON

```

With a switch input from the control panel etc., this changes into 1.

With a coin switch input, this accumulates. And, the coin meter counts.

Analogue values are displayed between 0000 and FF00.

Select EXIT to return to the MENU screen.

5.3.3. Sound Test

Select the sound test to check the status of the amplifiers, soundboards, and speakers.

Press the SERVICE button or view change button to move the arrow to the desired test item.

Press TEST button to output the sound.

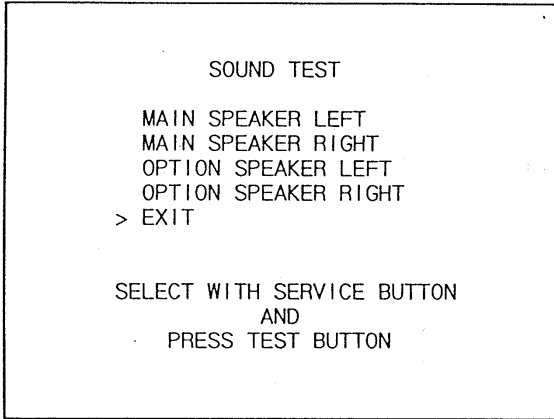

- Select the sound source with SERVICE.
- On pressing TEST, the test sound is emitted from the selected source.

Select EXIT to return to MENU screen.

5.3.4. C.R.T Test

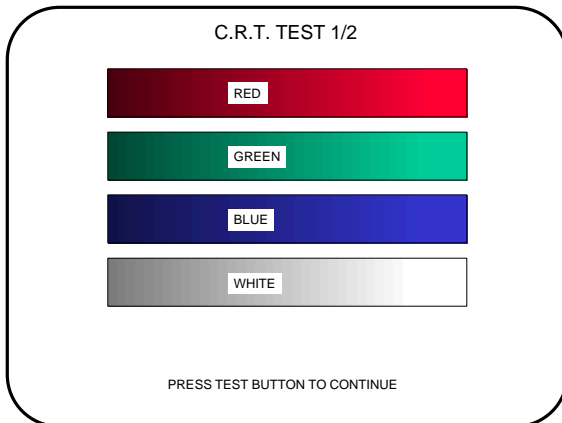

Selecting CRT test allows the projector adjustment to be checked for colour and distortion.

Press the test or start button to have the second CRT test screen appear.

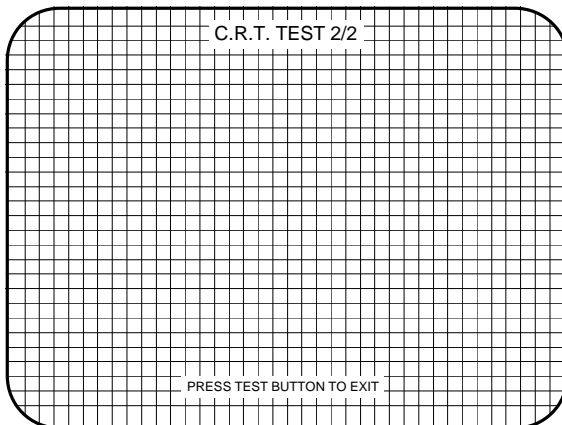

5.3.5. System Assignments

Allows system options to be set. Select required setting with SERVICE button, confirm with TEST button. Default settings are indicated in parentheses.

```
SYSTEM ASSIGNMENTS

CABINET TYPE          1PLAYER
ADVERTISE SOUND      ON
MONITOR TYPE         HORIZONTAL
DISPLAY MODE        AUTOSCAN
SERVICE TYPE        COMMON
COMMUNICATION MODE   MASTER
> EXIT

SELECT WITH SERVICE BUTTON
      AND
PRESS TEST BUTTON
```

- CABINET TYPE specifies Control Panel and number of Coin Chutes. The number of players displayed in BOOKKEEPING varies in accordance with the value displayed here. (**1PLAYER**)
- ADVERTISE SOUND allows the sound emission to be turned (**ON**) or OFF during ADVERTISE MODE.
- MONITOR TYPE changes the orientation of the image on the screen (**HORIZONTAL**)
- SERVICE TYPE sets the functioning of the SERVICE button, should several SERVICE buttons exist. **INDIVIDUAL**: Service credit is applied to the machine on which the SERVICE button is pressed. (**COMMON**): Service credit is applied to all machines when SERVICE button is pressed.

5.3.5.1. Coin Assignments

```
COIN ASSIGNMENTS
COIN CHUTE TYPE      COMMON
COIN/CREDIT SETTING #1
COIN CHUTE #1
  1COIN 1CREDIT

COIN CHUTE #2
  1COIN 1CREDIT

MANUAL SETTING
SEQUENCE SETTING
> EXIT

SELECT WITH SERVICE BUTTON
      AND
PRESS TEST BUTTON
```

Select the coin assignments mode to set the coin to credit ratios.

This can be any of the pre-set values or can be done manually.

5.3.5.2. Coin/Credit Setting (Coin Chute Common Type)

SETTING	FUNCTIONING OF COIN CHUTE #1		FUNCTIONING OF COIN CHUTE #2	
SETTING #1	1 COIN	1 CREDIT	1 COIN	1 CREDIT
SETTING #2	1 COIN	2 CREDITS	1 COIN	1 CREDIT
SETTING #3	1 COIN	3 CREDIT	1 COIN	1 CREDIT
SETTING #4	1 COIN	4 CREDITS	1 COIN	1 CREDIT
SETTING #5	1 COIN	5 CREDITS	1 COIN	1 CREDIT
SETTING #6	1 COIN	2 CREDITS	1 COIN	2 CREDITS
SETTING #7	1 COIN	5 CREDITS	1 COIN	2 CREDITS
SETTING #8	1 COIN	3 CREDITS	1 COIN	3 CREDITS
SETTING #9	1 COIN	4 CREDITS	1 COIN	4 CREDITS
SETTING #10	1 COIN	5 CREDITS	1 COIN	5 CREDITS
SETTING #11	1 COIN	6 CREDITS	1 COIN	6 CREDITS
SETTING #12	2 COINS	1 CREDIT	2 COINS	1 CREDIT
SETTING #13	1 COIN	1 CREDIT	2 COINS	1 CREDIT
SETTING #14	1 COIN	2 CREDITS	2 COINS	1 CREDIT
SETTING #15	1 COIN 2 COINS	1 CREDIT 3 CREDITS	1 COIN 2 COINS	1 CREDIT 3 CREDITS
SETTING #16	1 COIN	3 CREDITS	1 COIN 2 COINS	1 CREDIT 3 CREDITS
SETTING #17	3 COINS	1 CREDIT	3 COINS	1 CREDIT
SETTING #18	4 COINS	1 CREDIT	4 COINS	1 CREDIT
SETTING #19	1 COIN 2 COINS 3 COINS 4 COINS	1 CREDIT 2 CREDITS 3 CREDITS 5 CREDITS	1 COIN 2 COINS 3 COINS 4 COINS	1 CREDIT 2 CREDITS 3 CREDITS 5 CREDITS
SETTING #20	1 COIN	5 CREDITS	1 COIN 2 COINS 3 COINS 4 COINS	1 CREDIT 2 CREDITS 3 CREDITS 5 CREDITS
SETTING #21	5 COINS	1 CREDIT	5 COINS	1 CREDIT
SETTING #22	1 COIN	2 CREDITS	3 COINS 5 COINS	1 CREDIT 2 CREDITS
SETTING #23	2 COINS 4 COINS 5 COINS	1 CREDIT 2 CREDITS 3 CREDITS	2 COINS 4 COINS 5 COINS	1 CREDIT 2 CREDITS 3 CREDITS
SETTING #24	1 COIN	3 CREDITS	2 COINS 4 COINS 5 COINS	1 CREDIT 2 CREDITS 3 CREDITS
SETTING #25	1 COIN 2 COINS 3 COINS 4 COINS 5 COINS	1 CREDIT 2 CREDITS 3 CREDITS 4 CREDITS 6 CREDITS	1 COIN 2 COINS 3 COINS 4 COINS 5 COINS	1 CREDIT 2 CREDITS 3 CREDITS 4 CREDITS 6 CREDITS
SETTING #26	1 COIN	6 CREDITS	1 COIN 2 COINS 3 COINS 4 COINS 5 COINS	1 CREDIT 2 CREDITS 3 CREDITS 4 CREDITS 6 CREDITS
SETTING #27	FREE PLAY		FREE PLAY	

5.3.5.3. Coin/Credit Setting (Coin Chute Individual Type)

SETTING	FUNCTIONING OF COIN CHUTE #1	
SETTING #1	1 COIN	1 CREDIT
SETTING #6	1 COIN	2 CREDITS
SETTING #8	1 COIN	3 CREDITS
SETTING #9	1 COIN	4 CREDITS
SETTING #10	1 COIN	5 CREDITS
SETTING #11	1 COIN	6 CREDITS
SETTING #12	2 COINS	1 CREDIT
SETTING #15	1 COIN	1 CREDIT
	2 COINS	3 CREDITS
SETTING #17	3 COINS	1 CREDIT
SETTING #18	4 COINS	1 CREDIT
SETTING #19	1 COIN	1 CREDIT
	2 COINS	2 CREDITS
	3 COINS	3 CREDITS
	4 COINS	5 CREDITS
SETTING #21	5 COINS	1 CREDIT
SETTING #22	3 COINS	1 CREDITS
	5 COINS	2 CREDITS
SETTING #23	2 COINS	1 CREDIT
	4 COINS	2 CREDITS
	5 COINS	3 CREDITS
SETTING #25	1 COIN	1 CREDIT
	2 COINS	2 CREDITS
	3 COINS	3 CREDITS
	4 COINS	4 CREDITS
	5 COINS	6 CREDITS
SETTING #27	FREE PLAY	

5.3.5.4. Manual Setting

```

COIN ASSIGNMENTS
MANUAL SETTING

COIN TO CREDIT          1
BONUS ADDER            0
COIN CHUTE #1 MULTIPLIER
1 COINCOUNT AS        1COIN
COIN   1  2  3  4  5  6  7  8  9
CREDIT 1  2  3  4  5  6  7  8  9

COIN CHUTE #2 MULTIPLIER
1 COINCOUNT AS        1COIN
COIN   1  2  3  4  5  6  7  8  9
CREDIT 1  2  3  4  5  6  7  8  9

SEQUENCE SETTING
> EXIT

SELECT WITH SERVICE BUTTON
AND
PRESS TEST BUTTON
    
```

Select manual setting to manually set the coin to credit ratios.

The available combinations are detailed below.

MANUAL SETTING

COIN TO CREDIT	1 COIN	1 CREDIT
	2 COINS	1 CREDIT
	3 COINS	1 CREDIT
	4 COINS	1 CREDIT
	5 COINS	1 CREDIT
	6 COINS	1 CREDIT
	7 COINS	1 CREDIT
	8 COINS	1 CREDIT
	9 COINS	1 CREDIT

BONUS ADDER	NO BONUS ADDER
	2 COINS GIVE 1 EXTRA COIN
	3 COINS GIVE 1 EXTRA COIN
	4 COINS GIVE 1 EXTRA COIN
	5 COINS GIVE 1 EXTRA COIN
	6 COINS GIVE 1 EXTRA COIN
	7 COINS GIVE 1 EXTRA COIN
	8 COINS GIVE 1 EXTRA COIN
	9 COINS GIVE 1 EXTRA COIN

COIN CHUTE MULTIPLIER	1 COIN COUNTS AS 1 COIN
	1 COIN COUNTS AS 2 COINS
	1 COIN COUNTS AS 3 COINS
	1 COIN COUNTS AS 4 COINS
	1 COIN COUNTS AS 5 COINS
	1 COIN COUNTS AS 6 COINS
	1 COIN COUNTS AS 7 COINS
	1 COIN COUNTS AS 8 COINS
	1 COIN COUNTS AS 9 COINS

5.3.5.5. Sequence Setting

Selecting SEQUENCE SETTING allows the number of credits required to start the game to be set. Each sequence can be set between 1 and 5. Select EXIT to return to the first screen.

```
COIN ASSIGNMENTS
SEQUENCE SETTING

SEQUENCE1 *CREDIT
SEQUENCE2 *CREDIT
SEQUENCE3 *CREDIT
SEQUENCE4 *CREDIT
SEQUENCE5 *CREDIT
SEQUENCE6 *CREDIT
SEQUENCE7 *CREDIT
SEQUENCE8 *CREDIT
> EXIT

[XXXXXXXXXXXXXXXXXX]
[ SEGA ENTERPRISES,LTD. ]
DESCRIPTION OF SEQUENCE
SE01 TO START
SE02 TO CONTINUE
SE03 TO MAKE CARD
SE04 NOT USED
SE05 NOT USED
SE06 NOT USED
SE07 NOT USED
SE08 NOT USED

SELECT WITH SERVICE BUTTON
AND
PRESS TEST BUTTON
```

5.3.5.6. Bookkeeping

```
BOOKKEEPING PAGE#1

TOTAL TIME      55H27M13S
COIN1           16 SERVICE1      5
COIN2           4 SERVICE2      0
CREDIT          10

TOTAL COIN      20
COIN CREDIT     10
SERVICE CREDIT  5
TOTAL CREDIT    15

PRESS SERVICE BUTTON TO ANOTHER PAGE
PRESS TEST BUTTON TO EXIT
```

```
BOOKKEEPING PAGE#2

PLAYER1
SE01      1
SE02      0
SE03      1
SE04      0
SE05      0
SE06      0
SE07      0
SE08      0

PRESS SERVICE BUTTON TO ANOTHER PAGE
PRESS TEST BUTTON TO EXIT
```

This mode consists of 2 pages that allow the data relating to credit and game play time to be checked.

In page 1 mode press SERVICE to proceed to page 2, in page 2 mode press TEST to return to the test menu.

- Total time is displayed as XXH XXM XXS and no date will be displayed after exceeding 24 hours.
- The displays for number of coin and number of service vary depending on the CABINET TYPE set in SYSTEM ASSIGNMENTS. Number of credit displays 1 if COIN CHUTE TYPE is set to COMMON in COIN ASSIGNMENTS. If COIN CHUTE TYPE is set to INDIVIDUAL, the applicable number in CABINET TYPE setting will be displayed.
- On the second screen, each sequence displays the frequency of functioning.

5.3.5.7. Backup Data Clear

```
BACKUP DATA CLEAR

YES (CLEAR)
> NO (CANCEL)

SELECT WITH SERVICE BUTTON
AND
PRESS TEST BUTTON
```

Clears the contents of bookkeeping. When clearing, bring the arrow to "YES (CLEAR)" and press the test button. When the data has been cleared "COMPLETED" will be displayed. Bring the arrow to "NO (CANCEL)" and press the test button to return to the menu mode.

Note that this does not clear the contents of BOOKKEEPING in GAME TEST MODE. For this, use the BACKUP DATA CLEAR in GAME TEST MODE.

5.3.5.8. ROM BD Test

In this test, Game Board ROM is checked. If GOOD is displayed, it is satisfactory. The IC number, TYPE, BYTE and WORD refer to the checksum of each unit. Press TEST to exit.

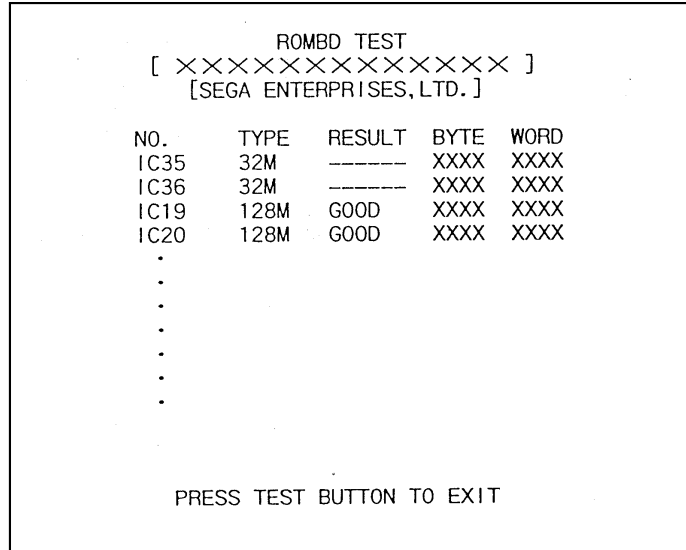

On above screen, IC35 and IC36 (program ROMs) do not display GOOD or BAD. Press TEST Button to EXIT.

5.3.5.9. Clock Setting

YEAR, MONTH, DAY, HOUR and MINUTE are set for GAME BOARD. Select the desired item with SERVICE button and press TEST to increase the value. Select EXIT to return to MENU mode.

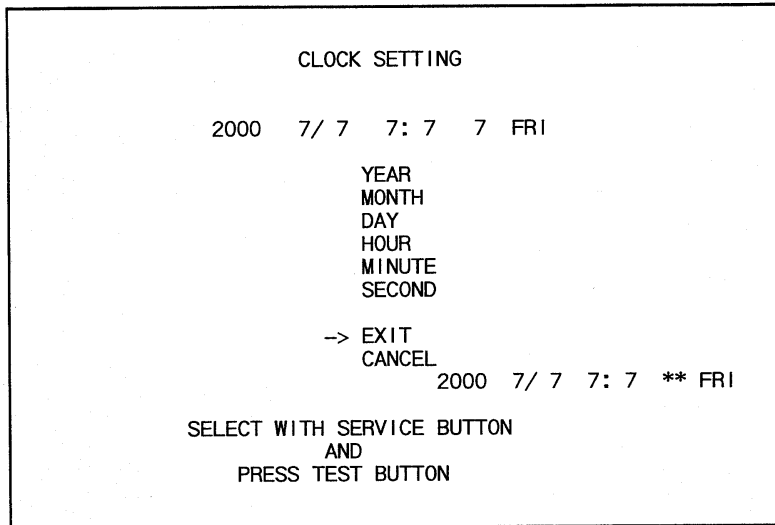

5.4. Game Test Mode

[IMPORTANT]

When changing the game configuration, changes will not be enabled until the Game Test Mode has been completed. Be sure to exit the Game Test Mode properly after configuration changes.

Select GAME TEST MODE from the System Menu screen to display the Game Test Menu screen as follows.

Use the SERVICE Button to move the cursor to the desired test item. Press the TEST Button to enter the selected item.

NOTE: In Upright cabinet types, the DRIVE BOARD TEST is not necessary and the option will not be displayed.

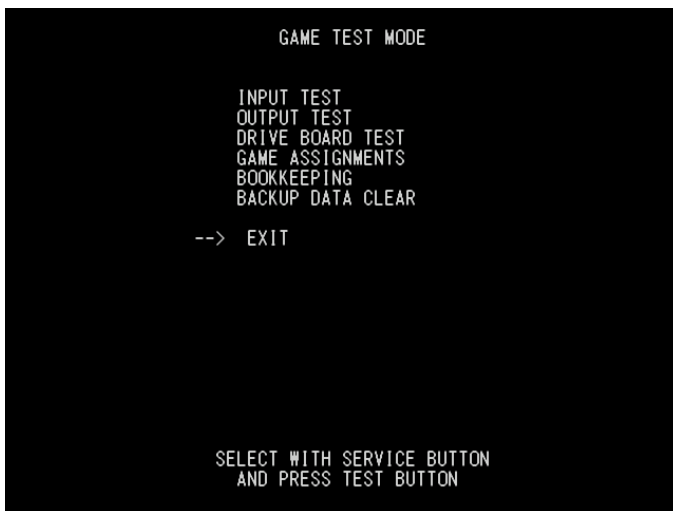

After selecting an item, read the explanations below regarding operation.

After the test is complete, move the cursor to EXIT and press the TEST Button to return to the System Menu screen.

5.4.1. Input Test

Select INPUT TEST to display the following screen and check the status of input devices. This test should be used periodically to check that each input device is functioning correctly.

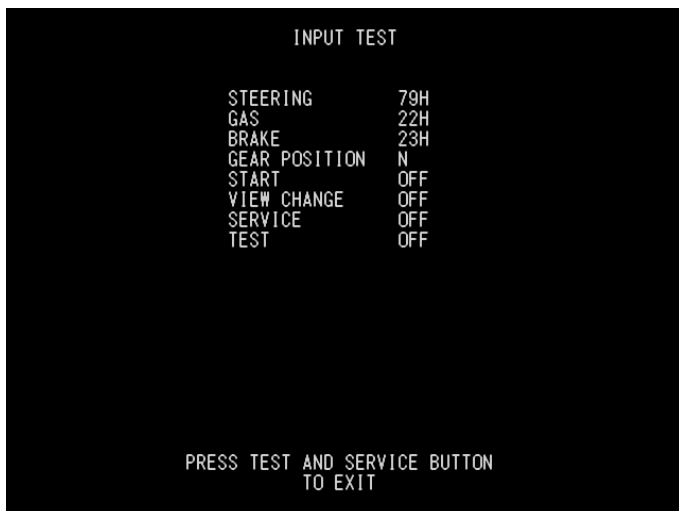

Test the STEERING, GAS (ACCEL) and BRAKE controls to ensure that they are functioning properly and that the parameters change smoothly as each input device is operated.

Display N, UP and DOWN using the GEAR POSITION. N displays that there is no control input. Verify that both UP and DOWN display in sync with the position of the shift knob.

Press the START, CHANGE VIEW, SERVICE and TEST Buttons. If functioning correctly, each indicator will switch from OFF to ON.

Press the SERVICE and TEST Buttons simultaneously to return to the Game Test Menu screen.

5.4.2. Output Test

Select OUTPUT TEST to display the following screen and check the status of each lamp. This test should be used periodically to check that the lamps are functioning correctly.

On this screen the cursor will switch automatically between items, lighting up the respective lamps.



- START BUTTON : Lights up the START button.
- VIEW CHANGE BUTTON: Lights up the View Change button.

Press the TEST Button to return to the Game Test Menu screen.

5.4.3. Drive Board Test

Select DRIVE BOARD TEST to display the following screen and check the status of steering motor.

Use the SERVICE Button to select the desired test item. Press the TEST Button to activate the selected item.

NOTE: This test will not be displayed in Upright cabinet types.

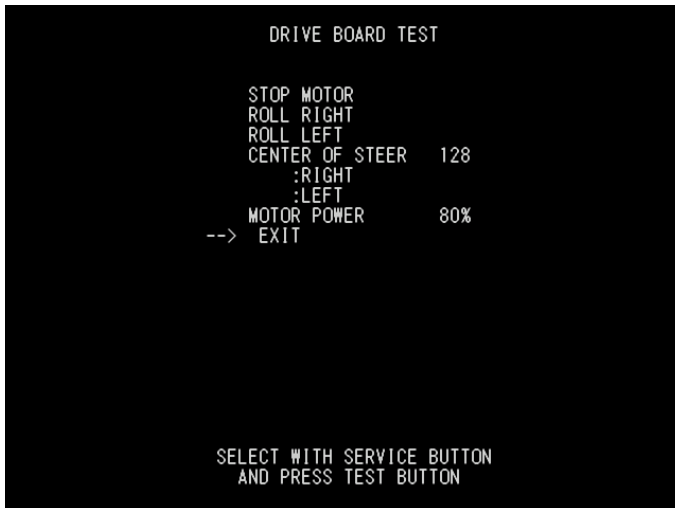

- STOP MOTOR: Halts motor activity.
- ROLL RIGHT: Rotates steering wheel completely to the right.
- ROLL LEFT: Rotates steering wheel completely to the left.
- CENTER OF STEER: Steering wheel motor's center of control is displayed.
 - RIGHT: Moves center of control position to the right.
 - LEFT: Moves center of control position to the left.
- MOTOR POWER: Sets the steering resistance.
There are four levels to choose from, 100% (strong resistance), 90%, 80%, and 60% (weak resistance). (80% is the default setting)

After changing the settings, select EXIT and press the TEST Button to return to the Game Test Menu screen.

5.4.4. Game Assignments

Select GAME ASSIGNMENTS to display the current game settings and make changes.

Changes to settings are not enabled until Test Mode is exited. After changing settings, be sure to exit Test Mode.

NOTE: When adjusting network play settings, DIFFICULTY, ADVERTISE SOUND, LANGUAGE, SPEEDOMETER, and QUICK START items will be decided by the cabinet with LINK_ID "1". Changes made to the game display or settings during game play do not affect the Game Test Menu settings.

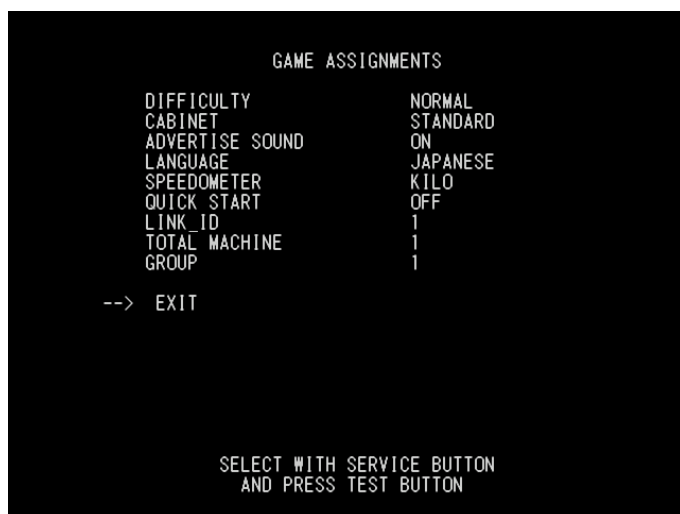

Perform the following settings for each item.

? DIFFICULTY: The game difficulty setting. There are 5 difficulty levels with VERY EASY being the easiest setting and VERY HARD being the most difficult setting. (Default Setting: NORMAL)

? CABINET TYPE: The game cabinet type setting. Choose from either STANDARD or UPRIGHT.

? ADVERTISE SOUND: The setting to turn the advertising sound ON/OFF. (Default Setting: ON)

? LANGUAGE: The game language setting. Choose from either JAPANESE or ENGLISH. (With JAPAN as the Country Setting, the default LANGUAGE setting is JAPANESE. ENGLISH is set as the default for a Country Setting of USA or EXPORT.)

? SPEEDOMETER: The speed display setting. During game play, KILO will be displayed as "km/h", and MILE as "mph". Choose one of these options. (With JAPAN or EXPORT as the Country Setting, the default SPEEDOMETER setting is KILO (km/h). MILE (mph) is set as the default for a Country Setting of USA.)

? QUICK START: Choose OFF or ON. The ON setting takes the player directly to the game selection screen after entering credits into the machine. (Default Setting: OFF)

? LINK_ID: The setting which determines the Player Number of each cabinet. It assigns unique numbers for cabinets in a single group. Do not assign two or more cabinets the same number. For network play, it is necessary to complete the LINK_ID, TOTAL MACHINE, and GROUP settings for each cabinet. (Default Setting: 1, Maximum: 4)

? TOTAL MACHINE : The number of network connected game cabinets. (Sets the number of competing cabinets in Versus Mode.) Setting this to "1" limits possible play modes to Single Player mode only. (Default Setting: 1, Maximum: 4)

? GROUP: Used for dividing networked cabinets into groups. For example, to split up a group of four networked machines into two groups of two cabinets, set two cabinets to "1" and the other two cabinets to "2". Generally, setting all cabinets to "1" is recommended.

After changing the settings, select EXIT and press the TEST Button to return to the Game Test Menu screen.

<Network Versus Mode Cabinet Settings>

Cases for four cabinets (A, B, C, and D) connected via network cable.

4-Cabinet Versus

CABINET	A	B	C	D
LINK_ID	1	2	3	4
TOTAL MACHINE	4	4	4	4
GROUP	1	1	1	1
Status	Four cabinets can compete.			

3-Cabinet Versus

CABINET	A	B	C	D
LINK_ID	1	1	2	3
TOTAL MACHINE	1	3	3	3
GROUP	1	2	2	2
Status	Single play only.	Three cabinets can compete.		

2-Cabinet Versus

CABINET	A	B	C	D
LINK_ID	1	2	1	2
TOTAL MACHINE	2	2	2	2
GROUP	1	1	2	2
Status	Two cabinets can compete.		Two cabinets can compete.	

5.4.5. Bookkeeping

Selecting BOOKKEEPING will display the following screen. All up-to-date operation data will be displayed on two BOOKKEEPING screens.

Use the TEST Button to cycle between the first screen (BOOKKEEPING 1/2) and the second screen (BOOKKEEPING 2/2).

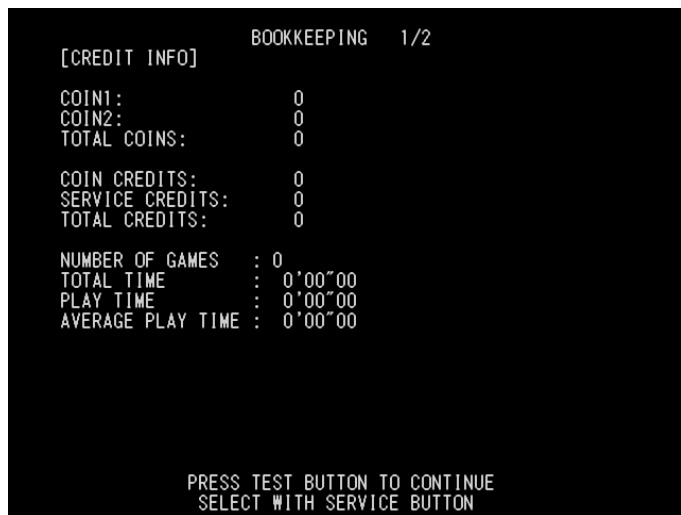

- ? COIN CHUTE #1: The number of coins inserted into Coin Slot 1.
- ? COIN CHUTE #2: The number of coins inserted into Coin Slot 2.
- ? TOTAL COINS: The total number of coins inserted into the coin slots.

- ? COIN CREDITS: The number of credits for the coins inserted.
- ? SERVICE CREDITS: The number of credits input by the SERVICE Button.
- ? TOTAL CREDITS: Total credits from coins and the SERVICE Button.

- ? NUMBER OF GAMES: The total number of games played.
- ? TOTAL TIME: The amount of time the unit has been in operation.
- ? PLAY TIME: Total playing time.
- ? AVERAGE PLAY TIME: Total play time divided by the total number of games played.

Press the TEST Button to move to screen 2/2 of BOOKKEEPING.

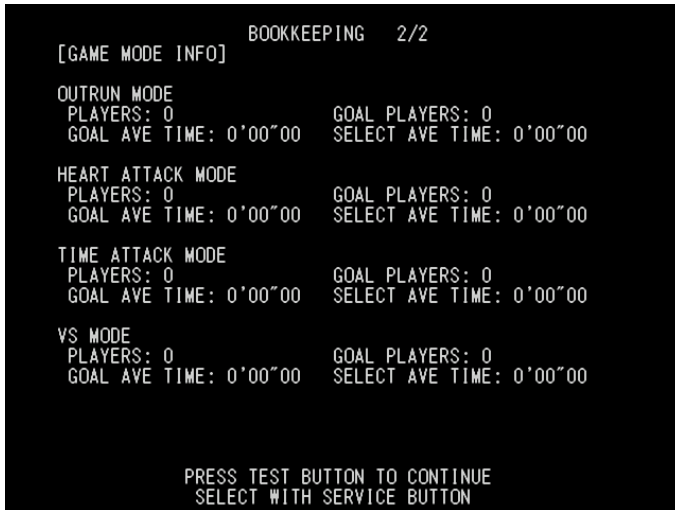

This shows the number of plays and the respective play times. This histogram should be referred to when setting the Game Difficulty.

Press the TEST Button to return to the Game Test Menu screen.

5.4.6. Backup Data Clear

Select BACKUP DATA CLEAR to clear the contents of BOOKKEEPING, ranking data and coin/credit data.

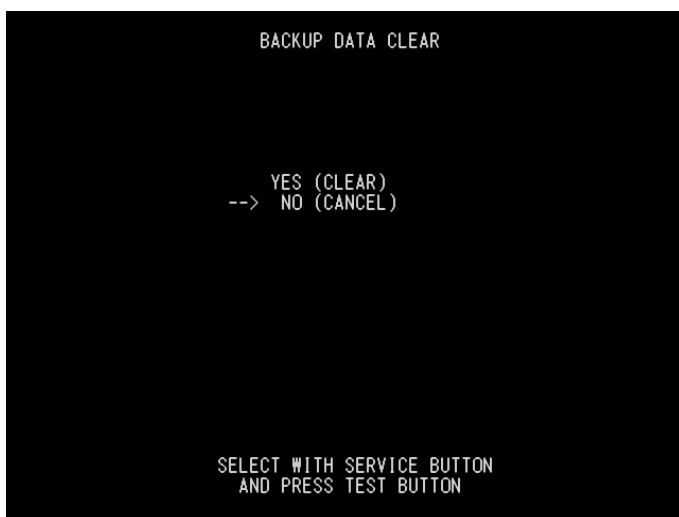

To clear data, use the SERVICE Button to move the cursor to YES (CLEAR) and then press the TEST Button. When the data has been cleared, the message "COMPLETED" will be displayed.

Press the TEST Button again to return to the Game Test Menu screen.

Move the cursor to NO (CANCEL) and press the TEST Button to return to the Game Test Menu screen without clearing the data.

Note that this operation does not affect GAME ASSIGNMENTS or GUN ADJUSTMENT settings.

5.5. Network Play

It is possible to link upto four machines and enable network play.

This is accomplished via a hub in a 'Master' machine linked through LAN cables with all participating machine's game boards.

Please enquire with SEGA Sales using the address at the rear of this manual about the availability of a 'Network Play Kit'

6. COIN MECH INSTALLATION AND CREDIT BOARD SET UP

6.1. Introduction

A VTS board controls game credits between the Coin Mechanism and the game board for this machine. This electronic circuit allows the price of play to be set for a range of different countries. These functions are set on Dual In Line (DIL) PCB mounted switches.

SW1 is used to set the currency (or coin ratio) and SW3 the price of play. Refer to the Tables on the following pages for the correct settings for your environment.

The VTS board pictured below is mounted in the Coin Chute Tower.

The VTS board is connected to the coin validator and lamps via a dedicated wiring harness depending upon the coin validator used:

Wiring Harness	Validator	
LM1006	Coin Controls	(15 way connector)
LM1007	Mars	(13 way connector)
LM1008	Mechanical	See note 2
N/A	NRI	See note 1

Notes

1. If NRI mechanisms are to be used, these should be ordered with the highest denomination coin on coin path #1 and the lowest denomination on coin path #4. The VTS board should be then be set up for either the UK or Switzerland settings. A minimum connecting lead length of 600mm is required.
2. Mechanical coin mechanisms may be connected in parallel allowing two identical mechanisms to be fitted.

The VTS Board

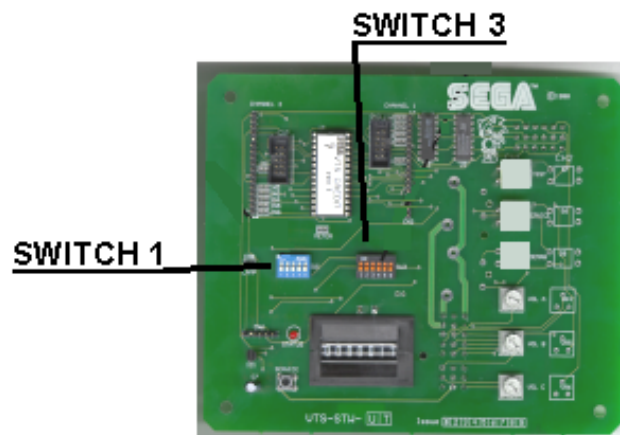

Credit Board Mode Settings Switch 3																			
Country	Setting	Switch 3 Setting						Coin Validator Programming								C120/SR3 Only			
		SW1	SW2	SW3	SW4	SW5	SW6	COIN1	COIN2	COIN3	COIN4	COIN5	COIN6	COIN7	COIN8	COIN9	COIN10	COIN11	COIN12
UK	Coin Controls C220 Parallel	OFF	OFF	OFF	OFF			£1	50p new	20p	10p	-	50p old	-	-				
UK	Coin Controls C220 Binary	ON	OFF	OFF	OFF			£1	50p new	20p	10p	-	50p old	-	£2				
UK	Coin Controls C220 Binary	OFF	ON	OFF	OFF			£1	50p new	20p	10p	-	£2	-	50p old				
UK	Coin Controls SR3 Parallel	ON	ON	OFF	OFF			£1	50p new	20p	10p	-	£2	-	50p old	-	-	-	
UK Euro	Coin Controls SR3 Parallel	OFF	OFF	ON	OFF			£2 €2	£1 €1	50p new 50¢	20p 20¢	10p 10¢	-	-	-	50p old	-	-	
UK	Mars ME/MS 111 Parallel	ON	OFF	ON	OFF			£1	£2	20p	10p	50p new	50p old						
UK	NRI Parallel	OFF	ON	ON	OFF			10p	20p	50p	£1	£2	-						
Belgium	Parallel	ON	ON	ON	OFF			-	50Bfr	20Bfr	5Bfr								
Holland	Parallel	OFF	OFF	OFF	ON			-	5NLG	2.5NLG	1NLG								
Austria	SR3 Parallel	ON	OFF	OFF	ON			20Sch	10Sch	5Sch	1Sch								
Spain	Coin Controls C220 Binary	OFF	ON	OFF	ON			500Pta	200Pta	100Pta	50Pta	25Pta	200Pt old	50Pta old	25Pta old				
Spain	SR3/NRI Parallel	ON	ON	OFF	ON			500Pta	200Pta	100Pta	50Pta	25Pta	-	-	200Pta	-	50Pta old	25Pta old	
Spain	Coin Controls C220 Parallel	OFF	OFF	ON	ON			100Pta	50Pta new	-	25Pta new	-	50Pta old	-	25Pta old				
Portugal Euro	Parallel	ON	OFF	ON	ON			200Es €1	100Es 50¢	50Es	-	-	-	-	-				
	TBA					OFF		TBA					<p align="center">Please Note</p> <p>The credit board automatically sets the validator for parallel and binary operation through an output on pin 8 of the 17 way pinstrip. For the feature to work it is necessary for the validator interconnecting cable to include at wire at this position</p>						
						ON		TBA											
	Channels						OFF	Direct Mode											
							ON	2 channel Mode											

Note: These switch settings are under constant review and may change due to world currency updates.

- Set SW 1 according to the option settings found in the relevant Price of Play Settings Table on the following pages.
- For Germany (DM), France (Fr) & Switzerland (SFr), use the appropriate existing setting shown above (from another country) that matches the coin ratios programmed into your coin mech
- Set SW 3 on the VTS/Excel board as shown in the table above corresponding to the country required.

6.1.1. Price Of Play Settings UK

	Price	Bonus			DIL Switch 1				
					Switch 1	Switch 2	Switch 3	Switch 4	Switch 5
1	10p	No Bonus			OFF	OFF	OFF	OFF	OFF
2	10p	6 = 50p			ON	OFF	OFF	OFF	OFF
3	20p	No Bonus			OFF	ON	OFF	OFF	OFF
4	20p	3 = 50p	6 = £1	12 = £2	ON	ON	OFF	OFF	OFF
5	30p	No Bonus			OFF	OFF	ON	OFF	OFF
6	30p	1.66 = 50p	4 = £1	8 = £2	ON	OFF	ON	OFF	OFF
7	30p	2 = 50p	4 = £1		OFF	ON	ON	OFF	OFF
8	30p	AMLD	3 = £1	6 = £2	ON	ON	ON	OFF	OFF
9	40p	No Bonus			OFF	OFF	OFF	ON	OFF
10	40p	1.25 = 50p	3 = £1	6 = £2	ON	OFF	OFF	ON	OFF
11	50p	No Bonus			OFF	ON	OFF	ON	OFF
12	50p		3 = £1	6 = £2	ON	ON	OFF	ON	OFF
13	50p		2 = £1	5 = £2	OFF	OFF	ON	ON	OFF
14	60p	No Bonus			ON	OFF	ON	ON	OFF
15	60p		2 = £1	4 = £2	OFF	ON	ON	ON	OFF
16	80p	No Bonus			ON	ON	ON	ON	OFF
17	80p	1.25 = £1	2 = £1.50	2.5 = £2	OFF	OFF	OFF	OFF	ON
18	£1	No Bonus			ON	OFF	OFF	OFF	ON
19	£1		3 = £2		OFF	ON	OFF	OFF	ON
20	£1		2 = £2	5 = £4	ON	ON	OFF	OFF	ON
21	£1.50	No Bonus			OFF	OFF	ON	OFF	ON
22	£1.50		2 = £2		ON	OFF	ON	OFF	ON
23	£2	No Bonus			OFF	ON	ON	OFF	ON
24	£2			3 = £5	ON	ON	ON	OFF	ON
25	£3	No Bonus			OFF	OFF	OFF	ON	ON
26	£3			2 = £5	ON	OFF	OFF	ON	ON
27	£5	No Bonus			OFF	ON	OFF	ON	ON
28	£5			3 = £10	ON	ON	OFF	ON	ON
29	£7.50	No Bonus			OFF	OFF	ON	ON	ON
30	£7.50			2 = £10	ON	OFF	ON	ON	ON
31	£10	No Bonus			OFF	ON	ON	ON	ON
32	Free Play				ON	ON	ON	ON	ON

6.1.2. Price Of Play Settings Euro

	Price	Bonus			DIL Switch 1				
					Switch 1	Switch 2	Switch 3	Switch 4	Switch 5
1	10¢	No Bonus			OFF	OFF	OFF	OFF	OFF
2	10¢	6 = 50¢			ON	OFF	OFF	OFF	OFF
3	20¢	No Bonus			OFF	ON	OFF	OFF	OFF
4	20¢	3 = 50¢	6 = €1	12 = €2	ON	ON	OFF	OFF	OFF
5	30¢	No Bonus			OFF	OFF	ON	OFF	OFF
6	30¢	1.66 = 50¢	4 = €1	8 = €2	ON	OFF	ON	OFF	OFF
7	30¢	2 = 50¢	4 = €1		OFF	ON	ON	OFF	OFF
8	30¢	AMLD	3 = €1	6 = €2	ON	ON	ON	OFF	OFF
9	40¢	No Bonus			OFF	OFF	OFF	ON	OFF
10	40¢	1.25 = 50¢	3 = €1	6 = €2	ON	OFF	OFF	ON	OFF
11	50¢	No Bonus			OFF	ON	OFF	ON	OFF
12	50¢		3 = €1	6 = €2	ON	ON	OFF	ON	OFF
13	50¢		2 = €1	5 = €2	OFF	OFF	ON	ON	OFF
14	60¢	No Bonus			ON	OFF	ON	ON	OFF
15	60¢		2 = €1	4 = €2	OFF	ON	ON	ON	OFF
16	80¢	No Bonus			ON	ON	ON	ON	OFF
17	80¢	1.25 = £1	2 = €1.50	2.5 = €2	OFF	OFF	OFF	OFF	ON
18	€1	No Bonus			ON	OFF	OFF	OFF	ON
19	€1		3 = €2		OFF	ON	OFF	OFF	ON
20	€1		2 = €2	5 = €4	ON	ON	OFF	OFF	ON
21	€1.50	No Bonus			OFF	OFF	ON	OFF	ON
22	€1.50		2 = €2		ON	OFF	ON	OFF	ON
23	€2	No Bonus			OFF	ON	ON	OFF	ON
24	€2			3 = €5	ON	ON	ON	OFF	ON
25	€3	No Bonus			OFF	OFF	OFF	ON	ON
26	€3			2 = €5	ON	OFF	OFF	ON	ON
27	€5	No Bonus			OFF	ON	OFF	ON	ON
28	€5			3 = €10	ON	ON	OFF	ON	ON
29	€7.50	No Bonus			OFF	OFF	ON	ON	ON
30	€7.50			2 = €10	ON	OFF	ON	ON	ON
31	€10	No Bonus			OFF	ON	ON	ON	ON
32	Free Play				ON	ON	ON	ON	ON

6.1.3. Price Of Play Settings Austria-Czech-Denmark-Norway-Israel-France2

	Price	Bonus			Switch 1				
					Switch 1	Switch 2	Switch 3	Switch 4	Switch 5
1	1	No Bonus			OFF	OFF	OFF	OFF	OFF
2	1			11 = 10	ON	OFF	OFF	OFF	OFF
3	1		6 = 5		OFF	ON	OFF	OFF	OFF
4	2	No Bonus			ON	ON	OFF	OFF	OFF
5	2			6 = 10	OFF	OFF	ON	OFF	OFF
6	2		3 = 5		ON	OFF	ON	OFF	OFF
7	3	No Bonus			OFF	ON	ON	OFF	OFF
8	3			4 = 10	ON	ON	ON	OFF	OFF
9	3		2 = 5		OFF	OFF	OFF	ON	OFF
10	4	No Bonus			ON	OFF	OFF	ON	OFF
11	4		3 = 10		OFF	ON	OFF	ON	OFF
12	5	No Bonus			ON	ON	OFF	ON	OFF
13	5			3 = 10	OFF	OFF	ON	ON	OFF
14	6	No Bonus			ON	OFF	ON	ON	OFF
15	6			4 = 20	OFF	ON	ON	ON	OFF
16	8	No Bonus			ON	ON	ON	ON	OFF
17	10	No Bonus			OFF	OFF	OFF	OFF	ON
18	10			3 = 20	ON	OFF	OFF	OFF	ON
19	20	No Bonus			OFF	ON	OFF	OFF	ON
20	20			3 = 50	ON	ON	OFF	OFF	ON
21	30	No Bonus			OFF	OFF	ON	OFF	ON
22	30			2 = 50	ON	OFF	ON	OFF	ON
23	50	No Bonus			OFF	ON	ON	OFF	ON
24	50			3 = 100	ON	ON	ON	OFF	ON
32	Free Play				ON	ON	ON	ON	ON

7. DESIGN RELATED PARTS

For the Warning stickers refer to Section 1.

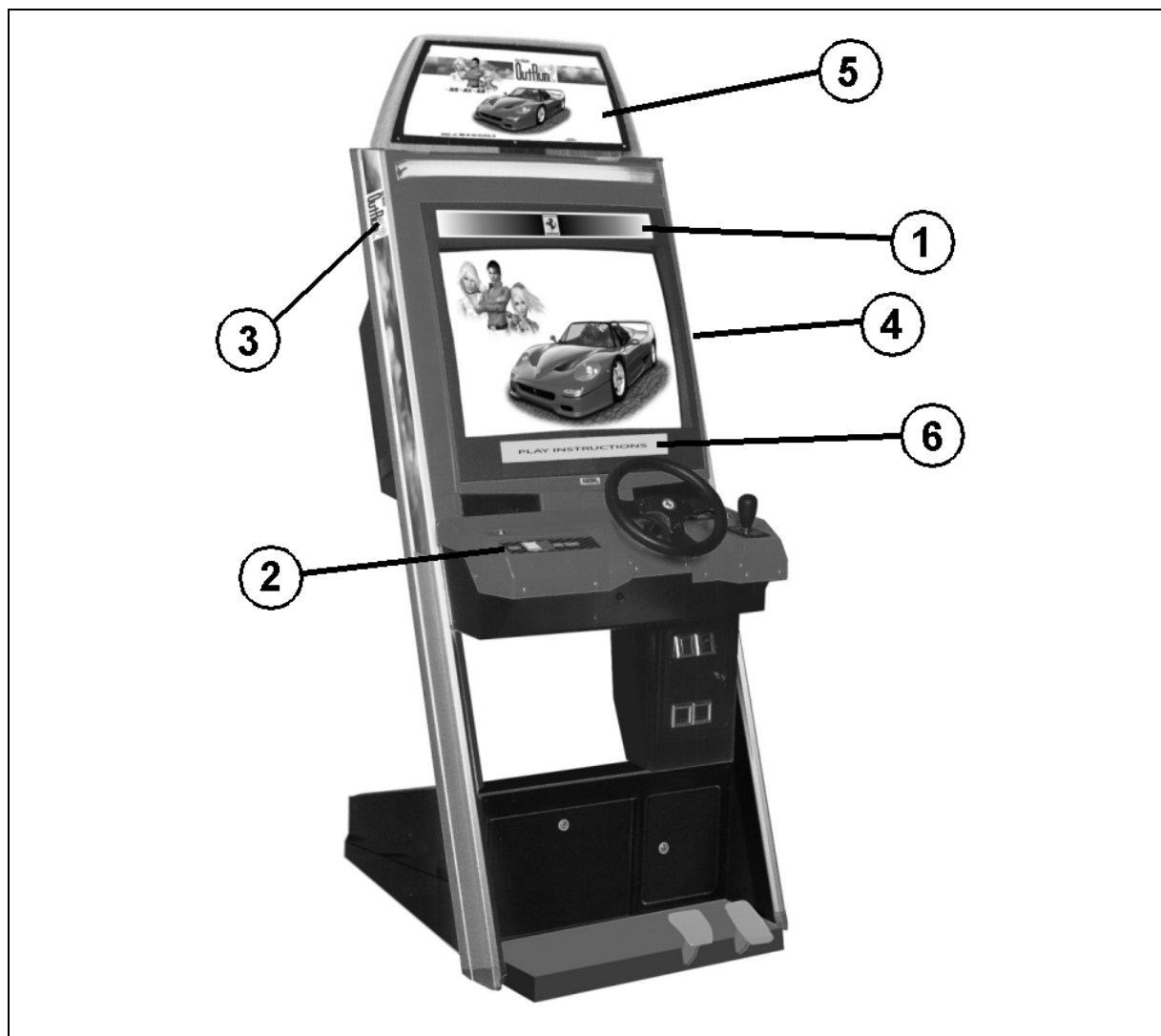

No.	PART No.	DESCRIPTION
1	ORT-1408UK	STICKER MASK UPPER
2	ORT-2003-BUK	STICKER START/VIEW ORT
3	ORT-1009UK	STICKER SIDE L
4	ORT-1010UK	STICKER SIDE R
5	ORT-0001UK	DISPLAY CARD ORT UR
6	ORT-0003UK	PLAY INSTR SH A MULTI

8. PARTS LIST

8.1. Assembly Structure

ORT-00002JUK ~ TOP ASSY OTRUN 2 U/R

ORT-1000JUK ~ ASSY UR CABI PENT

PTR-1110UK ~ ASSY FRAMEWORK BLACK NEW

PTR-1950UK ~ ASSY SFMD BLACK (FLAT DOOR)

NOA-1200UK ~ ASSY CRT COVER UK

ORT-1400JUK ~ ASSY FRONT PANEL PENT

CTA-1150UK ~ ASSY CC BOX WW

ORT-4000UK ~ ASSY ELEC

PTR-1750UK ~ ASSY SERVICE DOOR (BLACK)

ORT-4100UK ~ ASSY MAIN BD

ORT-1710UK ~ ASSY AC UNIT (BLACK PENT)

ORT-20002UK ~ ASSY CONTROL PANEL

CTA-4200UK ~ ASSY XFMR

ORT-6001UK ~ ASSY WIRE L

NOB-6001UK ~ ASSY WIRE L

CTA-6002UK ~ ASSY WIRE R

OTR-INST-JUR ~ ASSY INST KIT ORT PENT UR

ORT-1250UK ~ ASSY FLOOR SHORT

8.2. ORT-00002JUK TOP ASSY OTRUN 2 U/R

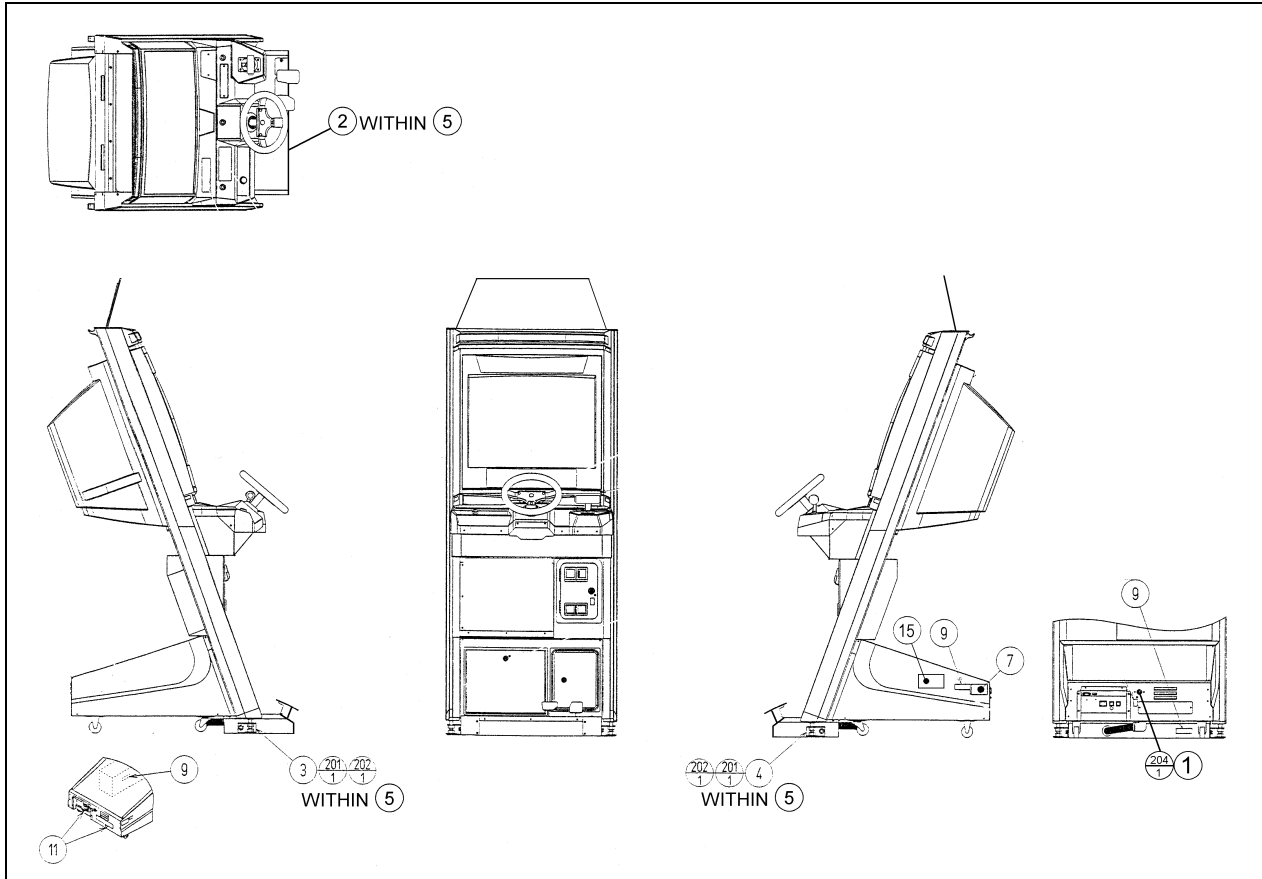

Item	Component No.	Description	Qty	Component Reference
1	ORT-1000JUK	ASSY UR CABI PENT	1	
5	OTR-INST-JUR	ASSY INST KIT ORT PENT UR	1	
7	421-7987-ORT-U	STICKER ELEC SPEC ORT NAOMI	1	
9	421-7988-91UK	STICKER SERIAL NUMBER UK	4	
11	421-7020UK	STICKER CAUTION FORK	2	
13	PK0203	PALLET CTA	1	
14	PK0345	SLEEVE ORT U/R	1	
15	LB1046	LABEL TESTED FOR ELEC. SAFETY	1	
16	PK0121	POLY COVER NAOMI UPRIGHT	1	
17	PK0345-LID	SLEEVE ORT U/R	1	
41	290241	C-BUFFER-MK2-UNIVERSAL	1	BANDING PROTECTION
204	008-T00430-0B	M4X30 TMP PRF TH BLK	1	REAR HATCH-1

8.3. ORT-1000JUK ASSY UR CABI PENT

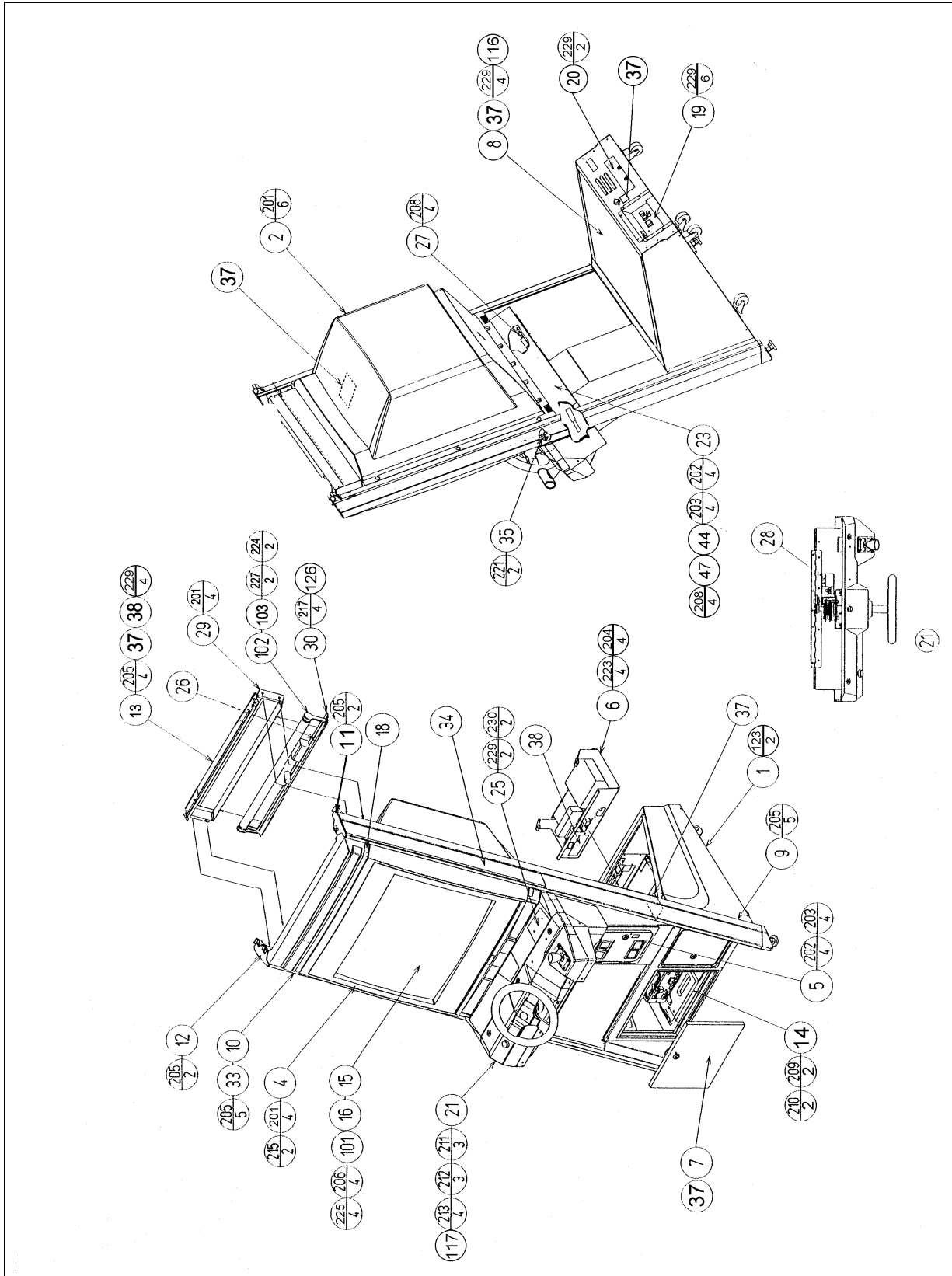

Item	Component Part	Description	QTY	Component Reference
1	PTR-1110UK	ASSY FRAMEWORK BLACK NEW	1	
2	NOA-1200UK	ASSY CRT COVER UK	1	ASSY CRT COVER UK
4	ORT-1400JUK	ASSY FRONT PANEL PENT	1	
5	CTA-1150UK	ASSY CC BOX WW	1	
6	ORT-4000UK	ASSY ELEC	1	
7	PTR-1750UK	ASSY SERVICE DOOR (BLACK)	1	
8	PTR-1801UK	REAR HATCH (BLACK)	1	
9	NOB-1001UK	FRAME COVER UR R	1	
10	NOB-1002UK	FRAME COVER UR L	1	
11	NOA-1003	ENDCAP R	1	
12	NOA-1004	ENDCAP L	1	
13	RTS-1010UK	BILLBOARD HOLDER	1	
14	ORT-4100UK	ASSY MAIN BD	1	
15	ORT-1111UK	SPACER FOR PENT MONITOR	4	
18	ORT-1006UK	SCR CAP	4	
19	ORT-1710UK	ASSY AC UNIT (BLACK PENT)	1	
20	RTS-1116UK	LID COMUNIPORT (BLACK)	1	
21	ORT-20002UK	ASSY CONTROL PANEL	1	
23	PTR-1001UK	CONTROL BOX	1	
25	ORT-1014UK	ENTRY COVER ORT	1	
26	421-7501-17	STICKER FL 20W	1	
27	837-13551-92	I/O CONTROL BD FOR JVS	1	
28	LB1103	STICKER CAUTION	1	INSIDE CONTROL PANEL (GEARS)
29	PTR-1005UK	REAR COVER UPPER (BLACK)	1	
30	NOA-1011	FL BRKT	1	
33	ORT-1009UK	STICKER SIDE L	1	
34	ORT-1010UK	STICKER SIDE R	1	
35	RCR-1019	CHAIN HOLDER B	1	
37	LB1102	STICKER DANGEROUS VOLTAGE	6	CRT,FL,HATCH,S/DOOR,CP, R LOCK
38	LB1104	STICKER CAUTION, HOT SURFACE	1	FL COVER
40	CTA-4200UK	ASSY XFMR	1	
41	CTA-2007UK	DRAINAGE GUTTER CE	1	-41
42	OS1177	TAPE D/S PVC 50mm X 50 M ROLL	0.5	-41
43	OS1239	SEALANT BLACK	0.1	-5
44	CTA-1011UK	FOAM STRIP 8 X 6mm	0.75	-23
47	ORT-1001-AUK	BRKT MTG MON REMOTE BD	1	
101	200-3129-P	ASSY CRT 29 31K PENT	1	
102	390-5695-40-CUK	FL TRAY 110V 40W (T12)	1	
103	390-5695-40-DUK	FL TUBE 40W 600L 1.5"DIA	1	

Cont.

Item	Component Part	Description	QTY	Component Reference
105	280-A01248-PM	ROUTER TWIST D12 SO4.8 PAN MED	9	
106	280-A02048-PM	ROUTER TWIST D20 SO4.8 PAN LG	7	
107	280-A02000-A	ROUTER TWIST D20 ADH	5	
111	280-N02310-0B	SLIT HARN WRAP 23mm DIA 1M BLK	0.2	WIRES THRU LH FRAME HOLE
113	OS1008	CABLE TIE, NYLON 150mm	2	
114	ORT-1117UK	WATER GUARD CE PENT	1	AROUND MONITOR CHASSIS
115	601-0460	CABLE TIE 100mm	10	
116	OS1230	FOAM STRIP 2mm X 10mm	1.18	2 X 0.59m TO (8)
117	OS1220	FOAM STRIP 8mmSQ ADHESIVE	1	(21)-1
123	280-K00600-0B	DRIVE FASTENER M6 BLACK	2	BASE BOX ABOVE COIN DOOR
126	290093	CMS)TAPE,FOAM(BLK)-3X6MMX25MTR	63	
201	008-T00625-0C	M6X25 TMP PRF TH CRM	14	(2)-6,(4)-4,(29)-4
202	030-000620-S	M6X20 BLT W/S PAS	8	(5)-4,(23)-4
203	068-651616	M6 WSHR 16OD FLT PAS	8	(5)-4,(23)-4
204	010-P00408	M4X8 S-TITE PAN PAS	4	(6)-4
205	008-T00412-0C	M4X12 TMP PRF TH CRM	14	(9)&(10)-5,(11)&(12)-2
206	050-F00600	M6 NUT FLG SER PAS	4	(101)-4
208	050-F00300	M3 NUT FLG SER PAS	8	(27)-4,(REMOTE BD)-2,(47)-2
209	032-000425	M4X25 W/BLT PAS	2	(14)-2
210	068-441616	M4 WSHR 16OD FLT PAS	2	(14)-2
211	008-B00825-0B	M8X25 TMP PRF BH BLK	3	(21)-3
212	068-852216-0B	M8 WSHR 22OD FLT BLK	3	(21)-3
213	050-F00500	M5 NUT FLG SER PAS	10	(21)-4,(EARTH)-6
215	000-P00416-W	M4X16 MSCR PAN W/FS PAS	2	(4)-2
217	000-P00408-W	M4X8 MSCR PAN W/FS PAS	7	(30)-4,(EARTHS)-3
221	000-P00512-W	M5X12 MSCR PAN W/FS PAS	2	(35)-2
223	060-F00400	M4 WSHR FORM A FLT PAS	4	(6)-4
224	050-F00400	M4 NUT FLG SER PAS	6	(102)-2,(5E)-1,(29E)-1,(31E)-1,(101)-1
225	068-652516	M6 WSHR 25OD FLT PAS	8	(40)-4,(101)-4
226	000-P00625	M6X25 MSCR PAN PAS	4	(40)-4
227	000-P00408	M4X8 MSCR PAN PAS	2	(103)-2
229	008-T00412-0B	M4X12 TMP PRF TH BLK	18	(8)&(13)-4,(19)-6,(20)&(25)-2
230	068-441616-0B	M4 WSHR 16OD FLT BLK	2	(25)-2
301	ORT-6001UK	ASSY WIRE L	1	
302	CTA-6002UK	ASSY WIRE R	1	
311	600-7159-070	WIRE HARN JVS PWR 070CM	1	
321	CTA-60062	WIRE HARN I/O BOARD PWR	1	
322	CTA-60066UK	WIRE HARN SW UNIT EXT	1	
323	CTA-60067UK	WIRE HARN VOL EXT	1	
324	CTA-60068UK	WIRE HARN SPEAKER	1	

Cont.

Item	Component Part	Description	QTY	Component Reference
326	NOB-60201UK	WIRE HARN FL NOB	1	
328	600-9070-45K	WIRE HARN EARTH 700mm M4/M5 K	1	BASE LID TO XFMR
330	600-9090-45K	WIRE HARN EARTH 900mm M4/M5 K	1	RH FRAME TOP TO FL BRKT
331	600-9010-44K	WIRE HARN EARTH 100mm M4/M4	1	FL BRKT TO B/BD HOLDER
332	600-9080-45K	WIRE HARN EARTH 800mm M4/M5 K	1	BASE TO RH FRAME (BOTTOM)
333	600-9045-45K	WIRE HARN EARTH 450mm M4/M5 K	2	MON. FRAME TO RH FRAME & COIN BOX TO I/O BASE

8.4. PTR-1110UK ASSY FRAMEWORK BLACK NEW

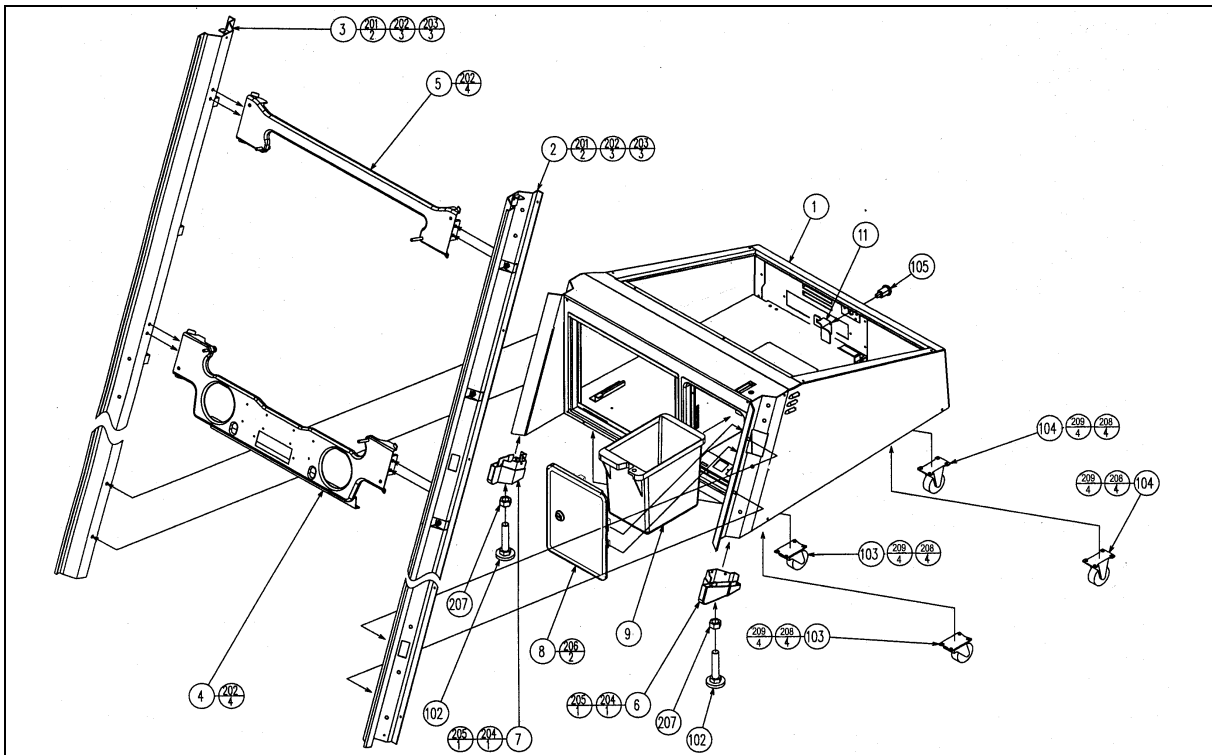

Item	Component Part	Description	QTY	Component Reference
1	PTR-1602UK	BASE BOX SFMD BLACK	1	
2	PTR-1101UK	MAIN FRAME U/R R (BLACK)	1	
3	PTR-1102UK	MAIN FRAME U/R L	1	
4	NOA-1111X	LOWER BEAM	1	
5	NOA-1112X	UPPER BEAM	1	
6	NOA-1113	HOOF R	1	
7	NOA-1114	HOOF L	1	
8	PTR-1950UK	ASSY SFMD BLACK (FLAT DOOR)	1	
9	253-5366	CASH BOX	1	
11	NOA-1115UK	TNG REAR HATCH	1	
102	601-5699X	LEG ADJUSTER BOLT M16x75 SEGA	2	
103	601-10461UK	CASTOR 50 SWIVEL	2	
104	601-10462UK	CASTOR 50 FIXED	2	
105	220-5575UK	LOCK	1	
201	050-F00600	M6 NUT FLG SER PAS	4	(2)-2,(3)-2
202	030-000620-S	M6X20 BLT W/S PAS	14	(2)-3,(3)-3,(4)-4,(5)-4
203	068-652016	M6 WSHR 20OD FLT PAS	6	(2)-3,(3)-3
204	050-F00500	M5 NUT FLG SER PAS	2	(6)-1,(7)-1
205	000-P00408-W	M4X8 MSCR PAN W/FS PAS	2	(6)-1,(7)-1
207	050-H01600	M16 NUT PAS	2	(102)-2
208	FAS-200004	M6X14 SKT CAP BLK	16	(103)-8,(104)-8
209	060-S00600-0B	M6 WSHR SPR BLK	16	(103)-8,(104)-8

8.5. PTR-1950UK ASSY SFMD BLACK (FLAT DOOR)

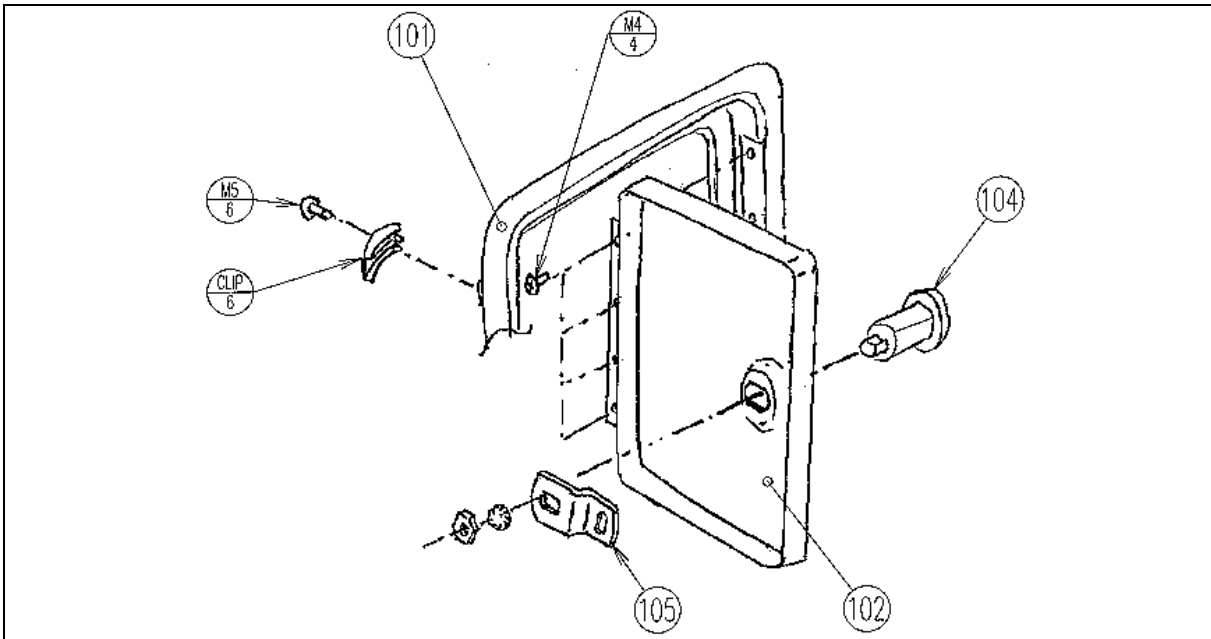

Item	Component Part	Description	QTY	Component Reference
101	220-5725-03	FRAME SINGLE MINI W/O PAINT	1	
102	220-5725-04	DOOR SINGLE MINI FLAT,NO PAINT	1	
104	220-5574UK	LOCK KEYED DIFFERENT	1	
105	PTR-1951UK	CAM CRANKED 6MM, LENGTH 34MM	1	
201	012-PB3506	N6X1/4" S/TAP PAN B	4	

8.6. NOA-1200UK ASSY CRT COVER UK

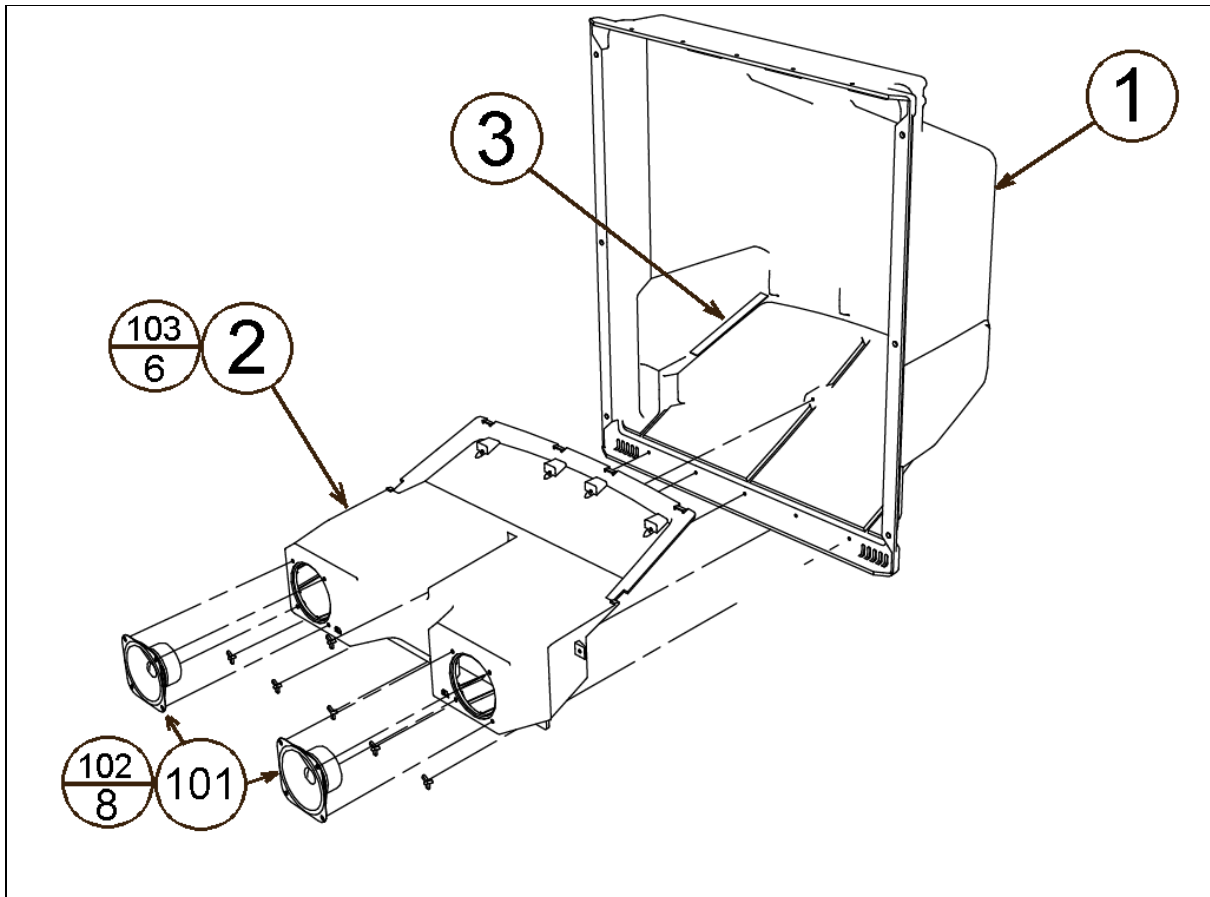

Item	Component Part	Description	Qty	Component Reference
1	NOA-1201UK	CRT COVER	1	
2	NOA-1202	SPEAKER BOX	1	
3	RND-0037	TAPE SPEAKER BOX 2 SIDED	0.38	(2)-0.19
101	130-5205	SPEAKER 40HM 10W 100 W/SHIELD	2	
102	000-P00410-W	M4X10 MSCR PAN W/FS PAS	8	(101)-8
103	340042	RIVET BULBEX 3/16 BF01-0630	6	(2)-6
301	NOA-60031	WIRE HARN SPEAKER L	1	
302	NOA-60032	WIRE HARN SPEAKER R	1	

8.7. ORT-1400JUK ASSY FRONT PANEL PENT

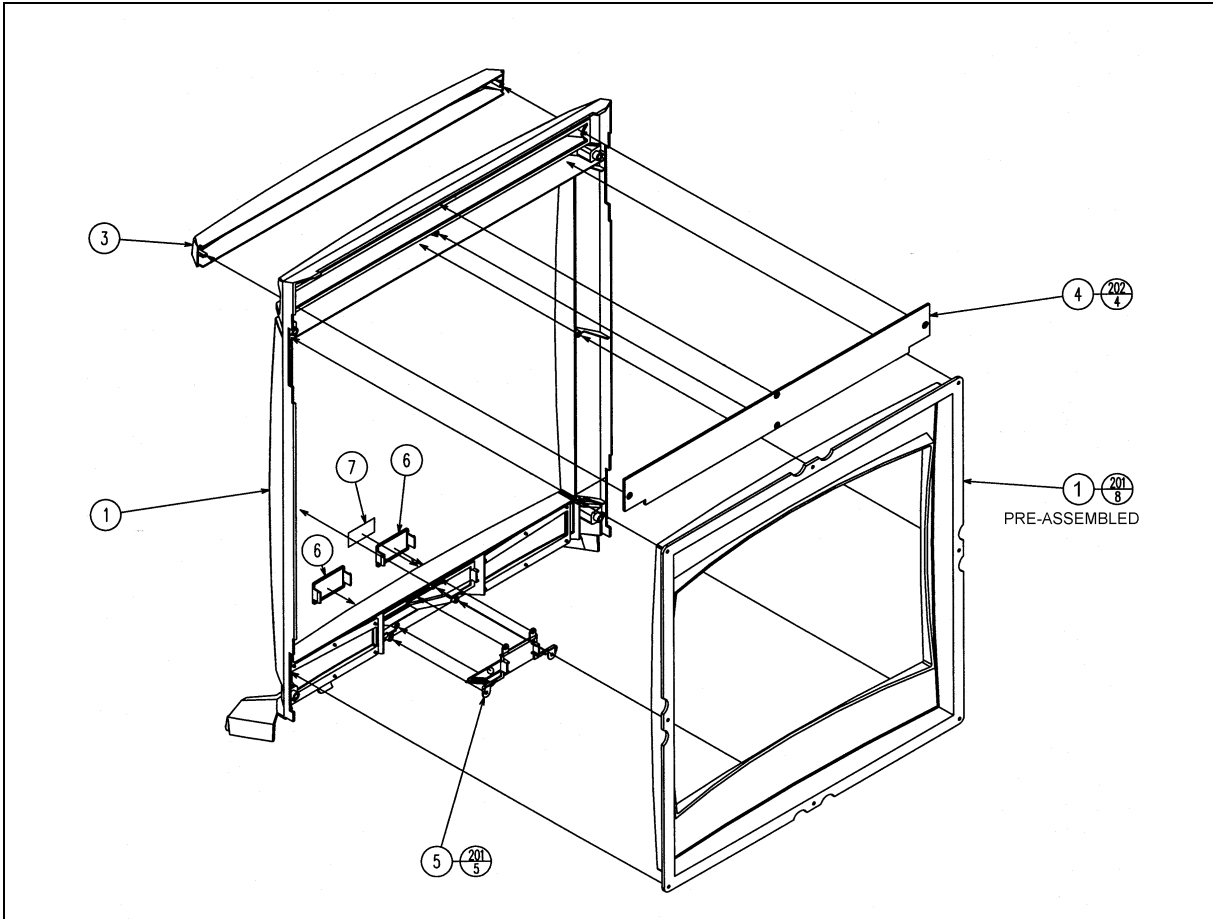

Item	Component Part	Description	QTY	Component Reference
1	ORT-1501UK	FRONT PANEL ORT	1	
1	NOA-1501	FRONT PANEL	1	
2	NOA-1502-02UK	INNER MASK PNF	1	
1	NOA-1502-02	INNER MASK NF	1	
3	NOA-1503	LIGHT COVER	1	
4	NOA-1504UK	PRISM PLATE	1	
5	ORT-1505UK	LID GCS	1	
1	NOA-1505	LID GCS	1	
6	ORT-1506UK	LID VMS	2	CLIP-IN
1	NOA-1506	LID VMS	1	
7	NOA-1507	EMBLEM NAOMI	1	
8	ORT-1408UK	STICKER MASK UPPER	1	
201	000-P00412-W	M4X12 MSCR PAN W/FS PAS	13	(2)-8,(5)-5
202	012-P03516	N6X5/8" S/TAP PAN PAS	4	(4)-4

8.8. CTA-1150UK ASSY CC BOX WW

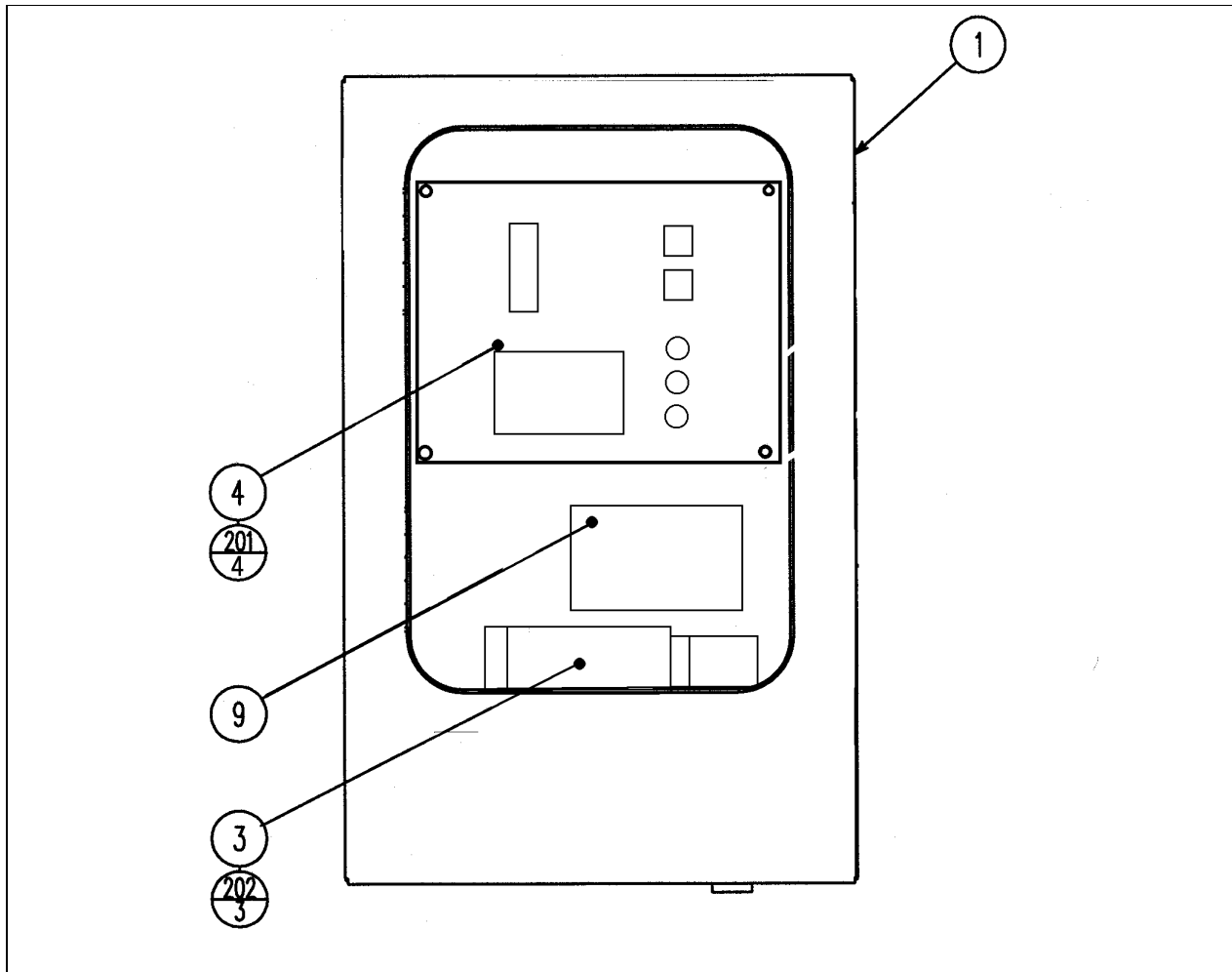

No.	PART NUMBER	QTY	DESCRIPTION	COMPONENT REFERENCE
1	CTA-1151UK	1	CC BOX WW	
3	CTA-1155UK	1	CHUTE UNIV	
4	VTS-STW-U	1	VTS BOARD UPRIGHT TYPE	
9	LB1103	1	STICKER CAUTION	
201	000-P00408-W	4	M4X8 MSCR POSI PAN W/FS	(4)-4
202	000-F00408	3	M4X8 MSCR POSI CSK BZP	(3)-3
301	CTA-60101UK	1	WIRE HARN VTS CTA	

8.9. ORT-4000UK ASSY ELEC

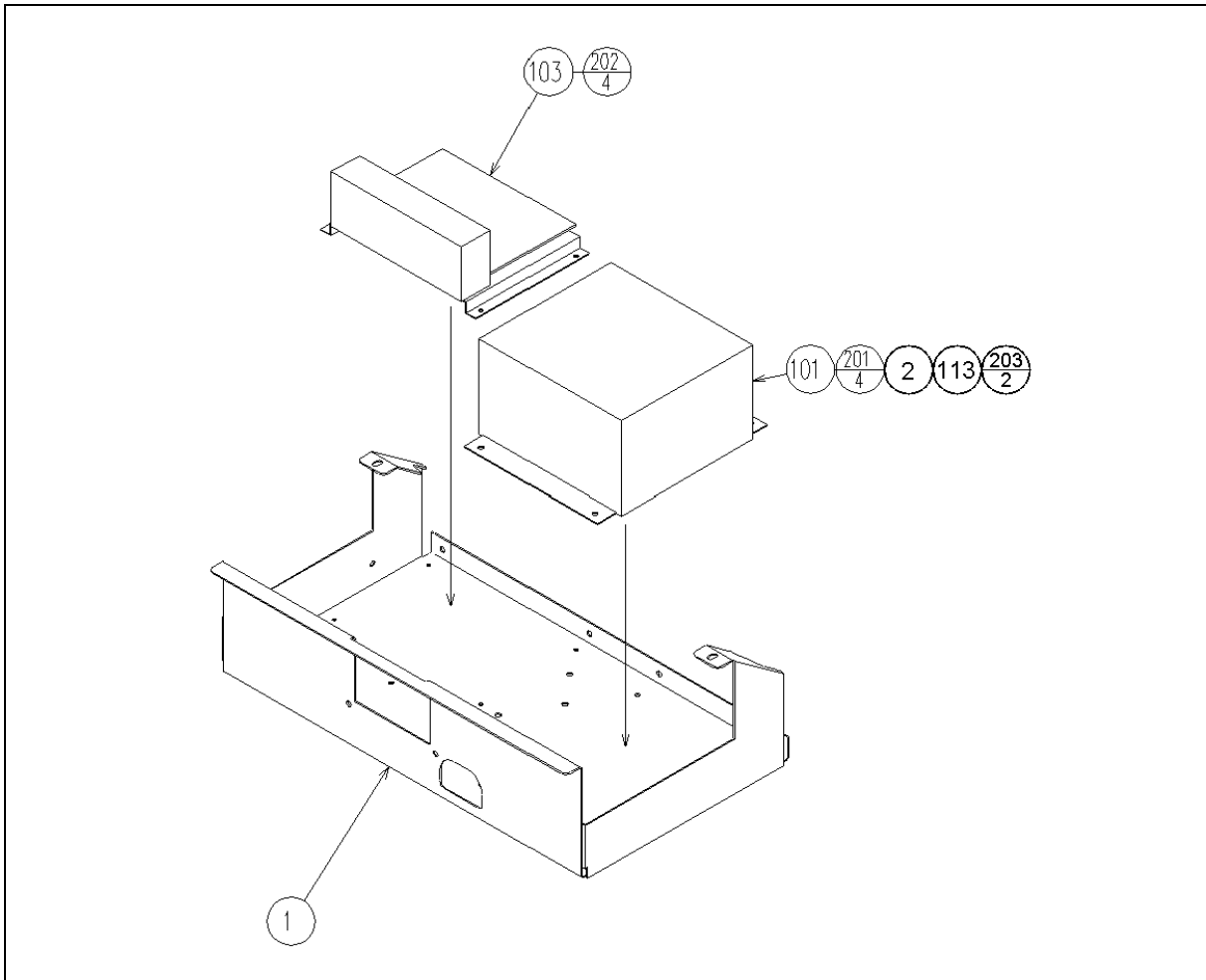

Item	Component Part	Description	QTY	Component Reference
1	CTH-4001	ELEC BASE SHORT	1	
2	NOM-4002	BRKT FOR PWR PROTECT UNIT	1	
101	400-5443	SW REGU FOR CHIHIRO	1	
103	838-13616	AUDIO POWER AMP 2CH	1	
107	280-A02048-PM	ROUTER TWIST D20 SO4.8 PAN LG	4	
108	601-6231-B095	EDGE TRIM NEW TYPE 0.91t	9,5	(1) BACK EDGE IN MIDDLE
110	280-A01248-PM	ROUTER TWIST D12 SO4.8 PAN MED	2	
111	280-A02000-A	ROUTER TWIST D20 ADH	1	
113	610-0674	POWER PROTECT UNIT FOR CHIHIRO	1	
201	010-P00408	M4X8 S-TITE PAN PAS	4	(101)-4
202	010-P00308	M3X8 S-TITE PAN PAS	4	(103)-4
203	000-P00408-W	M4X8 MSCR PAN W/FS PAS	2	(113)-2
303	NOB-60013UK	WIRE HARN SW REGU INT	1	
304	NOA-60014	WIRE HARN I/O BD PWR	1	
305	NOB-60202UK	WIRE HARN AUDIO POWER-IN	1	
306	600-7159-039	WIRE HARN JVS PWR 039CM	1	
307	CTH-60101UK	WH POWER PROTECT UNIT	1	

8.10. PTR-1750UK ASSY SERVICE DOOR (BLACK)

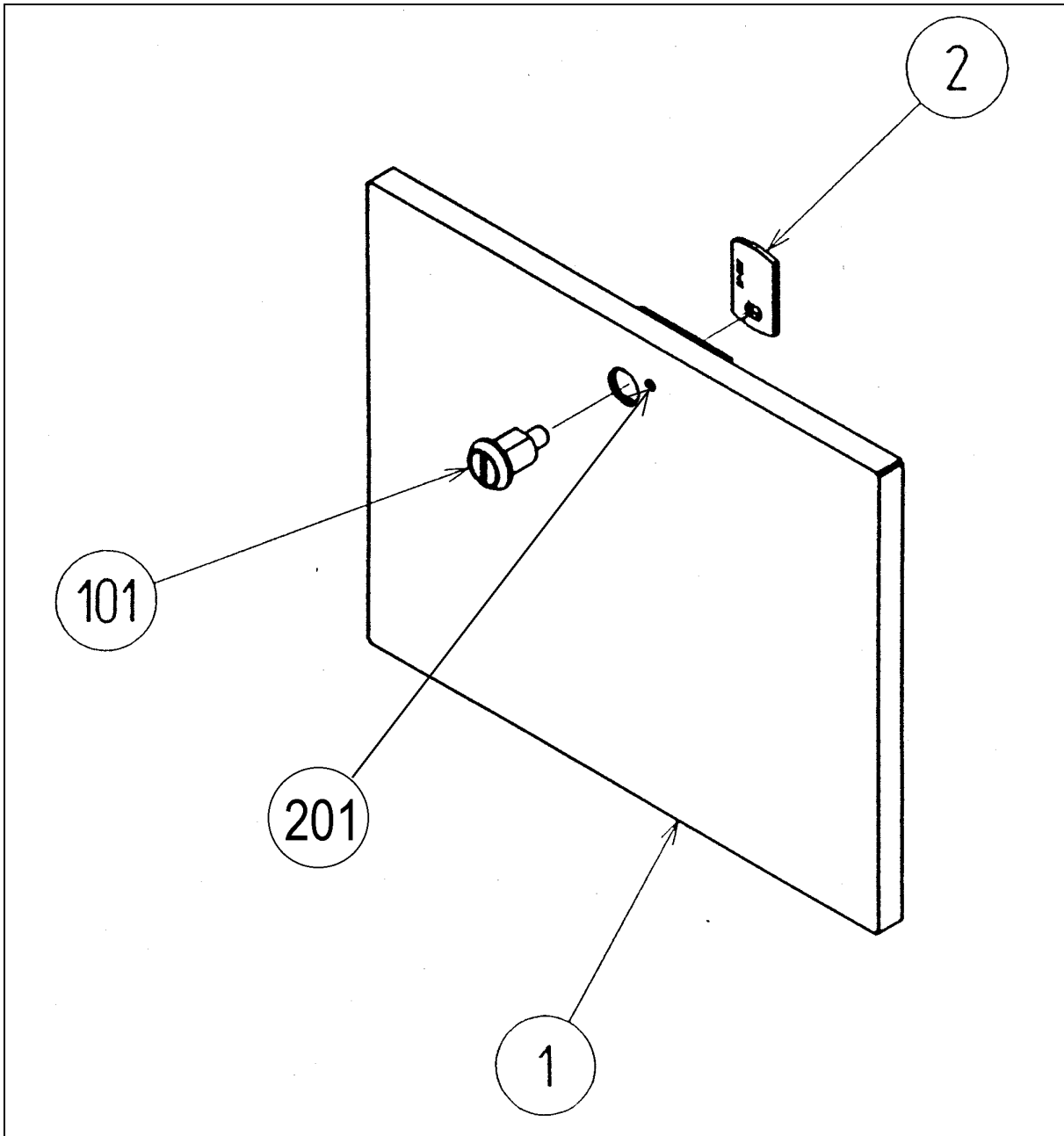

Item	Component Part	Description	QTY	Component Reference
1	PTR-1751UK	SERVICE DOOR (BLACK)	1	
2	DP-1167UK	TNG LKG UK	1	
101	220-5575UK	LOCK	1	
201	008-T00430-0C	M4X30 MSCR TMP PRF TH CR	1	INSERT HALF WAY SO TNG OPENS

8.11. ORT-4100UK ASSY MAIN BD

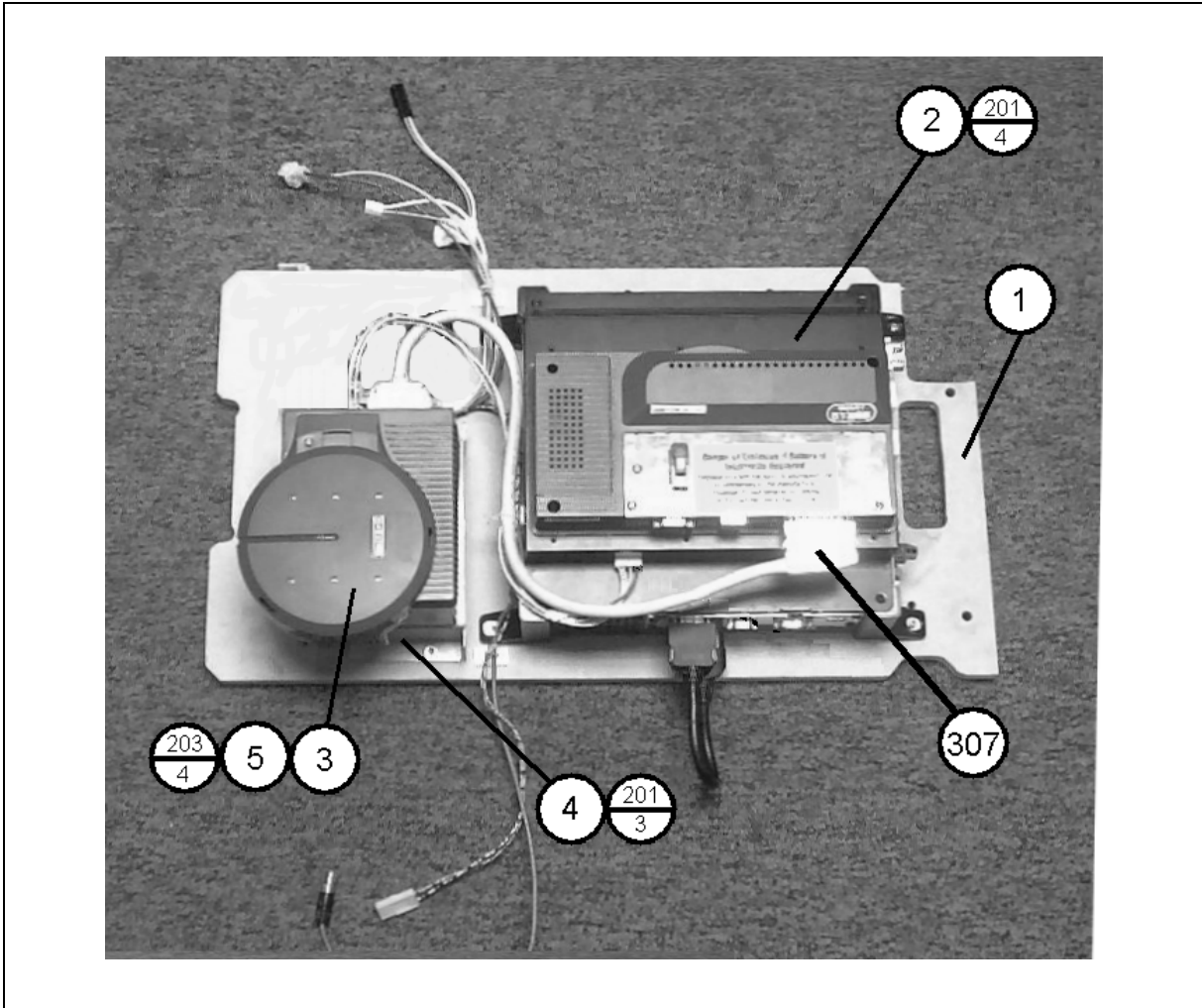

Item	Component Part	Description	QTY	Component Reference
1	CTH-4101UK	WOODEN BASE MAIN	1	
2	843-0005D-02	ASSY CASE BOX ORT EXP	1	
3	610-0617	GD-ROM DRIVE UNIT NAOMI	1	SHIP BOX WITH MACHINE
4	105-5435	GD DRIVE BRKT STD	1	
5	610-0652-0004	GD SOFT ORT	1	
103	LB1111	STICKER PLEASE RECYCLE	1	(2)-1
106	LB1101	STICKER WARNING BATTERY	1	(2)-1
107	280-A01264-WX	ROUTER TWIST D12 SO6.4 WOOD X	5	
201	000-P00416-W	M4X16 MSCR PAN W/FS PAS	7	(2)-4, (4)-3
203	012-P00410-F	N8X3/8" S/TAP FLG PAS	4	(3)-4
306	ORT-60100UK	WH POWER GD ROM	1	
307	600-7247-500	CABLE SCSI ST-L TYPE2 500MM	1	

8.12. ORT-1710UK ASSY AC UNIT (BLACK PENT)

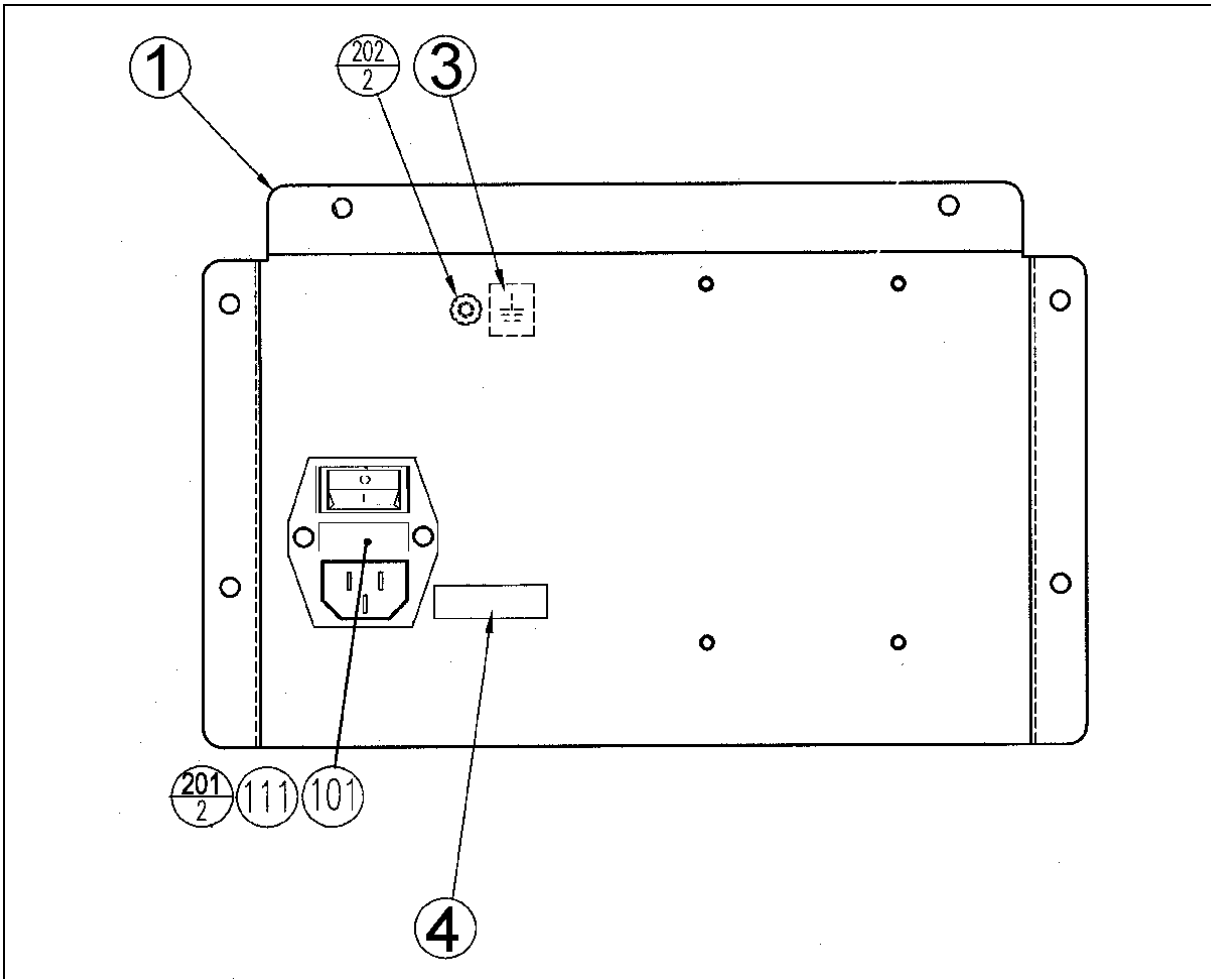

Item	Component Part	Description	QTY	Component Reference
1	RTS-1711UK	AC BRKT (BLACK)	1	
3	LB1096	STICKER PROTECTIVE EARTH	1	NXT TO EARTH STUD ON INSIDE
4	421-6595-5000-T	STICKER FUSE 5000mA TYPE T	1	NXT TO IEC INLET ON OUTSIDE
101	EP1381	FILTER IEC & SW 6A ROXBURGH	1	
111	514-5078-5000	FUSE 5X20 CERAMIC SB 5000mA	1	
202	050-F00400	M4 NUT FLG SER PAS	2	EARTH - 2
204	000-F00316	M3X16 MSCR CSK PAS	2	(101)-2
301	ORT-60004UK	WIRE HARN AC OUT	1	240V CHANGE
303	600-9030-45K	WIRE HARN EARTH 300mm M4/M5 K	1	AC BRKT TO XFMR
305	600-9025-44K	WIRE HARN EARTH 250mm M4/M4	1	AC BRKT TO BASE
306	600-9015-4FK	WIRE HARN EARTH 150MM	1	

8.13. ORT-20002UK ASSY CONTROL PANEL

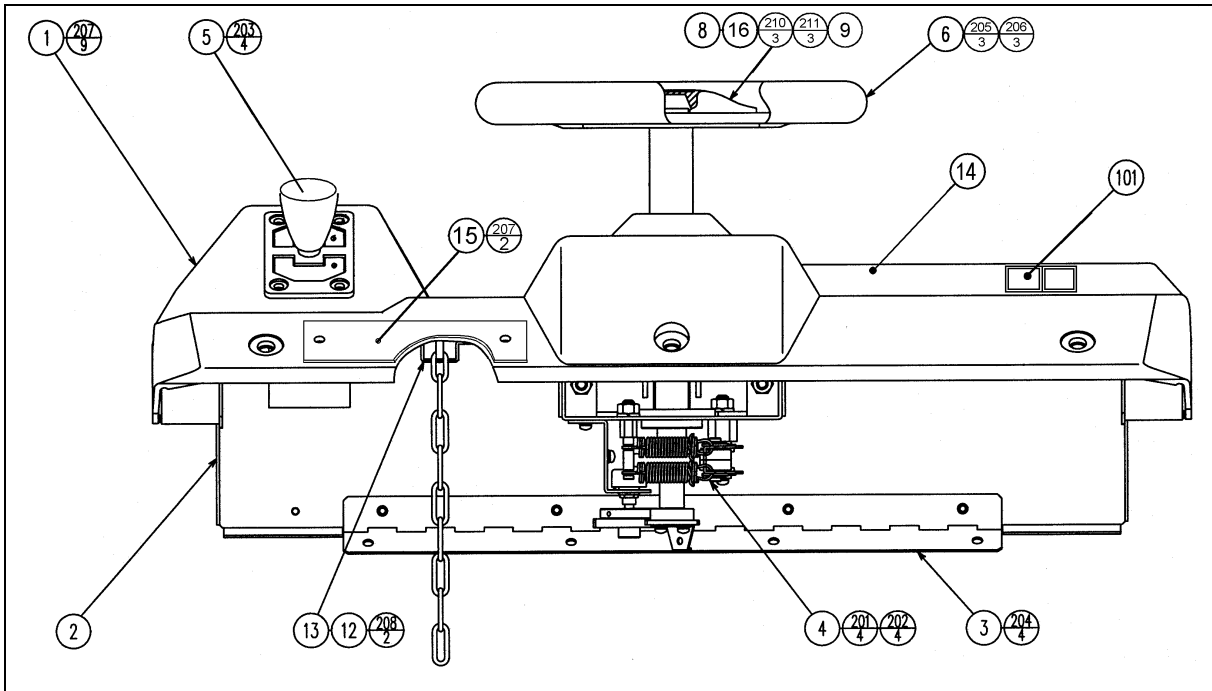

Item	Component Part	Description	QTY	Component Reference
1	ORT-2003-AUK	CONTROL PANEL BLANK	1	
2	CKT-2702UK	CONTROL PANEL BRKT	1	
3	CTA-2003	HINGE 456	1	
4	CTA-2100UK	ASSY HANDLE MECHA W/ BOSS HAPP	1	
5	610-0408-91	UP/DOWN SHIFTER AL	1	
6	JBA-2001UK	STEERING WHEEL HAPP	1	
8	ORT-2005UK	STEERING CENTRE	1	
9	FRI-2002-A	EMBLEM FERRARI	1	(8)-1
12	ORT-2006UK	CHAIN DRIVER UR	1	
13	RCR-1019	CHAIN HOLDER B	1	
14	ORT-2003-BUK	STICKER START/VIEW ORT	1	
15	MGL-2003	DENOMINATION PLATE	1	
16	JBA-2005UK	STEERING PLATE	1	MOUNT UNDER (8)
101	ORT-2010UK	SW PB DUAL RECTLP 57-0004-D505	1	YELLOW SW ON LEFT
103	280-A00900-A	ROUTER TWIST D9 ADH	6	
201	050-U00800	M8 NUT NYLOK PAS	4	(4)-4
202	060-F00800	M8 WSHR FORM A FLT PAS	4	(4)-4
203	008-T00512-0B	M5X12 TMP PRF TH BLK	4	(5)-4
204	050-F00500	M5 NUT FLG SER PAS	5	(3)-4,(EARTH)-1
205	FAS-200004	M6X14 SKT CAP BLK	3	(6)-3
206	060-S00600-0B	M6 WSHR SPR BLK	3	(6)-3
207	008-T00412-0B	M4X12 TMP PRF TH BLK	11	(1)-9, (15)-2

Cont.

Item	Component Part	Description	QTY	Component Reference
208	000-P00512-W	M5X12 MSCR PAN W/FS PAS	2	(13)-2
210	029-B00516-0B	M5X16 SKT BH BLK	3	(16)-3
211	FAS-290034	M5X15 LH CAP SCR STN	3	(8)-3
304	ORT-62014UK	WH CONTROL PANEL	1	
306	CTA-60065	WIRE HARN HANDLE EXT	1	
307	CTH-60008UK	WH MECHA PEDALS	1	
308	ORT-62100UK	WIRE HARN SW CONTROL	1	
309	ORT-62001UK	WH START VIEW BTN	1	
311	600-9010-55K	WIRE HARN EARTH 100mm M5/M5	1	CP BASE TO CTRL PANEL

8.14. CTA-4200UK ASSY XFMR

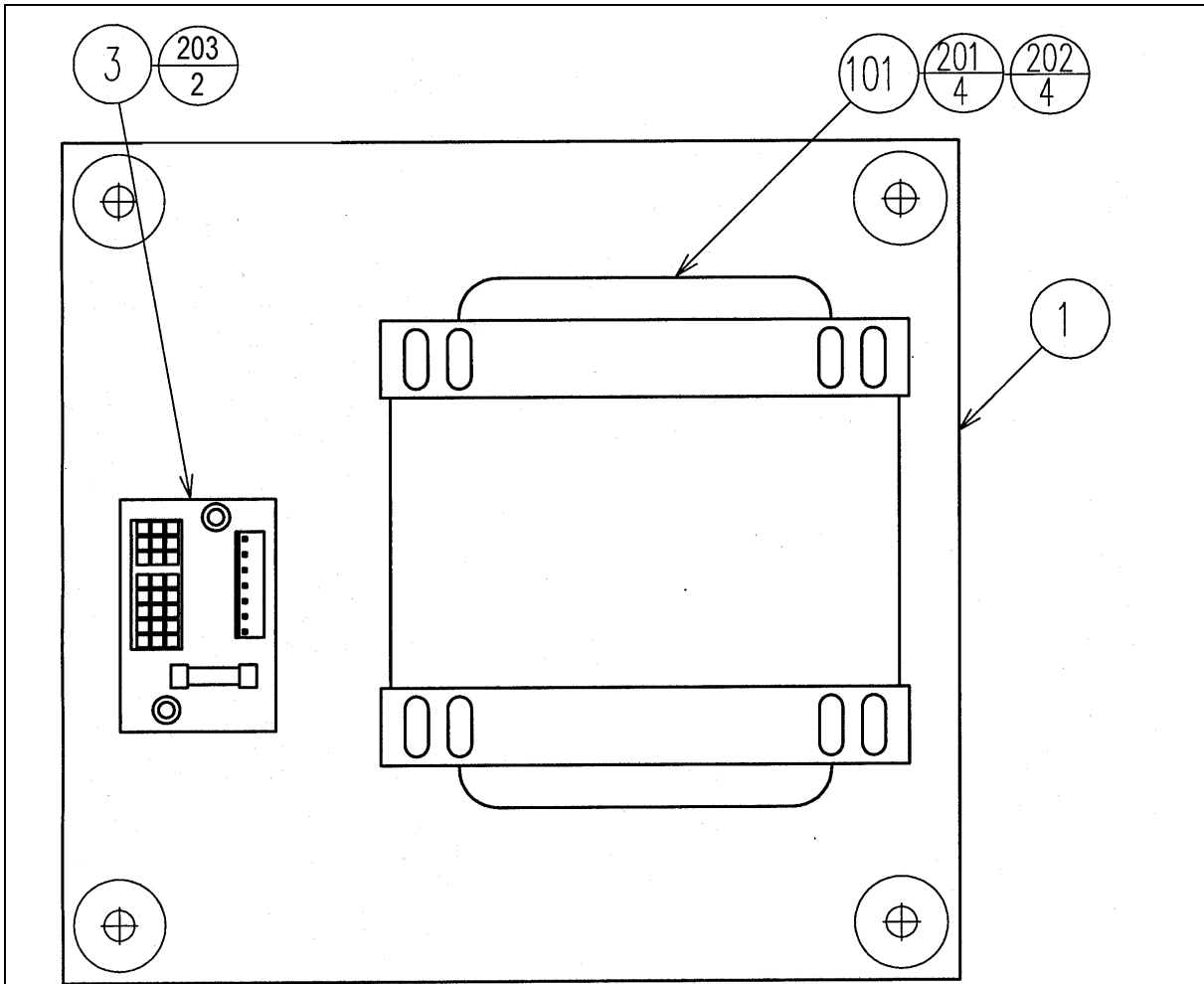

Item	Component Part	Description	QTY	Component Reference
1	CTA-4201UK	WOODEN BASE XFMR CTA	1	
3	838-11856CE-02	CONN BD W/FUSE 6.3A CE	1	
101	560-5422-01UK	XFMR CTA	1	
201	000-P00416-W	M4X16 MSCR POSI PAN W/FS	4	(101)-4
202	FX0301	M4 WSHR 16OD FLT BZP	4	(101)-4
203	FX0151	N4X1" S/TAP POSI PAN BZP	2	(3)-2
301	CTA-60013UK	WIRE HARN CONN BD OUT	1	

8.15. ORT-6001UK ASSY WIRE L

ASSEMBLY NOT SHOWN

Item	Component Part	Description	QTY	Component Reference
101	601-0460	CABLE TIE 100mm	10	
309	CTA-60002	WIRE HARN ACCEL BRAKE	1	
313	NOB-6001UK	ASSY WIRE L	1	

8.16. NOB-6001UK ASSY WIRE L

ASSEMBLY NOT SHOWN

Item	Component Part	Description	QTY	Component Reference
101	601-0460	CABLE TIE 100MM	12	
102	280-N01610	SLIT HARN WRAP 16MM DIA 1M BLK	0.4	
301	NOB-60043	WIRE HARN PWR I/O BD	1	
302	NOB-60044	WIRE HARN SOUND VOL	1	
303	NOB-60045	WIRE HARN SPEAKER L	1	
304	NOB-60046	WIRE HARN SPEAKER R	1	
305	600-7158-0100	CA AUDIO RCA TO RCA 2CH 100CM	1	
306	600-9075-45K	WIRE HARN EARTH 750MM M4/M5 U	1	
307	600-9055-45K	WIRE HARN EARTH 550MM M4/M5 K	1	
308	600-7141-250	CABLE JVS TYPE A-B 250CM	1	

8.17. CTA-6002UK ASSY WIRE R

ASSEMBLY NOT SHOWN

Item	Component Part	Description	QTY	Component Reference
101	601-0460	CABLE TIE 100mm	10	
301	CTA-60041UK	WIRE HARN AC EXT	1	
303	CTA-60001UK	WIRE HARN AC EXT BB	1	

8.18. OTR-INST-JUR ASSY INST KIT ORT PENT UR

ASSEMBLY NOT SHOWN

Item	Component Part	Description	QTY	Component Reference
1	NOA-1301X	BILLBOARD PLATE	1	
2	ORT-1250UK	ASSY FLOOR SHORT	1	
3	CTA-0001	JOINT BRKT L	1	
4	CTA-0002	JOINT BRKT R	1	
8	ORT-0001UK	DISPLAY CARD ORT UR	1	
9	NOA-1302UK	BILLBOARD SHEET	1	
14	ORT-0003UK	PLAY INSTR SH A MULTI	1	
18	420-3129-P	SERVICE MANUAL PENT 31K	1	
19	SAECE-XXX	DECLARATION OF CONFORMITY	1	DECLARATION OF CONFORMITY ORT
101	514-5078-5000	FUSE 5X20 CERAMIC SB 5000mA	1	
201	030-000820-SB	M8X20 BLT W/S BLK	2	(3)-1,(4)-1
202	068-852216-0B	M8 WSHR 22OD FLT BLK	2	(3)-1,(4)-1
203	008-T00412-0B	M4X12 TMP PRF TH BLK	5	(1)-2, (9)-3
402	420-6796-01UK	SERVICE MANUAL ORT UR	1	
403	420-6620UK	SERVICE MANUAL GD ROM SYSTEM	1	
406	OS1019	SELF SEAL BAG 9X12.3/4	1	
407	PK0346	INST KIT BOX ORT	1	
408	PK0061	BUBBLE WRAP LARGE 1.5M X 45M	0.025	
409	220-5484-H	VOL 5-K-OHM HAPP 50-8026-00	1	SPARE
411	540-0006-01	WRENCH M4 TMP PRF	1	
412	540-0007-01	WRENCH M5 TMP PRF	1	
413	540-0009-01	WRENCH M8 TMP PRF	1	
414	540-0015-01	WRENCH M6 TMP PRF	1	

8.19. ORT-1250UK ASSY FLOOR SHORT

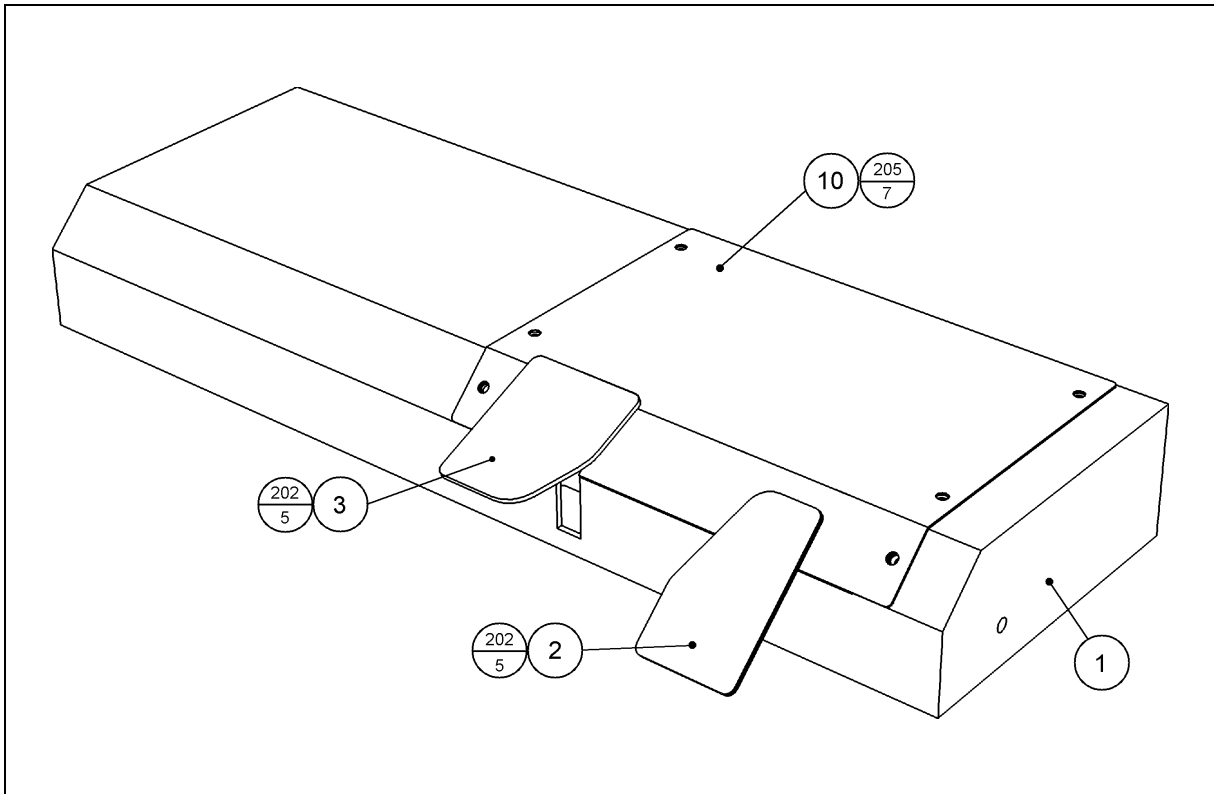

Item	Component Part	Description	QTY	Component Reference
1	ORT-1251UK	FLOOR BASE	1	
2	ORT-2600UK	ACCEL UNIT HAPP	1	
3	ORT-2650UK	BRAKE UNIT HAPP	1	
10	ORT-1508UK	FLOOR LID	1	
101	280-A01200-A	ROUTER TWIST D12 ADH	1	
202	050-F00600	M6 NUT FLG SER PAS	10	(2)-5,(3)-5
205	000-T00620-0C	M6X20 MSCR TH CRM	7	(10)-7
206	050-F00400	M4 NUT FLG SER PAS	1	(EARTH)-1
301	ORT-60030UK	WIRE HARN FLOOR TUBE	1	

9. APPENDIX A - ELECTRICAL SCHEMATIC

9.1. Wire Colours

THE WIRE COLOUR CODE IS AS FOLLOWS:

A	PINK
B	SKY BLUE
C	BROWN
D	PURPLE
E	LIGHT GREEN

Wires other than those of any of the colours listed above will be displayed by 2 alphanumeric characters:

1	RED
2	BLUE
3	YELLOW
4	GREEN
5	WHITE
7	ORANGE
8	BLACK
9	GREY

If the right hand side numeral of the code is 0, then the wire will be of a single colour shown by the left hand side numeral (see the list above).

Note 1: If the right hand side alphanumeric is not 0, that particular wire has a spiral colour code. The left hand side character shows the base colour and the right hand side one, the spiral colour.

[Example] 51----- WHITE/RED = WHITE wire with RED stripes

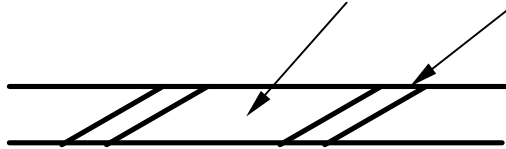

Note 2: The character following the wire colour code indicates the size of the wire.

K:	AWG18, UL1015
L:	AWG20, UL1007
None	AWG22, UL1007

9.2. Electrical Schematic

The following pages contain the electrical schematics for this machine.

SCHEMATIC 1 HERE

SCHEMATIC 2HERE

SEGA AMUSEMENTS EUROPE LTD./ SEGA SERVICE CENTRE

Suite 3a
Oaks House
12 - 22 West Street
Epsom
Surrey
United Kingdom
KT18 7RG

Telephone: +44 (0) 1372 731820

Fax: +44 (0) 1372 731849

SEGA[®]



ã SEGA 2002