



Installation & Owner's Manual

**FOR TECHNICAL ASSISTANCE:
CONTACT YOUR LOCAL DISTRIBUTOR**

For a list of distributors, visit the Merit Industries, Inc. Web site

www.meritind.com



merit industries, inc.

PM0519-03

Table of Contents

<p>Site Preparation p. 1</p> <p>Setting up your Megatouch Game p. 1</p> <p>Game Description p. 1-2</p> <p style="padding-left: 20px;">CPU Section p. 2</p> <p style="padding-left: 20px;">Hopper/Overflow Bucket p. 2</p> <p style="padding-left: 20px;">Security Key p. 2</p> <p>General Care and Maintenance p. 2-4</p> <p style="padding-left: 20px;">Screen Calibration p. 2</p> <p style="padding-left: 20px;">Monitor Color Adjustment Procedures p. 3</p> <p style="padding-left: 20px;">General Circuit Board Handling Information p. 3</p> <p style="padding-left: 20px;">Cleaning the Cabinet p. 4</p> <p style="padding-left: 20px;">Cleaning the Touchscreen Monitor p. 4</p> <p style="padding-left: 20px;">Cleaning the Fans and Vents p. 4</p> <p style="padding-left: 20px;">Watchdog Timer p. 4</p> <p>Megatouch FORCE Software</p> <p>Main Menu p. 5-6</p> <p>Amusement Games Menu p. 7</p> <p>Amusement Hi Scores Menu p. 7</p> <p>Books Menu p. 8-9</p> <p style="padding-left: 20px;">Cash Settlement Screens p. 9</p> <p>System Menu p. 10</p>	<p>Diagnostics Menu p. 11</p> <p>Presentation Menu p. 12</p> <p style="padding-left: 20px;">Operator Ad Screens p. 12</p> <p>Promotion Menu p. 12-13</p> <p style="padding-left: 20px;">My Merit p. 12-13</p> <p style="padding-left: 20px;">Merit Money p. 13</p> <p style="padding-left: 20px;">Promo Credits p. 13</p> <p>S.W.P. Menu p. 14-16</p> <p style="padding-left: 20px;">Game Setup p. 14</p> <p style="padding-left: 20px;">Statistics p. 14</p> <p style="padding-left: 20px;">Hopper Setup/Refill p. 15-16</p> <p style="padding-left: 20px;">Set Security PIN p. 16</p> <p>Mode Configuration Menu p. 16</p> <p>Megatouch FORCE Hardware</p> <p>DIP Switch Settings in FORCE Games p. 17</p> <p>Troubleshooting p. 18-20</p> <p>Parts List and Illustrations</p> <p style="padding-left: 20px;">Game Illustration p. 21-24</p> <p style="padding-left: 20px;">Replacement Parts List p. 25</p> <p style="padding-left: 20px;">Connection Diagrams p. 26</p> <p>TournaCHAMP p. 27-37</p> <p>Warranty and Software License Agreements</p> <p style="padding-left: 20px;">Warranty p. 38</p> <p style="padding-left: 20px;">Software License Agreements p. 39-44</p>
--	--

© 2005 Merit Industries, Inc.

Championship Edition, Money Shoot, and TournaCHAMP are registered trademarks of Merit Industries, Inc.

Reproduction of this manual, in any form or by any means, is strictly forbidden without the written permission of Merit Industries, Inc.

Site Preparation

In determining the location for your Megatouch video game, consideration must be given to a suitable, grounded electrical outlet. Since the game is a computerized device, it should have a separate circuit if at all possible. If a separate circuit is not available, care should be taken to provide a clean and constant voltage. As a basic guideline, never connect the unit to a circuit that also supplies power to freezers, coolers or other high power consuming and electrical noise generating equipment. Place the game in a location where nothing will interfere with proper ventilation. The game should not be exposed to any dripping or splashing liquids.

NOTE: After turning off the unit, wait 60 seconds before turning the game back on. This will allow the game to properly reset.

Setting up your Megatouch Game

1. Remove the game from the carton.
2. Open the additional box and use the instructions provided to attach the drink arms to the game.
3. Attach the power cord to the back of the game near the ON/OFF switch. Plug the game into a standard AC outlet.
4. Turn the power switch at the back of the game to ON and wait for it to go through its boot-up sequence. At the completion of the boot-up sequence, the game will display the Player Menu.
5. The machine has been preset at the factory and therefore should not need to be adjusted; however, it is recommended that the screen be calibrated (see **Screen Calibration**) and the coin or bill acceptor(s) be tested.
6. There are many custom settings available for the game. To customize the settings, follow the instructions beginning with the Main Menu section in this manual.

Game Description

The game is housed in a 61.25" upright cabinet. It should be located on a sturdy, level surface. The bottom of the cabinet has four leg levellers to make any necessary adjustments. When the game is properly adjusted, it should remain stable.

There are 4 key-locked compartments: the top bezel, monitor bezel, bottom door, and the cash box door. An additional keyhole is located on the right side of the game for the Refill Key. See the **Hopper Refill** section of this manual for more information.

Three modes are available for gameplay: Amusement, Money Shoot/Skill With Prize (S.W.P.), and Tournament (TournaCHAMP and Championship Edition). The default setting is S.W.P. only. TournaCHAMP play requires a modem. Championship Edition is available with the purchase of an additional kit (part number KUV-113-003-01).

The SETUP and CALIBRATE buttons are located on the monitor control board above the LCD touchscreen (see Figure 1). To access the monitor control board, unlock the left and right locks on the top bezel. Lift the bezel. The screen will go blank. Press the SETUP button and a keypad will display on-screen. Enter your PIN code (default is **4777**) to load the Main Menu Screen or turn the Refill Key. An incorrect PIN will clear the keypad. After 3 incorrect attempts, entry to SETUP is not permitted. Close and open the top bezel to reset the keypad.

See **General Care and Maintenance** for calibration instructions.

NOTE: To close the bezel, lift it, then push down on the yellow rubber bracket covers to move the brackets from the locking channel. Lower the bezel to close. Make sure all doors are locked after closing the doors.

CPU Section

The CPU section is accessible by unlocking the bottom door of the game. This section houses an electronics box which contains the motherboard, I/O board, power supply, hard drive, and the main harness.

The Cash In, Cash Out, Hopper Refill, and Prize Pool hard meters are attached to the electronics box. See Figure 23. Each meter is labeled.

Coin Mech/Bill Acceptor and Cash Box

The coin mech and/or bill acceptor are accessible by opening the monitor bezel of the cabinet (see Figure 21). The coin box and the hopper overflow bucket are located within the metal cash box door. This door is key-locked for security.

Hopper

The hopper is located in the monitor bezel compartment and dispenses coin prize payouts. See the **Hopper Setup** section of this manual for further instructions.

Security Keys

Money Shoot is equipped with two security keys. Key 1 is located on the monitor control board. See Figures 1 and 22. Key 2 is located on the I/O board and is permanently installed in the game. See Figure 23.

Key 2 requires recharging after 40,000 General Purpose Plays (sum of all Amusement, S.W.P. and Tournament credits) are used. Once the number of General Purpose Plays is less than 3,000, the message "**Warning X credits remaining, please recharge key,**" will display in the SETUP Menu and on the Refill screen.

To order Recharge Key kits (part number KUV-113-002-01), contact your authorized Merit Distributor.

If the number of General Purpose Plays decreases to 0 without being recharged, S.W.P. mode will automatically deactivate and the game will begin to use its 1,000 Emergency Reserve credits. All Amusement and Tournament games will continue to be available. Once the 1,000 Emergency Reserve credits are used, the game will limit play to 9 pre-selected Amusement games. These games cannot be changed by the operator. The game will not regain normal functionality until Key 2 is recharged.

General Care and Maintenance

NOTE: THIS GAME MUST ONLY BE SERVICED BY QUALIFIED SERVICE PERSONNEL.

CAUTION: THERE ARE HIGH VOLTAGE PARTS IN THIS GAME. BE CAREFUL WHEN SERVICING THE INSIDE OF THE GAME. GAME SHOULD ALWAYS BE UNPLUGGED BEFORE SERVICING.

Screen Calibration

- Find the **CALIBRATE** button located on the monitor control board and press it to enter the screen calibration mode.
- Touch the center of the first cross that appears on the screen. Once you release your finger, a second cross will appear.

NOTE: You must hold your finger on the cross for approximately 2 seconds for the calibration to be recognized.

- Touch the center of the second cross that appears on the screen.
- Once the second cross is touched and released, another cross will appear on the screen. To test the calibration of the screen, touch the cross with your finger and slowly drag your finger around the screen. The cross should follow your movement.
- Touch the **EXIT** button.

Monitor Adjustment Procedure

The vertical/horizontal controls and brightness/contrast controls are located on the monitor control board. See Figure 1.

Unlock and open the top bezel so the control board is accessible while viewing the monitor. Pressing the button labeled **Menu** on the control board will show the on-screen display on the monitor. Adjust the monitor controls until the screens look as suggested in the following steps. When finished, close and lock the bezel.

1. Set the game to the Quik Match game screen.
2. Adjust the vertical and horizontal size and vertical and horizontal position to make sure that the game screen fills the monitor screen and that the game screen is centered.
3. Adjust the brightness and contrast controls until the red tiles are a rich red and the background is black. The numbers on the tiles should be bright white. (Adjusting the brightness and contrast can also correct for a lack of sharpness.)

General Circuit Board Handling Information

Before handling any boards, observing the following procedures to prevent electrostatic discharge:

1. Store the boards in the anti-static bags in which they are shipped.
 2. Remove any static charge from your body before handling the boards.
 3. Use a ground strap when handling the boards.
- When plugging in connectors to the board, make sure the connector is inserted straight onto the header and that the connector covers all header pins.
 - Do not connect any peripheral device to the board, if the power is still connected to the peripheral or if power is already applied to the board.

CAUTION: Be extremely careful when replacing the lithium battery on the motherboard. There is a danger of explosion if the battery on the motherboard is incorrectly replaced. Only replace the battery with the same type recommended by the manufacturer. Dispose of used batteries according to the manufacturer's instructions.

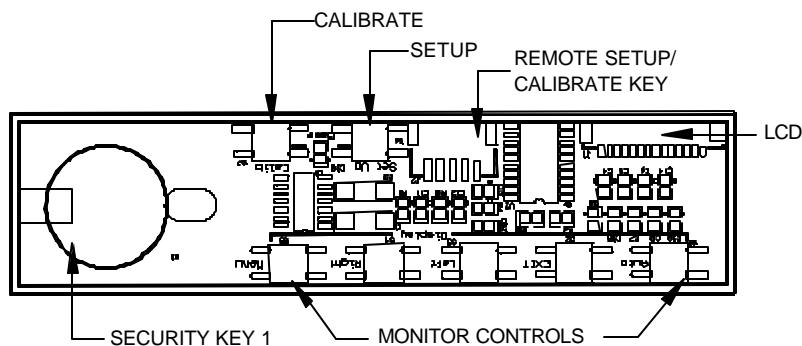

FIGURE 1 - MONITOR CONTROL BOARD

Cleaning the Cabinet

- The cabinet should be cleaned with a damp cloth and mild detergent. Always apply the cleaner to the cloth and not directly on the game. Liquids could enter the cabinet and damage electronics inside.

Cleaning the Touchscreen Monitor

- The touchscreen glass should be cleaned with a damp cloth and isopropyl alcohol or a *non-ammonia* cleanser. *Do not use any abrasive or vinegar-based cleansers, as they will damage the touchscreen glass.*

NOTE: DO NOT USE ANY ABRASIVE SOLVENTS, ACID OR VINEGAR-BASED CLEANSERS ON THE MONITOR OR SIDE DECALS. OVER TIME, SUCH CLEANSERS COULD HARM THE TOUCHSCREEN AND ERASE THE DECALS. BE CAREFUL NOT TO USE COMMERCIAL CLEANERS CONTAINING ANY OF THESE SUBSTANCES.

Cleaning the Fans and Vents

- The fans and vents should be cleaned of any dust on a regular basis to ensure proper ventilation of the game.
- To ensure proper operation of the game, it is important that all fans are operating correctly and that the airflow is unobstructed. Make sure nothing is placed inside the cabinet or next to the fan vents that would inhibit the flow of air. Also, if any fans are not operating, it is important that they be replaced.

Watchdog Timer

This game has been equipped with a feature that allows it to automatically reboot if it encounters a problem. When the watchdog timer is enabled, it will reboot the machine within 2 minutes after a failure, allowing the game to automatically reset itself if a problem arises without needing a technician present.

If you want to disable the watchdog timer, set DIP switch 3 on the I/O board to the open position and reboot the game.

NOTE: After turning the unit off, wait 60 seconds before restarting the unit. This will ensure the game properly resets.

Main Menu

The Main Menu can be accessed by pressing the **SETUP** button inside the game. Use the Main Menu to set up all game software options.

NOTE: For help with the Options in any menu section, touch the green “?” buttons to bring up a help screen.



FIGURE 2 - MAIN MENU

A summary of the Main Menu functions appears in the following table. For more detail, see the corresponding sections of the manual.

Main Menu	Available Options	Information
CREDITS	<ul style="list-style-type: none"> Options Clear Credits Free Credits 	Choose if game prices are viewed as currency or credits. Default view is currency. Add or clear free credits.
AMUSEMENT GAMES	<ul style="list-style-type: none"> Game Setup Options 	Edit the game list (choose which games are available and in what category they appear on the Category menu), change prices, and select game options.
AMUSEMENT HI SCORES	<ul style="list-style-type: none"> View/Clear Hi Scores Options 	View and edit hi scores. Set scoring options.
BOOKS	<ul style="list-style-type: none"> Books Display Cash Settlement Setup Cash Settlement Collection 	The Books Screens display current and lifetime credits information as well as calculate the location and operator fees.
SYSTEM	<ul style="list-style-type: none"> Set Time Security Set Game Serial Number Volume Control Set 6 Star PIN Data Transfer Options 	Set the game clock, security PIN and protected features, serial number, 6 star PIN, game volume, and system options such as language control and theft deterrent. Also use this menu to transfer books data with a USB Pen.

Main Menu	Available Options	Information
DIAGNOSTICS	<ul style="list-style-type: none"> • Video Test • I/O Test • Touchscreen Calibration • Touchscreen Test • View System Log • Checksum Test • System Info 	<ul style="list-style-type: none"> • Enters the Video Test to display the test screens. Touch the screen to cycle through test. • Tests the function of the I/O board, DIP switches, meters, and lockout. • Allows the operator to calibrate the touchscreen. Follow the instructions on the screen. • Checks touchscreen calibration. Touch the cross on the screen to make sure it is accurately following your movement. • Displays operations performed by the game. • Checks the hard drive for missing or corrupted files. • Details the various hardware components in the game.
TOURNACHAMP	<ul style="list-style-type: none"> • TournaCHAMP setup screens 	Enters the TournaCHAMP Setup Screen if the game is registered for TournaCHAMP play. See the TournaCHAMP section of this manual for more information.
TOURNAMENT	<ul style="list-style-type: none"> • Championship setup screens 	Enters the Tournament Menu Screen. Enabling Championship Mode requires the purchase of a separate kit.
PRESENTATION	<ul style="list-style-type: none"> • Operator Ad Screens 	Allows the operator to create ad screens and upload custom screens from a personal computer.
PROMOTION	<ul style="list-style-type: none"> • My Merit • Options 	<ul style="list-style-type: none"> • Enables a feature permitting players to create custom accounts. Also displays individual player data and allows the operator to back up or restore My Merit data. • Enable My Merit, Merit Money, and Promo Credits. These buttons will appear in the Promotion Menu when selected.
SKILL WITH PRIZE (S.W.P.)	<ul style="list-style-type: none"> • Games • Statistics • Hopper Setup • Set Security PIN • Recharge Key 	In these screens, edit the game list, and view statistics for all games. Change hopper settings and security PIN. You can also view available gameplays and use the Recharge Key to add more <u>gameplays</u> .
MODE CONFIGURATION	<ul style="list-style-type: none"> • Enable Amusement Gameplay • Enable S.W.P. Gameplay • Enable Tournament 	Choose which modes of play will be available to players.

Amusement Games Menu

Game Setup

The game list, prices, and options are programmed using these screens. The first screen shows the various game categories and allows access to the following general settings for all games.

To Enter This Screen, Touch “Game Setup” on the Games Menu and Select a Category



FIGURE 3 - GAMES MENU: GAME SETUP

Enable All Games Into Menu: Turns on all games and defaults the price settings.

Factory Default Games Into Menu: Returns the Game Setup to its default settings. Games that were not originally enabled will be turned off and all price settings will be reset.

When you touch a category name, the next Game Setup Screen shows the game positions available for that category and the price for each game, with the list at the bottom showing all games available for the selected category. In categories with Merit-thon games, players who choose Merit-thon play one round of three different games in that category for one combined score.

The Game Setup Screen also allows you to make these general changes:

Default Games: Resets the selected category menu to its default game and price settings.

Enable All Games: Turns on all games within the selected category and defaults the price settings.

Clear One: Clears a selected item from the player's game menu.

Clear All: Clears all games from the player's game menu.

To customize a particular game list, first select a category on the first Game Setup Screen. On the second screen, touch **Clear All** to clear the game list. Touch the menu position that you want a particular game to occupy, then touch the desired game name in the game list on the bottom of the screen. Repeat until all desired games appear in the menu. Games already in the menu will be red in the game list at the bottom of the screen.

To adjust price, touch the credit or currency value next to each game.

Amusement Hi Scores Menu

Use this screen to manage hi scores. The first screen allows you to clear all scores for all games by touching **Clear All Games**.

To Enter This Screen, Touch “View/Clear Hi Scores” on the Hi Scores Menu and Choose a Game

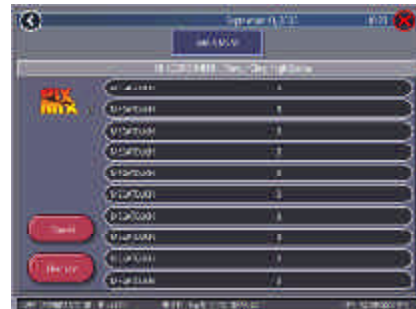

FIGURE 4 - HI SCORES MENU:
VIEW/CLEAR HI SCORES

To edit hi scores by game, select a game on the first screen. Touch **Clear All** to remove all hi scores for that game or remove an individual score by touching **Clear One**.

Books Menu

The Books Screens display the current and lifetime credit totals for each game, as well as the percentage of credits played per game (the percentage for each game is the total number of credits played on that game divided by the total number of credits entered into the machine).

Books Display

To Enter This Screen, Touch “Books Display” on the Books Menu



FIGURE 5 - BOOKS MENU: BOOKS DISPLAY SCREEN

The books information can be sorted in three ways by using the button that toggles through the sorting categories. **Unsorted** displays the books information in the standard order. **Sorted by Current** displays the current credits for each game from most to least played. **Sorted by LifeTime** displays the lifetime credits for each game beginning with the most played game.

Touch **Tournament Statistics** to get the books information for that mode of play only. Touch **Clear Current** to erase all current books data. Both the current screen and the **S.W.P. Statistics** screen will be erased. The date of the last data clear will appear at the top of the Books Screen.

Touching a game name will display the current and lifetime credit totals*. It also shows the shortest, average, and longest playing times for that game. Press **OK** to exit this screen.

***Touching Trivia or Power Trivia displays totals by category.**



FIGURE 6 - BOOKS MENU: BOOKS DISPLAY SCREEN WITH GAME SELECTED

Books Display shows coin input data, as well as Promotional Credits and Merit Money (when these features are enabled). Touch **Total Coins** to display individual coin input statistics. The following is a guide to this screen: 1A Coins = £2 (Value Added 20), 2B Coins = £1 (Value Added 10), 3C Coins = 50p (Value Added 5), 4D Coins = 20p (Value Added 2), 5E Coins = 10p (Value Added 1), 6F Coins = £5, £10, £20 (Value Added 50/100/200). Value Added is the amount of meter pulses each unit of currency adds.

NOTE: Books data can be exported to a file USB pen via the System Menu/Data Transfer/Export Books feature. The .dat file can then be viewed with Wordpad after connecting the storage device to a personal computer. The file will display basic game information such as the software version, the game serial number, and date/time information relating to books data. The file will also show the current and lifetime credit totals, as well as credit totals for each game featured on the machine.

Cash Settlement Setup

The Cash Settlement Screens are used to calculate the percentage of earnings the operator and location will receive, as well as any fees collected by the operator. This will help to offset costs.

To Enter This Screen, Touch “Cash Settlement Setup” on the Books Menu and touch “NEXT”

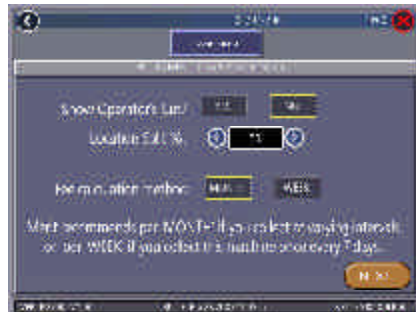

FIGURE 7 - BOOKS MENU:
CASH SETTLEMENT SETUP SCREEN

The first screens allow you to set up the Cash Settlement Screen. Choose **YES** or **NO** to display the operator's cut on the Cash Settlement Collection Screen and enter the percentage of revenue the location will receive. Also, select the fee calculation method. Select per month if you do not make regular weekly collections or per week if you collect every 7 days. Then touch **NEXT**.

NOTE: Monthly fee collections are based on 4.3 week month. If you change your fee calculation method, the game will auto adjust the fees by multiplying or dividing by 4.3 and rounding to the nearest penny.

NOTE: Make sure the time and date are set on the game in order to ensure correct fee calculation.

The next screen allows you to set up the fees. The amounts can be changed on-screen by touching the amount itself and using the keypad to enter a figure. The other two columns display the cumulative totals for each fee and the totals for the current



FIGURE 8 - BOOKS MENU:
CASH SETTLEMENT SETUP SCREEN

collection period. Fees are calculated on a prorated, per-day basis. Touch the **NEXT** button to display more groups of fees. After setting up the fees, touch **FINISH** to save your changes.

Cash Settlement Collection

The Cash Settlement Collection Screens will display the balance (Total Revenue minus Total Fees minus Refill Amount minus S.W.P. Payout) to be split between the operator and the location. The Refill Amount represents the amount of money put into the hopper by the operator or bartender to complete payouts.

Touch **Revenue Details/Cash Out** or **Fee Details** for in-depth financial breakdowns. Touch **Clear/Complete Collection** to finish. Cash Settlement totals will reset once collection is complete.



FIGURE 9 - BOOKS MENU:
CASH SETTLEMENT SETUP SCREEN

System Menu



FIGURE 10 - SYSTEM MENU

<p>Set Time</p>	<p>The Set Time Menu allows you to set both the time and date on the game. Time is shown in 24-hour, "military" time (e.g. 5:00pm = 17:00). Use the left and right arrows to find your time zone, then touch your selection to continue.</p>
<p>Security Setup</p>	<p>The operator can set the PIN number and select which of the features (Coin-In Menu, Free Credits, Game Menu, Hi Scores, Books, All Options, and Set 6 Star PIN) will be protected by the PIN. To change the PIN, enter the existing PIN (default is 0000), then enter a new 4-digit number and touch SET on the keypad. The game will prompt you to re-enter your PIN to confirm. After confirming your PIN, touch the button for each of the features you wish to protect with the PIN. NOTE: The Coin-In Menu is not applicable for this unit.</p>
<p>Set Game Serial Number</p>	<p>Use this screen to enter the game's serial number.</p>
<p>Volume Control</p>	<p>Touch the volume control button to adjust the volume up or down. You can sample the sound volume without exiting the screen.</p>
<p>Set 6 Star PIN (only appears if PIN is enabled)</p>	<p>Set the 6 Star PIN (between one and six digits) using this screen. You can enable this feature and choose which options will be accessible by 6 Star using the System Menu: Options Screen. Touch an option box under System Menu: Options for on-screen help. To access the selected options from the Player Menu Screen, touch Options, then 6 Star.</p>
<p>Data Transfer</p>	<p>Transfer information (Books data, ad screens) using a USB Pen.</p>
<p>Options</p>	<p>For help with the Options in any menu section, touch the option box to bring up a help screen.</p>

Diagnostics Menu



FIGURE 11 - DIAGNOSTICS MENU

Video Test	Touch the screen to cycle through a series of video test screens.
I/O Test	Tests the SETUP and CALIBRATE buttons, all coin channels, all 5 meters (Cash In, Cash Out, Hopper Refill, MegaNet Play, and Prize Pool), and Door Open, Refill Key, and Note Acceptor switches. A green light next to the appropriate button will register each time that item is tested, and the number next to the item should increment by one with each test. The I/O Test Screen also displays which DIP switches are on or off.
Touchscreen Calibration	Follow the on-screen instructions to calibrate the touchscreen.
Touchscreen Test	Allows you to check the touchscreen calibration accuracy. The cross should follow your finger exactly when you move it across the screen.
View System Log	Displays a log of all operations performed by the game since the log was last cleared. This information is helpful for customer service in troubleshooting your game.
Checksum Test	Checks the hard drive for missing or corrupted files. With STOP ON ERROR? set to YES, a message indicating which file is corrupted will be shown whenever the game encounters an error. With STOP ON ERROR? set to NO, a list of corrupted files will be displayed when the test is complete. If errors are detected, the software on the drive may need to be reloaded. If this does not solve the problem, the drive may require replacement. The test could take up to 30 minutes.
System Info	Gives details about the following: <ul style="list-style-type: none"> • processor type and speed • motherboard manufacturer • amount of memory • Ethernet card manufacturer • sound chip type • video chip type • touchscreen manufacturer • hard drive manufacturer and capacity • modem part identification number • fan speed (FORCE games only)

Presentation Menu

The Presentation Menu allows operators to create ad screens and upload custom screens created on a personal computer.

Operator Ad Screens

A total of 24 advertising screens can be created with the software and added to the game. The ads will appear along with the other attract screens when the game is in idle mode. Custom images for ad screens can also be added to the game using an appropriate storage device for your game (USB pen or CD). Touch the green ? buttons on each screen for information on how to create ad screens and add custom screens to the machine.

In addition, a program for adding up to 120 additional ad screens can be downloaded from our Web site (www.meritind.com) in the Support/Software Downloads section.

FORCE games only: A USB Pen Kit (kit number KAV-100-008-01) is available. To order, contact your authorized Merit distributor.

Promotion Menu

The Promotion Menu is designed to encourage player interest. Use the Options button to enable each feature. Once an option is enabled, the button will appear in the menu.



FIGURE 12 - PROMOTION MENU

My Merit (FORCE Games Only)

NOTE: My Merit is only available in Amusement mode. Players who are logged into My Merit and switch to S.W.P. or Tournament mode will automatically be logged out of My Merit.

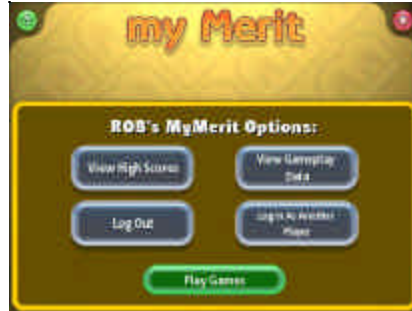

FIGURE 13 - MY MERIT OPTIONS

The My Merit feature allows individual players to create custom accounts accessible via PIN numbers. Accounts can be created **by touching the My Merit** button on the Player Menu Screen or by accepting the option to create an account after achieving a Hi Score.

Players will then have the choice to log in to their accounts through the My Merit button on the Player Menu and have personal data stored on the machine. Players can view their hi scores and the number of games they've played in My Merit mode for the past year.

NOTE: My Merit data will be cleared when a software update is performed. Be sure to back up the data before updating the game.

View Player Data

Select **My Merit** from the Promotion Menu, then touch **View Player Data** to bring up a list of all players with My Merit accounts. Touching a player's name will bring up the PIN, total number of games played, and date the account was created. The **Show Hi**

Scores button will display a list of the games on which the player has the hi score and the score itself. If desired, the operator can also reward the player with free credits through the View Player Data Screen.

Show Game Play Frequency

This feature shows the number of games played by each My Merit player. The operator can choose whether to display all totals or just those that fall within a certain date range.

Show Player Hi Scores

Selecting a game name under this feature will bring up the Hi Scores of each My Merit player for that game, as well as the date the score was achieved. The operator can choose whether to display all Hi Scores or just those that fall within a certain date range.

Backup/Restore

My Merit data can be backed up or restored with a USB pen. After connecting a pen to the machine, touch this button to proceed with backing up or restoring all My Merit data. USB pen kits (kit number KAV-100-008-01) are available. To order, contact your local distributor.

NOTE: Restoring My Merit data from a storage device will erase any My Merit data currently on the game. Conversely, backing up data onto the USB pen will also overwrite any existing My Merit data on the USB pen.

Merit Money

The Merit Money screens allow location owners to encourage game play by offering free games (not free credits) at certain time intervals via the 6 Star Feature. Select days of the week, time frames, and the number of free games (1-10 per day) to be awarded, as well as a PIN number for location owners to use to access Merit Money through 6 Star. Location owners can enable Merit Money by entering that specific PIN in the 6 Star screen. One free game is given away each time the location enters the code until the predetermined daily limit is reached. Free games expire after 10 minutes, when money is deposited into the machine, or when the Merit Money time period comes to an end.

Promo Credits

The Promo Credits feature generates interest by offering operator-controlled free credits while the game is in idle mode. Select days of the week, time frames, idle time (number of minutes the game is in idle mode before free credits are offered) and the number of credits (1-10) to be awarded. A message announcing that free credits are available will appear on the screen during idle mode when Promo Credits go into effect. Promo Credits expire after 10 minutes or when the Promo Credits time period comes to an end.

S.W.P. Menu

Skill With Prize mode rewards players with coin jackpot payouts. When predetermined score levels are reached, players earn money that is put in a Bank. The amount in the Bank is displayed on the Player Menu Screen. At any time, players can press **Cash Out** to collect their winnings. In other modes, touch the **Bank** button, then press **Cash Out**.

If a player runs out of credits, money from the Bank can be converted to credits in £1 increments to pay for continued play.

Game Setup

To Enter This Screen, Touch "Games" on the S.W.P. Menu



FIGURE 14 - S.W.P. GAMES MENU: GAMES SETUP SCREEN

The game list is programmed using the Games Setup Screen. Select the Game Status for each game by touching **Auto**, **Locked In**, or **Disabled**. Use the scroll bar on the right to scroll through all games.

Auto: The game will rotate in and out of the player menu based on popularity. Use the arrows under **Rotation Frequency** to choose how often the game's popularity is calculated (1-6 weeks). The default setting is 4 weeks. To disable the auto adjust feature, set **Rotate Game** to No.

Locked In: The game will always appear in the menu.

Disabled: The game will never appear in the menu.

NOTE: If Rotate Game is set to No, but some games are set to Auto, they may appear in the Player Menu if the maximum number of games are not locked into the menu.

The auto-rotation time period is reset each time the **Clear/Complete Settlement** button is pressed in the Books: Cash Settlement Menu or **Clear Current** is selected in the Books Menu: Books Display Screen.

Statistics Screen

To Enter This Screen, Touch "Statistics" on the S.W.P. Menu



FIGURE 15 - S.W.P. MENU: STATISTICS SCREEN

The S.W.P. Statistics Screen shows financial statistics, including Profit, Cash In, Cash Out, Payout %, and Days (days the game has been on the Player Main Menu). These reports can be toggled in the second column by pressing **Last** (last collection period), **Lifetime**, and **Lifetime Since** (since last payout percentage change). Current statistics will always display in the first column. Press **Dump Data to USB Pen** to transfer game statistics. The data can then be viewed by using WordPad.

Touch individual game names for the number of payouts at each level, total games played, and total winning games since the last target payout change.

You can open the game and directly refill the hopper. See the **Hopper Setup** section of this manual.

The hopper can also be refilled without entering the SETUP screens. Turn the Refill Key (see Figure 20). Keep the key in this position, then insert the desired amount of £1 coins directly into the coin acceptor to refill. On the **Landlord Audit** screen that displays, the following information is stored:

Last Bank: Current amount in the player's bank.

Last Win: Most recent amount won by player.

NOTE: The Refill Key cannot be used while in the SETUP Menu Screens.

To display the **Operator Audits** screen, open the top bezel, then turn the Refill Key and begin entering £1 coins into the coin acceptor. This screen shows **Last Bank**, and **Last Win** in addition to the following:

Cash In: Total coin input or transferred credits (winnings in bank used as credits instead of paid out).

Cash Out: Total winnings paid to players.

Coins in Hopper: Number of coins currently in the hopper.

NOTE: The Audits Screen will reset when the Books are cleared or a collection is completed.

If the game still owes a player winnings, the error "**Last Payout Incomplete, still to pay £(X)**" will display on both of the refill screens. Once the hopper is refilled, a **Complete Payout** button will display. Touch this button so the player will receive the rest of their winnings.

Remove the Refill Key when you are done refilling the hopper.

Set Security PIN Screen

This PIN is used to access the SETUP Main Menu and is entered at the keypad that displays after opening the top bezel. To change your PIN, press the **Set Security PIN** button. Use the keypad to enter your desired PIN number, then press **ENTER**.



FIGURE 17 - S.W.P. MENU:
SET SECURITY PIN SCREEN

Recharge Key

See the Recharge Key Instructions sheet provided with your Money Shoot Recharge Key Kit for more information.

Mode Configuration Menu

Check the boxes to choose which gameplay modes are activated. If none are selected, the game will default to Amusement mode. If Tournament is selected, choose between TournaCHAMP and Championship Edition.

Tournament modes may require the purchase of additional kits. A Modem Installation Kit (part number KUV-113-001-01) and a Championship Edition Kit (part number KUV-113-003-01) are available for purchase through your Merit distributor

NOTE: If no tournaments are running, do not select Tournament mode as the only enabled play mode.

IMPORTANT! Before turning off or switching Tournament modes, complete a Cash Settlement Collection. See the Books section of this manual for more information.

DIP SWITCH SETTINGS

The following table provides information on the functionality of the hard DIP switches in Megatouch games. Make sure to read the information in the **Notes** column to determine what is affected when performing these functions. After performing any DIP switch function, make sure to follow the instructions on the screen. In most cases, you will be instructed to reset the DIP switch in order to reboot the game. If you fail to reset the DIP switch before rebooting, it could result in corruption of the hard drive.

NOTE: In FORCE 2005 and Jade software, the DIP switch functionality is built into the software. To access the DIP switches through the software, turn off the game, set DIP switch 1 to the closed position then turn the power on. When the message “**Please reset DIP 1 to proceed**” appears, reset DIP 1 to the open position. The Merit diagnostics page will appear. Touch ? for information on DIP switch functionality. Touch the specific DIP switch to activate it. Touch X to exit.

FORCE 2003 / MAXX Ruby and greater		
DIP#	Function	Usage/Notes
8	Motherboard configuration & checksum test	<ul style="list-style-type: none"> Configures the CMOS settings on the motherboard to Merit specifications and checks the files on the hard drive. A checksum test should be performed when the game is locking up or rebooting. If the test fails, the program should be reloaded onto the hard drive. After reloading, perform another checksum test. If it fails again, the hard drive should be replaced.
6	Hardware configuration	<ul style="list-style-type: none"> Identifies system hardware and configures the motherboard. A hardware configuration occasionally needs to be performed after a kit is installed and the touchscreen is not responding to touch or the calibration is off.
5 & 7	Memory clear for TournaCHAMP and TouchTunes®	<ul style="list-style-type: none"> Clears the login name, password, access phone number, and all call-in settings for TournaCHAMP users. Clears all the loaded albums for TouchTunes users. Clears current books, coin-in, high scores and resets the software options. <p>A memory clear should be performed when a game is not able to connect to TournaCHAMP and there is some question about the information in the Dial-Up Network Screen being correct. After performing a memory clear, TournaCHAMP setup information must be re-entered, and an Update From Server should be performed.</p> <p>NOTE: TournaCHAMP games must perform an “Update From Server” BEFORE performing a memory clear.</p>
4 & 7	Complete memory clear	<ul style="list-style-type: none"> Clears ALL memory on hard drive including the TournaCHAMP player database, TournaCHAMP settings, advertising screens, bookkeeping, high scores, coin-in, options, etc. It resets the game to the factory defaults. It also marks bad sectors on hard drive. <p>A complete memory clear should only be performed when the game is locking up or resetting and it has passed the checksum test. After performing a memory clear, the player database should be reloaded, TournaCHAMP setup information must be re-entered, and an Update From Server should be performed.</p> <p>NOTE: TournaCHAMP games must perform an “Update From Server” BEFORE performing a memory clear.</p>
3	Watchdog Timer (EVO, Fun Zone, Fusion & Money Shoot)	<ul style="list-style-type: none"> When the watchdog timer is enabled, it will reboot the machine within 2 minutes of a failure, allowing the game to automatically reset itself if a problem arises.

Merit Industries, Inc.
Troubleshooting Guide for *Megatouch FORCE™ Games*

PROBLEM	CORRECTIVE ACTION
<ul style="list-style-type: none"> • no power • bill acceptor motor does not run • no flash on the monitor screen • no cooling fans operating • no output from power supply 	<ul style="list-style-type: none"> • Check that the power cord is connected to a "live" outlet. • Check that the power switch is on. • Check that the power cord is connected to the game power supply. • Check that the power supply's voltage select switch is set to the proper voltage. • Check the harness connections to the on/off switch and circuit breaker. • Check the circuit breaker for an "open". • Check the A/C harness connection to the power supply. • Check the line cord.
<ul style="list-style-type: none"> • no video • no cooling fan operation • screen is blank • A/C power to the monitor and bill acceptor • no output from power supply 	<ul style="list-style-type: none"> • Check the power on jumper wire located on the motherboard. It should connect J2 to pin 21 of Panel 1. If this jumper wire is missing or not connected between the correct pins, it may prevent the power supply from turning on. For more information, see Tech Note 52. • Check the D/C harness connection to the motherboard. • Check the A/C harness connection to the power supply.
<ul style="list-style-type: none"> • no video • cooling fans are working • there is a sound when coins are deposited 	<ul style="list-style-type: none"> • Check the video cable connections to the motherboard and the LCD display. • Check the harness connections between the PC board s on the back of the LCD display. • Replace the LCD display.
<ul style="list-style-type: none"> • no video • constant beeping or a sequence of beeps 	<ul style="list-style-type: none"> • The memory card (DIMM) may not be seated properly. Reseat the DIMM or replace it.
<ul style="list-style-type: none"> • no video • no sound when coins are deposited 	<ul style="list-style-type: none"> • Check all connections to the motherboard. • Reseat the DIMM. • Replace the motherboard or send it for repair.
<ul style="list-style-type: none"> • poor picture quality 	<ul style="list-style-type: none"> • Adjust Brightness, Contrast, Horizontal, and Vertical controls with monitor controls.
<ul style="list-style-type: none"> • coin jam 	<ul style="list-style-type: none"> • Check the coin mech and coin chute for coins blocking the pathway. • Make sure the coin harness is connected between the normally open and common terminals on the coin switch. • Disconnect the bill acceptor and the coin switch one at a time to narrow down the problem. • Check the coin harness for pinched or damaged wires. • Disconnect the coin harness from J1, J3, J7, and J8 of the I/O board. If the coin jam still appears, the I/O board will have to be sent for repair.
<ul style="list-style-type: none"> • meter not advancing 	<ul style="list-style-type: none"> • Check connection at I/O board. • Check wiring at J2 METER connector on I/O board.
<ul style="list-style-type: none"> • "INVALID KEY" message while downloading software to the hard drive 	<ul style="list-style-type: none"> • If the security key was replaced before the download:- The motherboard did not boot from the CD-ROM drive.- • Check that the CD-ROM drive is set as master. • Check the ribbon cable connections between the CD-ROM drive and the motherboard.- • Try another CD-ROM drive or another set of CDs.
<ul style="list-style-type: none"> • "CRITICAL ERROR ABORT RETRY FAIL" or "BAD COMMAND OR FILE NAME" error 	<ul style="list-style-type: none"> • Try reloading the program onto the hard drive with a different set of update CD's compatible with the security key. If it will not accept the download, try another CD-ROM drive. If it still does not work, replace the hard drive.

Merit Industries, Inc.

Troubleshooting Guide for *Megatouch FORCE™ Games continued*

PROBLEM	CORRECTIVE ACTION
<ul style="list-style-type: none"> • game locks up or resets while being played or in the attract mode • no movement on the screen • power has to be cycled off and on to get the game to function again 	<ul style="list-style-type: none"> • Clean the vents and the fans of any dust and dirt that may interfere with airflow. • Clean the CPU cooling fan on the motherboard. • Replace the CPU cooling fan if it is not operating properly. • Reseat the DIMM on the motherboard. • Clear memory with the following procedure: <ul style="list-style-type: none"> • Turn off the game. • Press and hold the Setup and Calibrate buttons. • Turn the game on and keep holding the buttons until the screen displays "TWO BUTTON CLEAR DETECTED RELEASE BUTTONS". This should take about 30 seconds. • Release the buttons. This will clear high scores, clear the books and reset options, and re set the game menu and coin menu to their factory settings. • Perform a checksum test on the hard drive: <ul style="list-style-type: none"> • Turn off the game. • Turn on DIP switch 8 on the I/O board. • Turn on the game. The test will take about 10 minutes. <ul style="list-style-type: none"> • A failure will cause the test to stop. • A passed test will display "DRIVE CHECKSUM COMPLETE RESET ALL DIP SWITCHES TO REBOOT MACHINE". • With power on, turn off DIP switch 8.
<ul style="list-style-type: none"> • game locks up with "invalid key for version PG3002 – V XXXX" • "DISK BOOT FAILURE" • "QUANTUM FIREBALL, SMART FAILURE DETECTED, BACK UP HARD DRIVE" 	<ul style="list-style-type: none"> • Check the program number on the security key. It should be compatible with the program on the hard drive. • Check the contacts on the security key socket. Lift up on the contact on the bottom of the socket and make sure there is a good connection to the base of the security key. • Check the USB cable that connects the I/O board to the motherboard. • Check jumpers JP5 and JP6 on the I/O board. The USB cable can be connected to two connectors on the I/O board (J5A and J5B). The position of the shunts on jumpers JP5 and JP6 will enable either J5A or J5B. The shunts should be positioned towards the connector where the USB cable is connected. For more information, see Tech Note 55. • Try another security key with the same program number or test the security key in another game with the same program version. • This message indicates the motherboard is not receiving data from the hard drive and has locked up. • Check the IDE ribbon cable connections to the motherboard and hard drive. • Check the power to the hard drive. It should have +5 volts, +12 volts, and ground. • The self-diagnostics on the hard drive has detected an error. The hard drive will have to be replaced.

Merit Industries, Inc.

Troubleshooting Guide for *Megatouch FORCE™ Games continued*

PROBLEM	CORRECTIVE ACTION
<ul style="list-style-type: none"> • game will not download CD 	<ul style="list-style-type: none"> • Make sure the CD is installed correctly, with the logo facing up. • Check for scratches or a defective CD. • Try a different CD-ROM drive or another set of CDs. • If you're downloading a CD set, make sure each CD is of the same revision.
<ul style="list-style-type: none"> • "ERROR READING DRIVE C" 	<ul style="list-style-type: none"> • This message can be caused by the hard drive or in some program versions, a coin jam while the game is turned on. <ol style="list-style-type: none"> 1. Turn the game off. 2. Locate DIP switch 8 and turn it on. 3. Turn on power to the cabinet. This will start the hard drive checksum test, which should take about 20 minutes to complete. 4. When the hard drive passes the test it will display a "CHECKSUM GOOD" message and continue to boot up into the game attract screens. This indicates a coin jam. 5. When the hard drive fails the test, the game will lock up with a "CHECKSUM ERROR" message, which will stay on the screen until the power is turned off. In this case, the hard drive will have to be replaced.
<ul style="list-style-type: none"> • "DISK BOOT FAILURE" 	<p>This message indicates the motherboard is not receiving data from the hard drive and has locked up.</p> <ul style="list-style-type: none"> • Check the IDE ribbon cable connections to the motherboard and hard drive. • Check the power to the hard drive. It should have +5 volts, +12 volts, and ground.
<ul style="list-style-type: none"> • "QUANTUM FIREBALL, SMART FAILURE DETECTED, BACK UP HARD DRIVE" 	<p>The self-diagnostics on the hard drive has detected an error.</p> <ul style="list-style-type: none"> • The hard drive will have to be replaced.
<ul style="list-style-type: none"> • "CRITICAL ERROR ABORT RETRY FAIL" or "BAD COMMAND OR FILE NAME" error 	<ul style="list-style-type: none"> • Try reloading the program onto the hard drive with a different set of update CD's compatible with the security key. If it will not accept the download, try another CD-ROM drive. If it still does not work, replace the hard drive.

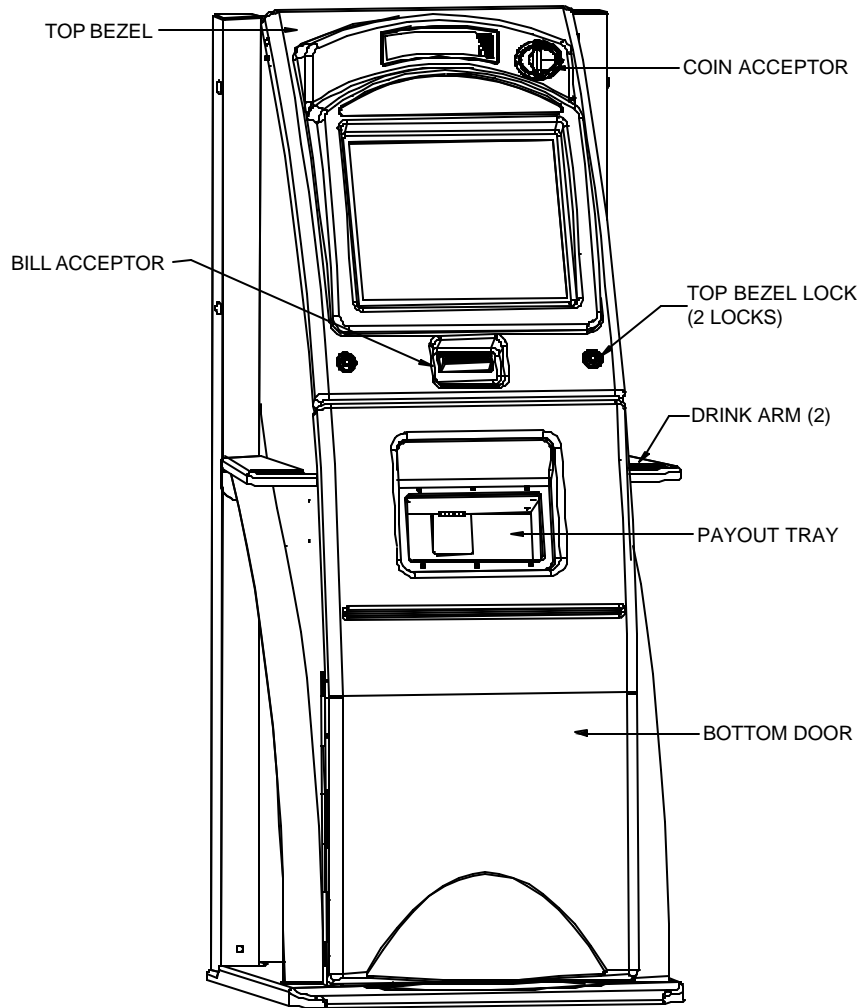

FIGURE 19 - FRONT VIEW, CLOSED BEZEL

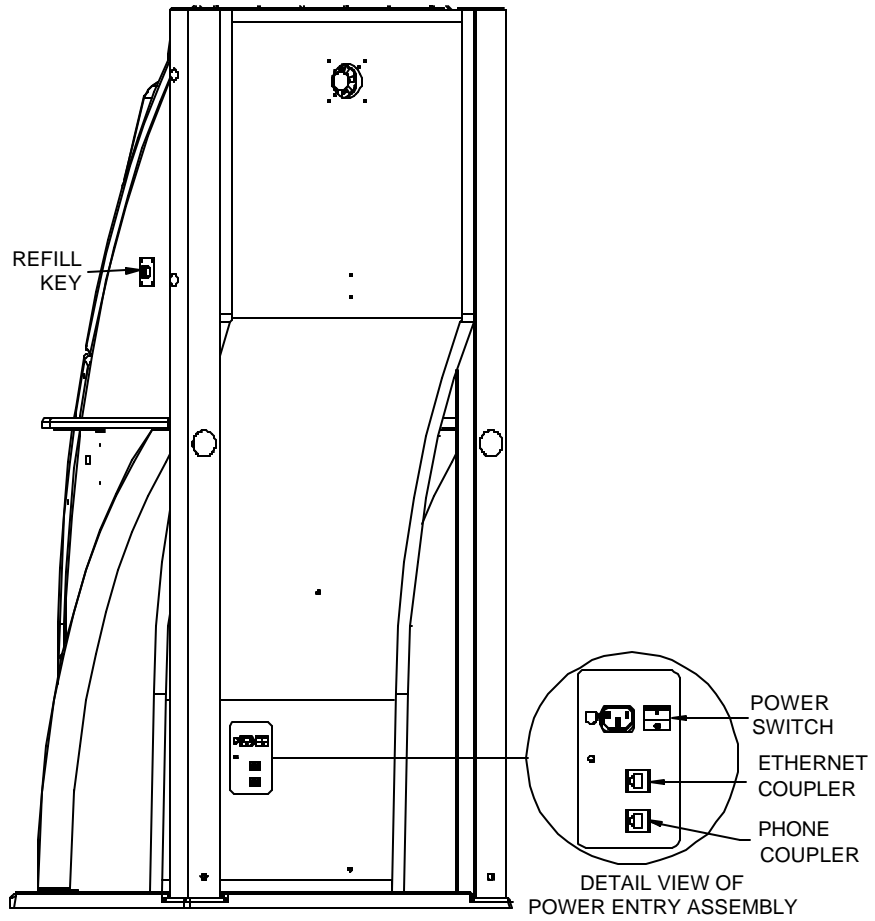

FIGURE 20 - REAR VIEW

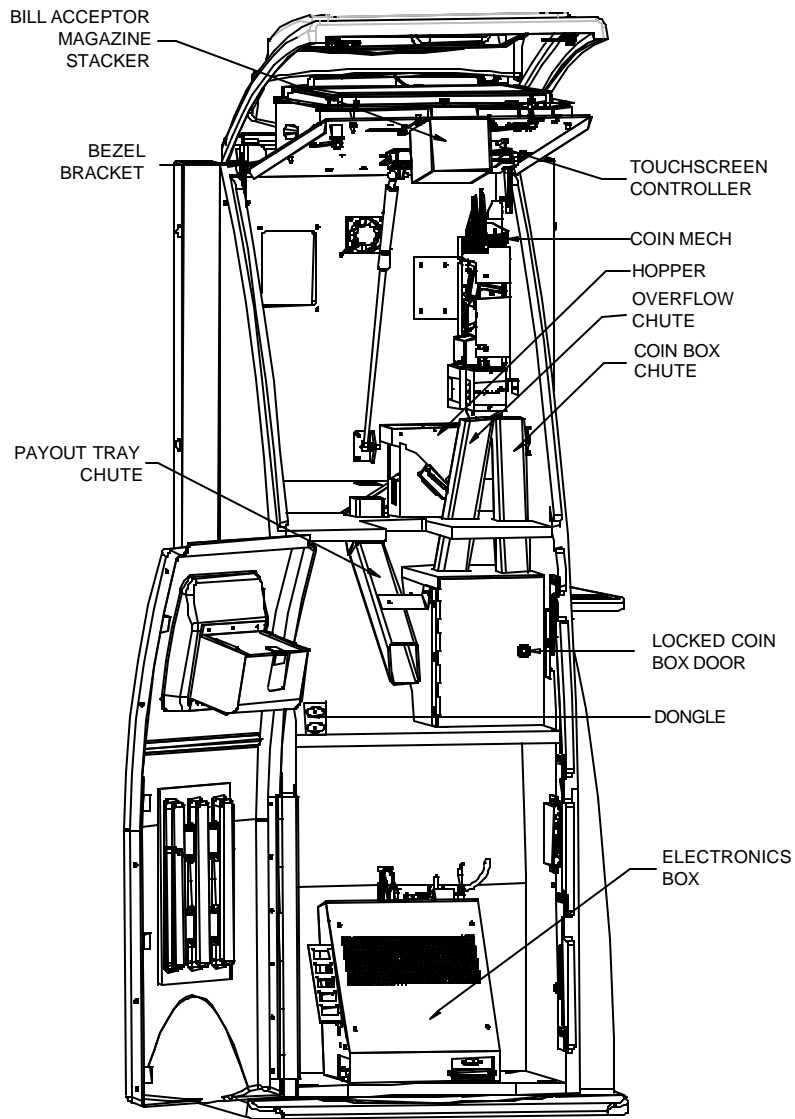

FIGURE 21 - FRONT VIEW WITH ALL BEZELS OPEN

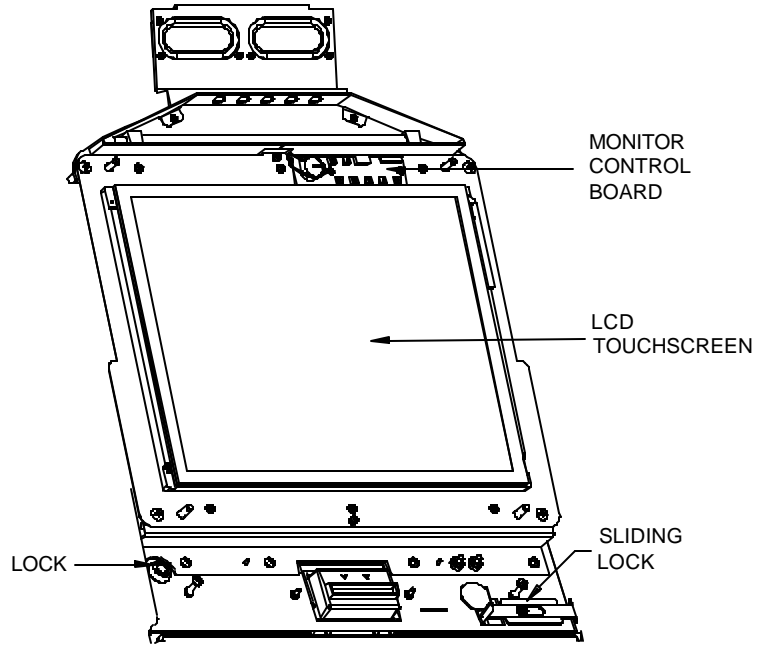

FIGURE 22 - DETAILED VIEW OF MONITOR ASSEMBLY

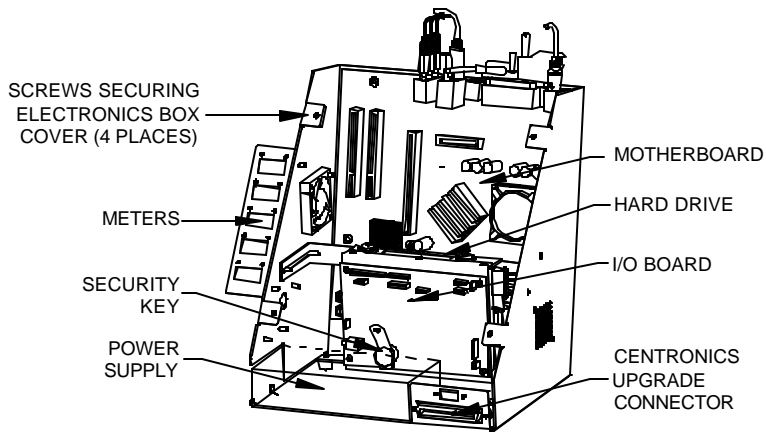

FIGURE 23 - DETAILED VIEW OF ELECTRONICS BOX WITH DOOR OPEN

Megatouch Money Shoot Replacement Parts List

REPLACEMENT COMPONENTS MONEY SHOOT (G21-116-001-01)	
PART NUMBER	DESCRIPTION
SA10057-07	MOTHERBOARD
EC9702-09	SMILEY BILL ACCEPTOR, UK
EC7536-01	POWER SUPPLY, 125W ±12, ±5, +3.3
EC9851-03	17" TOUCHSCREEN OVERLAY
EC9384-02	17" LCD DISPLAY
EC9840-10	MICROTOUCH SMT4 TOUCHSCREEN CONTROLLER
SA3094-11	UK, 2ND, SWP 2K5 KEY
SA3095-11	UK, 1ST, SWP 2K5 KEY
PA3022-01	FORCE 2005.5 HARD DRIVE

NOTE: The parts in your game may vary. When calling for replacement parts, make sure to have your serial number available to ensure the accuracy of your order.

NOTE: In order for your Megatouch FORCE game to function properly, the hardware must only be replaced with FORCE hardware. Replacing the motherboard, I/O board, hard drive or touchscreen controller with hardware that is not specific for FORCE will eliminate some of the FORCE software features.

For additional assistance, after contacting your distributor, contact:

CVA Customer Service
020.8594.1234

Merit Industries, Inc. P.O. Box 5004, Bensalem, PA 19020-8529.

You can also visit our Web site
www.meritind.com

Connection Diagrams

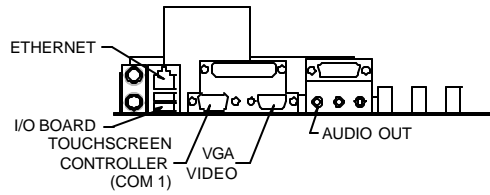
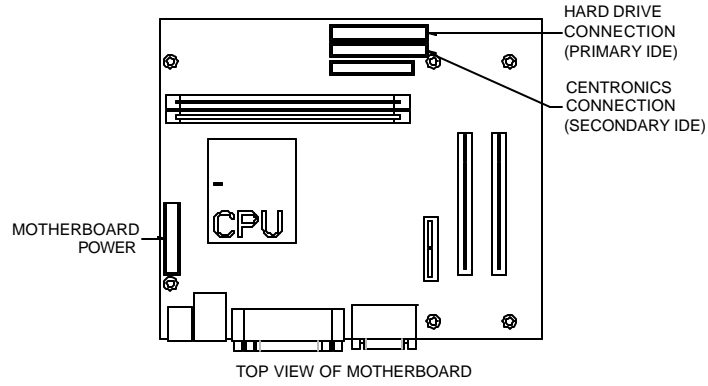

FIGURE 24- CONNECTOR SIDE OF ECS MOTHERBOARD

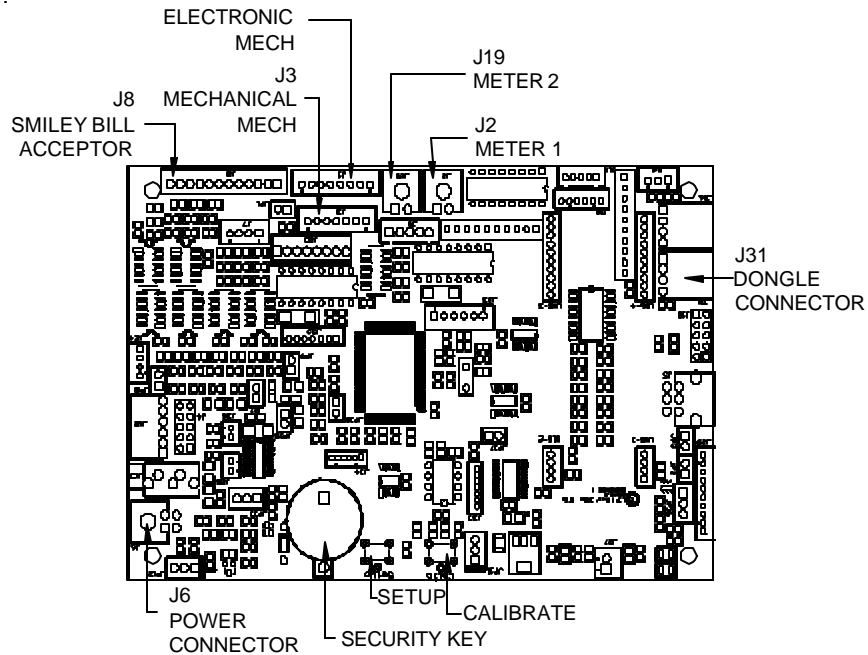

FIGURE 25 - I/O BOARD DRAWING

Megatouch TournaCHAMP™ Edition

NOTE: For all U.K. operators, U.K. TournaCHAMP™ Central Administration will provide the Internet Service for dial-up connections. You can choose to use your own ISP but certain large Internet providers like AOL™, CompuServe™, Prodigy™, and NetZero™ utilize a proprietary dial-up protocol that is not industry standard and may not work with TournaCHAMP™. Some of the major providers that are compatible with TournaCHAMP™ are ATT Worldnet™, Sprint™, Erols™, Tymenet™, and EarthLink™, and most of the smaller local Internet providers. You can also now choose between Dial-Up, Automatic, and Manual Internet access. Dial-up uses the internal modem and standard phone line and Automatic and Manual use cable or DSL modems. You must have your own ISP to use the Automatic or Manual connection methods.

Overview

Merit's TournaCHAMP™ is a fully automated Tournament system designed to network Megatouch games over the Internet, for the purpose of playing in tournament games. All Tournament configuration and maintenance is controlled by a central server, which is managed by Merit's Tournament Manager. Placing the Tournament Management responsibilities in the hands of a Tournament Manager greatly simplifies the operator's role.

The system allows any number of Megatouch games to participate, by connecting to the server over the Internet. To participate, an operator only needs to fill out the Game Start-Up Form and fax it to U.K. TournaCHAMP™ Central Administration at 020 8594 1235, install the kit into an existing game and connect the game to the Internet.

Players register directly on the game and only need to register once for any tournaments run by that server. Scores are based on the average of five games, with the winner(s) having the highest average score.

TournaCHAMP™ is a tournament promotion system, allowing players to compete for a prize pool based on the income from premium-priced tournament games. The top scorer(s), at the completion of a tournament, is entered into the Winners List for retention until they claim their prizes.

Players who achieve a winning score(s) during a tournament must enter their name, along with their own personal identification number (PIN). Should they win in that tournament, the PIN will be used to ensure positive identification of the player. Provided an attendant is present, prizes may be claimed anytime after the completion of a tournament. Once the prize is awarded, it is noted on the Winners List and is accounted for in the bookkeeping statistics. The operator can choose to collect and pay the prize money, have TournaCHAMP™ Central Administration collect and pay the prize money or chose to do both.

TournaCHAMP Installation Instructions

If your game did not come equipped with a modem, you must purchase an additional Modem Installation Kit (part number KUV-113-001-01) to utilize TournaCHAMP mode.

Dial-Up Internet Setup

If you are using a broadband Internet connection, skip to **Broadband Internet Setup**.

1. Connect the supplied phone cable to the phone coupler (bottom coupler) on the outside of the game. If the phone cable has a ferrite attached to the end of it, make sure this end is closest to the game.
2. Plug the other end of the phone cable into the provided telephone adapter. Then plug the adapter into a telephone socket.
3. Continue with **On-Screen Configuration Guide**.

Broadband Internet Setup

NOTE: A broadband router is required in order to connect Megatouch games to a broadband Internet connection. You will need either a broadband router with a built-in broadband modem or a broadband router and an external broadband modem. If you are also linking games, you may also require a router with a built-in hub or an external 10 BASE-T Ethernet hub depending on how many games you are linking and how many available ports are on the router. (Hubs are available from your distributor as a separate part, EC0030-01, or at your local computer store.)

NOTE: Your broadband Internet connection should already be connected and configured using the instructions provided by the manufacturer and by your Internet Service Provider before continuing with this installation.

1. Turn off the game and disconnect it from its power source.
2. Connect the supplied Ethernet cable to the Ethernet coupler (top coupler) at the back of the game. If the Ethernet cable has a ferrite attached to the end of it, make sure this end is closest to the game.
3. Connect the free end of the Ethernet cable to the broadband router.
4. Continue with **On-Screen Configuration Guide**.

On-Screen Configuration Guide

In order to continue with this On-Screen Configuration Guide, your Game Start-Up Form must be filled out and received by U.K. TournaCHAMP Central Administration.

1. Press the SETUP button and enter your PIN to access the Main Menu.
2. Touch the **Mode Configuration** button. Ensure that Enable Tournament is selected and TournaCHAMP is chosen.

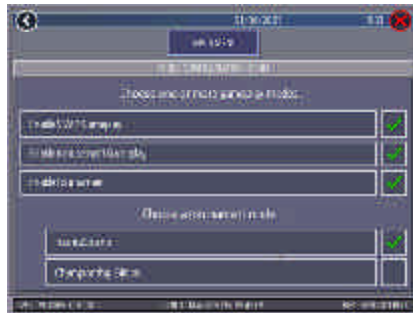

FIGURE 1 - TOURNACHAMP MENU SCREEN

3. Return to the Main Menu and touch the **Tournachamp** button. The Set Game Serial No. Screen will appear. At this screen, enter the game's serial number and touch **ENTER**. The game will then prompt you to enter the time zone. The times are listed using Greenwich Mean Time. Scroll through the list to find your time zone and select it by touching it. The game will then return to the Tournachamp Menu.

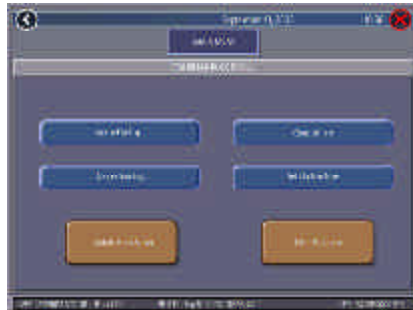

FIGURE 2 - TOURNACHAMP MENU SCREEN

BUTTON	DESCRIPTION
INTERNET SETUP	Accesses Tournament Set-Up.
GENERAL INFO	Shows location information, last successful update and attempted updates.
CONNECTION LOG	Displays the last 15 update attempts.
SET UPDATE TIME	Select the daily time for the machine to update information and rankings from the Tournament server. NOTE: GAME MUST BE TURNED ON IN ORDER TO UPDATE. If it is not turned on at the scheduled time, it will dial in the next time the machine is turned on.
UPDATE FROM SERVER	Updates Tournament game rankings and game information from your machine to the Server.
CLEAR DATABASE	Erases ALL Tournament, Location, or Player information from the machine. After selecting Clear Database the game will prompt you to select which database to clear. CAUTION: CLEARING THE DATABASE MAY CAUSE A LONG DOWNLOAD ON THE NEXT UPDATE.

4. At this screen, touch the **Internet Setup** button (see Figure 2) to access the Internet Setup Screen.
5. At the Internet Setup Screen, select **Dial-Up**, **Automatic**, or **Manual** depending on how you are connecting to the server.

Dial-Up: This connection method uses a standard phone line and TournaCHAMP Central's ISP or your own ISP. For Dial-Up connections, continue with step 6.

Automatic: The automatic setting is for cable or DSL connections using dynamic IP addresses. Contact your Internet service provider if you are unsure of what kind of IP address they use. For Automatic connections, continue with step 12.

Manual: The manual setting is for cable or DSL connections using static IP addresses. Contact your Internet service provider if you are unsure of what kind of IP address they use. For Manual connections, continue with step 14.

Dial-Up Only

6. After selecting Dial-Up, touch the **Dial-In Setup** button. This will take you to the Dial-In Setup Screen. See Figure 4.
7. At this screen, touch **YES** or **NO** after **Wait For Dial Tone** depending on whether or not you have to wait for a dial tone before dialing. Select a dialing method (either tone or pulse). In the **Include Area Code** section, select **YES** or **NO** depending on whether or not you have to use an area code to dial local number. If you need to use a dialing prefix (such as a number to reach an outside line) use the keypad to enter the number. Insert a comma after the number if an internal phone system needs time to connect to an outside line or to wait for a dial tone. Each comma forces a delay of one second before dialing. Select the speed of the dialing (it is recommended that this remain at FAST unless there is a problem dialing out). Select to have the modem sound turned off, quiet or loud. After all of these settings have been entered, touch the < button to return to the Dial-Up Network Screen (see Figure 3).
8. At this screen, select **USE MY OWN ISP**. The game will prompt you to enter the access phone number, login name and password. Touch the **NEXT** button to successfully enter in all the required fields. Then, touch the **YES** button to establish connection and begin the registration process.
9. After connection has been established, your information will appear on the screen. Touch the **YES** button to confirm the entered information.

To Enter This Screen, Touch the “Dial-In Set-Up” Button at the Internet Setup Screen.



FIGURE 3 - DIAL-IN SETUP SCREEN

10. Touch the < button. At this screen, touch the **Update From Server** button. The game will connect to the server (see Figure 4). Your first connection may take up to 40 minutes.
11. To confirm that a proper connection took place, touch the **Connection Log** button on the TournnaCHAMP Menu Screen. If there were no errors, you will see **"SUCCESSFUL"** at the Connection Log Screen (see Figure 5). If there is an error message, check the troubleshooting guide and follow the corrective action to fix the problem. Touch the **X** button on the Connection Log Screen and confirm that you want to exit out of the setup screens. Continue with **Beginning Tournament Play**.

Automatic Only

12. After selecting **Automatic**, press the **Setup** button. The game will prompt you to confirm the default Server IP, Primary DNS and Secondary DNS information. Touch the **NEXT** button to accept these defaults. The game will then try to connect to the server. Touch the **YES** button for the game to connect and complete the registration process. The game will connect to the server (see Figure 4). Your first connection may take up to 40 minutes.
13. To confirm that a proper connection took place, touch the **Connection Log** button on the TournACHAMP Menu Screen. If there were no errors, you will see "**SUCCESSFUL**" at the Connection Log Screen (see Figure 5). If there is an error message, check the troubleshooting guide and follow the corrective action to fix the problem. Touch the **X** button on the Connection Log Screen to exit. Continue with **Beginning Tournament Play**.

Manual Only

14. After selecting **Manual**, press the **Setup** button. The game will then prompt you to enter the Static IP Address. Enter the Address given to you by your service provider and touch the **NEXT** button. Then, enter the Gateway given to you by your service provider and touch the **NEXT** button. The Server IP, Primary DNS Address and Secondary DNS Address will already be filled out, simply touch **NEXT** to accept the default information. The game will then try to connect to the server. Touch the **YES** button for the game to connect and complete the registration process. The game will connect to the server (see Figure 4). Your first connection may take up to 40 minutes.
15. To confirm that a proper connection took place, touch the **Connection Log** button on the TournACHAMP Menu Screen. If there were no errors, you will see "**SUCCESSFUL**" at the Connection Log Screen (see Figure 5). If there is an error message, check the troubleshooting guide and follow the corrective action to fix the problem. Touch the **X** button on the Connection Log Screen to exit. Continue with **Beginning Tournament Play**.

To Enter This Screen, Touch the
 “Update From Server” Button at the
 TournaCHAMP Menu Screen



FIGURE 4 - MANUAL UPDATE SCREEN

Manual Update

If the game fails to connect, a red **X** will appear over the part of the process that failed. Reference the **Troubleshooting Guide** in this manual to correct the problem.

An **X** on the game:

- No modem detected
- Modem unavailable
- Machine serial number not valid
- No machine serial number
- Invalid security key

An **X** on the first arc:

- No dial tone
- ISP phone line is busy
- Modem lost phone connection
- ISP not answering

An **X** on the WWW:

- ISP not responding
- Unable to connect with ISP
- Connection to ISP interrupted
- Login information not accepted by ISP
- No information received. Disconnecting
- Unable to configure connection with ISP
- Server not responding to requests
- ISP not responding properly to requests

An **X** on the second arc:

- Unable to detect server

An **X** on the Merit House:

- Server not responding
- Server error
- Invalid information received

To Enter This screen, Touch the
 “Connection Log” Button at the
 TournaCHAMP Menu Screen



FIGURE 5 - CONNECTION LOG SCREEN

Connection Log

The numbers following the time and date of the last connection attempt have the following meanings:

M - manual update

1 - 1st attempt of an automatic update

2 - 2nd attempt of an automatic update

3 - 3rd attempt of an automatic update

If the status message is displayed in green it was a successful connection. Status messages displayed in red are unsuccessful connection attempts.

Beginning Tournament Play

16. Touch the **TournaCHAMP** button on the Player Menu Screen to begin Tournament play.
17. Select the Tournament game that you want to play (see Figure 6). Select **Rankings** on this screen to view the current Tournament rankings.

To Enter This Screen, Touch the “TournaCHAMP” Button on the Player Menu Screen.



FIGURE 6 - AVAILABLE TOURNAMENT MATCHES

18. To register a new player, touch the **NEW PLAYER** button to begin registration. At this screen enter all required information. For registered players, simply enter your name and PIN.

NOTE: Register on the game by entering required information (Name, Address, Phone number, etc.). This information is required to determine Tournament winners. A player only needs to register once, and can then participate in any Tournament available on the Tournament system.

19. Once the required fields have been entered, confirm that all the information is correct. Touch the **NEXT** button to view the Tournament disclaimer.

20. Touch the **ACCEPT** button to begin play. Touch the **DECLINE** button to delete ALL entered information.
21. Once you log in, the TournaCHAMP Player Screen will appear. From this screen you can view your top scores or enter the ranking screens to compare your scores to other players. See Figure 8.

After player registration is complete, confirm or make changes to your information as needed.



FIGURE 7 - PLAYER INFORMATION SCREEN

To Enter This Screen, Touch the “ACCEPT” Button on the Disclaimer Screen or Log In.



FIGURE 8 - TOURNACHAMP PLAYER SCREEN

Awarding Local Prizes

Players qualify for prizes by finishing with one of the top 3 high scores for the tournament. National prizes are awarded by sending a Winner's Claim Form directly to U.K. TournaCHAMP Central Administration. Operators can choose to award local prizes the same way as National prizes and be invoiced for the amount paid, or award local prizes from the cash box money. Follow the instructions below to award a local prize from the cash box.

23. Touch the **TournaCHAMP** button on the Player Menu Screen.
24. Touch the **RANKINGS** button on the TournaCHAMP Main Menu Screen to access the Rankings Screen. See Figure 9.
25. Touch the player's name to whom the prize will be awarded. See Figure 10.
26. When the PIN keypad is displayed, an attendant must enter one of the four, pre-programmed attendant PINs. See Figure 11.
27. The player then enters their PIN to confirm the awarding of the prize.
28. The attendant must then touch the **PRIZE AWARDED** button to register the payout.

NOTE: TOUCHING EXIT, WITHOUT TOUCHING PRIZE AWARDED, WILL CAUSE THE PRIZE AWARD SEQUENCE TO BE ABORTED. THE SEQUENCE WILL HAVE TO BE REPEATED TO AWARD THE PRIZE.

Pay Without PIN

If players forget their PIN number, please contact TournaCHAMP Central Administration at 020 8594 1234 for instructions.



FIGURE 9 - TOURNACHAMP MAIN MENU SCREEN

To Enter This Screen, Touch the "TournaCHAMP" Button on the Player Menu Screen, Then Touch "RANKINGS."



FIGURE 10 - RANKING SCREEN

To Enter This Screen, Touch the Player's Name on the RANKINGS Screen.



FIGURE 11 - ATTENDANT PIN SCREEN

TournaCHAMP Service

Tip #1: Use the 6 Star PIN to cut down service calls. Set up your TournaCHAMP games to use the 6 Star PIN so locations can do an Update From Server. If you notice from your operator interface connection report that a machine has not connected recently, simply call the location and have them perform an Update From Server.

To enable 6 Star:

1. Press the **SETUP** button (located on the monitor control board).
2. Touch the **System** button on the Main Menu. See Figure 1.
3. Touch the **Options** button on the System Menu. See Figure 2.
4. Touch the box next to **Enable 6 Star** to make the check appear in the box. Touch the box next to **Access TournaCHAMP Update from 6 Star** to make the check appear in the box.
5. Touch the < button once to return to the System Menu.
6. Touch the **Set 6 Star PIN** button.
7. Enter a 1-6 digit PIN number.
8. Touch **X** and touch **YES** to return to the Main Game Menu Screen.

The operator can now access the 6 Star functions by following these steps:

9. Touch the **OPTIONS** button on the Main Game Menu Screen (see Figure 3).
10. Touch the **6 Star** button.
11. Enter the 6 Star PIN.

Tip #2: Turn the game off and on once in a while, especially if the location keeps the game on 24 hours a day. This will force the modem to do a manual reinitialization and help ensure smooth connections. This can easily be done with a phone call to the location.

To Enter This Screen, Touch the "SETUP" Button



FIGURE 12- MAIN MENU SCREEN

To Enter This Screen, Touch the "System" Button at the MAIN MENU SCREEN



FIGURE 13 - SYSTEM MENU SCREEN

To Enter This Screen, Touch the "X" Button to Exit the SETUP Screens

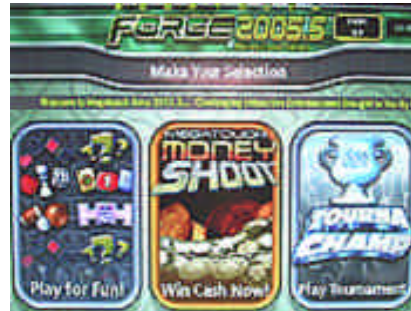

FIGURE 14 - PLAYER MENU SCREEN

TOURNACHAMP TROUBLESHOOTING GUIDE

Dial-Up Connection Status Messages

Message	Corrective Action
BAD SERVER ADDRESS	<ul style="list-style-type: none"> • The server IP address was entered incorrectly. • Verify proper entry of server IP address
CONNECTION TO ISP INTERRUPTED	<ul style="list-style-type: none"> • The connection to the ISP was broken. • Try again.
ERROR DIALING MODEM	<ul style="list-style-type: none"> • An error occurred while dialing. • Verify proper modem installation and try again.
EXPIRED VERSION OF COMMUNICATION SOFTWARE	<ul style="list-style-type: none"> • The server can't communicate with the machine. • Contact an authorized distributor for an upgrade.
INVALID INFORMATION RECEIVED FROM TOURNACHAMP SERVER	<ul style="list-style-type: none"> • Invalid information was received from the server. • Please contact the server manager with connection details.
INVALID SECURITY KEY DETECTED	<ul style="list-style-type: none"> • The security key installed in the machine does not match with previous connections to the server. • Contact the manager for more details.
ISP NOT ANSWERING CALL	<ul style="list-style-type: none"> • The call was not answered. • Make sure the ISP telephone number was entered correctly and try again.
ISP NOT RESPONDING	<ul style="list-style-type: none"> • The call was answered, but not by a detectable modem. • Make sure the ISP telephone number was entered correctly.
ISP NOT RESPONDING PROPERLY TO REQUESTS	<ul style="list-style-type: none"> • Automatic configuration requests to the ISP were not answered properly or slowly. • Try again.
ISP PHONE LINE IS BUSY	<ul style="list-style-type: none"> • The modem detected a busy signal connecting to the ISP. • Try again later.
UNABLE TO ESTABLISH CONNECTION WITH ISP	<ul style="list-style-type: none"> • The call was answered by a modem but requests for connection were not answered. • Try again. If a connection is not made after multiple attempts, the selected ISP may not conform to Internet standards.

TROUBLESHOOTING GUIDE Continued

Message	Corrective Action
SECURITY KEY VIOLATION	<ul style="list-style-type: none"> • The security key installed in the machine does not match with previous connections to the server. • Contact TournaCHAMP Central for more details.
SERVER ERROR REPORTED	<ul style="list-style-type: none"> • An unexpected error occurred on the server. • Please contact TournaCHAMP Central with connection details.
UNABLE TO DETECT TOURNACHAMP SERVER/SERVER NOT RESPONDING	<ul style="list-style-type: none"> • The computer at the server IP address entered in the Dial-Up Network Screen is not responding. • Verify correct server IP entry.
LOGIN INFORMATION NOT ACCEPTED BY ISP	<ul style="list-style-type: none"> • The ISP rejected either the user name or password. • Verify that the user name and password were entered correctly and the account is active.
MACHINE SERIAL NUMBER NOT VALID/NOT FOUND	<ul style="list-style-type: none"> • The serial number entered on the machine is not valid to participate in a Tournament. • Verify the serial number entered matches the serial number on the side of the machine and then contact the server manager for proper registration information.
MODEM LOST PHONE CONNECTION	<ul style="list-style-type: none"> • The connection to the ISP was interrupted. Verify telephone connection is of good quality. • Try again.
NO ANSWER	<ul style="list-style-type: none"> • The call was not answered. • Make sure the ISP telephone number was entered correctly.
NO DIAL TONE	<ul style="list-style-type: none"> • The modem did not detect a dial tone on the line. • Make sure the telephone cable is properly connected. • If your telephone system does not support dial tones, select NO in the WAIT FOR TONE section of the Dial-In Setup Screen.
NO MODEM DETECTED, CHECK MODEM INSTALLATION	<ul style="list-style-type: none"> • Could not detect proper installation of modem. • Make sure modem is installed and CMOS settings are correct.

Merit Video Machine Limited Warranty

Merit Industries, Inc. warrants its video machines to be free from defects in material and workmanship for a period of one year from the date of purchase. The warranty covers all electrical components (except fuses and light bulbs) and printed circuit boards. The touchscreen is under warranty for a period of 3 years.

Failure due to misuse, vandalism, excessive or intentional abuse, operation outside specified conditions (including, but not limited to, improper electrical power source), fire, water damage, acts of God, acts of war and civil unrest are specifically excluded.

Merit products are carefully inspected and thoroughly tested prior to packing and shipment. Any damage discovered upon receipt of goods, whether obvious or concealed, must be reported immediately to the delivering carrier and claims made directly to them. Merit assumes no responsibility for damages once the product has left its facilities and any disputes regarding transportation damage must be resolved with the shipping company(s).

Merit will repair or replace, at its option, any component, part or assembly that fails under warranty, provided that the failed item is returned, shipping charges prepaid, to Merit's repair facility and Merit is notified of the failure within the warranty period. Merit reserves the right to request the serial numbers of the item and/or game which has failed, and copies of sales invoices, bills of lading or other documents as required to determine the validity of the warranty coverage. Merit will return or replace warranty items, as specified above, shipping charges prepaid, by ground transportation.

Merit's obligation shall be limited to repair or replacement as stated above, and shall specifically exclude any liability for consequential damages or loss of earnings.

Merit may, at its discretion, provide replacement parts under warranty prior to receiving defective items, without incurring any ongoing obligation to extend such accommodations.

In certain instances, due to geographical or other considerations, Merit may offer PCB warranty service on an extended time basis as follows:

- (a) User notifies Merit in writing (or FAX) of PCB failure, providing dates of failure, serial numbers and a brief description of failure symptoms.
- (b) Failed PCBs are accumulated for a time period or quantity accumulation, as designated by Merit and sent in one shipment to save shipping expenses.
- (c) Merit honors warranty as per dates of failure notification.

The above terms and conditions constitute the sole obligation, written or implied, of Merit Industries under its warranty coverage.

Merit Industries, Inc. Software License Agreement

Merit Industries, Inc. ("Licensor") is willing to license the enclosed software to you only if you accept all of the terms in this license agreement ("Agreement").

Ownership of the Software

1. The enclosed Merit® product, which may include but is not limited to the Megatouch® software program ("Software") and the accompanying written materials are owned by Licensor and are protected by United States copyright laws, patent laws and other intellectual property laws, by laws of other nations, and by international treaties.

Restrictions on Use and Transfer

2. If this Software package contains multiple media types (such as CD's, flash cards, hard drives, etc), then you may use only the type of media appropriate for your Machine. You may not use the other media types on another Machine, or transfer, or assign them to another user except as part of the permanent transfer of the Software and all written materials (as provided for below in paragraph 4).
3. You may make one copy of the software for backup purposes only. You may not copy or make backup copies of any software security key or software security device under any circumstances.
4. You may permanently transfer the right to use the Software and accompanying written materials (including the most recent update and all prior versions) if you retain no copies and the transferee agrees in writing to be bound by the terms of this Agreement. Such a transfer of this license to another party immediately terminates your license. You may not otherwise transfer or assign the right to use the Software, except as stated in this paragraph.
5. You may not operate or allow the operation of the Software at locations where the operation of such Software does not comply with all local, state, and other governmental body laws and regulations. You agree to not use or permit the use of the Software in violation of any U.S. Federal, state, or local laws or regulations or any foreign law or regulation, including laws regarding gaming, gambling or intellectual property rights in or concerning the Software.
6. You may not modify, adapt, translate, reverse engineer, decompile, disassemble the Software or create derivative works from the Software or any component thereof; nor may you remove, modify or hide or otherwise make unreadable or non-viewable any notice, legend, advice, watermark or other designation contained on the Software, component thereof, or output therefrom.
7. You agree that the Software and the authorship, systems, ideas, inventions methods of operation, documentation and other information contained therein, and all versions, modifications and adaptations thereto are proprietary intellectual properties of Licensor and are protected by civil and criminal law, and by copyright, trade secret, trademark and the patent laws of the United States and other countries.

Limited Warranty

8. Licensor warrants, solely for your benefit, that the Software will function in material conformity, with its accompanying documentation for a period outlined in Licensor's standard product warranty period after your receipt of the Software.

Licensor's Obligations Under Warranty

9. Licensor's sole obligation under the aforesaid warranty shall be to utilize commercially reasonable efforts to correct or modify such portion of the Software as to make it materially conform with the applicable documentation.

Grant Of License

10. Licensor grants to you a limited, non-exclusive license to distribute and/or use one copy of the Software on a single Merit ("Machine") accompanied by a single licensor factory authorized security key. Licensor reserves the right to update versions of the software and the content to the Machine as deemed appropriate by the Licensor. You are entrusted to maintain and protect your single licensor factory authorized security key, password, or other identification from being utilized by any third party, and you agree to be responsible for any use of the Software provided herein by a third party utilizing your identification. Licensor maintains the right to immediately terminate your License for reasons related to misuse or other non-conformity with the rules expressed herein. While Licensor does not routinely inspect Machines, Licensor also reserves the right to inspect or audit the Software from time to time in Licensor's sole discretion. To the extent that Licensor's access to the Software requires that Licensor also gain access to a Machine in which the Software is installed, you agree to promptly provide Licensor, when requested, with permission and aid in Licensor gaining access to the Machine.

Disclaimers

11. EXCEPT AS PROVIDED IN THE SECTION ENTITLED "LIMITED WARRANTY", LICENSOR MAKES NO OTHER PROMISES, REPRESENTATIONS OR WARRANTIES, WHETHER EXPRESSED OR IMPLIED, REGARDING OR RELATING TO THE SOFTWARE OR CONTENT THEREIN OR TO ANY OTHER MATERIAL FURNISHED OR PROVIDED TO YOU PURSUANT TO THIS AGREEMENT OR OTHERWISE AND LICENSOR SPECIFICALLY DISCLAIMS ALL IMPLIED WARRANTIES OF MERCHANTABILITY AND FITNESS FOR A PARTICULAR PURPOSE WITH RESPECT TO SAID MATERIALS OR THE USE THEREOF. TO THE MAXIMUM EXTENT ALLOWABLE BY LAW THE UNIFORM COMMERCIAL CODE OR OTHER UNIFORM LAWS SHALL NOT APPLY TO THIS AGREEMENT.

Limitation on Liability

12. IN NO EVENT SHALL LICENSOR BE LIABLE UNDER ANY CLAIM, DEMAND OR ACTION ARISING OUT OF OR RELATING TO THE SOFTWARE, ITS USE, INSTALLATION OR LICENSOR'S PERFORMANCE OR LACK THEREOF UNDER THIS AGREEMENT FOR ANY SPECIAL, INDIRECT, INCIDENTAL, EXEMPLARY OR CONSEQUENTIAL DAMAGES, WHETHER OR NOT LICENSOR HAS BEEN ADVISED OF THE POSSIBILITY OF SUCH CLAIM, DEMAND OR ACTION. IN ADDITION, WITHOUT LIMITING THE FOREGOING, IN ALL EVENTS THE REMEDIES AVAILABLE TO YOU SHALL BE LIMITED TO THE AMOUNT PAID BY YOU TO LICENSOR FOR THE SOFTWARE.
13. IN NO EVENT WILL LICENSOR BE LIABLE TO YOU FOR DAMAGES, INCLUDING ANY LOSS OF PROFITS, LOST SAVINGS, OR OTHER INCIDENTAL OR CONSEQUENTIAL DAMAGES ARISING OUT OF YOUR USE, MISUSE, BREACH OF THIS AGREEMENT OR INABILITY TO USE THE SOFTWARE.

General

14. The validity and construction of this Agreement and of the rights and obligations herein shall be determined and governed by the laws of the State of New York. By accepting the terms of this Agreement, you acknowledge and accept that the courts of New York, New York shall have exclusive jurisdiction and venue regarding any disputes arising with regard to this Agreement or arising out of activity or misuse of the Software.
15. Merit, in its sole discretion, may assign this agreement or any of its rights and obligations hereunder.
16. If you have any questions concerning this Agreement or wish to contact Licensor for any reason, please write: Merit Industries, Inc., 2525 State Road, Bensalem, PA 19020, USA.

Contrat de licence de logiciel de Merit Industries, Inc.

Merit Industries, Inc. (ci-après le "Concédant") est disposé à vous accorder la licence d'utilisation du logiciel ci-inclus, à condition que vous vous engagiez à respecter tous les termes, clauses et conditions du présent contrat de licence (Contrat).

Droit de Propriété

1. Le produit Merit ci-joint contenant, mais ne s'y limitant pas, le logiciel Megatouch™ (ci-après le "logiciel") et toute la documentation écrite, restent la propriété du Concédant et sont protégés par : les lois de droits d'auteur des Etats-Unis, les lois s'appliquant aux brevets déposés et à la propriété intellectuelle, ainsi que par celles des autres pays et les traités internationaux.

Restriction d'Utilisation et Transfert

2. Si le présent logiciel comprend plusieurs types de composants (tels que CD-ROM, cartes flash, disques durs, etc), vous ne pouvez utiliser que ceux qui conviennent à votre appareil. Il est strictement interdit de les utiliser sur un autre appareil, les transférer -ou les céder à un autre utilisateur, sauf en cas de transfert permanent du logiciel et de toute la documentation écrite (comme indiqué ci-dessous au paragraphe 4).
3. Il est interdit de copier le logiciel, à l'exception d'une copie de sauvegarde. Il est aussi interdit de reproduire -ou faire des copies de sauvegarde des programmes de clé de sécurité ou autres fichiers de sécurité, quelles que soient les circonstances.
4. Vous pouvez céder en permanence à un tiers -le droit d'utiliser le LOGICIEL et toute la documentation écrite l'accompagnant, (ainsi que la plus récente mise à jour et toutes autres anciennes versions) seulement si vous n'en gardez aucune copie, et si le cessionnaire s'engage, par écrit, à respecter les termes, clauses et conditions du présent Contrat. Cette cession à un tiers met fin à votre licence immédiatement. Autrement, vous n'avez pas la permission de transférer ou d'accorder à un tiers le droit d'utiliser le présent logiciel, excepté que tel que décrit dans le présent paragraphe.
5. Il est interdit d'utiliser le présent logiciel ou de permettre son utilisation dans des emplacements où l'utilisation du présent logiciel n'est pas conforme aux lois et réglementations locales, nationales ou réglementations d'autres organismes gouvernementaux. Vous acceptez de ne pas utiliser ou d'autoriser l'utilisation du logiciel d'une manière enfreignant les lois ou réglementations s'appliquant à la propriété intellectuelle et au jeu, en vigueur aux Etats-Unis ou dans les autres pays du monde, y compris les lois de l'ensemble du logiciel.
6. Il est interdit de modifier, adapter, traduire, démonter, décompiler, désassembler le logiciel ou créer du matériel dérivé du logiciel ou de tout composant de celui-ci ; vous ne pouvez pas enlever, modifier ou cacher ou rendre illisible ou non-visible toute instruction, légende, information ou filigrane ou autre désignation qui apparaît dans le logiciel, composant dudit logiciel ou résultant dudit logiciel.
7. Vous convenez que le logiciel et les droits d'auteur, les systèmes, les idées, les inventions, les méthodes d'utilisation, la documentation et autre information incluse, ainsi que toutes les versions, modifications et adaptations qui s'y rattachent sont les propriétés intellectuelles du Concédant et sont protégées par le droit civil et pénal et par le droit d'auteur, le secret commercial, la marque déposée et le brevet aux Etats-Unis et dans les autres pays du monde.

Limite de Garantie

8. Le Concédant garantit seulement à votre intention, que le logiciel permettra une utilisation conforme, avec la documentation l'accompagnant, pendant la période de temps indiquée dans la période de garantie du produit standard du Concédant, à compter de la date de livraison du logiciel.

Responsabilité du Concédant aux termes de la Garantie

9. La seule obligation du Concédant aux termes de la garantie susmentionnée sera de faire tous les efforts commercialement raisonnables pour corriger ou modifier la partie du logiciel pour le rendre matériellement conforme aux spécifications de la documentation.

Concession de Licence

10. Le Concédant vous accorde le droit d'utiliser une seule copie par appareil Merit (ci-après "Appareil") accompagné d'une seule clé de sécurité autorisée en usine et fournie par le Concédant. Le Concédant se réserve le droit de mise à jour des versions du logiciel et du contenu de l'Appareil, quand il juge nécessaire de le faire. Il vous appartient également d'empêcher que les mots de passe ou autres codes et la clé de sécurité soient utilisés par un tiers. Vous acceptez d'assumer la responsabilité dans le cas de l'utilisation du logiciel par un tiers. Le Concédant se réserve le droit de résilier votre contrat de licence à tout moment dans l'éventualité d'une utilisation non-conforme aux clauses stipulées. Bien que le Concédant ne contrôle pas les appareils périodiquement, il se réserve toutefois le droit de contrôler le logiciel à tout moment et sans préavis de sa part. De surcroît, dans l'éventualité où le logiciel n'est accessible qu'à travers la machine dans laquelle il est installé, le licencié s'engage à donner libre accès au Concédant, ou ses représentants, à la machine et dans les plus brefs délais.

Exclusion de toute autre garantie

11. EXCEPTÉ COMME PRÉVU DANS LA SECTION INTITULÉE "LIMITE DE GARANTIE", LE CONCEDANT N'ASSURE AUCUNE AUTRE GARANTIE DE QUELQUE NATURE ET A QUELQUE TITRE QUE CE SOIT, EXPLICITE OU IMPLICITE, EN RAPPORT AVEC LE LOGICIEL ET LES COMPOSANTS QUI L'ACCOMPAGNENT OU, LE CAS ÉCHEANT, TOUT SUPPORT OU MATÉRIEL FOURNI CONFORMEMENT AU PRÉSENT CONTRAT EN PARTICULIER, LE CONCEDANT NE PEUT DONNER AUCUNE GARANTIE, DE QUELQUE NATURE QUE CE SOIT, POUR LA COMMERCIALISATION DE TOUTS LES PRODUITS EN RAPPORT AVEC LE LOGICIEL OU AVEC L'UTILISATION DE CELUI-CI. DANS LA MESURE OU CELA EST PERMIS PAR LA LOI, LE CODE UNIFORME COMMERCIAL OU AUTRE LOI UNIFORME NE S'APPLIQUE PAS AU PRÉSENT CONTRAT.

Limite de Responsabilité

12. LE CONCEDANT NE SERA EN AUCUN CAS RESPONSABLE DE TOUTE RECLAMATION, DEMANDE OU ACTION RESULTANT DE OU EN RAPPORT AVEC LE LOGICIEL, SON UTILISATION OU SON INSTALLATION, OU LA PERFORMANCE OU MANQUE DE PERFORMANCE DU CONCEDANT EN VERTU DU PRÉSENT CONTRAT POUR TOUTS DOMMAGES D'UNE NATURE QUI N'EST PAS PRÉSUMÉE PAR LA LOI ET QUI DOIVENT ÊTRE EXPRESSEMENT PROUVÉS, DOMMAGE INDIRECTS, DOMMAGES-INTÉRÊTS POUR PRÉJUDICE MORAL, QUE LE CONCEDANT AIT ÉTÉ AVISÉ OU NON DE LA POSSIBILITÉ D'UNE TELLE RECLAMATION, DEMANDE OU ACTION. DE PLUS, SANS LIMITER CE QUI PRÉCÈDE, LES DÉDOMMAGEMENTS À VOTRE DISPOSITION SERONT LIMITÉS AU MONTANT QUE VOUS AUREZ PAYÉ AU CONCEDANT POUR LE LOGICIEL.
13. LE CONCEDANT NE SERA EN AUCUN CAS RESPONSABLE : D'UNE RUPTURE DE CONTRAT, DES DOMMAGES, Y COMPRIS TOUTE PERTE DE PROFIT, PERTES D'ÉCONOMIE OU TOUTS AUTRES DOMMAGES INDIRECTS OU DOMMAGES-INTÉRÊTS ACCESSOIRES DÉCOULANT DE LA MAUVAISE UTILISATION OU DE L'IMPOSSIBILITÉ D'UTILISATION DU LOGICIEL.

Dispositions Générales

14. La validité et la construction du présent Contrat et les droits et obligations ci-inclus seront déterminés et régis par les lois de l'état de New York aux États-Unis. En acceptant les dispositions du présent contrat, vous acceptez également que tous litiges ou revendications relatives seront réglés par voie d'arbitrage par un tribunal de l'état de New York, aux États-Unis.
15. Merit Industries se réserve le droit de transférer le présent Contrat à un tiers ainsi que ses droits et obligations ci-après.
16. Pour toutes questions concernant le présent Contrat -ou si vous désirez contacter le Concédant pour une raison quelconque, veuillez écrire à : Merit Industries, Inc., 2525 State Road, Bensalem, PA 19020, États-Unis.

Merit Industries, Inc. Softwarelizenzabkommen

Merit Industries, Inc. („Lizenzgeber“) ist nur dann bereit Ihnen eine Lizenz für die beiliegende Software zu erteilen, wenn Sie alle Bestimmungen dieses Lizenzabkommens („Abkommen“) akzeptieren.

Eigentumsvorbehalt der Software

1. Das beiliegende Merit®-Produkt, welches das Megatouch® Softwareprogramm („Software“) beinhalten kann, aber nicht darauf beschränkt ist, und die schriftlichen Unterlagen sind Eigentum des Lizenzgebers und sind durch die Gesetze der Vereinigten Staaten und anderer Länder und durch internationale Verträge urheberrechtlich geschützt.

Beschränkungen im Gebrauch und Transfer

2. Sollte diese Softwarelieferung mehrere Medien enthalten (z.B. CD, Karten, Festplatten usw.), dürfen Sie nur die für Ihre Maschine angebrachte Medienart verwenden. Die anderen Medienarten dürfen nicht auf anderen Maschinen verwendet werden oder an Dritte übergeben werden, abgesehen von einem endgültigen Transfer der Software und aller schriftlichen Unterlagen (wie im untenstehenden Paragraphen 4 beschrieben).
3. Sie dürfen nur eine Sicherungskopie der Software herstellen. Unter keinen Umständen dürfen Sie einen Softwaresicherungsschlüssel oder Sicherungsmaßnahmen kopieren oder davon Sicherungskopien herstellen.
4. Sie dürfen das Nutzungsrecht für die Software und die schriftlichen Unterlagen (einschließlich der aktuellen Version und aller vorhergehenden Versionen) an Dritte übertragen, wenn Sie keine Kopie behalten und wenn der Empfänger die Bestimmungen dieses Abkommens in schriftlicher Form akzeptiert. Bei einem solchen Transfer der Lizenz an Dritte erlischt Ihre Lizenz umgehend. Abgesehen von den Bestimmungen dieses Paragraphen sind alle anderen Transfers oder Übertragungen der Nutzungsrechte für diese Software unerlaubt.
5. Sie dürfen die Software nicht benutzen oder eine Nutzung gestatten, wenn eine solche Nutzung der Software irgendwelche Gesetze und Verordnungen der kommunalen oder staatlichen Behörden verletzen würde. Sie verpflichten sich die Software nicht so zu nutzen oder nutzen zu lassen, dass sie damit gegen staatliche, Bundes- oder Lokalgesetze oder Bestimmungen der USA oder gegen ausländische Gesetze oder Bestimmungen, einschliesslich aller Gesetze bezüglich Glücksspiels, Spielens oder geistigen Eigentumsrechts der Software, verstossen.
6. Es ist Ihnen nicht gestattet, die Software abzuändern, zu verändern, zu übersetzen, rückumzuwandeln, zu dekompileieren oder zu zerlegen, oder aus der Software oder eines Teils davon andere Werke abzuleiten. Sie dürfen auch aus der Software, einem Bestandteil der Software oder aus den Datenausgaben der Software keine Hinweise, Bemerkungen, Ratschläge, Wasserzeichen oder andere Markierungen entfernen, verändern, verbergen oder auf andere Art unlesbar machen.
7. Sie akzeptieren, dass die Software und die Urheberschaft, die Systeme, die Ideen, Erfindungen, die Arbeitsweisen, die Dokumentation und alle anderen darin enthaltenen Informationen und alle Versionen, Veränderungen, und Bearbeitungen davon das geistige Eigentum des Lizenzgebers sind, und dass sie durch Straf- und Zivilgesetzgebung und durch die Copyright-, Geschäftsgeheimnis-, Warenzeichen- und die Patentgesetze der Vereinigten Staaten und anderer Länder geschützt sind.

Beschränkte Garantie

8. Der Lizenzgeber garantiert zu Ihren Gunsten, dass die Software für die angegebene normale Garantiezeit des Lizenzgebers nach Ihrer Annahme der Software in erheblicher Übereinstimmung mit der beiliegenden Dokumentation laufen wird.

Verpflichtung des Lizenzgebers im Rahmen der Garantie

9. Die ausschließliche Pflicht des Lizenzgebers im Rahmen der vorstehenden Garantie besteht darin, alle geschäftlich vertretbaren Schritte zu unternehmen, um Teile der Software zu berichtigen oder abzuändern, bis sie mit der beiliegenden Dokumentation erheblich übereinstimmen.

Übertragung der Lizenz

10. Der Lizenzgeber gewährt Ihnen eine beschränkte, nicht-ausschliessbare Lizenz zur Vertreibung und/oder Benutzung einer Kopie der Software auf einem einzelnen Merit™ („Gerät“) mit einem einzelnen werksmäßig gestatteten Sicherheitsschlüssel. Der Lizenzgeber behält sich das Recht vor, nach eigenem Ermessen die Software und den Inhalt der Maschine zu verbessern. Sie sind dafür verantwortlich ihren individuellen, vom Lizenzgeber werksmäßig gestatteten Sicherheitsschlüssel, ihr Passwort oder anderweitigen Identifikationsmechanismus instandzuhalten und abzusichern gegen die Nutzung durch eine dritte Partei, und sie akzeptieren die Verantwortung für jegliche Nutzung der besagten Software durch eine dritte Partei mithilfe ihres Identifikationsmechanismus. Obwohl der Lizenzgeber nicht regelmässig Maschinen inspiziert, behält sich der Lizenzgeber das Recht vor, ihre Lizenz umgehend zu kündigen aus Gründen des Missbrauchs oder bei Nichtbefolgung der Bestimmungen in diesem Vertrag. Der Lizenzgeber behält sich ebenfalls das Recht vor, die Software von Zeit zu Zeit nach eigenem Ermessen zu inspizieren oder zu überprüfen. Im Falle, dass der Lizenzgeber Zugang zu dem Gerät wünscht, in dem besagte Software installiert ist, erklären Sie sich bereit, dass sie dem Lizenzgeber, wenn nötig, Erlaubnis und Hilfe beim Zugang zum Gerät verschaffen.

Beschränkungen

11. ABGESEHEN VON DEN BESTIMMUNGEN DES PARAGRAPHEN „BESCHRÄNKTE GARANTIE“ GIBT DER LIZENZGEBER KEINE SONSTIGEN VERSPRECHEN, VERPFLICHTUNGEN ODER GARANTIEEN, OB AUSDRÜCKLICH ODER STILLSCHWEIGEND, FÜR DIE SOFTWARE ODER IHRE BESTANDTEILE ODER FÜR ALLE ANDEREN MATERIALIEN, DIE IHNEN IM RAHMEN DIESES ABKOMMENS ZUR VERFÜGUNG GESTELLT ODER ÜBERLASSEN WERDEN, UND DER LIZENZGEBER LEHNT AUSDRÜCKLICH ALLE ANSPRÜCHE AUF MARKTFÄHIGKEIT UND EIGNUNG DER BESAGTEN MATERIALIEN FÜR DEN GEWÖHNLICHEN GEBRAUCH AB. SOWEIT GESETZESMÄSSIG ZUGELASSEN, SOLLEN DIE HANDELSRECHTLICHE GESETZGEBUNG AUS DEM UNIFORM COMMERCIAL CODE ODER ANDERE GESETZE AUF DIESES ABKOMMEN NICHT ANWENDBAR SEIN.

Haftungsbeschränkung

12. DER LIZENZGEBER HAT KEINERLEI HAFTUNG BEI EINEM ANSPRUCH, EINER FORDERUNG ODER EINER KLAGE, DIE AUF NUTZUNG DER SOFTWARE, DEREN INSTALLIERUNG, DER LEISTUNG DES LIZENZGEBERS ODER DESSEN VERSAGEN IM RAHMEN DIESES ABKOMMENS FÜR JEGLICHE FOLGE-, INDIREKTE, SONDER- ODER NEBENSCHÄDEN BERUHEN, SELBST WENN DER LIZENZGEBER AUF DIE MÖGLICHKEIT EINES SOLCHEN ANSPRUCHES, EINER FORDERUNG ODER EINER KLAGE HINGEWIESEN WURDE. WEITERHIN UND OHNE BESCHRÄNKUNG DES LETZTEN SATZES, DÜRFEN IN ALLEN FÄLLEN DIE IHNEN ZUR VERFÜGUNG STEHENDEN ABHILFEN DIE VON IHNEN FÜR DIE SOFTWARE AN DEN LIZENZGEBER GEZAHLTE SUMME NICHT ÜBERSCHREITEN.
13. DER LIZENZGEBER HAT IN KEINEM FALL EINE HAFTUNG IHNEN GEGENÜBER FÜR SCHÄDEN, EINSCHLIESSLICH ETWAIGER GEWINNVERLUSTE, NICHT REALISierter EINSPARUNGEN ODER ANDERER NEBEN- ODER FOLGESCHÄDEN, DIE AUS IHRER VERWENDUNG, MISSBRAUCH, VERLETZUNG DIESES ABKOMMENS ODER GEBRAUCHSUNFÄHIGKEIT DER SOFTWARE ENTSTEHEN.

Allgemein

14. Die Rechtsgültigkeit und Provisionen dieses Abkommens und der darin enthaltenen Rechte und Pflichten werden durch die Gesetze des Staates von New York bestimmt. Sollten sie diese Vereinbarungen annehmen, dann akzeptieren Sie, dass der ausschliessliche Erfüllungsort und Gerichtsstand bei den Gerichten von New York im Staat New York liegen hinsichtlich aller Streitigkeiten, die diesen Vertrag betreffen, oder die durch Leistung oder Missbrauch der besagten Software entstehen.
15. Merit kann nach eigenem Ermessen dieses Abkommen oder jedes der darin enthaltenen Rechte und Pflichten an Dritte abtreten.
16. Bei Rückfragen über dieses Abkommen oder wenn Sie den Lizenzgeber aus einem anderen Grund kontaktieren wollen, bitte schreiben an: Merit Industries, Inc., 2525 State Road, Bensalem, PA 19020, USA.

Please read the enclosed license agreement. Operation of this game constitutes acceptance of the Merit Software License Agreement.

Veillez lire le contrat de licence d'utilisation ci-inclus. Si vous utilisez ce jeu, vous vous engagez à respecter les termes et conditions du contrat de licence d'utilisation du logiciel de Merit.

Bitte beiliegendes Lizenzabkommen durchlesen. Das Merit Software Lizenzabkommen tritt in Kraft, sobald dieses Spiel verwendet wird.